

1994

---

**UNIFORM  
BUILDING  
CODE™**

**VOLUME 2**

**STRUCTURAL ENGINEERING DESIGN PROVISIONS**



*Fourth Printing*

Publication Date: May 1, 1994

ISSN 0896-9655

COPYRIGHT © 1991, 1992, 1993, 1994

by

**International Conference of Building Officials**

5360 WORKMAN MILL ROAD  
WHITTIER, CALIFORNIA 90601-2298  
(310) 699-0541

PRINTED IN THE U.S.A.

---

# Preface

The *Uniform Building Code* is dedicated to the development of better building construction and greater safety to the public by uniformity in building laws. The code is founded on broad-based principles that make possible the use of new materials and new construction systems.

The *Uniform Building Code* was first enacted by the International Conference of Building Officials at the Sixth Annual Business Meeting held in Phoenix, Arizona, October 18-21, 1927. Revised editions of this code have been published since that time at approximate three-year intervals. New editions incorporate changes approved since the last edition.

The *Uniform Building Code* is designed to be compatible with related publications to provide a complete set of documents for regulatory use. See the publications list following this preface for a listing of the complete family of Uniform Codes and related publications.

**Code Changes.** Anyone may propose amendments to this code. For more information, write to the International Conference of Building Officials, 5360 Workman Mill Road, Whittier, California 90601-2298. Changes to the code are processed each year and published as supplements in a form allowing ready adoption by local communities. These changes are carefully reviewed in public hearings by experts in the field of building construction and fire and life safety. An analysis of changes between editions is published in the *Analysis of Revisions to the Uniform Codes*.

**Marginal Markings.** Solid vertical lines in the margins within the body of the code indicate a change from the requirements of the 1991 edition except where an entire chapter was revised, a new chapter was added or a change was minor. Where an entire chapter was revised or a new chapter was added, a notation appears at the beginning of that chapter. The letter **F** repeating in line vertically in the margin indicates that the provision is maintained under the code change procedures of the International Fire Code Institute. Deletion indicators (◆) are provided in the margin where a paragraph or item listing has been deleted if the deletion resulted in a change of requirements.

**Common Code Format.** The provisions of the 1994 edition of the *Uniform Building Code* have been reformatted into the common code format established by the Council of American Building Officials. The new format establishes a common format of chapter designations for the three model building codes published in the United States. Apart from those changes approved by the conference membership, this reformatting has not changed the technical content of the code.

The chart on the page following this preface indicates how the new chapters are grouped, lists the new chapter designations and indicates the general location of the provisions from the 1991 edition. Cross-reference tables are available to assist in locating provisions of the 1991 edition in the 1994 edition.

**Three-Volume Set.** Provisions of the *Uniform Building Code* and the *U.B.C. Standards* have been divided into a three-volume set. Volume 1 accommodates administrative, fire- and life-safety and field inspection provisions. Chapters 1 through 15 and Chapters 24 through 35 are printed in Volume 1 in their entirety. Any appendix chapters associated with these chapters are printed in their entirety at the end of Volume 1. Excerpts of certain chapters from Volume 2 are reprinted in Volume 1 to provide greater usability.

Volume 2 accommodates structural engineering design provisions, and specifically contains Chapters 16 through 23 printed in their entirety. Included in this volume are design standards previously published in the *U.B.C. Standards*. Design standards have been added to their respective chapters as divisions of the chapters. Any appendix chapters associated with these chapters are printed in their entirety at the end of Volume 2. Excerpts of certain chapters from Volume 1 are reprinted in Volume 2 to provide greater usability.

Volume 3 contains material, testing and installation standards.

**Metrication.** The *Uniform Building Code* has been metricated for the 1994 edition. The metric conversions are provided in parenthesis following the English units. Where industry has made metric conversions available, the conversions conform to current industry standards.

Formulas are also provided with metric equivalents. Metric equivalent formulas immediately follow the English formula and are denoted by "For SI:" preceding the metric equivalent. Some formulas do not use dimensions and, thus, are not provided with a metric equivalent. Multiplying conversion factors have been provided for formulas where metric forms were unavailable. Tables are provided with multiplying conversion factors in subheadings for each tabulated unit of measurement. Metricated tables of the Uniform Codes are available from the Conference.

1994 U.B.C. Chapter	1991 U.B.C. Chapter
<b>ADMINISTRATION AND TERMS</b>	
1 Administration	1, 2, 3
2 Definitions and Abbreviations	4
<b>BUILDING PLANNING</b>	
3 Use or Occupancy	5-12
4 Special Use and Occupancy	18, 39, 40, 48, 56 and part of 6, 7, 9, 17, 19
5 General Building Limitations	Part of 5 and Section 1717
6 Types of Construction	19, 20, 21, 22, part of 17 and 18
<b>FIRE PROTECTION</b>	
7 Fire-resistant Materials and Construction	43 and part of 17-19 and 25
8 Interior Finishes	Part of 5 and 42
9 Fire-protection Systems	38, 57 and part of 32
<b>OCCUPANT NEEDS</b>	
10 Means of Egress	33 and part of 17
11 Accessibility	31
12 Interior Environment	Part of 5 and 12
<b>BUILDING ENVELOPE</b>	
13 Energy Conservation	Section 1715
14 Exterior Wall Coverings	30 and part of 17
15 Roofs and Roof Structures	32, 36 and Section 1719
<b>STRUCTURAL SYSTEMS</b>	
16 Structural Forces	23
17 Structural Tests and Inspections	50 and part of 3, 17 and 30
18 Foundations and Retaining Walls	29
<b>STRUCTURAL MATERIALS</b>	
19 Concrete	26
20 Lightweight Metals	28
21 Masonry	24
22 Steel	27
23 Wood	25
<b>NONSTRUCTURAL MATERIALS</b>	
24 Glass and Glazing	34, 54
25 Gypsum Board and Plaster	47
26 Plastic	52, part of 17 and Section 3007

1994 U.B.C. Chapter	1991 U.B.C. Chapter
<b>BUILDING SERVICES</b>	
27 Electrical Systems	New
28 Mechanical Systems	New
29 Plumbing Systems	New and part of 5-12
30 Elevators, Dumbwaiters, Escalators and Moving Walks	51
<b>SPECIAL DEVICES AND CONDITIONS</b>	
31 Special Construction	37 and part of 5
32 Construction in the Public Right of Way	45
33 Site Work, Demolition and Construction	44 and part of 25 and 29
34 Existing Structures	part of 2 and 5
<b>STANDARDS</b>	
35 Uniform Building Code Standards	60
<b>APPENDIX CHAPTERS</b>	
A3 Detention and Correction Facilities; Agricultural Buildings; Group R, Division 3; and Group R, Division 4 Requirements	10; 11; and 12, Div. I and II
A4 Barriers for Swimming Pools, Spas and Hot Tubs; Aviation Control Towers; and Fallout Shelters	7; 12, Div. III; 57
A9 Basement Pipe Inlets	38
A11 Site Accessibility; and Accessibility for Existing Buildings	31
A12 Ventilation; and Sound Transmission Control	5, 35
A13 Energy Conservation in New Building Construction	53
A15 Reroofing	32
A16 Snow Load Design; Earthquake Recording Instrumentation; and Seismic-isolated Structures	23; Div. I, II, III
A18 Waterproofing and Dampproofing Foundations	29
A19 Protection of Residential Concrete Exposed to Freezing and Thawing	26
A21 Prescriptive Masonry Construction in High-wind Areas	24
A23 Conventional Light-frame Construction in High-wind Areas	25
A29 Minimum Plumbing Fixtures	New
A30 Elevators, Dumbwaiters, Escalators and Moving Walks	51
A31 Flood-resistant Construction; Membrane Structures; and Patio Covers	23, Div. IV; 49; 55
A33 Excavation and Grading	70
A34 Life-safety Requirements for Existing Buildings Other Than High-rise Buildings; and for Existing High-rise Buildings	1

# CODES AND RELATED PUBLICATIONS

The International Conference of Building Officials (ICBO) publishes the family of Uniform Codes, each correlated with the *Uniform Building Code*<sup>™</sup> to provide jurisdictions with a complete set of building-related regulations for adoption. Other reference materials and related codes are available to improve knowledge of code enforcement and administration of building inspection programs. Publications are continually being added, so inquiries should be directed to Conference headquarters for a listing of available products. The following publications are available from ICBO:

## UNIFORM CODES

**Uniform Building Code**, Volumes 1, 2 and 3. The most widely adopted model building code in the United States, the performance-based *Uniform Building Code* is a proven document, meeting the needs of government units charged with the enforcement of building regulations. Volume 1 contains administrative, fire- and life-safety and field inspection provisions; Volume 2 contains structural engineering design provisions; and Volume 3 contains material, testing and installation standards.

**Uniform Mechanical Code**<sup>™</sup>. Provides a complete set of requirements for the design, construction, installation and maintenance of heating, ventilating, cooling and refrigeration systems; incinerators and other heat-producing appliances.

**Uniform Fire Code**<sup>™</sup>, Volumes 1 and 2. The premier model fire code in the United States, the *Uniform Fire Code* sets forth provisions necessary for fire prevention and fire protection. Published by the International Fire Code Institute, the *Uniform Fire Code* is endorsed by the Western Fire Chiefs Association, the International Association of Fire Chiefs and ICBO. Volume 1 contains code provisions compatible with the *Uniform Building Code*, and Volume 2 contains standards referenced from the code provisions.

**Uniform Housing Code**<sup>™</sup>. Provides complete requirements affecting conservation and rehabilitation of housing. Its regulations are compatible with the *Uniform Building Code*.

**Uniform Code for the Abatement of Dangerous Buildings**<sup>™</sup>. A code compatible with the *Uniform Building Code* and the *Uniform Housing Code* which provides equitable remedies consistent with other laws for the repair, vacation or demolition of dangerous buildings.

**Uniform Sign Code**<sup>™</sup>. Dedicated to the development of better sign regulation, its requirements pertain to all signs and sign construction attached to buildings.

**Uniform Administrative Code**<sup>™</sup>. This code covers administrative areas in connection with adoption of the *Uniform Building Code*, *Uniform Mechanical Code* and related codes. It contains provisions which relate to site preparation, construction, alteration, moving, repair and use and occupancies of buildings or structures and building service equipment, including plumbing, electrical and mechanical regulations. The code is compatible with the administrative provisions of all codes published by the Conference.

**Uniform Building Security Code**<sup>™</sup>. This code establishes minimum standards to make dwelling units resistant to unlawful entry. It regulates swinging doors, sliding doors, windows and hardware in connection with dwelling units of apartment houses or one- and two-family dwellings. The code gives consideration to the concerns of police, fire and building officials in establishing requirements for resistance to burglary which are compatible with fire and life safety.

**Uniform Code for Building Conservation**<sup>™</sup>. A building conservation guideline presented in code format which will provide a community with the means to preserve its existing buildings while achieving appropriate levels of safety. It is formatted in the same manner as the *Uniform Building Code*, is compatible with other Uniform Codes, and may be adopted as a code or used as a guideline.

**Uniform Zoning Code**<sup>™</sup>. This newest addition to the Uniform Codes family is dedicated to intelligent community development and to the benefit of the public welfare by providing a means of promoting uniformity in zoning laws and enforcement.

**Dwelling Construction under the Uniform Building Code**<sup>™</sup>. Designed primarily for use in home building and apprentice training, this book contains requirements applicable to the construction of one- and two-story dwellings based on the requirements of the *Uniform Building Code*. Available in English or Spanish.

**Dwelling Construction under the Uniform Mechanical Code**<sup>™</sup>. This publication is for the convenience of the homeowner or contractor interested in installing mechanical equipment in a one- or two-family dwelling in conformance with the *Uniform Mechanical Code*.

**Quick-Reference Guide to the Occupancy Requirements of the 1994 U.B.C.** Code requirements are compiled in this publication by occupancy groups for quick access. These tabulations assemble requirements for each occupancy classification in the code. Provisions, such as fire-resistive ratings for occupancy separations in Table 3-B, exterior

wall and opening protection requirements in Table 5-A-1, and fire-resistive ratings for types of construction in Table 6-A, are tabulated for quick reference and comparison.

**Supplements to U.B.C. and related codes.** Published each of the two years between editions, the Supplements contain all changes approved during that year, plus an analysis of those changes.

**Metricated Tables and Figures of the 1994 Uniform Codes.** The tables presented in the 1994 Uniform Codes tabulate values in inch-pound units system and are provided with multiplying factors to convert values to the SI equivalent. This publication provides all the tables and figures of the Uniform Codes completely metricated. All tabulated values will be presented in SI units without reference to the inch-pound equivalent.

**Uniform Building Code—1927 Edition.** A special 60th anniversary printing of the first published *Uniform Building Code*.

## **CABO CODES**

**CABO One and Two Family Dwelling Code.** Jointly sponsored by ICBO and the other model building code organizations, this code eliminates conflicts and duplications among the model codes to achieve national uniformity. Covers mechanical and plumbing requirements as well as construction and occupancy.

**Application and Commentary on CABO One and Two Family Dwelling Code.** An interpretative commentary on the *CABO One and Two Family Dwelling Code* intended to enhance uniformity of interpretation and application of the code nationwide. Developed by the three model code organizations, this document includes numerous illustrations of code requirements and the rationale for individual provisions.

**CABO Model Energy Code.** This code includes minimum requirements for effective use of energy in the design of new buildings and structures and additions to existing buildings. It is based on American Society of Heating, Refrigeration and Air-conditioning Engineers Standard 90A-1980 and was originally developed jointly by ICBO, BOCA, SBCCI and the National Conference of States on Building Codes and Standards under a contract funded by the United States Department of Energy. The code is now maintained by CABO and is adopted by reference in the *Uniform Building Code*.

## **TECHNICAL REFERENCES AND EDUCATIONAL MATERIALS**

**Analysis of Revisions to the Uniform Codes™.** An analysis of changes between the previous and new editions of the Uniform Codes is provided. Changes between code editions are noted either at the beginning of chapters or in the margins of the code text.

**1991/1994 Cross-Reference Directory to the U.B.C. and U.M.C.** Both the U.B.C. and U.M.C. have been reformatted and reorganized for the 1994 editions. This publication provides two directories for both the U.B.C. and U.M.C. to cross-reference the provisions from the 1991 format to the 1994 format. The first cross-reference for each code lists the 1991 section numbers and indicates where provisions from the 1991 U.B.C. and U.M.C. are located in the 1994 editions. Other cross-reference tables list the 1994 U.B.C. and U.M.C. section numbers and refer to their origin in the 1991 codes.

**Handbook to the Uniform Building Code.** The handbook is a completely detailed and illustrated commentary on the *Uniform Building Code*, tracing historical background and rationale of the codes through the current edition. Also included are numerous drawings and figures clarifying the application and intent of the code provisions. Also available in electronic format.

**Handbook to the Uniform Mechanical Code.** An indispensable tool for understanding the provisions of the current U.M.C., the handbook traces the historical background and rationale behind the U.M.C. provisions, includes 160 figures which clarify the intent and application of the code, and provides a chapter-by-chapter analysis of the U.M.C.

**Uniform Building Code Application/Interpretation Manual.** This manual discusses sections of the *Uniform Building Code* with a question-and-answer format, providing a comprehensive analysis of the intent of the code sections. Most sections include illustrative examples. The manual is in loose-leaf format so that code interpretations published in *Building Standards* magazine may be inserted. Also available in electronic format.

**Uniform Mechanical Code Application/Interpretation Manual.** As a companion document to the *Uniform Mechanical Code*, this manual provides a comprehensive analysis of the intent of a number of code sections in an easy-to-use question-and-answer format. The manual is available in a loose-leaf format and includes illustrative examples for many code sections.

**Plan Review Manual.** A practical text that will assist and guide both the field inspector and plan reviewer in applying the code requirements. This manual covers the nonstructural and basic structural aspects of plan review.

**Field Inspection Manual.** An important fundamental text for courses of study at the community college and trade or technical school level. It is an effective text for those studying building construction or architecture and includes sample forms and checklists for use in the field.

**Building Department Administration.** An excellent guide for improvement of skills in departmental management and in the enforcement and application of the Building Code and other regulations administered by a building inspection department. This textbook will also be a valuable aid to instructors, students and those in related professional fields.

**Building Department Guide to Disaster Mitigation.** This new, expanded guide is designed to assist building departments in developing or updating disaster mitigation plans. Subjects covered include guidelines for damage mitigation, disaster-response management, immediate response, mutual aid and inspections, working with the media, repair and recovery policies, and public information bulletins. This publication is a must for those involved in preparing for and responding to disaster.

**Building Official Management Manual.** This manual addresses the unique nature of code administration and the managerial duties of the building official. A supplementary insert addresses the budgetary and financial aspects of a building department. It is also an ideal resource for those preparing for the management module of the CABO Building Official Certification Examination.

**Legal Aspects of Code Administration.** A manual developed by the three model code organizations to inform the building official on the legal aspects of the profession. The text is written in a logical sequence with explanation of legal terminology. It is designed to serve as a refresher for those preparing to take the legal module of the CABO Building Official Certification Examination.

**U.M.C. Workbook.** Designed for independent study or use with instructor-led programs based on the *Uniform Mechanical Code*, this comprehensive study guide consists of 16 learning sessions, with the first two sessions reviewing the purpose, scope, definitions and administrative provisions and the remaining 14 sessions progressively exploring the requirements for installing, inspecting and maintaining heating, ventilating, cooling and refrigeration systems.

**Concrete Manual.** A publication for individuals seeking an understanding of the fundamentals of concrete field technology and inspection practices. Of particular interest to concrete construction inspectors, it will also benefit employees of concrete producers, contractors, testing and inspection laboratories and material suppliers.

**Reinforced Concrete Masonry Construction Inspector's Handbook.** A comprehensive information source written especially for masonry inspection covering terminology, technology, materials, quality control, inspection and standards. Published jointly by ICBO and the Masonry Institute of America.

**You Can Build It!** Sponsored by ICBO in cooperation with CABO, this booklet contains information and advice to aid "do-it-yourselfers" with building projects. Provides guidance in necessary procedures such as permit requirements, codes, plans, cost estimation, etc.

**Guidelines for Manufactured Housing Installations.** A guideline in code form, implementing the *Uniform Building Code* and its companion code documents to regulate the permanent installation of a manufactured home on a privately owned, nonrental site. A commentary is included to explain specific provisions, and codes applying to each component part are defined.

**Accessibility Reference Guide.** This guide will be a valuable resource for architects, interior designers, plan reviewers and others who design and enforce accessibility provisions. Features include accessibility requirements, along with detailed commentary and graphics to clarify the provisions; cross-references to other applicable sections of the U.B.C. and the Americans with Disabilities Act Accessibility Guidelines; a checklist of U.B.C. provisions on access and usability requirements; and many other useful references.

**U.B.C. Field Inspection Workbook.** A comprehensive workbook for studying the provisions of the U.B.C. Divided into 12 sessions, this workbook focuses on the U.B.C. combustible construction requirements for the inspection of wood-framed construction.

**Educational and Technical Reference Materials.** The Conference has been a leader in the development of texts and course material to assist in the educational process. These materials include vital information necessary for the building official and subordinates in carrying out their responsibilities and have proven to be excellent references in connection with community college curricula and higher-level courses in the field of building construction technology and inspection and in the administration of building departments. A full line of videotapes and automated products are also available.

## Volume 2

Chapters 1 through 15 are printed in Volume 1 of the *Uniform Building Code*.

### Chapter 16 STRUCTURAL FORCES

#### Division I—GENERAL DESIGN REQUIREMENTS

##### SECTION 1601 — SCOPE

This chapter prescribes general design requirements applicable to all structures regulated by this code.

##### SECTION 1602 — DEFINITIONS

The following definitions give the meaning of certain terms used in this chapter:

**DEAD LOAD** is the vertical load due to the weight of all permanent structural and nonstructural components of a building, such as walls, floors, roofs and fixed service equipment.

**LIVE LOAD** is the load superimposed by the use and occupancy of the building not including the wind load, earthquake load or dead load.

**LOAD DURATION** is the period of continuous application of a given load, or the aggregate of periods of intermittent application of the same load.

##### SECTION 1603 — DESIGN METHODS

**1603.1 General.** Buildings and other structures, and all portions thereof, shall be designed and constructed to sustain, within the limitations specified in this code, all dead loads and all other loads specified within this chapter, elsewhere in this code. Impact loads shall be considered in the design of any structure where impact loads occur.

**EXCEPTION:** Unless otherwise required by the building official, buildings or portions thereof which are constructed in accordance with the conventional framing requirements specified in Chapter 23 of this code shall be deemed to meet the requirements of this section.

**1603.2 Standards.** The standards listed below are recognized standards. (See Section 3503.)

1. Wind design.
  - 1.1 ASCE 7, Chapter 6, Minimum Design Loads for Buildings and Other Structures
  - 1.2 ANSI EIA/TIA 222-E, Structural Standards for Steel Antenna Towers and Antenna Supporting Structures
  - 1.3 ANSI/NAAMM FP1001, Guide Specifications for the Design Loads of Metal Flagpoles

**1603.3 Rationality.**

**1603.3.1 General.** Any system or method of construction to be used shall be based on a rational analysis in accordance with well-established principles of mechanics. Such analysis shall result in a system which provides a complete load path capable of transferring all loads and forces from their point of origin to the load-resisting elements. The analysis shall include, but not be limited to, the provisions of Sections 1603.3.2 through 1603.5.

**1603.3.2 Distribution of horizontal shear.** The total lateral force shall be distributed to the various vertical elements of the lateral-force-resisting system in proportion to their rigidities consider-

ing the rigidity of the horizontal bracing system or diaphragm. Rigid elements that are assumed not to be part of the lateral-force-resisting system may be incorporated into buildings, provided that their effect on the action of the system is considered and provided for in the design.

**1603.3.3 Horizontal torsional moments.** Provision shall be made for the increased forces induced on resisting elements of the structural system resulting from torsion due to eccentricity between the center of application of the lateral forces and the center of rigidity of the lateral force-resisting system. Forces shall not be decreased due to torsional effects. For accidental torsion requirements for seismic design, see Section 1628.6.

**1603.3.4 Stability against overturning.** Every building or structure shall be designed to resist the overturning effects caused by the lateral forces specified in this chapter. See Section 1619 for wind and Section 1628 for seismic.

**1603.3.5 Anchorage.** Anchorage of the roof to walls and columns, and of walls and columns to foundations, shall be provided to resist the uplift and sliding forces which result from the application of the prescribed forces. For additional requirements for masonry or concrete walls, see Section 1611.

**1603.4 Critical Distribution of Live Loads.** Where structural members are arranged so as to create continuity, the loading conditions which would cause maximum shear and bending moments along the member shall be investigated.

**1603.5 Stress Increases.** All allowable stresses and soil-bearing values specified in this code for working stress design may be increased one third when considering wind or earthquake forces either acting alone or when combined with vertical loads. No increase will be allowed for vertical loads acting alone.

**1603.6 Load Factors and Load Combinations.** When the design of a building, structure or portion thereof is based on ultimate strength design (concrete), plastic design (steel) or load and resistance factor design (steel), each component shall be designed to resist the most critical effects of the load factors and load combinations in the appropriate material chapter or U.B.C. standard. When the design of a building, structure or portion thereof is based on allowable stress or working stress design, each component shall be designed to resist the most critical effect resulting from the following combination of loads. (Floor live load shall not be included when its inclusion results in lower stresses in the member under investigation.)<sup>1</sup>

1. Dead plus floor live plus roof live (or snow).<sup>2</sup>
2. Dead plus floor live plus wind<sup>2</sup> (or seismic).
3. Dead plus floor live plus wind plus snow/2.<sup>2</sup>
4. Dead plus floor live plus snow plus wind/2.<sup>2</sup>
5. Dead plus floor live plus snow<sup>3</sup> plus seismic.

## SECTION 1604 — FLOOR DESIGN

**1604.1 General.** Floors shall be designed for the unit loads set forth in Table 16-A. These loads shall be taken as the minimum live loads in pounds per square foot of horizontal projection to be

<sup>1</sup>Lateral earth pressure shall be included in the design when it will result in a more critical combination.

<sup>2</sup>Crane hook loads need not be combined with roof live load or with more than three fourths of the snow load or one half of the wind load.

<sup>3</sup>Design snow loads of 30 pounds per square foot (psf) (1.44 kN/m<sup>2</sup>) or less need not be combined with seismic loads. Where design snow loads exceed 30 psf (1.44 kN/m<sup>2</sup>) the design snow load shall be included with seismic loads, but may be reduced up to 75 percent where consideration of siting, configuration and load duration warrant when approved by the building official.

used in the design of buildings for the occupancies listed, and loads at least equal shall be assumed for uses not listed in this section but which create or accommodate similar loadings.

When it can be determined in designing floors that the actual live load will be greater than the value shown in Table 16-A, the actual live load shall be used in the design of such buildings or part thereof and special provisions shall be made for machine or apparatus loads.

**1604.2 Distribution of Uniform Floor Loads.** Where uniform floor loads are involved, consideration may be limited to full dead load on all spans in combination with full live load on adjacent spans and on alternate spans.

**1604.3 Concentrated Loads.** Provision shall be made in designing floors for a concentrated load as set forth in Table 16-A placed upon any space  $2\frac{1}{2}$  feet (762 mm) square, wherever this load upon an otherwise unloaded floor would produce stresses greater than those caused by the uniform load required therefor.

Provision shall be made in areas where vehicles are used or stored for concentrated loads consisting of two or more loads spaced 5 feet (1524 mm) nominally on center without uniform live loads. Each load shall be 40 percent of the gross weight of the maximum-size vehicle to be accommodated. The condition of concentrated or uniform live load producing the greater stresses shall govern. Parking garages for the storage of private or pleasure-type motor vehicles with no repair or refueling shall have a floor system designed for a concentrated load of not less than 2,000 pounds (8.9 kN) acting on an area of 20 square inches (12 900 mm<sup>2</sup>) without uniform live loads. The condition of concentrated or uniform live load producing the greater stresses shall govern.

Provision shall be made for special vertical and lateral loads as set forth in Table 16-B.

**1604.4 Partition Loads.** Floors in office buildings and in other buildings where partition locations are subject to change shall be designed to support, in addition to all other loads, a uniformly distributed dead load equal to 20 pounds per square foot (0.96 kN/m<sup>2</sup>). Access floor systems may be designed to support, in addition to all other loads, a uniformly distributed dead load equal to 10 pounds per square foot (0.48 kN/m<sup>2</sup>).

**1604.5 Live Loads Posted.** The live loads for which each floor or part thereof of a commercial or industrial building is or has been designed shall have such designed live loads conspicuously posted by the owner in that part of each story in which they apply, using durable metal signs, and it shall be unlawful to remove or deface such notices. The occupant of the building shall be responsible for keeping the actual load below the allowable limits.

## SECTION 1605 — ROOF DESIGN

**1605.1 General.** Roofs shall sustain, within the stress limitations of this code, all dead loads plus unit live loads as set forth in Table 16-C. The live loads shall be assumed to act vertically upon the area projected upon a horizontal plane.

**1605.2 Distribution of Loads.** Where uniform roof loads are involved in the design of structural members arranged so as to create continuity, consideration may be limited to full dead loads on all spans in combination with full live loads on adjacent spans and on alternate spans.

**EXCEPTION:** Alternate span loading need not be considered where the uniform roof live load is 20 pounds per square foot (0.96 kN/m<sup>2</sup>) or more or the provisions of Section 1605.4 are met.

For those conditions where light-gage metal preformed structural sheets serve as the support and finish of roofs, roof structural members arranged so as to create continuity shall be considered adequate if designed for full dead loads on all spans in combination with the most critical one of the following superimposed loads:

1. Snow load in accordance with Section 1605.4.
2. The uniform live load set forth in Table 16-C on all spans.

3. A concentrated gravity load of 2,000 pounds (8.9 kN) placed on any span supporting a tributary area greater than 200 square feet (18.58 m<sup>2</sup>) so as to create maximum stress in the member whenever this loading creates greater stresses than those caused by the uniform live load. The concentrated load shall be placed on the member over a length of 2<sup>1</sup>/<sub>2</sub> feet (762 mm) along the span. The 2,000-pound (8.9 kN) load need not be applied to more than one span simultaneously.

4. Water accumulation as prescribed in Section 1605.6.

**1605.3 Unbalanced Loading.** Unbalanced loads shall be used where such loading will result in larger members or connections. Trusses and arches shall be designed to resist the stresses caused by unit live loads on one half of the span if such loading results in reverse stresses, or stresses greater in any portion than the stresses produced by the required unit live load upon the entire span. For roofs whose structures are composed of a stressed shell, framed or solid, wherein stresses caused by any point loading are distributed throughout the area of the shell, the requirements for unbalanced unit live load design may be reduced 50 percent.

**1605.4 Snow Loads.** Snow loads full or unbalanced shall be considered in place of loads set forth in Table 16-C, where such loading will result in larger members or connections.

Potential unbalanced accumulation of snow at valleys, parapets, roof structures and offsets in roofs of uneven configuration shall be considered. Where snow loads occur, the snow loads shall be determined by the building official.

Snow loads in excess of 20 pounds per square foot (0.96 kN/m<sup>2</sup>) may be reduced for each degree of pitch over 20 degrees by  $R_s$  as determined by the following formula:

$$R_s = \frac{S}{40} - \frac{1}{2} \quad (5-1)$$

For SI: 
$$R_s = \frac{S}{40} - 0.024$$

**WHERE:**

$R_s$  = snow load reduction in pounds per square foot (kN/m<sup>2</sup>) per degree of pitch over 20 degrees.

$S$  = total snow load in pounds per square foot (kN/m<sup>2</sup>).

For alternate design procedure see Appendix Chapter 16, Division I.

**1605.5 Special Roof Loadings.** Roofs to be used for special purposes shall be designed for appropriate loads as approved by the building official.

Greenhouse roof bars, purlins and rafters shall be designed to carry a 100-pound-minimum (444.8 N) concentrated load in addition to the live load.

**1605.6 Water Accumulation.** All roofs shall be designed with sufficient slope or camber to assure adequate drainage after the long-time deflection from dead load or shall be designed to support maximum loads, including possible ponding of water from any source, including snow, due to deflection. See Section 1608 for deflection criteria.

**SECTION 1606 — REDUCTION OF LIVE LOADS**

The design live load determined using the unit live loads as set forth in Table 16-A for floors and Table 16-C, Method 2, for roofs may be reduced on any member supporting more than 150 square feet (13.94 m<sup>2</sup>), including flat slabs, except for floors in places of public assembly and for live loads greater than 100 pounds per square foot (4.79 kN/m<sup>2</sup>), in accordance with the following formula:

$$R = r(A - 150) \quad (6-1)$$

$$\text{For SI:} \quad R = r(A - 13.94) \left( \frac{1}{0.0929} \right)$$

The reduction shall not exceed 40 percent for members receiving load from one level only, 60 percent for other members, or  $R$  as determined by the following formula:

$$R = 23.1 (1 + D/L) \quad (6-2)$$

**WHERE:**

- $A$  = area of floor or roof supported by the member, square feet ( $m^2$ ).
- $D$  = dead load per square foot ( $m^2$ ) of area supported by the member.
- $L$  = unit live load per square foot ( $m^2$ ) of area supported by the member.
- $R$  = reduction in percentage.
- $r$  = rate of reduction equal to 0.08 percent for floors. See Table 16-C for roofs.

For storage live loads exceeding 100 pounds per square foot ( $4.79 \text{ kN}/m^2$ ), no reduction shall be made, except that design live loads on columns may be reduced 20 percent.

The live load reduction shall not exceed 40 percent in garages for the storage of private pleasure cars having a capacity of not more than nine passengers per vehicle.

**SECTION 1607 — ALTERNATE FLOOR LIVE LOAD REDUCTION**

As an alternate to Formula (6-1), the unit live loads set forth in Table 16-A may be reduced in accordance with Formula (7-1) on any member, including flat slabs, having an influence area of 400 square feet ( $37.16 \text{ m}^2$ ) or more.

$$L = L_o \left( 0.25 + \frac{15}{\sqrt{A_I}} \right) \quad (7-1)$$

$$\text{For SI:} \quad L = L_o \left( 0.25 + \frac{4.57}{\sqrt{A_I}} \right)$$

**WHERE:**

- $A_I$  = influence area, in square feet (square meters). The influence area  $A_I$  is four times the tributary area for a column, two times the tributary area for a beam, equal to the panel area for a two-way slab, and equal to the product of the span and the full flange width for a precast T-beam.
- $L$  = reduced design live load per square foot of area (per square meter of area) supported by the member.
- $L_o$  = unreduced design live load per square foot of area (per square meter of area) supported by the member (Table 16-A).

The reduced live load shall not be less than 50 percent of the unit live load  $L_o$  for members receiving load from one level only, nor less than 40 percent of the unit live load  $L_o$  for other members.

**SECTION 1608 — DEFLECTION**

The deflection of any structural members shall not exceed the values set forth in Table 16-D, based on the factors set forth in Table 16-E. The deflection criteria representing the most restrictive condition shall apply. Deflection criteria for materials not specified shall be developed in a manner consistent with the provisions of this section. See Section 1605.6 for camber requirements. Span tables for light wood-frame construction as specified in Sections 2326.8 and 2326.12.2 shall conform to

the design criteria contained therein. (For concrete, see Section 1909.5.2.6; for aluminum, see Section 2003.)

## SECTION 1609 — SPECIAL DESIGN

**1609.1 General.** In addition to the design loads specified in this chapter, the design of all structures shall consider the special loads set forth in Table 16-B and in this section.

**1609.2 Retaining Walls.** Retaining walls shall be designed to resist the lateral pressure of the retained material in accordance with accepted engineering practice. Walls retaining drained earth may be designed for pressure equivalent to that exerted by a fluid weighing not less than 30 pounds per cubic foot ( $4.71 \text{ kN/m}^3$ ) and having a depth equal to that of the retained earth. Any surcharge shall be in addition to the equivalent fluid pressure.

Retaining walls shall be designed to resist sliding by at least 1.5 times the lateral force and overturning by at least 1.5 times the overturning moment.

**1609.3 Heliport and Helistop Landing Areas.** In addition to other design requirements of this chapter, heliport and helistop landing or touchdown areas shall be designed for the maximum stress induced by the following:

1. Dead load plus actual weight of the helicopter.
2. Dead load plus a single concentrated impact load covering 1 square foot ( $0.092903 \text{ m}^2$ ) of 0.75 times the fully loaded weight of the helicopter if it is equipped with hydraulic-type shock absorbers, or 1.5 times the fully loaded weight of the helicopter if it is equipped with a rigid or skid-type landing gear.
3. The dead load plus a uniform live load of 100 pounds per square foot ( $4.9 \text{ kN/m}^2$ ). The required live load may be reduced in accordance with the formula in Section 1606.

**1609.4 Hydrostatic Uplift.** All foundations, slabs and other footings subject to water pressure shall be designed to resist a uniformly distributed uplift equal to the full hydrostatic pressure.

**1609.5 Flood-resistant Construction.** For flood-resistant construction requirements see Appendix Chapter 31, Division I.

## SECTION 1610 — WALLS AND STRUCTURAL FRAMING

**1610.1 General.** Walls and structural framing shall be erected true and plumb in accordance with the design.

**1610.2 Interior Walls.** Interior walls, permanent partitions and temporary partitions which exceed 6 feet (1828 mm) in height shall be designed to resist all loads to which they are subjected but not less than a force of 5 pounds per square foot ( $0.24 \text{ kN/m}^2$ ) applied perpendicular to the walls. The deflection of such walls under a load of 5 pounds per square foot ( $0.24 \text{ kN/m}^2$ ) shall not exceed  $1/240$  of the span for walls with brittle finishes and  $1/120$  of the span for walls with flexible finishes. See Table 16-O for earthquake design requirements where such requirements are more restrictive.

**EXCEPTION:** Flexible, folding or portable partitions are not required to meet the load and deflection criteria but must be anchored to the supporting structure to meet the provisions of this code.

## SECTION 1611 — ANCHORAGE OF CONCRETE OR MASONRY WALLS

Concrete or masonry walls shall be anchored to all floors, roofs and other structural elements which provide required lateral support for the wall. Such anchorage shall provide a positive direct connection capable of resisting the horizontal forces specified in this chapter or a minimum force of 200 pounds per lineal foot ( $2.92 \text{ N/mm}$ ) of wall, whichever is greater. Walls shall be designed to resist

bending between anchors where the anchor spacing exceeds 4 feet (1220 mm). Required anchors in masonry walls of hollow units or cavity walls shall be embedded in a reinforced grouted structural element of the wall. See Sections 1630, 1631.2.8 and 1631.2.9.

### **SECTION 1612 — PREFABRICATED CONSTRUCTION**

**1612.1 Connections.** Every device used to connect prefabricated assemblies shall be designed as required by this code and be capable of developing the strength of the members connected, except in the case of members forming part of a structural frame designed as specified in this chapter. Connections shall be capable of withstanding uplift force as specified in this chapter.

**1612.2 Pipes and Conduit.** In structural design, due allowance shall be made for any material to be removed for the installation of pipes, conduits or other equipment.

**1612.3 Tests and Inspections.** See Section 1704 for requirements for tests and inspections of prefabricated construction.

## Division II—WIND DESIGN

### SECTION 1613 — GENERAL

Every building or structure and every portion thereof shall be designed and constructed to resist the wind effects determined in accordance with the requirements of this section. Wind shall be assumed to come from any horizontal direction. No reduction in wind pressure shall be taken for the shielding effect of adjacent structures.

Structures sensitive to dynamic effects, such as buildings with a height-to-width ratio greater than five, structures sensitive to wind-excited oscillations, such as vortex shedding or icing, and buildings over 400 feet (121.9 m) in height, shall be, and any structure may be, designed in accordance with approved national standards.

The provisions of this section do not apply to building and foundation systems in those areas subject to scour and water pressure by wind and wave action. Buildings and foundations subject to such loads shall be designed in accordance with approved national standards.

### SECTION 1614 — DEFINITIONS

The following definitions apply only to this part:

**BASIC WIND SPEED** is the fastest-mile wind speed associated with an annual probability of 0.02 measured at a point 33 feet (10 000 mm) above the ground for an area having exposure category C.

**EXPOSURE B** has terrain with buildings, forest or surface irregularities, covering at least 20 percent of the ground level area extending 1 mile (1.61 km) or more from the site.

**EXPOSURE C** has terrain which is flat and generally open, extending one-half mile (0.81 km) or more from the site in any full quadrant.

**EXPOSURE D** represents the most severe exposure in areas with basic wind speeds of 80 miles per hour (mph) (129 km/h) or greater and has terrain which is flat and unobstructed facing large bodies of water over one mile (1.61 km) or more in width relative to any quadrant of the building site. Exposure D extends inland from the shoreline  $\frac{1}{4}$  mile (0.40 km) or 10 times the building height, whichever is greater.

**FASTEST-MILE WIND SPEED** is the wind speed obtained from wind velocity maps prepared by the National Oceanographic and Atmospheric Administration and is the highest sustained average wind speed based on the time required for a mile-long sample of air to pass a fixed point.

**OPENINGS** are apertures or holes in the exterior wall boundary of the structure. All windows or doors or other openings shall be considered as openings unless such openings and their frames are specifically detailed and designed to resist the loads on elements and components in accordance with the provisions of this section.

**PARTIALLY ENCLOSED STRUCTURE OR STORY** is a structure or story which has more than 15 percent of any windward projected area open and in which the area of opening on all other projected areas is less than half of that on the windward projection.

**SPECIAL WIND REGION** is an area where local records and terrain features indicate 50-year fastest-mile basic wind speed is higher than shown in Figure 16-1.

**UNENCLOSED STRUCTURE OR STORY** is a structure which has 85 percent or more openings on all sides.

### SECTION 1615 — SYMBOLS AND NOTATIONS

The following symbols and notations apply to the provisions of this part.

- $C_e$  = combined height, exposure and gust factor coefficient as given in Table 16-G.  
 $C_q$  = pressure coefficient for the structure or portion of structure under consideration as given in Table 16-H.  
 $I_w$  = importance factor as set forth in Table 16-K.  
 $P$  = design wind pressure.  
 $q_s$  = wind stagnation pressure at the standard height of 33 feet (10 000 mm) as set forth in Table 16-F.

### SECTION 1616 — BASIC WIND SPEED

The minimum basic wind speed at any site shall not be less than that shown in Figure 16-1. For those areas designated in Figure 16-1 as special wind regions and other areas where local records or terrain indicate higher 50-year (mean recurrence interval) fastest-mile wind speeds, these higher values shall be the minimum basic wind speeds.

### SECTION 1617 — EXPOSURE

An exposure shall be assigned at each site for which a building or structure is to be designed.

### SECTION 1618 — DESIGN WIND PRESSURES

Design wind pressures for buildings and structures and elements therein shall be determined for any height in accordance with the following formula:

$$P = C_e C_q q_s I_w \quad (18-1)$$

### SECTION 1619 — PRIMARY FRAMES AND SYSTEMS

**1619.1 General.** The primary frames or load-resisting system of every structure shall be designed for the pressures calculated using Formula (18-1) and the pressure coefficients,  $C_q$ , of either Method 1 or Method 2. In addition, design of the overall structure and its primary load-resisting system shall conform to Section 1603.

The base overturning moment for the entire structure, or for any one of its individual primary lateral-resisting elements, shall not exceed two thirds of the dead-load-resisting moment. For an entire structure with a height-to-width ratio of 0.5 or less in the wind direction and a maximum height of 60 feet (18 290 mm), the combination of the effects of uplift and overturning may be reduced by one third. The weight of earth superimposed over footings may be used to calculate the dead-load-resisting moment.

**1619.2 Method 1 (Normal Force Method).** Method 1 shall be used for the design of gabled rigid frames and may be used for any structure. In the Normal Force Method, the wind pressures shall be assumed to act simultaneously normal to all exterior surfaces. For pressures on roofs and leeward walls,  $C_e$  shall be evaluated at the mean roof height.

**1619.3 Method 2 (Projected Area Method).** Method 2 may be used for any structure less than 200 feet (60 960 mm) in height except those using gabled rigid frames. This method may be used in stability determinations for any structure less than 200 feet (60 960 mm) high. In the Projected Area Method, horizontal pressures shall be assumed to act upon the full vertical projected area of the structure, and the vertical pressures shall be assumed to act simultaneously upon the full horizontal projected area.

### SECTION 1620 — ELEMENTS AND COMPONENTS OF STRUCTURES

Design wind pressures for each element or component of a structure shall be determined from Formula (18-1) and  $C_q$  values from Table 16-H, and shall be applied perpendicular to the surface. For

outward acting forces the value of  $C_e$  shall be obtained from Table 16-G based on the mean roof height and applied for the entire height of the structure. Each element or component shall be designed for the more severe of the following loadings:

1. The pressures determined using  $C_q$  values for elements and components acting over the entire tributary area of the element.
2. The pressures determined using  $C_q$  values for local areas at discontinuities such as corners, ridges and eaves. These local pressures shall be applied over a distance from a discontinuity of 10 feet (3048 mm) or 0.1 times the least width of the structure, whichever is less.

The wind pressures from Sections 1619 and 1620 need not be combined.

### **SECTION 1621 — OPEN-FRAME TOWERS**

Radio towers and other towers of trussed construction shall be designed and constructed to withstand wind pressures specified in this section, multiplied by the shape factors set forth in Table 16-H.

### **SECTION 1622 — MISCELLANEOUS STRUCTURES**

Greenhouses, lath houses, agricultural buildings or fences 12 feet (3658 mm) or less in height shall be designed in accordance with Division II, Chapter 16. However, three fourths of  $q_s$ , but not less than 10 pounds per square foot (0.48 kN/m<sup>2</sup>), may be substituted for  $q_s$  in Formula (18-1). Pressures on local areas at discontinuities need not be considered.

### **SECTION 1623 — OCCUPANCY CATEGORIES**

For the purpose of wind-resistant design, each structure shall be placed in one of the occupancy categories listed in Table 16-K. Table 16-K lists importance factors,  $I_w$ , for each category.

## Division III—EARTHQUAKE DESIGN

## SECTION 1624 — GENERAL

**1624.1 Minimum Seismic Design.** Structures and portions thereof shall, as a minimum, be designed and constructed to resist the effects of seismic ground motions as provided in this section.

**1624.2 Seismic and Wind.** When the code-prescribed wind design produces greater effects, the wind design shall govern, but detailing requirements and limitations prescribed in this and referenced sections shall be followed.

## SECTION 1625 — DEFINITIONS

For the purposes of this section certain terms are defined as follows:

**BASE** is the level at which the earthquake motions are considered to be imparted to the structure or the level at which the structure as a dynamic vibrator is supported.

**BASE SHEAR,  $V$** , is the total design lateral force or shear at the base of a structure.

**BEARING WALL SYSTEM** is a structural system without a complete vertical load-carrying space frame. See Section 1627.6.2.

**BOUNDARY ELEMENT** is an element at edges of openings or at perimeters of shear walls or diaphragms.

**BRACED FRAME** is an essentially vertical truss system of the concentric or eccentric type which is provided to resist lateral forces.

**BUILDING FRAME SYSTEM** is an essentially complete space frame which provides support for gravity loads. See Section 1627.6.3.

**COLLECTOR** is a member or element provided to transfer lateral forces from a portion of a structure to vertical elements of the lateral-force-resisting system.

**CONCENTRICALLY BRACED FRAME** is a braced frame in which the members are subjected primarily to axial forces.

**DIAPHRAGM** is a horizontal or nearly horizontal system acting to transmit lateral forces to the vertical resisting elements. The term "diaphragm" includes horizontal bracing systems.

**DIAPHRAGM CHORD** is the boundary element of a diaphragm or shear wall which is assumed to take axial stresses analogous to the flanges of a beam.

**DIAPHRAGM STRUT** (drag strut, tie, collector) is the element of a diaphragm parallel to the applied load which collects and transfers diaphragm shear to the vertical resisting elements or distributes loads within the diaphragm. Such members may take axial tension or compression.

**DRIFT.** See "story drift."

**DUAL SYSTEM** is a combination of moment-resisting frames and shear walls or braced frames designed in accordance with the criteria of Section 1627.6.5.

**ECCENTRICALLY BRACED FRAME (EBF)** is a steel-braced frame designed in conformance with Section 2211.10.

**ESSENTIAL FACILITIES** are those structures which are necessary for emergency operations subsequent to a natural disaster.

**FLEXIBLE ELEMENT** or system is one whose deformation under lateral load is significantly larger than adjoining parts of the system. Limiting ratios for defining specific flexible elements are set forth in Section 1628.5 or 1630.2.

**HORIZONTAL BRACING SYSTEM** is a horizontal truss system that serves the same function as a diaphragm.

**INTERMEDIATE MOMENT-RESISTING FRAME (IMRF)** is a concrete frame designed in accordance with Section 1921.8.

**LATERAL-FORCE-RESISTING SYSTEM** is that part of the structural system assigned to resist lateral forces.

**MOMENT-RESISTING FRAME** is a frame in which members and joints are capable of resisting forces primarily by flexure.

**MOMENT-RESISTING WALL FRAME (MRWF)** is a masonry wall frame especially detailed to provide ductile behavior and designed in conformance with Section 2103.2.5.

**ORDINARY BRACED FRAME (OBF)** is a steel-braced frame designed in accordance with the provisions of Section 2211.8 or 2212.6, or concrete-braced frame designed in accordance with Section 1921.

**ORDINARY MOMENT-RESISTING FRAME (OMRF)** is a moment-resisting frame not meeting special detailing requirements for ductile behavior.

**ORTHOGONAL EFFECTS** are the effects on structural elements common to the resisting systems along two orthogonal axes due to earthquake forces acting in a direction other than those axes.

**PA EFFECT** is the secondary effect on shears, axial forces and moments of frame members induced by the vertical loads acting on the laterally displaced building frame.

**SHEAR WALL** is a wall designed to resist lateral forces parallel to the plane of the wall (sometimes referred to as a vertical diaphragm).

**SOFT STORY** is one in which the lateral stiffness is less than 70 percent of the stiffness of the story above. See Table 16-L.

**SPACE FRAME** is a three-dimensional structural system, without bearing walls, composed of members interconnected so as to function as a complete self-contained unit with or without the aid of horizontal diaphragms or floor-bracing systems.

**SPECIAL CONCENTRICALLY BRACED FRAME (SCBF)** is a steel-braced frame designed in conformance with the provisions of Section 2211.9.

**SPECIAL MOMENT-RESISTING FRAME (SMRF)** is a moment-resisting frame specially detailed to provide ductile behavior and comply with the requirements given in Chapter 19 or 22.

**STORY** is the space between levels. Story  $x$  is the story below Level  $x$ .

**STORY DRIFT** is the displacement of one level relative to the level above or below.

**STORY DRIFT RATIO** is the story drift divided by the story height.

**STORY SHEAR,  $V_x$** , is the summation of design lateral forces above the story under consideration.

**STRENGTH** is the capacity of an element or a member to resist factored load as specified in Chapters 16, 19, 21 and 22.

**STRUCTURE** is an assemblage of framing members designed to support gravity loads and resist lateral forces. Structures may be categorized as building structures or nonbuilding structures.

**SUBDIAPHRAGM** is a portion of a larger wood diaphragm designed to anchor and transfer local forces to primary diaphragm struts and the main diaphragm.

**VERTICAL-LOAD-CARRYING FRAME** is a space frame designed to carry all vertical gravity loads.

**WEAK STORY** is one in which the story strength is less than 80 percent of that of the story above. See Table 16-L.

**SECTION 1626 — SYMBOLS AND NOTATIONS**

The following symbols and notations apply to the provisions of this section:

- $A_c$  = the combined effective area, in square feet ( $m^2$ ), of the shear walls in the first story of the structure.
- $A_e$  = the minimum cross-sectional shear area in any horizontal plane in the first story, in square feet ( $m^2$ ), of a shear wall.
- $A_x$  = the torsional amplification factor at Level  $x$ .
- $C$  = numerical coefficient specified in Section 1628.2.1.
- $C_p$  = numerical coefficient specified in Section 1630 and given in Table 16-O.
- $C_r$  = numerical coefficient given in Section 1628.2.2.
- $D_e$  = the length, in feet (m), of a shear wall in the first story in the direction parallel to the applied forces.
- $DL$  = dead load on a structural element.
- $E$  = load due to an earthquake on a structural element.
- $F_i, F_n, F_x$  = lateral force applied to Level  $i, n,$  or  $x,$  respectively.
- $F_p$  = lateral forces on a part of the structure.
- $F_t$  = that portion of the base shear,  $V,$  considered concentrated at the top of the structure in addition to  $F_n.$
- $f_i$  = lateral force at Level  $i$  for use in Formula (28-5).
- $g$  = acceleration due to gravity.
- $h_i, h_n, h_x$  = height in feet (m) above the base to Level  $i, n,$  or  $x,$  respectively.
- $I$  = importance factor given in Table 16-K.
- $I_p$  = importance factor specified in Section 1630.2.
- $LL$  = live load on a structural element.
- Level  $i$  = level of the structure referred to by the subscript  $i.$  “ $i = 1$ ” designates the first level above the base.
- Level  $n$  = that level which is uppermost in the main portion of the structure.
- Level  $x$  = that level which is under design consideration. “ $x = 1$ ” designates the first level above the base.
- $R_w$  = numerical coefficient given in Tables 16-N and 16-P.
- $S$  = site coefficient for soil characteristics given in Table 16-J.
- $T$  = fundamental period of vibration, in seconds, of the structure in the direction under consideration.
- $V$  = the total design lateral force or shear at the base.
- $V_x$  = the design story shear in Story  $x.$
- $W$  = the total seismic dead load defined in Section 1628.1.
- $W_p$  = the weight of an element or component.
- $w_i, w_x$  = that portion of  $W$  which is located at or is assigned to Level  $i$  or  $x,$  respectively.
- $w_{px}$  = the weight of the diaphragm and the elements tributary thereto at Level  $x,$  including applicable portions of other loads defined in Section 1628.1.
- $Z$  = seismic zone factor given in Table 16-I.
- $\delta_i$  = horizontal displacement at Level  $i$  relative to the base due to applied lateral forces,  $f,$  for use in Formula (28-5).

## SECTION 1627 — CRITERIA SELECTION

**1627.1 Basis for Design.** The procedures and limitations for the design of structures shall be determined considering zoning, site characteristics, occupancy, configuration, structural system and height in accordance with this section. The minimum design seismic forces shall be those determined in accordance with the static lateral force procedure of Section 1628 except as modified by Section 1629.5.3. One- and two-family dwellings in Seismic Zone 1 need not conform to the provisions of this section.

**1627.2 Seismic Zones.** Each site shall be assigned to a seismic zone in accordance with Figure 16-2. Each structure shall be assigned a zone factor,  $Z$ , in accordance with Table 16-I.

**1627.3 Site Geology and Soil Characteristics.** Soil profile type and site coefficient,  $S$ , shall be established in accordance with Table 16-J.

**1627.4 Occupancy Categories.** For purposes of earthquake-resistant design, each structure shall be placed in one of the occupancy categories listed in Table 16-K. Table 16-K lists importance factors,  $I$ , and review requirements for each category.

### 1627.5 Configuration Requirements.

**1627.5.1 General.** Each structure shall be designated as being structurally regular or irregular.

**1627.5.2 Regular structures.** Regular structures have no significant physical discontinuities in plan or vertical configuration or in their lateral-force-resisting systems such as the irregular features described below.

#### 1627.5.3 Irregular structures.

1. Irregular structures have significant physical discontinuities in configuration or in their lateral force-resisting systems. Irregular features include, but are not limited to, those described in Tables 16-L and 16-M. Structures in Seismic Zone 1 and in Occupancy Category 4 in Seismic Zone 2 need be evaluated only for vertical irregularities of Type 5 (Table 16-L) and horizontal irregularities of Type 1 (Table 16-M).

2. Structures having one or more of the features listed in Table 16-L shall be designated as if having a vertical irregularity.

**EXCEPTION:** Where no story drift ratio under design lateral forces is greater than 1.3 times the story drift ratio of the story above the structure may be deemed to not have the structural irregularities of Type 1 or 2 in Table 16-L. The story drift ratio for the top two stories need not be considered. The story drifts for this determination may be calculated neglecting torsional effects.

3. Structures having one or more of the features listed in Table 16-M shall be designated as having a plan irregularity.

### 1627.6 Structural Systems.

**1627.6.1 General.** Structural systems shall be classified as one of the types listed in Table 16-N and defined in this subsection.

**1627.6.2 Bearing wall system.** A structural system without a complete vertical load-carrying space frame. Bearing walls or bracing systems provide support for all or most gravity loads. Resistance to lateral load is provided by shear walls or braced frames.

**1627.6.3 Building frame system.** A structural system with an essentially complete space frame providing support for gravity loads. Resistance to lateral load is provided by shear walls or braced frames.

**1627.6.4 Moment-resisting frame system.** A structural system with an essentially complete space frame providing support for gravity loads. Moment-resisting frames provide resistance to lateral load primarily by flexural action of members.

**1627.6.5 Dual system.** A structural system with the following features:

1. An essentially complete space frame which provides support for gravity loads.
2. Resistance to lateral load is provided by shear walls or braced frames and moment-resisting frame (SMRF, IMRF or steel OMRF). The moment-resisting frames shall be designed to independently resist at least 25 percent of the design base shear.
3. The two systems shall be designed to resist the total design base shear in proportion to their relative rigidities considering the interaction of the dual system at all levels.

**1627.6.6 Undefined structural system.** A structural system not listed in Table 16-N.

**1627.6.7 Nonbuilding structural system.** A structural system conforming to Section 1632.

**1627.7 Height Limits.** Height limits for the various structural systems in Seismic Zones 3 and 4 are given in Table 16-N.

**EXCEPTION:** Regular structures may exceed these limits by not more than 50 percent for unoccupied structures which are not accessible to the general public.

**1627.8 Selection of Lateral-force Procedure.**

**1627.8.1 General.** Any structure may be, and certain structures defined below shall be, designed using the dynamic lateral-force procedures of Section 1629.

**1627.8.2 Static.** The static lateral-force procedure of Section 1628 may be used for the following structures:

1. All structures, regular or irregular, in Seismic Zone 1 and in Occupancy Category 4 in Seismic Zone 2.
2. Regular structures under 240 feet (73 152 mm) in height with lateral-force resistance provided by systems listed in Table 16-N except where Section 1627.8.3, Item 4, applies.
3. Irregular structures not more than five stories or 65 feet (19 812 mm) in height.
4. Structures having a flexible upper portion supported on a rigid lower portion where both portions of the structure considered separately can be classified as being regular, the average story stiffness of the lower portion is at least 10 times the average story stiffness of the upper portion and the period of the entire structure is not greater than 1.1 times the period of the upper portion considered as a separate structure fixed at the base.

**1627.8.3 Dynamic.** The dynamic lateral-force procedure of Section 1629 shall be used for all other structures, including the following:

1. Structures 240 feet (73 152 mm) or more in height except as permitted by Section 1627.8.2, Item 1.
2. Structures having a stiffness, weight or geometric vertical irregularity of Type 1, 2 or 3 as defined in Table 16-L or structures having irregular features not described in Table 16-L or 16-M except as permitted by Section 1628.3.2.
3. Structures over five stories or 65 feet (19 812 mm) in height in Seismic Zones 3 and 4 not having the same structural system throughout their height except as permitted by Section 1628.3.2.
4. Structures, regular or irregular, located on Soil Profile Type S4 which have a period greater than 0.7 second. The analysis shall include the effects of the soils at the site and shall conform to Section 1629.2, Item 4.

**1627.9 System Limitations.**

**1627.9.1 Discontinuity.** Structures with a discontinuity in capacity, vertical irregularity Type 5 as defined in Table 16-L, shall not be over two stories or 30 feet (9144 mm) in height where the weak story has a calculated strength of less than 65 percent of the story above.

**EXCEPTION:** Where the weak story is capable of resisting a total lateral seismic force of 3 ( $R_w/8$ ) times the design force prescribed in Section 1628.

**1627.9.2 Undefined structural systems.** Undefined structural systems shall be shown by technical and test data which establish the dynamic characteristics and demonstrate the lateral-force resistance and energy absorption capacity to be equivalent to systems listed in Table 16-N for equivalent  $R_w$  values.

**1627.9.3 Irregular features.** All structures having irregular features described in Table 16-L or 16-M shall be designed to meet the additional requirements of those sections referenced in the tables.

#### 1627.10 Alternative Procedures.

**1627.10.1 General.** Alternative lateral-force procedures using rational analyses based on well-established principles of mechanics may be used in lieu of those prescribed in these provisions.

**1627.10.2 Seismic isolation.** Seismic isolation, energy dissipation and damping systems may be used in the design of structures when approved by the building official and when special detailings are used to provide results equivalent to those obtained by the use of conventional structural systems. For alternate design procedures on seismic isolation systems, refer to Appendix Chapter 16, Division III, Earthquake Regulations for Seismic-isolated Structures.

### SECTION 1628 — MINIMUM DESIGN LATERAL FORCES AND RELATED EFFECTS

**1628.1 General.** Structures shall be designed for seismic forces coming from any horizontal direction.

The design seismic forces may be assumed to act nonconcurrently in the direction of each principal axis of the structure, except as required by Section 1631.1.

Seismic dead load,  $W$ , is the total dead load and applicable portions of other loads listed below.

1. In storage and warehouse occupancies, a minimum of 25 percent of the floor live load shall be applicable.
2. Where a partition load is used in the floor design, a load of not less than 10 pounds per square foot (psf) (0.48 kN/m<sup>2</sup>) shall be included.
3. Design snow loads of 30 pounds per square foot (psf) (1.44 kN/m<sup>2</sup>) or less need not be included. Where design snow loads exceed 30 psf (1.44 kN/m<sup>2</sup>) the design snow load shall be included, but may be reduced up to 75 percent where consideration of siting, configuration and load duration warrant when approved by the building official.
4. Total weight of permanent equipment shall be included.

#### 1628.2 Static Force Procedure.

**1628.2.1 Design base shear.** The total design base shear in a given direction shall be determined from the following formula:

$$V = \frac{ZIC}{R_w} W \quad (28-1)$$

$$C = \frac{1.25S}{T^{2/3}} \quad (28-2)$$

The value of  $C$  need not exceed 2.75 and may be used for any structure without regard to soil type or structure period.

Except for those provisions where code-prescribed forces are scaled up by 3 ( $R_w/8$ ) the minimum value of the ratio  $C/R_w$  shall be 0.075.

**1628.2.2 Structure period.** The value of  $T$  shall be determined from one of the following methods:

1. **Method A:** For all buildings, the value  $T$  may be approximated from the following formula:

$$T = C_t (h_n)^{3/4} \quad (28-3)$$

**WHERE:**

$C_t = 0.035$  (0.0853) for steel moment-resisting frames.

$C_t = 0.030$  (0.0731) for reinforced concrete moment-resisting frames and eccentrically braced frames.

$C_t = 0.020$  (0.0488) for all other buildings.

Alternatively, the value of  $C_t$  for structures with concrete or masonry shear walls may be taken as  $0.1/\sqrt{A_c}$  (For **SI**:  $0.0743/\sqrt{A_c}$  for  $A_c$  in  $m^2$ ).

The value of  $A_c$  shall be determined from the following formula:

$$A_c = \Sigma A_e [0.2 + (D_e/h_n)^2] \quad (28-4)$$

The value of  $D_e/h_n$  used in Formula (28-4) shall not exceed 0.9.

2. **Method B:** The fundamental period  $T$  may be calculated using the structural properties and deformational characteristics of the resisting elements in a properly substantiated analysis. This requirement may be satisfied by using the following formula:

$$T = 2\pi \sqrt{\left( \sum_{i=1}^n w_i \delta_i^2 \right) \div \left( g \sum_{i=1}^n f_i \delta_i \right)} \quad (28-5)$$

The values of  $f_i$  represent any lateral force distributed approximately in accordance with the principles of Formulas (28-6), (28-7) and (28-8) or any other rational distribution. The elastic deflections,  $\delta_i$ , shall be calculated using the applied lateral forces,  $f_i$ . The value of  $T$  from Method B shall not be over 30 percent greater than the value of  $T$  obtained from Method A in Seismic Zone 4 and 40 percent in Seismic Zones 1, 2 and 3.

### 1628.3 Combinations of Structural Systems.

**1628.3.1 General.** Where combinations of structural systems are incorporated into the same structure, the requirements of this subsection shall be satisfied.

**1628.3.2 Vertical combinations.** The value of  $R_w$  used in the design of any story shall be less than or equal to the value of  $R_w$  used in the given direction for the story above.

**EXCEPTION:** This requirement need not be applied to a story where the dead weight above that story is less than 10 percent of the total dead weight of the structure.

Structures may be designed using the procedures of this section under the following conditions:

1. The entire structure is designed using the lowest  $R_w$  of the lateral-force-resisting systems used, or
2. The following two-stage static analysis procedures may be used for structures conforming to Section 1627.8.2, Item 4.
  - 2.1 The flexible upper portion shall be designed as a separate structure, supported laterally by the rigid lower portion, using the appropriate value of  $R_w$ .

- 2.2 The rigid lower portion shall be designed as a separate structure using the appropriate value of  $R_w$ . The reactions from the upper portion shall be those determined from the analysis of the upper portion amplified by the ratio of the  $R_w$  of the upper portion over the  $R_w$  of the lower portion.

**1628.3.3 Combinations along different axes.** In Seismic Zones 3 and 4 where a structure has a bearing wall system in only one direction, the value of  $R_w$  used for design in the orthogonal direction shall not be greater than that used for the bearing wall system.

Any combination of bearing wall systems, building frame systems, dual systems or moment-resisting frame systems may be used to resist seismic forces in structures less than 160 feet (48 768 mm) in height. Only combinations of dual systems and special moment-resisting frames shall be used to resist seismic forces in structures exceeding 160 feet (48 768 mm) in height in Seismic Zones 3 and 4.

**1628.3.4 Combinations along the same axes.** For other than dual systems, where a combination of different structural systems is utilized to resist lateral forces in the same direction, the value of  $R_w$  used in that direction shall not be greater than the least value of any of the systems utilized in that same direction.

**1628.4 Vertical Distribution of Force.** The total force shall be distributed over the height of the structure in conformance with Formulas (28-6), (28-7) and (28-8) in the absence of a more rigorous procedure.

$$V = F_t + \sum_{i=1}^n F_i \quad (28-6)$$

The concentrated force  $F_t$ , at the top, which is in addition to  $F_n$ , shall be determined from the formula:

$$F_t = 0.07TV \quad (28-7)$$

The value of  $T$  used for the purpose of calculating  $F_t$  may be the period that corresponds with the design base shear as computed using Formula (28-1).  $F_t$  need not exceed  $0.25V$  and may be considered as zero where  $T$  is 0.7 second or less. The remaining portion of the base shear shall be distributed over the height of the structure, including Level  $n$ , according to the following formula:

$$F_x = \frac{(V - F_t) w_x h_x}{\sum_{i=1}^n w_i h_i} \quad (28-8)$$

At each level designated as  $x$ , the force  $F_x$  shall be applied over the area of the building in accordance with the mass distribution at that level. Stresses in each structural element shall be calculated as the effect of forces  $F_x$  and  $F_t$  applied at the appropriate levels above the base.

**1628.5 Horizontal Distribution of Shear.** The design story shear,  $V_x$ , in any story is the sum of the forces  $F_t$  and  $F_x$  above that story.  $V_x$  shall be distributed to the various elements of the vertical lateral-force-resisting system in proportion to their rigidities, considering the rigidity of the diaphragm. See Section 1631.2.4 for rigid elements that are not intended to be part of the lateral-force-resisting systems.

Where diaphragms are not flexible, the mass at each level shall be assumed to be displaced from the calculated center of mass in each direction a distance equal to 5 percent of the building dimension at that level perpendicular to the direction of the force under consideration. The effect of this displacement on the story shear distribution shall be considered.

Diaphragms shall be considered flexible for the purposes of distribution of story shear and torsional moment when the maximum lateral deformation of the diaphragm is more than two times the

average story drift of the associated story. This may be determined by comparing the computed midpoint in-plane deflection of the diaphragm itself under lateral load with the story drift of adjoining vertical-resisting elements under equivalent tributary lateral load.

**1628.6 Horizontal Torsional Moments.** Provisions shall be made for the increased shears resulting from horizontal torsion where diaphragms are not flexible. The most severe load combination for each element shall be considered for design.

The torsional design moment at a given story shall be the moment resulting from eccentricities between applied design lateral forces at levels above that story and the vertical resisting elements in that story plus an accidental torsion.

The accidental torsional moment shall be determined by assuming the mass is displaced as required by Section 1628.5.

Where torsional irregularity exists, as defined in Table 16-M, the effects shall be accounted for by increasing the accidental torsion at each level by an amplification factor,  $A_x$ , determined from the following formula:

$$A_x = \left[ \frac{\delta_{\max}}{1.2 \delta_{\text{avg}}} \right]^2 \quad (28-9)$$

**WHERE:**

$\delta_{\text{avg}}$  = the average of the displacements at the extreme points of the structure at Level  $x$ .

$\delta_{\text{max}}$  = the maximum displacement at Level  $x$ .

The value of  $A_x$  need not exceed 3.0.

**1628.7 Overturning.**

**1628.7.1 General.** Every structure shall be designed to resist the overturning effects caused by earthquake forces specified in Section 1628.4. At any level, the overturning moments to be resisted shall be determined using those seismic forces ( $F_t$  and  $F_x$ ) which act on levels above the level under consideration. At any level, the incremental changes of the design overturning moment shall be distributed to the various resisting elements in the manner prescribed in Section 1628.5. Overturning effects on every element shall be carried down to the foundation. See Section 1631 for combining gravity and seismic forces.

**1628.7.2 Seismic Zones 3 and 4.** In Seismic Zones 3 and 4, where a lateral load-resisting element is discontinuous, such as for vertical irregularity Type 4 in Table 16-L or plan irregularity Type 4 in Table 16-M, columns supporting such elements shall have the strength to resist the axial force resulting from the following load combinations, in addition to all other applicable load combinations:

$$1.0 DL + 0.8 LL + 3 (R_w/8)E$$

$$0.85 DL \pm 3 (R_w/8)E$$

1. The axial forces in such columns need not exceed the capacity of other elements of the structure to transfer such loads to the column.

2. Such columns shall be capable of carrying the above-described axial forces without exceeding the axial load strength of the column. For designs using working stress methods this capacity may be determined using an allowable stress increase of 1.7.

3. Such columns shall meet the following detailing or member limitations:

Chapter 19, Section 1921.4, for concrete, and Chapter 22, Section 2211.5, for steel in structures in Seismic Zones 3 and 4.

Chapter 19, Section 1921.8, for concrete and Chapter 22, Divisions I and IX, special provisions for developing plastic hinges at ultimate loading, for steel in structures in Seismic Zone 2.

**1628.7.3 At foundation.** See Section 1809.4 for overturning moments to be resisted at the foundation soil interface.

**1628.8 Story Drift Limitation.**

**1628.8.1 Defined.** Story drift is the displacement of one level relative to the level above or below due to the design lateral forces. Calculated drift shall include deflections due to translation and torsional effects.

**1628.8.2 Calculated.** Calculated story drift shall not exceed  $0.04/R_w$  or 0.005 times the story height for structures having a fundamental period of less than 0.7 second. For structures having a fundamental period of 0.7 second or greater, the calculated story drift shall not exceed  $0.03/R_w$  or 0.004 times the story height.

**EXCEPTIONS:** 1. These drift limits may be exceeded when it is demonstrated that greater drift can be tolerated by both structural elements and nonstructural elements that could affect life safety.

2. There shall be no drift limit in single-story steel-framed structures classified as Groups B, F and S Occupancies or Group H, Division 4 or 5 Occupancies. In Groups B, F and S Occupancies, the primary use shall be limited to storage, factories or workshops. Minor accessory uses shall be allowed in accordance with the provisions of Section 302. Structures on which this exception is used shall not have equipment attached to the structural frame or shall have such equipment detailed to accommodate the additional drift. Walls which are laterally supported by the steel frame shall be designed to accommodate the drift in accordance with Section 1631.2.4.

**1628.8.3 Deriving forces.** The design lateral forces used to determine the calculated drift may be derived from a value of  $C$  based on the period determined from Formula (28-5) neglecting the lower-bound ratio for  $C/R_w$  of 0.075 of Section 1628.2.1 and the limitations of Section 1628.2.2, Item 2.

**1628.9  $P\Delta$  Effects.** The resulting member forces and moments and the story drifts induced by  $P\Delta$  effects shall be considered in the evaluation of overall structural frame stability.  $P\Delta$  need not be considered when the ratio of secondary moment to primary moment does not exceed 0.10; the ratio may be evaluated for any story as the product of the total dead, floor live load and snow load, as required in Section 1603.6, above the story times the seismic drift in that story divided by the product of the seismic shear in that story times the height of that story. In Seismic Zones 3 and 4,  $P\Delta$  need not be considered where the story drift ratio does not exceed  $0.02/R_w$ .

**1628.10 Vertical Component.** The following requirements apply in Seismic Zones 3 and 4 only.

Horizontal cantilever components shall be designed for a net upward force of  $0.5 Z W_p$ .

In addition to all other applicable load combinations, horizontal prestressed components shall be designed using not more than 50 percent of the dead load for the gravity load, alone or in combination with the lateral force effects.

**SECTION 1629 — DYNAMIC LATERAL-FORCE PROCEDURES**

**1629.1 General.** Dynamic analyses procedures, when used, shall conform to the criteria established in this section. The analysis shall be based on an appropriate ground motion representation and shall be performed using accepted principles of dynamics. Structures which are designed in accordance with this section shall comply with all other applicable requirements of these provisions.

**1629.2 Ground Motion.** The ground motion representation shall, as a minimum, be one having a 10 percent probability of being exceeded in 50 years and may be one of the following:

1. The normalized response spectrum given in Figure 16-3.

2. A site-specific response spectrum based on the geologic, tectonic, seismologic and soil characteristics associated with the specific site. The spectrum shall be developed for a damping ratio of

0.05 unless a different value is shown to be consistent with the anticipated structural behavior at the intensity of shaking established for the site.

3. Ground motion time histories developed for the specific site shall be representative of actual earthquake motions. Response spectra from time histories, either individually or in combination, shall approximate the site design spectrum conforming to Section 1629.2, Item 2.

4. For structures on Soil Profile Type S4, the following requirements shall apply when required by Section 1627.8.3, Item 4:

4.1 The ground motion representation shall be developed in accordance with Items 2 and 3 above.

4.2 Possible amplification of building response due to the effects of soil-structure interaction and lengthening of building period caused by inelastic behavior shall be considered.

4.3 The base shear determined by these procedures may be reduced to a design base shear,  $V$ , by dividing by a factor not greater than the appropriate  $R_w$  factor for the structure.

5. The vertical component of ground motion may be defined by scaling corresponding horizontal accelerations by a factor of two thirds. Alternative factors may be used when substantiated by site-specific data.

**1629.3 Mathematical Model.** A mathematical model of the physical structure shall represent the spatial distribution of the mass stiffness of the structure to an extent which is adequate for the calculation of the significant features of its dynamic response. A three-dimensional model shall be used for the dynamic analysis of structures with highly irregular plan configurations such as those having a plan irregularity defined in Table 16-M and having a rigid or semirigid diaphragm.

#### **1629.4 Description of Analysis Procedures.**

**1629.4.1 Response spectrum analysis.** An elastic dynamic analysis of a structure utilizing the peak dynamic response of all modes having a significant contribution to total structural response. Peak modal responses are calculated using the ordinates of the appropriate response spectrum curve which correspond to the modal periods. Maximum modal contributions are combined in a statistical manner to obtain an approximate total structural response.

**1629.4.2 Time-history analysis.** An analysis of the dynamic response of a structure at each increment of time when the base is subjected to a specific ground motion time history.

#### **1629.5 Response Spectrum Analysis.**

**1629.5.1 Number of modes.** The requirement of Section 1629.4.1 that all significant modes be included may be satisfied by demonstrating that for the modes considered, at least 90 percent of the participating mass of the structure is included in the calculation of response for each principal horizontal direction.

**1629.5.2 Combining modes.** The peak member forces, displacements, story forces, story shears and base reactions for each mode shall be combined by recognized methods. When three-dimensional models are used for analysis, modal interaction effects shall be considered when combining modal maxima.

**1629.5.3 Scaling of results.** The base shear for a given direction determined using these procedures, when less than the values below, shall be scaled up to these values.

1. The base shear shall be increased to the following percentage of the values determined from the procedures of Section 1628:

1.1 One hundred percent for irregular buildings.

1.2 Ninety percent for regular buildings, except that the base shear shall not be less than 80 percent of that determined from Section 1628 using the period,  $T$ , calculated from Method A.

All corresponding response parameters, including deflections, member forces and moments, shall be increased proportionately.

2. The base shear for a given direction determined using these procedures need not exceed that required by Item 1 above. All corresponding response parameters may be adjusted proportionately.

**1629.5.4 Directional effects.** Directional effects for horizontal ground motion shall conform to the requirements of Section 1628.1. The effects of vertical ground motions on horizontal cantilevers and prestressed elements shall be considered in accordance with Section 1628.10. Alternately, vertical seismic response may be determined by dynamic response methods; in no case shall the response used for design be less than that obtained by the static method.

**1629.5.5 Torsion.** The analysis shall account for torsional effects, including accidental torsional effects as prescribed in Section 1628.6. Where three-dimensional models are used for analysis, effects of accidental torsion shall be accounted for by appropriate adjustments in the model such as adjustment of mass locations, or by equivalent static procedures such as provided in Section 1628.6.

**1629.5.6 Dual systems.** Where the lateral forces are resisted by a dual system as defined in Section 1627.6.5, the combined system shall be capable of resisting the base shear determined in accordance with this section. The moment-resisting frame shall conform to Section 1627.6.5, Item 2 and may be analyzed using either the procedures of Section 1628.4 or those of Section 1629.5.

**1629.6 Time-history Analysis.** Time-history analyses shall meet the requirements of Section 1627.10.

## SECTION 1630 — LATERAL FORCE ON ELEMENTS OF STRUCTURES, NONSTRUCTURAL COMPONENTS AND EQUIPMENT SUPPORTED BY STRUCTURES

**1630.1 General.** Elements of structures and their attachments, permanent nonstructural components and their attachments, and the attachments for permanent equipment supported by a structure shall be designed to resist the total design seismic forces prescribed in Section 1630.2. Attachments for floor- or roof-mounted equipment weighing less than 400 pounds (181 kg), and furniture need not be designed.

Attachments shall include anchorages and required bracing. Friction resulting from gravity loads shall not be considered to provide resistance to seismic forces.

When the structural failure of the lateral force-resisting systems of nonrigid equipment would cause a life hazard, such systems shall be designed to resist the seismic forces prescribed in Section 1630.2.

When allowable design stresses and other acceptance criteria are not contained in or referenced by this code, such criteria shall be obtained from approved national standards.

**1630.2 Design for Total Lateral Force.** The total design lateral seismic force,  $F_p$ , shall be determined from the following formula:

$$F_p = Z I_p C_p W_p \quad (30-1)$$

The values of  $Z$  and  $I_p$  shall be the values used for the structure from Tables 16-I and 16-K.

The coefficient  $C_p$  is for elements and components and for rigid and rigidly supported equipment. Rigid or rigidly supported equipment is defined as having a fundamental period less than or equal to 0.06 second. Nonrigid or flexibly supported equipment is defined as a system having a fundamental period, including the equipment, greater than 0.06 second.

The lateral forces calculated for nonrigid or flexibly supported equipment supported by a structure and located above grade shall be determined considering the dynamic properties of both the

equipment and the structure which supports it, but the value shall not be less than that listed in Table 16-O. In the absence of an analysis or empirical data, the value of  $C_p$  for nonrigid or flexibly supported equipment located above grade on a structure shall be taken as twice the value listed in Table 16-O, but need not exceed 2.0.

**EXCEPTION:** Piping, ducting and conduit systems which are constructed of ductile materials and connections may use the values of  $C_p$  from Table 16-O.

The value of  $C_p$  for elements, components and equipment laterally self-supported at or below ground level may be two thirds of the value set forth in Table 16-O. However, the design lateral forces for an element or component or piece of equipment shall not be less than would be obtained by treating the item as an independent structure and using the provisions of Section 1632.

The design lateral forces determined using Formula (30-1) shall be distributed in proportion to the mass distribution of the element or component.

Forces determined using Formula (30-1) shall be used to design members and connections which transfer these forces to the seismic-resisting systems.

For applicable forces in connectors for exterior panels and diaphragms, refer to Sections 1631.2.4 and 1631.2.9.

Forces shall be applied in the horizontal directions, which result in the most critical loadings for design.

**1630.3 Specifying Lateral Forces.** Design specifications for equipment shall either specify the design lateral forces prescribed herein or reference these provisions.

**1630.4 Relative Motion of Equipment Attachments.** For equipment in Categories 1 and 2 buildings as defined in Table 16-K, the lateral-force design shall consider the effects of relative motion of the points of attachment to the structure (drift).

**1630.5 Alternative Designs.** Where an approved national standard or approved physical test data provide a basis for the earthquake-resistant design of a particular type of equipment or other non-structural component, such a standard or data may be accepted as a basis for design of the items with the following limitations:

1. These provisions shall provide minimum values for the design of the anchorage and the members and connections which transfer the forces to the seismic-resisting system.
2. The force,  $F_p$ , and the overturning moment used in the design of the nonstructural component shall not be less than 80 percent of the values that would be obtained using these provisions.

## SECTION 1631 — DETAILED SYSTEMS DESIGN REQUIREMENTS

**1631.1 General.** All structural framing systems shall comply with the requirements of Section 1627. Only the elements of the designated seismic-force-resisting system shall be used to resist design forces. The individual components shall be designed to resist the prescribed design seismic forces acting on them. The components shall also comply with the specific requirements for the material contained in Chapters 19 through 23. In addition, such framing systems and components shall comply with the detailed system design requirements contained in Section 1631.

All building components in Seismic Zones 2, 3 and 4 shall be designed to resist the effects of the seismic forces prescribed herein and the effects of gravity loadings from dead, floor live and snow loads.

Consideration shall be given to design for uplift effects caused by seismic loads. For materials which use working stress procedures, dead loads shall be multiplied by 0.85 when used to reduce uplift.

In Seismic Zones 2, 3 and 4, provision shall be made for the effects of earthquake forces acting in a direction other than the principal axes in each of the following circumstances:

The structure has plan irregularity Type 5 as given in Table 16-M.

The structure has plan irregularity Type 1 as given in Table 16-M for both major axes.

A column of a structure forms part of two or more intersecting lateral-force-resisting systems.

**EXCEPTION:** If the axial load in the column due to seismic forces acting in either direction is less than 20 percent of the column allowable axial load.

The requirement that orthogonal effects be considered may be satisfied by designing such elements for 100 percent of the prescribed seismic forces in one direction plus 30 percent of the prescribed forces in the perpendicular direction. The combination requiring the greater component strength shall be used for design. Alternatively, the effects of the two orthogonal directions may be combined on a square root of the sum of the squares (SRSS) basis. When the SRSS method of combining directional effects is used, each term computed shall be assigned the sign that will result in the most conservative result.

### 1631.2 Structural Framing Systems.

**1631.2.1 General.** Four types of general building framing systems defined in Section 1627.6 are recognized in these provisions and shown in Table 16-N. Each type is subdivided by the types of vertical elements used to resist lateral seismic forces. Special framing requirements are given in this section and in Chapters 19 through 23.

**1631.2.2 Detailing for combinations of systems.** For components common to different structural systems, the more restrictive detailing requirements shall be used.

**1631.2.3 Connections.** Connections which resist seismic forces shall be designed and detailed on the drawings.

**1631.2.4 Deformation compatibility.** All framing elements not required by design to be part of the lateral-force-resisting system shall be investigated and shown to be adequate for vertical load-carrying capacity when displaced  $3(R_w/8)$  times the displacements resulting from the required lateral forces.  $P\Delta$  effects on such elements shall be accounted for. For designs using working stress methods, this capacity may be determined using an allowable stress increase of 1.7. The rigidity of adjoining rigid and exterior elements shall be considered as follows:

**1631.2.4.1 Adjoining rigid elements.** Moment-resistant frames may be enclosed by or adjoined by more rigid elements which would tend to prevent the frame from resisting lateral forces where it can be shown that the action or failure of the more rigid elements will not impair the vertical and lateral load-resisting ability of the frame.

**1631.2.4.2 Exterior elements.** Exterior nonbearing, nonshear wall panels or elements which are attached to or enclose the exterior shall be designed to resist the forces per Formula (30-1) and shall accommodate movements of the structure resulting from lateral forces or temperature changes. Such elements shall be supported by means of cast-in-place concrete or by mechanical connections and fasteners in accordance with the following provisions:

1. Connections and panel joints shall allow for a relative movement between stories of not less than two times story drift caused by wind,  $3(R_w/8)$  times the calculated elastic story drift caused by design seismic forces, or  $1/2$  inch (13 mm), whichever is greater.
2. Connections to permit movement in the plane of the panel for story drift shall be sliding connections using slotted or oversize holes, connections which permit movement by bending of steel, or other connections providing equivalent sliding and ductility capacity.
3. Bodies of connections shall have sufficient ductility and rotation capacity so as to preclude fracture of the concrete or brittle failures at or near welds.
4. The body of the connection shall be designed for one and one-third times the force determined by Formula (30-1).

5. All fasteners in the connecting system such as bolts, inserts, welds and dowels shall be designed for four times the forces determined by Formula (30-1).
6. Fasteners embedded in concrete shall be attached to, or hooked around, reinforcing steel or otherwise terminated so as to effectively transfer forces to the reinforcing steel.

**1631.2.5 Ties and continuity.** All parts of a structure shall be interconnected and the connections shall be capable of transmitting the seismic force induced by the parts being connected. As a minimum, any smaller portion of the building shall be tied to the remainder of the building with elements having at least a strength to resist  $Z/3$  times the weight of the smaller portion.

A positive connection for resisting a horizontal force acting parallel to the member shall be provided for each beam, girder or truss. This force shall not be less than  $Z/5$  times the dead plus live load.

**1631.2.6 Collector elements.** Collector elements shall be provided which are capable of transferring the seismic forces originating in other portions of the building to the element providing the resistance to those forces.

**1631.2.7 Concrete frames.** Concrete frames required by design to be part of the lateral-force-resisting system shall conform to the following:

1. In Seismic Zones 3 and 4 they shall be special moment-resisting frames.
2. In Seismic Zone 2 they shall, as a minimum, be intermediate moment-resisting frames.

**1631.2.8 Anchorage of concrete or masonry walls.** Concrete or masonry walls shall be anchored to all floors and roofs which provide lateral support for the wall. The anchorage shall provide a positive direct connection between the wall and floor or roof construction capable of resisting the horizontal forces specified in Section 1630 or Section 1611. Requirements for developing anchorage forces in diaphragms are given in Section 1631.2.9 below. Diaphragm deformation shall be considered in the design of the supported walls.

**1631.2.9 Diaphragms.**

1. The deflection in the plane of the diaphragm shall not exceed the permissible deflection of the attached elements. Permissible deflection shall be that deflection which will permit the attached element to maintain its structural integrity under the individual loading and continue to support the prescribed loads.
2. Floor and roof diaphragms shall be designed to resist the forces determined in accordance with the following formula:

$$F_{px} = \frac{F_x + \sum_{i=x}^n F_i}{\sum_{i=x}^n w_i} w_{px} \quad (31-1)$$

The force  $F_{px}$  determined from Formula (31-1) need not exceed  $0.75 Z I w_{px}$ , but shall not be less than  $0.35 Z I w_{px}$ .

When the diaphragm is required to transfer lateral forces from the vertical resisting elements above the diaphragm to other vertical resisting elements below the diaphragm due to offset in the placement of the elements or to changes in stiffness in the vertical elements, these forces shall be added to those determined from Formula (31-1).

3. Design forces for flexible diaphragms, and their connections providing lateral supports for walls or frames of masonry or concrete, shall be calculated using an  $R_w$  not to exceed 6.

4. Diaphragms supporting concrete or masonry walls shall have continuous ties or struts between diaphragm chords to distribute the anchorage forces specified in Section 1631.2.8. Added chords may be used to form subdiaphragms to transmit the anchorage forces to the main cross-ties.

5. Where wood diaphragms are used to laterally support concrete or masonry walls, the anchorage shall conform to Section 1631.2.8 above. In Seismic Zones 2, 3 and 4 anchorage shall not be accomplished by use of toenails or nails subject to withdrawal, nor shall wood ledgers or framing be used in cross-grain bending or cross-grain tension, and the continuous ties required by Item 4 above shall be in addition to the diaphragm sheathing.

6. Connections of diaphragms to the vertical elements and to collectors and connections of collectors to the vertical elements in structures in Seismic Zones 3 and 4, having a plan irregularity of Type 1, 2, 3 or 4 in Table 16-M, shall be designed without considering one-third increase usually permitted in allowable stresses for elements resisting earthquake forces.

7. In structures in Seismic Zones 3 and 4 having a plan irregularity of Type 2 in Table 16-M, diaphragm chords and drag members shall be designed considering independent movement of the projecting wings of the structure. Each of these diaphragm elements shall be designed for the more severe of the following two assumptions:

Motion of the projecting wings in the same direction.

Motion of the projecting wings in opposing directions.

**EXCEPTION:** This requirement may be deemed satisfied if the procedures of Section 1629 in conjunction with a three-dimensional model have been used to determine the lateral seismic forces for design.

**1631.2.10 Framing below the base.** The strength and stiffness of the framing between the base and the foundation shall not be less than that of the superstructure. The special detailing requirements of Chapters 19 and 22, as appropriate, shall apply to columns supporting discontinuous lateral force-resisting elements and to SMRF, IMRF and EBF system elements below the base which are required to transmit the forces resulting from lateral loads to the foundation.

**1631.2.11 Building separations.** All structures shall be separated from adjoining structures. Separations shall allow for  $3(R_w/8)$  times the displacement due to seismic forces. When a structure adjoins a property line not common to a public way, that structure shall also be set back from the property line by at least  $3(R_w/8)$  times the displacement of that structure.

**EXCEPTION:** Smaller separations or property line setbacks may be permitted when justified by rational analyses based on maximum expected ground motions. As a minimum, building separations or property line setbacks shall not be less than  $(R_w/8) \geq 1$  times the sum of displacements due to code-specified seismic forces.

## SECTION 1632 — NONBUILDING STRUCTURES

### 1632.1 General.

**1632.1.1 Scope.** Nonbuilding structures include all self-supporting structures other than buildings which carry gravity loads and resist the effects of earthquake. Nonbuilding structures shall be designed to resist the minimum lateral forces specified in this section. Design shall conform to the applicable provisions of other sections as modified by the provisions contained in Section 1632.

**1632.1.2 Criteria.** The minimum design lateral forces prescribed in this section are at a service level (rather than yield or ultimate level). The design of nonbuilding structures shall provide sufficient strength and ductility, consistent with the provisions specified herein for buildings, to resist the effects of seismic ground motions as represented by these design forces.

When applicable, allowable stresses and other detailed design criteria shall be obtained from other sections or their referenced standards.

When applicable design stresses and other design criteria are not contained in or referenced by this code, such criteria shall be obtained from approved national standards.

**1632.1.3 Weight  $W$ .** The weight  $W$  for nonbuilding structures shall include all dead load as defined for buildings in Section 1628.1. For purposes of calculating design seismic forces in nonbuilding structures,  $W$  shall also include all normal operating contents for items such as tanks, vessels, bins and piping.

**1632.1.4 Period.** The fundamental period of the structure shall be determined by rational methods such as by using Method B in Section 1628.2.

**1632.1.5 Drift.** The drift limitations of Section 1628.8 need not apply to nonbuilding structures. Drift limitations shall be established for structural or nonstructural elements whose failure would cause life hazards.  $P\Delta$  effects shall be considered for structures whose calculated drifts exceed the values in Section 1628.8.

**1632.1.6 Interaction effects.** In Seismic Zones 3 and 4, structures which support flexible nonstructural elements whose combined weight exceeds 25 percent of the weight of the structure shall be designed considering interaction effects between the structure and the supported elements.

**1632.2 Lateral Force.** Lateral-force procedures for nonbuilding structures with structural systems similar to buildings (those with structural systems which are listed in Table 16-N) shall be selected in accordance with the provisions of Section 1627.

**EXCEPTION:** Intermediate moment-resisting frames (IMRF) may be used in Seismic Zones 3 and 4 for nonbuilding structures in Occupancy Categories 3 and 4 if (1) the structure is less than 50 feet (15 240 mm) in height and (2) an  $R_w = 4.0$  is used for design.

**1632.3 Rigid Structures.** Rigid structures (those with period  $T$  less than 0.06 second), including their anchorages, shall be designed for the lateral force obtained from Formula (32-1).

$$V = 0.5 Z I W \quad (32-1)$$

The force  $V$  shall be distributed according to the distribution of mass and shall be assumed to act in any horizontal direction.

**1632.4 Tanks with Supported Bottoms.** Flat bottom tanks or other tanks with supported bottoms, founded at or below grade, shall be designed to resist the seismic forces calculated using the procedures in Section 1632 for rigid structures considering the entire weight of the tank and its contents. Alternatively, such tanks may be designed using one of the two procedures described below.

A response spectrum analysis, which includes consideration of the actual ground motion anticipated at the site and the inertial effects of the contained fluid.

A design basis prescribed for the particular type of tank by an approved national standard, provided that the seismic zones and occupancy categories shall be in conformance with the provisions of Sections 1627.2 and 1627.4, respectively.

**1632.5 Other Nonbuilding Structures.** Nonbuilding structures which are not covered by Sections 1632.2 and 1632.3 shall be designed to resist minimum seismic lateral forces not less than those determined in accordance with the provisions in Section 1628 with the following additions and exceptions:

1. The factor  $R_w$  shall be as given in Table 16-P. The ratio  $C/R_w$  used for design shall not be less than 0.4.

2. The vertical distribution of the lateral seismic forces in structures covered by this section may be determined by using the provisions of Section 1628.4 or by using the procedures of Section 1629.

**EXCEPTION:** For irregular structures assigned to Occupancy Categories 1 and 2 which cannot be modeled as a single mass, the procedures of Section 1629 shall be used.

3. Where an approved national standard provides a basis for the earthquake-resistant design of a particular type of nonbuilding structure covered by this Section 1632.4, such a standard may be used, subject to the limitations in this section:

The seismic zones and occupancy categories shall be in conformance with the provisions of Sections 1627.5 and 1627.4, respectively.

The values for total lateral force and total base overturning moment used in design shall not be less than 80 percent of the values that would be obtained using these provisions.

**SECTION 1633 — EARTHQUAKE-RECORDING INSTRUMENTATIONS**

For earthquake-recording instrumentations, see Appendix Chapter 16, Division II.

TABLE 16-A—UNIFORM AND CONCENTRATED LOADS

USE OR OCCUPANCY		UNIFORM LOAD <sup>1</sup> (pounds per square foot) × 0.3479 for kN/m <sup>2</sup>	CONCENTRATED LOAD (pounds) × 0.00448 for kN
Category	Description		
1. Access floor systems	Office use	50	2,000 <sup>2</sup>
	Computer use	100	2,000 <sup>2</sup>
2. Armories		150	0
3. Assembly areas <sup>3</sup> and auditoriums and balconies therewith	Fixed seating areas	50	0
	Movable seating and other areas	100	0
	Stage areas and enclosed platforms	125	0
4. Cornices and marquees		60 <sup>4</sup>	0
5. Exit facilities <sup>5</sup>		100	0 <sup>6</sup>
6. Garages	General storage and/or repair	100	7
	Private or pleasure-type motor vehicle storage	50	7
7. Hospitals	Wards and rooms	40	1,000 <sup>2</sup>
8. Libraries	Reading rooms	60	1,000 <sup>2</sup>
	Stack rooms	125	1,500 <sup>2</sup>
9. Manufacturing	Light	75	2,000 <sup>2</sup>
	Heavy	125	3,000 <sup>2</sup>
10. Offices		50	2,000 <sup>2</sup>
11. Printing plants	Press rooms	150	2,500 <sup>2</sup>
	Composing and linotype rooms	100	2,000 <sup>2</sup>
12. Residential <sup>8</sup>	Basic floor area	40	0 <sup>6</sup>
	Exterior balconies	50 <sup>4</sup>	0
	Decks	40 <sup>4</sup>	0
13. Restrooms <sup>9</sup>			
14. Reviewing stands, grandstands, bleachers, and folding and telescoping seating		100	0
15. Roof decks	Same as area served or for the type of occupancy accommodated		
16. Schools	Classrooms	40	1,000 <sup>2</sup>
17. Sidewalks and driveways	Public access	250	7
18. Storage	Light	125	
	Heavy	250	
19. Stores		100	3,000 <sup>2</sup>
20. Pedestrian bridges and walkways		100	

<sup>1</sup>See Section 1606 for live load reductions.

<sup>2</sup>See Section 1604.3, first paragraph, for area of load application.

<sup>3</sup>Assembly areas include such occupancies as dance halls, drill rooms, gymnasiums, playgrounds, plazas, terraces and similar occupancies which are generally accessible to the public.

<sup>4</sup>When snow loads occur that are in excess of the design conditions, the structure shall be designed to support the loads due to the increased loads caused by drift buildup or a greater snow design as determined by the building official. See Section 1605.4. For special-purpose roofs, see Section 1605.5.

<sup>5</sup>Exit facilities shall include such uses as corridors serving an occupant load of 10 or more persons, exterior exit balconies, stairways, fire escapes and similar uses.

<sup>6</sup>Individual stair treads shall be designed to support a 300-pound (1.33 kN) concentrated load placed in a position which would cause maximum stress. Stair stringers may be designed for the uniform load set forth in the table.

<sup>7</sup>See Section 1604.3, second paragraph, for concentrated loads. See Table 16-B for vehicle barriers.

<sup>8</sup>Residential occupancies include private dwellings, apartments and hotel guest rooms.

<sup>9</sup>Restroom loads shall not be less than the load for the occupancy with which they are associated, but need not exceed 50 pounds per square foot (2.4 kN/m<sup>2</sup>).

TABLE 16-B—SPECIAL LOADS<sup>1</sup>

USE		VERTICAL LOAD	LATERAL LOAD
Category	Description	(pounds per square foot unless otherwise noted)	
		× 0.0479 for kN/m <sup>2</sup>	
1. Construction, public access at site (live load)	Walkway, see Section 3303.6	150	
	Canopy, see Section 3303.7	150	
2. Grandstands, reviewing stands, bleachers, and folding and telescoping seating (live load)	Seats and footboards	120 <sup>2</sup>	See Footnote 3
3. Stage accessories (live load)	Catwalks	40	
	Followspot, projection and control rooms	50	
4. Ceiling framing (live load)	Over stages	20	
	All uses except over stages	10 <sup>4</sup>	
5. Partitions and interior walls, see Sec. 1609 (live load)			5
6. Elevators and dumbwaiters (dead and live loads)		2 × total loads <sup>5</sup>	
7. Mechanical and electrical equipment (dead load)		Total loads	
8. Cranes (dead and live loads)	Total load including impact increase	1.25 × total load <sup>6</sup>	0.10 × total load <sup>7</sup>
9. Balcony railings and guardrails	Exit facilities serving an occupant load greater than 50		50 <sup>8</sup>
	Other than exit facilities		20 <sup>8</sup>
	Components		25 <sup>9</sup>
10. Vehicle barriers	See Section 311.2.3.5		6,000 <sup>10</sup>
11. Handrails		See Footnote 11	See Footnote 11
12. Storage racks	Over 8 feet (2438 mm) high	Total loads <sup>12</sup>	See Table 16-O
13. Fire sprinkler structural support		250 pounds (1112 N) plus weight of water-filled pipe <sup>13</sup>	See Table 16-O
14. Explosion exposure	Hazardous occupancies, see Section 307.10		

<sup>1</sup>The tabulated loads are minimum loads. Where other vertical loads required by this code or required by the design would cause greater stresses, they shall be used.

<sup>2</sup>Pounds per lineal foot (× 14.6 for N/m).

<sup>3</sup>Lateral sway bracing loads of 24 pounds per foot (350 N/m) parallel and 10 pounds per foot (145.9 N/m) perpendicular to seat and footboards.

<sup>4</sup>Does not apply to ceilings which have sufficient total access from below, such that access is not required within the space above the ceiling. Does not apply to ceilings if the attic areas above the ceiling are not provided with access. This live load need not be considered as acting simultaneously with other live loads imposed upon the ceiling framing or its supporting structure.

<sup>5</sup>Where Appendix Chapter 30 has been adopted, see reference standard cited therein for additional design requirements.

<sup>6</sup>The impact factors included are for cranes with steel wheels riding on steel rails. They may be modified if substantiating technical data acceptable to the building official is submitted. Live loads on crane support girders and their connections shall be taken as the maximum crane wheel loads. For pendant-operated traveling crane support girders and their connections, the impact factors shall be 1.10.

<sup>7</sup>This applies in the direction parallel to the runway rails (longitudinal). The factor for forces perpendicular to the rail is 0.20 × the transverse traveling loads (trolley, cab, hooks and lifted loads). Forces shall be applied at top of rail and may be distributed among rails of multiple rail cranes and shall be distributed with due regard for lateral stiffness of the structures supporting these rails.

<sup>8</sup>A load per lineal foot (× 14.6 for N/m) to be applied horizontally at right angles to the top rail.

FOOTNOTES TO TABLE 16-B—(Continued)

- <sup>9</sup>Intermediate rails, panel fillers and their connections shall be capable of withstanding a load of 25 pounds per square foot (1.2 kN/m<sup>2</sup>) applied horizontally at right angles over the entire tributary area, including openings and spaces between rails. Reactions due to this loading need not be combined with those of Footnote 8.
- <sup>10</sup>A horizontal load in pounds (N) applied at right angles to the vehicle barrier at a height of 13 inches (457 mm) above the parking surface. The force may be distributed over a 1-foot-square (304.8-milimeter-square) area.
- <sup>11</sup>The mounting of handrails shall be such that the completed handrail and supporting structure are capable of withstanding a load of at least 200 pounds (890 N) applied in any direction at any point on the rail. These loads shall not be assumed to act cumulatively with Item 9.
- <sup>12</sup>Vertical members of storage racks shall be protected from impact forces of operating equipment, or racks shall be designed so that failure of one vertical member will not cause collapse of more than the bay or bays directly supported by that member.
- <sup>13</sup>The 250-pound (1.11 kN) load is to be applied to any single fire sprinkler support point but not simultaneously to all support joints.

TABLE 16-C—MINIMUM ROOF LIVE LOADS<sup>1</sup>

ROOF SLOPE	METHOD 1			METHOD 2		
	Tributary Loaded Area in Square Feet for Any Structural Member			Uniform Load <sup>2</sup> (pounds per square foot)	Rate of Reduction <i>r</i> (percentage)	Maximum Reduction <i>R</i> (percentage)
	× 0.0929 for m <sup>2</sup>					
	0 to 200	201 to 600	Over 600			
	Uniform Load (pounds per square foot)			× 0.0479 for kN/m <sup>2</sup>		
1. Flat <sup>3</sup> or rise less than 4 units vertical in 12 units horizontal (33.3% slope). Arch or dome with rise less than one eighth of span	20	16	12	20	.08	40
2. Rise 4 units vertical to less than 12 units vertical in 12 units horizontal (33% to less than 100% slope). Arch or dome with rise one eighth of span to less than three eighths of span	16	14	12	16	.06	25
3. Rise 12 units vertical in 12 units horizontal (100% slope) and greater. Arch or dome with rise three eighths of span or greater	12	12	12	12	No reductions permitted	
4. Awnings except cloth covered <sup>4</sup>	5	5	5	5		
5. Greenhouses, lath houses and agricultural buildings <sup>5</sup>	10	10	10	10		

<sup>1</sup>Where snow loads occur, the roof structure shall be designed for such loads as determined by the building official. See Section 1605.4. For special-purpose roofs, see Section 1605.5.  
<sup>2</sup>See Section 1606 for live load reductions. The rate of reduction *r* in Section 1606 Formula (6-1) shall be as indicated in the table. The maximum reduction *R* shall not exceed the value indicated in the table.  
<sup>3</sup>A flat roof is any roof with a slope of less than 1/4 unit vertical in 12 units horizontal (2% slope). The live load for flat roofs is in addition to the ponding load required by Section 1605.6.  
<sup>4</sup>As defined in Section 3206.  
<sup>5</sup>See Section 1605.5 for concentrated load requirements for greenhouse roof members.

TABLE 16-D—MAXIMUM ALLOWABLE DEFLECTION FOR STRUCTURAL MEMBERS<sup>1</sup>

TYPE OF MEMBER	MEMBER LOADED WITH LIVE LOAD ONLY (L.L.)	MEMBER LOADED WITH LIVE LOAD PLUS DEAD LOAD (L.L. + K.D.L.)
Roof member supporting plaster or floor member	$L/360$	$L/240$

<sup>1</sup>Sufficient slope or camber shall be provided for flat roofs in accordance with Section 1605.6.

L.L.—live load.

D.L.—dead load.

K—factor as determined by Table 16-E.

L—length of member in same units as deflection.

TABLE 16-E—VALUE OF "K"

WOOD		REINFORCED CONCRETE <sup>2</sup>	STEEL
Unseasoned	Seasoned <sup>1</sup>		
1.0	0.5	$T/(1+50\rho')$	0

<sup>1</sup>Seasoned lumber is lumber having a moisture content of less than 16 percent at time of installation and used under dry conditions of use such as in covered structures.

<sup>2</sup>See also Section 1909 for definitions and other requirements.

$\rho'$  shall be the value at midspan for simple and continuous spans, and at support for cantilevers. Time-dependent factor  $T$  for sustained loads may be taken equal to:

five years or more	2.0
twelve months	1.2
six months	1.4
three months	1.0

TABLE 16-F—WIND STAGNATION PRESSURE ( $q_s$ ) AT STANDARD HEIGHT OF 33 FEET (10 058 mm)

Basic wind speed (mph) <sup>1</sup> ( $\times 1.61$ for km/h)	70	80	90	100	110	120	130
Pressure $q_s$ (psf) ( $\times 0.0479$ for kN/m <sup>2</sup> )	12.6	16.4	20.8	25.6	31.0	36.9	43.3

<sup>1</sup>Wind speed from Section 1615.

TABLE 16-G—COMBINED HEIGHT, EXPOSURE AND GUST FACTOR COEFFICIENT ( $C_e$ )<sup>1</sup>

HEIGHT ABOVE AVERAGE LEVEL OF ADJOINING GROUND (feet) $\times 304.8$ for mm	EXPOSURE D	EXPOSURE C	EXPOSURE B
	0-15	1.39	1.06
20	1.45	1.13	0.67
25	1.50	1.19	0.72
30	1.54	1.23	0.76
40	1.62	1.31	0.84
60	1.73	1.43	0.95
80	1.81	1.53	1.04
100	1.88	1.61	1.13
120	1.93	1.67	1.20
160	2.02	1.79	1.31
200	2.10	1.87	1.42
300	2.23	2.05	1.63
400	2.34	2.19	1.80

<sup>1</sup>Values for intermediate heights above 15 feet (4572 mm) may be interpolated.

TABLE 16-H—PRESSURE COEFFICIENTS ( $C_q$ )

STRUCTURE OR PART THEREOF	DESCRIPTION	$C_q$ FACTOR
1. Primary frames and systems	<b>Method 1</b> (Normal force method) Walls: Windward wall Leeward wall Roofs <sup>1</sup> : Wind perpendicular to ridge Leeward roof or flat roof Windward roof less than 2:12 (16.7%) Slope 2:12 (16.7%) to less than 9:12 (75%)  Slope 9:12 (75%) to 12:12 (100%) Slope > 12:12 (100%) Wind parallel to ridge and flat roofs	0.8 inward 0.5 outward  0.7 outward  0.7 outward 0.9 outward or 0.3 inward 0.4 inward 0.7 inward 0.7 outward
	<b>Method 2</b> (Projected area method) On vertical projected area Structures 40 feet (12 192 mm) or less in height Structures over 40 feet (12 192 mm) in height On horizontal projected area <sup>1</sup>	1.3 horizontal any direction 1.4 horizontal any direction 0.7 upward
2. Elements and components not in areas of discontinuity <sup>2</sup>	Wall elements All structures Enclosed and unenclosed structures Partially enclosed structures Parapets walls	1.2 inward 1.2 outward 1.6 outward 1.3 inward or outward
	Roof elements <sup>3</sup> Enclosed and unenclosed structures Slope < 7:12 (58.3%) Slope 7:12 (58.3%) to 12:12 (100%)  Partially enclosed structures Slope < 2:12 (16.7%) Slope 2:12 (16.7%) to 7:12 (58.3%)  Slope > 7:12 (58.3%) to 12:12 (100%)	1.3 outward 1.3 outward or inward  1.7 outward 1.6 outward or 0.8 inward 1.7 outward or inward
3. Elements and components in areas of discontinuities <sup>2,4,5</sup>	Wall corners <sup>6</sup>	1.5 outward or 1.2 inward
	Roof eaves, rakes or ridges without overhangs <sup>6</sup> Slope < 2:12 (16.7%) Slope 2:12 (16.7%) to 7:12 (58.3%) Slope > 7:12 (58.3%) to 12:12 (100%) For slopes less than 2:12 (16.7%) Overhangs at roof eaves, rakes or ridges, and canopies	2.3 upward 2.6 outward 1.6 outward 0.5 added to values above
4. Chimneys, tanks and solid towers	Square or rectangular Hexagonal or octagonal Round or elliptical	1.4 any direction 1.1 any direction 0.8 any direction
5. Open-frame towers <sup>7,8</sup>	Square and rectangular Diagonal Normal Triangular	4.0 3.6 3.2
6. Tower accessories (such as ladders, conduit, lights and elevators)	Cylindrical members 2 inches (51 mm) or less in diameter Over 2 inches (51 mm) in diameter Flat or angular members	1.0 0.8 1.3
7. Signs, flagpoles, lightpoles, minor structures <sup>8</sup>		1.4 any direction

(Continued)

## FOOTNOTES TO TABLE 16-H

- <sup>1</sup>For one story or the top story of multistory partially enclosed structures, an additional value of 0.5 shall be added to the outward  $C_q$ . The most critical combination shall be used for design. For definition of partially enclosed structures, see Section 1614.
- <sup>2</sup> $C_q$  values listed are for 10-square-foot (0.93 m<sup>2</sup>) tributary areas. For tributary areas of 100 square feet (9.29 m<sup>2</sup>), the value of 0.3 may be subtracted from  $C_q$ , except for areas at discontinuities with slopes less than 7 units vertical in 12 units horizontal (58.3% slope) where the value of 0.8 may be subtracted from  $C_q$ . Interpolation may be used for tributary areas between 10 and 100 square feet (0.93 m<sup>2</sup> and 9.29 m<sup>2</sup>). For tributary areas greater than 1,000 square feet (92.9 m<sup>2</sup>), use primary frame values.
- <sup>3</sup>For slopes greater than 12 units vertical in 12 units horizontal (100% slope), use wall element values.
- <sup>4</sup>Local pressures shall apply over a distance from the discontinuity of 10 feet (3048 mm) or 0.1 times the least width of the structure, whichever is smaller.
- <sup>5</sup>Discontinuities at wall corners or roof ridges are defined as discontinuous breaks in the surface where the included interior angle measures 170 degrees or less.
- <sup>6</sup>Load is to be applied on either side of discontinuity but not simultaneously on both sides.
- <sup>7</sup>Wind pressures shall be applied to the total normal projected area of all elements on one face. The forces shall be assumed to act parallel to the wind direction.
- <sup>8</sup>Factors for cylindrical elements are two thirds of those for flat or angular elements.

TABLE 16-I—SEISMIC ZONE FACTOR Z

ZONE	1	2A	2B	3	4
Z	0.075	0.15	0.20	0.30	0.40

The zone shall be determined from the seismic zone map in Figure 16-2.

TABLE 16-J—SITE COEFFICIENTS<sup>1</sup>

TYPE	DESCRIPTION	S FACTOR
S <sub>1</sub>	A soil profile with either: (a) A rock-like material characterized by a shear-wave velocity greater than 2,500 feet per second (762 m/s) or by other suitable means of classification, or (b) Medium-dense to dense or medium-stiff to stiff soil conditions, where soil depth is less than 200 feet (60 960 mm).	1.0
S <sub>2</sub>	A soil profile with predominantly medium-dense to dense or medium-stiff to stiff soil conditions, where the soil depth exceeds 200 feet (60 960 mm).	1.2
S <sub>3</sub>	A soil profile containing more than 20 feet (6096 mm) of soft to medium-stiff clay but not more than 40 feet (12 192 mm) of soft clay.	1.5
S <sub>4</sub>	A soil profile containing more than 40 feet (12 192 mm) of soft clay characterized by a shear wave velocity less than 500 feet per second (152.4 m/s).	2.0

<sup>1</sup>The site factor shall be established from properly substantiated geotechnical data. In locations where the soil properties are not known in sufficient detail to determine the soil profile type, soil profile S<sub>3</sub> shall be used. Soil profile S<sub>4</sub> need not be assumed unless the building official determines that soil profile S<sub>4</sub> may be present at the site, or in the event that soil profile S<sub>4</sub> is established by geotechnical data.

TABLE 16-K—OCCUPANCY CATEGORY

OCCUPANCY CATEGORY	OCCUPANCY OR FUNCTIONS OF STRUCTURE	SEISMIC IMPORTANCE FACTOR, $I_p$	SEISMIC IMPORTANCE FACTOR, $I_p$	WIND IMPORTANCE FACTOR, $I_w$
1. Essential facilities <sup>2</sup>	Group I, Division 1 Occupancies having surgery and emergency treatment areas Fire and police stations Garages and shelters for emergency vehicles and emergency aircraft Structures and shelters in emergency-preparedness centers Aviation control towers Structures and equipment in government communication centers and other facilities required for emergency response Standby power-generating equipment for Category 1 facilities Tanks or other structures containing housing or supporting water or other fire-suppression material or equipment required for the protection of Category 1, 2 or 3 structures	1.25	1.50	1.15
2. Hazardous facilities	Group H, Divisions 1, 2, 6 and 7 Occupancies and structures therein housing or supporting toxic or explosive chemicals or substances Nonbuilding structures housing, supporting or containing quantities of toxic or explosive substances which, if contained within a building, would cause that building to be classified as a Group H, Division 1, 2 or 7 Occupancy	1.25	1.50	1.15
3. Special occupancy structures <sup>3</sup>	Group A, Divisions 1, 2 and 2.1 Occupancies Buildings housing Group E, Divisions 1 and 3 Occupancies with a capacity greater than 300 students Buildings housing Group B Occupancies used for college or adult education with a capacity greater than 500 students Group I, Divisions 1 and 2 Occupancies with 50 or more resident incapacitated patients, but not included in Category 1 Group I, Division 3 Occupancies All structures with an occupancy greater than 5,000 persons Structures and equipment in power-generating stations; and other public utility facilities not included in Category 1 or Category 2 above, and required for continued operation	1.00	1.00	1.00
4. Standard occupancy structures <sup>3</sup>	All structures housing occupancies or having functions not listed in Category 1, 2 or 3 and Group U Occupancy towers	1.00	1.00	1.00
5. Miscellaneous structures	Group U Occupancies except for towers	1.00	1.00	1.00

<sup>1</sup>The limitation of  $I_p$  for panel connections in Section 1631.2.4 shall be 1.0 for the entire connector.

<sup>2</sup>Structural observation requirements are given in Sections 108, 1701 and 1702.

<sup>3</sup>For anchorage of machinery and equipment required for life-safety systems the value of  $I_p$  shall be taken as 1.5.

TABLE 16-L—VERTICAL STRUCTURAL IRREGULARITIES

IRREGULARITY TYPE AND DEFINITION	REFERENCE SECTION
1. <b>Stiffness irregularity—soft story</b> A soft story is one in which the lateral stiffness is less than 70 percent of that in the story above or less than 80 percent of the average stiffness of the three stories above.	1627.8.3, Item 2
2. <b>Weight (mass) irregularity</b> Mass irregularity shall be considered to exist where the effective mass of any story is more than 150 percent of the effective mass of an adjacent story. A roof which is lighter than the floor below need not be considered.	1627.8.3, Item 2
3. <b>Vertical geometric irregularity</b> Vertical geometric irregularity shall be considered to exist where the horizontal dimension of the lateral force-resisting system in any story is more than 130 percent of that in an adjacent story. One-story penthouses need not be considered.	1627.8.3, Item 2
4. <b>In-plane discontinuity in vertical lateral-force-resisting element</b> An in-plane offset of the lateral load-resisting elements greater than the length of those elements.	1628.7
5. <b>Discontinuity in capacity—weak story</b> A weak story is one in which the story strength is less than 80 percent of that in the story above. The story strength is the total strength of all seismic-resisting elements sharing the story shear for the direction under consideration.	1627.9.1

TABLE 16-M—PLAN STRUCTURAL IRREGULARITIES

IRREGULARITY TYPE AND DEFINITION	REFERENCE SECTION
1. <b>Torsional irregularity—to be considered when diaphragms are not flexible</b> Torsional irregularity shall be considered to exist when the maximum story drift, computed including accidental torsion, at one end of the structure transverse to an axis is more than 1.2 times the average of the story drifts of the two ends of the structure.	1631.2.9, Item 6
2. <b>Reentrant corners</b> Plan configurations of a structure and its lateral force-resisting system contain reentrant corners, where both projections of the structure beyond a reentrant corner are greater than 15 percent of the plan dimension of the structure in the given direction.	1631.2.9, Items 6 and 7
3. <b>Diaphragm discontinuity</b> Diaphragms with abrupt discontinuities or variations in stiffness, including those having cutout or open areas greater than 50 percent of the gross enclosed area of the diaphragm, or changes in effective diaphragm stiffness of more than 50 percent from one story to the next.	1631.2.9, Item 6
4. <b>Out-of-plane offsets</b> Discontinuities in a lateral force path, such as out-of-plane offsets of the vertical elements.	1628.7; 1631.2.9, Item 6; 2211.8
5. <b>Nonparallel systems</b> The vertical lateral load-resisting elements are not parallel to or symmetric about the major orthogonal axes of the lateral force-resisting system.	1631.1

TABLE 16-N—STRUCTURAL SYSTEMS

BASIC STRUCTURAL SYSTEM <sup>1</sup>	LATERAL-FORCE-RESISTING SYSTEM—DESCRIPTION	$R_W$ <sup>2</sup>	$H^3$
			× 304.8 for mm
1. Bearing wall system	1. Light-framed walls with shear panels	8	65
	a. Wood structural panel walls for structures three stories or less	6	65
	b. All other light-framed walls		
	2. Shear walls		
	a. Concrete	6	160
	b. Masonry	6	160
	3. Light steel-framed bearing walls with tension-only bracing	4	65
	4. Braced frames where bracing carries gravity loads		
	a. Steel	6	160
	b. Concrete <sup>4</sup>	4	—
c. Heavy timber	4	65	
2. Building frame system	1. Steel eccentrically braced frame (EBF)	10	240
	2. Light-framed walls with shear panels		
	a. Wood structural panel walls for structures three stories or less	9	65
	b. All other light-framed walls	7	65
	3. Shear walls		
	a. Concrete	8	240
	b. Masonry	8	160
	4. Ordinary braced frames		
	a. Steel	8	160
	b. Concrete <sup>4</sup>	8	—
c. Heavy timber	8	65	
5. Special concentrically braced frames			
a. Steel	9	240	
3. Moment-resisting frame system	1. Special moment-resisting frames (SMRF)		
	a. Steel	12	N.L.
	b. Concrete	12	N.L.
	2. Masonry moment-resisting wall frame	9	160
	3. Concrete intermediate moment-resisting frames (IMRF) <sup>5</sup>	8	—
	4. Ordinary moment-resisting frames (OMRF)		
a. Steel <sup>6</sup>	6	160	
b. Concrete <sup>7</sup>	5	—	
4. Dual systems	1. Shear walls		
	a. Concrete with SMRF	12	N.L.
	b. Concrete with steel OMRF	6	160
	c. Concrete with concrete IMRF <sup>5</sup>	9	160
	d. Masonry with SMRF	8	160
	e. Masonry with steel OMRF	6	160
	f. Masonry with concrete IMRF <sup>4</sup>	7	—
	2. Steel EBF		
	a. With steel SMRF	12	N.L.
	b. With steel OMRF	6	160
	3. Ordinary braced frames		
	a. Steel with steel SMRF	10	N.L.
	b. Steel with steel OMRF	6	160
	c. Concrete with concrete SMRF <sup>4</sup>	9	—
	d. Concrete with concrete IMRF <sup>4</sup>	6	—
	4. Special concentrically braced frames		
a. Steel with steel SMRF	11	N.L.	
b. Steel with steel OMRF	6	160	
5. Undefined systems	See Sections 1627.8.3 and 1627.9.2	—	—

N.L.—No limit.

<sup>1</sup>Basic structural systems are defined in Section 1627.6.<sup>2</sup>See Section 1628.3 for combination of structural system.<sup>3</sup> $H$ —Height limit applicable to Seismic Zones 3 and 4. See Section 1627.7.<sup>4</sup>Prohibited in Seismic Zones 3 and 4.<sup>5</sup>Prohibited in Seismic Zones 3 and 4, except as permitted in Section 1632.2.

(Continued)

## FOOTNOTES TO TABLE 16-N—(Continued)

<sup>6</sup>Ordinary moment-resisting frames in Seismic Zone 1 meeting the requirements of Section 2211.6 may use an  $R_w$  value of 12.

<sup>7</sup>Prohibited in Seismic Zones 2A, 2B, 3 and 4. See Section 1631.2.7.

TABLE 16-O—HORIZONTAL FORCE FACTOR,  $C_p$ 

ELEMENTS OF STRUCTURES, NONSTRUCTURAL COMPONENTS AND EQUIPMENT <sup>1</sup>	VALUE OF $C_p$	FOOTNOTE
<b>1. Elements of structures</b>		
1. Walls including the following:		
a. Unbraced (cantilevered) parapets	2.00	
b. Other exterior walls above the ground floor	0.75	2,3
c. All interior bearing and nonbearing walls and partitions	0.75	3
d. Masonry or concrete fences over 6 feet (1829 mm) high	0.75	
2. Penthouse (except when framed by an extension of the structural frame)	0.75	
3. Connections for prefabricated structural elements other than walls, with force applied at center of gravity	0.75	4
4. Diaphragms	--	5
<b>2. Nonstructural components</b>		
1. Exterior and interior ornamentations and appendages	2.00	
2. Chimneys, stacks, trussed towers and tanks on legs:		
a. Supported on or projecting as an unbraced cantilever above the roof more than one half their total height	2.00	
b. All others, including those supported below the roof with unbraced projection above the roof less than one half its height, or braced or guyed to the structural frame at or above their centers of mass	0.75	
3. Signs and billboards	2.00	
4. Storage racks (include contents)	0.75	10
5. Anchorage for permanent floor-supported cabinets and book stacks more than 5 feet (1524 mm) in height (include contents)	0.75	
6. Anchorage for suspended ceilings and light fixtures	0.75	4,6,7,11
7. Access floor systems	0.75	4,9
<b>3. Equipment</b>		
1. Tanks and vessels (include contents), including support systems and anchorage	0.75	
2. Electrical, mechanical and plumbing equipment and associated conduit, ductwork and piping, and machinery	0.75	8

<sup>1</sup>See Section 1630.2 for items supported at or below grade.

<sup>2</sup>See Section 1631.2.4 and Section 1630.2.

<sup>3</sup>Where flexible diaphragms, as defined in Section 1628.5, provide lateral support for walls and partitions, the value of  $C_p$  for anchorage shall be increased 50 percent for the center one half of the diaphragm span.

<sup>4</sup>Applies to Seismic Zones 2, 3 and 4 only.

<sup>5</sup>See Section 1631.2.9.

<sup>6</sup>Ceiling weight shall include all light fixtures and other equipment or partitions which are laterally supported by the ceiling. For purposes of determining the seismic force, a ceiling weight of not less than 4 pounds per square foot (19.5 kg/m<sup>2</sup>) shall be used.

<sup>7</sup>Ceilings constructed of lath and plaster or gypsum board screw or nail attached to suspended members that support a ceiling at one level extending from wall to wall need not be analyzed provided the walls are not over 50 feet (15 240 mm) apart.

<sup>8</sup>Equipment includes, but is not limited to, boiler, chiller, heat exchanger, pump, air-handling unit, cooling tower, control panel, motor, switch gear, transformer and life-safety equipment. It includes major conduit, ducting and piping serving such machinery and equipment and fire sprinkler systems. See Section 1630.2 for additional requirements for determining  $C_p$  for nonrigid or flexibly mounted equipment.

<sup>9</sup> $W_p$  for access floor systems shall be the dead load of the access floor system plus 25 percent of the floor live load plus a 10 psf (0.479 kN/m<sup>2</sup>) partition load allowance.

<sup>10</sup>In lieu of the tabulated values, steel storage racks may be designed in accordance with Chapter 22, Division VI.

<sup>11</sup>Light fixtures and mechanical services installed in metal suspension systems for acoustical tile and lay-in panel ceilings shall be independently supported from the structure above as specified in U.B.C. Standard 25-2, Part III.

TABLE 16-P— $R_w$  FACTORS FOR NONBUILDING STRUCTURIES

STRUCTURE TYPE	$R_w$
1. Vessels, including tanks and pressurized spheres, on braced or unbraced legs.	3
2. Cast-in-place concrete silos and chimneys having walls continuous to the foundation.	5
3. Distributed mass cantilever structures such as stacks, chimneys, silos and skirt-supported vertical vessels.	4
4. Trussed towers (freestanding or guyed), guyed stacks and chimneys.	4
5. Inverted pendulum-type structures.	3
6. Cooling towers.	5
7. Bins and hoppers on braced or unbraced legs.	4
8. Storage racks.	5
9. Signs and billboards.	5
10. Amusement structures and monuments.	3
11. All other self-supporting structures not otherwise covered.	4

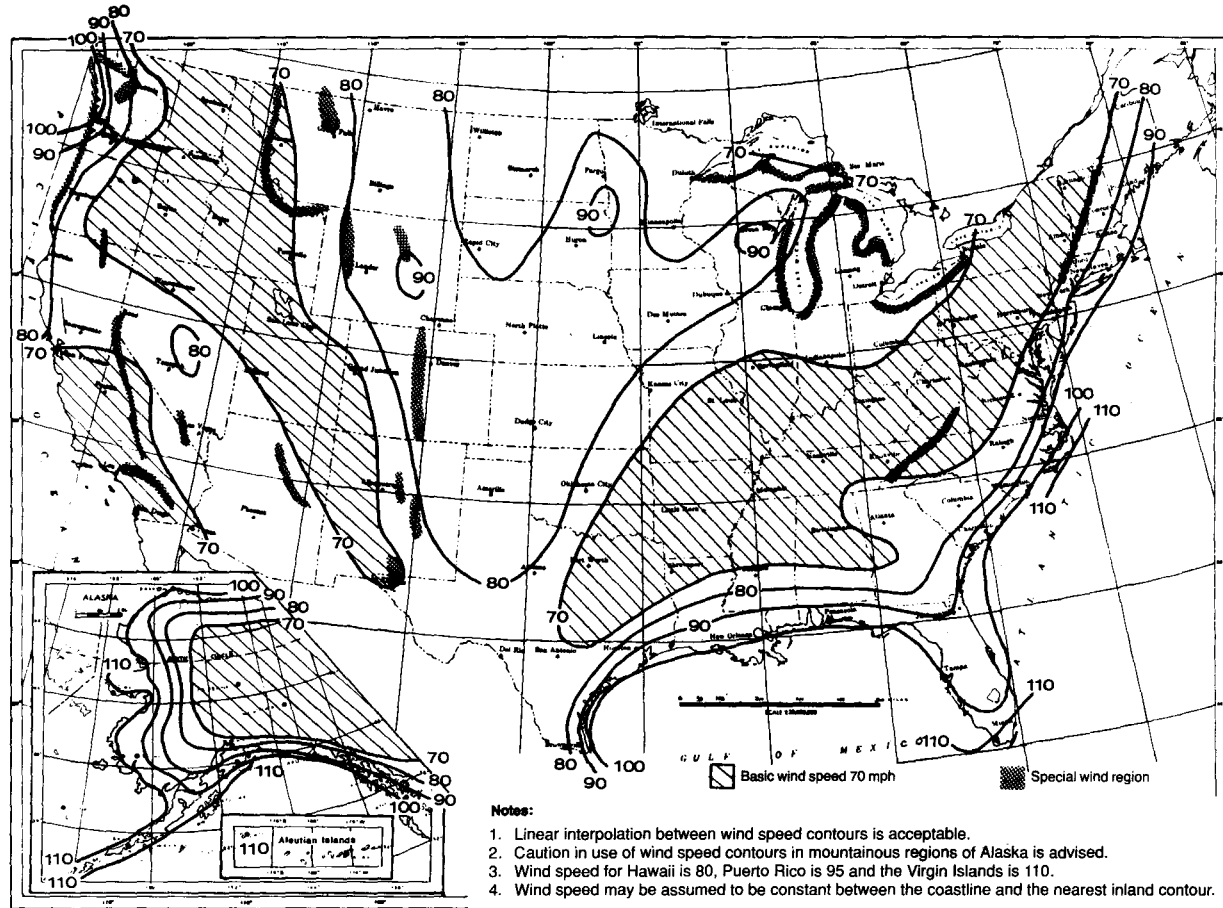
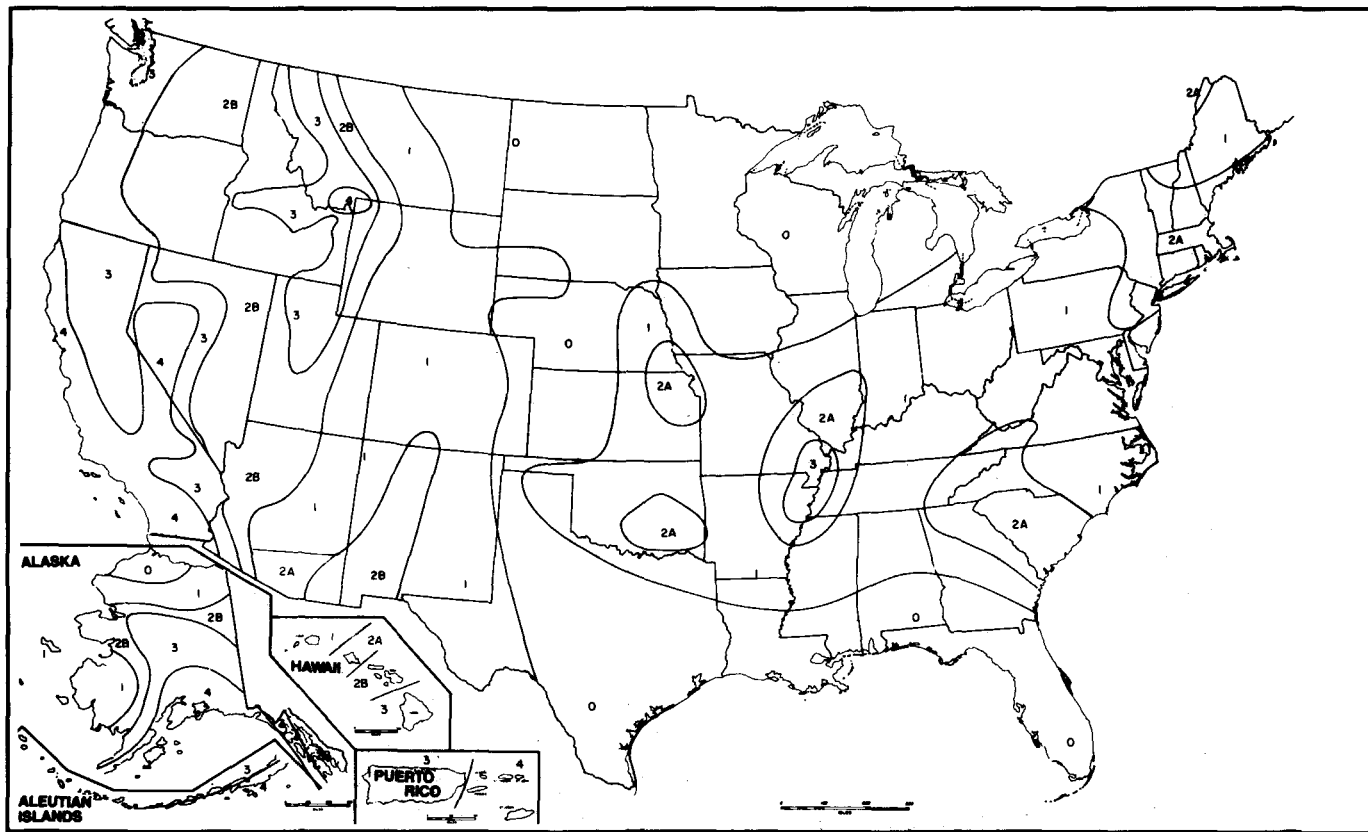

FIGURE 16-1—MINIMUM BASIC WIND SPEEDS IN MILES PER HOUR (× 1.61 for km/h)



**FIGURE 16-2—SEISMIC ZONE MAP OF THE UNITED STATES**  
For areas outside of the United States, see Appendix Chapter 16.

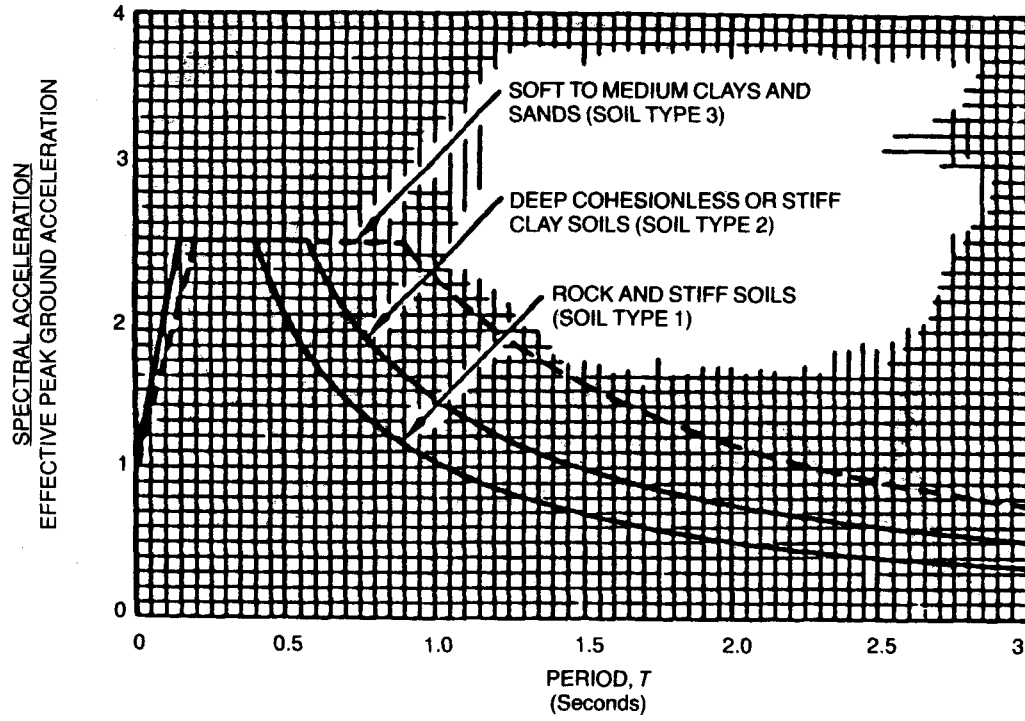

FIGURE 16-3—NORMALIZED RESPONSE SPECTRA SHAPES

## Chapter 17 STRUCTURAL TESTS AND INSPECTIONS

### SECTION 1701 — SPECIAL INSPECTIONS

**1701.1 General.** In addition to the inspections required by Section 108, the owner or the engineer or architect of record acting as the owner's agent shall employ one or more special inspectors who shall provide inspections during construction on the types of work listed under Section 1701.5.

**EXCEPTION:** The building official may waive the requirement for the employment of a special inspector if the construction is of a minor nature.

**1701.2 Special Inspector.** The special inspector shall be a qualified person who shall demonstrate competence, to the satisfaction of the building official, for inspection of the particular type of construction or operation requiring special inspection.

**1701.3 Duties and Responsibilities of the Special Inspector.** The special inspector shall observe the work assigned for conformance with the approved design drawings and specifications.

The special inspector shall furnish inspection reports to the building official, the engineer or architect of record, and other designated persons. All discrepancies shall be brought to the immediate attention of the contractor for correction, then, if uncorrected, to the proper design authority and to the building official.

The special inspector shall submit a final signed report stating whether the work requiring special inspection was, to the best of the inspector's knowledge, in conformance with the approved plans and specifications and the applicable workmanship provisions of this code.

**1701.4 Standards of Quality.** The standards listed below labeled a "U.B.C. standard" are also listed in Chapter 35, Part II, and are part of this code.

**1. Concrete.**

U.B.C. Standard 19-3, Ready-mixed Concrete

**2. Connections.**

Chapter 22, Division IV, High-strength Bolting

**3. Fireproofing.**

U.B.C. Standard 7-6, Thickness and Density Determination for Spray-applied Fireproofing

**1701.5 Types of Work.** Except as provided in Section 1701.1, the types of work listed below shall be inspected by a special inspector.

**1. Concrete.** During the taking of test specimens and placing of reinforced concrete. See Item 12 for shotcrete.

**EXCEPTIONS:** 1. Concrete for foundations conforming to minimum requirements of Table 18-I-D or for Group R, Division 3 or Group U, Division 1 Occupancies, provided the building official finds that a special hazard does not exist.

2. For foundation concrete, other than cast-in-place drilled piles or caissons, where the structural design is based on an  $f'_c$  no greater than 2,500 pounds per square inch (psi) (17.2 MPa).

3. Nonstructural slabs on grade, including prestressed slabs on grade when effective prestress in concrete is less than 150 psi. (1.03 MPa).

4. Site work concrete fully supported on earth and concrete where no special hazard exists.

**2. Bolts installed in concrete.** Prior to and during the placement of concrete around bolts when stress increases permitted by Footnote 5 of Table 19-E or Section 1925 are utilized.

**3. Special moment-resisting concrete frame.** As required by Section 1921.9 of this code.

#### 4. Reinforcing steel and prestressing steel tendons.

- 4.1 During all stressing and grouting of tendons in prestressed concrete.
- 4.2 During placing of reinforcing steel and prestressing tendons for all concrete required to have special inspection by Item 1.

**EXCEPTION:** The special inspector need not be present continuously during placing of reinforcing steel and prestressing tendons, provided the special inspector has inspected for conformance with the approved plans prior to the closing of forms or the delivery of concrete to the jobsite.

#### 5. Structural welding.

- 5.1 **General.** During the welding of any member or connection which is designed to resist loads and forces required by this code.

**EXCEPTIONS:** 1. Welding done in an approved fabricator's shop in accordance with Section 1701.7.

2. The special inspector need not be continuously present during welding of the following items, provided the materials, qualifications of welding procedures and welders are verified prior to the start of work; periodic inspections are made of work in progress; and a visual inspection of all welds is made prior to completion or prior to shipment of shop welding:

- 2.1 Single-pass fillet welds not exceeding  $5/16$  inch (7.9 mm) in size.
- 2.2 Floor and roof deck welding.
- 2.3 Welded studs when used for structural diaphragm or composite systems.
- 2.4 Welded sheet steel for cold-formed steel framing members such as studs and joists.
- 2.5 Welding of stairs and railing systems.

- 5.2 **Special moment-resisting steel frames.** During the welding of special moment-resisting steel frames. In addition to Item 5.1 requirements above, nondestructive testing as required by Section 1703 of this code.

- 5.3 **Welding of reinforcing steel.** During the welding of reinforcing steel.

**EXCEPTION:** The special inspector need not be continuously present during the welding of ASTM A 706 reinforcing steel not larger than No. 5 bars used for embedments, provided the materials, qualifications of welding procedures and welders are verified prior to the start of work; periodic inspections are made of work in progress; and a visual inspection of all welds is made prior to completion or prior to shipment of shop welding.

6. **High-strength bolting.** As required by Chapter 22, Division IV. Such inspections may be performed on a periodic basis in accordance with the requirements of Section 1701.6.

#### 7. Structural masonry.

- 7.1 For masonry, other than fully grouted open-end hollow-unit masonry, during preparation and taking of any required prisms or test specimens, placing of all masonry units, placement of reinforcement, inspection of grout space, immediately prior to closing of clean-outs, and during all grouting operations.

**EXCEPTION:** For hollow-unit masonry where the  $f'_m$  is no more than 1,500 psi (10.34 MPa) for concrete units or 2,600 psi (17.93 MPa) for clay units, special inspection may be performed as required for fully grouted open-end hollow-unit masonry specified in Item 7.2 below.

- 7.2 For fully grouted open-end hollow-unit masonry during preparation and taking of any required prisms or test specimens, at the start of laying units, after the placement of reinforcing steel, grout space prior to each grouting operation, and during all grouting operations.

**EXCEPTION:** Special inspection as required in Items 7.1 and 7.2 above need not be provided when design stresses have been adjusted as specified in Chapter 21 to permit noncontinuous inspection.

8. **Reinforced gypsum concrete.** When cast-in-place Class B gypsum concrete is being mixed and placed.

9. **Insulating concrete fill.** During the application of insulating concrete fill when used as part of a structural system.

**EXCEPTION:** The special inspections may be limited to an initial inspection to check the deck surface and placement of reinforcing. The special inspector shall supervise the preparation of compression test specimens during this initial inspection.

10. **Spray-applied fireproofing.** As required by U.B.C. Standard 7-6.

11. **Piling, drilled piers and caissons.** During driving and testing of piles and construction of cast-in-place drilled piles or caissons. See Items 1 and 4 for concrete and reinforcing steel inspection.

12. **Shotcrete.** During the taking of test specimens and placing of all shotcrete and as required by Sections 1922.10 and 1922.11.

**EXCEPTION:** Shotcrete work fully supported on earth, minor repairs and when, in the opinion of the building official, no special hazard exists.

13. **Special grading, excavation and filling.** During earth-work excavations, grading and filling operations inspection to satisfy requirements of Chapter 18 and Appendix Chapter 33 of this code.

14. **Smoke-control system.**

14.1 During erection of ductwork and prior to concealment for the purposes of leakage testing and recording of device location.

14.2 Prior to occupancy and after sufficient completion for the purposes of pressure difference testing, flow measurements, and detection and control verification.

15. **Special cases.** Work which, in the opinion of the building official, involves unusual hazards or conditions.

#### **1701.6 Continuous and Periodic Special Inspection.**

**1701.6.1 Continuous special inspection.** Continuous special inspection means that the special inspector is on the site at all times observing the work requiring special inspection.

**1701.6.2 Periodic special inspection.** Some inspections may be made on a periodic basis and satisfy the requirements of continuous inspection, provided this periodic scheduled inspection is performed as outlined in the project plans and specifications and approved by the building official.

**1701.7 Approved Fabricators.** Special inspections required by this section and elsewhere in this code are not required where the work is done on the premises of a fabricator registered and approved by the building official to perform such work without special inspection. The certificate of registration shall be subject to revocation by the building official if it is found that any work done pursuant to the approval is in violation of this code. The approved fabricator shall submit a certificate of compliance that the work was performed in accordance with the approved plans and specifications to the building official and to the engineer or architect of record. The approved fabricator's qualifications shall be contingent on compliance with the following:

1. The fabricator has developed and submitted a detailed fabrication procedural manual reflecting key quality control procedures which will provide a basis for inspection control of workmanship and the fabricator plant.

2. Verification of the fabricator's quality control capabilities, plant and personnel as outlined in the fabrication procedural manual shall be by an approved inspection or quality control agency.

3. Periodic plant inspections shall be conducted by an approved inspection or quality control agency to monitor the effectiveness of the quality control program.

4. It shall be the responsibility of the inspection or quality control agency to notify the approving authority in writing of any change to the procedural manual. Any fabricator approval may be revoked for just cause. Reapproval of the fabricator shall be contingent on compliance with quality control procedures during the past year.

#### **SECTION 1702 — STRUCTURAL OBSERVATION**

Structural observation shall be provided in Seismic Zone 3 or 4 when one of the following conditions exists:

1. The structure is defined in Table 16-K as Occupancy Category I, II or III, or
2. The structure is required to comply with Section 403, or
3. When so designated by the architect or engineer of record, or
4. When such observation is specifically required by the building official.

The owner shall employ the engineer or architect responsible for the structural design, or another engineer or architect designated by the engineer or architect responsible for the structural design, to perform structural observation as defined in Section 220. Observed deficiencies shall be reported in writing to the owner's representative, special inspector, contractor and the building official. The structural observer shall submit to the building official a written statement that the site visits have been made and identifying any reported deficiencies which, to the best of the structural observer's knowledge, have not been resolved.

### SECTION 1703 — NONDESTRUCTIVE TESTING

In Seismic Zones 3 and 4, welded connections between the primary members of special moment-resisting frames shall be tested by nondestructive methods for compliance with approved standards and job specifications. This testing shall be a part of the special inspection requirements of Section 1701.5. A program for this testing shall be established by the person responsible for structural design and as shown on plans and specifications.

As a minimum, this program shall include the following:

1. All complete penetration groove welds contained in joints and splices shall be tested 100 percent either by ultrasonic testing or by radiography.

**EXCEPTION:** When approved, the nondestructive testing rate for an individual welder or welding operator may be reduced to 25 percent, provided the reject rate is demonstrated to be 5 percent or less of the welds tested for the welder or welding operator. A sampling of at least 40 completed welds for a job shall be made for such reduction evaluation. Reject rate is defined as the number of welds containing rejectable defects divided by the number of welds completed. For evaluating the reject rate of continuous welds over 3 feet (914 mm) in length where the effective throat thickness is 1 inch (25.4 mm) or less, each 12-inch increment (305 mm) or fraction thereof shall be considered as one weld. For evaluating the reject rate on continuous welds over 3 feet (914 mm) in length where the effective throat thickness is greater than 1 inch (25.4 mm), each 6 inches (152 mm) of length or fraction thereof shall be considered one weld.

For complete penetration groove welds on materials less than  $\frac{5}{16}$  inch (7.9 mm) thick, nondestructive testing is not required; for this welding, continuous inspection is required.

When approved by the building official and outlined in the project plans and specifications, this nondestructive ultrasonic testing may be performed in the shop of an approved fabricator utilizing qualified test techniques in the employment of the fabricator.

2. Partial penetration groove welds when used in column splices shall be tested either by ultrasonic testing or radiography when required by the plans and specifications. For partial penetration groove welds when used in column splices, with an effective throat less than  $\frac{3}{4}$  inch (19.1 mm) thick, nondestructive testing is not required; for this welding, continuous special inspection is required.

3. Base metal thicker than  $1\frac{1}{2}$  inches (38.1 mm), when subjected to through-thickness weld shrinkage strains, shall be ultrasonically inspected for discontinuities directly behind such welds after joint completion.

Any material discontinuities shall be accepted or rejected on the basis of the defect rating in accordance with the (larger reflector) criteria of approved national standards.

### SECTION 1704 — PREFABRICATED CONSTRUCTION

#### 1704.1 General.

**1704.1.1 Purpose.** The purpose of this section is to regulate materials and establish methods of safe construction where any structure or portion thereof is wholly or partially prefabricated.

**1704.1.2 Scope.** Unless otherwise specifically stated in this section, all prefabricated construction and all materials used therein shall conform to all the requirements of this code. (See Section 104.2.8.)

**1704.1.3 Definition.**

**PREFABRICATED ASSEMBLY** is a structural unit, the integral parts of which have been built up or assembled prior to incorporation in the building.

**1704.2 Tests of Materials.** Every approval of a material not specifically mentioned in this code shall incorporate as a proviso, the kind and number of tests to be made during prefabrication.

**1704.3 Tests of Assemblies.** The building official may require special tests to be made on assemblies to determine their durability and weather resistance.

**1704.4 Connections.** See Section 1612.1 for design requirements of connections for prefabricated assemblies.

**1704.5 Pipes and Conduits.** See Section 1612.2 for design requirements for removal of material for pipes, conduit and other equipment.

**1704.6 Certificate and Inspection.**

**1704.6.1 Materials.** Materials and the assembly thereof shall be inspected to determine compliance with this code. Every material shall be graded, marked or labeled where required elsewhere in this code.

**1704.6.2 Certificate.** A certificate of approval shall be furnished with every prefabricated assembly, except where the assembly is readily accessible to inspection at the site. The certificate of approval shall certify that the assembly in question has been inspected and meets all the requirements of this code. When mechanical equipment is installed so that it cannot be inspected at the site, the certificate of approval shall certify that such equipment complies with the laws applying thereto.

**1704.6.3 Certifying agency.** To be acceptable under this code, every certificate of approval shall be made by an approved agency.

**1704.6.4 Field erection.** Placement of prefabricated assemblies at the building site shall be inspected by the building official to determine compliance with this code.

**1704.6.5 Continuous inspection.** If continuous inspection is required for certain materials where construction takes place on the site, it shall also be required where the same materials are used in prefabricated construction.

**EXCEPTION:** Continuous inspection will not be required during prefabrication if the approved agency certifies to the construction and furnishes evidence of compliance.

## Chapter 18 FOUNDATIONS AND RETAINING WALLS

### Division I—GENERAL

#### SECTION 1801 — SCOPE

**1801.1 General.** This chapter sets forth requirements for excavation and fills for any building or structure and for foundations and retaining structures.

Reference is made to Appendix Chapter 33 for requirements governing excavation, grading and earthwork construction, including fills and embankments.

**1801.2 Standards of Quality.** The standards listed below labeled a "U.B.C. standard" are also listed in Chapter 35, Part II, and are part of this code.

1. **Testing.**

1.1 U.B.C. Standard 18-1, Soils Classification

1.2 U.B.C. Standard 18-2, Expansion Index Test

#### SECTION 1802 — QUALITY AND DESIGN

The quality and design of materials used structurally in excavations, footings and foundations shall conform to the requirements specified in Chapters 16, 19, 21, 22 and 23 of this code.

Excavations and fills shall comply with Chapter 33.

#### SECTION 1803 — SOIL CLASSIFICATION—EXPANSIVE SOIL

**1803.1 General.** For the purposes of this chapter, the definition and classification of soil materials for use in Table 18-I-A shall be according to U.B.C. Standard 18-1.

**1803.2 Expansive Soil.** When the expansive characteristics of a soil are to be determined, the procedures shall be in accordance with U.B.C. Standard 18-2 and the soil shall be classified according to Table 18-I-B. Foundations for structures resting on soils with an expansion index greater than 20, as determined by U.B.C. Standard 18-2, shall require special design consideration. In the event the soil expansion index varies with depth, the weighted index shall be determined according to Table 18-I-C.

#### SECTION 1804 — FOUNDATION INVESTIGATION

**1804.1 General.** The classification of the soil at each building site shall be determined when required by the building official. The building official may require that this determination be made by an engineer or architect licensed by the state to practice as such.

**1804.2 Investigation.** The classification shall be based on observation and any necessary tests of the materials disclosed by borings or excavations made in appropriate locations. Additional studies may be necessary to evaluate soil strength, the effect of moisture variation on soil-bearing capacity, compressibility, liquefaction and expansiveness.

In Seismic Zones 3 and 4, when required by the building official, the potential for seismically induced soil liquefaction and soil instability shall be evaluated as described in Section 1804.5.

**EXCEPTIONS:** 1. The building official may waive this evaluation upon receipt of written opinion of a qualified geotechnical engineer or geologist that liquefaction is not probable.

2. A detached, single-story dwelling of Group R, Division 3 Occupancy with or without attached garages.

3. Group U, Division I Occupancies.
4. Fences.

**1804.3 Reports.** The soil classification and design bearing capacity shall be shown on the plans, unless the foundation conforms to Table 18-I-D. The building official may require submission of a written report of the investigation which shall include, but need not be limited to, the following information:

1. A plot showing the location of all test borings and/or excavations.
2. Descriptions and classifications of the materials encountered.
3. Elevation of the water table, if encountered.
4. Recommendations for foundation type and design criteria, including bearing capacity, provisions to mitigate the effects of expansive soils, provisions to mitigate the effects of liquefaction and soil strength and the effects of adjacent loads.
5. Expected total and differential settlement.

**1804.4 Expansive Soils.** When expansive soils are present, the building official may require that special provisions be made in the foundation design and construction to safeguard against damage due to this expansiveness. The building official may require a special investigation and report to provide these design and construction criteria.

**1804.5 Liquefaction Potential and Soil Strength Loss.** When required by Section 1804.2, the potential for soil liquefaction and soil strength loss during earthquakes shall be evaluated during the geotechnical investigation. The geotechnical report shall assess potential consequences of any liquefaction and soil strength loss, including estimation of differential settlement, lateral movement or reduction in foundation soil-bearing capacity, and discuss mitigating measures. Such measures shall be given consideration in the design of the building and may include, but are not limited to, ground stabilization, selection of appropriate foundation type and depths, selection of appropriate structural systems to accommodate anticipated displacements or any combination of these measures.

The potential for liquefaction and soil strength loss shall be evaluated for a site peak ground acceleration that, as a minimum, conforms to the probability of exceedance specified in Section 1629.2. Peak ground acceleration may be determined based on a site-specific study taking into account soil amplification effects. In the absence of such a study, peak ground acceleration may be assumed equal to the seismic zone factor in Table 16-I.

**1804.6 Adjacent Loads.** Where footings are placed at varying elevations the effect of adjacent loads shall be included in the foundation design.

**1804.7 Drainage.** Provisions shall be made for the control and drainage of surface water around buildings. (See also Section 1806.4.5.)

## SECTION 1805 — ALLOWABLE FOUNDATION AND LATERAL PRESSURES

The allowable foundation and lateral pressures shall not exceed the values set forth in Table 18-I-A unless data to substantiate the use of higher values are submitted. Table 18-I-A may be used for design of foundations on rock or nonexpansive soil for Types II One-hour, II-N and V buildings which do not exceed three stories in height or for structures which have continuous footings having a load of less than 2,000 pounds per lineal foot (29.2 kN/m) and isolated footings with loads of less than 50,000 pounds (222.4 kN).

## SECTION 1806 — FOOTINGS

**1806.1 General.** Footings and foundations shall be constructed of masonry, concrete or treated wood in conformance with Division II and shall extend below the frost line. Footings of concrete

and masonry shall be of solid material. Foundations supporting wood shall extend at least 6 inches (152 mm) above the adjacent finish grade. Footings shall have a minimum depth as indicated in Table 18-I-D unless another depth is recommended by a foundation investigation.

The provisions of this section do not apply to building and foundation systems in those areas subject to scour and water pressure by wind and wave action. Buildings and foundations subject to such loads shall be designed in accordance with approved national standards.

**1806.2 Bearing Walls.** Bearing walls shall be supported on masonry or concrete foundations or piles or other approved foundation system which shall be of sufficient size to support all loads. Where a design is not provided, the minimum foundation requirements for stud bearing walls shall be as set forth in Table 18-I-D.

**EXCEPTIONS:** 1. A one-story wood- or metal-frame building not used for human occupancy and not over 400 square feet (37.2 m<sup>2</sup>) in floor area may be constructed with walls supported on a wood foundation plate when approved by the building official.

2. The support of buildings by posts embedded in earth shall be designed as specified in Section 1806.7. Wood posts or poles embedded in earth shall be pressure treated with an approved preservative. Steel posts or poles shall be protected as specified in Section 1807.9.

**1806.3 Stepped Foundations.** Foundations for all buildings where the surface of the ground slopes more than 1 unit vertical in 10 units horizontal (10% slope) shall be level or shall be stepped so that both top and bottom of such foundation are level.

**1806.4 Footings on or Adjacent to Slopes.**

**1806.4.1 Scope.** The placement of buildings and structures on or adjacent to slopes steeper than 1 unit vertical in 3 units horizontal (33.3% slope) shall be in accordance with this section.

**1806.4.2 Building clearance from ascending slopes.** In general, buildings below slopes shall be set a sufficient distance from the slope to provide protection from slope drainage, erosion and shallow failures. Except as provided for in Section 1806.4.6 and Figure 18-1, the following criteria will be assumed to provide this protection. Where the existing slope is steeper than 1 unit vertical in 1 unit horizontal (100% slope), the toe of the slope shall be assumed to be at the intersection of a horizontal plane drawn from the top of the foundation and a plane drawn tangent to the slope at an angle of 45 degrees to the horizontal. Where a retaining wall is constructed at the toe of the slope, the height of the slope shall be measured from the top of the wall to the top of the slope.

**1806.4.3 Footing setback from descending slope surface.** Footing on or adjacent to slope surfaces shall be founded in firm material with an embedment and setback from the slope surface sufficient to provide vertical and lateral support for the footing without detrimental settlement. Except as provided for in Section 1806.4.6 and Figure 18-1, the following setback is deemed adequate to meet the criteria. Where the slope is steeper than 1 unit vertical in 1 unit horizontal (100% slope), the required setback shall be measured from an imaginary plane 45 degrees to the horizontal, projected upward from the toe of the slope.

**1806.4.4 Pools.** The setback between pools regulated by this code and slopes shall be equal to one half the building footing setback distance required by this section. That portion of the pool wall within a horizontal distance of 7 feet (2134 mm) from the top of the slope shall be capable of supporting the water in the pool without soil support.

**1806.4.5 Foundation elevation.** On graded sites, the top of any exterior foundation shall extend above the elevation of the street gutter at point of discharge or the inlet of an approved drainage device a minimum of 12 inches (305 mm) plus 2 percent. The building official may approve alternate elevations, provided it can be demonstrated that required drainage to the point of discharge and away from the structure is provided at all locations on the site.

**1806.4.6 Alternate setback and clearance.** The building official may approve alternate setbacks and clearances. The building official may require an investigation and recommendation of a quali-

fied engineer to demonstrate that the intent of this section has been satisfied. Such an investigation shall include consideration of material, height of slope, slope gradient, load intensity and erosion characteristics of slope material.

**1806.5 Footing Design.** Except for special provisions of Section 1808 covering the design of piles, all portions of footings shall be designed in accordance with the structural provisions of this code and shall be designed to minimize differential settlement and the effects of expansive soils when present.

Slab-on-grade and mat-type footings for buildings located on expansive soils may be designed in accordance with the provisions of Division III or such other engineering design based on geotechnical recommendation as approved by the building official.

**1806.6 Foundation Plates or Sills.** Foundation plates or sills shall be bolted to the foundation or foundation wall with not less than 1/2-inch (13 mm) nominal diameter steel bolts embedded at least 7 inches (178 mm) into the concrete or masonry and spaced not more than 6 feet (1829 mm) apart. There shall be a minimum of two bolts per piece with one bolt located within 12 inches (305 mm) of each end of each piece. A properly sized nut and washer shall be tightened on each bolt to the plate. Foundation plates and sills shall be the kind of wood specified in Section 2317.4.

**1806.7 Designs Employing Lateral Bearing.**

**1806.7.1 General.** Construction employing posts or poles as columns embedded in earth or embedded in concrete footings in the earth may be used to resist both axial and lateral loads. The depth to resist lateral loads shall be determined by means of the design criteria established herein or other methods approved by the building official.

**1806.7.2 Design criteria.**

**1806.7.2.1 Nonconstrained.** The following formula may be used in determining the depth of embedment required to resist lateral loads where no constraint is provided at the ground surface, such as rigid floor or rigid ground surface pavement.

$$d = \frac{A}{2} \left( 1 + \sqrt{1 + \frac{4.36h}{A}} \right) \quad (6-1)$$

**WHERE:**

$$A = \frac{2.34P}{S_1 b}$$

$b$  = diameter of round post or footing or diagonal dimension of square post or footing, feet (m).

$d$  = depth of embedment in earth in feet (m) but not over 12 feet (3658 mm) for purpose of computing lateral pressure.

$h$  = distance in feet (m) from ground surface to point of application of “ $P$ .”

$P$  = applied lateral force in pounds (kN).

$S_1$  = allowable lateral soil-bearing pressure as set forth in Table 18-I-A based on a depth of one third the depth of embedment (kPa).

$S_3$  = allowable lateral soil-bearing pressure as set forth in Table 18-I-A based on a depth equal to the depth of embedment (kPa).

**1806.7.2.2 Constrained.** The following formula may be used to determine the depth of embedment required to resist lateral loads where constraint is provided at the ground surface, such as a rigid floor or pavement.

$$d^2 = 4.25 \frac{Ph}{S_3 b} \quad (6-2)$$

**1806.7.2.3 Vertical load.** The resistance to vertical loads is determined by the allowable soil-bearing pressure set forth in Table 18-I-A.

**1806.7.3 Backfill.** The backfill in the annular space around columns not embedded in poured footings shall be by one of the following methods:

1. Backfill shall be of concrete with an ultimate strength of 2,000 pounds per square inch (13.79 MPa) at 28 days. The hole shall not be less than 4 inches (102 mm) larger than the diameter of the column at its bottom or 4 inches (102 mm) larger than the diagonal dimension of a square or rectangular column.

2. Backfill shall be of clean sand. The sand shall be thoroughly compacted by tamping in layers not more than 8 inches (203 mm) in depth.

**1806.7.4 Limitations.** The design procedure outlined in this section shall be subject to the following limitations:

The frictional resistance for retaining walls and slabs on silts and clays shall be limited to one half of the normal force imposed on the soil by the weight of the footing or slab.

Posts embedded in earth shall not be used to provide lateral support for structural or nonstructural materials such as plaster, masonry or concrete unless bracing is provided that develops the limited deflection required.

**1806.8 Grillage Footings.** When grillage footings of structural steel shapes are used on soils, they shall be completely embedded in concrete with at least 6 inches (152 mm) on the bottom and at least 4 inches (102 mm) at all other points.

**1806.9 Bleacher Footings.** Footings for open-air seating facilities shall comply with Chapter 18.

**EXCEPTIONS:** Temporary open-air portable bleachers as defined in Section 1021 may be supported upon wood sills or steel plates placed directly upon the ground surface, provided soil pressure does not exceed 1,200 pounds per square foot (57.5 kPa).

## SECTION 1807 PILES — GENERAL REQUIREMENTS

**1807.1 General.** Pile foundations shall be designed and installed on the basis of a foundation investigation as defined in Section 1804 where required by the building official.

The investigation and report provisions of Section 1804 shall be expanded to include, but not be limited to, the following:

1. Recommended pile types and installed capacities.
2. Driving criteria.
3. Installation procedures.
4. Field inspection and reporting procedures (to include procedures for verification of the installed bearing capacity where required).
5. Pile load test requirements.

The use of piles not specifically mentioned in this chapter shall be permitted, subject to the approval of the building official upon submission of acceptable test data, calculations or other information relating to the properties and load-carrying capacities of such piles.

**1807.2 Interconnection.** Individual pile caps and caissons of every structure subjected to seismic forces shall be interconnected by ties. Such ties shall be capable of resisting, in tension or compression, a minimum horizontal force equal to 10 percent of the larger column vertical load.

**EXCEPTION:** Other approved methods may be used where it can be demonstrated that equivalent restraint can be provided.

**1807.3 Determination of Allowable Loads.** The allowable axial and lateral loads on piles shall be determined by an approved formula, by load tests or by a foundation investigation.

**1807.4 Static Load Tests.** When the allowable axial load of a single pile is determined by a load test, one of the following methods shall be used:

**Method 1.** It shall not exceed 50 percent of the yield point under test load. The yield point shall be defined as that point at which an increase in load produces a disproportionate increase in settlement.

**Method 2.** It shall not exceed one half of the load which causes a net settlement, after deducting rebound, of 0.01 inch per ton (0.000565 mm/N) of test load which has been applied for a period of at least 24 hours.

**Method 3.** It shall not exceed one half of that load under which, during a 40-hour period of continuous load application, no additional settlement takes place.

**1807.5 Column Action.** All piles standing unbraced in air, water or material not capable of lateral support, shall conform with the applicable column formula as specified in this code. Such piles driven into firm ground may be considered fixed and laterally supported at 5 feet (1524 mm) below the ground surface and in soft material at 10 feet (3048 mm) below the ground surface unless otherwise prescribed by the building official after a foundation investigation by an approved agency.

**1807.6 Group Action.** Consideration shall be given to the reduction of allowable pile load when piles are placed in groups. Where soil conditions make such load reductions advisable or necessary, the allowable axial load determined for a single pile shall be reduced by any rational method or formula approved by the building official.

**1807.7 Piles in Subsiding Areas.** Where piles are driven through subsiding fills or other subsiding strata and derive support from underlying firmer materials, consideration shall be given to the downward frictional forces which may be imposed on the piles by the subsiding upper strata.

Where the influence of subsiding fills is considered as imposing loads on the pile, the allowable stresses specified in this chapter may be increased if satisfactory substantiating data are submitted.

**1807.8 Jetting.** Jetting shall not be used except where and as specifically permitted by the building official. When used, jetting shall be carried out in such a manner that the carrying capacity of existing piles and structures shall not be impaired. After withdrawal of the jet, piles shall be driven down until the required resistance is obtained.

**1807.9 Protection of Pile Materials.** Where the boring records of site conditions indicate possible deleterious action on pile materials because of soil constituents, changing water levels or other factors, such materials shall be adequately protected by methods or processes approved by the building official. The effectiveness of such methods or processes for the particular purpose shall have been thoroughly established by satisfactory service records or other evidence which demonstrates the effectiveness of such protective measures.

**1807.10 Allowable Loads.** The allowable loads based on soil conditions shall be established in accordance with Section 1807.

**EXCEPTION:** Any uncased cast-in-place pile may be assumed to develop a frictional resistance equal to one sixth of the bearing value of the soil material at minimum depth as set forth in Table 18-1-A but not to exceed 500 pounds per square foot (24 kPa) unless a greater value is allowed by the building official after a soil investigation as specified in Section 1804 is submitted. Frictional resistance and bearing resistance shall not be assumed to act simultaneously unless recommended after a foundation investigation as specified in Section 1804.

**1807.11 Use of Higher Allowable Pile Stresses.** Allowable compressive stresses greater than those specified in Section 1808 shall be permitted when substantiating data justifying such higher stresses are submitted to and approved by the building official. Such substantiating data shall include a foundation investigation including a report in accordance with Section 1807.1 by a soils engineer defined as a civil engineer experienced and knowledgeable in the practice of soils engineering.

## SECTION 1808 — SPECIFIC PILE REQUIREMENTS

### 1808.1 Round Wood Piles.

**1808.1.1 Material.** Except where untreated piles are permitted, wood piles shall be pressure treated. Untreated piles may be used only when it has been established that the cutoff will be below lowest groundwater level assumed to exist during the life of the structure.

**1808.1.2 Allowable stresses.** The allowable unit stresses for round wood piles shall not exceed those set forth in Table 23-I-E.

The allowable values listed in Table 23-I-E for compression parallel to the grain at extreme fiber in bending are based on load sharing as occurs in a pile cluster. For piles which support their own specific load, a safety factor of 1.25 shall be applied to compression parallel to the grain values and 1.30 to extreme fiber in bending values.

### 1808.2 Uncased Cast-in-place Concrete Piles.

**1808.2.1 Material.** Concrete piles cast in place against earth in drilled or bored holes shall be made in such a manner as to ensure the exclusion of any foreign matter and to secure a full-sized shaft. The length of such pile shall be limited to not more than 30 times the average diameter. Concrete shall have a specified compressive strength  $f'_c$  of not less than 2,500 psi (17.24 MPa).

**EXCEPTION:** The length of pile may exceed 30 times the diameter provided the design and installation of the pile foundation is in accordance with an approved investigation report.

**1808.2.2 Allowable stresses.** The allowable compressive stress in the concrete shall not exceed  $0.33f'_c$ . The allowable compressive stress of reinforcement shall not exceed 34 percent of the yield strength of the steel or 25,500 psi (175.7 MPa).

### 1808.3 Metal-cased Concrete Piles.

**1808.3.1 Material.** Concrete used in metal-cased concrete piles shall have a specified compressive strength  $f'_c$  of not less than 2,500 psi (17.24 MPa).

**1808.3.2 Installation.** Every metal casing for a concrete pile shall have a sealed tip with a diameter of not less than 8 inches (203 mm).

Concrete piles cast in place in metal shells shall have shells driven for their full length in contact with the surrounding soil and left permanently in place. The shells shall be sufficiently strong to resist collapse and sufficiently watertight to exclude water and foreign material during the placing of concrete.

Piles shall be driven in such order and with such spacing as to ensure against distortion of or injury to piles already in place. No pile shall be driven within four and one-half average pile diameters of a pile filled with concrete less than 24 hours old unless approved by the building official.

**1808.3.3 Allowable stresses.** Allowable stresses shall not exceed the values specified in Section 1808.2.2, except that the allowable concrete stress may be increased to a maximum value of  $0.40f'_c$  for that portion of the pile meeting the following conditions:

1. The thickness of the metal casing is not less than 0.068 inch (1.73 mm) (No. 14 carbon sheet steel gage).
2. The casing is seamless or is provided with seams of equal strength and is of a configuration which will provide confinement to the cast-in-place concrete.
3. The specified compressive strength  $f'_c$  shall not exceed 5,000 psi (34.47 MPa) and the ratio of steel minimum specified yield strength  $f_y$  to concrete specified compressive strength  $f'_c$  shall not be less than 6.
4. The pile diameter is not greater than 16 inches (406 mm).

**1808.4 Precast Concrete Piles.**

**1808.4.1 Materials.** Precast concrete piles shall have a specified compressive strength  $f'_c$  of not less than 3,000 psi (20.68 MPa), and shall develop a compressive strength of not less than 3,000 psi (20.68 MPa) before driving.

**1808.4.2 Reinforcement ties.** The longitudinal reinforcement in driven precast concrete piles shall be laterally tied with steel ties or wire spirals. Ties and spirals shall not be spaced more than 3 inches apart (76 mm), center to center, for a distance of 2 feet (610 mm) from the ends and not more than 8 inches (203 mm) elsewhere. The gage of ties and spirals shall be as follows:

For piles having a diameter of 16 inches (406 mm) or less, wire shall not be smaller than 0.22 inch (5.6 mm) (No. 5 B.W. gage).

For piles having a diameter of more than 16 inches (406 mm) and less than 20 inches (508 mm), wire shall not be smaller than 0.238 inch (6.0 mm) (No. 4 B.W. gage).

For piles having a diameter of 20 inches (508 mm) and larger, wire shall not be smaller than  $\frac{1}{4}$  inch (6.4 mm) round or 0.259 inch (6.6 mm) (No. 3 B.W. gage).

**1808.4.3 Allowable stresses.** Precast concrete piling shall be designed to resist stresses induced by handling and driving as well as by loads. The allowable stresses shall not exceed the values specified in Section 1808.2.2.

**1808.5 Precast Prestressed Concrete Piles (Pretensioned).**

**1808.5.1 Materials.** Precast prestressed concrete piles shall have a specified compressive strength  $f'_c$  of not less than 5,000 psi (34.48 MPa) and shall develop a compressive strength of not less than 4,000 psi (27.58 MPa) before driving.

**1808.5.2 Reinforcement.** The longitudinal reinforcement shall be high-tensile seven-wire strand. Longitudinal reinforcement shall be laterally tied with steel ties or wire spirals.

Ties or spiral reinforcement shall not be spaced more than 3 inches (76 mm) apart center to center for a distance of 2 feet (610 mm) from the ends and not more than 8 inches (203 mm) elsewhere.

At each end of the pile, the first five ties or spirals shall be spaced 1 inch (25 mm) center to center.

For piles having a diameter of 24 inches (610 mm) or less, wire shall not be smaller than 0.22 inch (5.6 mm) (No. 5 B.W. gage). For piles having a diameter greater than 24 inches (610 mm) but less than 36 inches (914 mm), wire shall not be smaller than 0.238 inch (6.0 mm) (No. 4 B.W. gage). For piles having a diameter greater than 36 inches (914 mm), wire shall not be smaller than  $\frac{1}{4}$  inch (6.4 mm) round or 0.259 inch (6.6 mm) (No. 3 B.W. gage).

**1808.5.3 Allowable stresses.** Precast prestressed piling shall be designed to resist stresses induced by handling and driving as well as by loads. The effective prestress in the pile shall not be less than 400 psi (2.76 MPa) for piles up to 30 feet (9144 mm) in length, 550 psi (3.79 MPa) for piles up to 50 feet (15 240 mm) in length, and 700 psi (4.83 MPa) for piles greater than 50 feet (15 240 mm) in length.

The compressive stress in the concrete due to externally applied load shall not exceed:

$$f_c = 0.33f'_c - 0.27fp_c$$

**WHERE:**

$fp_c$  = effective prestress stress on the gross section.

Effective prestress shall be based on an assumed loss of 30,000 psi (206.85 MPa) in the prestressing steel. The allowable stress in the prestressing steel shall not exceed the values specified in Section 1918.

**1808.6 Structural Steel Piles.**

**1808.6.1 Material.** Structural steel piles, steel pipe piles and fully welded steel piles fabricated from plates shall conform to U.B.C. Standard 22-1 and be identified in accordance with Section 2202.2.

**1808.6.2 Allowable stresses.** The allowable axial stresses shall not exceed 0.35 of the minimum specified yield strength  $F_y$  or 12,600 pounds per square inch (86.88 MPa), whichever is less.

**EXCEPTION:** When justified in accordance with Section 1807.11, the allowable axial stress may be increased above 12,600 psi (86.88 MPa) and  $0.35F_y$ , but shall not exceed  $0.5F_y$ .

**1808.6.3 Minimum dimensions.** Sections of driven H-piles shall comply with the following:

1. The flange projection shall not exceed 14 times the minimum thickness of metal in either the flange or the web, and the flange widths shall not be less than 80 percent of the depth of the section.
2. The nominal depth in the direction of the web shall not be less than 8 inches (203 mm).
3. Flanges and webs shall have a minimum nominal thickness of  $\frac{3}{8}$  inch (9.5 mm).

Sections of driven pipe piles shall have an outside diameter of not less than 10 inches (254 mm) and a minimum thickness of not less than  $\frac{1}{4}$  inch (6.4 mm).

#### **1808.7 Concrete-filled Steel Pipe Piles.**

**1808.7.1 Material.** The concrete-filled steel pipe piles shall conform to U.B.C. Standard 22-1 and shall be identified in accordance with Section 2202.2. The concrete-filled steel pipe piles shall have a specified compressive strength  $f'_c$  of not less than 2,500 psi (17.24 MPa).

**1808.7.2 Allowable stresses.** The allowable axial stresses shall not exceed 0.35 of the minimum specified yield strength  $F_y$  of the steel plus 0.33 of the specified compressive strength  $f'_c$  of concrete, provided  $F_y$  shall not be assumed greater than 36,000 psi (248.22 MPa) for computational purposes.

**EXCEPTION:** When justified in accordance with Section 2807.11, the allowable stresses may be increased to  $0.50 F_y$ .

**1808.7.3 Minimum dimensions.** Driven piles of uniform section shall have a nominal outside diameter of not less than 8 inches (203 mm).

### **SECTION 1809 — FOUNDATION CONSTRUCTION—SEISMIC ZONES 3 AND 4**

**1809.1 General.** In Seismic Zones 3 and 4 the further requirements of this section shall apply to the design and construction of foundations, foundation components and the connection of superstructure elements thereto.

**1809.2 Soil Capacity.** The one-third stress increase allowed by Section 1603.5 may be exceeded for soils for combinations including earthquake when substantiated by geotechnical data. The foundation shall be capable of transmitting the design base shear and overturning forces prescribed in Section 1628 from the structure into the supporting soil. The short-term dynamic nature of the loads may be taken into account in establishing the soil properties.

**1809.3 Superstructure-to-Foundation Connection.** The connection of superstructure elements to the foundation shall be adequate to transmit to the foundation the forces for which the elements were required to be designed.

**1809.4 Foundation-Soil Interface.** For regular buildings, the force  $F_t$  may be omitted when determining the overturning moment to be resisted at the foundation-soil interface.

#### **1809.5 Special Requirements for Piles and Caissons.**

**1809.5.1 General.** Piles, caissons and caps shall be designed according to the provisions of Section 1603, including the effects of lateral displacements. Special detailing requirements as described in Section 1809.5.2 shall apply for a length of piles equal to 120 percent of the flexural length. Flexural length shall be considered as a length of pile from the first point of zero lateral deflection to the underside of the pile cap or grade beam.

**1809.5.2 Steel piles, nonprestressed concrete piles and prestressed concrete piles.**

**1809.5.2.1 Steel piles.** Piles shall conform to width-thickness ratios of stiffened, unstiffened and tubular compression elements as shown in Chapter 22, Division VIII.

**1809.5.2.2 Nonprestressed concrete piles.** Piles shall have transverse reinforcement meeting the requirements of Section 1921.4.

**EXCEPTION:** Transverse reinforcement need not exceed the amount determined by Formula (21-2) in Section 1921.4.4.1 for spiral or circular hoop reinforcement or by Formula (21-4) in Section 1921.4.4.1 for rectangular hoop reinforcement.

**1809.5.2.3 Prestressed concrete piles.** Piles shall have a minimum volumetric ratio of spiral reinforcement no less than 0.021 for 14-inch (356 mm) square and smaller piles, and 0.012 for 24-inch (610 mm) square and larger piles unless a smaller value can be justified by rational analysis. Interpolation may be used between the specified ratios for intermediate sizes.

**TABLE 18-I-A—ALLOWABLE FOUNDATION AND LATERAL PRESSURE**

CLASS OF MATERIALS <sup>1</sup>	ALLOWABLE FOUNDATION PRESSURE (psf) <sup>2</sup>	LATERAL BEARING LBS./SQ./FT./FT. OF DEPTH BELOW NATURAL GRADE <sup>3</sup>	LATERAL SLIDING <sup>4</sup>	
	× 0.0479 for kPa	× 0.157 for kPa per meter	Coefficient <sup>5</sup>	Resistance (psf) <sup>6</sup> × 0.0479 for kPa
1. Massive crystalline bedrock	4,000	1,200	.70	
2. Sedimentary and foliated rock	2,000	400	.35	
3. Sandy gravel and/or gravel (GW and GP)	2,000	200	.35	
4. Sand, silty sand, clayey sand, silty gravel and clayey gravel (SW, SP, SM, SC, GM and GC)	1,500	150	.25	
5. Clay, sandy clay, silty clay and clayey silt (CL, ML, MH and CH)	1,000 <sup>7</sup>	100		130

<sup>1</sup>For soil classifications OL, OH and PT (i.e., organic clays and peat), a foundation investigation shall be required.  
<sup>2</sup>All values of allowable foundation pressure are for footings having a minimum width of 12 inches (305 mm) and a minimum depth of 12 inches (305 mm) into natural grade. Except as in Footnote 7 below, increase of 20 percent allowed for each additional foot (305 mm) of width or depth to a maximum value of three times the designated value.  
<sup>3</sup>May be increased the amount of the designated value for each additional foot (305 mm) of depth to a maximum of 15 times the designated value. Isolated poles for uses such as flagpoles or signs and poles used to support buildings which are not adversely affected by a 1/2-inch (13 mm) motion at ground surface due to short-term lateral loads may be designed using lateral bearing values equal to two times the tabulated values.  
<sup>4</sup>Lateral bearing and lateral sliding resistance may be combined.  
<sup>5</sup>Coefficient to be multiplied by the dead load.  
<sup>6</sup>Lateral sliding resistance value to be multiplied by the contact area. In no case shall the lateral sliding resistance exceed one half the dead load.  
<sup>7</sup>No increase for width is allowed.

**TABLE 18-I-B—CLASSIFICATION OF EXPANSIVE SOIL**

EXPANSION INDEX	POTENTIAL EXPANSION
0-20	Very low
21-50	Low
51-90	Medium
91-130	High
Above 130	Very high

**TABLE 18-I-C—WEIGHTED EXPANSION INDEX<sup>1</sup>**

DEPTH INTERVAL <sup>2</sup>	WEIGHT FACTOR
× 304.8 for mm	
0-1	0.4
1-2	0.3
2-3	0.2
3-4	0.1
Below 4	0

<sup>1</sup>The weighted expansion index for nonuniform soils is determined by multiplying the expansion index for each depth interval by the weight factor for that interval and summing the products.

<sup>2</sup>Depth in feet (305 mm) below the ground surface.

**TABLE 18-I-D—FOUNDATIONS FOR STUD BEARING WALLS—MINIMUM REQUIREMENTS<sup>1, 2, 3</sup>**

NUMBER OF FLOORS SUPPORTED BY THE FOUNDATION <sup>4</sup>	THICKNESS OF FOUNDATION WALL (Inches)		WIDTH OF FOOTING (Inches)	THICKNESS OF FOOTING (Inches)	DEPTH BELOW UNDISTURBED GROUND SURFACE (Inches)
	× 25.4 for mm				
	Concrete	Unit Masonry	× 25.4 for mm		
1	6	6	12	6	12
2	8	8	15	7	18
3	10	10	18	8	24

<sup>1</sup>Where unusual conditions or frost conditions are found, footings and foundations shall be as required in Section 1806.1.

<sup>2</sup>The ground under the floor may be excavated to the elevation of the top of the footing.

<sup>3</sup>Interior stud bearing walls may be supported by isolated footings. The footing width and length shall be twice the width shown in this table and the footings shall be spaced not more than 6 feet (1829 mm) on center.

<sup>4</sup>Foundations may support a roof in addition to the stipulated number of floors. Foundations supporting roofs only shall be as required for supporting one floor.

H/2 but need not exceed 15' (4572 mm) max.

H/3 but need not exceed 40' (12 192 mm) max.

**FIGURE 18-I-1**

**Division II—DESIGN STANDARD FOR TREATED WOOD FOUNDATION SYSTEM**  
**Based on National Forest Products Association, Technical Report No. 7****SECTION 1810 — SCOPE**

The basic design and construction requirements for treated wood foundation systems are set forth in this division. Included are criteria for materials, preservative treatment, soil characteristics, environmental control, design loads and structural design.

**SECTION 1811 — MATERIALS**

**1811.1 Lumber.** Lumber shall be of a species and grade for which allowable unit stresses are set forth in Tables 23-I-A-1, 23-I-A-2, 23-I-A-4 and 23-I-A-5 and shall bear the grade mark of, or have a certificate of inspection issued by, an approved lumber grading or inspection bureau or agency.

**1811.2 Plywood.** All plywood shall be bonded with exterior glue and be grade marked indicating conformance with U.B.C. Standard 23-2 and shall bear the grade mark of an approved plywood inspection agency.

**1811.3 Fasteners in Preservative-treated Wood.** Fasteners in preservative-treated wood shall be approved silicon bronze or copper, stainless steel or hot-dipped zinc-coated steel. Silicon bronze, copper and stainless steel fasteners are acceptable for all ground contact and moisture situations. Hot-dipped zinc-coated nails may be used for basement and crawl space wall construction where polyethylene sheeting is applied to the below-grade portion of the exterior wall and for wood basement floor construction, provided the polyethylene sheeting is placed in accordance with Section 1812.4. In addition, crawl space construction shall be located in soils having good drainage, such as GW, GP, SW, SP, GM and SM types. Other types of steel or metal fasteners shall be permitted only if adequate comparative tests for corrosion resistance, including the effects associated with the wood treating chemicals, indicate an equal or better performance. Zinc-coated fasteners shall be coated after manufacture to their final form, including pointing, heating, threading or twisting, as applicable. Electrogalvanized nails or staples and hot-dipped zinc-coated staples shall not be used.

Framing anchors shall be of hot-dipped zinc-coated A-446 Grade A sheet steel conforming to U.B.C. Standard 22-1.

**1811.4 Gravel, Sand or Crushed Stone for Footings Fill.** Gravel shall be washed and well graded. The maximum size stone shall not exceed  $\frac{3}{4}$  inch (19 mm). Gravel shall be free from organic, clayey or silty soils.

Sand shall be coarse, not smaller than  $\frac{1}{16}$ -inch (1.6 mm) grains and shall be free from organic, clayey or silty soils.

Crushed stone shall have a maximum size of  $\frac{1}{2}$  inch (13 mm).

**1811.5 Polyethylene Sheeting.** Polyethylene sheeting shall conform to requirements approved by the building official.

**1811.6 Sealants.** The materials used to attach the polyethylene sheets to each other or to the plywood shall be capable of adhering to those materials to form a continuous seal.

The material used for caulking joints in plywood sheathing shall be capable of adhering to the wood to provide a moisture seal under the conditions of temperature and moisture content at which it will be applied and used.

**1811.7 Preservative Treatment.** All lumber and plywood required to be preservative treated shall be pressure treated and bear the FDN grade mark. After treatment, each piece of lumber and plywood shall be dried to a moisture content not exceeding 19 percent. Each piece of treated lumber

and plywood shall bear an approved quality mark or that of an approved inspection agency which maintains continuing supervision, testing and inspection over the quality of the product, and shall be identified.

Where FDN lumber is cut or drilled after treatment, the cut surface shall be field treated with the following preservatives by repeated brushing, dipping or soaking until the wood absorbs no more preservative: ammoniacal copper arsenate (ACA), chromated copper arsenate (CCA), fluor chrome arsenate phenol (FCAP), acid copper chromate (ACC), or copper naphthenate.

Copper naphthenate shall be prepared with a solvent conforming to AWWA Standard P5. The preservative concentration shall contain a minimum of 2 percent copper metal. Preparations made by manufacturers of preservatives can also be used.

Waterborne preservatives ACA and CCA, Types A, B and C, shall have a minimum concentration of 3 percent in solution. Waterborne preservatives FCAP and ACC may be used for field treatment of material originally treated with CCA and ACA waterborne preservatives and the concentration of FCAP or ACC shall be a minimum of 5 percent in solution.

All lumber and plywood used in exterior foundation walls (except the upper top plate), all interior bearing wall framing and sheathing posts or other wood supports used in crawl spaces; all sleepers, joists, blocking and plywood subflooring used in basement floors; and all other plates, framing and sheathing in the ground or in direct contact with concrete shall be preservative treated. Where a significant portion of a bottom story wall is above adjacent ground level, such as when a building is situated on sloping terrain, the portion of wall to be considered as foundation wall shall be based on good engineering practice. Some members in such a wall may not require preservative treatment, such as window or door headers or the top plate. As a minimum, all exterior wall framing lumber and plywood sheathing less than 6 inches above finished grade shall be preservative treated.

**1811.8 Soil Characteristics.** Soils are defined herein in accordance with the Unified Soil Classification System (see U.B.C. Standard 18-1). Design properties are provided in Table 18-I-A or by a qualified soils engineer who, by approval of the building official, may assign other values based on soil tests or local experience.

Backfill of CH type (inorganic clays of high plasticity) or other types of expansive soils shall not be compacted dry. Backfill with MH soil types (inorganic silts, micaceous or diatomaceous fine sandy or silty soils, elastic silts) shall be well compacted to prevent surface water infiltration.

Organic soils, OL, OH and P<sub>t</sub> are unsatisfactory for foundations unless specifically approved by the building official after a qualified soils engineer advises on the design of the entire soil-structural system.

## SECTION 1812 — DRAINAGE AND MOISTURE CONTROL

**1812.1 General.** The following sections present requirements to achieve dry and energy-efficient below-grade habitable space that is located above the permanent water table. Floors located below the permanent water table are not permitted unless special moisture control measures are designed by persons qualified in accordance with the authority having jurisdiction. (See Section 1804.7.)

**1812.2 Area Drainage.** Adjacent ground surface shall be sloped away from the structure with a gradient of at least 1/2 inch (13 mm) per foot for a distance of 6 feet (1830 mm) or more. Provisions shall be made for drainage to prevent accumulation of surface water.

**1812.3 Subgrade Drainage.** A porous layer of gravel, crushed stone or sand shall be placed to a minimum thickness of 4 inches (102 mm) under basement floor slabs and all wall footings. For basement construction in MH and CH type soils, the porous layer under footings and slab shall be at least 6 inches (153 mm) thick.

Where there is basement space below grade, a sump shall be provided to drain the porous layer unless the foundation is installed in GW, GP, SW, SP, GM and SM type soils. The sump shall be at

least 24-inch (610 mm) diameter or 20-inch (508 mm) square, shall extend at least 24 inches (610 mm) below the bottom of the basement floor slab and shall be capable of positive gravity or mechanical drainage to remove any accumulated water.

**1812.4 Sheeting and Caulking.** Polyethylene sheeting of 6-mil (0.153 mm) thickness shall be applied over the porous layer. A concrete slab shall be poured over the sheeting or a wood basement floor system shall be constructed on the sheeting. Where wood floors are used, the polyethylene sheeting shall be placed over wood sleepers supporting the floor joists. Sheeting should not extend beneath the wood footing plate.

In basement construction, joints between plywood panels in the foundation walls shall be sealed full length with caulking compound. Any unbacked panel joints shall be caulked at the time the panels are fastened to the framing.

Six-mil-thick (0.153 mm) polyethylene sheeting shall be applied over the below-grade portion of exterior basement walls prior to backfilling, except in GW, GP, SW, SP, GM and SM type soils. Joints in the polyethylene sheeting shall be lapped 6 inches (153 mm) and bonded with a sealant. The top edge of the polyethylene sheeting shall be bonded with a sealant to the plywood sheeting. A treated lumber or plywood strip shall be attached to the wall to cover the top edge of the polyethylene sheeting. The wood strip shall extend at least 2 inches (51 mm) above and 5 inches (127 mm) below finish grade level to protect the polyethylene from exposure to light and from mechanical damage at or near grade. The joint between the strip and the wall shall be caulked full length prior to fastening the strip to the wall. Alternatively, asbestos-cement board, brick, stucco or other covering appropriate to the architectural treatment may be used in place of the wood strip. The polyethylene sheeting shall extend down to the bottom of the wood footing plate, but shall not overlap or extend into the gravel footing.

**1812.5 Perimeter Drainage Control.** The space between the side of a basement excavation and the exterior of a basement wall shall be backfilled for half the height of the excavation with the same material used for footings, except that for basements located in GW, GP, SW, SP, GM and SM type soils, or other sites that are well drained and acceptable to the authority having jurisdiction, the granular fill need not exceed a height of 1 foot (305 mm) above the footing. The top of this granular fill outside basement foundation walls and footings shall be covered with strips of 6-mil-thick (0.153 mm) polyethylene sheeting or Type 30 felt, with adjacent strips lapped to provide for water seepage while preventing excessive infiltration of fine soils. Perforated sheeting or other filter membrane may also be used to control infiltration of fines.

**1812.6 Alternate Drainage System.** If a continuous concrete footing rather than a composite wood and gravel footing is used with the wood foundation in basement construction, the concrete shall be placed over a 4-inch-thick (102 mm) layer of gravel, crushed stone or sand that is arranged to allow drainage of water from the granular backfill outside the footing to the porous layer under the slab. Alternately, drainage across the concrete footing shall be provided by transverse pipes or drain tiles embedded in the concrete every 6 linear feet (1829 mm) around the foundation.

**1812.7 Insulation.** Where insulation is applied between studs in exterior basement walls but the insulation is not flush with the exterior wall sheathing and does not extend down to the bottom plate, blocking shall be installed between the studs at the lower end of the insulation to prevent convection currents.

## SECTION 1813 — DESIGN LOADS

**1813.1 General.** All parts of the wood foundation system shall be designed and constructed to provide safe support for all anticipated loads within the stress limits specified by this code. Design loads shall not be less than those specified in Chapter 16.

Design loads shall include downward forces acting on the wall from dead loads and roof and floor live loads, plus the lateral pressure from soil. Where applicable, the foundation also shall be de-

signed to resist wind, earthquake and other static or dynamic forces. The foundation system shall be designed for the most severe distribution, concentration or combination of design loads deemed proper to act on the structure simultaneously.

**1813.2 Soil Loads.** Lateral pressure of the soil on the wall shall be considered in accordance with Section 1609.2.

## SECTION 1814 — STRUCTURAL DESIGN

**1814.1 General.** Structural design of wood foundations shall be in accordance with established structural engineering and wood design practices as set forth in Chapter 23.

**1814.2 Allowable Stresses.** Allowable unit stresses for lumber and plywood shall be as provided in Section 2304. Design stresses for framing lumber shall be based on use under dry conditions (19 percent maximum moisture content), except that stresses for footing plates and crawl space framing shall be based on use under wet conditions. Design stresses for plywood sheathing shall be based on use under damp (moisture content 16 percent or more) conditions.

**1814.3 Allowable Loads on Fastenings.** Allowable loads for steel nails and framing anchors shall be in accordance with Section 2311. Allowable loads for stainless steel Type 304 or 316, silicon bronze or copper nails shall be developed on a comparable basis to loads allowed for common steel nails. Allowable loads for stainless steel Type 304 or 316, silicon bronze or copper staples or other fasteners shall be in accordance with good engineering practice.

**1814.4 Footing Design.** The treated wood foundation systems incorporate a composite footing consisting of a wood footing plate and a layer of gravel, coarse sand or crushed stone. The wood footing plate distributes the axial design load from the framed wall to the gravel layer which in turn distributes it to the supporting soil.

Soil bearing pressure under the gravel, sand or crushed stone footings shall not exceed the allowable soil bearing values from Table 18-I-A except as permitted by Section 1805.

Footing plate width shall be determined by allowable bearing pressure between the footing plate and the granular part of the footing. Gravel, sand or crushed stone under the footing plate shall be compacted to provide an allowable bearing capacity of 3,000 psf (144 kPa) when required by the design, otherwise an allowable bearing capacity of 2,000 psf (96 kPa) shall be assumed.

When the footing plate is wider than the bottom wall plate, the tension stress perpendicular to grain induced in the bottom face of the footing plate shall not exceed one third the allowable unit shear stress for the footing plate. Use of plywood strips to reinforce the lumber footing plate is acceptable.

Thickness and width of the granular footing shall be determined by allowable bearing pressure between the gravel, sand or crushed stone and the supporting soil, assuming the downward load from the wood footing plate is distributed outward through the gravel, sand or crushed stone footing at an angle of 30 degrees from vertical at each edge of the footing plate. Additionally, the gravel, sand or crushed stone footing shall have a width not less than twice the width and a thickness not less than three-quarters the width of the wood footing plate and shall be confined laterally by backfill, granular fill, undisturbed soil, the foundation wall or other equivalent means.

The bottom of the wood footing plate shall not be above the maximum depth of frost penetration unless the gravel, sand or crushed stone footing extends to the maximum depth of frost penetration and is either connected to positive mechanical or gravity drainage, at or below the frost line, or is installed in GW, GP, SW, SP, GM and SM type soils where the permanent water table is below the frost line. A granular footing connected to a positively drained sump (see Section 1812.3) by a trench filled with gravel, sand or crushed stone, or by an acceptable pipe connection, shall be considered to be drained to the level of the bottom of the sump or the bottom of the connecting trench or pipe, whichever is higher.

Where the bottom of the wood footing plate of a crawl space wall is not below the frost line, the top of the gravel, sand or crushed stone outside the wall shall be covered as required in Section 1812.5 for basement construction to prevent excessive infiltration of fine soils.

Where a wood footing plate is close to finished grade, such as when a deep granular footing is used to reach the frost line, the granular footing shall be protected against surface erosion or mechanical disturbance.

Posts and piers and their footings in basements or crawl spaces shall be in accordance with Sections 1806 and 2317.

Footings under posts or piers may be of treated wood, treated wood and gravel, precast concrete or other approved material.

**1814.5 Foundation Wall Design.** Foundation wall studs shall be designed for stresses due to combined bending moment and axial loading resulting from lateral soil pressure and downward live and dead loads on the foundation wall, and for shear stresses due to lateral soil pressure. Top and bottom wall plates shall be designed for bearing of the studs on the plates. Joints in footing plate and upper top plate shall be staggered at least one stud space from joints in the adjacent plate to provide continuity between wall panels. Framing at openings in wall and floor systems and at other points of concentrated loads shall be designed with adequate capacity for the concentrated loads.

Plywood wall sheathing shall be designed for the shear and bending moment between studs due to soil pressures.

Joints, fastenings and connections in the wood foundation system shall be adequate to transfer all vertical and horizontal forces to the footing or to the applicable floor system. Connections at the top of the foundation wall shall be designed to transfer lateral soil load into the floor assembly. Lateral load at the bottom of a basement wall shall be transferred to the basement floor through bearing of the studs against the floor. Lateral load at the bottom of a crawl space wall shall be resisted by the soil inside the footing.

Foundation walls subject to racking loads due to earthquake, wind or differential soil pressure forces shall be designed with adequate shear strength to resist the most severe racking load or combination of loads, but earthquake and wind forces shall not be assumed to act simultaneously. Where a bottom wall plate of 1-inch (25 mm) nominal thickness has been used, the bottom of the wall shall be considered an unsupported panel edge when determining shear resistance of the wall.

**1814.6 Interior Load-bearing Walls.** Interior load-bearing walls in basements or crawl spaces shall be designed to carry the applicable dead and live loads in accordance with standard engineering practice and the requirements of this code.

**1814.7 Basement Floor Design.** Concrete slab basement floors shall be designed in accordance with requirements of this code but shall not be less than 3½ inches (89 mm) in thickness.

Wood basement floors shall be designed to withstand axial forces and bending moments resulting from lateral soil pressures at the base of the exterior foundation walls and floor and live and dead loads. Floor framing shall be designed to meet joist deflection requirements of this code.

Unless special provision is made to resist sliding caused by unbalanced lateral soil loads, wood basement floors shall be limited to applications where the differential depth of fill on opposing exterior foundation walls is 2 feet (610 mm) or less.

Joists in wood basement floors shall bear tightly against the narrow face of studs in the foundation wall or directly against a band joist which bears on the studs. Plywood subfloor shall be continuous overlapped joists or over butt joints between in-line joists. Where joists are parallel to the wall, sufficient blocking shall be provided between joists to transfer lateral forces from the base of the wall into the floor system.

Where required, resistance to uplift or restraint against buckling shall be provided by interior bearing walls or appropriately designed stub walls anchored in the supporting soil below.

Sleepers, joists, blocking and plywood subflooring used in basement floors shall meet the treatment requirements of Section 1811.7.

**1814.8 Uplift or Overturning.** Design of the structure for uplift or overturning shall be in accordance with the requirements of this code.

**TABLE 18-III-A—DIFFERENTIAL SWELL OCCURRING AT THE PERIMETER OF A SLAB FOR A CENTER LIFT SWELLING CONDITION IN PREDOMINANTLY KAOLINITE CLAY SOIL (30 PERCENT CLAY)**

PERCENT CLAY (%)	DEPTH TO CONSTANT SUCTION (ft.) × 304.8 for mm	CONSTANT SUCTION (pF)	VELOCITY OF MOISTURE FLOW (inches/month) × 25.4 for mm/month	DIFFERENTIAL SWELL (inch)								
				× 25.4 for mm								
				Edge Distance Penetration								
				× 304.8 for mm								
				1 ft.	2 ft.	3 ft.	4 ft.	5 ft.	6 ft.	7 ft.	8 ft.	
30	3	3.2	0.1	0.001	0.001	0.002	0.002	0.003	0.004	0.004	0.005	
			0.3	0.002	0.004	0.006	0.007	0.009	0.011	0.013	0.015	
			0.5	0.003	0.005	0.008	0.011	0.015	0.018	0.021	0.025	
			0.7	0.004	0.008	0.012	0.017	0.021	0.026	0.032	0.038	
			3.4	0.1	0.001	0.002	0.003	0.004	0.006	0.007	0.008	0.009
				0.3	0.004	0.008	0.011	0.015	0.020	0.024	0.029	0.034
				0.5	0.006	0.012	0.019	0.026	0.034	0.044	0.054	0.067
				0.7	0.008	0.017	0.027	0.038	0.052	0.069	0.091	0.124
			3.6	0.1	0.003	0.006	0.009	0.012	0.015	0.019	0.022	0.026
				0.3	0.008	0.017	0.027	0.040	0.055	0.073	0.099	0.137
				0.5	0.014	0.030	0.050	0.077	0.117	0.192	0.370	0.881
				0.7	0.018	0.042	0.074	0.125	0.226	0.487	1.252	3.530
	5	3.2	0.1	0.001	0.003	0.004	0.005	0.007	0.008	0.010	0.012	
			0.3	0.004	0.008	0.012	0.016	0.020	0.025	0.029	0.034	
			0.5	0.007	0.013	0.020	0.028	0.035	0.043	0.051	0.060	
			0.7	0.009	0.019	0.029	0.040	0.051	0.062	0.075	0.089	
			3.4	0.1	0.003	0.005	0.008	0.011	0.014	0.017	0.020	0.023
				0.3	0.008	0.016	0.025	0.034	0.044	0.055	0.066	0.078
				0.5	0.014	0.028	0.043	0.060	0.079	0.100	0.125	0.153
				0.7	0.018	0.039	0.062	0.088	0.119	0.157	0.207	0.279
			3.6	0.1	0.006	0.013	0.020	0.027	0.034	0.042	0.050	0.059
				0.3	0.019	0.040	0.063	0.091	0.123	0.163	0.217	0.300
				0.5	0.030	0.067	0.112	0.171	0.258	0.413	0.776	1.797
				0.7	0.042	0.096	0.166	0.276	0.486	1.009	2.499	6.879
	7	3.2	0.1	0.002	0.004	0.007	0.009	0.012	0.015	0.017	0.020	
			0.3	0.007	0.015	0.022	0.030	0.038	0.046	0.055	0.063	
			0.5	0.012	0.025	0.038	0.051	0.065	0.080	0.095	0.111	
			0.7	0.017	0.035	0.063	0.073	0.093	0.115	0.139	0.164	
			3.4	0.1	0.005	0.010	0.016	0.021	0.026	0.031	0.037	0.042
				0.3	0.015	0.030	0.046	0.063	0.081	0.100	0.121	0.142
				0.5	0.024	0.050	0.079	0.110	0.144	0.184	0.228	0.281
				0.7	0.034	0.071	0.113	0.161	0.218	0.287	0.379	0.514
			3.8	0.1	0.011	0.022	0.033	0.045	0.057	0.069	0.082	0.096
				0.3	0.032	0.066	0.124	0.147	0.197	0.257	0.332	0.436
				0.5	0.051	0.110	0.182	0.272	0.396	0.596	1.006	2.098
				0.7	0.071	0.157	0.269	0.431	0.712	1.346	3.081	8.129

**TABLE 18-III-B—DIFFERENTIAL SWELL OCCURRING AT THE PERIMETER OF A SLAB FOR A CENTER LIFT SWELLING CONDITION IN PREDOMINANTLY KAOLINITE CLAY SOIL (40 PERCENT CLAY)**

PERCENT CLAY (%)	DEPTH TO CONSTANT SUCTION (ft.) × 304.8 for mm	CONSTANT SUCTION (pF)	VELOCITY OF MOISTURE FLOW (inches/month) × 25.4 for mm/month	DIFFERENTIAL SWELL (inch)								
				× 25.4 for mm								
				Edge Distance Penetration								
				× 304.8 for mm								
				1 ft.	2 ft.	3 ft.	4 ft.	5 ft.	6 ft.	7 ft.	8 ft.	
40	3	3.2	0.1	0.001	0.001	0.002	0.002	0.004	0.005	0.006	0.006	0.006
			0.3	0.002	0.004	0.006	0.009	0.011	0.014	0.016	0.019	
			0.5	0.004	0.008	0.012	0.016	0.020	0.024	0.029	0.034	
			0.7	0.005	0.010	0.016	0.022	0.029	0.035	0.043	0.050	
		3.4	0.1	0.002	0.004	0.005	0.007	0.008	0.009	0.011	0.014	0.014
			0.3	0.004	0.009	0.014	0.020	0.025	0.032	0.038	0.044	
			0.5	0.007	0.016	0.024	0.037	0.046	0.058	0.073	0.090	
			0.7	0.011	0.023	0.036	0.051	0.070	0.092	0.122	0.166	
		3.6	0.1	0.003	0.007	0.011	0.015	0.020	0.024	0.029	0.034	0.034
			0.3	0.010	0.023	0.037	0.053	0.072	0.097	0.131	0.183	
			0.5	0.018	0.040	0.066	0.102	0.157	0.256	0.496	1.181	
			0.7	0.025	0.056	0.100	0.168	0.303	0.653	1.677	4.728	
	5	3.2	0.1	0.002	0.004	0.006	0.007	0.009	0.011	0.013	0.015	0.015
			0.3	0.005	0.011	0.016	0.022	0.028	0.033	0.039	0.046	
			0.5	0.009	0.018	0.027	0.037	0.047	0.057	0.068	0.080	
			0.7	0.012	0.025	0.038	0.053	0.067	0.083	0.100	0.118	
		3.4	0.1	0.003	0.007	0.011	0.015	0.019	0.023	0.027	0.031	0.031
			0.3	0.011	0.022	0.034	0.046	0.059	0.073	0.088	0.104	
			0.5	0.018	0.037	0.148	0.081	0.106	0.134	0.167	0.206	
			0.7	0.025	0.052	0.083	0.118	0.159	0.210	0.277	0.374	
		3.6	0.1	0.008	0.017	0.027	0.036	0.046	0.057	0.068	0.079	0.079
			0.3	0.026	0.054	0.085	0.122	0.165	0.219	0.292	0.401	
			0.5	0.041	0.090	0.150	0.229	0.346	0.553	1.040	2.408	
			0.7	0.057	0.128	0.224	0.371	0.652	1.353	3.349	9.215	
	7	3.2	0.1	0.003	0.006	0.010	0.013	0.017	0.020	0.023	0.027	0.027
			0.3	0.010	0.020	0.030	0.040	0.051	0.062	0.073	0.084	
			0.5	0.016	0.033	0.051	0.069	0.087	0.107	0.127	0.148	
			0.7	0.023	0.046	0.071	0.098	0.125	0.155	0.186	0.220	
		3.4	0.1	0.006	0.013	0.020	0.027	0.034	0.041	0.048	0.056	0.056
			0.3	0.020	0.041	0.062	0.085	0.109	0.135	0.162	0.191	
			0.5	0.033	0.069	0.107	0.148	0.194	0.246	0.306	0.377	
			0.7	0.045	0.095	0.152	0.216	0.292	0.385	0.507	0.689	
		3.58	0.1	0.014	0.029	0.044	0.060	0.076	0.093	0.110	0.129	0.129
			0.3	0.042	0.087	0.138	0.196	0.263	0.343	0.444	0.583	
			0.5	0.069	0.148	0.244	0.365	0.531	0.799	1.348	2.791	
			0.7	0.095	0.210	0.360	0.577	0.953	1.803	4.126	—	

**TABLE 18-III-C—DIFFERENTIAL SWELL OCCURRING AT THE PERIMETER OF A SLAB FOR A CENTER LIFT SWELLING CONDITION IN PREDOMINANTLY KAOLINITE CLAY SOIL (50 PERCENT CLAY)**

PERCENT CLAY (%)	DEPTH TO CONSTANT SUCTION (ft.) × 304.8 for mm	CONSTANT SUCTION (pF)	VELOCITY OF MOISTURE FLOW (inches/month) × 25.4 for mm/month	DIFFERENTIAL SWELL (inch)							
				× 25.4 for mm							
				Edge Distance Penetration							
				× 304.8 for mm							
				1 ft.	2 ft.	3 ft.	4 ft.	5 ft.	6 ft.	7 ft.	8 ft.
50	3	3.2	0.1	0.001	0.002	0.002	0.003	0.004	0.005	0.006	0.007
			0.3	0.003	0.005	0.008	0.011	0.014	0.018	0.021	0.024
			0.5	0.004	0.009	0.014	0.019	0.025	0.030	0.036	0.042
			0.7	0.006	0.013	0.020	0.028	0.036	0.044	0.053	0.063
		3.4	0.1	0.002	0.004	0.006	0.008	0.010	0.012	0.015	0.017
			0.3	0.006	0.012	0.018	0.025	0.032	0.040	0.048	0.057
			0.5	0.009	0.020	0.031	0.043	0.057	0.073	0.091	0.113
			0.7	0.013	0.028	0.044	0.064	0.086	0.115	0.153	0.207
		3.6	0.1	0.005	0.009	0.014	0.020	0.025	0.031	0.037	0.044
			0.3	0.014	0.029	0.046	0.067	0.091	0.123	0.165	0.230
			0.5	0.022	0.049	0.083	0.127	0.196	0.321	0.620	1.480
			0.7	0.031	0.070	0.124	0.210	0.380	0.818	2.103	5.926
	5	3.2	0.1	0.002	0.005	0.007	0.009	0.011	0.014	0.016	0.018
			0.3	0.007	0.014	0.020	0.027	0.035	0.042	0.050	0.057
			0.5	0.011	0.022	0.034	0.046	0.059	0.072	0.086	0.100
			0.7	0.015	0.031	0.048	0.066	0.084	0.104	0.125	0.148
		3.4	0.1	0.005	0.009	0.014	0.019	0.024	0.029	0.034	0.039
			0.3	0.013	0.027	0.042	0.058	0.074	0.092	0.110	0.130
			0.5	0.023	0.047	0.073	0.101	0.133	0.168	0.209	0.258
			0.7	0.031	0.066	0.105	0.148	0.200	0.264	0.347	0.469
		3.6	0.1	0.011	0.022	0.033	0.045	0.058	0.071	0.085	0.099
			0.3	0.031	0.066	0.106	0.151	0.206	0.274	0.365	0.502
			0.5	0.051	0.113	0.188	0.288	0.434	0.694	1.303	3.018
			0.7	0.071	0.160	0.281	0.465	0.817	1.696	4.196	—
	7	3.2	0.1	0.004	0.008	0.013	0.017	0.021	0.025	0.030	0.034
			0.3	0.012	0.024	0.037	0.050	0.064	0.077	0.091	0.106
			0.5	0.021	0.042	0.064	0.086	0.110	0.134	0.159	0.186
			0.7	0.028	0.058	0.090	0.122	0.157	0.194	0.233	0.276
		3.4	0.1	0.008	0.017	0.025	0.034	0.043	0.052	0.061	0.070
			0.3	0.025	0.051	0.078	0.107	0.137	0.169	0.203	0.240
			0.5	0.041	0.085	0.133	0.185	0.243	0.308	0.383	0.472
			0.7	0.057	0.120	0.191	0.272	0.366	0.483	0.636	0.864
		3.58	0.1	0.018	0.036	0.055	0.074	0.095	0.116	0.138	0.161
			0.3	0.053	0.111	0.174	0.246	0.330	0.430	0.557	0.732
			0.5	0.086	0.186	0.306	0.457	0.666	1.001	1.690	3.499
			0.7	0.119	0.263	0.452	0.723	1.194	2.260	5.172	—

**TABLE 18-III-D—DIFFERENTIAL SWELL OCCURRING AT THE PERIMETER OF A SLAB FOR A CENTER LIFT SWELLING CONDITION IN PREDOMINANTLY KAOLINITE CLAY SOIL (60 PERCENT CLAY)**

PERCENT CLAY (%)	DEPTH TO CONSTANT SUCTION (ft.) × 304.8 for mm	CONSTANT SUCTION (pF)	VELOCITY OF MOISTURE FLOW (inches/month) × 25.4 for mm/month	DIFFERENTIAL SWELL (inch)							
				× 25.4 for mm							
				Edge Distance Penetration							
				× 304.8 for mm							
				1 ft.	2 ft.	3 ft.	4 ft.	5 ft.	6 ft.	7 ft.	8 ft.
60	3	3.2	0.1	0.001	0.003	0.004	0.005	0.006	0.007	0.008	0.010
			0.3	0.003	0.007	0.010	0.014	0.018	0.021	0.025	0.029
			0.5	0.006	0.012	0.018	0.024	0.030	0.037	0.044	0.052
			0.7	0.008	0.017	0.025	0.034	0.044	0.054	0.065	0.077
		3.4	0.1	0.002	0.005	0.007	0.010	0.012	0.015	0.017	0.020
			0.3	0.007	0.014	0.022	0.030	0.038	0.047	0.057	0.068
			0.5	0.012	0.024	0.038	0.053	0.069	0.088	0.110	0.136
			0.7	0.016	0.033	0.053	0.077	0.104	0.138	0.184	0.249
		3.6	0.1	0.006	0.012	0.018	0.024	0.031	0.038	0.045	0.053
			0.3	0.017	0.035	0.056	0.081	0.110	0.148	0.199	0.278
			0.5	0.026	0.059	0.099	0.154	0.236	0.386	0.745	1.779
			0.7	0.036	0.083	0.149	0.252	0.455	0.983	2.527	7.124
	5	3.2	0.1	0.003	0.005	0.008	0.011	0.014	0.016	0.019	0.022
			0.3	0.008	0.016	0.025	0.033	0.042	0.051	0.060	0.069
			0.5	0.013	0.027	0.041	0.056	0.071	0.087	0.103	0.120
			0.7	0.019	0.038	0.058	0.080	0.102	0.126	0.151	0.178
		3.4	0.1	0.006	0.011	0.017	0.023	0.029	0.034	0.041	0.047
			0.3	0.016	0.033	0.051	0.069	0.089	0.110	0.132	0.156
			0.5	0.028	0.056	0.087	0.122	0.160	0.202	0.252	0.310
			0.7	0.037	0.078	0.125	0.177	0.240	0.316	0.417	0.564
		3.6	0.1	0.013	0.027	0.040	0.055	0.070	0.086	0.102	0.120
			0.3	0.038	0.080	0.077	0.182	0.248	0.329	0.439	0.604
			0.5	0.062	0.135	0.226	0.345	0.521	0.834	1.566	3.628
			0.7	0.086	0.193	0.337	0.559	0.982	2.039	5.049	—
	7	3.2	0.1	0.005	0.010	0.016	0.021	0.026	0.031	0.036	0.041
			0.3	0.015	0.030	0.046	0.061	0.078	0.094	0.111	0.128
			0.5	0.025	0.050	0.077	0.104	0.132	0.161	0.192	0.224
			0.7	0.034	0.070	0.108	0.147	0.189	0.233	0.281	0.332
		3.4	0.1	0.010	0.020	0.030	0.041	0.052	0.062	0.073	0.085
			0.3	0.030	0.061	0.093	0.128	0.164	0.202	0.243	0.287
			0.5	0.050	0.103	0.160	0.223	0.292	0.371	0.461	0.568
			0.7	0.069	0.144	0.229	0.326	0.440	0.580	0.765	1.038
		3.58	0.1	0.021	0.043	0.066	0.089	0.114	0.139	0.166	0.194
			0.3	0.063	0.131	0.208	0.295	0.396	0.516	0.669	0.879
			0.5	0.103	0.223	0.367	0.549	0.800	1.203	2.031	4.205
			0.7	0.142	0.316	0.543	0.870	1.436	2.717	6.217	—

**TABLE 18-III-E—DIFFERENTIAL SWELL OCCURRING AT THE PERIMETER OF A SLAB FOR A CENTER LIFT SWELLING CONDITION IN PREDOMINANTLY KAOLINITE CLAY SOIL (70 PERCENT CLAY)**

PERCENT CLAY (%)	DEPTH TO CONSTANT SUCTION (ft.) × 304.8 for mm	CONSTANT SUCTION (pF)	VELOCITY OF MOISTURE FLOW (Inches/month) × 25.4 for mm/month	DIFFERENTIAL SWELL (inch)							
				× 25.4 for mm							
				Edge Distance Penetration							
				× 304.8 for mm							
				1 ft.	2 ft.	3 ft.	4 ft.	5 ft.	6 ft.	7 ft.	8 ft.
70	3	3.2	0.1	0.001	0.003	0.004	0.005	0.007	0.008	0.010	0.011
			0.3	0.004	0.008	0.012	0.016	0.021	0.025	0.029	0.034
			0.5	0.006	0.013	0.020	0.027	0.035	0.042	0.051	0.060
			0.7	0.010	0.019	0.029	0.040	0.051	0.063	0.076	0.089
		3.4	0.1	0.003	0.005	0.008	0.011	0.014	0.017	0.020	0.023
			0.3	0.008	0.017	0.026	0.035	0.045	0.056	0.067	0.079
			0.5	0.014	0.028	0.044	0.062	0.081	0.103	0.129	0.159
			0.7	0.019	0.039	0.063	0.090	0.122	0.162	0.215	0.292
		3.6	0.1	0.006	0.013	0.020	0.027	0.035	0.043	0.052	0.061
			0.3	0.019	0.041	0.065	0.094	0.128	0.172	0.232	0.324
			0.5	0.032	0.069	0.117	0.180	0.276	0.451	0.871	2.079
			0.7	0.043	0.098	0.174	0.294	0.532	1.148	2.952	8.322
	5	3.2	0.1	0.003	0.006	0.009	0.013	0.016	0.019	0.022	0.026
			0.3	0.010	0.019	0.029	0.039	0.049	0.059	0.070	0.080
			0.5	0.016	0.032	0.048	0.065	0.083	0.101	0.120	0.140
			0.7	0.022	0.044	0.068	0.093	0.119	0.146	0.176	0.208
		3.4	0.1	0.006	0.012	0.019	0.026	0.033	0.039	0.046	0.054
			0.3	0.018	0.038	0.059	0.081	0.104	0.128	0.155	0.183
			0.5	0.031	0.065	0.101	0.141	0.185	0.235	0.293	0.361
			0.7	0.043	0.082	0.146	0.207	0.280	0.370	0.487	0.659
		3.6	0.1	0.015	0.030	0.046	0.063	0.081	0.099	0.119	0.139
			0.3	0.045	0.094	0.149	0.213	0.290	0.385	0.512	0.706
			0.5	0.072	0.158	0.264	0.404	0.609	0.974	1.830	4.239
			0.7	0.100	0.225	0.394	0.653	1.147	2.381	5.893	—
	7	3.2	0.1	0.006	0.011	0.017	0.023	0.029	0.035	0.041	0.047
			0.3	0.018	0.035	0.053	0.072	0.090	0.110	0.129	0.149
			0.5	0.030	0.059	0.090	0.121	0.154	0.188	0.224	0.262
			0.7	0.040	0.082	0.126	0.172	0.221	0.273	0.328	0.388
		3.4	0.1	0.012	0.024	0.036	0.048	0.060	0.073	0.086	0.099
			0.3	0.035	0.071	0.109	0.149	0.192	0.237	0.284	0.336
			0.5	0.057	0.119	0.186	0.260	0.341	0.432	0.538	0.663
			0.7	0.080	0.168	0.267	0.381	0.514	0.678	0.893	1.213
		3.58	0.1	0.025	0.050	0.077	0.104	0.133	0.163	0.194	0.227
			0.3	0.073	0.154	0.244	0.345	0.463	0.604	0.782	1.028
			0.5	0.120	0.260	0.429	0.642	0.935	1.406	2.373	4.913
			0.7	0.166	0.369	0.634	1.016	1.677	3.175	7.263	—

**TABLE 18-III-F—DIFFERENTIAL SWELL OCCURRING AT THE PERIMETER OF A SLAB FOR A CENTER LIFT SWELLING CONDITION IN PREDOMINANTLY ILLITE CLAY SOIL (30 PERCENT CLAY)**

PERCENT CLAY (%)	DEPTH TO CONSTANT SUCTION (ft.) × 304.8 for mm	CONSTANT SUCTION (pF)	VELOCITY OF MOISTURE FLOW (inches/month) × 25.4 for mm/month	DIFFERENTIAL SWELL (inch)							
				× 25.4 for mm							
				Edge Distance Penetration							
				× 304.8 for mm							
				1 ft.	2 ft.	3 ft.	4 ft.	5 ft.	6 ft.	7 ft.	8 ft.
30	3	3.2	0.1	0.002	0.003	0.004	0.005	0.006	0.007	0.008	0.010
			0.3	0.003	0.007	0.010	0.014	0.017	0.021	0.025	0.029
			0.5	0.006	0.012	0.018	0.024	0.030	0.037	0.044	0.051
			0.7	0.008	0.016	0.024	0.033	0.043	0.053	0.064	0.075
		3.4	0.1	0.003	0.005	0.007	0.010	0.012	0.015	0.017	0.020
			0.3	0.007	0.014	0.022	0.030	0.038	0.047	0.057	0.067
			0.5	0.011	0.024	0.037	0.052	0.068	0.087	0.109	0.135
			0.7	0.016	0.034	0.054	0.077	0.104	0.138	0.182	0.248
		3.6	0.1	0.005	0.011	0.017	0.023	0.030	0.037	0.044	0.051
			0.3	0.016	0.035	0.055	0.080	0.109	0.146	0.197	0.274
			0.5	0.027	0.058	0.098	0.152	0.234	0.382	0.737	1.760
			0.7	0.036	0.083	0.147	0.249	0.451	0.973	2.500	7.049
	5	3.2	0.1	0.003	0.006	0.008	0.011	0.014	0.016	0.019	0.022
			0.3	0.008	0.016	0.024	0.032	0.041	0.050	0.059	0.068
			0.5	0.013	0.027	0.041	0.055	0.070	0.086	0.102	0.119
			0.7	0.018	0.037	0.057	0.078	0.100	0.124	0.149	0.176
		3.4	0.1	0.005	0.011	0.016	0.022	0.028	0.034	0.040	0.046
			0.3	0.016	0.033	0.051	0.069	0.089	0.109	0.131	0.155
			0.5	0.027	0.055	0.086	0.120	0.157	0.200	0.248	0.306
			0.7	0.037	0.078	0.124	0.176	0.238	0.319	0.413	0.558
		3.6	0.1	0.012	0.025	0.039	0.053	0.068	0.084	0.100	0.118
			0.3	0.037	0.079	0.126	0.180	0.245	0.326	0.434	0.598
			0.5	0.062	0.134	0.224	0.342	0.516	0.825	1.551	3.591
			0.7	0.084	0.190	0.333	0.553	0.971	2.016	4.991	—
	7	3.2	0.1	0.005	0.010	0.015	0.020	0.025	0.030	0.035	0.041
			0.3	0.015	0.030	0.045	0.061	0.076	0.093	0.109	0.126
			0.5	0.025	0.050	0.076	0.103	0.131	0.160	0.190	0.221
			0.7	0.034	0.070	0.107	0.146	0.187	0.231	0.278	0.329
		3.4	0.1	0.010	0.020	0.030	0.041	0.051	0.062	0.073	0.084
			0.3	0.029	0.060	0.092	0.126	0.162	0.200	0.241	0.284
			0.5	0.048	0.102	0.158	0.221	0.288	0.367	0.456	0.562
			0.7	0.068	0.143	0.227	0.323	0.436	0.574	0.757	1.028
		3.58	0.1	0.021	0.042	0.065	0.088	0.113	0.138	0.164	0.191
			0.3	0.062	0.131	0.207	0.292	0.392	0.511	0.662	0.870
			0.5	0.103	0.221	0.363	0.543	0.792	1.191	2.010	4.162
			0.7	0.141	0.313	0.537	0.861	1.421	2.689	6.153	—

**TABLE 18-III-G—DIFFERENTIAL SWELL OCCURRING AT THE PERIMETER OF A SLAB FOR A CENTER LIFT SWELLING CONDITION IN PREDOMINANTLY ILLITE CLAY SOIL (40 PERCENT CLAY)**

PERCENT CLAY (%)	DEPTH TO CONSTANT SUCTION (ft.) × 304.8 for mm	CONSTANT SUCTION (pF)	VELOCITY OF MOISTURE FLOW (inches/month) × 25.4 for mm/month	DIFFERENTIAL SWELL (inch)								
				× 25.4 for mm								
				Edge Distance Penetration								
				× 304.8 for mm								
				1 ft.	2 ft.	3 ft.	4 ft.	5 ft.	6 ft.	7 ft.	8 ft.	
40	3	3.2	0.1	0.002	0.003	0.005	0.007	0.008	0.010	0.012	0.014	
			0.3	0.005	0.010	0.015	0.020	0.026	0.031	0.037	0.042	
			0.5	0.008	0.016	0.025	0.034	0.043	0.052	0.063	0.073	
			0.7	0.011	0.023	0.035	0.048	0.062	0.076	0.092	0.109	
			3.4	0.1	0.003	0.006	0.010	0.013	0.017	0.020	0.024	0.028
				0.3	0.010	0.021	0.032	0.043	0.055	0.068	0.082	0.098
				0.5	0.017	0.034	0.054	0.075	0.099	0.126	0.157	0.194
				0.7	0.023	0.048	0.077	0.110	0.149	0.198	0.263	0.357
			3.6	0.1	0.008	0.017	0.025	0.034	0.044	0.054	0.064	0.075
				0.3	0.023	0.050	0.080	0.115	0.157	0.211	0.284	0.396
				0.5	0.039	0.085	0.142	0.220	0.338	0.552	1.065	2.542
				0.7	0.053	0.120	0.213	0.360	0.651	1.405	3.611	—
	5	3.2	0.1	0.004	0.007	0.011	0.015	0.019	0.023	0.027	0.031	
				0.3	0.012	0.024	0.035	0.047	0.060	0.072	0.085	0.098
				0.5	0.019	0.039	0.059	0.080	0.101	0.124	0.147	0.172
				0.7	0.026	0.054	0.083	0.113	0.145	0.179	0.215	0.254
		3.4	0.1	0.007	0.015	0.023	0.031	0.040	0.048	0.057	0.065	
			0.3	0.023	0.047	0.073	0.099	0.128	0.157	0.189	0.224	
			0.5	0.039	0.080	0.124	0.173	0.227	0.288	0.358	0.442	
			0.7	0.053	0.112	0.178	0.254	0.343	0.452	0.596	0.805	
		3.6	0.1	0.018	0.037	0.057	0.077	0.099	0.121	0.145	0.170	
			0.3	0.054	0.114	0.182	0.261	0.354	0.471	0.627	0.863	
			0.5	0.089	0.194	0.323	0.494	0.745	1.192	2.239	5.184	
			0.7	0.122	0.275	0.482	0.799	1.403	2.912	7.207	—	
	7	3.2	0.1	0.007	0.014	0.021	0.029	0.036	0.043	0.051	0.058	
				0.3	0.022	0.043	0.065	0.088	0.111	0.134	0.158	0.183
				0.5	0.035	0.072	0.109	0.148	0.188	0.230	0.274	0.320
				0.7	0.049	0.100	0.154	0.210	0.270	0.330	0.401	0.474
		3.4	0.1	0.015	0.030	0.045	0.060	0.075	0.091	0.106	0.122	
			0.3	0.042	0.067	0.134	0.183	0.234	0.289	0.348	0.410	
			0.5	0.070	0.146	0.228	0.318	0.417	0.528	0.657	0.811	
			0.7	0.098	0.207	0.328	0.466	0.629	0.829	1.093	1.484	
		3.58	0.1	0.030	0.062	0.094	0.128	0.163	0.199	0.236	0.277	
			0.3	0.090	0.188	0.298	0.422	0.566	0.738	0.956	1.256	
			0.5	0.147	0.318	0.524	0.784	1.143	1.719	2.902	6.008	
			0.7	0.203	0.451	0.775	1.242	2.051	3.883	8.882	—	

**TABLE 18-III-H—DIFFERENTIAL SWELL OCCURRING AT THE PERIMETER OF A SLAB FOR A CENTER LIFT SWELLING CONDITION IN PREDOMINANTLY ILLITE CLAY SOIL (50 PERCENT CLAY)**

PERCENT CLAY (%)	DEPTH TO CONSTANT SUCTION (ft.) × 304.8 for mm	CONSTANT SUCTION (pF)	VELOCITY OF MOISTURE FLOW (inches/month) × 25.4 for mm/month	DIFFERENTIAL SWELL (inch)							
				× 25.4 for mm							
				Edge Distance Penetration							
				× 304.8 for mm							
				1 ft.	2 ft.	3 ft.	4 ft.	5 ft.	6 ft.	7 ft.	8 ft.
50	3	3.2	0.1	0.002	0.004	0.006	0.008	0.010	0.013	0.015	0.017
			0.3	0.006	0.013	0.019	0.026	0.033	0.040	0.047	0.055
			0.5	0.010	0.021	0.033	0.042	0.056	0.069	0.082	0.096
			0.7	0.014	0.030	0.046	0.063	0.081	0.099	0.120	0.142
		3.4	0.1	0.004	0.009	0.013	0.018	0.022	0.027	0.032	0.037
			0.3	0.013	0.026	0.041	0.056	0.072	0.089	0.107	0.127
			0.5	0.022	0.045	0.070	0.098	0.129	0.164	0.205	0.254
			0.7	0.030	0.063	0.101	0.144	0.196	0.260	0.344	0.467
		3.6	0.1	0.011	0.021	0.033	0.045	0.057	0.070	0.084	0.098
			0.3	0.031	0.065	0.105	0.150	0.206	0.276	0.372	0.518
			0.5	0.050	0.111	0.185	0.287	0.441	0.721	1.391	3.322
			0.7	0.069	0.156	0.278	0.470	0.851	1.836	4.720	—
	5	3.2	0.1	0.005	0.010	0.015	0.020	0.026	0.031	0.036	0.041
			0.3	0.015	0.030	0.046	0.062	0.078	0.094	0.111	0.128
			0.5	0.025	0.051	0.077	0.104	0.133	0.162	0.193	0.225
			0.7	0.035	0.071	0.110	0.148	0.190	0.235	0.282	0.333
		3.4	0.1	0.010	0.021	0.031	0.042	0.053	0.064	0.075	0.086
			0.3	0.031	0.062	0.096	0.131	0.167	0.207	0.248	0.293
			0.5	0.051	0.104	0.163	0.227	0.298	0.377	0.469	0.579
			0.7	0.070	0.147	0.233	0.332	0.449	0.592	0.779	1.054
		3.6	0.1	0.025	0.049	0.075	0.102	0.130	0.160	0.191	0.224
			0.3	0.071	0.150	0.239	0.341	0.463	0.615	0.820	1.129
			0.5	0.116	0.253	0.423	0.646	0.974	1.558	2.927	6.778
			0.7	0.159	0.359	0.629	1.043	1.834	3.807	9.422	—
	7	3.2	0.1	0.009	0.018	0.028	0.037	0.047	0.056	0.066	0.076
			0.3	0.028	0.056	0.085	0.114	0.144	0.175	0.206	0.238
			0.5	0.046	0.094	0.143	0.193	0.246	0.301	0.358	0.418
			0.7	0.064	0.131	0.201	0.275	0.353	0.436	0.524	0.620
		3.4	0.1	0.019	0.038	0.057	0.077	0.097	0.117	0.138	0.159
			0.3	0.055	0.114	0.175	0.239	0.307	0.378	0.455	0.537
			0.5	0.092	0.192	0.299	0.416	0.546	0.692	0.860	1.061
			0.7	0.129	0.271	0.429	0.610	0.823	1.085	1.429	1.940
		3.58	0.1	0.040	0.081	0.123	0.167	0.213	0.261	0.310	0.362
			0.3	0.117	0.246	0.389	0.551	0.739	0.965	1.250	1.642
			0.5	0.193	0.417	0.685	1.026	1.495	2.248	3.795	7.856
			0.7	0.265	0.590	1.013	1.624	2.682	5.075	—	—

**TABLE 18-III-I—DIFFERENTIAL SWELL OCCURRING AT THE PERIMETER OF A SLAB FOR A CENTER LIFT SWELLING CONDITION IN PREDOMINANTLY ILLITE CLAY SOIL (60 PERCENT CLAY)**

PERCENT CLAY (%)	DEPTH TO CONSTANT SUCTION (ft.) × 304.8 for mm	CONSTANT SUCTION (pF)	VELOCITY OF MOISTURE FLOW (inches/month) × 25.4 for mm/month	DIFFERENTIAL SWELL (inch)							
				× 25.4 for mm							
				Edge Distance Penetration							
				× 304.8 for mm							
				1 ft.	2 ft.	3 ft.	4 ft.	5 ft.	6 ft.	7 ft.	8 ft.
60	3	3.2	0.1	0.003	0.006	0.008	0.011	0.014	0.016	0.019	0.022
			0.3	0.008	0.016	0.024	0.033	0.041	0.050	0.059	0.068
			0.5	0.013	0.027	0.040	0.055	0.070	0.085	0.102	0.119
			0.7	0.018	0.037	0.057	0.078	0.100	0.123	0.148	0.176
		3.4	0.1	0.006	0.011	0.017	0.022	0.028	0.034	0.040	0.046
			0.3	0.016	0.033	0.051	0.069	0.089	0.110	0.133	0.157
			0.5	0.027	0.055	0.087	0.121	0.159	0.203	0.253	0.314
			0.7	0.037	0.078	0.124	0.178	0.241	0.320	0.424	0.576
		3.6	0.1	0.013	0.026	0.040	0.055	0.070	0.086	0.103	0.121
			0.3	0.038	0.080	0.129	0.185	0.254	0.340	0.459	0.639
			0.5	0.062	0.136	0.229	0.355	0.544	0.890	1.659	4.104
			0.7	0.085	0.194	0.344	0.582	1.052	2.268	5.831	—
	5	3.2	0.1	0.006	0.012	0.018	0.025	0.031	0.038	0.044	0.050
			0.3	0.018	0.037	0.056	0.075	0.095	0.116	0.137	0.158
			0.5	0.031	0.062	0.095	0.129	0.164	0.200	0.238	0.277
			0.7	0.043	0.088	0.134	0.183	0.235	0.290	0.348	0.411
		3.4	0.1	0.012	0.025	0.038	0.051	0.065	0.078	0.092	0.106
			0.3	0.038	0.077	0.118	0.161	0.206	0.255	0.306	0.361
			0.5	0.062	0.129	0.201	0.280	0.367	0.466	0.579	0.714
			0.7	0.086	0.181	0.288	0.410	0.554	0.730	0.962	1.301
		3.6	0.1	0.030	0.061	0.093	0.126	0.161	0.197	0.236	0.276
			0.3	0.088	0.185	0.295	0.421	0.572	0.761	1.013	1.394
			0.5	0.144	0.313	0.522	0.797	1.203	1.924	3.615	8.371
			0.7	0.197	0.444	0.778	1.289	2.265	4.702	—	—
	7	3.2	0.1	0.012	0.023	0.035	0.047	0.058	0.070	0.082	0.094
			0.3	0.035	0.069	0.105	0.141	0.178	0.216	0.255	0.294
			0.5	0.057	0.116	0.176	0.239	0.304	0.372	0.442	0.516
			0.7	0.079	0.162	0.249	0.340	0.436	0.538	0.647	0.766
		3.4	0.1	0.023	0.047	0.071	0.095	0.120	0.145	0.170	0.196
			0.3	0.069	0.141	0.216	0.294	0.379	0.467	0.562	0.663
			0.5	0.114	0.237	0.369	0.514	0.674	0.855	1.063	1.310
			0.7	0.156	0.333	0.528	0.752	1.015	1.340	1.764	2.395
		3.58	0.1	0.050	0.100	0.153	0.207	0.263	0.322	0.383	0.447
			0.3	0.145	0.304	0.481	0.681	0.912	1.192	1.543	2.028
			0.5	0.238	0.514	0.846	1.266	1.846	2.776	4.687	9.702
			0.7	0.328	0.730	1.252	2.006	3.312	6.268	—	—

**TABLE 18-III-J—DIFFERENTIAL SWELL OCCURRING AT THE PERIMETER OF A SLAB FOR A CENTER LIFT SWELLING CONDITION IN PREDOMINANTLY ILLITE CLAY SOIL (70 PERCENT CLAY)**

PERCENT CLAY (%)	DEPTH TO CONSTANT SUCTION (ft.) × 304.8 for mm	CONSTANT SUCTION (pF)	VELOCITY OF MOISTURE FLOW (Inches/month) × 25.4 for mm/month	DIFFERENTIAL SWELL (inch)							
				× 25.4 for mm							
				Edge Distance Penetration							
				× 304.8 for mm							
				1 ft.	2 ft.	3 ft.	4 ft.	5 ft.	6 ft.	7 ft.	8 ft.
70	3	3.2	0.1	0.003	0.006	0.009	0.013	0.016	0.019	0.022	0.026
			0.3	0.009	0.019	0.028	0.038	0.048	0.059	0.069	0.080
			0.5	0.016	0.032	0.048	0.066	0.083	0.102	0.121	0.141
			0.7	0.021	0.044	0.068	0.092	0.119	0.147	0.177	0.209
		3.4	0.1	0.007	0.013	0.020	0.027	0.034	0.041	0.047	0.055
			0.3	0.019	0.039	0.061	0.083	0.106	0.131	0.158	0.187
			0.5	0.032	0.066	0.103	0.144	0.190	0.242	0.302	0.374
			0.7	0.044	0.093	0.148	0.212	0.287	0.381	0.510	0.686
		3.6	0.1	0.016	0.032	0.049	0.066	0.084	0.103	0.124	0.145
			0.3	0.045	0.095	0.153	0.220	0.302	0.405	0.545	0.761
			0.5	0.074	0.162	0.273	0.423	0.648	1.061	2.047	4.885
			0.7	0.101	0.231	0.409	0.692	1.251	2.700	6.940	—
	5	3.2	0.1	0.008	0.015	0.022	0.030	0.037	0.045	0.035	0.060
			0.3	0.022	0.044	0.067	0.090	0.114	0.138	0.163	0.189
			0.5	0.037	0.074	0.113	0.153	0.195	0.238	0.283	0.330
			0.7	0.051	0.104	0.159	0.218	0.279	0.345	0.414	0.489
		3.4	0.1	0.015	0.030	0.046	0.062	0.077	0.094	0.110	0.127
			0.3	0.044	0.091	0.140	0.191	0.245	0.303	0.364	0.430
			0.5	0.073	0.153	0.239	0.330	0.437	0.554	0.689	0.850
			0.7	0.102	0.215	0.342	0.487	0.659	0.869	1.145	1.548
		3.6	0.1	0.035	0.071	0.109	0.149	0.191	0.234	0.279	0.327
			0.3	0.104	0.219	0.350	0.501	0.680	0.904	1.204	1.659
			0.5	0.170	0.372	0.620	0.948	1.431	2.290	4.302	9.964
			0.7	0.234	0.528	0.925	1.534	2.696	5.597	—	—
	7	3.2	0.1	0.014	0.027	0.041	0.055	0.069	0.083	0.097	0.112
			0.3	0.040	0.082	0.124	0.167	0.212	0.257	0.303	0.350
			0.5	0.068	0.138	0.210	0.284	0.362	0.442	0.526	0.614
			0.7	0.094	0.193	0.296	0.404	0.519	0.640	0.771	0.911
		3.4	0.1	0.028	0.056	0.084	0.113	0.142	0.173	0.202	0.233
			0.3	0.082	0.167	0.257	0.352	0.451	0.556	0.669	0.789
			0.5	0.136	0.282	0.439	0.612	0.803	1.018	1.265	1.560
			0.7	0.188	0.396	0.629	0.895	1.209	1.594	2.100	2.851
		3.58	0.1	0.058	0.118	0.181	0.246	0.313	0.383	0.456	0.532
			0.3	0.173	0.362	0.573	0.812	1.088	1.419	1.838	2.415
			0.5	0.283	0.612	1.007	1.507	2.197	3.304	5.579	11.549
			0.7	0.391	0.869	1.490	2.388	3.943	7.462	—	—

**TABLE 18-III-K—DIFFERENTIAL SWELL OCCURRING AT THE PERIMETER OF A SLAB FOR A CENTER LIFT SWELLING CONDITION IN PREDOMINANTLY MONTMORILLONITE CLAY SOIL (30 PERCENT CLAY)**

PERCENT CLAY (%)	DEPTH TO CONSTANT SUCTION (ft.) × 304.8 for mm	CONSTANT SUCTION (pF)	VELOCITY OF MOISTURE FLOW (inches/month) × 25.4 for mm/month	DIFFERENTIAL SWELL (inch)							
				× 25.4 for mm							
				Edge Distance Penetration							
				× 304.8 for mm							
				1 ft.	2 ft.	3 ft.	4 ft.	5 ft.	6 ft.	7 ft.	8 ft.
30	3	3.2	0.1	0.001	0.003	0.004	0.005	0.007	0.008	0.009	0.011
			0.3	0.004	0.008	0.012	0.016	0.020	0.025	0.030	0.035
			0.5	0.006	0.013	0.020	0.027	0.035	0.043	0.051	0.060
			0.7	0.010	0.019	0.029	0.040	0.051	0.063	0.076	0.089
		3.4	0.1	0.003	0.005	0.008	0.011	0.014	0.017	0.020	0.023
			0.3	0.008	0.017	0.026	0.035	0.045	0.056	0.067	0.079
			0.5	0.014	0.028	0.044	0.062	0.081	0.102	0.128	0.159
			0.7	0.019	0.039	0.063	0.089	0.122	0.162	0.214	0.291
		3.6	0.1	0.006	0.013	0.020	0.027	0.035	0.043	0.052	0.061
			0.3	0.019	0.041	0.065	0.094	0.128	0.172	0.232	0.323
			0.5	0.031	0.069	0.116	0.179	0.275	0.450	0.868	2.073
			0.7	0.043	0.098	0.173	0.294	0.532	1.145	2.945	8.301
	5	3.2	0.1	0.003	0.006	0.010	0.013	0.016	0.019	0.022	0.026
			0.3	0.009	0.018	0.028	0.038	0.048	0.058	0.069	0.079
			0.5	0.016	0.032	0.048	0.065	0.083	0.101	0.120	0.140
			0.7	0.022	0.044	0.068	0.093	0.119	0.147	0.176	0.208
		3.4	0.1	0.006	0.013	0.019	0.026	0.033	0.039	0.046	0.054
			0.3	0.019	0.039	0.060	0.081	0.104	0.129	0.155	0.182
			0.5	0.032	0.065	0.102	0.141	0.186	0.235	0.293	0.361
			0.7	0.043	0.091	0.145	0.207	0.280	0.369	0.486	0.637
		3.6	0.1	0.015	0.030	0.047	0.063	0.081	0.099	0.119	0.139
			0.3	0.045	0.094	0.149	0.213	0.289	0.384	0.512	0.704
			0.5	0.072	0.158	0.264	0.403	0.607	0.972	1.826	2.514
			0.7	0.100	0.224	0.393	0.651	1.144	2.375	5.870	—
	7	3.2	0.1	0.006	0.012	0.017	0.023	0.029	0.035	0.041	0.047
			0.3	0.017	0.035	0.053	0.071	0.090	0.109	0.128	0.148
			0.5	0.029	0.059	0.089	0.121	0.154	0.188	0.223	0.261
			0.7	0.039	0.081	0.125	0.171	0.219	0.271	0.326	0.386
		3.4	0.1	0.012	0.024	0.036	0.048	0.061	0.074	0.086	0.099
			0.3	0.035	0.071	0.109	0.149	0.191	0.236	0.284	0.335
			0.5	0.058	0.120	0.187	0.261	0.342	0.433	0.537	0.662
			0.7	0.081	0.169	0.268	0.381	0.514	0.677	0.892	1.211
		3.58	0.1	0.024	0.050	0.076	0.104	0.132	0.162	0.193	0.225
			0.3	0.073	0.154	0.243	0.344	0.461	0.602	0.780	1.025
			0.5	0.120	0.259	0.427	0.639	0.932	1.402	2.367	4.900
			0.7	0.165	0.368	0.632	1.013	1.672	3.165	7.244	—

**TABLE 18-III-L—DIFFERENTIAL SWELL OCCURRING AT THE PERIMETER OF A SLAB FOR A CENTER LIFT SWELLING CONDITION IN PREDOMINANTLY MONTMORILLONITE CLAY SOIL (40 PERCENT CLAY)**

PERCENT CLAY (%)	DEPTH TO CONSTANT SUCTION (ft.) × 304.8 for mm	CONSTANT SUCTION (pF)	VELOCITY OF MOISTURE FLOW (inches/month) × 25.4 for mm/month	DIFFERENTIAL SWELL (inch)								
				× 25.4 for mm								
				Edge Distance Penetration								
				× 304.8 for mm								
				1 ft.	2 ft.	3 ft.	4 ft.	5 ft.	6 ft.	7 ft.	8 ft.	
40	3	3.2	0.1	0.002	0.004	0.006	0.008	0.010	0.012	0.014	0.016	
			0.3	0.006	0.012	0.018	0.024	0.030	0.036	0.042	0.049	
			0.5	0.009	0.019	0.029	0.040	0.050	0.062	0.074	0.086	
			0.7	0.014	0.027	0.042	0.057	0.074	0.091	0.109	0.129	
			3.4	0.1	0.004	0.008	0.012	0.016	0.021	0.025	0.029	0.034
				0.3	0.011	0.024	0.037	0.050	0.065	0.080	0.097	0.115
				0.5	0.019	0.040	0.063	0.088	0.116	0.148	0.185	0.229
				0.7	0.027	0.057	0.091	0.130	0.177	0.234	0.311	0.422
			3.6	0.1	0.010	0.019	0.030	0.040	0.051	0.063	0.076	0.089
				0.3	0.028	0.059	0.094	0.136	0.186	0.249	0.335	0.468
				0.5	0.046	0.100	0.168	0.260	0.399	0.652	1.258	3.004
				0.7	0.062	0.142	0.251	0.425	0.769	1.660	4.267	7.762
50	5	3.2	0.1	0.004	0.009	0.013	0.018	0.022	0.027	0.032	0.037	
			0.3	0.013	0.027	0.041	0.055	0.069	0.085	0.100	0.115	
			0.5	0.023	0.046	0.069	0.094	0.120	0.147	0.174	0.203	
			0.7	0.032	0.064	0.098	0.134	0.172	0.212	0.255	0.301	
			3.4	0.1	0.010	0.019	0.028	0.038	0.048	0.058	0.068	0.079
				0.3	0.027	0.056	0.086	0.118	0.151	0.186	0.224	0.264
				0.5	0.045	0.094	0.147	0.205	0.269	0.341	0.424	0.522
				0.7	0.063	0.133	0.211	0.300	0.405	0.535	0.704	0.952
			3.6	0.1	0.021	0.044	0.067	0.092	0.117	0.144	0.172	0.201
				0.3	0.064	0.135	0.216	0.308	0.419	0.556	0.741	1.020
				0.5	0.105	0.229	0.382	0.584	0.880	1.408	2.645	6.127
				0.7	0.144	0.325	0.569	0.944	1.658	3.441	8.517	—
60	7	3.2	0.1	0.009	0.018	0.026	0.035	0.043	0.052	0.061	0.070	
			0.3	0.025	0.051	0.077	0.103	0.131	0.158	0.186	0.215	
			0.5	0.042	0.085	0.129	0.175	0.223	0.272	0.324	0.378	
			0.7	0.059	0.119	0.183	0.249	0.320	0.394	0.475	0.561	
			3.4	0.1	0.017	0.035	0.052	0.070	0.088	0.106	0.125	0.144
				0.3	0.050	0.103	0.158	0.216	0.277	0.342	0.411	0.485
				0.5	0.084	0.173	0.270	0.377	0.494	0.626	0.778	0.960
				0.7	0.116	0.244	0.387	0.550	0.743	0.980	1.291	1.753
			3.56	0.1	0.033	0.066	0.101	0.136	0.173	0.211	0.251	0.292
				0.3	0.096	0.201	0.316	0.444	0.590	0.706	0.967	1.231
				0.5	0.158	0.339	0.553	0.815	1.160	1.668	2.583	4.748
				0.7	0.218	0.480	0.813	1.271	2.004	3.504	7.412	—

**TABLE 18-III-M—DIFFERENTIAL SWELL OCCURRING AT THE PERIMETER OF A SLAB FOR A CENTER LIFT SWELLING CONDITION IN PREDOMINANTLY MONTMORILLONITE CLAY SOIL (50 PERCENT CLAY)**

PERCENT CLAY (%)	DEPTH TO CONSTANT SUCTION (ft.) × 304.8 for mm	CONSTANT SUCTION (pF)	VELOCITY OF MOISTURE FLOW (inches/month) × 25.4 for mm/month	DIFFERENTIAL SWELL (inch)								
				× 25.4 for mm								
				Edge Distance Penetration								
				× 304.8 for mm								
				1 ft.	2 ft.	3 ft.	4 ft.	5 ft.	6 ft.	7 ft.	8 ft.	
50	3	3.2	0.1	0.003	0.005	0.008	0.010	0.013	0.016	0.018	0.021	
			0.3	0.007	0.015	0.023	0.031	0.039	0.047	0.055	0.065	
			0.5	0.012	0.026	0.038	0.052	0.066	0.081	0.097	0.113	
			0.7	0.018	0.036	0.055	0.075	0.096	0.119	0.143	0.169	
			3.4	0.1	0.006	0.011	0.016	0.022	0.027	0.033	0.038	0.044
				0.3	0.016	0.032	0.049	0.067	0.086	0.106	0.127	0.151
				0.5	0.026	0.053	0.083	0.116	0.153	0.195	0.243	0.301
				0.7	0.036	0.075	0.119	0.170	0.231	0.307	0.407	0.553
			3.6	0.1	0.012	0.025	0.038	0.052	0.067	0.082	0.099	0.116
				0.3	0.036	0.077	0.123	0.177	0.243	0.326	0.439	0.613
				0.5	0.059	0.131	0.220	0.340	0.522	0.854	1.648	3.935
				0.7	0.082	0.186	0.330	0.558	1.008	2.175	5.590	—
5	5	3.2	0.1	0.006	0.012	0.018	0.024	0.030	0.036	0.042	0.048	
			0.3	0.017	0.035	0.054	0.073	0.092	0.111	0.131	0.151	
			0.5	0.030	0.060	0.091	0.124	0.157	0.192	0.228	0.266	
			0.7	0.041	0.083	0.128	0.175	0.224	0.277	0.333	0.394	
			3.4	0.1	0.012	0.024	0.037	0.049	0.062	0.075	0.089	0.102
				0.3	0.036	0.074	0.113	0.154	0.198	0.244	0.294	0.344
				0.5	0.059	0.123	0.193	0.268	0.352	0.446	0.555	0.684
				0.7	0.083	0.174	0.276	0.393	0.531	0.700	0.923	1.247
			3.6	0.1	0.029	0.058	0.089	0.121	0.154	0.189	0.226	0.264
				0.3	0.084	0.177	0.282	0.404	0.548	0.728	0.970	1.336
				0.5	0.137	0.299	0.500	0.764	1.152	1.844	3.464	8.025
				0.7	0.189	0.426	0.745	1.236	2.712	4.508	—	—
7	7	3.2	0.1	0.011	0.022	0.034	0.044	0.056	0.067	0.078	0.090	
			0.3	0.033	0.067	0.101	0.135	0.171	0.208	0.244	0.282	
			0.5	0.055	0.111	0.169	0.229	0.291	0.356	0.423	0.495	
			0.7	0.076	0.155	0.238	0.326	0.418	0.516	0.621	0.734	
			3.4	0.1	0.023	0.045	0.068	0.091	0.115	0.139	0.163	0.188
				0.3	0.066	0.135	0.208	0.284	0.364	0.449	0.539	0.636
				0.5	0.106	0.226	0.354	0.493	0.646	0.819	1.019	1.256
				0.7	0.152	0.320	0.507	0.721	0.973	1.283	1.692	2.256
			3.56	0.1	0.042	0.087	0.131	0.178	0.226	0.276	0.328	0.382
				0.3	0.126	0.263	0.414	0.583	0.773	0.996	1.266	1.613
				0.5	0.207	0.444	0.724	1.068	1.519	2.185	3.382	6.219
				0.7	0.286	0.629	1.066	1.665	2.625	4.590	—	—

**TABLE 18-III-N—DIFFERENTIAL SWELL OCCURRING AT THE PERIMETER OF A SLAB FOR A CENTER LIFT SWELLING CONDITION IN PREDOMINANTLY MONTMORILLONITE CLAY SOIL (60 PERCENT CLAY)**

PERCENT CLAY (%)	DEPTH TO CONSTANT SUCTION (ft.) × 304.8 for mm	CONSTANT SUCTION (pF)	VELOCITY OF MOISTURE FLOW (inches/month) × 25.4 for mm/month	DIFFERENTIAL SWELL (inch)								
				× 25.4 for mm								
				Edge Distance Penetration								
				× 304.8 for mm								
				1 ft.	2 ft.	3 ft.	4 ft.	5 ft.	6 ft.	7 ft.	8 ft.	
60	3	3.2	0.1	0.003	0.006	0.009	0.013	0.016	0.019	0.022	0.026	
			0.3	0.009	0.019	0.028	0.038	0.048	0.059	0.069	0.080	
			0.5	0.015	0.031	0.048	0.065	0.082	0.101	0.120	0.140	
			0.7	0.022	0.044	0.068	0.092	0.119	0.147	0.176	0.209	
			3.4	0.1	0.006	0.013	0.019	0.026	0.033	0.040	0.047	0.054
				0.3	0.019	0.039	0.060	0.082	0.105	0.130	0.157	0.186
				0.5	0.031	0.065	0.102	0.143	0.189	0.240	0.300	0.372
				0.7	0.044	0.093	0.147	0.211	0.286	0.380	0.503	0.683
			3.6	0.1	0.015	0.031	0.048	0.065	0.083	0.102	0.122	0.144
				0.3	0.044	0.095	0.152	0.219	0.300	0.403	0.543	0.758
				0.5	0.073	0.161	0.272	0.420	0.645	1.056	2.037	4.865
				0.7	0.101	0.229	0.407	0.689	1.246	2.689	6.912	—
5	5	3.2	0.1	0.008	0.015	0.023	0.030	0.038	0.045	0.053	0.060	
			0.3	0.022	0.044	0.067	0.090	0.113	0.138	0.162	0.187	
			0.5	0.037	0.074	0.113	0.153	0.194	0.237	0.282	0.329	
			0.7	0.050	0.103	0.158	0.217	0.278	0.343	0.412	0.487	
			3.4	0.1	0.015	0.030	0.043	0.061	0.077	0.093	0.109	0.126
				0.3	0.045	0.091	0.140	0.191	0.245	0.302	0.363	0.426
				0.5	0.073	0.152	0.237	0.331	0.435	0.551	0.686	0.846
				0.7	0.102	0.214	0.341	0.485	0.655	0.865	1.140	1.541
			3.6	0.1	0.035	0.071	0.109	0.149	0.190	0.233	0.279	0.326
				0.3	0.103	0.219	0.349	0.499	0.678	0.901	1.200	1.652
				0.5	0.169	0.370	0.618	0.945	1.425	2.280	4.284	9.923
				0.7	0.234	0.526	0.922	1.528	2.686	5.574	—	—
7	7	3.2	0.1	0.013	0.027	0.041	0.055	0.069	0.083	0.097	0.111	
			0.3	0.041	0.082	0.125	0.168	0.212	0.256	0.302	0.349	
			0.5	0.068	0.137	0.209	0.283	0.360	0.441	0.524	0.612	
			0.7	0.093	0.191	0.294	0.402	0.516	0.637	0.767	0.907	
			3.4	0.1	0.027	0.055	0.083	0.112	0.142	0.171	0.201	0.232
				0.3	0.082	0.167	0.256	0.351	0.449	0.555	0.666	0.786
				0.5	0.135	0.280	0.438	0.609	0.799	1.013	1.260	1.553
				0.7	0.188	0.395	0.627	0.892	1.204	1.587	2.092	2.840
			3.56	0.1	0.053	0.107	0.163	0.221	0.281	0.342	0.407	0.474
				0.3	0.156	0.326	0.512	0.720	0.957	1.232	1.566	1.994
				0.5	0.256	0.549	0.895	1.320	1.879	2.702	4.182	8.216
				0.7	0.354	0.779	1.317	2.059	3.247	5.677	—	—

**TABLE 18-III-O—DIFFERENTIAL SWELL OCCURRING AT THE PERIMETER OF A SLAB FOR A CENTER LIFT SWELLING CONDITION IN PREDOMINANTLY MONTMORILLONITE CLAY SOIL (70 PERCENT CLAY)**

PERCENT CLAY (%)	DEPTH TO CONSTANT SUCTION (ft.) × 304.8 for mm	CONSTANT SUCTION (pF)	VELOCITY OF MOISTURE FLOW (inches/month) × 25.4 for mm/month	DIFFERENTIAL SWELL (inch)							
				× 25.4 for mm							
				Edge Distance Penetration							
				× 304.8 for mm							
				1 ft.	2 ft.	3 ft.	4 ft.	5 ft.	6 ft.	7 ft.	8 ft.
70	3	3.2	0.1	0.004	0.007	0.011	0.015	0.019	0.023	0.026	0.030
			0.3	0.011	0.022	0.034	0.046	0.057	0.070	0.082	0.095
			0.5	0.018	0.037	0.057	0.077	0.098	0.120	0.143	0.167
			0.7	0.026	0.052	0.082	0.110	0.141	0.174	0.210	0.248
		3.4	0.1	0.007	0.015	0.023	0.031	0.039	0.048	0.056	0.065
			0.3	0.023	0.047	0.072	0.098	0.126	0.156	0.188	0.222
			0.5	0.038	0.078	0.122	0.171	0.225	0.287	0.358	0.443
			0.7	0.052	0.110	0.176	0.251	0.341	0.452	0.600	0.814
		3.6	0.1	0.018	0.037	0.056	0.077	0.098	0.121	0.145	0.171
			0.3	0.054	0.114	0.182	0.262	0.359	0.481	0.648	0.903
			0.5	0.088	0.192	0.324	0.502	0.769	1.258	2.428	5.796
			0.7	0.120	0.273	0.485	0.821	1.485	3.203	8.234	—
	5	3.2	0.1	0.009	0.017	0.026	0.035	0.044	0.053	0.062	0.071
			0.3	0.026	0.053	0.080	0.107	0.135	0.164	0.193	0.223
			0.5	0.044	0.088	0.134	0.182	0.231	0.283	0.336	0.392
			0.7	0.060	0.123	0.189	0.258	0.331	0.409	0.491	0.580
		3.4	0.1	0.018	0.036	0.055	0.073	0.092	0.111	0.131	0.151
			0.3	0.053	0.109	0.167	0.228	0.292	0.360	0.433	0.511
			0.5	0.088	0.182	0.284	0.395	0.519	0.658	0.818	1.008
			0.7	0.121	0.256	0.406	0.578	0.781	1.031	1.358	1.837
		3.6	0.1	0.042	0.086	0.131	0.178	0.227	0.278	0.332	0.389
			0.3	0.123	0.260	0.415	0.594	0.807	1.073	1.429	1.968
			0.5	0.202	0.441	0.737	1.126	1.698	2.717	5.104	11.822
			0.7	0.278	0.627	1.098	1.820	3.199	6.640	—	—
	7	3.2	0.1	0.016	0.032	0.049	0.065	0.082	0.098	0.115	0.132
			0.3	0.048	0.097	0.148	0.199	0.251	0.305	0.359	0.415
			0.5	0.081	0.163	0.249	0.338	0.429	0.525	0.624	0.729
			0.7	0.112	0.229	0.351	0.480	0.616	0.759	0.915	1.081
		3.4	0.1	0.032	0.066	0.099	0.134	0.168	0.204	0.240	0.276
			0.3	0.098	0.199	0.306	0.418	0.536	0.661	0.794	0.937
			0.5	0.162	0.334	0.522	0.727	0.952	1.207	1.501	1.851
			0.7	0.224	0.470	0.747	1.063	1.435	1.891	2.492	3.383
		3.56	0.1	0.063	0.128	0.194	0.263	0.334	0.407	0.484	0.563
			0.3	0.185	0.387	0.609	0.857	1.139	1.468	1.865	2.376
			0.5	0.305	0.655	1.067	1.573	2.239	3.219	4.983	9.162
			0.7	0.421	0.928	1.569	2.453	3.868	6.763	—	—

**TABLE 18-III-P—DIFFERENTIAL SWELL OCCURRING AT THE PERIMETER OF A SLAB FOR AN EDGE LIFT SWELLING CONDITION IN PREDOMINANTLY KAOLINITE CLAY SOIL (30 PERCENT CLAY)**

PERCENT CLAY (%)	DEPTH TO CONSTANT SUCTION (ft.) × 304.8 for mm	CONSTANT SUCTION (pF)	VELOCITY OF MOISTURE FLOW (Inches/month) × 25.4 for mm/month	DIFFERENTIAL SWELL (inch)								
				× 25.4 for mm								
				Edge Distance Penetration								
				× 304.8 for mm								
				1 ft.	2 ft.	3 ft.	4 ft.	5 ft.	6 ft.	7 ft.	8 ft.	
30	3	3.2	0.1	0.001	0.001	0.002	0.002	0.003	0.003	0.004	0.004	
			0.3	0.002	0.003	0.004	0.006	0.007	0.009	0.010	0.012	
			0.5	0.003	0.005	0.007	0.010	0.012	0.014	0.017	0.019	
			0.7	0.004	0.007	0.010	0.013	0.017	0.020	0.023	0.026	
			3.4	0.1	0.001	0.002	0.003	0.004	0.005	0.006	0.007	0.008
				0.3	0.003	0.006	0.009	0.012	0.015	0.018	0.021	0.024
				0.5	0.005	0.010	0.015	0.020	0.025	0.029	0.033	0.037
				0.7	0.007	0.014	0.021	0.027	0.033	0.039	0.045	0.050
			3.6	0.1	0.003	0.005	0.008	0.010	0.013	0.015	0.017	0.020
				0.3	0.008	0.015	0.022	0.029	0.035	0.041	0.047	0.053
				0.5	0.013	0.025	0.035	0.046	0.055	0.064	0.072	0.080
				0.7	0.018	0.034	0.048	0.061	0.073	0.084	0.094	0.104
		3.8	0.1	0.006	0.013	0.018	0.024	0.030	0.035	0.040	0.045	
			0.3	0.019	0.035	0.050	0.064	0.076	0.088	0.099	0.109	
			0.5	0.031	0.056	0.078	0.097	0.114	0.129	0.143	0.156	
			0.7	0.042	0.075	0.102	0.125	0.145	0.164	0.180	0.195	
5	5	3.2	0.1	0.001	0.002	0.003	0.004	0.005	0.007	0.008	0.009	
			0.3	0.003	0.007	0.010	0.013	0.016	0.019	0.022	0.025	
			0.5	0.006	0.011	0.016	0.021	0.027	0.032	0.037	0.041	
			0.7	0.008	0.015	0.022	0.030	0.037	0.044	0.050	0.057	
			3.4	0.1	0.002	0.005	0.007	0.009	0.012	0.014	0.016	0.018
				0.3	0.007	0.014	0.021	0.027	0.034	0.040	0.046	0.053
				0.5	0.012	0.023	0.034	0.045	0.055	0.065	0.075	0.084
				0.7	0.016	0.032	0.047	0.061	0.075	0.089	0.101	0.114
			3.6	0.1	0.006	0.012	0.017	0.023	0.028	0.034	0.039	0.044
				0.3	0.018	0.034	0.050	0.065	0.080	0.094	0.107	0.120
				0.5	0.029	0.056	0.081	0.104	0.126	0.147	0.167	0.186
				0.7	0.041	0.077	0.110	0.141	0.169	0.195	0.220	0.243
		3.8	0.1	0.014	0.028	0.042	0.055	0.067	0.079	0.091	0.102	
			0.3	0.043	0.081	0.116	0.148	0.178	0.205	0.231	0.255	
			0.5	0.072	0.131	0.183	0.228	0.270	0.307	0.342	0.374	
			0.7	0.100	0.178	0.244	0.300	0.350	0.395	0.436	0.474	
7	7	3.2	0.1	0.002	0.004	0.006	0.008	0.009	0.011	0.013	0.015	
			0.3	0.006	0.011	0.017	0.022	0.028	0.033	0.039	0.044	
			0.5	0.010	0.019	0.028	0.037	0.046	0.055	0.064	0.072	
			0.7	0.013	0.026	0.039	0.052	0.064	0.076	0.088	0.099	
			3.4	0.1	0.004	0.008	0.012	0.016	0.020	0.024	0.028	0.032
				0.3	0.012	0.024	0.036	0.048	0.059	0.071	0.082	0.093
				0.5	0.021	0.041	0.060	0.079	0.097	0.115	0.132	0.149
				0.7	0.029	0.056	0.083	0.108	0.133	0.157	0.180	0.202
			3.6	0.1	0.010	0.020	0.030	0.040	0.050	0.059	0.069	0.078
				0.3	0.031	0.061	0.089	0.116	0.142	0.167	0.192	0.215
				0.5	0.052	0.100	0.145	0.187	0.227	0.264	0.300	0.335
				0.7	0.073	0.138	0.198	0.254	0.305	0.353	0.399	0.441
		3.8	0.1	—	—	—	—	—	—	—	—	

**TABLE 18-III-Q—DIFFERENTIAL SWELL OCCURRING AT THE PERIMETER OF A SLAB FOR AN EDGE LIFT SWELLING CONDITION IN PREDOMINANTLY KAOLINITE CLAY SOIL (40 PERCENT CLAY)**

PERCENT CLAY (%)	DEPTH TO CONSTANT SUCTION (ft.) × 304.8 for mm	CONSTANT SUCTION (pF)	VELOCITY OF MOISTURE FLOW (inches/month) × 25.4 for mm/month	DIFFERENTIAL SWELL (inch)							
				× 25.4 for mm							
				Edge Distance Penetration							
				× 304.8 for mm							
				1 ft.	2 ft.	3 ft.	4 ft.	5 ft.	6 ft.	7 ft.	8 ft.
40	3	3.2	0.1	0.001	0.001	0.002	0.003	0.003	0.004	0.005	0.005
			0.3	0.002	0.004	0.006	0.008	0.010	0.012	0.014	0.015
			0.5	0.003	0.007	0.010	0.013	0.016	0.019	0.022	0.025
			0.7	0.006	0.009	0.014	0.018	0.022	0.026	0.030	0.034
		3.4	0.1	0.001	0.003	0.004	0.006	0.007	0.008	0.010	0.011
			0.3	0.004	0.008	0.012	0.016	0.020	0.024	0.028	0.032
			0.5	0.007	0.014	0.020	0.027	0.033	0.039	0.045	0.050
			0.7	0.010	0.019	0.028	0.037	0.045	0.052	0.060	0.067
		3.6	0.1	0.004	0.007	0.010	0.014	0.017	0.020	0.023	0.026
			0.3	0.010	0.020	0.030	0.039	0.047	0.055	0.063	0.071
			0.5	0.017	0.033	0.047	0.061	0.074	0.086	0.097	0.108
			0.7	0.024	0.045	0.064	0.081	0.098	0.112	0.126	0.139
		3.8	0.1	0.009	0.017	0.025	0.032	0.040	0.046	0.053	0.060
			0.3	0.025	0.047	0.067	0.085	0.102	0.118	0.132	0.145
			0.5	0.041	0.075	0.104	0.129	0.152	0.173	0.192	0.209
			0.7	0.056	0.100	0.136	0.167	0.195	0.219	0.241	0.261
	5	3.2	0.1	0.002	0.003	0.004	0.006	0.007	0.009	0.010	0.012
			0.3	0.004	0.009	0.013	0.017	0.022	0.026	0.030	0.034
			0.5	0.007	0.015	0.022	0.029	0.035	0.042	0.049	0.056
			0.7	0.010	0.020	0.030	0.040	0.049	0.058	0.067	0.076
		3.4	0.1	0.003	0.006	0.009	0.012	0.016	0.019	0.022	0.025
			0.3	0.009	0.019	0.028	0.037	0.045	0.054	0.062	0.071
			0.5	0.016	0.031	0.046	0.060	0.074	0.087	0.100	0.113
			0.7	0.022	0.043	0.063	0.082	0.101	0.119	0.136	0.152
		3.6	0.1	0.008	0.016	0.023	0.031	0.038	0.045	0.052	0.059
			0.3	0.023	0.046	0.067	0.087	0.107	0.126	0.144	0.161
			0.5	0.039	0.075	0.108	0.140	0.169	0.197	0.223	0.249
			0.7	0.064	0.103	0.147	0.188	0.226	0.261	0.295	0.326
		3.8	0.1	0.019	0.038	0.056	0.073	0.090	0.106	0.121	0.136
			0.3	0.058	0.109	0.156	0.198	0.238	0.275	0.309	0.342
			0.5	0.096	0.176	0.245	0.306	0.361	0.411	0.458	0.501
			0.7	0.134	0.239	0.326	0.402	0.469	0.529	0.584	0.634
	7	3.2	0.1	0.003	0.005	0.008	0.010	0.013	0.015	0.018	0.020
			0.3	0.008	0.015	0.023	0.030	0.037	0.045	0.052	0.059
			0.5	0.013	0.025	0.038	0.050	0.062	0.074	0.085	0.097
			0.7	0.018	0.035	0.052	0.069	0.085	0.102	0.117	0.133
		3.4	0.1	0.006	0.011	0.016	0.022	0.027	0.032	0.038	0.043
			0.3	0.017	0.033	0.049	0.064	0.080	0.095	0.109	0.124
			0.5	0.028	0.054	0.080	0.105	0.130	0.154	0.177	0.200
			0.7	0.039	0.076	0.111	0.145	0.178	0.210	0.241	0.271
		3.6	0.1	0.014	0.027	0.041	0.054	0.067	0.080	0.092	0.105
			0.3	0.042	0.081	0.119	0.155	0.190	0.224	0.257	0.288
			0.5	0.069	0.134	0.194	0.250	0.304	0.354	0.402	0.448
			0.7	0.098	0.185	0.266	0.340	0.409	0.473	0.534	0.591
		3.8	0.1	—	—	—	—	—	—	—	

**TABLE 18-III-R—DIFFERENTIAL SWELL OCCURRING AT THE PERIMETER OF A SLAB FOR AN EDGE LIFT SWELLING CONDITION IN PREDOMINANTLY KAOLINITE CLAY SOIL (50 PERCENT CLAY)**

PERCENT CLAY (%)	DEPTH TO CONSTANT SUCTION (ft.) × 304.8 for mm	CONSTANT SUCTION (pF)	VELOCITY OF MOISTURE FLOW (inches/month) × 25.4 for mm/month	DIFFERENTIAL SWELL (inch)							
				× 25.4 for mm							
				Edge Distance Penetration							
				× 304.8 for mm							
				1 ft.	2 ft.	3 ft.	4 ft.	5 ft.	6 ft.	7 ft.	8 ft.
50	3	3.2	0.1	0.001	0.002	0.003	0.003	0.004	0.005	0.006	0.007
			0.3	0.003	0.005	0.007	0.010	0.012	0.015	0.017	0.019
			0.5	0.004	0.008	0.012	0.016	0.020	0.024	0.028	0.032
			0.7	0.006	0.012	0.017	0.023	0.028	0.033	0.038	0.043
		3.4	0.1	0.002	0.004	0.005	0.007	0.009	0.011	0.012	0.014
			0.3	0.005	0.011	0.016	0.021	0.025	0.030	0.035	0.040
			0.5	0.009	0.017	0.026	0.034	0.041	0.049	0.056	0.063
			0.7	0.012	0.024	0.035	0.046	0.056	0.066	0.075	0.084
		3.6	0.1	0.004	0.009	0.013	0.017	0.021	0.025	0.029	0.033
			0.3	0.013	0.025	0.037	0.048	0.059	0.069	0.079	0.089
			0.5	0.022	0.042	0.059	0.076	0.092	0.107	0.121	0.135
			0.7	0.030	0.056	0.080	0.102	0.122	0.141	0.158	0.175
		3.8	0.1	0.011	0.021	0.031	0.040	0.050	0.058	0.067	0.075
			0.3	0.032	0.059	0.084	0.107	0.128	0.147	0.165	0.182
			0.5	0.052	0.094	0.130	0.162	0.191	0.217	0.240	0.262
			0.7	0.071	0.126	0.171	0.210	0.244	0.275	0.302	0.328
	5	3.2	0.1	0.002	0.004	0.006	0.007	0.009	0.011	0.013	0.015
			0.3	0.006	0.011	0.016	0.022	0.027	0.032	0.037	0.043
			0.5	0.009	0.018	0.027	0.036	0.044	0.053	0.061	0.070
			0.7	0.013	0.025	0.038	0.050	0.062	0.073	0.084	0.096
		3.4	0.1	0.004	0.008	0.012	0.016	0.019	0.023	0.027	0.031
			0.3	0.012	0.023	0.035	0.046	0.057	0.068	0.078	0.088
			0.5	0.020	0.039	0.057	0.075	0.092	0.109	0.126	0.142
			0.7	0.028	0.054	0.079	0.103	0.126	0.149	0.170	0.191
		3.6	0.1	0.010	0.019	0.029	0.038	0.047	0.056	0.065	0.074
			0.3	0.029	0.057	0.084	0.109	0.134	0.158	0.180	0.202
			0.5	0.049	0.094	0.136	0.175	0.212	0.247	0.280	0.312
			0.7	0.068	0.129	0.185	0.236	0.283	0.328	0.369	0.408
		3.8	0.1	0.024	0.048	0.070	0.092	0.112	0.132	0.152	0.171
			0.3	0.072	0.137	0.195	0.249	0.298	0.344	0.387	0.428
			0.5	0.120	0.220	0.307	0.384	0.453	0.516	0.574	0.628
			0.7	0.168	0.299	0.409	0.504	0.588	0.663	0.732	0.795
	7	3.2	0.1	0.003	0.006	0.010	0.013	0.016	0.019	0.022	0.025
			0.3	0.010	0.019	0.028	0.038	0.047	0.056	0.065	0.074
			0.5	0.016	0.032	0.047	0.062	0.077	0.092	0.107	0.121
			0.7	0.022	0.044	0.066	0.087	0.107	0.127	0.147	0.167
		3.4	0.1	0.007	0.014	0.021	0.027	0.034	0.041	0.047	0.054
			0.3	0.021	0.041	0.061	0.080	0.100	0.119	0.137	0.156
			0.5	0.035	0.068	0.100	0.132	0.163	0.193	0.222	0.250
			0.7	0.048	0.095	0.139	0.182	0.223	0.263	0.302	0.339
		3.6	0.1	0.017	0.034	0.051	0.068	0.084	0.100	0.116	0.131
			0.3	0.052	0.102	0.149	0.195	0.239	0.281	0.322	0.361
			0.5	0.087	0.168	0.243	0.314	0.381	0.444	0.504	0.562
			0.7	0.122	0.232	0.333	0.426	0.512	0.593	0.669	0.741
		3.8	0.1	—	—	—	—	—	—	—	

**TABLE 18-III-S—DIFFERENTIAL SWELL OCCURRING AT THE PERIMETER OF A SLAB FOR AN EDGE LIFT SWELLING CONDITION IN PREDOMINANTLY KAOLINITE CLAY SOIL (60 PERCENT CLAY)**

PERCENT CLAY (%)	DEPTH TO CONSTANT SUCTION (ft.) × 304.8 for mm	CONSTANT SUCTION (pF)	VELOCITY OF MOISTURE FLOW (inches/month) × 25.4 for mm/month	DIFFERENTIAL SWELL (inch)							
				× 25.4 for mm							
				Edge Distance Penetration							
				× 304.8 for mm							
				1 ft.	2 ft.	3 ft.	4 ft.	5 ft.	6 ft.	7 ft.	8 ft.
60	3	3.2	0.1	0.001	0.002	0.003	0.004	0.005	0.006	0.007	0.008
			0.3	0.003	0.006	0.009	0.012	0.015	0.018	0.021	0.023
			0.5	0.005	0.010	0.015	0.020	0.024	0.029	0.033	0.038
			0.7	0.007	0.014	0.021	0.027	0.033	0.040	0.046	0.052
		3.4	0.1	0.002	0.004	0.006	0.009	0.011	0.013	0.015	0.017
			0.3	0.006	0.013	0.019	0.025	0.031	0.036	0.042	0.048
			0.5	0.011	0.021	0.031	0.040	0.049	0.058	0.067	0.076
			0.7	0.015	0.029	0.042	0.055	0.067	0.079	0.090	0.101
		3.6	0.1	0.005	0.011	0.016	0.021	0.025	0.030	0.035	0.040
			0.3	0.016	0.031	0.045	0.058	0.071	0.083	0.095	0.106
			0.5	0.026	0.050	0.071	0.092	0.111	0.129	0.146	0.162
			0.7	0.036	0.068	0.097	0.123	0.147	0.169	0.190	0.210
		3.8	0.1	0.013	0.025	0.037	0.049	0.059	0.070	0.080	0.090
			0.3	0.038	0.071	0.101	0.129	0.154	0.177	0.199	0.219
			0.5	0.062	0.113	0.157	0.195	0.229	0.260	0.289	0.315
			0.7	0.085	0.151	0.205	0.252	0.293	0.330	0.363	0.394
	5	3.2	0.1	0.002	0.004	0.007	0.009	0.011	0.013	0.015	0.017
			0.3	0.007	0.013	0.020	0.026	0.032	0.039	0.045	0.051
			0.5	0.011	0.022	0.033	0.043	0.053	0.064	0.074	0.084
			0.7	0.015	0.031	0.045	0.060	0.074	0.088	0.101	0.115
		3.4	0.1	0.005	0.009	0.014	0.019	0.023	0.028	0.033	0.037
			0.3	0.014	0.028	0.042	0.055	0.068	0.081	0.094	0.106
			0.5	0.024	0.046	0.069	0.090	0.111	0.131	0.151	0.170
			0.7	0.033	0.065	0.095	0.124	0.152	0.179	0.205	0.230
		3.6	0.1	0.012	0.023	0.035	0.046	0.057	0.069	0.079	0.089
			0.3	0.035	0.069	0.101	0.132	0.161	0.189	0.217	0.243
			0.5	0.059	0.113	0.163	0.210	0.255	0.297	0.337	0.375
			0.7	0.082	0.155	0.222	0.284	0.341	0.394	0.444	0.491
		3.8	0.1	0.029	0.057	0.084	0.110	0.135	0.159	0.183	0.206
			0.3	0.087	0.164	0.235	0.299	0.358	0.414	0.466	0.515
			0.5	0.144	0.265	0.369	0.461	0.544	0.620	0.690	0.754
			0.7	0.201	0.360	0.492	0.606	0.707	0.798	0.880	0.956
	7	3.2	0.1	0.004	0.008	0.011	0.015	0.019	0.023	0.027	0.030
			0.3	0.011	0.023	0.034	0.045	0.056	0.067	0.078	0.089
			0.5	0.019	0.038	0.057	0.075	0.093	0.111	0.128	0.146
			0.7	0.027	0.053	0.079	0.104	0.129	0.153	0.177	0.201
		3.4	0.1	0.008	0.017	0.025	0.033	0.041	0.049	0.057	0.065
			0.3	0.025	0.049	0.073	0.097	0.120	0.143	0.165	0.187
			0.5	0.042	0.082	0.121	0.159	0.196	0.232	0.267	0.301
			0.7	0.058	0.114	0.167	0.219	0.268	0.316	0.363	0.408
		3.6	0.1	0.021	0.041	0.061	0.081	0.101	0.120	0.139	0.158
			0.3	0.063	0.122	0.179	0.234	0.287	0.338	0.387	0.434
			0.5	0.105	0.201	0.292	0.377	0.457	0.534	0.606	0.675
			0.7	0.147	0.279	0.400	0.512	0.616	0.713	0.804	0.891
		3.8	0.1	—	—	—	—	—	—	—	

**TABLE 18-III-T—DIFFERENTIAL SWELL OCCURRING AT THE PERIMETER OF A SLAB FOR AN EDGE LIFT SWELLING CONDITION IN PREDOMINANTLY KAOLINITE CLAY SOIL (70 PERCENT CLAY)**

PERCENT CLAY (%)	DEPTH TO CONSTANT SUCTION (ft.) × 304.8 for mm	CONSTANT SUCTION (pF)	VELOCITY OF MOISTURE FLOW (inches/month) × 25.4 for mm/month	DIFFERENTIAL SWELL (inch)								
				× 25.4 for mm								
				Edge Distance Penetration								
				× 304.8 for mm								
				1 ft.	2 ft.	3 ft.	4 ft.	5 ft.	6 ft.	7 ft.	8 ft.	
70	3	3.2	0.1	0.001	0.002	0.004	0.005	0.006	0.007	0.008	0.009	
			0.3	0.004	0.007	0.011	0.014	0.017	0.021	0.024	0.027	
			0.5	0.006	0.012	0.017	0.023	0.028	0.034	0.039	0.044	
			0.7	0.008	0.016	0.024	0.032	0.039	0.046	0.054	0.061	
			3.4	0.1	0.003	0.005	0.007	0.010	0.012	0.015	0.017	0.020
				0.3	0.008	0.015	0.022	0.029	0.036	0.042	0.049	0.056
				0.5	0.012	0.024	0.036	0.047	0.058	0.068	0.078	0.088
				0.7	0.017	0.034	0.049	0.064	0.079	0.092	0.106	0.118
			3.6	0.1	0.006	0.012	0.018	0.024	0.030	0.035	0.041	0.046
				0.3	0.018	0.036	0.052	0.068	0.083	0.097	0.111	0.124
				0.5	0.030	0.058	0.084	0.107	0.130	0.151	0.170	0.189
				0.7	0.042	0.079	0.113	0.143	0.172	0.198	0.222	0.245
		3.8	0.1	0.015	0.030	0.043	0.057	0.069	0.082	0.094	0.105	
			0.3	0.044	0.083	0.119	0.150	0.180	0.207	0.232	0.256	
			0.5	0.072	0.132	0.183	0.228	0.268	0.304	0.338	0.369	
			0.7	0.099	0.176	0.240	0.295	0.343	0.386	0.425	0.460	
5	5	3.2	0.1	0.003	0.005	0.008	0.010	0.013	0.015	0.018	0.020	
			0.3	0.008	0.015	0.023	0.031	0.038	0.045	0.053	0.060	
			0.5	0.013	0.026	0.038	0.050	0.062	0.074	0.086	0.098	
			0.7	0.018	0.036	0.053	0.070	0.086	0.103	0.119	0.134	
			3.4	0.1	0.006	0.011	0.017	0.022	0.027	0.033	0.038	0.043
				0.3	0.017	0.033	0.049	0.064	0.080	0.095	0.110	0.124
				0.5	0.028	0.054	0.080	0.105	0.130	0.153	0.176	0.199
				0.7	0.039	0.075	0.111	0.145	0.177	0.209	0.239	0.268
			3.6	0.1	0.014	0.027	0.041	0.054	0.067	0.079	0.092	0.104
				0.3	0.041	0.080	0.118	0.154	0.188	0.221	0.253	0.284
				0.5	0.068	0.132	0.191	0.246	0.298	0.347	0.393	0.438
				0.7	0.096	0.181	0.259	0.331	0.398	0.460	0.518	0.574
		3.8	0.1	0.034	0.067	0.098	0.128	0.158	0.186	0.213	0.240	
			0.3	0.102	0.192	0.274	0.349	0.419	0.483	0.544	0.601	
			0.5	0.169	0.309	0.431	0.539	0.636	0.724	0.806	0.881	
			0.7	0.235	0.420	0.575	0.708	0.826	0.932	1.028	1.117	
7	7	3.2	0.1	0.005	0.009	0.013	0.018	0.022	0.027	0.031	0.035	
			0.3	0.013	0.027	0.040	0.053	0.066	0.079	0.091	0.104	
			0.5	0.022	0.044	0.066	0.087	0.109	0.129	0.150	0.170	
			0.7	0.031	0.062	0.092	0.121	0.150	0.179	0.207	0.234	
			3.4	0.1	0.010	0.019	0.029	0.038	0.048	0.057	0.066	0.076
				0.3	0.029	0.058	0.086	0.113	0.140	0.167	0.193	0.218
				0.5	0.048	0.095	0.141	0.185	0.228	0.270	0.311	0.351
				0.7	0.068	0.133	0.195	0.256	0.314	0.370	0.424	0.476
			3.6	0.1	0.024	0.048	0.072	0.095	0.115	0.140	0.162	0.184
				0.3	0.073	0.143	0.209	0.274	0.335	0.395	0.452	0.508
				0.5	0.122	0.235	0.341	0.441	0.534	0.623	0.708	0.789
				0.7	0.172	0.326	0.468	0.598	0.719	0.833	0.940	1.041
		3.8	0.1	—	—	—	—	—	—	—	—	

**TABLE 18-III-U—DIFFERENTIAL SWELL OCCURRING AT THE PERIMETER OF A SLAB FOR AN EDGE LIFT SWELLING CONDITION IN PREDOMINANTLY ILLITE CLAY SOIL (30 PERCENT CLAY)**

PERCENT CLAY (%)	DEPTH TO CONSTANT SUCTION (ft.) × 304.8 for mm	CONSTANT SUCTION (pF)	VELOCITY OF MOISTURE FLOW (inches/month) × 25.4 for mm/month	DIFFERENTIAL SWELL (inch)							
				× 25.4 for mm							
				Edge Distance Penetration							
				× 304.8 for mm							
				1 ft.	2 ft.	3 ft.	4 ft.	5 ft.	6 ft.	7 ft.	8 ft.
30	3	3.2	0.1	0.001	0.002	0.003	0.004	0.005	0.006	0.007	0.008
			0.3	0.003	0.006	0.009	0.012	0.015	0.017	0.020	0.023
			0.5	0.006	0.010	0.015	0.019	0.024	0.029	0.333	0.037
			0.7	0.007	0.014	0.020	0.027	0.033	0.039	0.045	0.051
		3.4	0.1	0.002	0.004	0.006	0.008	0.010	0.013	0.015	0.017
			0.3	0.006	0.013	0.019	0.025	0.030	0.036	0.042	0.047
			0.5	0.011	0.021	0.030	0.040	0.049	0.058	0.066	0.075
			0.7	0.015	0.029	0.042	0.054	0.067	0.078	0.089	0.100
		3.6	0.1	0.005	0.010	0.015	0.020	0.025	0.030	0.035	0.039
			0.3	0.016	0.030	0.044	0.057	0.070	0.082	0.094	0.105
			0.5	0.026	0.049	0.071	0.091	0.110	0.128	0.144	0.160
			0.7	0.036	0.067	0.096	0.121	0.145	0.168	0.186	0.208
		3.8	0.1	0.013	0.025	0.037	0.048	0.059	0.069	0.079	0.089
			0.3	0.038	0.071	0.100	0.127	0.152	0.175	0.197	0.217
			0.5	0.061	0.112	0.155	0.193	0.227	0.258	0.286	0.312
			0.7	0.084	0.149	0.203	0.250	0.290	0.327	0.360	0.390
	5	3.2	0.1	0.002	0.004	0.007	0.009	0.011	0.013	0.015	0.017
			0.3	0.007	0.013	0.019	0.026	0.032	0.038	0.045	0.051
			0.5	0.011	0.022	0.032	0.043	0.053	0.063	0.073	0.083
			0.7	0.015	0.030	0.045	0.059	0.073	0.087	0.100	0.114
		3.4	0.1	0.005	0.009	0.014	0.019	0.023	0.028	0.032	0.037
			0.3	0.014	0.028	0.041	0.055	0.068	0.080	0.093	0.105
			0.5	0.023	0.046	0.068	0.089	0.110	0.130	0.149	0.168
			0.7	0.033	0.064	0.094	0.123	0.150	0.177	0.202	0.227
		3.6	0.1	0.012	0.023	0.034	0.046	0.056	0.067	0.078	0.088
			0.3	0.035	0.068	0.100	0.130	0.159	0.187	0.214	0.241
			0.5	0.058	0.112	0.161	0.208	0.252	0.294	0.333	0.371
			0.7	0.081	0.154	0.220	0.281	0.337	0.390	0.439	0.486
		3.8	0.1	0.029	0.057	0.083	0.109	0.134	0.158	0.181	0.203
			0.3	0.086	0.163	0.232	0.296	0.355	0.409	0.461	0.509
			0.5	0.143	0.262	0.365	0.456	0.539	0.613	0.683	0.746
			0.7	0.199	0.356	0.487	0.600	0.699	0.789	0.871	0.946
	7	3.2	0.1	0.004	0.008	0.011	0.015	0.019	0.023	0.026	0.030
			0.3	0.011	0.023	0.034	0.045	0.056	0.067	0.077	0.088
			0.5	0.019	0.038	0.056	0.074	0.092	0.110	0.127	0.144
			0.7	0.027	0.052	0.078	0.103	0.127	0.152	0.176	0.198
		3.4	0.1	0.008	0.016	0.024	0.032	0.040	0.048	0.056	0.064
			0.3	0.025	0.049	0.072	0.096	0.119	0.141	0.163	0.185
			0.5	0.041	0.081	0.119	0.157	0.194	0.229	0.264	0.298
			0.7	0.058	0.113	0.166	0.217	0.266	0.313	0.359	0.404
		3.6	0.1	0.021	0.041	0.061	0.080	0.100	0.119	0.137	0.156
			0.3	0.062	0.121	0.177	0.232	0.284	0.334	0.383	0.430
			0.5	0.103	0.199	0.289	0.373	0.453	0.528	0.600	0.668
			0.7	0.145	0.276	0.396	0.507	0.609	0.706	0.796	0.882
		3.8	0.1	—	—	—	—	—	—	—	

**TABLE 18-III-V—DIFFERENTIAL SWELL OCCURRING AT THE PERIMETER OF A SLAB FOR AN EDGE LIFT SWELLING CONDITION IN PREDOMINANTLY ILLITE CLAY SOIL (40 PERCENT CLAY)**

PERCENT CLAY (%)	DEPTH TO CONSTANT SUCTION (ft.) × 304.8 for mm	CONSTANT SUCTION (pF)	VELOCITY OF MOISTURE FLOW (Inches/month) × 25.4 for mm/month	DIFFERENTIAL SWELL (Inch)							
				× 25.4 for mm							
				Edge Distance Penetration							
				× 304.8 for mm							
				1 ft.	2 ft.	3 ft.	4 ft.	5 ft.	6 ft.	7 ft.	8 ft.
40	3	3.2	0.1	0.001	0.003	0.004	0.006	0.007	0.009	0.010	0.011
			0.3	0.004	0.009	0.013	0.017	0.021	0.025	0.029	0.033
			0.5	0.007	0.014	0.021	0.028	0.035	0.041	0.048	0.054
			0.7	0.010	0.020	0.029	0.039	0.048	0.057	0.065	0.074
		3.4	0.1	0.003	0.006	0.009	0.012	0.015	0.018	0.021	0.024
			0.3	0.009	0.018	0.027	0.035	0.044	0.052	0.060	0.068
			0.5	0.015	0.030	0.044	0.058	0.071	0.083	0.096	0.108
			0.7	0.021	0.041	0.060	0.079	0.096	0.113	0.129	0.145
		3.6	0.1	0.008	0.015	0.022	0.029	0.036	0.043	0.050	0.057
			0.3	0.022	0.044	0.064	0.083	0.101	0.119	0.136	0.152
			0.5	0.037	0.071	0.102	0.131	0.158	0.184	0.208	0.231
			0.7	0.051	0.097	0.138	0.175	0.210	0.242	0.272	0.300
		3.8	0.1	0.019	0.036	0.053	0.069	0.085	0.100	0.115	0.129
			0.3	0.054	0.102	0.145	0.184	0.220	0.253	0.284	0.313
			0.5	0.088	0.161	0.224	0.278	0.328	0.372	0.413	0.451
			0.7	0.122	0.216	0.294	0.360	0.419	0.472	0.519	0.563
	5	3.2	0.1	0.003	0.006	0.009	0.013	0.016	0.019	0.022	0.025
			0.3	0.009	0.019	0.028	0.037	0.046	0.055	0.064	0.073
			0.5	0.016	0.031	0.047	0.062	0.076	0.091	0.105	0.120
			0.7	0.022	0.044	0.065	0.085	0.106	0.125	0.145	0.164
		3.4	0.1	0.007	0.014	0.020	0.027	0.033	0.040	0.046	0.053
			0.3	0.020	0.040	0.060	0.079	0.097	0.116	0.134	0.152
			0.5	0.034	0.066	0.098	0.129	0.158	0.187	0.216	0.243
			0.7	0.047	0.092	0.135	0.177	0.217	0.255	0.292	0.328
		3.6	0.1	0.017	0.033	0.050	0.066	0.081	0.097	0.112	0.127
			0.3	0.050	0.098	0.144	0.188	0.230	0.271	0.310	0.347
			0.5	0.084	0.161	0.233	0.300	0.364	0.424	0.481	0.535
			0.7	0.117	0.222	0.317	0.405	0.487	0.563	0.634	0.701
		3.8	0.1	0.042	0.082	0.120	0.157	0.193	0.228	0.261	0.294
			0.3	0.124	0.235	0.335	0.427	0.512	0.591	0.665	0.735
			0.5	0.206	0.378	0.527	0.659	0.777	0.886	0.985	1.078
			0.7	0.288	0.514	0.703	0.866	1.010	1.139	1.257	1.366
	7	3.2	0.1	0.005	0.011	0.016	0.022	0.027	0.033	0.038	0.043
			0.3	0.016	0.033	0.049	0.065	0.080	0.096	0.112	0.127
			0.5	0.027	0.054	0.081	0.107	0.133	0.158	0.183	0.208
			0.7	0.038	0.076	0.112	0.149	0.184	0.219	0.253	0.286
		3.4	0.1	0.012	0.024	0.035	0.047	0.058	0.070	0.081	0.093
			0.3	0.036	0.070	0.105	0.138	0.171	0.204	0.236	0.267
			0.5	0.059	0.117	0.172	0.227	0.279	0.331	0.381	0.430
			0.7	0.083	0.163	0.239	0.313	0.384	0.452	0.518	0.583
		3.6	0.1	0.030	0.059	0.088	0.116	0.144	0.171	0.198	0.225
			0.3	0.089	0.175	0.256	0.335	0.410	0.483	0.553	0.621
			0.5	0.149	0.288	0.417	0.539	0.654	0.762	0.866	0.965
			0.7	0.210	0.399	0.572	0.731	0.880	1.019	1.149	1.273
		3.8	0.1	—	—	—	—	—	—	—	

**TABLE 18-III-W—DIFFERENTIAL SWELL OCCURRING AT THE PERIMETER OF A SLAB FOR AN EDGE LIFT SWELLING CONDITION IN PREDOMINANTLY ILLITE CLAY SOIL (50 PERCENT CLAY)**

PERCENT CLAY (%)	DEPTH TO CONSTANT SUCTION (ft.) × 304.8 for mm	CONSTANT SUCTION (pF)	VELOCITY OF MOISTURE FLOW (inches/month) × 25.4 for mm/month	DIFFERENTIAL SWELL (inch)								
				× 25.4 for mm								
				Edge Distance Penetration								
				× 304.8 for mm								
				1 ft.	2 ft.	3 ft.	4 ft.	5 ft.	6 ft.	7 ft.	8 ft.	
50	3	3.2	0.1	0.002	0.004	0.006	0.008	0.009	0.011	0.013	0.015	
			0.3	0.006	0.011	0.017	0.022	0.028	0.033	0.038	0.044	
			0.5	0.009	0.019	0.028	0.037	0.045	0.054	0.062	0.071	
			0.7	0.013	0.026	0.038	0.051	0.062	0.074	0.086	0.097	
			3.4	0.1	0.004	0.008	0.012	0.016	0.020	0.024	0.027	0.031
				0.3	0.012	0.024	0.035	0.046	0.057	0.068	0.078	0.089
				0.5	0.020	0.039	0.057	0.075	0.092	0.109	0.125	0.141
				0.7	0.028	0.054	0.079	0.103	0.126	0.148	0.169	0.189
			3.6	0.1	0.010	0.020	0.029	0.038	0.048	0.057	0.065	0.074
				0.3	0.029	0.057	0.083	0.108	0.132	0.155	0.178	0.199
				0.5	0.048	0.093	0.134	0.172	0.207	0.241	0.272	0.303
				0.7	0.067	0.127	0.180	0.229	0.274	0.316	0.356	0.392
		3.8	0.1	0.024	0.047	0.069	0.091	0.111	0.131	0.150	0.168	
			0.3	0.071	0.133	0.189	0.240	0.287	0.331	0.371	0.409	
			0.5	0.116	0.211	0.292	0.364	0.428	0.486	0.540	0.589	
			0.7	0.159	0.282	0.384	0.471	0.548	0.616	0.679	0.736	
5	5	3.2	0.1	0.004	0.008	0.012	0.016	0.021	0.025	0.029	0.033	
			0.3	0.012	0.025	0.037	0.049	0.061	0.072	0.084	0.096	
			0.5	0.021	0.041	0.061	0.080	0.100	0.119	0.138	0.156	
			0.7	0.029	0.057	0.085	0.112	0.138	0.164	0.190	0.215	
			3.4	0.1	0.009	0.018	0.026	0.035	0.044	0.052	0.061	0.069
				0.3	0.027	0.052	0.078	0.103	0.127	0.152	0.175	0.198
				0.5	0.044	0.087	0.128	0.168	0.207	0.245	0.282	0.318
				0.7	0.062	0.121	0.177	0.231	0.283	0.334	0.382	0.429
			3.6	0.1	0.022	0.044	0.065	0.086	0.106	0.127	0.147	0.166
				0.3	0.066	0.129	0.188	0.246	0.301	0.354	0.405	0.454
				0.5	0.109	0.211	0.305	0.393	0.476	0.554	0.629	0.700
				0.7	0.153	0.290	0.415	0.530	0.636	0.736	0.829	0.917
		3.8	0.1	0.054	0.107	0.157	0.205	0.252	0.297	0.341	0.384	
			0.3	0.162	0.307	0.438	0.558	0.669	0.773	0.870	0.961	
			0.5	0.269	0.494	0.689	0.861	1.016	1.158	1.288	1.409	
			0.7	0.376	0.672	0.919	1.132	1.320	1.490	1.644	1.785	
7	7	3.2	0.1	0.007	0.014	0.021	0.028	0.035	0.042	0.049	0.056	
			0.3	0.021	0.043	0.064	0.085	0.105	0.126	0.146	0.166	
			0.5	0.036	0.071	0.106	0.140	0.173	0.207	0.240	0.272	
			0.7	0.050	0.099	0.147	0.194	0.240	0.286	0.331	0.375	
			3.4	0.1	0.015	0.031	0.046	0.061	0.076	0.091	0.106	0.121
				0.3	0.046	0.092	0.137	0.181	0.224	0.266	0.308	0.349
				0.5	0.077	0.153	0.225	0.296	0.365	0.432	0.498	0.562
				0.7	0.109	0.213	0.313	0.409	0.501	0.591	0.678	0.762
			3.6	0.1	0.039	0.077	0.115	0.152	0.188	0.224	0.259	0.294
				0.3	0.117	0.228	0.335	0.437	0.536	0.631	0.723	0.811
				0.5	0.195	0.376	0.545	0.704	0.854	0.997	1.132	1.261
				0.7	0.274	0.522	0.748	0.956	1.150	1.332	1.503	1.664
		3.8	0.1	—	—	—	—	—	—	—	—	

**TABLE 18-III-X—DIFFERENTIAL SWELL OCCURRING AT THE PERIMETER OF A SLAB FOR AN EDGE LIFT SWELLING CONDITION IN PREDOMINANTLY ILLITE CLAY SOIL (60 PERCENT CLAY)**

PERCENT CLAY (%)	DEPTH TO CONSTANT SUCTION (ft.) × 304.8 for mm	CONSTANT SUCTION (pF)	VELOCITY OF MOISTURE FLOW (inches/month) × 25.4 for mm/month	DIFFERENTIAL SWELL (inch)							
				× 25.4 for mm							
				Edge Distance Penetration							
				× 304.8 for mm							
				1 ft.	2 ft.	3 ft.	4 ft.	5 ft.	6 ft.	7 ft.	8 ft.
60	3	3.2	0.1	0.002	0.005	0.007	0.009	0.012	0.014	0.016	0.018
			0.3	0.007	0.014	0.021	0.027	0.034	0.041	0.047	0.054
			0.5	0.012	0.023	0.034	0.045	0.056	0.067	0.077	0.087
			0.7	0.016	0.032	0.047	0.062	0.077	0.092	0.106	0.119
		3.4	0.1	0.005	0.010	0.015	0.020	0.024	0.029	0.034	0.039
			0.3	0.015	0.029	0.043	0.057	0.071	0.084	0.097	0.110
			0.5	0.025	0.048	0.071	0.093	0.114	0.135	0.155	0.174
			0.7	0.034	0.067	0.097	0.127	0.155	0.182	0.208	0.234
		3.6	0.1	0.012	0.024	0.036	0.047	0.059	0.070	0.081	0.092
			0.3	0.036	0.070	0.103	0.134	0.164	0.192	0.219	0.245
			0.5	0.060	0.114	0.165	0.212	0.256	0.297	0.337	0.374
			0.7	0.083	0.156	0.223	0.283	0.339	0.391	0.439	0.485
		3.8	0.1	0.030	0.058	0.086	0.112	0.137	0.162	0.185	0.208
			0.3	0.088	0.165	0.234	0.297	0.355	0.409	0.459	0.506
			0.5	0.143	0.260	0.361	0.450	0.529	0.601	0.667	0.728
			0.7	0.196	0.348	0.474	0.582	0.677	0.761	0.838	0.909
5	3.2	3.2	0.1	0.005	0.010	0.015	0.020	0.025	0.030	0.035	0.040
			0.3	0.015	0.030	0.045	0.060	0.075	0.089	0.104	0.118
			0.5	0.025	0.050	0.075	0.099	0.123	0.147	0.170	0.193
			0.7	0.036	0.070	0.104	0.138	0.171	0.203	0.234	0.265
		3.4	0.1	0.011	0.022	0.033	0.043	0.054	0.064	0.075	0.085
			0.3	0.033	0.065	0.096	0.127	0.157	0.187	0.216	0.245
			0.5	0.055	0.107	0.158	0.208	0.256	0.303	0.348	0.393
			0.7	0.076	0.149	0.219	0.286	0.350	0.412	0.472	0.530
		3.6	0.1	0.027	0.054	0.080	0.106	0.132	0.157	0.181	0.206
			0.3	0.081	0.159	0.233	0.303	0.371	0.437	0.500	0.561
			0.5	0.135	0.260	0.376	0.485	0.588	0.685	0.777	0.864
			0.7	0.189	0.358	0.512	0.654	0.786	0.908	1.024	1.133
		3.8	0.1	0.067	0.132	0.194	0.254	0.311	0.367	0.422	0.474
			0.3	0.201	0.379	0.541	0.690	0.827	0.955	1.074	1.187
			0.5	0.333	0.611	0.851	1.064	1.255	1.430	1.591	1.740
			0.7	0.465	0.830	1.135	1.398	1.631	1.840	2.030	2.205
7	3.2	3.2	0.1	0.009	0.018	0.026	0.035	0.044	0.052	0.061	0.070
			0.3	0.026	0.053	0.079	0.104	0.130	0.155	0.180	0.205
			0.5	0.044	0.088	0.130	0.173	0.214	0.255	0.296	0.336
			0.7	0.062	0.122	0.182	0.240	0.297	0.353	0.408	0.463
		3.4	0.1	0.019	0.038	0.057	0.076	0.094	0.113	0.131	0.149
			0.3	0.057	0.114	0.169	0.223	0.276	0.329	0.380	0.431
			0.5	0.096	0.188	0.278	0.366	0.451	0.534	0.615	0.694
			0.7	0.134	0.263	0.386	0.505	0.619	0.730	0.837	0.941
		3.6	0.1	0.048	0.095	0.141	0.187	0.232	0.277	0.320	0.364
			0.3	0.144	0.282	0.414	0.540	0.662	0.779	0.893	1.002
			0.5	0.241	0.465	0.674	0.870	1.055	1.231	1.398	1.558
			0.7	0.339	0.644	0.924	1.181	1.421	1.645	1.856	2.055
		3.8	0.1	—	—	—	—	—	—	—	

**TABLE 18-III-Y—DIFFERENTIAL SWELL OCCURRING AT THE PERIMETER OF A SLAB FOR AN EDGE LIFT SWELLING CONDITION IN PREDOMINANTLY ILLITE CLAY SOIL (70 PERCENT CLAY)**

PERCENT CLAY (%)	DEPTH TO CONSTANT SUCTION (ft.) × 304.8 for mm	CONSTANT SUCTION (pF)	VELOCITY OF MOISTURE FLOW (inches/month) × 25.4 for mm/month	DIFFERENTIAL SWELL (inch)								
				× 25.4 for mm								
				Edge Distance Penetration								
				× 304.8 for mm								
				1 ft.	2 ft.	3 ft.	4 ft.	5 ft.	6 ft.	7 ft.	8 ft.	
70	3	3.2	0.1	0.003	0.006	0.008	0.011	0.014	0.017	0.019	0.022	
			0.3	0.008	0.017	0.025	0.033	0.041	0.048	0.056	0.064	
			0.5	0.014	0.027	0.041	0.054	0.067	0.079	0.092	0.104	
			0.7	0.019	0.038	0.056	0.074	0.092	0.109	0.126	0.142	
			3.4	0.1	0.006	0.012	0.018	0.023	0.029	0.035	0.040	0.046
				0.3	0.018	0.035	0.052	0.068	0.084	0.100	0.115	0.130
				0.5	0.029	0.057	0.084	0.111	0.136	0.160	0.184	0.207
				0.7	0.041	0.079	0.116	0.151	0.185	0.217	0.248	0.278
			3.6	0.1	0.015	0.029	0.043	0.056	0.070	0.083	0.096	0.109
				0.3	0.043	0.084	0.123	0.159	0.195	0.229	0.261	0.292
				0.5	0.071	0.136	0.196	0.252	0.305	0.354	0.401	0.445
				0.7	0.099	0.186	0.265	0.337	0.403	0.465	0.523	0.577
		3.8	0.1	0.036	0.070	0.102	0.133	0.163	0.192	0.220	0.247	
			0.3	0.104	0.196	0.279	0.354	0.422	0.486	0.546	0.602	
			0.5	0.170	0.310	0.430	0.535	0.630	0.715	0.794	0.866	
			0.7	0.234	0.415	0.564	0.692	0.805	0.906	0.998	1.082	
5	3.2	3.2	0.1	0.006	0.012	0.018	0.024	0.030	0.036	0.042	0.048	
			0.3	0.018	0.036	0.054	0.072	0.089	0.106	0.124	0.141	
			0.5	0.030	0.060	0.089	0.118	0.147	0.175	0.202	0.230	
			0.7	0.042	0.084	0.124	0.164	0.203	0.241	0.279	0.315	
			3.4	0.1	0.013	0.026	0.039	0.052	0.064	0.077	0.089	0.102
				0.3	0.039	0.077	0.115	0.151	0.187	0.223	0.258	0.292
				0.5	0.065	0.128	0.188	0.247	0.305	0.360	0.414	0.467
				0.7	0.091	0.177	0.260	0.340	0.417	0.490	0.562	0.631
			3.6	0.1	0.032	0.064	0.095	0.126	0.157	0.186	0.216	0.245
				0.3	0.097	0.189	0.277	0.361	0.442	0.520	0.595	0.667
				0.5	0.161	0.309	0.448	0.577	0.699	0.815	0.925	1.029
				0.7	0.225	0.426	0.610	0.779	0.935	1.081	1.219	1.348
		3.8	0.1	0.080	0.157	0.231	0.302	0.371	0.437	0.502	0.564	
			0.3	0.239	0.452	0.644	0.821	0.984	1.136	1.279	1.413	
			0.5	0.396	0.727	1.013	1.266	1.494	1.702	1.894	2.072	
			0.7	0.563	0.988	1.351	1.664	1.941	2.190	2.417	2.625	
7	3.2	3.2	0.1	0.011	0.021	0.031	0.042	0.052	0.062	0.073	0.083	
			0.3	0.031	0.063	0.094	0.124	0.155	0.185	0.215	0.244	
			0.5	0.062	0.104	0.155	0.205	0.255	0.304	0.352	0.400	
			0.7	0.074	0.146	0.216	0.285	0.354	0.420	0.486	0.551	
			3.4	0.1	0.023	0.045	0.068	0.090	0.112	0.134	0.156	0.178
				0.3	0.068	0.135	0.201	0.266	0.329	0.391	0.453	0.513
				0.5	0.114	0.224	0.331	0.436	0.537	0.636	0.732	0.826
				0.7	0.160	0.313	0.459	0.601	0.737	0.869	0.996	1.120
			3.6	0.1	0.057	0.113	0.168	0.223	0.276	0.329	0.381	0.433
				0.3	0.172	0.335	0.492	0.643	0.788	0.928	1.063	1.193
				0.5	0.287	0.553	0.802	1.036	1.256	1.465	1.664	1.854
				0.7	0.403	0.767	1.099	1.406	1.691	1.958	2.209	2.447
		3.8	0.1	—	—	—	—	—	—	—	—	
			0.3	—	—	—	—	—	—	—	—	
			0.5	—	—	—	—	—	—	—	—	
			0.7	—	—	—	—	—	—	—	—	

**TABLE 18-III-Z—DIFFERENTIAL SWELL OCCURRING AT THE PERIMETER OF A SLAB FOR AN EDGE LIFT SWELLING CONDITION IN PREDOMINANTLY MONTMORILLONITE CLAY SOIL (30 PERCENT CLAY)**

PERCENT CLAY (%)	DEPTH TO CONSTANT SUCTION (ft.) × 304.8 for mm	CONSTANT SUCTION (pF)	VELOCITY OF MOISTURE FLOW (inches/month) × 25.4 for mm/month	DIFFERENTIAL SWELL (inch)								
				× 25.4 for mm								
				Edge Distance Penetration								
				× 304.8 for mm								
				1 ft.	2 ft.	3 ft.	4 ft.	5 ft.	6 ft.	7 ft.	8 ft.	
30	3	3.2	0.1	0.001	0.002	0.004	0.005	0.006	0.007	0.008	0.009	
			0.3	0.004	0.007	0.010	0.014	0.017	0.021	0.024	0.027	
			0.5	0.006	0.012	0.017	0.023	0.028	0.034	0.039	0.044	
			0.7	0.008	0.016	0.024	0.032	0.039	0.046	0.053	0.060	
			3.4	0.1	0.003	0.005	0.007	0.010	0.012	0.015	0.017	0.019
				0.3	0.007	0.015	0.022	0.029	0.036	0.042	0.049	0.055
				0.5	0.012	0.024	0.036	0.047	0.058	0.068	0.078	0.088
				0.7	0.017	0.034	0.049	0.064	0.078	0.092	0.105	0.118
			3.6	0.1	0.006	0.012	0.018	0.024	0.030	0.035	0.041	0.046
				0.3	0.018	0.036	0.052	0.068	0.083	0.097	0.111	0.124
				0.5	0.030	0.058	0.083	0.107	0.129	0.150	0.170	0.189
				0.7	0.042	0.079	0.112	0.143	0.171	0.197	0.222	0.245
		3.8	0.1	0.015	0.030	0.043	0.057	0.069	0.082	0.093	0.105	
			0.3	0.044	0.083	0.118	0.150	0.179	0.206	0.232	0.255	
			0.5	0.072	0.132	0.182	0.227	0.267	0.303	0.337	0.368	
			0.7	0.099	0.176	0.239	0.294	0.342	0.385	0.423	0.459	
30	5	3.2	0.1	0.003	0.005	0.008	0.010	0.013	0.015	0.018	0.020	
			0.3	0.008	0.015	0.023	0.030	0.038	0.045	0.053	0.060	
			0.5	0.013	0.026	0.038	0.050	0.062	0.074	0.086	0.098	
			0.7	0.018	0.036	0.053	0.070	0.086	0.102	0.118	0.134	
			3.4	0.1	0.006	0.011	0.016	0.022	0.027	0.033	0.038	0.043
				0.3	0.017	0.033	0.049	0.064	0.080	0.095	0.109	0.124
				0.5	0.028	0.054	0.080	0.105	0.129	0.153	0.176	0.198
				0.7	0.039	0.075	0.110	0.144	0.177	0.208	0.238	0.268
			3.6	0.1	0.014	0.027	0.041	0.054	0.066	0.079	0.092	0.104
				0.3	0.041	0.080	0.118	0.153	0.188	0.221	0.252	0.283
				0.5	0.068	0.131	0.190	0.245	0.297	0.346	0.392	0.437
				0.7	0.095	0.181	0.259	0.330	0.397	0.459	0.517	0.572
		3.8	0.1	0.034	0.067	0.098	0.128	0.157	0.186	0.213	0.239	
			0.3	0.101	0.192	0.273	0.348	0.418	0.482	0.543	0.600	
			0.5	0.168	0.308	0.430	0.537	0.634	0.722	0.804	0.879	
			0.7	0.235	0.419	0.573	0.706	0.824	0.929	1.025	1.114	
30	7	3.2	0.1	0.004	0.009	0.013	0.018	0.022	0.027	0.031	0.035	
			0.3	0.013	0.027	0.040	0.053	0.066	0.078	0.091	0.104	
			0.5	0.022	0.044	0.066	0.087	0.108	0.129	0.150	0.170	
			0.7	0.031	0.062	0.092	0.121	0.150	0.178	0.206	0.234	
			3.4	0.1	0.010	0.019	0.029	0.038	0.048	0.057	0.066	0.075
				0.3	0.029	0.057	0.085	0.113	0.140	0.166	0.192	0.218
				0.5	0.048	0.095	0.141	0.185	0.228	0.270	0.311	0.361
				0.7	0.068	0.133	0.195	0.255	0.313	0.369	0.423	0.475
			3.6	0.1	0.024	0.048	0.071	0.095	0.117	0.140	0.162	0.184
				0.3	0.073	0.142	0.209	0.273	0.334	0.394	0.451	0.506
				0.5	0.122	0.235	0.340	0.439	0.533	0.622	0.706	0.787
				0.7	0.171	0.326	0.466	0.597	0.718	0.831	0.937	1.038
		3.8	0.1	—	—	—	—	—	—	—		

**TABLE 18-III-AA—DIFFERENTIAL SWELL OCCURRING AT THE PERIMETER OF A SLAB FOR AN EDGE LIFT SWELLING CONDITION IN PREDOMINANTLY MONTMORILLONITE CLAY SOIL (40 PERCENT CLAY)**

PERCENT CLAY (%)	DEPTH TO CONSTANT SUCTION (ft.) × 304.8 for mm	CONSTANT SUCTION (pF)	VELOCITY OF MOISTURE FLOW (inches/month) × 25.4 for mm/month	DIFFERENTIAL SWELL (inch)							
				× 25.4 for mm							
				Edge Distance Penetration							
				× 304.8 for mm							
				1 ft.	2 ft.	3 ft.	4 ft.	5 ft.	6 ft.	7 ft.	8 ft.
40	3	3.2	0.1	0.002	0.003	0.005	0.007	0.008	0.010	0.012	0.013
			0.3	0.005	0.010	0.015	0.020	0.025	0.030	0.035	0.039
			0.5	0.009	0.017	0.025	0.033	0.041	0.049	0.056	0.064
			0.7	0.012	0.023	0.035	0.046	0.056	0.067	0.077	0.087
		3.4	0.1	0.004	0.007	0.011	0.014	0.018	0.021	0.025	0.028
			0.3	0.011	0.021	0.032	0.042	0.052	0.061	0.071	0.080
			0.5	0.018	0.035	0.052	0.068	0.084	0.099	0.113	0.128
			0.7	0.025	0.049	0.071	0.093	0.114	0.133	0.153	0.171
		3.6	0.1	0.009	0.018	0.026	0.035	0.043	0.051	0.059	0.067
			0.3	0.027	0.052	0.075	0.098	0.120	0.141	0.160	0.180
			0.5	0.044	0.084	0.121	0.155	0.187	0.218	0.246	0.274
			0.7	0.061	0.114	0.163	0.207	0.248	0.286	0.321	0.355
		3.8	0.1	0.022	0.043	0.063	0.082	0.100	0.118	0.135	0.152
			0.3	0.064	0.121	0.171	0.217	0.260	0.299	0.336	0.370
			0.5	0.105	0.191	0.264	0.329	0.387	0.440	0.488	0.533
			0.7	0.144	0.255	0.347	0.426	0.495	0.557	0.614	0.665
	5	3.2	0.1	0.004	0.007	0.011	0.015	0.019	0.022	0.026	0.030
			0.3	0.011	0.022	0.033	0.044	0.055	0.065	0.076	0.087
			0.5	0.019	0.037	0.055	0.073	0.090	0.107	0.125	0.141
			0.7	0.026	0.052	0.076	0.101	0.125	0.148	0.171	0.194
		3.4	0.1	0.008	0.016	0.024	0.032	0.039	0.047	0.055	0.062
			0.3	0.024	0.047	0.070	0.093	0.115	0.137	0.158	0.179
			0.5	0.040	0.078	0.116	0.152	0.187	0.221	0.255	0.287
			0.7	0.056	0.109	0.160	0.209	0.256	0.302	0.345	0.388
		3.6	0.1	0.020	0.039	0.059	0.078	0.096	0.115	0.133	0.150
			0.3	0.060	0.116	0.170	0.222	0.272	0.320	0.366	0.410
			0.5	0.099	0.190	0.275	0.355	0.430	0.501	0.568	0.633
			0.7	0.138	0.262	0.375	0.479	0.575	0.665	0.749	0.829
		3.8	0.1	0.049	0.096	0.142	0.186	0.228	0.269	0.309	0.347
			0.3	0.147	0.278	0.396	0.505	0.605	0.699	0.786	0.869
			0.5	0.244	0.447	0.623	0.779	0.919	1.047	1.164	1.274
			0.7	0.340	0.607	0.831	1.023	1.193	1.347	1.486	1.614
	7	3.2	0.1	0.006	0.013	0.019	0.026	0.032	0.038	0.045	0.051
			0.3	0.019	0.039	0.058	0.076	0.095	0.114	0.132	0.150
			0.5	0.032	0.064	0.095	0.126	0.157	0.187	0.217	0.246
			0.7	0.045	0.089	0.133	0.176	0.217	0.258	0.299	0.339
		3.4	0.1	0.014	0.028	0.042	0.055	0.069	0.083	0.096	0.109
			0.3	0.042	0.083	0.124	0.163	0.202	0.241	0.278	0.316
			0.5	0.070	0.138	0.204	0.268	0.330	0.391	0.450	0.508
			0.7	0.098	0.192	0.283	0.369	0.453	0.534	0.613	0.689
		3.6	0.1	0.035	0.070	0.104	0.137	0.170	0.202	0.235	0.266
			0.3	0.106	0.206	0.303	0.395	0.484	0.570	0.653	0.734
			0.5	0.176	0.340	0.493	0.637	0.772	0.901	1.023	1.140
			0.7	0.248	0.472	0.676	0.864	1.040	1.204	1.358	1.504
		3.8	0.1	—	—	—	—	—	—	—	

**TABLE 18-III-BB—DIFFERENTIAL SWELL OCCURRING AT THE PERIMETER OF A SLAB FOR AN EDGE LIFT SWELLING CONDITION IN PREDOMINANTLY MONTMORILLONITE CLAY SOIL (50 PERCENT CLAY)**

PERCENT CLAY (%)	DEPTH TO CONSTANT SUCTION (ft.) × 304.8 for mm	CONSTANT SUCTION (pF)	VELOCITY OF MOISTURE FLOW (Inches/month) × 25.4 for mm/month	DIFFERENTIAL SWELL (inch)							
				× 25.4 for mm							
				Edge Distance Penetration							
				× 304.8 for mm							
				1 ft.	2 ft.	3 ft.	4 ft.	5 ft.	6 ft.	7 ft.	8 ft.
50	3	3.2	0.1	0.002	0.004	0.007	0.009	0.011	0.013	0.015	0.018
			0.3	0.007	0.013	0.020	0.026	0.033	0.039	0.045	0.052
			0.5	0.011	0.022	0.033	0.043	0.054	0.064	0.074	0.084
			0.7	0.016	0.031	0.045	0.060	0.074	0.088	0.101	0.115
		3.4	0.1	0.005	0.009	0.014	0.019	0.023	0.028	0.032	0.037
			0.3	0.014	0.028	0.042	0.055	0.068	0.080	0.093	0.105
			0.5	0.024	0.046	0.068	0.089	0.109	0.129	0.148	0.167
			0.7	0.033	0.064	0.093	0.122	0.149	0.175	0.200	0.224
		3.6	0.1	0.012	0.023	0.034	0.045	0.056	0.067	0.077	0.088
			0.3	0.035	0.068	0.099	0.128	0.157	0.184	0.210	0.235
			0.5	0.057	0.110	0.158	0.203	0.245	0.285	0.323	0.358
			0.7	0.079	0.150	0.213	0.271	0.325	0.375	0.421	0.465
		3.8	0.1	0.029	0.056	0.082	0.107	0.132	0.155	0.177	0.199
			0.3	0.084	0.158	0.224	0.285	0.340	0.392	0.440	0.485
			0.5	0.137	0.250	0.346	0.431	0.507	0.576	0.639	0.698
			0.7	0.188	0.334	0.454	0.558	0.649	0.730	0.804	0.871
	5	3.2	0.1	0.005	0.010	0.015	0.019	0.024	0.029	0.034	0.039
			0.3	0.015	0.029	0.044	0.058	0.072	0.086	0.100	0.113
			0.5	0.024	0.048	0.072	0.095	0.118	0.141	0.163	0.185
			0.7	0.034	0.067	0.100	0.132	0.163	0.194	0.224	0.254
		3.4	0.1	0.011	0.021	0.031	0.041	0.052	0.062	0.072	0.082
			0.3	0.031	0.062	0.092	0.122	0.151	0.179	0.207	0.235
			0.5	0.052	0.103	0.152	0.199	0.245	0.290	0.334	0.376
			0.7	0.073	0.143	0.210	0.274	0.335	0.395	0.452	0.508
		3.6	0.1	0.026	0.052	0.077	0.102	0.126	0.150	0.174	0.197
			0.3	0.078	0.152	0.223	0.291	0.356	0.419	0.479	0.538
			0.5	0.130	0.249	0.361	0.465	0.563	0.656	0.745	0.829
			0.7	0.181	0.343	0.491	0.627	0.753	0.871	0.981	1.086
		3.8	0.1	0.064	0.126	0.186	0.243	0.299	0.352	0.404	0.454
			0.3	0.192	0.364	0.519	0.661	0.793	0.915	1.030	1.138
			0.5	0.319	0.585	0.816	1.020	1.204	1.371	1.525	1.668
			0.7	0.445	0.796	1.088	1.340	1.563	1.764	1.946	2.114
	7	3.2	0.1	0.008	0.017	0.025	0.034	0.042	0.050	0.059	0.067
			0.3	0.025	0.050	0.075	0.100	0.125	0.149	0.173	0.197
			0.5	0.042	0.084	0.125	0.165	0.205	0.245	0.284	0.322
			0.7	0.059	0.117	0.174	0.230	0.285	0.339	0.391	0.443
		3.4	0.1	0.018	0.037	0.055	0.073	0.090	0.108	0.126	0.143
			0.3	0.055	0.109	0.162	0.214	0.265	0.315	0.365	0.413
			0.5	0.092	0.181	0.267	0.351	0.433	0.512	0.590	0.665
			0.7	0.129	0.252	0.370	0.484	0.594	0.700	0.802	0.902
		3.6	0.1	0.046	0.091	0.136	0.179	0.223	0.265	0.307	0.349
			0.3	0.138	0.270	0.397	0.518	0.635	0.747	0.856	0.961
			0.5	0.231	0.446	0.646	0.834	1.012	1.180	1.341	1.494
			0.7	0.325	0.618	0.885	1.132	1.362	1.577	1.779	1.970
		3.8	0.1	—	—	—	—	—	—	—	

**TABLE 18-III-CC—DIFFERENTIAL SWELL OCCURRING AT THE PERIMETER OF A SLAB FOR AN EDGE LIFT SWELLING CONDITION IN PREDOMINANTLY MONTMORILLONITE CLAY SOIL (60 PERCENT CLAY)**

PERCENT CLAY (%)	DEPTH TO CONSTANT SUCTION (ft.) × 304.8 for mm	CONSTANT SUCTION (pF)	VELOCITY OF MOISTURE FLOW (inches/month) × 25.4 for mm/month	DIFFERENTIAL SWELL (inch)							
				× 25.4 for mm							
				Edge Distance Penetration							
				× 304.8 for mm							
				1 ft.	2 ft.	3 ft.	4 ft.	5 ft.	6 ft.	7 ft.	8 ft.
60	3	3.2	0.1	0.003	0.006	0.008	0.011	0.014	0.016	0.019	0.022
			0.3	0.008	0.016	0.025	0.033	0.040	0.048	0.056	0.064
			0.5	0.014	0.027	0.041	0.054	0.066	0.079	0.091	0.104
			0.7	0.019	0.038	0.056	0.074	0.091	0.109	0.125	0.142
		3.4	0.1	0.006	0.012	0.017	0.023	0.029	0.035	0.040	0.046
			0.3	0.018	0.035	0.051	0.068	0.084	0.099	0.115	0.130
			0.5	0.029	0.057	0.084	0.110	0.135	0.160	0.183	0.206
			0.7	0.041	0.079	0.116	0.151	0.184	0.216	0.247	0.277
		3.6	0.1	0.014	0.029	0.043	0.056	0.070	0.083	0.096	0.109
			0.3	0.043	0.083	0.122	0.159	0.194	0.228	0.260	0.291
			0.5	0.071	0.136	0.195	0.251	0.303	0.352	0.399	0.433
			0.7	0.098	0.186	0.264	0.336	0.402	0.463	0.521	0.575
		3.8	0.1	0.035	0.069	0.102	0.133	0.163	0.191	0.219	0.246
			0.3	0.104	0.195	0.277	0.352	0.421	0.484	0.544	0.599
			0.5	0.169	0.309	0.428	0.533	0.627	0.712	0.790	0.863
			0.7	0.233	0.413	0.562	0.690	0.802	0.903	0.994	1.077
	5	3.2	0.1	0.006	0.012	0.018	0.024	0.030	0.036	0.042	0.048
			0.3	0.018	0.036	0.054	0.071	0.089	0.106	0.123	0.140
			0.5	0.030	0.060	0.090	0.118	0.146	0.174	0.202	0.229
			0.7	0.042	0.083	0.124	0.163	0.202	0.240	0.278	0.314
		3.4	0.1	0.013	0.026	0.039	0.051	0.064	0.076	0.089	0.101
			0.3	0.039	0.077	0.114	0.151	0.187	0.222	0.256	0.291
			0.5	0.065	0.127	0.188	0.246	0.303	0.359	0.413	0.465
			0.7	0.090	0.177	0.259	0.339	0.415	0.488	0.559	0.628
		3.6	0.1	0.032	0.064	0.095	0.126	0.156	0.186	0.215	0.244
			0.3	0.096	0.188	0.276	0.360	0.440	0.518	0.593	0.665
			0.5	0.160	0.308	0.446	0.575	0.697	0.812	0.921	1.025
			0.7	0.224	0.425	0.607	0.775	0.931	1.077	1.214	1.343
		3.8	0.1	0.080	0.156	0.230	0.301	0.369	0.436	0.500	0.562
			0.3	0.238	0.450	0.642	0.817	0.980	1.132	1.274	1.407
			0.5	0.395	0.724	1.009	1.261	1.488	1.695	1.886	2.063
			0.7	0.551	0.984	1.345	1.657	1.933	2.181	2.407	2.614
	7	3.2	0.1	0.010	0.021	0.031	0.042	0.052	0.062	0.072	0.083
			0.3	0.031	0.062	0.093	0.124	0.154	0.184	0.214	0.243
			0.5	0.052	0.104	0.155	0.205	0.254	0.303	0.351	0.398
			0.7	0.073	0.145	0.215	0.284	0.352	0.419	0.484	0.548
		3.4	0.1	0.023	0.045	0.067	0.090	0.112	0.134	0.155	0.177
			0.3	0.068	0.135	0.200	0.264	0.328	0.390	0.451	0.511
			0.5	0.113	0.223	0.330	0.434	0.535	0.633	0.729	0.823
			0.7	0.159	0.311	0.458	0.598	0.734	0.865	0.992	1.115
		3.6	0.1	0.057	0.113	0.168	0.222	0.275	0.328	0.380	0.431
			0.3	0.171	0.334	0.490	0.640	0.785	0.924	1.058	1.188
			0.5	0.286	0.551	0.799	1.031	1.251	1.459	1.658	1.847
			0.7	0.402	0.764	1.095	1.400	1.684	1.950	2.200	2.437
		3.8	0.1	—	—	—	—	—	—	—	

**TABLE 18-III-DD—DIFFERENTIAL SWELL OCCURRING AT THE PERIMETER OF A SLAB FOR AN EDGE LIFT SWELLING CONDITION IN PREDOMINANTLY MONTMORILLONITE CLAY SOIL (70 PERCENT CLAY)**

PERCENT CLAY (%)	DEPTH TO CONSTANT SUCTION (ft.) × 304.8 for mm	CONSTANT SUCTION (pF)	VELOCITY OF MOISTURE FLOW (inches/month) × 25.4 for mm/month	DIFFERENTIAL SWELL (inch)								
				× 25.4 for mm								
				Edge Distance Penetration								
				× 304.8 for mm								
				1 ft.	2 ft.	3 ft.	4 ft.	5 ft.	6 ft.	7 ft.	8 ft.	
70	3	3.2	0.1	0.003	0.007	0.010	0.013	0.016	0.020	0.023	0.026	
			0.3	0.010	0.020	0.029	0.039	0.048	0.058	0.067	0.076	
			0.5	0.016	0.032	0.048	0.064	0.079	0.094	0.109	0.123	
			0.7	0.023	0.045	0.067	0.088	0.109	0.129	0.149	0.169	
			3.4	0.1	0.007	0.014	0.021	0.028	0.034	0.041	0.048	0.054
				0.3	0.021	0.041	0.061	0.081	0.100	0.118	0.137	0.155
				0.5	0.035	0.068	0.100	0.131	0.161	0.190	0.219	0.246
				0.7	0.048	0.094	0.138	0.179	0.219	0.258	0.294	0.330
			3.6	0.1	0.017	0.034	0.051	0.067	0.083	0.099	0.114	0.129
				0.3	0.051	0.099	0.145	0.189	0.231	0.271	0.310	0.347
				0.5	0.084	0.162	0.233	0.299	0.361	0.420	0.475	0.528
				0.7	0.117	0.221	0.314	0.400	0.479	0.552	0.620	0.684
		3.8	0.1	0.042	0.082	0.121	0.158	0.194	0.228	0.261	0.293	
			0.3	0.124	0.233	0.330	0.419	0.501	0.577	0.648	0.714	
			0.5	0.202	0.368	0.510	0.635	0.747	0.849	0.942	1.028	
			0.7	0.277	0.492	0.669	0.822	0.955	1.075	1.184	1.284	
70	5	3.2	0.1	0.007	0.014	0.022	0.029	0.036	0.043	0.050	0.057	
			0.3	0.022	0.043	0.064	0.085	0.106	0.126	0.147	0.167	
			0.5	0.036	0.071	0.106	0.140	0.174	0.207	0.240	0.273	
			0.7	0.050	0.099	0.147	0.195	0.241	0.286	0.331	0.374	
			3.4	0.1	0.015	0.031	0.046	0.061	0.076	0.091	0.106	0.121
				0.3	0.046	0.092	0.136	0.179	0.222	0.264	0.306	0.346
				0.5	0.077	0.151	0.223	0.293	0.361	0.427	0.492	0.554
				0.7	0.108	0.210	0.309	0.403	0.494	0.582	0.666	0.748
			3.6	0.1	0.038	0.076	0.113	0.150	0.186	0.221	0.256	0.290
				0.3	0.115	0.224	0.329	0.429	0.525	0.617	0.706	0.792
				0.5	0.191	0.367	0.531	0.685	0.830	0.967	1.097	1.221
				0.7	0.267	0.506	0.724	0.924	1.110	1.283	1.446	1.600
		3.8	0.1	0.095	0.186	0.274	0.358	0.440	0.519	0.595	0.669	
			0.3	0.283	0.536	0.764	0.974	1.168	1.348	1.517	1.677	
			0.5	0.470	0.862	1.262	1.502	1.773	2.020	2.247	2.458	
			0.7	0.656	1.172	1.603	1.974	2.303	2.598	2.867	3.114	
70	7	3.2	0.1	0.012	0.025	0.037	0.050	0.062	0.074	0.086	0.098	
			0.3	0.037	0.074	0.111	0.147	0.183	0.219	0.255	0.290	
			0.5	0.062	0.124	0.184	0.244	0.303	0.361	0.418	0.475	
			0.7	0.087	0.173	0.256	0.339	0.419	0.499	0.577	0.653	
			3.4	0.1	0.027	0.054	0.080	0.107	0.133	0.159	0.185	0.211
				0.3	0.081	0.160	0.238	0.315	0.390	0.464	0.537	0.609
				0.5	0.135	0.266	0.393	0.517	0.637	0.754	0.869	0.980
				0.7	0.189	0.371	0.545	0.713	0.875	1.031	1.182	1.329
			3.6	0.1	0.068	0.134	0.200	0.264	0.328	0.391	0.453	0.514
				0.3	0.204	0.398	0.584	0.763	0.935	1.101	1.261	1.415
				0.5	0.341	0.656	0.951	1.229	1.490	1.739	1.975	2.200
				0.7	0.479	0.910	1.304	1.668	2.006	2.323	2.621	2.903
		3.8	0.1	—	—	—	—	—	—	—	—	
			0.3	—	—	—	—	—	—	—	—	
			0.5	—	—	—	—	—	—	—	—	

**TABLE 18-III-EE—COMPARISON OF METHODS OF DETERMINING  
CATION EXCHANGE CAPACITY**

SOIL SAMPLE	CATION EXCHANGE CAPACITY (meq/100gm)	
	ATOMIC ABSORPTION	SPECTROPHOTOMETER <sup>1</sup>
01 - 01	21.1	20.2
31 - 02	28.2	26.2
53 - 05	14.7	7.0
72 - 06	71.4	72.8
73 - 06	21.6	18.9
86 - 08	45.0	50.0

<sup>1</sup>Bausch & Lomb "Spectronic-20"

TABLE 18-III-FF—COMPARISON OF CLAY MINERAL DETERMINATION METHODS

SOIL SAMPLE	PERCENT CLAY	ATTERBERG LIMITS		C.E.C. (meq./100 gm)		AC	CEAc		PREDOMINANT CLAY MINERAL		
		PL	PI	Flame Photometer	Correlation Equation		Flame Photometer	Correlation Equation	Flame Photometer	Correlation Equation	X-ray Defraction Analysis
31-02	33.5	16.5	26.6	28.2	26.6	0.79	0.84	0.80	Smectite	Smectite	Smectite
72-06	50.0	32.5	41.8	71.4	58.7	0.84	1.43	1.17	Smectite	Smectite	Smectite
86-08	47.0	25.1	36.4	45.0	43.4	0.77	0.96	0.92	Smectite	Smectite	Smectite

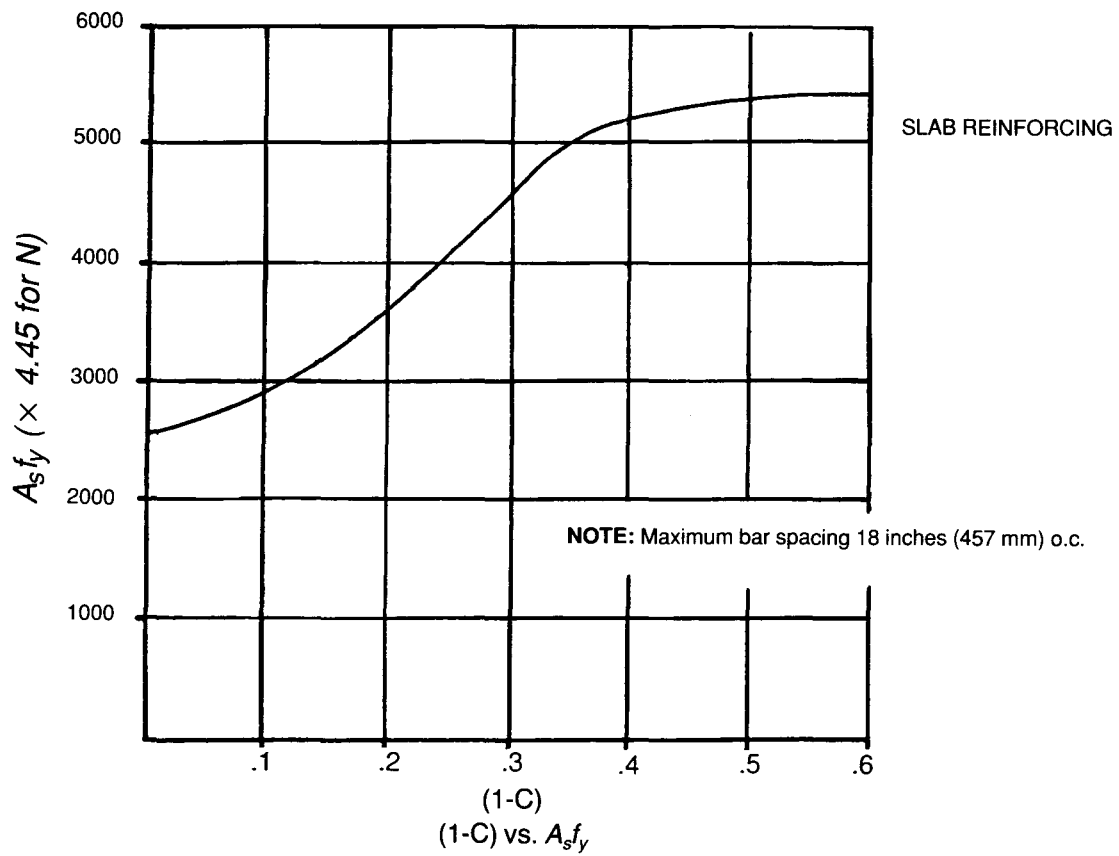
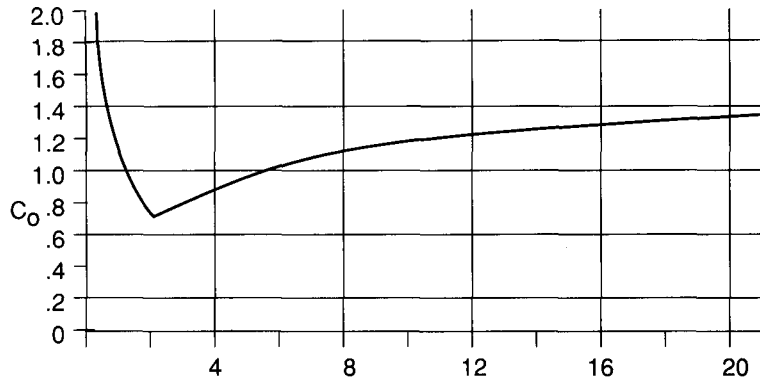

FIGURE 18-III-1



Unconfined Compressive Strength ( $q_u$ ) KSF  
(x 47.9 for kPa)

Unconfined compressive strength vs. overconsolidated  
correction coefficient

FIGURE 18-III-2

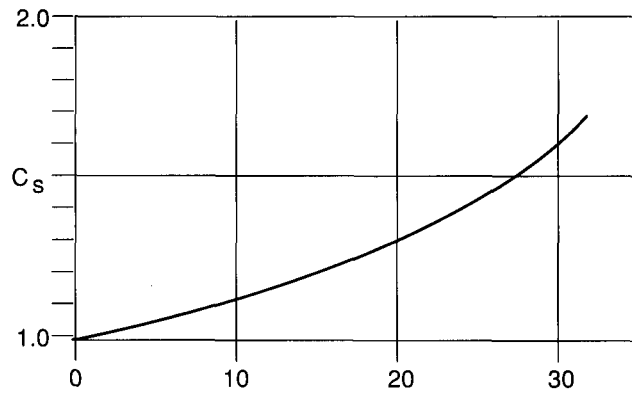

Slope % (of natural ground)

Slope of natural ground vs. slope correction coefficient

FIGURE 18-III-3

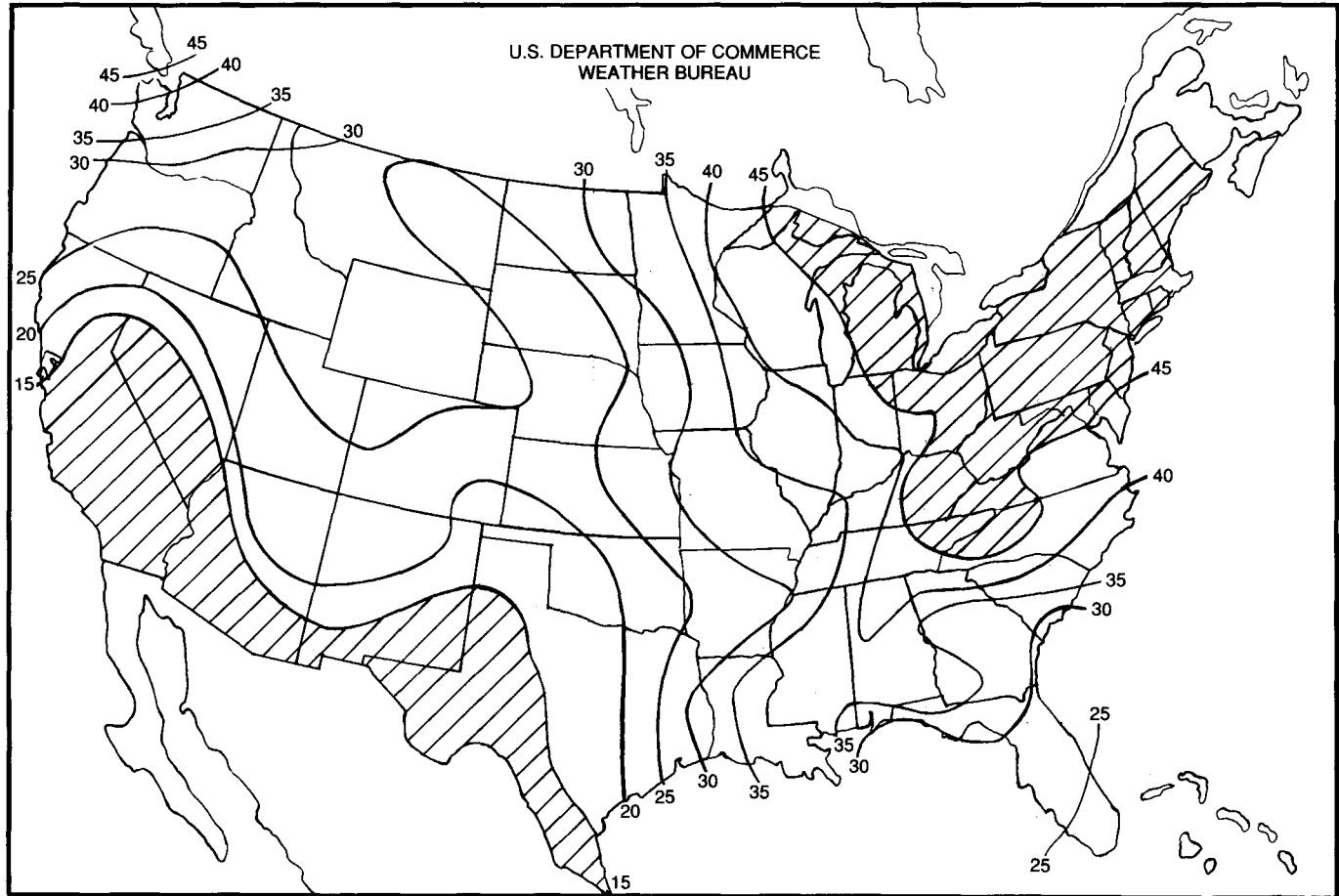

Climatic Rating ( $C_w$ ) Chart  
FIGURE 18-III-4

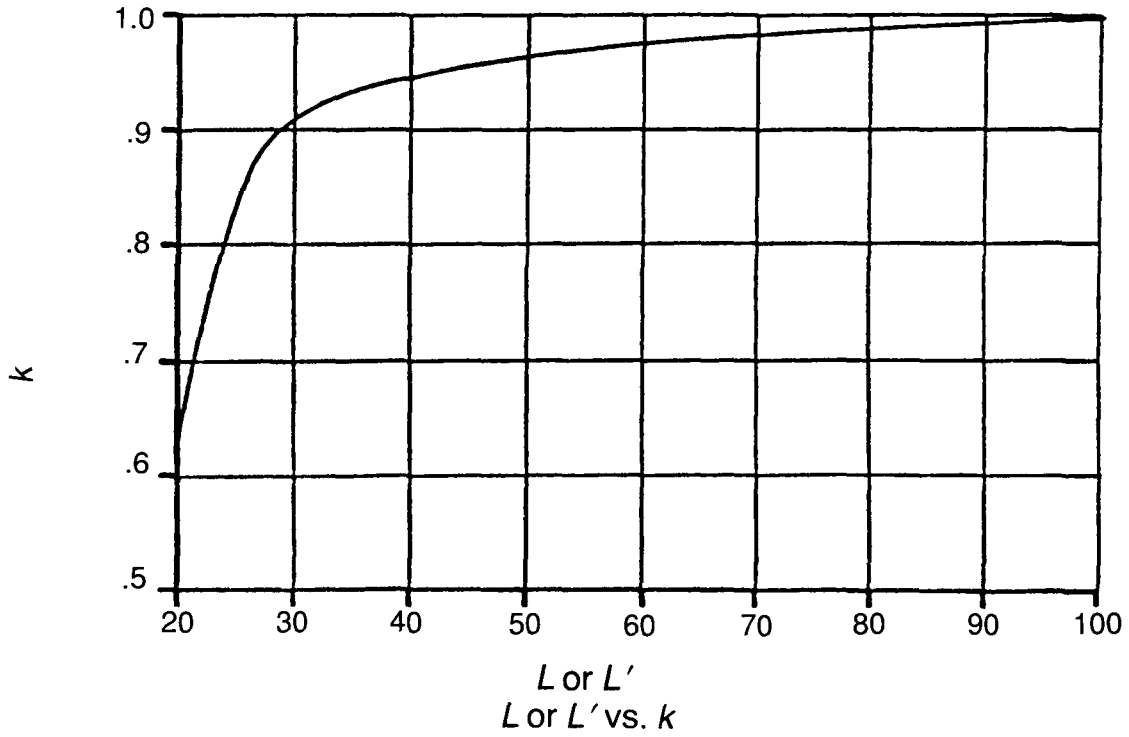
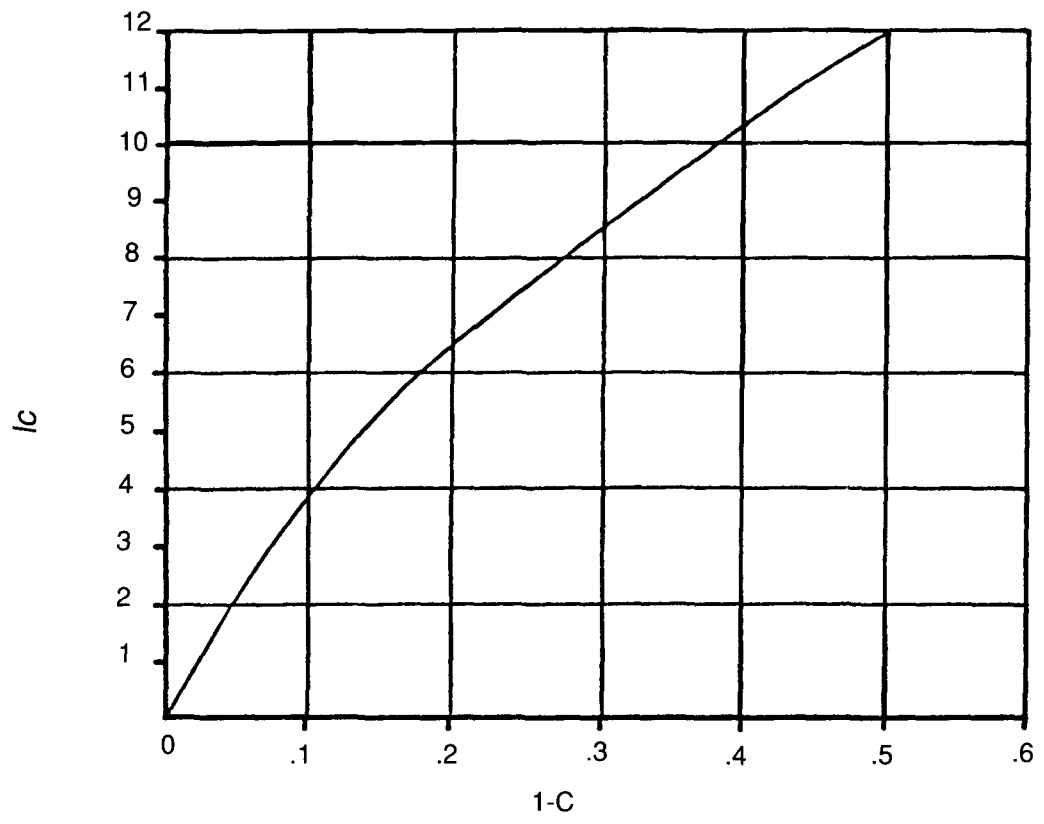
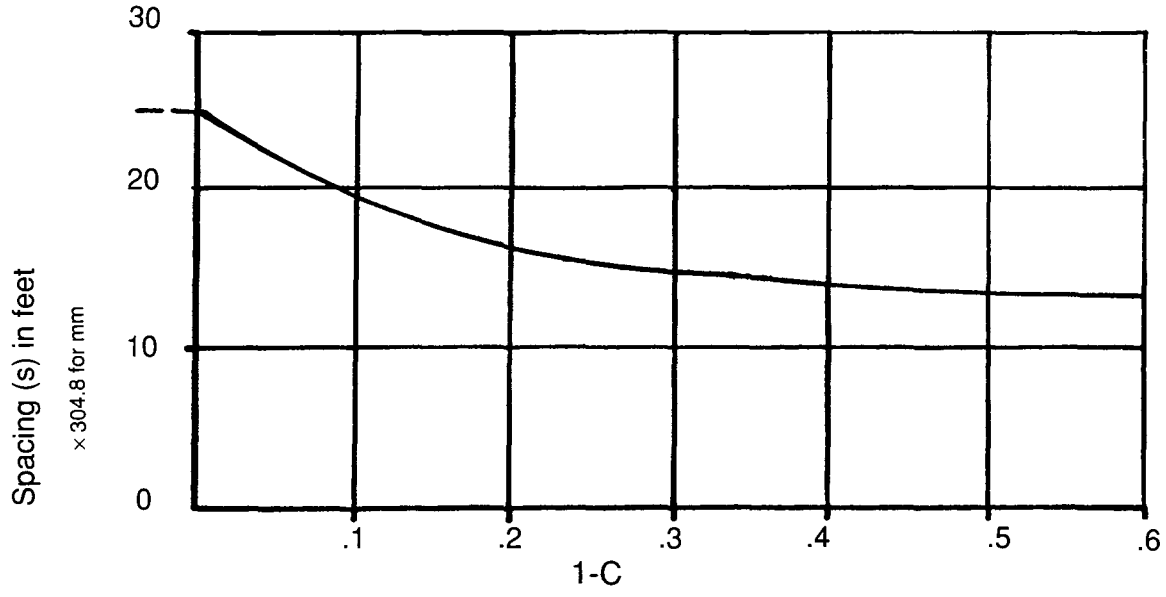

FIGURE 18-III-5



(1-C) vs. Cantilever Length ( $l_c$ )

FIGURE 18-III-6



1-C vs. Maximum beam spacing

FIGURE 18-III-7

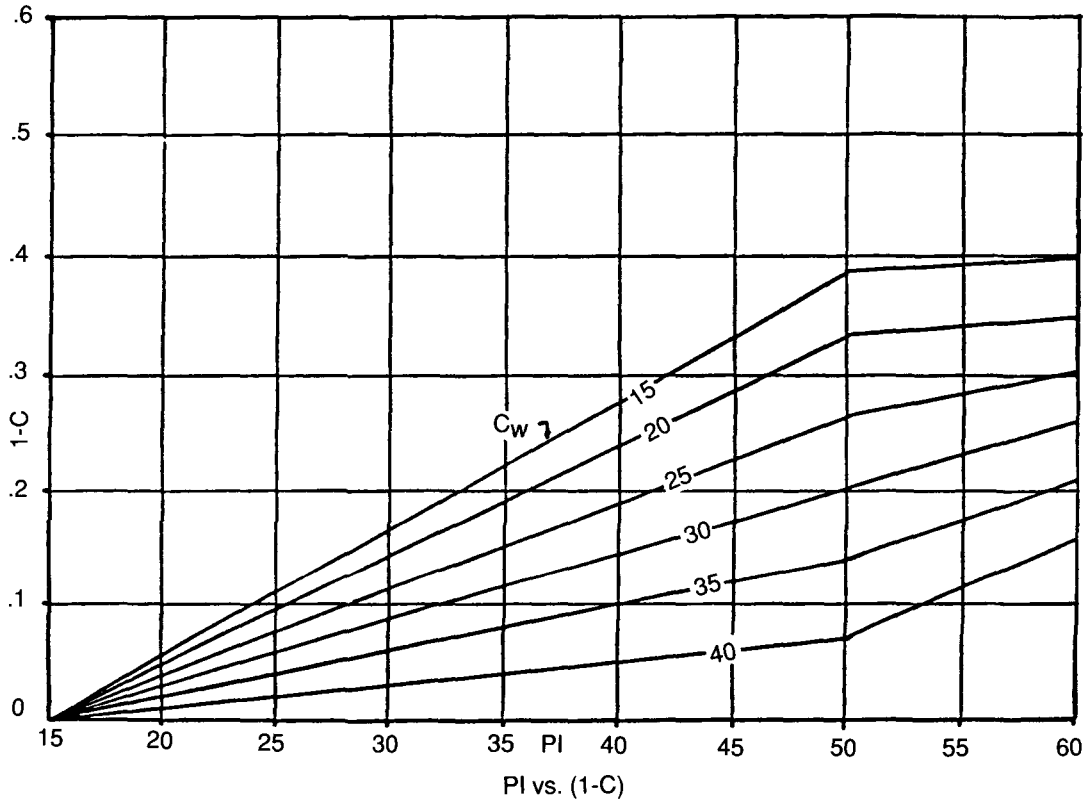
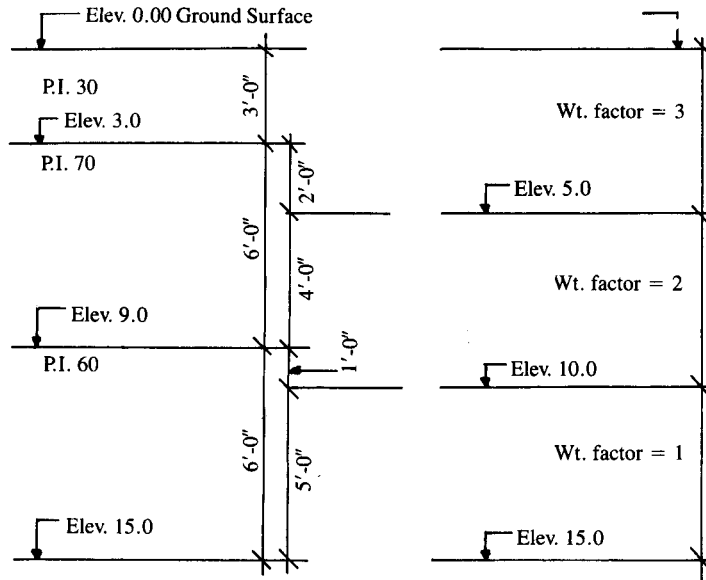

FIGURE 18-III-8

**DETERMINING THE WEIGHTED PLASTICITY INDEX (P.I.)**



Weight Factor	Depth	$F \times D$	P.I.	$F \times D \times P.I.$
<i>F</i>	<i>D</i>			
3	3	9	30	= 270
3	2	6	70	= 420
2	4	8	70	= 560
2	1	2	60	= 120
1	5	5	60	= 300
		<u>30</u>		<u>1670</u>

Weighted P.I. =  $1670/30 = 55.67$   
 = 56

**FIGURE 18-III-9**

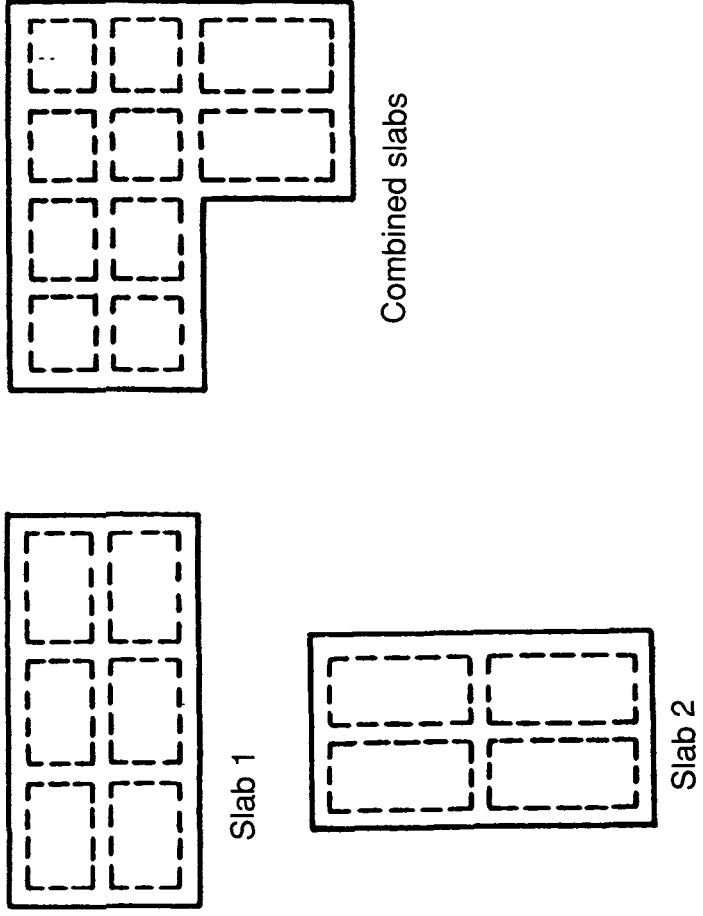

Slab Segments and Combined

FIGURE 18-III-10

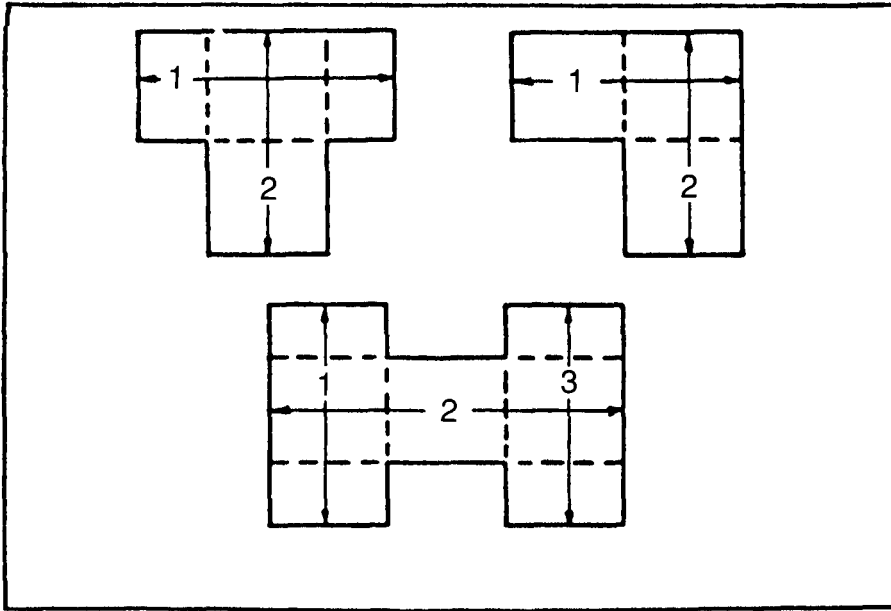
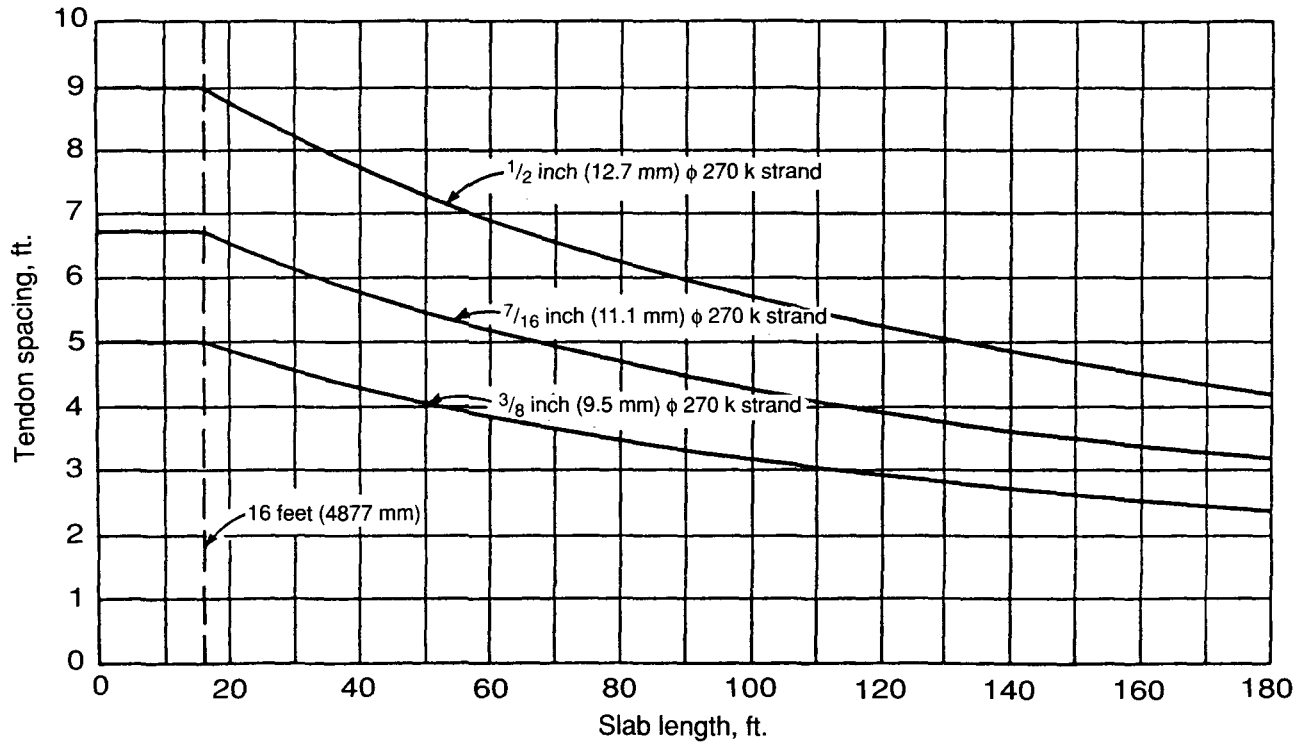

FIGURE 18-III-11—DESIGN RECTANGLES FOR SLABS OF IRREGULAR SHAPE



**FIGURE 18-III-12—MAXIMUM SLAB TENDON SPACING TO OVERCOME SLAB-SUBGRADE FRICTION (FRICTION COEFFICIENT = 0.75) AND RETAIN 50 PSI (344.5 kPa) RESIDUAL PRESTRESS COMPRESSION AT MIDPOINT OF STIFFENED SLAB ON GROUND**

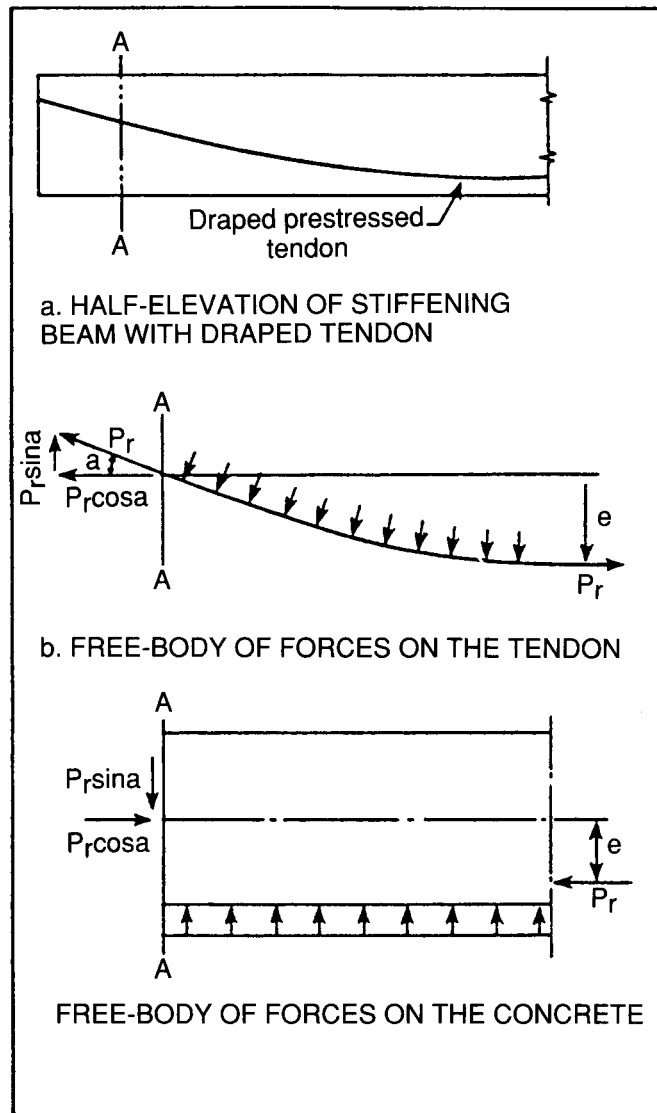

FIGURE 18-III-13—FREE-BODY DIAGRAMS FOR DRAPED BEAM TENDON AND CONCRETE SECTION

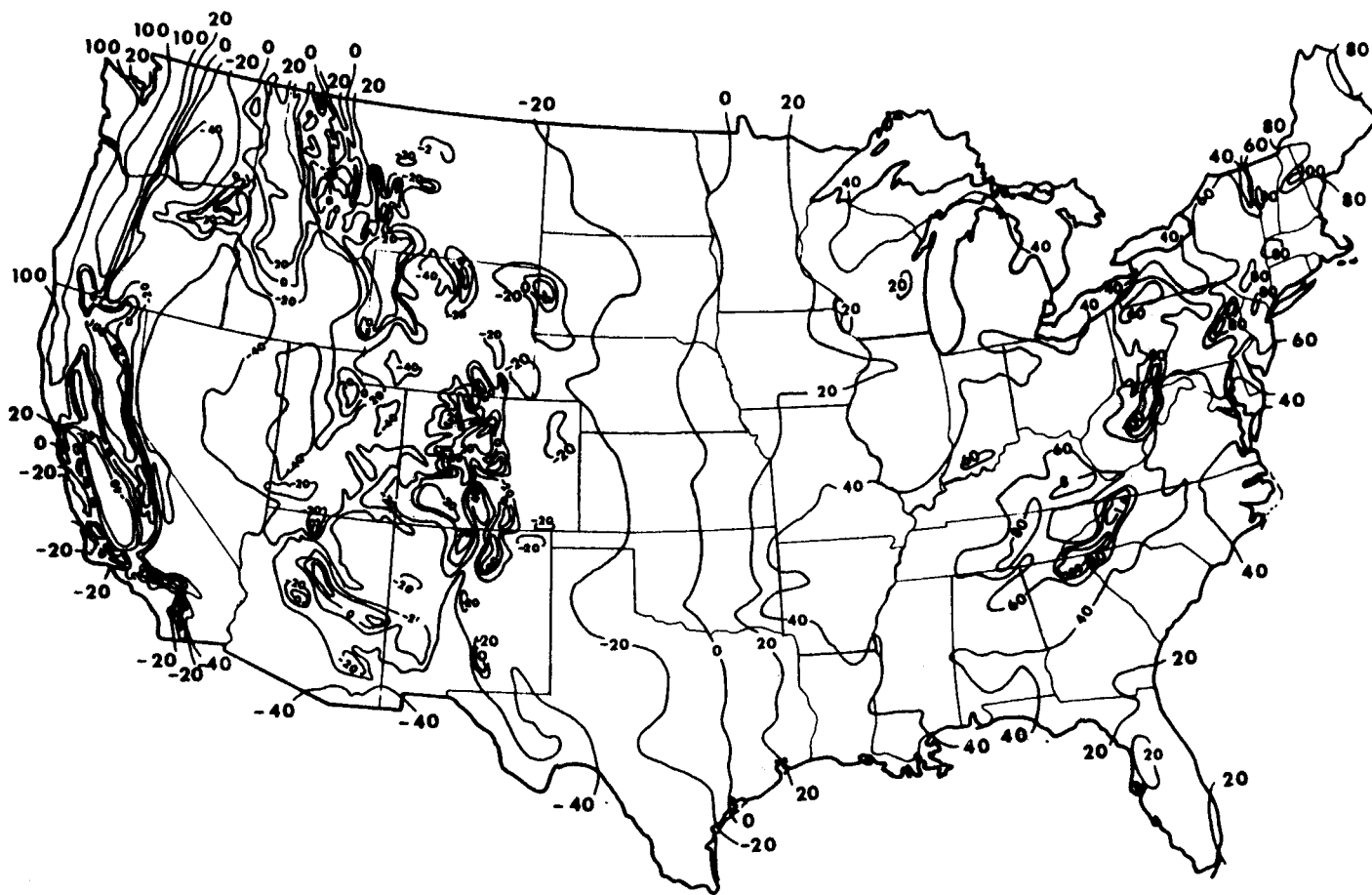

FIGURE 18-III-14—THORNTHWAITE MOISTURE INDEX DISTRIBUTION IN THE UNITED STATES

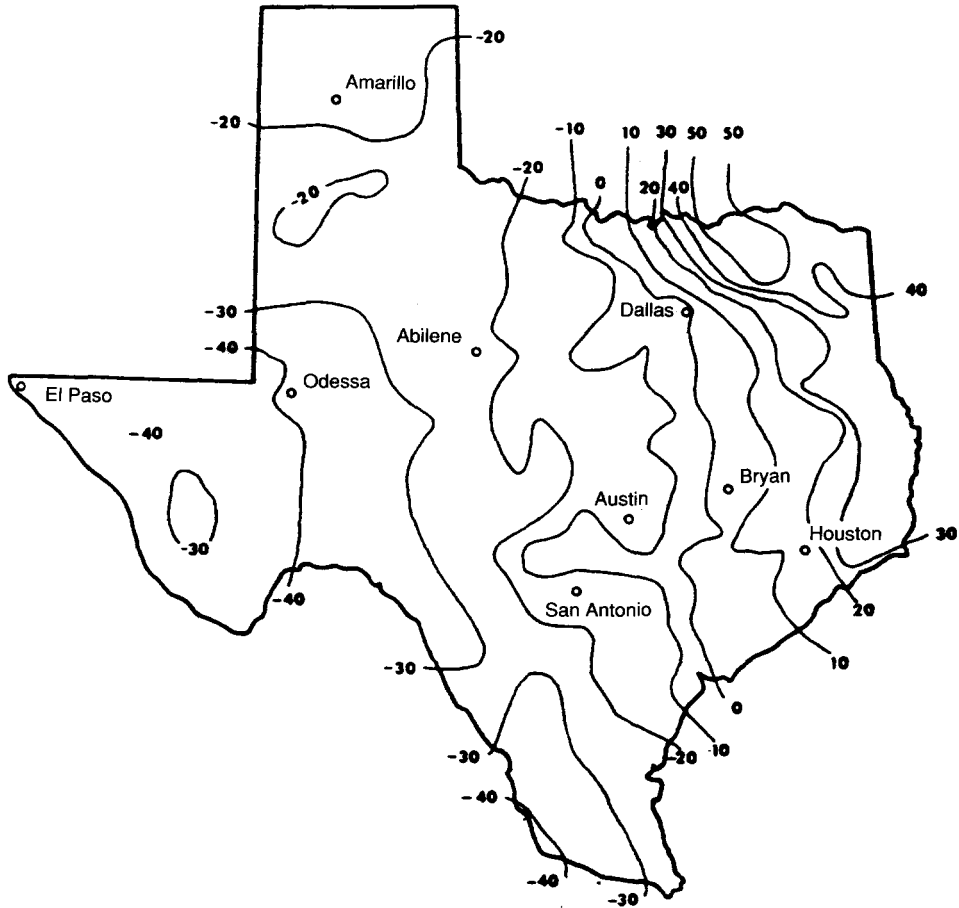

FIGURE NO. 18-III-15-1—THORNTHWAITE MOISTURE INDEX DISTRIBUTION FOR TEXAS (20-YEAR AVERAGE, 1955-1974)

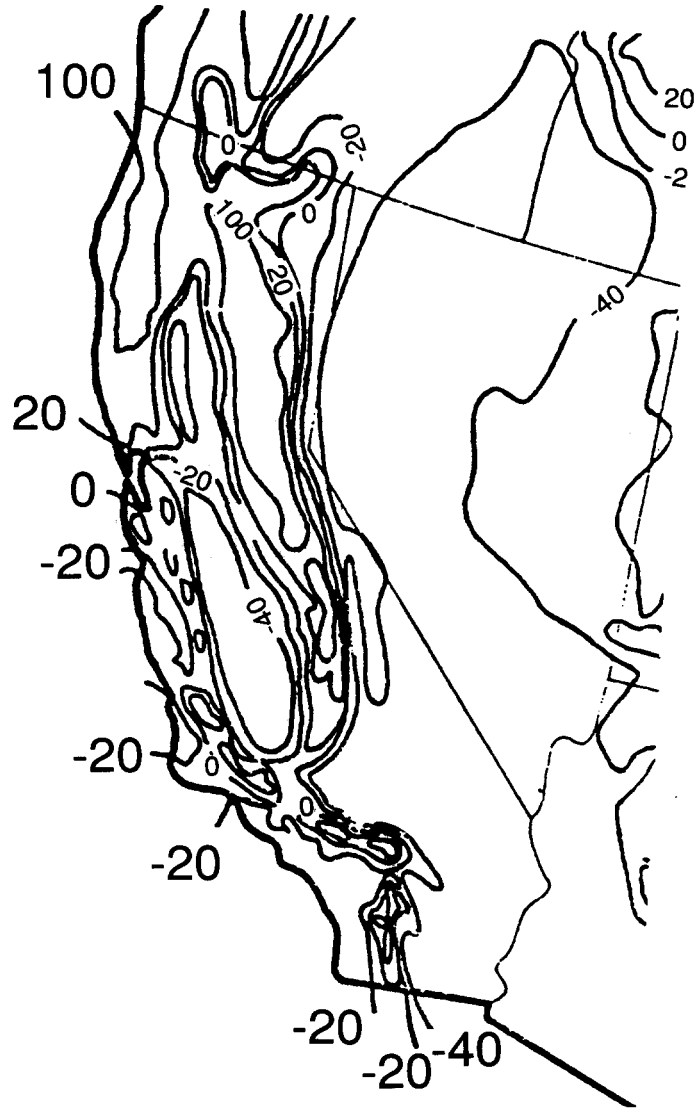

FIGURE 18-III-15-2—THORNTHWAITE MOISTURE INDEX DISTRIBUTION IN CALIFORNIA

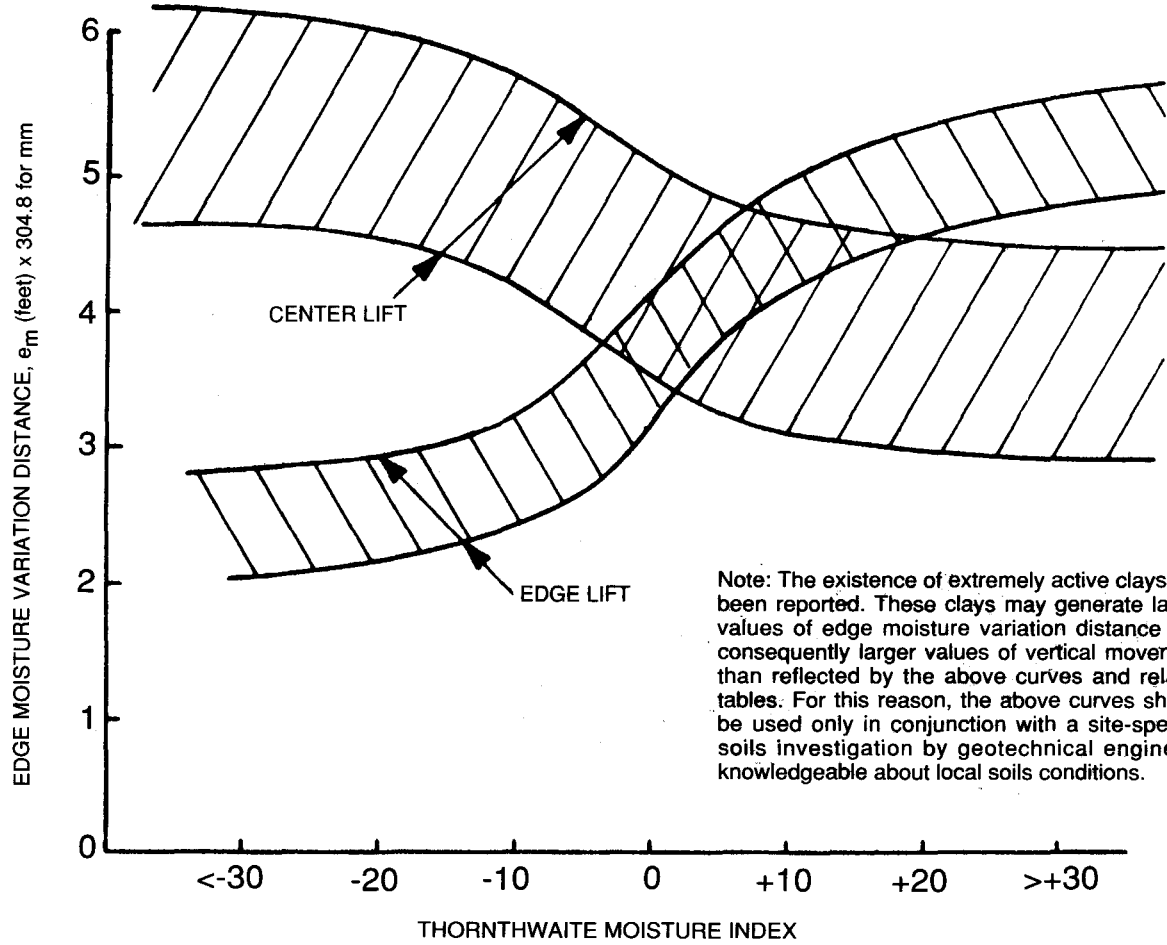
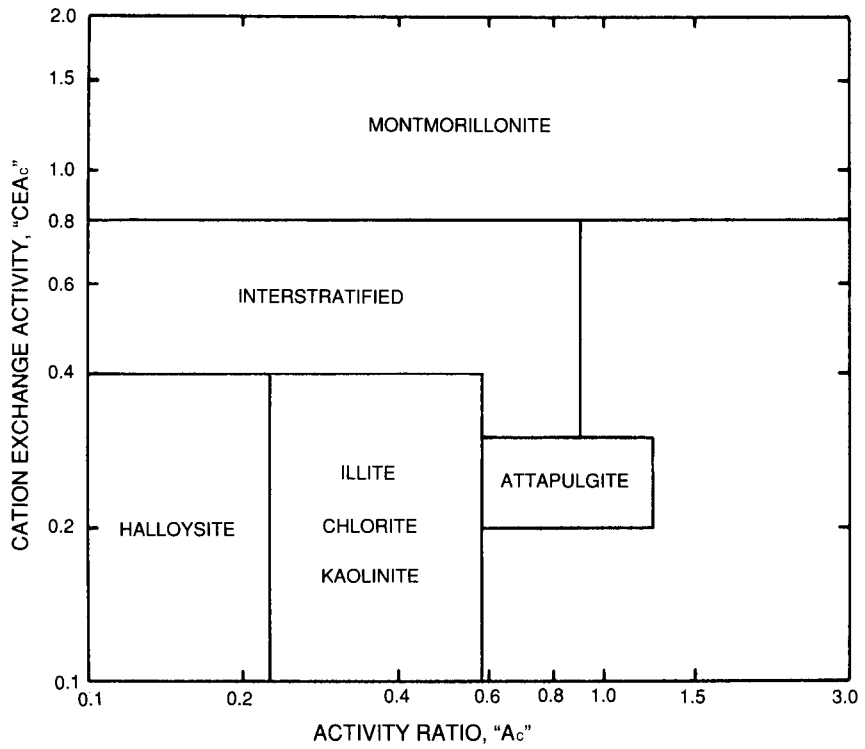

FIGURE 18-III-16—APPROXIMATE RELATIONSHIP BETWEEN THORNTHWAITE INDEX AND MOISTURE VARIATION DISTANCE



**FIGURE 18-III-17—CLAY TYPE CLASSIFICATION TO CATION EXCHANGE AND CLAY ACTIVITY RATIO AFTER PEARRING AND HOLT**

NOTE: For practical applications, the maximum value of pF will seldom exceed a magnitude of 3.6.

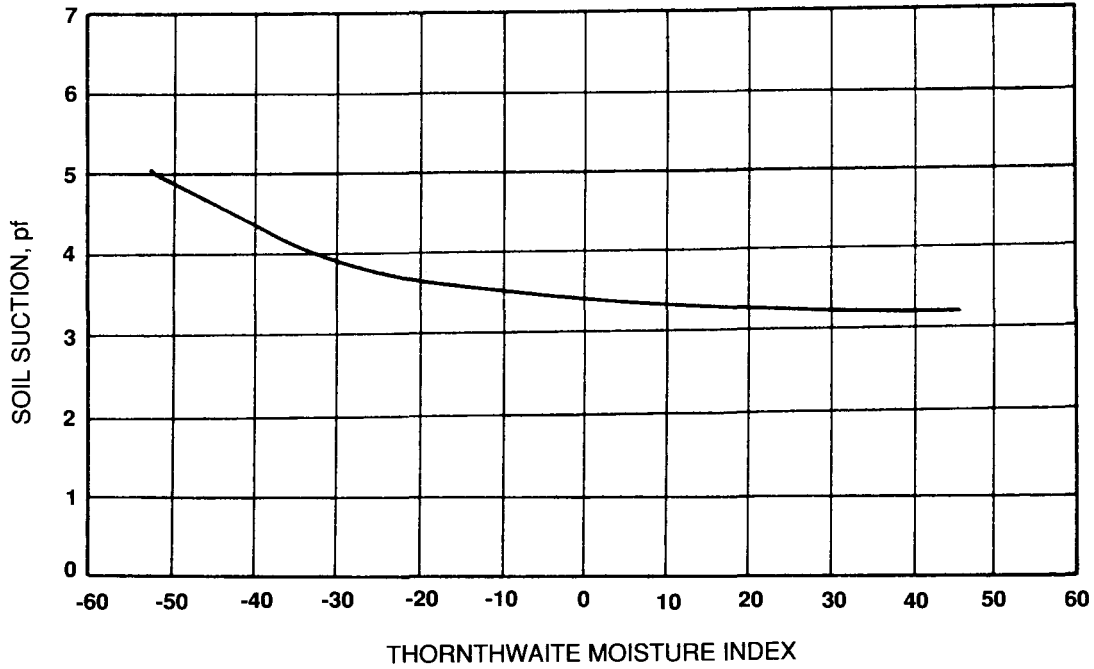
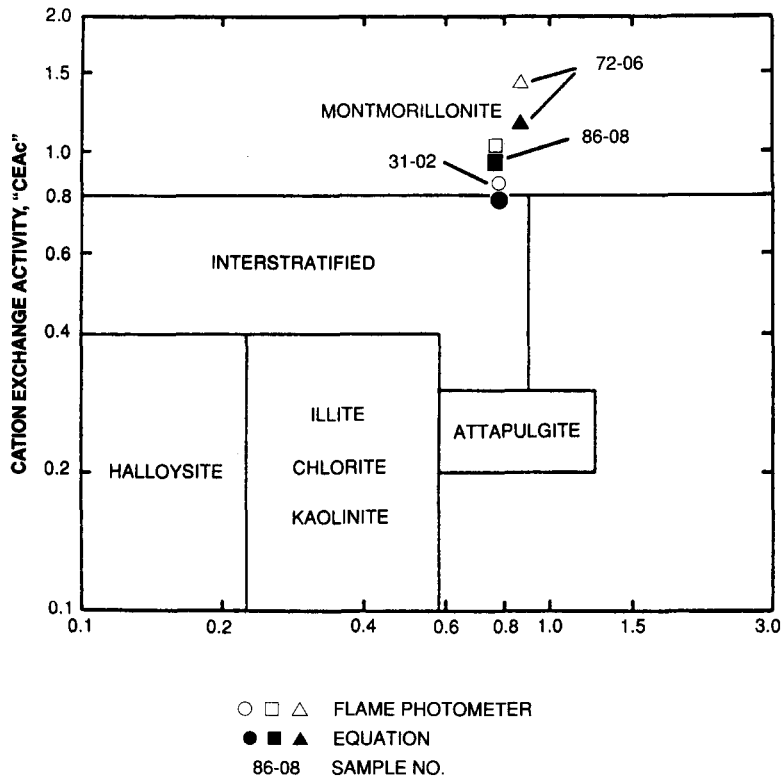

FIGURE 18-III-18—VARIATION OF CONSTANT SOIL SUCTION WITH THORNTHWAITE INDEX



**FIGURE 18-III-19—COMPARISON OF CLAY MINERAL DETERMINATION USING ATOMIC ABSORPTION AND CORRELATION EQUATIONS**

## Chapter 19 CONCRETE

Copyright © by the American Concrete Institute and reproduced with their consent. All rights reserved.

### SECTION 1900 — SOURCE

The contents of this chapter are patterned after, and in general conformity with, the provisions of Building Code Requirements for Reinforced Concrete (ACI 318-89) (revised 1992) and commentary—ACI 318 R-89 (revised 1992) and ACI Standard 318 for reinforced concrete design. For additional background information and research data see the referenced American Concrete Institute (ACI) publication.

In order to make reference to the ACI commentary easier for users of the code, the section designations of this chapter have been made similar to those found in ACI 318 (revised 1992). The first two digits of a section number indicates this chapter number and the balance matches the ACI chapter and section designation wherever possible. Italics are used in this chapter to indicate where the *Uniform Building Code* differs substantively from the ACI standard.

### SECTION 1901 — SCOPE

*The design of structures in concrete of cast-in-place or precast construction, plain, reinforced or prestressed, shall conform to the rules and principles specified in this chapter.*

### SECTION 1902 — DEFINITIONS

The following terms are defined for general use in this code. Specialized definitions appear in individual *sections*.

**ADMIXTURE** is material other than water, aggregate, or hydraulic cement used as an ingredient of concrete and added to concrete before or during its mixing to modify its properties.

**AGGREGATE** is granular material, such as sand, gravel, crushed stone and iron blast-furnace slag, and when used with a cementing medium forms a hydraulic cement concrete or mortar.

**AGGREGATE, LIGHTWEIGHT**, is aggregate with a dry, loose weight of 70 pounds per cubic foot (pcf) (1120 kg/m<sup>3</sup>) or less.

**AIR-DRY WEIGHT** is the unit weight of a lightweight concrete specimen cured for seven days with neither loss nor gain of moisture at 60° F. to 80° F. (15.6° C. to 26.7° C.) and dried for 21 days in 50 ± 7 percent relative humidity at 73.4° F. ± 2° F. (23.0° C. ± 1.1 C.).

**ANCHORAGE** in posttensioning is a device used to anchor tendons to concrete member; in pretensioning, a device used to anchor tendons during hardening of concrete.

**BONDED TENDON** is a prestressing tendon that is bonded to concrete either directly or through grouting.

**CEMENTITIOUS MATERIALS** are materials as specified in Section 1903 which have cementing value when used in concrete either by themselves, such as portland cement or blended hydraulic cements, or in combination with fly ash, raw or other calcined natural pozzolans, or ground granulated blast-furnace slag.

**COLUMN** is a member with a ratio of height-to-least-lateral dimension of 3 or greater used primarily to support axial compressive load.

**COMPOSITE CONCRETE FLEXURAL MEMBERS** are concrete flexural members of precast and cast-in-place concrete elements or both constructed in separate placements but so interconnected that all elements respond to loads as a unit.

**CONCRETE** is a mixture of portland cement or any other hydraulic cement, fine aggregate, coarse aggregate and water, with or without admixtures.

**CONCRETE, SPECIFIED COMPRESSIVE STRENGTH OF ( $f'_c$ )**, is the compressive strength of concrete used in design and evaluated in accordance with provisions of Section 1905, expressed in pounds per square inch (psi) (MPa). Whenever the quantity  $f'_c$  is under a radical sign, square root of numerical value only is intended, and result has units of psi (MPa).

**CONCRETE, STRUCTURAL LIGHTWEIGHT**, is concrete containing lightweight aggregate having an air-dry unit weight as determined by definition above, not exceeding 115 pcf (1840 kg/m<sup>3</sup>). In this code, a lightweight concrete without natural sand is termed "all-lightweight concrete" and lightweight concrete in which all fine aggregate consists of normal-weight sand is termed "sand-lightweight concrete."

**CURVATURE FRICTION** is friction resulting from bends or curves in the specified prestressing tendon profile.

**DEFORMED REINFORCEMENT** is deformed reinforcing bars, bar and rod mats, deformed wire, welded smooth wire fabric and welded deformed wire fabric.

**DEVELOPMENT LENGTH** is the length of embedded reinforcement required to develop the design strength of reinforcement at a critical section. See Section 1909.3.3.

**EFFECTIVE DEPTH OF SECTION ( $d$ )** is the distance measured from extreme compression fiber to centroid of tension reinforcement.

**EFFECTIVE PRESTRESS** is the stress remaining in prestressing tendons after all losses have occurred, excluding effects of dead load and superimposed load.

**EMBEDMENT LENGTH** is the length of embedded reinforcement provided beyond a critical section.

**JACKING FORCE** is the temporary force exerted by device that introduces tension into prestressing tendons in prestressed concrete.

**LOAD, DEAD**, is the dead weight supported by a member, as defined by *Section 1602* (without load factors).

**LOAD, FACTORED**, is the load, multiplied by appropriate load factors, used to proportion members by the strength design method of this code. See Sections 1908.1.1 and 1909.2.

**LOAD, LIVE**, is the live load specified by *Section 1602* (without load factors).

**LOAD, SERVICE**, is the live and dead loads (without load factors).

**MODULUS OF ELASTICITY** is the ratio of normal stress to corresponding strain for tensile or compressive stresses below proportional limit of material. See Section 1908.5.

**PEDESTAL** is an upright compression member with a ratio of unsupported height to average least lateral dimension of 3 or less.

**PLAIN CONCRETE** is concrete that is either unreinforced or contains less reinforcement than the minimum amount specified in this code for reinforced concrete. See Section 1923.

**PLAIN REINFORCEMENT** is reinforcement that does not conform to definition of deformed reinforcement.

**POSTTENSIONING** is a method of prestressing in which tendons are tensioned after concrete has hardened.

**PRECAST CONCRETE** is plain or reinforced concrete element cast in other than its final position in the structure.

**PRESTRESSED CONCRETE** is reinforced concrete in which internal stresses have been introduced to reduce potential tensile stresses in concrete resulting from loads.

**PRETENSIONING** is a method of prestressing in which tendons are tensioned before concrete is placed.

**REINFORCED CONCRETE** is concrete reinforced with no less than the minimum amount required by this code, prestressed or nonprestressed, and designed on the assumption that the two materials act together in resisting forces.

**REINFORCEMENT** is material that conforms to Section 1903.5.1, excluding prestressing tendons unless specifically included.

**SPAN LENGTH.** See Section 1908.7.

**SPIRAL REINFORCEMENT** is continuously wound reinforcement in the form of a cylindrical helix.

**SPLITTING TENSILE STRENGTH** ( $f_{ct}$ ) is the tensile strength of concrete. See Section 1905.1.4, last paragraph.

**STIRRUP** is reinforcement used to resist shear and torsion stresses in a structural member; typically bars, wires, or welded wire fabric (smooth or deformed) bent into L, U or rectangular shapes and located perpendicular to or at an angle to longitudinal reinforcement. (The term "stirrups" is usually applied to lateral reinforcement in flexural members and the term "ties" to those in compression members.) See "tie."

**STRENGTH, DESIGN,** is the nominal strength multiplied by a strength-reduction factor  $\phi$ . See Section 1909.3.

**STRENGTH, NOMINAL,** is the strength of a member or cross section calculated in accordance with provisions and assumptions of the strength design method of this code before application of any strength-reduction factors. See Section 1909.3.1.

**STRENGTH, REQUIRED,** is the strength of a member or cross section required to resist factored loads or related internal moments and forces in such combinations as are stipulated in this code. See Section 1909.1.1.

**STRESS** is the intensity of force per unit area.

**TENDON** is a steel element such as wire, cable, bar, rod or strand, or a bundle of such elements, used to impart prestress to concrete.

**TIE** is a loop of reinforcing bar or wire enclosing longitudinal reinforcement. See "stirrup."

**TRANSFER** is the act of transferring stress in prestressing tendons from jacks or pretensioning bed to concrete member.

**WALL** is a member, usually vertical, used to enclose or separate spaces.

**WOBBLE FRICTION** in prestressed concrete, is friction caused by unintended deviation of prestressing sheath or duct from its specified profile.

**YIELD STRENGTH** is the specified minimum yield strength or yield point of reinforcement in psi.

## SECTION 1903 — SPECIFICATIONS FOR TESTS AND MATERIALS

### 1903.0 Notations.

$f_y$  = specified yield strength of nonprestressed reinforcement, psi (MPa).

### 1903.1 Tests of Materials.

**1903.1.1** The building official may require the testing of any materials used in concrete construction to determine if materials are of quality specified.

**1903.1.2** Tests of materials and of concrete shall be made *by an approved agency and at no expense to the jurisdiction. Such tests shall be made in accordance with the standards listed in Section 1903.*

**1903.1.3** A complete record of tests of materials and of concrete shall be available for inspection during progress of work and for two years after completion of the project, and shall be preserved by the inspecting engineer or architect for that purpose.

**1903.1.4 Material and test standards.** *The standards listed in this section labeled a "U.B.C. standard" are also listed in Chapter 35, Part II, and are part of this code. The other standards listed are recognized standards. (See Sections 3502 and 3503.)*

**1903.2 Cement.**

1. ASTM C 845, Expansive Hydraulic Cement
2. U.B.C. Standard 19-1, Portland Cement and Blended Hydraulic Cements

**1903.3 Aggregates.**

**1903.3.1 Recognized standards.**

1. ASTM C 33, Concrete Aggregates
2. ASTM C 330, Lightweight Aggregates for Structural Concrete
3. ASTM C 332, Lightweight Aggregates for Insulating Concrete
4. Aggregates failing to meet the above specifications but which have been shown by special test or actual service to produce concrete of adequate strength and durability may be used where authorized by the building official.

**1903.3.2** The nominal maximum size of coarse aggregate shall not be larger than:

1. One fifth the narrowest dimension between sides of forms, or
2. One third the depth of slabs, or
3. Three fourths the minimum clear spacing between individual reinforcing bars or wires, bundles of bars, or prestressing tendons or ducts.

These limitations may be waived if, in the judgment of the *building official*, workability and methods of consolidation are such that concrete can be placed without honeycomb or voids.

**1903.4 Water.**

**1903.4.1** Water used in mixing concrete shall be clean and free from injurious amounts of oils, acids, alkalis, salts, organic materials or other substances that may be deleterious to concrete or reinforcement.

**1903.4.2** Mixing water for prestressed concrete or for concrete that will contain aluminum embedments, including that portion of mixing water contributed in the form of free moisture on aggregates, shall not contain deleterious amounts of chloride ions. See Section 1904.4.1.

**1903.4.3** Nonpotable water shall not be used in concrete unless the following are satisfied:

**1903.4.3.1** Selection of concrete proportions shall be based on concrete mixes using water from the same source.

**1903.4.3.2** Mortar test cubes made with nonpotable mixing water shall have seven-day and 28-day strengths equal to at least 90 percent of strengths of similar specimens made with potable water. Strength test comparison shall be made on mortars, identical except for the mixing water, prepared and tested in accordance with *approved standards*.

**1903.5 Metal Reinforcement.**

**1903.5.1** Reinforcement shall be deformed reinforcement, except that plain reinforcement may be used for spirals or tendons, and reinforcement consisting of structural steel, steel pipe or steel tubing may be used as specified in this chapter.

**1903.5.2** Reinforcing bars to be welded shall be indicated on the drawings and welding procedure to be used shall be specified. *Steel specifications*, except for A 706, shall be supplemented to require a report of material properties necessary to conform to welding procedures specified in *U.B.C. Standard 19-2*.

### **1903.5.3 Deformed reinforcements.**

**1903.5.3.1** ASTM A 615, A 616, A 617, A 706, A 767 and A 775, Reinforcing Bars for Concrete.

**1903.5.3.2** Deformed reinforcing bars with a specified yield strength  $f_y$  exceeding 60,000 psi (413.7 MPa) may be used, provided  $f_y$  shall be the stress corresponding to a strain of 0.35 percent and the bars otherwise conform to approved national standards, see *ASTM A 615, A 616, A 617, A 706, A 767 and A 775*. See Section 1909.4.

**1903.5.3.3** ASTM A 184, Fabricated Deformed Steel Bar Mats. For reinforced bars used in bar mats, see ASTM A 615, A 616, A 617, A 706, A 767 or A 775.

**1903.5.3.4** ASTM A 496, Steel Wire, Deformed, for Concrete Reinforcement. For deformed reinforcing wire, see ASTM A 615, A 616, A 617, A 706, A 767 or A 775.

For deformed wire for concrete reinforcement, see *ASTM A 496*, except that wire shall not be smaller than size D4, and for wire with a specified yield strength  $f_y$  exceeding 60,000 psi (413.7 MPa),  $f_y$  shall be the stress corresponding to a strain of 0.35 percent, if the yield strength specified in design exceeds 60,000 psi (413.7 MPa).

**1903.5.3.5** ASTM A 185, Steel Welded Wire, Fabric, Plain for Concrete Reinforcement. For welded plain steel wire fabric, see ASTM A 615, A 616, A 617, A 706, A 767 or A 775.

For welded plain wire fabric for concrete reinforcement, see *ASTM 185*, except that for wire with a specified yield strength  $f_y$  exceeding 60,000 psi (413.7 MPa),  $f_y$  shall be the stress corresponding to a strain of 0.35 percent, if the yield strength specified in design exceeds 60,000 psi (413.7 MPa). Welded intersections shall not be spaced farther apart than 12 inches (305 mm) in direction of calculated stress, except for wire fabric used as stirrups in accordance with Section 1912.14.

**1903.5.3.6** ASTM A 497, Welded Deformed Steel Wire Fabric for Concrete Reinforcement. For welded deformed steel wire fabric, see ASTM A 615, A 616, A 617, A 706, A 767 or A 775.

For welded deformed wire fabric for concrete reinforcement, see *ASTM A 497*, except that for wire with a specified yield strength  $f_y$  exceeding 60,000 psi (413.7 MPa),  $f_y$  shall be the stress corresponding to a strain of 0.35 percent, if the yield strength specified in design exceeds 60,000 psi (413.7 MPa). Welded intersections shall not be spaced farther apart than 16 inches (406 mm) in direction of calculated stress, except for wire fabric used as stirrups in accordance with Section 1912.13.

**1903.5.3.7** Deformed reinforcing bars may be galvanized or epoxy coated. For zinc or epoxy-coated reinforcement, see ASTM A 615, A 616, A 617, A 706, A 767 and A 775.

### **1903.5.4 Plain reinforcement.**

**1903.5.4.1** Plain bars for spiral reinforcement shall conform to approved national standards, see *ASTM A 615, A 616 and A 617*.

**1903.5.4.2** For plain wire for spiral reinforcement, see *ASTM A 82* except that for wire with a specified yield strength  $f_y$  exceeding 60,000 psi (413.7 MPa),  $f_y$  shall be the stress corresponding to a strain of 0.35 percent, if the yield strength specified in design exceeds 60,000 psi (413.7 MPa).

### **1903.5.5 Prestressing tendons.**

**1903.5.5.1** 1. ASTM A 416, Uncoated Seven-wire Stress-relieved Steel Strand for Prestressed Concrete

2. ASTM A 421, Uncoated Stress-relieved Wire for Prestressed Concrete
3. ASTM A 722, Uncoated High-strength Steel Bar for Prestressing Concrete

**1903.5.5.2** Wire, strands and bars not specifically listed in *ASTM A 416, A 421 and A 722* may be used, provided they conform to minimum requirements of these specifications and do not have properties that make them less satisfactory than those listed.

**1903.5.6 Structural steel, steel pipe or tubing.**

**1903.5.6.1** For structural steel used with reinforcing bars in composite compression members meeting requirements of Section 1910.14.7 or 1910.14.8, see *ASTM A 36, A 242, A 572 and A 588*.

**1903.5.6.2** For steel pipe or tubing for composite compression members composed of a steel-encased concrete core meeting requirements of Section 1910.14.4, see *ASTM A 53, A 500 and A 501*.

**1903.5.7** *U.B.C. Standard 19-2, Welding Reinforcing Steel, Metal Inserts and Connections in Reinforced Concrete Construction*

**1903.6 Admixtures.**

**1903.6.1** Admixtures to be used in concrete shall be subject to prior approval by the *building official*.

**1903.6.2** An admixture shall be shown capable of maintaining essentially the same composition and performance throughout the work as the product used in establishing concrete proportions in accordance with Section 1905.2.

**1903.6.3** Calcium chloride or admixtures containing chloride from other than impurities from admixture ingredients shall not be used in prestressed concrete, in concrete containing embedded aluminum, or in concrete cast against stay-in-place galvanized metal forms. See Sections 1904.3.2 and 1904.4.1.

**1903.6.4** ASTM C 260, Air-entraining Admixtures for Concrete

**1903.6.5** ASTM C 494 and C 1017, Chemical Admixtures for Concrete

**1903.6.6** ASTM C 618, Fly Ash and Raw or Calcined Natural Pozzolans for Use as Admixtures in Portland Cement Concrete

**1903.6.7** *U.B.C. Standard 19-6, Ground-iron Blast-furnace Slag for Use in Concrete and Mortars*

**1903.7 Storage of Materials.** Cementitious materials and aggregate shall be stored in such manner as to prevent deterioration or intrusion of foreign matter. Any material that has deteriorated or has been contaminated shall not be used for concrete.

**1903.8 Concrete Testing.**

1. ASTM C 192, Making and Curing Concrete Test Specimens in the Laboratory
2. ASTM C 31, Making and Curing Concrete Test Specimens in the Field
3. ASTM C 42, Obtaining and Testing Drilled Cores and Sawed Beams of Concrete
4. ASTM C 39, Compressive Tests
5. ASTM C 172, Sampling Fresh Concrete
6. ASTM C 496, Splitting Tensile Strength
7. *U.B.C. Standard 19-7, Slump of Portland Cement Concrete*

**1903.9 Concrete Mix.**

1. *U.B.C. Standard 19-3, Ready-mixed Concrete*

2. *U.B.C. Standard 19-4, Concrete Made for Volumetric Batching and Continuous Mixing*
3. *U.B.C. Standard 19-5, Mill-mixed Gypsum Concrete and Poured Gypsum Roof Diaphragms*

1903.10 *Welding. The welding of reinforcing steel, metal inserts and connections in reinforced concrete construction shall conform to U.B.C. Standard 19-2.*

## SECTION 1904 — DURABILITY REQUIREMENTS

### 1904.0 Notation.

$f'_c$  = specified compressive strength of concrete, psi (MPa).

### 1904.1 Water-Cementitious Materials Ratio.

1904.1.1 The water-cementitious materials ratios specified in Tables 19-A-2 and 19-A-3 shall be calculated using the weight of cement plus the weight of fly ash and pozzolans and slag, if any.

### 1904.2 Freezing and Thawing Exposures.

1904.2.1 Normal-weight and lightweight concrete exposed to freezing and thawing or deicing chemicals shall be air entrained with air content indicated in Table 19-A-1. Tolerance on air content as delivered shall be  $\pm 1.5$  percent. For specified compressive strength  $f'_c$  greater than 5,000 psi (34.47 MPa), air content indicated in Table 19-A-1 may be reduced by 1 percent.

1904.2.2 Concrete that will be subjected to the exposures given in Table 19-A-2 shall conform to the corresponding maximum water-cementitious materials ratios and minimum specified concrete compressive strength requirements of that table. In addition, concrete that will be exposed to deicing chemicals shall conform to the limitations of Section 1904.2.3.

1904.2.3 For concrete exposed to deicing chemicals, the maximum weight of fly ash, other pozzolans or slag that is included in the calculation of water-cementitious materials ratio shall not exceed the following percentages of the total weight of portland cement plus fly ash, other pozzolans and slag.

1904.2.3.1 The combined weight of fly ash and other pozzolans shall not exceed 25 percent of the total weight of cementitious materials. The fly ash and other pozzolans present in a Type IP or IPM blended cement shall be included in the calculated percentage.

1904.2.3.2 The weight of slag shall not exceed 50 percent of the total weight of cementitious materials. The slag used in the manufacture of Type IP or IPM blended hydraulic cement shall be included in the calculated percentage.

1904.2.3.3 If fly ash or other pozzolans are used in concrete with slag, the portland cement constituent shall not be less than 50 percent of the total weight of cementitious materials. Fly ash or other pozzolans shall constitute no more than 25 percent of the total weight of cementitious materials.

### 1904.3 Sulfate Exposure.

1904.3.1 Concrete to be exposed to sulfate-containing solutions or soils shall conform to the requirements of Table 19-A-3 or shall be concrete made with a cement that provides sulfate resistance and that has a maximum water-cementitious materials ratio and minimum compressive strength set forth in Table 19-A-3.

1904.3.2 Calcium chloride as an admixture shall not be used in concrete to be exposed to severe or very severe sulfate-containing solutions, as defined in Table 19-A-3.

### 1904.4 Corrosion Protection of Reinforcement.

1904.4.1 For corrosion protection, maximum water soluble chloride ion concentrations in hardened concrete at ages from 28 to 42 days contributed from the ingredients, including water, aggregates, cementitious materials and admixtures shall not exceed the limits of Table 19-A-4.

**1904.4.2** When reinforced concrete will be exposed to deicing salts, brackish water, sea water or spray from these sources, requirements of Table 19-A-2 for water-cementitious materials ratio and concrete strength and the minimum concrete cover requirements of Section 1907.7 shall be satisfied.

## SECTION 1905 — CONCRETE QUALITY, MIXING AND PLACING

### 1905.0 Notations.

$f'_c$  = specified compressive strength of concrete, psi (MPa).

$f'_{cr}$  = required average compressive strength of concrete used as the basis for selection of concrete proportions, psi (MPa).

$f_{ct}$  = average splitting tensile strength of lightweight aggregate concrete, psi (MPa).

$s$  = standard deviation, psi (MPa).

### 1905.1 General.

**1905.1.1** Concrete shall be proportioned to provide an average compressive strength as prescribed in Section 1905.3.2, as well as satisfy the durability criteria of Section 1904. Concrete shall be produced to minimize frequency of strengths below  $f'_c$  as prescribed in Section 1905.6.3.

**1905.1.2** Requirements for  $f'_c$  shall be based on tests of cylinders made and tested as prescribed in Section 1905.6.2.

**1905.1.3** Unless otherwise specified,  $f'_c$  shall be based on 28-day tests. If other than 28 days, test age for  $f'_c$  shall be as indicated in design drawings or specifications.

*Design drawings shall show specified compressive strength of concrete  $f'_c$  for which each part of structure is designed.*

**1905.1.4** Where design criteria in Sections 1909.5.2.3, 1911.2; and 1912.2.4.2, provide for use of a splitting tensile strength value of concrete, laboratory tests shall be made to establish value of  $f_{ct}$  corresponding to specified values of  $f'_c$ .

**1905.1.5** Splitting tensile strength tests shall not be used as a basis for field acceptance of concrete.

### 1905.2 Selection of Concrete Proportions.

**1905.2.1** Proportions of materials for concrete shall be established to provide:

1. Workability and consistency to permit concrete to be worked readily into forms and around reinforcement under conditions of placement to be employed without segregation or excessive bleeding.

2. Resistance to special exposures as required by Section 1904.

3. Conformance with strength test requirements of Section 1905.6.

**1905.2.2** Where different materials are to be used for different portions of proposed work, each combination shall be evaluated.

**1905.2.3** Concrete proportions, including water-cementitious materials ratio, shall be established on the basis of field experience and/or trial mixtures with materials to be employed, except as permitted in Section 1905.4 or required by Section 1904.

### 1905.3 Proportioning on the Basis of Field Experience and Trial Mixtures.

#### 1905.3.1 Standard deviation.

**1905.3.1.1** Where a concrete production facility has test records, a standard deviation shall be established. Test records from which a standard deviation is calculated:

1. Must represent materials, quality control procedures and conditions similar to those expected, and changes in materials and proportions within the test records shall not have been more restricted than those for proposed work.

2. Must represent concrete produced to meet a specified strength or strengths  $f'_c$  within 1,000 psi (6.89 MPa) of that specified for proposed work.

3. Must consist of at least 30 consecutive tests or two groups of consecutive tests totaling at least 30 tests as defined in Section 1905.6.1.4, except as provided in Section 1905.3.1.2.

**1905.3.1.2** Where a concrete production facility does not have test records meeting requirements of Section 1905.3.1.1, but does have a record based on 15 to 29 consecutive tests, a standard deviation may be established as the product of the calculated standard deviation and the modification factor of Table 19-A-5. To be acceptable, the test record must meet the requirements of Section 1905.3.1.1, Items 1 and 2, and represent only a single record of consecutive tests that span a period of not less than 45 calendar days.

**1905.3.2 Required average strength.**

**1905.3.2.1** Required average compressive strength  $f'_{cr}$  used as the basis for selection of concrete proportions shall be the larger of Formula (5-1) or (5-2) using a standard deviation calculated in accordance with Section 1905.3.1.1 or 1905.3.1.2.

$$f'_{cr} = f'_c + 1.34s \quad (5-1)$$

or

$$f'_{cr} = f'_c + 2.33s - 500 \quad (5-2)$$

For SI:

$$f'_{cr} = f'_c + 2.33s - 3.45$$

**1905.3.2.2** When a concrete production facility does not have field strength test records for calculation of standard deviation meeting requirements of Section 1905.3.1.1 or 1905.3.1.2, required average strength  $f'_{cr}$  shall be determined from Table 19-A-6 and documentation of average strength shall be in accordance with requirements of Section 1905.3.3.

**1905.3.3 Documentation of average strength.** Documentation that proposed concrete proportions will produce an average compressive strength equal to or greater than required average compressive strength may consist of a field strength test record, several strength test records, or trial mixtures.

**1905.3.3.1** When test records are used to demonstrate that proposed concrete proportions will produce the required average strength  $f'_{cr}$ , such records shall represent materials and conditions similar to those expected. Changes in materials, conditions and proportions within the test records shall not have been more restricted than those for proposed work. For the purpose of documenting average strength potential, test records consisting of less than 30 but not less than 10 consecutive tests may be used, provided test records encompass a period of time not less than 45 days. Required concrete proportions may be established by interpolation between the strengths and proportions of two or more test records each of which meets other requirements of this section.

**1905.3.3.2** When an acceptable record of field test results is not available, concrete proportions may be established based on trial mixtures meeting the following restrictions:

1. Combination of materials shall be those for proposed work.
2. Trial mixtures having proportions and consistencies required for proposed work shall be made using at least three different water-cementitious materials ratios or cementitious materials contents that will produce a range of strengths encompassing the required average strength  $f'_{cr}$ .

3. Trial mixture shall be designed to produce a slump within  $\pm 0.75$  inch ( $\pm 19$  mm) of maximum permitted, and for air-entrained concrete, within  $\pm 0.5$  percent of maximum allowable air content.
4. For each water-cementitious materials ratio or cementitious materials content, at least three test cylinders for each test age shall be made and cured. Cylinders shall be tested at 28 days or at test age designated for determination of  $f'_c$ .
5. From results of cylinder tests, a curve shall be plotted showing relationship between water-cementitious materials ratio or cementitious materials content and compressive strength at designated test age.
6. Maximum water-cementitious materials ratio or minimum cementitious materials content for concrete to be used in proposed work shall be that shown by the curve to produce the average strength required by Section 1905.3.2, unless a lower water-cementitious materials ratio or higher strength is required by Section 1904.

#### 1905.4 Proportioning by Water-Cementitious Materials Ratio.

**1905.4.1** If data required by Section 1905.3 are not available, concrete proportions shall be based on water-cementitious materials ratio limits in Table 19-A-7, if approved by the building official.

**1905.4.2** Table 19-A-7 shall be used only for concrete to be made with cements meeting strength requirements for Type I, I-A, II, II-A, III, III-A or V; or Type IS, IS-A, IS(MS), IS-A(MS), I(SM), I(SM)-A, IP, IP-A, I(PM), I(PM)-A, IP(MS), IP-A(MS), or P of U.B.C. Standard 19-1, and shall not be applied to concrete containing lightweight aggregates or admixtures other than those for entraining air.

**1905.4.3** Concrete proportioned by water-cementitious materials ratio limits prescribed in Table 19-A-7 shall also conform to special exposure requirements of Section 1904 and to compressive strength test criteria of Section 1905.6.

**1905.5 Average Strength Reduction.** As data become available during construction, amount by which value of  $f'_{cr}$  must exceed specified value of  $f'_c$  may be reduced, provided:

1. Thirty or more test results are available and average of test results exceeds that required by Section 1905.3.2.1, using a standard deviation calculated in accordance with Section 1905.3.1.1, or
2. Fifteen to 29 test results are available and average of test results exceeds that required by Section 1905.3.2.1, using a standard deviation calculated in accordance with Section 1905.3.1.1, and
3. Special exposure requirements of Section 1904 are met.

#### 1905.6 Evaluation and Acceptance of Concrete.

##### 1905.6.1 Frequency of testing.

**1905.6.1.1** Samples for strength tests of each class of concrete placed each day shall be taken not less than once a day, or not less than once for each 150 cubic yards (115 m<sup>3</sup>) of concrete, or not less than once for each 5,000 square feet (465 m<sup>2</sup>) of surface area for slabs or walls.

**1905.6.1.2** On a given project, if the total volume of concrete is such that the frequency of testing required by Section 1905.6.1.1 above would provide less than five strength tests for a given class of concrete, tests shall be made from at least five randomly selected batches or from each batch if fewer than five batches are used.

**1905.6.1.3** When total quantity of a given class of concrete is less than 50 cubic yards (38 m<sup>3</sup>), strength tests are not required when evidence of satisfactory strength is submitted to and approved by the building official.

**1905.6.1.4** A strength test shall be the average of the strengths of two cylinders made from the same sample of concrete and tested at 28 days or at test age designated for determination of  $f'_c$ .

**1905.6.2 Laboratory-cured specimens.**

**1905.6.2.1** Samples for strength tests shall be taken.

■ **1905.6.2.2** Cylinders for strength tests shall be molded and laboratory cured and tested.

**1905.6.2.3** Strength level of an individual class of concrete shall be considered satisfactory if both the following requirements are met:

1. Average of all sets of three consecutive strength tests equal or exceed  $f'_c$ .
2. No individual strength test (average of two cylinders) falls below  $f'_c$  by more than 500 psi (3.45 MPa).

**1905.6.2.4** If either of the requirements of Section 1905.6.2.3 are not met, steps shall be taken to increase the average of subsequent strength test results. Requirements of Section 1905.6.4 shall be observed if the requirement of Item 2 of Section 1905.6.2.3 is not met.

**1905.6.3 Field-cured specimens.**

**1905.6.3.1** The building official may require strength tests of cylinders cured under field conditions to check adequacy of curing and protection of concrete in the structure.

■ **1905.6.3.2** Field-cured cylinders shall be cured under field conditions, in accordance with Section 1903.8.

**1905.6.3.3** Field-cured test cylinders shall be molded at the same time and from the same samples as laboratory-cured test cylinders.

**1905.6.3.4** Procedures for protecting and curing concrete shall be improved when strength of field-cured cylinders at test age designated for determination of  $f'_c$  is less than 85 percent of that of companion laboratory-cured cylinders. The 85 percent limitation shall not apply if field-cured strength exceeds  $f'_c$  by more than 500 psi (3.45 MPa).

**1905.6.4 Investigation of low-strength test results.**

**1905.6.4.1** If any strength test of laboratory-cured cylinders falls below specified value of  $f'_c$  by more than 500 psi (3.45 MPa) or if tests of field-cured cylinders indicate deficiencies in protection and curing, steps shall be taken to assure that load-carrying capacity of the structure is not jeopardized.

**1905.6.4.2** If the likelihood of low-strength concrete is confirmed and computations indicate that load-carrying capacity may have been significantly reduced, tests of cores drilled from the area in question may be required. In such case, three cores shall be taken for each strength test more than 500 psi (3.45 MPa) below specified value of  $f'_c$ .

**1905.6.4.3** If concrete in the structure will be dry under service conditions, cores shall be air dried [temperatures 60°F. to 80°F. (15.6°C. to 26.7°C.), relative humidity less than 60 percent] for seven days before test and shall be tested dry. If concrete in the structure will be more than superficially wet under service conditions, cores shall be immersed in water for at least 40 hours and be tested wet.

**1905.6.4.4** Concrete in an area represented by core tests shall be considered structurally adequate if the average of three cores is equal to at least 85 percent of  $f'_c$  and if no single core is less than 75 percent of  $f'_c$ . Additional testing of cores extracted from locations represented by erratic core strength results shall be permitted.

**1905.6.4.5** If criteria of Section 1905.6.4, Item 4, are not met, and if structural adequacy remains in doubt, the responsible authority may order load tests as outlined in Section 1920 for the questionable portion of the structure, or take other appropriate action.

**1905.7 Preparation of Equipment and Place of Deposit.**

**1905.7.1** Preparation before concrete placement shall include the following:

1. All equipment for mixing and transporting concrete shall be clean.
2. All debris and ice shall be removed from spaces to be occupied by concrete.
3. Forms shall be properly coated.
4. Masonry filler units that will be in contact with concrete shall be well drenched.
5. Reinforcement shall be thoroughly clean of ice or other deleterious coatings.
6. Water shall be removed from place of deposit before concrete is placed unless a tremie is to be used or unless otherwise permitted by the building official.
7. All laitance and other unsound material shall be removed before additional concrete is placed against hardened concrete.

**1905.8 Mixing.**

**1905.8.1** All concrete shall be mixed until there is a uniform distribution of materials and shall be discharged completely before mixer is recharged.

**1905.8.2** Ready-mixed concrete shall be mixed and delivered in accordance with requirements of *U.B.C. Standard 19-3*.

*Concrete made by the on-site volumetric batching and continuous mixing procedure shall be mixed and delivered in accordance with requirements of U.B.C. Standard 19-4.*

**1905.8.3** Job-mixed concrete shall be mixed in accordance with the following:

1. Mixing shall be done in a batch mixer of an approved type.
2. Mixer shall be rotated at a speed recommended by the manufacturer.
3. Mixing shall be continued for at least 1½ minutes after all materials are in the drum, unless a shorter time is shown to be satisfactory by the mixing uniformity tests of *U.B.C. Standard 19-3*.
4. Materials handling, batching and mixing shall conform to applicable provisions of *U.B.C. Standard 19-3*.
5. A detailed record shall be kept to identify:
  - 5.1 Number of batches produced;
  - 5.2 Proportions of materials used;
  - 5.3 Approximate location of final deposit in structure;
  - 5.4 Time and date of mixing and placing.

**1905.9 Conveying.**

**1905.9.1** Concrete shall be conveyed from mixer to place of final deposit by methods that will prevent separation or loss of materials.

**1905.9.2** Conveying equipment shall be capable of providing a supply of concrete at site of placement without separation of ingredients and without interruptions sufficient to permit loss of plasticity between successive increments.

**1905.10 Depositing.**

**1905.10.1** Concrete shall be deposited as nearly as practicable in its final position to avoid segregation due to rehandling or flowing.

**1905.10.2** Concreting shall be carried on at such a rate that concrete is at all times plastic and flows readily into spaces between reinforcement.

**1905.10.3** Concrete that has partially hardened or been contaminated by foreign materials shall not be deposited in the structure.

**1905.10.4** Retempered concrete or concrete that has been remixed after initial set shall not be used unless approved by the *building official*.

**1905.10.5** After concreting is started, it shall be carried on as a continuous operation until placing of a panel or section, as defined by its boundaries or predetermined joints, is completed, except as permitted or prohibited by Section 1906.4.

**1905.10.6** Top surfaces of vertically formed lifts shall be generally level.

**1905.10.7** When construction joints are required, joints shall be made in accordance with Section 1906.4.

**1905.10.8** All concrete shall be thoroughly consolidated by suitable means during placement and shall be thoroughly worked around reinforcement and embedded fixtures and into corners of forms.

### **1905.11 Curing.**

**1905.11.1** Concrete (other than high-early-strength) shall be maintained above 50°F. (10.0°C.) and in a moist condition for at least the first seven days after placement, except when cured in accordance with Section 1905.11.3.

**1905.11.2** High-early-strength concrete shall be maintained above 50°F. (10.0°C.) and in a moist condition for at least the first three days, except when cured in accordance with Section 1905.11.3.

#### **1905.11.3 Accelerated curing.**

**1905.11.3.1** Curing by high-pressure steam, steam at atmospheric pressure, heat and moisture or other accepted processes, may be employed to accelerate strength gain and reduce time of curing.

**1905.11.3.2** Accelerated curing shall provide a compressive strength of the concrete at the load stage considered at least equal to required design strength at that load stage.

**1905.11.3.3** Curing process shall be such as to produce concrete with a durability at least equivalent to the curing method of Section 1905.11.1 or 1905.11.2.

**1905.11.3.4** When required by the building official, supplementary strength tests in accordance with Section 1905.6.3 shall be performed to assure that curing is satisfactory.

### **1905.12 Cold Weather Requirements.**

**1905.12.1** Adequate equipment shall be provided for heating concrete materials and protecting concrete during freezing or near-freezing weather. All concrete materials and all reinforcement, forms, fillers and ground with which concrete is to come in contact shall be free from frost.

**1905.12.2** Frozen materials or materials containing ice shall not be used.

**1905.13 Hot Weather Requirements.** During hot weather, proper attention shall be given to ingredients, production methods, handling, placing, protection and curing to prevent excessive concrete temperatures or water evaporation that may impair required strength or serviceability of the member or structure.

## **SECTION 1906 — FORMWORK, EMBEDDED PIPES AND CONSTRUCTION JOINTS**

### **1906.1 Design of Formwork.**

**1906.1.1** Forms shall result in a final structure that conforms to shapes, lines and dimensions of the members as required by the design drawings and specifications.

**1906.1.2** Forms shall be substantial and sufficiently tight to prevent leakage of mortar.

**1906.1.3** Forms shall be properly braced or tied together to maintain position and shape.

**1906.1.4** Forms and their supports shall be designed so as not to damage previously placed structure.

**1906.1.5** Design of formwork shall include consideration of the following factors:

1. Rate and method of placing concrete.
2. Construction loads, including vertical, horizontal and impact loads.
3. Special form requirements for construction of shells, folded plates, domes, architectural concrete or similar types of elements.

**1906.1.6** Forms for prestressed concrete members shall be designed and constructed to permit movement of the member without damage during application of prestressing force.

### **1906.2 Removal of Forms and Shores.**

**1906.2.1** Construction loads shall not be supported on, or any shoring removed from, any part of the structure under construction except when that portion of the structure in combination with remaining forming and shoring system has sufficient strength to support safely its weight and loads placed thereon.

**1906.2.1.1** Sufficient strength shall be demonstrated by structural analysis considering proposed loads, strength of forming and shoring system and concrete strength data. Concrete strength data may be based on tests of field-cured cylinders or, when approved by the building official, on other procedures to evaluate concrete strength. Structural analysis and concrete strength test data shall be furnished to the building official when so required.

**1906.2.2** Construction loads exceeding the combination of superimposed dead load plus specified live load shall not be supported on any unshored portion of the structure under construction, unless analysis indicates adequate strength to support such additional loads.

**1906.2.3** Forms shall be removed in such manner as not to impair safety and serviceability of the structure. All concrete to be exposed by form removal shall have sufficient strength not to be damaged thereby.

**1906.2.4** Form supports for prestressed concrete members may be removed when sufficient prestressing has been applied to enable prestressed members to carry their dead load and anticipated construction loads.

### **1906.3 Conduits and Pipes Embedded in Concrete.**

**1906.3.1** Conduits, pipes and sleeves of any material not harmful to concrete and within limitations of this subsection may be embedded in concrete with approval of the *building official*, provided they are not considered to replace structurally the displaced concrete.

**1906.3.2** Conduits and pipes of aluminum shall not be embedded in structural concrete unless effectively coated or covered to prevent aluminum-concrete reaction or electrolytic action between aluminum and steel.

**1906.3.3** Conduits, pipes and sleeves passing through a slab, wall or beam shall not impair significantly the strength of the construction.

**1906.3.4** Conduits and pipes, with their fittings, embedded within a column shall not displace more than 4 percent of the area of cross section on which strength is calculated or which is required for fire protection.

**1906.3.5** Except when plans for conduits and pipes are approved by the *building official*, conduits and pipes embedded within a slab, wall or beam (other than those merely passing through) shall satisfy the following:

**1906.3.5.1** They shall not be larger in outside dimension than one third the overall thickness of slab, wall or beam in which they are embedded.

**1906.3.5.2** They shall be spaced not closer than three diameters or widths on center.

**1906.3.5.3** They shall not impair significantly the strength of the construction.

**1906.3.6** Conduits, pipes and sleeves may be considered as replacing structurally in compression the displaced concrete, provided:

**1906.3.6.1** They are not exposed to rusting or other deterioration.

**1906.3.6.2** They are of uncoated or galvanized iron or steel not thinner than standard Schedule 40 steel pipe.

**1906.3.6.3** They have a nominal inside diameter not over 2 inches (51 mm) and are spaced not less than three diameters on centers.

**1906.3.7** Pipes and fittings shall be designed to resist effects of the material, pressure and temperature to which they will be subjected.

**1906.3.8** No liquid, gas or vapor, except water not exceeding 90°F. (32.2°C.) or 50 psi (0.34 MPa) pressure, shall be placed in the pipes until the concrete has attained its design strength.

**1906.3.9** In all solid slabs, piping, unless it is used for radiant heating or snow melting, shall be placed between top and bottom reinforcement.

**1906.3.10** Concrete cover for pipes, conduit and fittings shall not be less than 1½ inches (38 mm) for concrete exposed to earth or weather, or less than ¾ inch (19 mm) for concrete not exposed to weather or in contact with ground.

**1906.3.11** Reinforcement with an area not less than 0.002 times the area of concrete section shall be provided normal to the piping.

**1906.3.12** Piping and conduit shall be so fabricated and installed that cutting, bending or displacement of reinforcement from its proper location will not be required.

#### **1906.4 Construction Joints.**

**1906.4.1** Surface of concrete construction joints shall be cleaned and laitance removed.

**1906.4.2** Immediately before new concrete is placed, all construction joints shall be wetted and standing water removed.

**1906.4.3** Construction joints shall be so made and located as not to impair the strength of the structure. Provision shall be made for transfer of shear and other forces through construction joints. See Section 1911.7.9.

**1906.4.4** Construction joints in floors shall be located within the middle third of spans of slabs, beams and girders. Joints in girders shall be offset a minimum distance of two times the width of intersecting beams.

**1906.4.5** Beams, girders or slabs supported by columns or walls shall not be cast or erected until concrete in the vertical support members is no longer plastic.

**1906.4.6** Beams, girders, haunches, drop panels and capitals shall be placed monolithically as part of a slab system, unless otherwise shown in design drawings or specifications.

### **SECTION 1907 — DETAILS OF REINFORCEMENT**

#### **1907.0 Notations.**

$d$  = distance from extreme compression fiber to centroid of tension reinforcement, inches (mm).

$d_b$  = nominal diameter of bar, wire or prestressing strand, inches (mm).

$f_y$  = specified yield strength of nonprestressed reinforcement, psi (MPa).

$l_d$  = development length, inches (mm). See Section 1912.

**1907.1 Standard Hooks.** “Standard hook” as used in this code is one of the following:

**1907.1.1** One-hundred-eighty-degree bend plus  $4d_b$  extension, but not less than  $2\frac{1}{2}$  inches (64 mm) at free end of bar.

**1907.1.2** Ninety-degree bend plus  $12d_b$  extension at free end of bar.

**1907.1.3** For stirrup and tie hooks:

1. No. 5 bar and smaller, 90-degree bend plus  $6d_b$  extension at free end of bar, or
2. No. 6, No. 7 and No. 8 bar, 90-degree bend, plus  $12d_b$  extension at free end of bar, or
3. No. 8 bar and smaller, 135-degree bend plus  $6d_b$  extension at free end of bar.
4. For stirrup and tie hooks in Seismic Zones 3 and 4, refer to the hoop and crosstie provisions of Section 1921.1 and the transverse reinforcement.

**1907.2 Minimum Bend Diameters.**

**1907.2.1** Diameter of bend measured on the inside of the bar, other than for stirrups and ties in sizes No. 3 through No. 5, shall not be less than the values in Table 19-B.

**1907.2.2** Inside diameter of bends for stirrups and ties shall not be less than  $4d_b$  for No. 5 bar and smaller. For bars larger than No. 5, diameter of bend shall be in accordance with Table 19-B.

**1907.2.3** Inside diameter of bends in welded wire fabric (plain or deformed) for stirrups and ties shall not be less than  $4d_b$  for deformed wire larger than D6 and  $2d_b$  for all other wires. Bends with inside diameter of less than  $8d_b$  shall not be less than  $4d_b$  from nearest welded intersection.

**1907.3 Bending.**

**1907.3.1** All reinforcement shall be bent cold, unless otherwise permitted by the *building official*.

**1907.3.2** Reinforcement partially embedded in concrete shall not be field bent, except as shown on the design drawings or permitted by the *building official*.

**1907.4 Surface Conditions of Reinforcement.**

**1907.4.1** At the time concrete is placed, metal reinforcement shall be free from mud, oil or other nonmetallic coatings that decrease bond.

**1907.4.2** Metal reinforcement, except prestressing tendons, with rust, mill scale or a combination of both, shall be considered satisfactory, provided the minimum dimensions (including height of deformations) and weight of a hand-wire-brushed test specimen are not less than applicable specification requirements.

**1907.4.3** Prestressing tendons shall be clean and free of oil, dirt, scale, pitting and excessive rust. A light oxide is permissible.

**1907.5 Placing Reinforcement.**

**1907.5.1** Reinforcement, prestressing tendons and ducts shall be accurately placed and adequately supported before concrete is placed, and shall be secured against displacement within tolerances of this section.

**1907.5.2** Unless otherwise *approved by the building official*, reinforcement, prestressing tendons and prestressing ducts shall be placed within the following tolerances:

**1907.5.2.1** Tolerance for depth  $d$ , and minimum concrete cover in flexural members, walls and compression members shall be as follows:

	TOLERANCE ON $d$	TOLERANCE ON MINIMUM CONCRETE COVER
$d \leq 8$ in. (203 mm)	$\pm \frac{3}{8}$ in. (9.5 mm)	$-\frac{3}{8}$ in. (9.5 mm)
$d > 8$ in. (203 mm)	$\pm \frac{1}{2}$ in. (13 mm)	$-\frac{1}{2}$ in. (13 mm)

except that tolerance for the clear distance to formed soffits shall be minus  $\frac{1}{4}$  inch (6.4 mm) and tolerance for cover shall not exceed minus one third the minimum concrete cover required by the approved plans or specifications.

**1907.5.2.2** Tolerance for longitudinal location of bends and ends of reinforcement shall be  $\pm 2$  inches ( $\pm 51$  mm) except at discontinuous ends of members where tolerance shall be  $\pm \frac{1}{2}$  inch ( $\pm 13$  mm).

**1907.5.3** Welded wire fabric (with wire size not greater than W5 or D5) used in slabs not exceeding 10 feet (3048 mm) in span may be curved from a point near the top of slab over the support to a point near the bottom of slab at midspan, provided such reinforcement is either continuous over, or securely anchored at, support.

**1907.5.4** Welding of crossing bars shall not be permitted for assembly of reinforcement.

**EXCEPTIONS:** 1. Reinforcing steel not required by design.

2. When specifically approved by the building official, welding of crossing bars for assembly purposes in Seismic Zones 0, 1 and 2 may be permitted, provided that data are submitted to the building official to show that there is no detrimental effect on the action of the structural member as a result of welding of the crossing bars.

## 1907.6 Spacing Limits for Reinforcement.

**1907.6.1** The minimum clear spacing between parallel bars in a layer shall be  $d_b$  but not less than 1 inch (25 mm). See also Section 1903.3.2.

**1907.6.2** Where parallel reinforcement is placed in two or more layers, bars in the upper layers shall be placed directly above bars in the bottom layer with clear distance between layers not less than 1 inch (25 mm).

**1907.6.3** In spirally reinforced or tied reinforced compression members, clear distance between longitudinal bars shall not be less than  $1.5d_b$  or less than  $1\frac{1}{2}$  inches (38 mm). See also Section 1903.3.2.

**1907.6.4** Clear distance limitation between bars shall apply also to the clear distance between a contact lap splice and adjacent splices or bars.

**1907.6.5** In walls and slabs other than concrete joist construction, primary flexural reinforcement shall not be spaced farther apart than three times the wall or slab thickness, or 18 inches (457 mm).

### 1907.6.6 Bundled bars.

**1907.6.6.1** Groups of parallel reinforcing bars bundled in contact to act as a unit shall be limited to four bars in one bundle.

**1907.6.6.2** Bundled bars shall be enclosed within stirrups or ties.

**1907.6.6.3** Bars larger than No. 11 shall not be bundled in beams.

**1907.6.6.4** Individual bars within a bundle terminated within the span of flexural members shall terminate at different points with at least  $40d_b$  stagger.

**1907.6.6.5** Where spacing limitations and minimum concrete cover are based on bar diameter  $d_b$ , a unit of bundled bars shall be treated as a single bar of a diameter derived from the equivalent total area.

**1907.6.7 Prestressing tendons and ducts.**

**1907.6.7.1** Clear distance between pretensioning tendons at each end of a member shall not be less than  $4d_b$  for wire, or  $3d_b$  for strands. See also Section 1903.3.2. Closer vertical spacing and bundling of strands may be permitted in the middle portion of a span.

**1907.6.7.2** Posttensioning ducts may be bundled if it is shown that concrete can be satisfactorily placed and if provision is made to prevent the tendons, when tensioned, from breaking through the duct.

**1907.7 Concrete Protection for Reinforcement.**

**1907.7.1 Cast-in-place concrete (nonprestressed).** The following minimum concrete cover shall be provided for reinforcement:

	MINIMUM COVER, Inches (mm)
1. Concrete cast against and permanently exposed to earth . . . . .	3 (76)
2. Concrete exposed to earth or weather:	
No. 6 through No. 18 bar . . . . .	2 (51)
No. 5 bar, W31 or D31 wire, and smaller . . . . .	1 1/2 (38)
3. Concrete not exposed to weather or in contact with ground:	
Slabs, walls, joists:	
No. 14 and No. 18 bar . . . . .	1 1/2 (38)
No. 11 bar and smaller . . . . .	3/4 (19)
Beams, columns:	
Primary reinforcement, ties, stirrups, spirals . . . . .	1 1/2 (38)
Shells, folded plate members:	
No. 6 bar and larger . . . . .	3/4 (19)
No. 5 bar, W31 or D31 wire, and smaller . . . . .	1/2 (13)

**1907.7.2 Precast concrete (manufactured under plant control conditions).** The following minimum concrete cover shall be provided for reinforcement:

	MINIMUM COVER, Inches (mm)
1. Concrete exposed to earth or weather:	
Wall panels:	
No. 14 and No. 18 bar . . . . .	1 1/2 (38)
No. 11 bar and smaller . . . . .	3/4 (19)
Other members:	
No. 14 and No. 18 bar . . . . .	2 (51)
No. 6 through No. 11 bar . . . . .	1 1/2 (38)
No. 5 bar W31 or D31 wire, and smaller . . . . .	1 1/4 (32)
2. Concrete not exposed to weather or in contact with ground:	
Slabs, walls, joists:	
No. 14 and No. 18 bar . . . . .	1 1/4 (32)
No. 11 bar and smaller . . . . .	5/8 (16)
Beams, columns:	
Primary reinforcement . . . . .	$d_b$ but not less than 5/8 (16) and need not exceed 1 1/2 (38)
Ties, stirrups, spirals . . . . .	3/8 (9.5)
Shells, folded plate members:	
No. 6 bar and larger . . . . .	5/8 (16)
No. 5 bar, W31 or D31 wire, and smaller . . . . .	3/8 (9.5)

**1907.7.3 Prestressed concrete.**

**1907.7.3.1** The following minimum concrete cover shall be provided for prestressed and nonprestressed reinforcement, ducts and end fittings, except as provided in Sections 1907.7.3.2 and 1907.7.3.3.

	<b>MINIMUM COVER, inches (mm)</b>
1. Concrete cast against and permanently exposed to earth . . . . .	3 (76)
2. Concrete exposed to earth or weather:	
Wall panels, slabs, joists . . . . .	1 (25)
Other members . . . . .	1½ (32)
3. Concrete not exposed to weather or in contact with ground:	
Slabs, walls, joists . . . . .	¾ (19)
Beams, columns:	
Primary reinforcement . . . . .	1½ (38)
Ties, stirrups, spirals . . . . .	1 (25)
Shells, folded plate members:	
No. 5 bars, W31 or D31 wire, and smaller . . . . .	¾ (9.5)
Other reinforcement . . . . .	$d_b$ but not less than ¾ (19)

**1907.7.3.2** For prestressed concrete members exposed to earth, weather or corrosive environments, and in which permissible tensile stress of Section 1918.4.2, Item 2, is exceeded, minimum cover shall be increased 50 percent.

**1907.7.3.3** For prestressed concrete members manufactured under plant control conditions, minimum concrete cover for nonprestressed reinforcement shall be as required in Section 1907.7.2.

**1907.7.4 Bundled bars.** For bundled bars, minimum concrete cover shall be equal to the equivalent diameter of the bundle, but need not be greater than 2 inches (51 mm); except for concrete cast against and permanently exposed to earth, minimum cover shall be 3 inches (76 mm).

**1907.7.5 Corrosive environments.** In corrosive environments or other severe exposure conditions, amount of concrete protection shall be suitably increased, and denseness and nonporosity of protecting concrete shall be considered, or other protection shall be provided.

**1907.7.6 Future extensions.** Exposed reinforcement, inserts and plates intended for bonding with future extensions shall be protected from corrosion.

**1907.7.7 Fire protection.** When a thickness of cover for fire protection greater than the minimum concrete cover specified in Section 1907.7 is required, such greater thickness shall be used.

**1907.8 Special Reinforcement Details for Columns.**

**1907.8.1 Offset bars.** Offset bent longitudinal bars shall conform to the following:

**1907.8.1.1** Slope of inclined portion of an offset bar with axis of column shall not exceed 1 in 6.

**1907.8.1.2** Portions of bar above and below an offset shall be parallel to axis of column.

**1907.8.1.3** Horizontal support at offset bends shall be provided by lateral ties, spirals or parts of the floor construction. Horizontal support provided shall be designed to resist one and one-half times the horizontal component of the computed force in the inclined portion of an offset bar. Lateral ties or spirals, if used, shall be placed not more than 6 inches (152 mm) from points of bend.

**1907.8.1.4** Offset bars shall be bent before placement in the forms. See Section 1907.3.

**1907.8.1.5** Where a column face is offset 3 inches (76 mm) or greater, longitudinal bars shall not be offset bent. Separate dowels, lap spliced with the longitudinal bars adjacent to the offset column faces, shall be provided. Lap splices shall conform to Section 1912.17.

**1907.8.2 Steel cores.** Load transfer in structural steel cores of composite compression members shall be provided by the following:

**1907.8.2.1** Ends of structural steel cores shall be accurately finished to bear at end-bearing splices, with positive provision for alignment of one core above the other in concentric contact.

**1907.8.2.2** At end-bearing splices, bearing shall be considered effective to transfer not more than 50 percent of the total compressive stress in the steel core.

**1907.8.2.3** Transfer of stress between column base and footing shall be designed in accordance with Section 1915.8.

**1907.8.2.4** Base of structural steel section shall be designed to transfer the total load from the entire composite member to the footing; or, the base may be designed to transfer the load from the steel core only, provided ample concrete section is available for transfer of the portion of the total load carried by the reinforced concrete section to the footing by compression in the concrete and by reinforcement.

### **1907.9 Connections.**

**1907.9.1** At connections of principal framing elements (such as beams and columns), enclosure shall be provided for splices of continuing reinforcement and for end anchorage of reinforcement terminating in such connections.

**1907.9.2** Enclosure at connections may consist of external concrete or internal closed ties, spirals or stirrups.

### **1907.10 Lateral Reinforcement for Compression Members.**

**1907.10.1** Lateral reinforcement for compression members shall conform to the provisions of Sections 1907.10.4 and 1907.10.5 and, where shear or torsion reinforcement is required, shall also conform to provisions of Section 1911.

**1907.10.2** Lateral reinforcement requirements for composite compression members shall conform to Section 1910.14. Lateral reinforcement requirements for prestressing tendons shall conform to Section 1918.11.

**1907.10.3** Lateral reinforcement requirements of Sections 1907.10, 1910.14 and 1918.11 may be waived where tests and structural analyses show adequate strength and feasibility of construction.

**1907.10.4 Spirals.** Spiral reinforcement for compression members shall conform to Section 1910.9.3 and to the following:

**1907.10.4.1** Spirals shall consist of evenly spaced continuous bar or wire of such size and so assembled as to permit handling and placing without distortion from designed dimensions.

**1907.10.4.2** For cast-in-place construction, size of spirals shall not be less than  $\frac{3}{8}$ -inch (9.5 mm) diameter.

**1907.10.4.3** Clear spacing between spirals shall not exceed 3 inches (76 mm) or be less than 1 inch (25 mm). See also Section 1903.3.2.

**1907.10.4.4** Anchorage of spiral reinforcement shall be provided by one and one-half extra turns of spiral bar or wire at each end of a spiral unit.

**1907.10.4.5** Splices in spiral reinforcement shall be lap splices of  $48d_b$ , but not less than 12 inches (305 mm) or welded.

**1907.10.4.6** Spirals shall extend from top of footing or slab in any story to level of lowest horizontal reinforcement in members supported above.

**1907.10.4.7** Where beams or brackets do not frame into all sides of a column, ties shall extend above termination of spiral to bottom of slab or drop panel.

**1907.10.4.8** In columns with capitals, spirals shall extend to a level at which the diameter or width of capital is two times that of the column.

**1907.10.4.9** Spirals shall be held firmly in place and true to line.

**1907.10.5 Ties.** Tie reinforcement for compression members shall conform to the following:

**1907.10.5.1** All nonprestressed bars shall be enclosed by lateral ties, at least No. 3 in size for longitudinal bars No. 10 or smaller, and at least No. 4 in size for Nos. 11, 14 and 18 and bundled longitudinal bars. Deformed wire or welded wire fabric of equivalent area may be used.

**1907.10.5.2** Vertical spacing of ties shall not exceed 16 longitudinal bar diameters, 48 tie bar or wire diameters, or least dimension of the compression member.

**1907.10.5.3** Ties shall be arranged such that every corner and alternate longitudinal bar shall have lateral support provided by the corner of a tie with an included angle of not more than 135 degrees and a bar shall be not farther than 6 inches (152 mm) clear on each side along the tie from such a laterally supported bar. Where longitudinal bars are located around the perimeter of a circle, a complete circular tie may be used.

**1907.10.5.4** Ties shall be located vertically not more than one half a tie spacing above the top of footing or slab in any story and shall be placed as provided herein to not more than one half a tie spacing below the lowest horizontal reinforcement *in members supported above*.

**1907.10.5.5** Where beams or brackets frame from four directions into a column, ties may be terminated not more than 3 inches (76 mm) below lowest reinforcement in shallowest of such beams or brackets.

**1907.10.5.6** *Column lateral ties shall be as specified in Section 1907.1.3, Item 3.*

**1907.11 Lateral Reinforcement for Flexural Members.**

**1907.11.1** Compression reinforcement in beams shall be enclosed by ties or stirrups satisfying the size and spacing limitations in Section 1907.10.5 or by welded wire fabric of equivalent area. Such ties or stirrups shall be provided throughout the distance where compression reinforcement is required.

**1907.11.2** Lateral reinforcement for flexural framing members subject to stress reversals or to torsion at supports shall consist of closed ties, closed stirrups, or spirals extending around the flexural reinforcement.

**1907.11.3** Closed ties or stirrups may be formed in one piece by overlapping standard stirrup or tie end hooks around a longitudinal bar, or formed in one or two pieces lap spliced with a Class B splice (lap of  $1.3 l_d$ ), or anchored in accordance with Section 1912.13.

**1907.12 Shrinkage and Temperature Reinforcement.**

**1907.12.1** Reinforcement for shrinkage and temperature stresses normal to flexural reinforcement shall be provided in structural slabs where the flexural reinforcement extends in one direction only.

**1907.12.1.1** Shrinkage and temperature reinforcement shall be provided in accordance with either Section 1907.12.2 or 1907.12.3 below.

**1907.12.2** Deformed reinforcement conforming to Section 1903.5.3 used for shrinkage and temperature reinforcement shall be provided in accordance with the following:

**1907.12.2.1** Area of shrinkage and temperature reinforcement shall provide at least the following ratios of reinforcement area to gross concrete area, but not less than 0.0014:

- |  |                                    |
|--|------------------------------------|
| 1. Slabs where Grade 40 or 50 deformed bars are used   | 0.0020                             |
| 2. Slabs where Grade 60 deformed bars or welded wire fabric (smooth or deformed) are used  | 0.0018                             |
| 3. Slabs where reinforcement with yield stress exceeding 60,000 psi (413.7 MPa) measured at a yield strain of 0.35 percent is used | $\frac{0.0018 \times 60,000}{f_y}$ |

For SI:  $\frac{0.0018 \times 413.7}{f_y}$

**1907.12.2.2** Shrinkage and temperature reinforcement shall be spaced not farther apart than five times the slab thickness, or 18 inches (457 mm).

**1907.12.2.3** At all sections where required, reinforcement for shrinkage and temperature stresses shall develop the specified yield strength  $f_y$  in tension in accordance with Section 1912.

**1907.12.3** Prestressing tendons conforming to Section 1903.5.5 used for shrinkage and temperature reinforcement shall be provided in accordance with the following:

**1907.12.3.1** Tendons shall be proportioned to provide a minimum average compressive stress of 100 psi (0.69 MPa) on gross concrete area using effective prestress, after losses, in accordance with Section 1918.6.

**1907.12.3.2** Spacing of prestressed tendons used for shrinkage and temperature reinforcement shall not exceed 6 feet (1829 mm).

**1907.12.3.3** When the spacing of prestressed tendons used for shrinkage and temperature reinforcement exceeds 54 inches (1372 mm), additional bonded shrinkage and temperature reinforcement conforming with Section 1907.12.2 shall be provided between the tendons at slab edges extending from the slab edge for a distance equal to the tendon spacing.

## SECTION 1908 — ANALYSIS AND DESIGN

### 1908.0 Notations.

$A_s$  = area of nonprestressed tension reinforcement, square inches (mm<sup>2</sup>).

$A'_s$  = area of compression reinforcement, square inches (mm<sup>2</sup>).

$b$  = width of compression face of member, inches (mm).

$d$  = distance from extreme compression fiber to centroid of tension reinforcement, inches (mm).

$E_c$  = modulus of elasticity of concrete, pounds per square inch (MPa). See Section 1908.1.

$E_s$  = modulus of elasticity of reinforcement, pounds per square inch (MPa). See Sections 1908.2 and 1908.5.3.

$f'_c$  = specified compressive strength of concrete, pounds per square inch (MPa).

$f_y$  = specified yield strength of nonprestressed reinforcement, pounds per square inch (MPa).

$l_n$  = clear span for positive moment or shear and average of adjacent clear spans for negative moment.

$V_c$  = nominal shear strength provided by concrete.

$w_c$  = unit weight of concrete, pounds per cubic foot (kg/m<sup>3</sup>).

$w_u$  = factored load per unit length of beam or per unit area of slab.

$\beta_1$  = factor defined in Section 1910.2.7.3.

$\rho$  = ratio of nonprestressed tension reinforcement.

- =  $A_s/bd$ .
- $\rho'$  = ratio of nonprestressed compression reinforcement.
- =  $A'_s/bd$ .
- $\rho_b$  = reinforcement ratio producing balanced strain conditions. See Section 1910.3, Item 1.
- $\phi$  = strength-reduction factor. See Section 1909.3.

**1908.1 Design Methods.**

**1908.1.1** In design of reinforced concrete structures, members shall be proportioned for adequate strength in accordance with provisions of this code, using load factors and strength-reduction factors  $\phi$  specified in Section 1909.

**1908.1.2** Nonprestressed reinforced concrete members may be designed using the provisions of Section 1926.

**1908.2 Loading.**

**1908.2.1** Design provisions of this code are based on the assumption that structures shall be designed to resist all applicable loads.

**1908.2.2** Service loads shall be in accordance with Chapter 16 with appropriate live load reductions as permitted therein.

**1908.2.3** In design for wind and earthquake loads, integral structural parts shall be designed to resist the total lateral loads.

**1908.2.4** Consideration shall be given to effects of forces due to prestressing, crane loads, vibration, impact, shrinkage, temperature changes, creep and unequal settlement of supports.

**1908.3 Methods of Analysis.**

**1908.3.1** All members of frames or continuous construction shall be designed for the maximum effects of factored loads as determined by the theory of elastic analysis, except as modified by Section 1908.4. It is permitted to simplify the design by using the assumptions specified in Sections 1908.6 through 1908.9.

**1908.3.2** Except for prestressed concrete, approximate methods of frame analysis may be used for buildings of usual types of construction, spans and story heights.

**1908.3.3** In lieu of frame analysis, the following approximate moments and shears may be used in design of continuous beams and one-way slabs (slabs reinforced to resist flexural stresses in only one direction), provided:

1. There are two or more spans,
2. Spans are approximately equal, with the larger of two adjacent spans not greater than the shorter by more than 20 percent,
3. Loads are uniformly distributed, and
4. Unit live load does not exceed three times unit dead load, and
5. Members are prismatic.

Positive moment:

End spans

Discontinuous end unrestrained . . . . .  $w_u l_n^2/11$

Discontinuous end integral with support . . . . .  $w_u l_n^2/14$

Interior spans . . . . .  $w_u l_n^2/16$

Negative moment at exterior face of first interior support	
Two spans . . . . .	$w_u l_n^2/9$
More than two spans . . . . .	$w_u l_n^2/10$
Negative moment at other faces of interior supports . . . . .	$w_u l_n^2/11$
Negative moment at face of all supports for:	
Slabs with spans not exceeding 10 feet (3048 mm), and beams where ratio of sum of column stiffnesses to beam stiffness exceeds eight at each end of the span . . . . .	$w_u l_n^2/12$
Negative moment at interior face of exterior support for members built integrally with supports:	
Where support is a spandrel beam . . . . .	$w_u l_n^2/24$
Where support is a column . . . . .	$w_u l_n^2/16$
Shear in end members at face of first interior support . . . . .	$1.15 w_u l_n/2$
Shear at face of all other supports . . . . .	$w_u l_n/2$

#### 1908.4 Redistribution of Negative Moments in Continuous Nonprestressed Flexural Members.

**1908.4.1** Except where approximate values for moments are used, it is permitted to increase or decrease negative moments calculated by elastic theory at supports of continuous flexural members for any assumed loading arrangement by not more than

$$20 \left( 1 - \frac{\rho - \rho'}{\rho_b} \right) \text{ percent}$$

**1908.4.2** The modified negative moments shall be used for calculating moments at sections within the spans.

**1908.4.3** Redistribution of negative moments shall be made only when the section, at which moment is reduced, is so designed that  $\rho$  or  $\rho - \rho'$  is not greater than  $0.50 \rho_b$ , where

$$\rho_b = \frac{0.85 \beta_1 f'_c}{f_y} \frac{87,000}{87,000 + f_y} \quad (8-1)$$

For SI:

$$\rho_b = \frac{0.85 \beta_1 f'_c}{f_y} \frac{600}{600 + f_y}$$

**1908.4.4** For criteria on moment redistribution for prestressed concrete members, see Section 1918.

#### 1908.5 Modulus of Elasticity.

**1908.5.1** Modulus of elasticity  $E_c$  for concrete may be taken as  $w_c^{1.5} 33 \sqrt{f'_c}$  (in psi) [For SI:  $w_c^{1.5} 0.043 \sqrt{f'_c}$  (in MPa)] for values of  $w_c$  between 90 pcf and 155 pcf (1440 kg/m<sup>3</sup> and 2420 kg/m<sup>3</sup>). For normal-weight concrete,  $E_c$  may be taken as  $57,000 \sqrt{f'_c}$  (For SI:  $4730 \sqrt{f'_c}$ ).

**1908.5.2** Modulus of elasticity  $E_s$  for nonprestressed reinforcement may be taken as 29,000,000 psi (200 000 MPa).

**1908.5.3** Modulus of elasticity  $E_s$  for prestressing tendons shall be determined by tests or supplied by the manufacturer.

**1908.6 Stiffness.**

**1908.6.1** Use of any set of reasonable assumptions is permitted for computing relative flexural and torsional stiffnesses of columns, walls, floors and roof systems. The assumptions adopted shall be consistent throughout analysis.

**1908.6.2** Effect of haunches shall be considered both in determining moments and in design of members.

**1908.7 Span Length.**

**1908.7.1** Span length of members not built integrally with supports shall be considered the clear span plus depth of member, but need not exceed distance between centers of supports.

**1908.7.2** In analysis of frames or continuous construction for determination of moments, span length shall be taken as the distance center to center of supports.

**1908.7.3** For beams built integrally with supports, design on the basis of moments at faces of support is permitted.

**1908.7.4** Solid or ribbed slabs built integrally with supports, with clear spans not more than 10 feet (3048 mm), may be analyzed as continuous slabs on knife edge supports with spans equal to the clear spans of the slab and width of beams otherwise neglected.

**1908.8 Columns.**

**1908.8.1** Columns shall be designed to resist the axial forces from factored loads on all floors or roof and the maximum moment from factored loads on a single adjacent span of the floor or roof under consideration. Loading condition giving the maximum ratio of moment to axial load shall also be considered.

**1908.8.2** In frames or continuous construction, consideration shall be given to the effect of unbalanced floor or roof loads on both exterior and interior columns and of eccentric loading due to other causes.

**1908.8.3** In computing gravity load moments in columns, it is permitted to assume as fixed, far ends of columns built integrally with the structure.

**1908.8.4** Resistance to moments at any floor or roof level shall be provided by distributing the moment between columns immediately above and below the given floor in proportion to the relative column stiffnesses and conditions of restraint.

**1908.9 Arrangement of Live Load.**

**1908.9.1** It is permissible to assume that (1) the live load is applied only to the floor or roof under consideration, and (2) the far ends of columns built integrally with the structure are considered to be fixed.

**1908.9.2** It is permitted to assume that the arrangement of live load is limited to combinations of:

1. Factored dead load on all spans with full-factored live load on two adjacent spans, and
2. Factored dead load on all spans with full-factored live load on alternate spans.

**1908.10 T-beam Construction.**

**1908.10.1** In T-beam construction, the flange and web shall be built integrally or otherwise effectively bonded together.

**1908.10.2** Width of slab effective as a T-beam flange shall not exceed one fourth the span length of the beam, and the effective overhanging slab width on each side of the web shall not exceed:

1. Eight times the slab thickness, or

2. One half the clear distance to the next web.

**1908.10.3** For beams with a slab on one side only, the effective overhanging flange width shall not exceed:

1. One twelfth the span length of the beam,
2. Six times the slab thickness, or
3. One half the clear distance to the next web.

**1908.10.4** Isolated beams, in which the T-shape is used to provide a flange for additional compression area, shall have a flange thickness not less than one half the width of web and an effective flange width not more than four times the width of web.

**1908.10.5** Where primary flexural reinforcement in a slab that is considered as a T-beam flange (excluding joist construction) is parallel to the beam, reinforcement perpendicular to the beam shall be provided in the top of the slab in accordance with the following:

**1908.10.5.1** Transverse reinforcement shall be designed to carry the factored load on the overhanging slab width assumed to act as a cantilever. For isolated beams, the full width of overhanging flange shall be considered. For other T-beams, only the effective overhanging slab width need be considered.

**1908.10.5.2** Transverse reinforcement shall be spaced not farther apart than five times the slab thickness or 18 inches (457 mm).

#### **1908.11 Joist Construction.**

**1908.11.1** Joist construction consists of a monolithic combination of regularly spaced ribs and a top slab arranged to span in one direction or two orthogonal directions.

**1908.11.2** Ribs shall not be less than 4 inches (102 mm) in width and shall have a depth of not more than three and one-half times the minimum width of rib.

**1908.11.3** Clear spacing between ribs shall not exceed 30 inches (762 mm).

**1908.11.4** Joist construction not meeting the limitations of the preceding two paragraphs shall be designed as slabs and beams.

**1908.11.5** When permanent burned clay or concrete tile fillers of material having a unit compressive strength at least equal to that of the specified strength of concrete in the joists are used:

**1908.11.5.1** For shear and negative-moment strength computations, it is permitted to include the vertical shells of fillers in contact with ribs. Other portions of fillers shall not be included in strength computations.

**1908.11.5.2** Slab thickness over permanent fillers shall not be less than one twelfth the clear distance between ribs nor less than one and one-half inches (38 mm).

**1908.11.5.3** In one-way joists, reinforcement normal to the ribs shall be provided in the slab as required by Section 1907.12.

**1908.11.6** When removable forms or fillers not complying with Section 1908.11.5 are used:

**1908.11.6.1** Slab thickness shall not be less than one twelfth the clear distance between ribs, or less than 2 inches (51 mm).

**1908.11.6.2** Reinforcement normal to the ribs shall be provided in the slab as required for flexure, considering load concentrations, if any, but not less than required by Section 1907.12.

**1908.11.7** Where conduits or pipes as permitted by Section 1906.3 are embedded within the slab, slab thickness shall be at least 1 inch (25 mm) greater than the total overall depth of the conduits or pipes at any point. Conduits or pipes shall not impair significantly the strength of the construction.

**1908.11.8** For joist construction, contribution of concrete to shear strength  $V_c$  is permitted to be 10 percent more than that specified in Section 1911. It is permitted to increase shear strength using shear reinforcement or by widening the ends of the ribs.

**1908.12 Separate Floor Finish.**

**1908.12.1** A floor finish shall not be included as part of a structural member unless placed monolithically with the floor slab or designed in accordance with requirements of Section 1917.

**1908.12.2** All concrete floor finishes may be considered as part of required cover or total thickness for nonstructural considerations.

**SECTION 1909 — STRENGTH AND SERVICEABILITY REQUIREMENTS**

**1909.0 Notations.**

- ▶  $A_g$  = gross area of section, square inches ( $\text{mm}^2$ ).
- ▶  $A'_s$  = area of compression reinforcement, square inches ( $\text{mm}^2$ ).
- ▶  $b$  = width of compression face of member, inches (mm).
- ▶  $D$  = dead loads, or related internal moments and forces.
- ▶  $d$  = distance from extreme compression fiber to centroid of tension reinforcement, inches (mm).
- ▶  $d'$  = distance from extreme compression fiber to centroid of compression reinforcement, inches (mm).
- ▶  $d_s$  = distance from extreme tension fiber to centroid of tension reinforcement, inches (mm).
- ▶  $E$  = load effects of earthquake, or related internal moments and forces.
- ▶  $E_c$  = modulus of elasticity of concrete, pounds per square inch (MPa). See Section 1908.1.
- ▶  $F$  = loads due to weight and pressures of fluids with well-defined densities and controllable maximum heights, or related internal moments and forces.
- ▶  $f'_c$  = specified compressive strength of concrete, pounds per square inch (MPa).
- ▶  $\sqrt{f'_c}$  = square root of specified compressive strength of concrete, pounds per square inch (MPa).
- ▶  $f_{ct}$  = average splitting tensile strength of lightweight aggregate concrete, pounds per square inch (MPa).
- ▶  $f_r$  = modulus of rupture of concrete, pounds per square inch (MPa).
- ▶  $f_y$  = specified yield strength of nonprestressed reinforcement, pounds per square inch (MPa).
- ▶  $H$  = loads due to weight and pressure of soil, water in soil, or other materials, or related internal moments and forces.
- ▶  $h$  = overall thickness of member, inches (mm).
- ▶  $I_{cr}$  = moment of inertia of cracked section transformed to concrete.
- ▶  $I_e$  = effective moment of inertia for computation of deflection.
- ▶  $I_g$  = moment of inertia of gross concrete section about centroidal axis, neglecting reinforcement.
- ▶  $L$  = live loads, or related internal moments and forces.
- ▶  $l$  = span length of beam or one-way slab, as defined in Section 1908.7; clear projection of cantilever, inches (mm).
- ▶  $l_n$  = length of clear span in long direction of two-way construction, measured face to face of supports in slabs without beams and face to face of beams or other supports in other cases.
- ▶  $M_u$  = maximum moment in member at stage deflection is computed.
- ▶  $M_{cr}$  = cracking moment. See Formula (9-8).

- $P_b$  = nominal axial load strength at balanced strain conditions. See Section 1910.3.2.  
 $P_n$  = nominal axial load strength at given eccentricity.  
 $T$  = cumulative effects of temperature, creep, shrinkage and differential settlement.  
 $U$  = required strength to resist factored loads or related internal moments and forces.  
 $W$  = wind load, or related internal moments and forces.  
 $w_c$  = weight of concrete, pounds per cubic foot ( $\text{kg}/\text{m}^3$ ).  
 $y_t$  = distance from centroidal axis of gross section, neglecting reinforcement, to extreme fiber in tension.  
 $\alpha$  = ratio of flexural stiffness of beam section to flexural stiffness of a width of slab bounded laterally by center line of adjacent panel (if any) on each side of beam. See Section 1913.  
 $\alpha_m$  = average value of  $\alpha$  for all beams on edges of a panel.  
 $\beta$  = ratio of clear spans in long-to-short direction of two-way slabs.  
 $\xi$  = time-dependent factor for sustained load. See Section 1909.5.2.5.  
 $\lambda$  = multiplier for additional long-time deflection as defined in Section 1909.5.2.5.  
 $\rho'$  = reinforcement ratio for nonprestressed compression reinforcement.  $A'_g/bd$ .  
 $\phi$  = strength-reduction factor. See Section 1909.3.

### 1909.1 General.

**1909.1.1** Structures and structural members shall be designed to have design strengths at all sections at least equal to the required strengths calculated for the factored loads and forces in such combinations as are stipulated in this code.

**1909.1.2** Members also shall meet all other requirements of this code to ensure adequate performance at service load levels.

### 1909.2 Required Strength.

**1909.2.1** Required strength  $U$  to resist dead load  $D$  and live load  $L$  shall be at least equal to

$$U = 1.4D + 1.7L \quad (9-1)$$

**1909.2.2** If resistance to structural effects of a specified wind load  $W$  are included in design, the following combinations of  $D$ ,  $L$  and  $W$  shall be investigated to determine the greatest required strength  $U$

$$U = 0.75(1.4D + 1.7L + 1.7W) \quad (9-2)$$

where load combinations shall include both full value and zero value of  $L$  to determine the more severe condition, and

$$U = 0.9D + 1.3W \quad (9-3)$$

but for any combination of  $D$ ,  $L$  and  $W$ , required strength  $U$  shall not be less than Formula (9-1).

**1909.2.3** If resistance to specified earthquake loads or forces  $E$  are included in design, load combinations of Section 1909.2.2 shall apply, except that  $1.1E$  shall be substituted for  $W$ . *Load factors contained in Sections 1921 and 1926 shall be used where applicable.*

**1909.2.4** If resistance to earth pressure  $H$  is included in design, required strength  $U$  shall be at least equal to

$$U = 1.4D + 1.7L + 1.7H \quad (9-4)$$

except that where  $D$  or  $L$  reduces the effect of  $H$ ,  $0.9D$  shall be substituted for  $1.4D$  and zero value of  $L$  shall be used to determine the greatest required strength  $U$ . For any combination of  $D$ ,  $L$  and  $H$ , required strength  $U$  shall not be less than Formula (9-1).

**1909.2.5** If resistance to loadings due to weight and pressure of fluids with well-defined densities and controllable maximum heights  $F$  is included in design, such loading shall have a load factor of 1.4 and be added to all loading combinations that include live load.

**1909.2.6** If resistance to impact effects is taken into account in design, such effects shall be included with live load  $L$ .

**1909.2.7** Where structural effects  $T$  of differential settlement, creep, shrinkage or temperature change may be significant in design, required strength  $U$  shall be at least equal to

$$U = 0.75 (1.4D + 1.4T + 1.7L) \tag{9-5}$$

but required strength  $U$  shall not be less than

$$U = 1.4 (D + T) \tag{9-6}$$

Estimations of differential settlement, creep, shrinkage or temperature change shall be based on a realistic assessment of such effects occurring in service.

**1909.3 Design Strength.**

**1909.3.1** Design strength provided by a member, its connection to other members and its cross sections, in terms of flexure, axial load, shear and tension, shall be taken as the nominal strength calculated in accordance with requirements and assumptions of this code, multiplied by a strength-reduction factor  $\phi$ .

**1909.3.2** Strength-reduction factor  $\phi$  shall be as follows:

- 1909.3.2.1** Flexure, without axial load . . . . . 0.90
- 1909.3.2.2** Axial load and axial load with flexure. (For axial load with flexure, both axial load and moment nominal strength shall be multiplied by appropriate single value of  $\phi$ .)
- Axial tension and axial tension with flexure . . . . . 0.90
- Axial compression and axial compression with flexure:
- Members with spiral reinforcement conforming to Section 1910.9.3 . . . . . 0.75
- Other reinforced members . . . . . 0.70

except that for low values of axial compression,  $\phi$  may be increased in accordance with the following:

For members in which  $f_y$  does not exceed 60,000 psi (413.7 MPa), with symmetric reinforcement, and with  $(h - d' - d_s)/h$  not less than 0.70,  $\phi$  may be increased linearly to 0.90 as  $\phi P_n$  decreases from  $0.10 f'_c A_g$  to zero.

For other reinforced members,  $\phi$  may be increased linearly to 0.90 as  $\phi P_n$  decreases from  $0.10 f'_c A_g$  or  $\phi P_b$ , whichever is smaller, to zero.

**1909.3.2.3** Shear and torsion (See also Section 1909.3.4 for shear walls and frames in Seismic Zones 3 and 4) . . . . . 0.85

**1909.3.2.4** Bearing on concrete (See also Section 1918.13) . . . . . 0.70

**1909.3.3** Development lengths specified in Section 1912 do not require a  $\phi$  factor.

**1909.3.4** In *Seismic Zones 3 and 4*, strength-reduction factors shall be as given above except for the following:

**1909.3.4.1** *The shear strength-reduction factor shall be 0.6 for the design of walls, topping slabs used as diaphragms over precast concrete members and structural framing members, with the*

exception of joints, if their nominal shear strength is less than the shear corresponding to development of their nominal flexural strength. The shear strength-reduction factor for joints shall be 0.85.

**1909.3.4.2** The strength-reduction factor for axial compression and flexure shall be 0.5 for all frame members with factored axial compressive forces exceeding  $(A_g f'_c/10)$  if the transverse reinforcement does not conform to Section 1921.4.4.

**1909.4 Design Strength for Reinforcement.** Designs shall not be based on a yield strength of reinforcement  $f_y$  in excess of 80,000 psi (551.6 MPa), except for prestressing tendons.

**1909.5 Control of Deflections.**

**1909.5.1** Reinforced concrete members subject to flexure shall be designed to have adequate stiffness to limit deflections or any deformations that affect strength or serviceability of a structure adversely.

**1909.5.2 One-way construction (nonprestressed).**

**1909.5.2.1** Minimum thickness stipulated in Table 19-C-1 shall apply for one-way construction not supporting or attached to partitions or other construction likely to be damaged by large deflections, unless computation of deflection indicates a lesser thickness may be used without adverse effects.

**1909.5.2.2** Where deflections are to be computed, deflections that occur immediately on application of load shall be computed by usual methods or formulas for elastic deflections, considering effects of cracking and reinforcement on member stiffness.

**1909.5.2.3** Unless stiffness values are obtained by a more comprehensive analysis, immediate deflection shall be computed with the modulus of elasticity  $E_c$  for concrete as specified in Section 1908.5.1 (normal-weight or lightweight concrete) and with the effective moment of inertia as follows, but not greater than  $I_g$ .

$$I_e = \left( \frac{M_{cr}}{M_a} \right)^3 I_g + \left[ 1 - \left( \frac{M_{cr}}{M_a} \right)^3 \right] I_{cr} \quad (9-7)$$

**WHERE:**

$$M_{cr} = \frac{f_r I_g}{y_t} \quad (9-8)$$

and for normal-weight concrete

$$f_r = 7.5 \sqrt{f'_c} \quad (9-9)$$

For **SI:**  $f_r = 0.62 \sqrt{f'_c}$

When lightweight aggregate concrete is used, one of the following modifications shall apply:

1. When  $f_{ct}$  is specified and concrete is proportioned in accordance with Section 1905.2,  $f_r$  shall be modified by substituting  $f_{ct}/6.7$  (For **SI:**  $1.8f_{ct}$ ) for  $\sqrt{f'_c}$ , but the value of  $f_{ct}/6.7$  (For **SI:**  $1.8f_{ct}$ ) shall not exceed  $\sqrt{f'_c}$ .
2. When  $f_{ct}$  is not specified,  $f_r$  shall be multiplied by 0.75 for “all-lightweight” concrete, and 0.85 for “sand-lightweight” concrete. Linear interpolation may be used when partial sand replacement is used.

**1909.5.2.4** For continuous members, effective moment of inertia may be taken as the average of values obtained from Formula (9-7) for the critical positive and negative moment sections. For prismatic members, effective moment of inertia may be taken as the value obtained from Formula (9-7) at midspan for simple and continuous spans, and at support for cantilevers.

**1909.5.2.5** Unless values are obtained by a more comprehensive analysis, additional longtime deflection resulting from creep and shrinkage of flexural members (normal-weight or lightweight concrete) shall be determined by multiplying the immediate deflection caused by the sustained load considered, by the factor

$$\lambda = \frac{\xi}{1 + 50\rho'} \quad (9-10)$$

where  $\rho'$  shall be the value at midspan for simple and continuous spans, and at support for cantilevers. It is permitted to assume the time-dependent factor for sustained loads to be equal to

Five years or more	2.0
12 months	1.4
Six months	1.2
Three months	1.0

**1909.5.2.6** Deflection computed in accordance with this section shall not exceed limits stipulated in Table 19-I.

**1909.5.3 Two-way construction (nonprestressed).**

**1909.5.3.1** This section shall govern the minimum thickness of slabs or other two-way construction designed in accordance with the provisions of Section 1913 and conforming with the requirements of Section 1913.6.1.2. The thickness of slabs without interior beams spanning between the supports on all sides shall satisfy the requirements of Section 1909.5.3.2 or 1909.5.3.4. Thickness of slabs with beams spanning between the supports on all sides shall satisfy the requirements of Section 1909.5.3.3 or 1909.5.3.4.

**1909.5.3.2** For slabs without interior beams spanning between the supports and having a ratio of long to short span not greater than 2, the minimum thickness shall be in accordance with the provisions of Table 19-C-2 and shall not be less than the following values:

1. Slabs without drop panels as defined in Sections 1913.4.7.1 and 1913.4.7.2 . . . . . 5 inches (127 mm)
2. Slabs with drop panels as defined in Sections 1913.4.7.1 and 1913.4.7.2 . . . . . 4 inches (102 mm)

**1909.5.3.3** For slabs with beams spanning between the supports on all sides, the minimum thickness shall be as follows:

1. For  $\alpha_m$  equal to or less than 0.2, the provisions of Section 1909.5.3.2 shall apply.
2. For  $\alpha_m$  greater than 0.2 but not greater than 2.0, the thickness shall not be less than

$$h = \frac{l_n \left( 0.8 + \frac{f_y}{200,000} \right)}{36 + 5\beta(\alpha_m - 0.2)} \quad (9-11)$$

For SI:

$$h = \frac{l_n \left( 0.8 + \frac{f_y}{1370} \right)}{36 + 5\beta(\alpha_m - 0.2)}$$

but not less than 5 inches (127 mm).

3. For  $\alpha_m$  greater than 2.0, the thickness shall not be less than

$$h = \frac{l_n \left( 0.8 + \frac{f_y}{200,000} \right)}{36 + 9\beta} \quad (9-12)$$

For SI:

$$h = \frac{l_n \left( 0.8 + \frac{f_y}{1370} \right)}{36 + 9\beta}$$

but not less than 3.5 inches (89 mm).

4. At discontinuous edges, an edge beam shall be provided with a stiffness ratio  $\alpha$  not less than 0.80; or the minimum thickness required by Formula (9-11) or (9-12) shall be increased by at least 10 percent in the panel with a discontinuous edge.

**1909.5.3.4** Slab thickness less than the minimum thickness required by Sections 1909.5.3.1, 1909.5.3.2 and 1909.5.3.3 may be used if shown by computation that the deflection will not exceed the limits stipulated in Table 19-C-1. Deflections shall be computed taking into account size and shape of the panel, conditions of support, and nature of restraints at the panel edges. The modulus of elasticity of concrete  $E_c$  shall be as specified in Section 1908.5.1. The effective moment of inertia shall be that given by Formula (9-7); other values may be used if they result in computed deflections in reasonable agreement with the results of comprehensive tests. Additional long-term deflection shall be computed in accordance with Section 1909.5.2.5.

#### 1909.5.4 Prestressed concrete construction.

**1909.5.4.1** For flexural members designed in accordance with provisions of Section 1918, immediate deflection shall be computed by usual methods or formulas for elastic deflections, and the moment of inertia of the gross concrete section may be used for uncracked sections.

**1909.5.4.2** Additional long-time deflection of prestressed concrete members shall be computed taking into account stresses in concrete and steel under sustained load and including effects of creep and shrinkage of concrete and relaxation of steel.

Deflection computed in accordance with this section shall not exceed limits stipulated in Table 19-I.

#### 1909.5.5 Composite construction.

**1909.5.5.1 Shored construction.** If composite flexural members are supported during construction so that, after removal of temporary supports, dead load is resisted by the full composite section, the composite member may be considered equivalent to a monolithically cast member for computation of deflection. For nonprestressed members, the portion of the member in compression shall determine whether values in Table 19-C-1 for normal-weight or lightweight concrete shall apply. If deflection is computed, account should be taken of curvatures resulting from differential shrinkage of precast and cast-in-place components, and of axial creep effects in a prestressed concrete member.

**1909.5.5.2 Unshored construction.** If the thickness of a nonprestressed precast flexural member meets the requirements of Table 19-C-1, deflection need not be computed. If the thickness of a nonprestressed composite member meets the requirements of Table 19-D, deflection occurring after the member becomes composite need not be computed, but the long-time deflection of the precast member should be investigated for magnitude and duration of load prior to beginning of effective composite action.

**1909.5.5.3** Deflection computed in accordance with this section shall not exceed limits stipulated in Table 19-I.

**SECTION 1910 — FLEXURE AND AXIAL LOADS****1910.0 Notations.**

- $A$  = effective tension area of concrete surrounding the flexural tension reinforcement and having the same centroid as that reinforcement, divided by the number of bars or wires, square inches ( $\text{mm}^2$ ). When the flexural reinforcement consists of different bar or wire sizes, the number of bars or wires shall be computed as the total area of reinforcement divided by the area of the largest bar or wire used.
- $A_c$  = area of core of spirally reinforced compression member measured to outside diameter of spiral, square inches ( $\text{mm}^2$ ).
- $A_g$  = gross area of section, square inches ( $\text{mm}^2$ ).
- $A_s$  = area of nonprestressed tension reinforcement, square inches ( $\text{mm}^2$ ).
- $A_{sk}$  = area of skin reinforcement per unit height in one side face, square inches per foot ( $\text{mm}^2/\text{m}$ ).
- $A_{st}$  = total area of longitudinal reinforcement (bars or steel shapes), square inches ( $\text{mm}^2$ ).
- $A_t$  = area of structural steel shape, pipe or tubing in a composite section, square inches ( $\text{mm}^2$ ).
- $A_1$  = loaded area.
- $A_2$  = the area of the lower base of the largest frustum of a pyramid, cone, or tapered wedge contained wholly within the support and having for its upper base the loaded area, and having side slopes of 1 unit vertical in 2 units horizontal (50% slope).
- $a$  = depth of equivalent rectangular stress block as defined in Section 1910.2.7.1.
- $b$  = width of compression face of member, inches (mm).
- $C_m$  = a factor relating actual moment diagram to an equivalent uniform moment diagram.
- $c$  = distance from extreme compression fiber to neutral axis, inches (mm).
- $d$  = distance from extreme compression fiber to centroid of tension reinforcement, inches (mm).
- $d_c$  = thickness of concrete cover measured from extreme tension fiber to center of bar or wire located closest thereto, inches (mm).
- $E_c$  = modulus of elasticity of concrete, pounds per square inch (MPa). See Section 1908.5.1.
- $E_s$  = modulus of elasticity of reinforcement, pounds per square inch (MPa). See Sections 1908.5.2 and 1908.5.3.
- $El$  = flexural stiffness of compression member. See Formula (10-9).
- $f'_c$  = specified compressive strength of concrete, pounds per square inch (MPa).
- $f_s$  = calculated stress in reinforcement at service loads, kips per square inch (MPa).
- $f_y$  = specified yield strength of nonprestressed reinforcement, pounds per square inch (MPa).
- $h$  = overall thickness of member, inches (mm).
- $I_g$  = moment of inertia of gross concrete section about centroidal axis, neglecting reinforcement.
- $I_{se}$  = moment of inertia of reinforcement about centroidal axis of member cross section.
- $I_t$  = moment of inertia of structural steel shape, pipe or tubing about centroidal axis of composite member cross section.
- $k$  = effective length factor for compression members.
- $l_c$  = unsupported length of compression member.
- $l_u$  = unsupported length of compression member.
- $M_c$  = factored moment to be used for design of compression member.
- $M_u$  = factored moment at section.

- $M_{1b}$  = value of smaller factored end moment on a compression member due to the loads that result in no appreciable sideway, calculated by conventional elastic frame analysis; positive if bent in single curvature, negative if bent in double curvature.
- $M_{2b}$  = value of larger factored end moment on compression members due to loads which result in no appreciable sideway, calculated by conventional elastic frame analysis.
- $M_{2s}$  = value of larger factored end moment on compression member due to loads which result in appreciable sideway, calculated by conventional elastic frame analysis.
- $P_b$  = nominal axial load strength at balanced strain conditions. See Section 1910.3.2.
- $P_c$  = critical load. See Formula (10-9).
- $P_n$  = nominal axial load strength at given eccentricity.
- $P_o$  = nominal axial load strength at zero eccentricity.
- $P_u$  = factored axial load at given eccentricity  $\leq \phi P_n$ .
- $r$  = radius of gyration of cross section of a compression member.
- $z$  = quantity limiting distribution of flexural reinforcement. See Section 1910.6.
- $\beta_1$  = factor defined in Section 1910.2.7.3.
- $\beta_u$  = ratio of maximum factored axial dead load to maximum total factored axial load, where the load is due to gravity effects only in the calculations of  $P_c$  in Formula (10-7), or ratio of the maximum factored sustained lateral load to the maximum total factored lateral load in that story in the calculation of  $P_c$  in Formula (10-8).
- $\delta_b$  = moment magnification factor for frames braced against sideway to reflect effects of member curvature between ends of compression members.
- $\delta_s$  = moment magnification factor for frames not braced against sideway to reflect lateral drift resulting from lateral and gravity loads.
- $\rho$  = ratio of nonprestressed tension reinforcement.  
=  $A_s/bd$ .
- $\rho_b$  = reinforcement ratio producing balanced strain conditions. See Section 1910.3.2.
- $\rho_s$  = ratio of volume of spiral reinforcement to total volume of core (out-to-out of spirals) of a spirally reinforced compression member.
- $\phi$  = strength-reduction factor. See Section 1909.3.

**1910.1 Scope.** Provisions of Section 1910 shall apply for design of members subject to flexure or axial loads or to combined flexure and axial loads.

### 1910.2 Design Assumptions.

**1910.2.1** Strength design of members for flexure and axial loads shall be based on assumptions given in *the following items* and on satisfaction of applicable conditions of equilibrium and compatibility of strains.

**1910.2.2** Strain in reinforcement and concrete shall be assumed directly proportional to the distance from the neutral axis, except, for deep flexural members with overall depth-to-clear-span ratios greater than two fifths for continuous spans and four fifths for simple spans, a nonlinear distribution of strain shall be considered. See Section 1910.7.

**1910.2.3** Maximum usable strain at extreme concrete compression fiber shall be assumed equal to 0.003.

**1910.2.4** Stress in reinforcement below specified yield strength  $f_y$  for grade of reinforcement used shall be taken as  $E_s$  times steel strain. For strains greater than that corresponding to  $f_y$ , stress in reinforcement shall be considered independent of strain and equal to  $f_y$ .

**1910.2.5** Tensile strength of concrete shall be neglected in axial and flexural calculations of reinforced concrete, except where meeting requirements of Section 1918.4.

**1910.2.6** Relationship between concrete compressive stress distribution and concrete strain may be assumed to be rectangular, trapezoidal, parabolic or any other shape that results in prediction of strength in substantial agreement with results of comprehensive tests.

**1910.2.7** Requirements of Section 1910.2.6 may be considered satisfied by an equivalent rectangular concrete stress distribution defined by the following:

**1910.2.7.1** Concrete stress of  $0.85f'_c$  shall be assumed uniformly distributed over an equivalent compression zone bounded by edges of the cross section and a straight line located parallel to the neutral axis at a distance  $a = \beta_1 c$  from the fiber of maximum compressive strain.

**1910.2.7.2** Distance  $c$  from fiber of maximum strain to the neutral axis shall be measured in a direction perpendicular to the axis.

**1910.2.7.3** Factor  $\beta_1$  shall be taken as 0.85 for concrete strengths  $f'_c$  up to and including 4,000 psi (27.58 MPa). For strengths above 4,000 psi (27.58 MPa),  $\beta_1$  shall be reduced continuously at a rate of 0.05 for each 1,000 psi (6.89 MPa) of strength in excess of 4,000 psi (27.58 MPa), but  $\beta_1$  shall not be taken less than 0.65.

### 1910.3 General Principles and Requirements.

**1910.3.1** Design of cross section subject to flexure or axial loads or to combined flexure and axial loads shall be based on stress and strain compatibility using assumptions in Section 1910.2.

**1910.3.2** Balanced strain conditions exist at a cross section when tension reinforcement reaches the strain corresponding to its specified yield strength  $f_y$  just as concrete in compression reaches its assumed ultimate strain of 0.003.

**1910.3.3** For flexural members, and for members subject to combined flexure and compressive axial load when the design axial load strength  $\phi P_n$  is less than the smaller of  $0.10 f'_c A_g$  or  $\phi P_b$ , the ratio of reinforcement  $\rho$  provided shall not exceed 0.75 of the ratio  $\rho_b$  that would produce balanced strain conditions for the section under flexure without axial load. For members with compression reinforcement, the portion of  $\rho_b$  equalized by compression reinforcement need not be reduced by the 0.75 factor.

**1910.3.4** Compression reinforcement in conjunction with additional tension reinforcement may be used to increase the strength of flexural members.

**1910.3.5** Design axial load strength  $\phi P_n$  of compression members shall not be taken greater than the following:

**1910.3.5.1** For nonprestressed members with spiral reinforcement conforming to Section 1907.10.4 or composite members conforming to Section 1910.14:

$$\phi P_{n(max.)} = 0.85\phi[0.85f'_c (A_g - A_{st}) + f_y A_{st}] \quad (10-1)$$

**1910.3.5.2** For nonprestressed members with tie reinforcement conforming to Section 1907.10.5:

$$\phi P_{n(max.)} = 0.80\phi[0.85f'_c (A_g - A_{st}) + f_y A_{st}] \quad (10-2)$$

**1910.3.5.3** For prestressed members, design axial load strength  $\phi P_n$  shall not be taken greater than 0.85 (for members with spiral reinforcement) or 0.80 (for members with tie reinforcement) of the design axial load strength at zero eccentricity  $\phi P_o$ .

**1910.3.6** Members subject to compressive axial load shall be designed for the maximum moment that can accompany the axial load. The factored axial load  $P_u$  at given eccentricity shall not exceed that given in Section 1910.3.5. The maximum factored moment  $M_u$  shall be magnified for slenderness effects in accordance with Section 1910.10.

**1910.4 Distance between Lateral Supports of Flexural Members.**

**1910.4.1** Spacing of lateral supports for a beam shall not exceed 50 times the least width  $b$  of compression flange or face.

**1910.4.2** Effects of lateral eccentricity of load shall be taken into account in determining spacing of lateral supports.

**1910.5 Minimum Reinforcement of Flexural Members.**

**1910.5.1** At any section of a flexural member, except as provided *herein* where positive reinforcement is required by analysis, the ratio  $\rho$  provided shall not be less than that given by:

$$\rho \text{ min.} = \frac{200}{f_y} \quad (10-3)$$

For SI: 
$$\rho \text{ min.} = \frac{1.4}{f_y}$$

In T-beams and joists where the web is in tension, the ratio  $\rho$  shall be computed for this purpose using width of web.

**1910.5.2** Alternatively, area of reinforcement provided at every section, positive or negative, shall be at least one-third greater than that required by analysis.

**1910.5.3** For structural slabs of uniform thickness, minimum area and maximum spacing of reinforcement in the direction of the span shall be as required for shrinkage and temperature according to Section 1907.12.

**1910.6 Distribution of Flexural Reinforcement in Beams and One-way Slabs.**

**1910.6.1** The rules for distribution of flexural reinforcement to control flexural cracking in beams and in one-way slabs (slabs reinforced to resist flexural stresses in only one direction) are as follows:

**1910.6.2** Distribution of flexural reinforcement in two-way slabs shall be as required by Section 1913.4.

**1910.6.3** Flexural tension reinforcement shall be well distributed within maximum flexural tension zones of a member cross section as required by Section 1910.6.4.

**1910.6.4** When design yield strength  $f_y$  for tension reinforcement exceeds 40,000 psi (275.8 MPa), cross sections of maximum positive and negative moment shall be so proportioned that the quantity  $z$  given by

$$z = f_s \sqrt[3]{d_c A} \quad (10-4)$$

does not exceed 175 kips per inch (30.6 MN/m) for interior exposure and 145 kips per inch (25.4 MN/m) for exterior exposure. Calculated stress in reinforcement at service load  $f_s$  (kips per square inch) (MPa) shall be computed as the moment divided by the product of steel area and internal moment arm. In lieu of such computations, it is permitted to take  $f_s$  as 60 percent of specified yield strength  $f_y$ .

**1910.6.5** Provisions of Section 1910.6.4 may not be sufficient for structures subject to very aggressive exposure or designed to be watertight. For such structures, special investigations and precautions are required.

**1910.6.6** Where flanges of T-beam construction are in tension, part of the flexural tension reinforcement shall be distributed over an effective flange width as defined in Section 1908.10, or a width equal to one tenth the span, whichever is smaller. If the effective flange width exceeds one tenth the span, some longitudinal reinforcement shall be provided in the outer portions of the flange.

**1910.6.7** If the depth of the web exceeds 3 feet (914 mm), longitudinal skin reinforcement shall be uniformly distributed along both side faces of the member for a distance  $d/2$  nearest the flexural tension reinforcement. The area of skin reinforcement,  $A_{sk}$ , per foot (per mm) of height on each side face shall be  $\geq 0.012 (d - 30)$  [For SI:  $\geq 0.012 (d - 762)$ ]. The maximum spacing of the skin reinforcement shall not exceed the lesser of  $d/6$  and 12 inches (305 mm). Such reinforcement may be included in strength computations if a strain compatibility analysis is made to determine stresses in the individual bars or wires. The total area of longitudinal skin reinforcement in both faces need not exceed one half of the required flexural tensile reinforcement.

### 1910.7 Deep Flexural Members.

**1910.7.1** Flexural members with overall depth-to-clear-span ratios greater than two fifths for continuous spans, or four fifths for simple spans, shall be designed as deep flexural members, taking into account nonlinear distribution of strain and lateral buckling.

**1910.7.2** Shear strength of deep flexural members shall be in accordance with Section 1911.8.

**1910.7.3** Minimum flexural tension reinforcement shall conform to Section 1910.5.

**1910.7.4** Minimum horizontal and vertical reinforcement in the side faces of deep flexural members shall be the greater of the requirements of Sections 1911.8.8 and 1911.8.9 or Sections 1914.3.2 and 1914.3.3.

### 1910.8 Design Dimensions for Compression Members.

**1910.8.1 Isolated compression member with multiple spirals.** Outer limits of the effective cross section of a compression member with two or more interlocking spirals shall be taken at a distance outside the extreme limits of the spirals equal to the minimum concrete cover required by Section 1907.7.

**1910.8.2 Compression member built monolithically with wall.** Outer limits of the effective cross section of a spirally reinforced or tied reinforced compression member built monolithically with a concrete wall or pier shall be taken not greater than  $1\frac{1}{2}$  inches (38 mm) outside the spiral or tie reinforcement.

**1910.8.3 Equivalent circular compression member.** In lieu of using full gross area for design, a compression member with a square, octagonal or other shaped cross section may be considered as a circular section with a diameter equal to the least lateral dimension of the actual shape. Gross area considered, required percentage of reinforcement, and design strength shall be based on that circular section.

**1910.8.4 Limits of section.** For a compression member with a larger cross section than required by considerations of loading, a reduced effective area  $A_g$  not less than one half the total area may be used to determine minimum reinforcement and design strength.

### 1910.9 Limits for Reinforcement of Compression Members.

**1910.9.1** Area of longitudinal reinforcement for noncomposite compression members shall not be less than 0.01 or more than 0.08 times gross area  $A_g$  of section.

**1910.9.2** Minimum number of longitudinal bars in compression members shall be four for bars within rectangular or circular ties, three for bars within triangular ties, and six for bars enclosed by spirals conforming to *the following ratio*:

**1910.9.3** Ratio of spiral reinforcement  $\rho_s$  shall not be less than the value given by

$$\rho_s = 0.45 \left( \frac{A_g}{A_c} - 1 \right) \frac{f'_c}{f_y} \quad (10-5)$$

where  $f_y$  is the specified yield strength of spiral reinforcement but not more than 60,000 psi (413.7 MPa).

**1910.10 Slenderness Effects in Compression Members.**

**1910.10.1** Design of compression members shall be based on forces and moments determined from analysis of the structure. Such analysis shall take into account influence of axial loads and variable moment of inertia on member stiffness and fixed-end moments, effect of deflections on moments and forces and the effects of duration of loads.

**1910.10.2** In lieu of the procedure prescribed in Section 1910.10, slenderness effects in compression members may be evaluated in accordance with the approximate procedure presented in Section 1910.11.

**1910.10.3** The detailed requirements of Section 1910.11 need not be applied if slenderness effects in compression members are evaluated in accordance with Section 1910.10.

**1910.11 Approximate Evaluation of Slenderness Effects.****1910.11.1 Unsupported length of compression members.**

**1910.11.1.1** Unsupported length  $l_u$  of a compression member shall be taken as the clear distance between floor slabs, beams or other members capable of providing lateral support for that compression member.

**1910.11.1.2** Where column capitals or haunches are present, unsupported length shall be measured to the lower extremity of capital or haunch in the plan considered.

**1910.11.2 Effective length of compression members.**

**1910.11.2.1** For compression members braced against sidesway, effective length factor  $k$  shall be taken as 1.0, unless analysis shows that a lower value may be used.

**1910.11.2.2** For compression members not braced against sidesway, effective length factor  $k$  shall be determined with due consideration of effects of cracking and reinforcement on relative stiffness, and shall be greater than 1.0.

**1910.11.3 Radius of gyration.** Radius of gyration  $r$  may be taken equal to 0.30 times the overall dimension in the direction stability is being considered for rectangular compression members and 0.25 times the diameter for circular compression members. For other shapes,  $r$  may be computed for the gross concrete section.

**1910.11.4 Consideration of slenderness effects.**

**1910.11.4.1** For compression members braced against sidesway, effects of slenderness may be neglected when  $kl_u/r$  is less than  $34 - 12M_{1b}/M_{2b}$ .

**1910.11.4.2** For compression members not braced against sidesway, effects of slenderness may be neglected when  $kl_u/r$  is less than 22.

**1910.11.4.3** For all compression members with  $kl_u/r$  greater than 100, an analysis as defined in Section 1910.10.1 shall be made.

**1910.11.5 Moment magnification.**

**1910.11.5.1** Compression members shall be designed using the factored axial load  $P_u$  from a conventional frame analysis and a magnified factored moment  $M_c$  defined by:

$$M_c = \delta_b M_{2b} + \delta_s M_{2s} \quad (10-6)$$

**WHERE:**

$$\delta_b = \frac{C_m}{1 - \frac{P_u}{\phi P_c}} \geq 1.0 \quad (10-7)$$

$$\delta_s = \frac{1}{1 - \frac{\Sigma P_u}{\phi \Sigma P_c}} \geq 1.0 \quad (10-8)$$

AND

$$P_c = \frac{\pi^2 EI}{(kl_u)^2} \quad (10-9)$$

$\Sigma P_u$  and  $\Sigma P_c$  are the summations for all columns in a story. For frames not braced against sidesway, both  $\delta_b$  and  $\delta_s$  shall be computed. For frames braced against sidesways,  $\delta_s$  shall be taken as 1.0. In calculation of  $P_c$ ,  $k$  shall be computed according to Section 1910.11.2.1 for  $\delta_b$  and according to Section 1910.11.2.2 for  $\delta_s$ .

**1910.11.5.2** In lieu of a more accurate calculation,  $EI$  in Formula (10-9) may be taken either as

$$EI = \frac{(E_c I_g / 5) + E_s I_{se}}{1 + \beta_d} \quad (10-10)$$

or conservatively

$$EI = \frac{E_c I_g / 2.5}{1 + \beta_d} \quad (10-11)$$

**1910.11.5.3** In Formula (10-7), for members braced against sidesway and without transverse loads between supports,  $C_m$  may be taken as

$$C_m = 0.6 + 0.4 \frac{M_{1b}}{M_{2b}} \quad (10-12)$$

but not less than 0.4. For all other cases,  $C_m$  shall be taken as 1.0.

**1910.11.5.4** If computations show that there is no moment at both ends of a braced compression member or that computed end eccentricities are less than  $(0.6 + 0.03h)$  inches [For SI:  $(15.24 + 0.03h)$  mm],  $M_{2b}$  in Formula (10-6) shall be based on a minimum eccentricity of  $(0.6 + 0.03h)$  inches [For SI:  $(15.24 + 0.03h)$  mm] about each principal axis separately. Ratio  $M_{1b}/M_{2b}$  in Formula (10-12) shall be determined by either of the following:

1. When computed end eccentricities are less than  $(0.6 + 0.03h)$  inches [For SI:  $(15.24 + 0.03h)$  mm], computed end moments may be used to evaluate  $M_{1b}/M_{2b}$  in Formula (10-12).

2. If computations show that there is essentially no moment at both ends of a braced compression member, the ratio  $M_{1b}/M_{2b}$  shall be taken equal to one.

**1910.11.5.5** If computations show that there is no moment at both ends of a compression member not braced against sidesway or that computed end eccentricities are less than  $(0.6 + 0.03h)$  inches [For SI:  $(15.24 + 0.03h)$  mm],  $M_{2b}$  in Formula (10-6) shall be based on a minimum eccentricity of  $(0.6 + 0.03h)$  inches [For SI:  $(15.24 + 0.03h)$  mm], about each principal axis separately.

**1910.11.6 Moment magnification for flexural members.** In frames not braced against sidesway, flexural members shall be designed for the total magnified end moments of the compression members at the joint.

**1910.11.7 Moment magnifier  $\delta$  for biaxial bending.** For compression members subject to bending about both principal axes, moment about each axis shall be magnified by  $\delta$ , computed from corresponding conditions of restraint about that axis.

**1910.12 Axially Loaded Members Supporting Slab System.** Axially loaded members supporting slab system included within the scope of Section 1913.1 shall be designed as provided in Section 1910 and in accordance with the additional requirements of Section 1913.

**1910.13 Transmission of Column Loads through Floor System.** When the specified compressive strength of concrete in a column is greater than 1.4 times that specified for a floor system, transmission of load through the floor system shall be provided by one of the following:

**1910.13.1** Concrete of strength specified for the column shall be placed in the floor at the column location. Top surface of the column concrete shall extend 2 feet (610 mm) into the slab from face of column. Column concrete shall be well integrated with floor concrete, and shall be placed in accordance with Sections 1906.4.5 and 1906.4.6.

**1910.13.2** Strength of a column through a floor system shall be based on the lower value of concrete strength with vertical dowels and spirals as required.

**1910.13.3** For columns laterally supported on four sides by beams of approximately equal depth or by slabs, strength of the column may be based on an assumed concrete strength in the column joint equal to 75 percent of column concrete strength plus 35 percent of floor concrete strength.

#### 1910.14 Composite Compression Members.

**1910.14.1** Composite compression members shall include all such members reinforced longitudinally with structural steel shapes, pipe or tubing with or without longitudinal bars.

**1910.14.2** Strength of a composite member shall be computed for the same limiting conditions applicable to ordinary reinforced concrete members.

**1910.14.3** Any axial load strength assigned to concrete of a composite member shall be transferred to the concrete by members or brackets in direct bearing on the composite member concrete.

**1910.14.4** All axial load strength not assigned to concrete of a composite member shall be developed by direct connection to the structural steel shape, pipe or tube.

**1910.14.5** For evaluation of slenderness effects, radius of gyration of a composite section shall not be greater than the value given by:

$$r = \sqrt{\frac{(E_c I_g/5) + E_s I_t}{(E_c A_g/5) + E_s A_t}} \quad (10-13)$$

In lieu of a more accurate calculation,  $EI$  in Formula (10-9) may be taken either as Formula (10-11) or

$$EI = \frac{E_c I_g/5}{1 + \beta_d} + E_s I_t \quad (10-14)$$

#### 1910.14.6 Structural steel-encased concrete core.

**1910.14.6.1** For a composite member with concrete core encased by structural steel, thickness of the steel encasement shall not be less than

$$b \sqrt{\frac{f_y}{3E_s}}, \text{ for each face of width } b$$

nor

$$h \sqrt{\frac{f_y}{8E_s}}, \text{ for circular sections of diameter } h$$

**1910.14.6.2** Longitudinal bars located within the encased concrete core may be considered in computing  $A_t$  and  $I_t$ .

**1910.14.7 Spiral reinforcement around structural steel core.** A composite member with spirally reinforced concrete around a structural steel core shall conform to the following:

**1910.14.7.1** Specified compressive strength of concrete  $f'_c$  shall not be less than 2,500 psi (17.24 MPa).

**1910.14.7.2** Design yield strength of structural steel core shall be the specified minimum yield strength for grade of structural steel used but not to exceed 50,000 psi (344.7 MPa).

**1910.14.7.3** Spiral reinforcement shall conform to Section 1910.9.3.

**1910.14.7.4** Longitudinal bars located within the spiral shall not be less than 0.01 or more than 0.08 times net area of concrete section.

**1910.14.7.5** Longitudinal bars located within the spiral may be considered in computing  $A_t$  and  $I_t$ .

**1910.14.8 Tie reinforcement around structural steel core.** A composite member with laterally tied concrete around a structural steel core shall conform to the following:

**1910.14.8.1** Specified compressive strength of concrete  $f'_c$  shall not be less than 2,500 psi (17.24 MPa).

**1910.14.8.2** Design yield strength of structural steel core shall be the specified minimum yield strength for grade of structural steel used but not to exceed 50,000 psi (344.7 MPa).

**1910.14.8.3** Lateral ties shall extend completely around the structural steel core.

**1910.14.8.4** Lateral ties shall have a diameter not less than  $1/50$  times the greatest side dimension of composite member, except that ties shall not be smaller than No. 3 and need not be larger than No. 5. Welded wire fabric of equivalent area may be used.

**1910.14.8.5** Vertical spacing of lateral ties shall not exceed 16 longitudinal bar diameters, 48 tie bar diameters, or one half times the least side dimension of the composite member.

**1910.14.8.6** Longitudinal bars located within the ties shall not be less than 0.01 or more than 0.08 times net area of concrete section.

**1910.14.8.7** A longitudinal bar shall be located at every corner of a rectangular cross section, with other longitudinal bars spaced not farther apart than one half the least side dimension of the composite member.

**1910.14.8.8** Longitudinal bars located within the ties may be considered in computing  $A_t$  for strength but not in computing  $I_t$  for evaluation of slenderness effects.

### 1910.15 Bearing Strength.

**1910.15.1** Design bearing strength on concrete shall not exceed  $\phi (0.85f'_c A_1)$ , except when the supporting surface is wider on all sides than the loaded area, design bearing strength on the loaded area may be multiplied by  $\sqrt{A_2/A_1}$ , but not more than 2.

**1910.15.2** *This section does not apply to posttensioning anchorages.*

## SECTION 1911 — SHEAR AND TORSION

### 1911.0 Notations.

$A_c$  = area of concrete section resisting shear transfer, square inches ( $\text{mm}^2$ ).

$A_f$  = area of reinforcement in bracket or corbel resisting factored moment [ $V_u a + N_{uc} (h-d)$ ], square inches ( $\text{mm}^2$ ).

$A_g$  = gross area of section, square inches ( $\text{mm}^2$ ).

$A_h$  = area of shear reinforcement parallel to flexural tension reinforcement, square inches ( $\text{mm}^2$ ).

$A_t$  = total area of longitudinal reinforcement to resist torsion, square inches ( $\text{mm}^2$ ).

$A_n$  = area of reinforcement in bracket or corbel resisting tensile force  $N_{uc}$ , square inches ( $\text{mm}^2$ ).

$A_{ps}$  = area of prestressed reinforcement in tension zone, square inches ( $\text{mm}^2$ ).

- $A_s$  = area of nonprestressed tension reinforcement, square inches ( $\text{mm}^2$ ).  
 $A_t$  = area of one leg of a closed stirrup resisting torsion within a distance  $s$ , square inches ( $\text{mm}^2$ ).  
 $A_v$  = area of shear reinforcement within a distance  $s$ , or area of shear reinforcement perpendicular to flexural tension reinforcement within a distance  $s$  for deep flexural members, square inches ( $\text{mm}^2$ ).  
 $A_{vf}$  = area of shear-friction reinforcement, square inches ( $\text{mm}^2$ ).  
 $A_{vh}$  = area of shear reinforcement parallel to flexural tension reinforcement within a distance  $s_2$ , square inches ( $\text{mm}^2$ ).  
 $a$  = shear span, distance between concentrated load and face of supports.  
 $b$  = width of compression face of member, inches (mm).  
 $b_o$  = perimeter of critical section for slabs and footings, inches (mm).  
 $b_t$  = width of that part of cross section containing the closed stirrups resisting torsion.  
 $b_w$  = web width, or diameter of circular section, inches (mm).  
 $C_t$  = factor relating shear and torsional stress properties.  

$$= \frac{b_w d}{\sum x^2 y}$$
  
 $c_1$  = size of rectangular or equivalent rectangular column, capital or bracket measured in the direction of the span for which moments are being determined, inches (mm).  
 $c_2$  = size of rectangular or equivalent rectangular column, capital or bracket measured transverse to the direction of the span for which moments are being determined, inches (mm).  
 $d$  = distance from extreme compression fiber to centroid of longitudinal tension reinforcement, but need not be less than  $0.80h$  for prestressed members, inches (mm). (For circular sections,  $d$  need not be less than the distance from extreme compression fiber to centroid of tension reinforcement in opposite half of member.)  
 $f'_c$  = specified compressive strength of concrete, pounds per square inch (MPa).  
 $\sqrt{f'_c}$  = square root of specified compressive strength of concrete, pounds per square inch (MPa).  
 $f_{ct}$  = average splitting tensile strength of lightweight aggregate concrete, pounds per square inch (MPa).  
 $f_d$  = stress due to unfactored dead load, at extreme fiber of section where tensile stress is caused by externally applied loads, pounds per square inch (MPa).  
 $f_{pc}$  = compressive stress in concrete (after allowance for all prestress losses) at centroid of cross section resisting externally applied loads or at junction of web and flange when the centroid lies within the flange, pounds per square inch (MPa). (In a composite member,  $f_{pc}$  is resultant compressive stress at centroid of composite section, or at junction of web and flange when the centroid lies within the flange, due to both prestress and moments resisted by precast member acting alone.)  
 $f_{pe}$  = compressive stress in concrete due to effective prestress forces only (after allowance for all prestress losses) at extreme fiber of section where tensile stress is caused by externally applied loads, pounds per square inch (MPa).  
 $f_{pu}$  = specified tensile strength of prestressing tendons, pounds per square inch (MPa).  
 $f_y$  = specified yield strength of nonprestressed reinforcement, pounds per square inch (MPa).  
 $h$  = overall thickness of member, inches (mm).  
 $h_v$  = total depth of shearhead cross section, inches (mm).  
 $h_w$  = total height of wall from base to top, inches (mm).  
 $I$  = moment of inertia of section resisting externally applied factored loads.

- $l_n$  = clear span measured face to face of supports.  
 $l_v$  = length of shearhead arm from centroid of concentrated load or reaction, inches (mm).  
 $l_w$  = horizontal length of wall, inches (mm).  
 $M_{cr}$  = moment causing flexural cracking at section due to externally applied loads. See Section 1911.4.2.1.  
 $M_m$  = modified moment.  
 $M_{max}$  = maximum factored moment at section due to externally applied loads.  
 $M_p$  = required plastic moment strength of shearhead cross section.  
 $M_u$  = factored moment at section.  
 $M_v$  = moment resistance contributed by shearhead reinforcement.  
 $N_u$  = factored axial load normal to cross section occurring simultaneously with  $V_u$ ; to be taken as positive for compression, negative for tension, and to include effects of tension due to creep and shrinkage.  
 $N_{uc}$  = factored tensile force applied at top of bracket or corbel acting simultaneously with  $V_u$  to be taken as positive for tension.  
 $s$  = spacing of shear or torsion reinforcement in direction parallel to longitudinal reinforcement, inches (mm).  
 $s_1$  = spacing of vertical reinforcement in wall, inches (mm).  
 $s_2$  = spacing of shear or torsion reinforcement in direction perpendicular to longitudinal reinforcement—or spacing of horizontal reinforcement in wall, inches (mm).  
 $T_c$  = nominal torsional moment strength provided by concrete.  
 $T_n$  = nominal torsional moment strength.  
 $T_s$  = nominal torsional moment strength provided by torsion reinforcement. See Section 1911.6.9.1.  
 $T_u$  = factored torsional moment at section.  
 $V_c$  = nominal shear strength provided by concrete.  
 $V_{ci}$  = nominal shear strength provided by concrete when diagonal cracking results from combined shear and moment.  
 $V_{cw}$  = nominal shear strength provided by concrete when diagonal cracking results from excessive principal tensile stress in web.  
 $V_d$  = shear force at section due to unfactored dead load.  
 $V_i$  = factored shear force at section due to externally applied loads occurring simultaneously with  $M_{max}$ .  
 $V_n$  = nominal shear strength.  
 $V_p$  = vertical component of effective prestress force at section.  
 $V_s$  = nominal shear strength provided by shear reinforcement.  
 $V_u$  = factored shear force at section.  
 $v_n$  = nominal shear stress, pounds per square inch (MPa).  
 $x$  = shorter overall dimension of rectangular part of cross section.  
 $x_1$  = shorter center-to-center dimension of closed rectangular stirrup.  
 $y$  = longer overall dimension of rectangular part of cross section.  
 $y_1$  = longer center-to-center dimension of closed rectangular stirrup.  
 $y_t$  = distance from centroidal axis of gross section, neglecting reinforcement, to extreme fiber in tension.  
 $\alpha$  = angle between included stirrups and longitudinal axis of member.

- $\alpha_f$  = angle between shear-friction reinforcement and shear plane.  
 $\alpha_s$  = constant used to compute  $V_c$  in slabs.  
 $\alpha_t$  = coefficient as a function of  $y_1/x_1$ . See Section 1911.6.9.1.  
 $\alpha_w$  = ratio of stiffness of shearhead arm to surrounding composite slab section.  
 $\beta_c$  = ratio of long side to short side of concentrated load or reaction area.  
 $\beta_d$  = constant used to compute  $V_c$  in prestressed slabs.  
 $\gamma_f$  = fraction of unbalanced moment transferred by flexure at slab-column connection. See Section 1913.3.4.  
 $\gamma_w$  = fraction of unbalanced moment transferred by eccentricity of shear at slab-column connections. See Section 1911.12.6.1.  
     =  $1 - \gamma_f$ .  
 $\eta$  = number of identical arms of shearhead.  
 $\mu$  = coefficient of friction. See Section 1911.7.4.3.  
 $\lambda$  = correction factor related to unit weight of concrete.  
 $\rho$  = ratio of nonprestressed tension reinforcement.  
     =  $A_s/bd$ .  
 $\rho_h$  = ratio of horizontal shear reinforcement area to gross concrete area of vertical section.  
 $\rho_n$  = ratio of vertical shear reinforcement area to gross concrete area of horizontal section.  
 $\rho_w$  =  $A_s/b_wd$ .  
 $\Sigma x^2y$  = torsional section properties. See Sections 1911.6.1.1 and 1911.6.1.2.  
 $\phi$  = strength-reduction factor. See Section 1909.3.

### 1911.1 Shear Strength.

1911.1.1 Design of cross sections subject to shear shall be based on

$$V_u \leq \phi V_n \quad (11-1)$$

where  $V_u$  is factored shear force at section considered and  $V_n$  is nominal shear strength computed by

$$V_n = V_c + V_s \quad (11-2)$$

where  $V_c$  is nominal shear strength provided by concrete in accordance with Section 1911.3 or Section 1911.4, and  $V_s$  is nominal shear strength provided by shear reinforcement in accordance with Section 1911.5.6.

1911.1.1.1 In determining shear strength  $V_n$ , the effect of any openings in members shall be considered.

1911.1.1.2 In determining shear strength  $V_c$ , whenever applicable, effects of axial tension due to creep and shrinkage in restrained members shall be considered and effects of inclined flexural compression in variable-depth members may be included.

1911.1.2 The values of  $\sqrt{f'_c}$  used in Section 1911 shall not exceed 100 psi (0.69 MPa).

**EXCEPTION:** Values of  $\sqrt{f'_c}$  greater than 100 psi (0.69 MPa) is allowed in computing  $V_c$ ,  $V_{ci}$  and  $V_{cw}$  for reinforced or prestressed concrete beams and concrete joist construction having minimum web reinforcement equal to  $f'_c/5,000$  ( $f'_c/34.47$ ) times, but not more than three times the amounts required by Sections 1911.5.5.3, 1911.5.5.4 and 1911.5.5.5.

1911.1.3 Maximum factored shear force  $V_u$  at supports may be computed in accordance with this section when both of the following two conditions are satisfied:

1. Support reaction, in direction of applied shear, introduces compression into the end regions of member, and

2. No concentrated load occurs between face of support and location of critical section defined in *this section*.

**1911.1.3.1** For nonprestressed members, sections located less than a distance  $d$  from face of support may be designed for the same shear  $V_u$  as that computed at a distance  $d$ .

**1911.1.3.2** For prestressed members, sections located less than a distance  $h/2$  from face of support may be designed for the same shear  $V_u$  as that computed at a distance  $h/2$ .

**1911.1.4** For deep flexural members, brackets and corbels, walls and slabs and footings, the special provisions of Sections 1911.8 through 1911.12 shall apply.

### 1911.2 Lightweight Concrete.

**1911.2.1** Provisions for shear strength  $V_c$  and torsional moment strength  $T_c$  apply to normal-weight concrete. When lightweight aggregate concrete is used, one of the following modifications shall apply:

**1911.2.1.1** When  $f_{ct}$  is specified and concrete is proportioned in accordance with Section 1905.2, provisions for  $V_c$  and  $T_c$  shall be modified by substituting  $f_{ct}/6.7$  (For SI:  $1.8 \sqrt{f'_c}$ ) for  $\sqrt{f'_c}$ , but the value of  $f_{ct}/6.7$  (For SI:  $1.8 \sqrt{f'_c}$ ) shall not exceed  $\sqrt{f'_c}$ .

**1911.2.1.2** When  $f_{ct}$  is not specified, all values of  $\sqrt{f'_c}$  affecting  $V_c$ ,  $T_c$  and  $M_{cr}$  shall be multiplied by 0.75 for all-lightweight concrete and 0.85 for sand-lightweight concrete. Linear interpolation may be used when partial sand replacement is used.

### 1911.3 Shear Strength Provided by Concrete for Nonprestressed Members.

**1911.3.1** Shear strength  $V_c$  shall be computed by provisions of Sections 1911.3.1.1 through 1911.3.1.4 unless a more detailed calculation is made in accordance with Section 1911.3.2.

**1911.3.1.1** For members subject to shear and flexure only,

$$V_c = 2\sqrt{f'_c} b_w d \quad (11-3)$$

For SI:  $V_c = 0.166 \sqrt{f'_c} b_w d$

**1911.3.1.2** For members subject to axial compression,

$$V_c = 2 \left( 1 + \frac{N_u}{2,000 A_g} \right) \sqrt{f'_c} b_w d \quad (11-4)$$

For SI:  $V_c = 0.166 \left( 1 + 0.073 \frac{N_u}{A_g} \right) \sqrt{f'_c} b_w d$

Quantity  $N_u/A_g$  shall be expressed in psi (MPa).

**1911.3.1.3** For members subject to significant axial tension, shear reinforcement shall be designed to carry total shear.

**1911.3.1.4** At sections where factored torsional moment  $T_u$  exceeds  $\phi (0.5 \sqrt{f'_c} \Sigma x^2 y)$  [For SI:  $\phi (0.042 \sqrt{f'_c} \Sigma x^2 y)$ ],

$$V_c = \frac{2\sqrt{f'_c} b_w d}{\sqrt{\left[ 1 + \left( 2.5 C_i \frac{T_u}{V_u} \right)^2 \right]}} \quad (11-5)$$

$$\text{For SI:} \quad V_c = \frac{0.166 \sqrt{f'_c} b_w d}{\sqrt{\left[1 + \left(2.5 C_i \frac{T_u}{V_u}\right)^2\right]}}$$

**1911.3.2** Shear strength  $V_c$  may be computed by the more detailed calculation of Sections 1911.3.2.1 through 1911.3.2.3.

**1911.3.2.1** For members subject to shear and flexure only,

$$V_c = \left(1.9 \sqrt{f'_c} + 2,500 \rho_w \frac{V_u d}{M_u}\right) b_w d \quad (11-6)$$

$$\text{For SI:} \quad V_c = \left(0.158 \sqrt{f'_c} + 17.1 \rho_w \frac{V_u d}{M_u}\right) b_w d$$

but not greater than  $3.5 \sqrt{f'_c} b_w d$  (For SI:  $0.29 \sqrt{f'_c} b_w d$ ). Quantity  $V_u d/M_u$  shall not be taken greater than 1.0 in computing  $V_c$  by Formula (11-6), where  $M_u$  is factored moment occurring simultaneously with  $V_u$  at section considered.

**1911.3.2.2** For members subject to axial compression, Formula (11-6) may be used to compute  $V_c$  with  $M_m$  substituted for  $M_u$  and  $V_u d/M_u$  not then limited to 1.0, where

$$M_m = M_u - N_u \frac{(4h - d)}{8} \quad (11-7)$$

However,  $V_c$  shall not be taken greater than

$$V_c = 3.5 \sqrt{f'_c} b_w d \sqrt{1 + \frac{N_u}{500 A_g}} \quad (11-8)$$

$$\text{For SI:} \quad V_c = 0.29 \sqrt{f'_c} b_w d \sqrt{1 + 0.29 \frac{N_u}{A_g}}$$

Quantity  $N_u/A_g$  shall be expressed in psi (MPa). When  $M_m$  as computed by Formula (11-7) is negative,  $V_c$  shall be computed by Formula (11-8).

**1911.3.2.3** For members subject to significant axial tension,

$$V_c = 2 \left(1 + \frac{N_u}{500 A_g}\right) \sqrt{f'_c} b_w \quad (11-9)$$

$$\text{For SI:} \quad V_c = 0.166 \left(1 + 0.29 \frac{N_u}{A_g}\right) \sqrt{f'_c} b_w d$$

where  $N_u$  is negative for tension. Quantity  $N_u/A_g$  shall be expressed in psi (MPa).

#### **1911.4 Shear Strength Provided by Concrete for Prestressed Members.**

**1911.4.1** For members with effective prestress force not less than 40 percent of the tensile strength of flexural reinforcement, unless a more detailed calculation is made in accordance with Section 1911.4.2.

$$V_c = \left(0.6 \sqrt{f'_c} + 700 \frac{V_u d}{M_u}\right) b_w d \quad (11-10)$$

$$\text{For SI:} \quad V_c = \left(0.05 \sqrt{f'_c} + 4.8 \frac{V_u d}{M_u}\right) b_w d$$

but  $V_c$  need not be taken less than  $2\sqrt{f'_c} b_w d$  (For SI:  $0.166\sqrt{f'_c} b_w d$ ) nor shall  $V_c$  be taken greater than  $5\sqrt{f'_c} b_w d$  (For SI:  $0.42\sqrt{f'_c} b_w d$ ) or the value given in Section 1911.4.3 or 1911.4.4. The quantity  $V_u d/M_u$  shall not be taken greater than 1.0, where  $M_u$  is factored moment occurring simultaneously with  $V_u$  at section considered. When applying Formula (11-10),  $d$  in the term  $V_u d/M_u$  shall be the distance from extreme compression fiber to centroid of prestressed reinforcement.

**1911.4.2** Shear strength  $V_c$  may be computed in accordance with Sections 1911.4.2.1 and 1911.4.2.2 where  $V_c$  shall be the lesser of  $V_{ci}$  or  $V_{cw}$ .

**1911.4.2.1** Shear strength  $V_{ci}$  shall be computed by

$$V_{ci} = 0.6\sqrt{f'_c} b_w d + V_d + \frac{V_i M_{cr}}{M_{max}} \quad (11-11)$$

For SI: 
$$V_{ci} = 0.05\sqrt{f'_c} b_w d + V_d + \frac{V_i M_{cr}}{M_{max}}$$

but  $V_{ci}$  need not be taken less than  $1.7\sqrt{f'_c} b_w d$  ( $0.14\sqrt{f'_c} b_w d$ ), where

$$M_{cr} = (I/y_i) (6\sqrt{f'_c} + f_{pe} - f_d) \quad (11-12)$$

For SI: 
$$M_{cr} = (I/y_i) (0.5\sqrt{f'_c} + f_{pe} - f_d)$$

and values of  $M_{max}$  and  $V_i$  shall be computed from the load combination causing maximum moment to occur at the section.

**1911.4.2.2** Shear strength  $V_{cw}$  shall be computed by

$$V_{cw} = (3.5\sqrt{f'_c} + 0.3f_{pc}) b_w d + V_p \quad (11-13)$$

For SI: 
$$V_{cw} = (0.29\sqrt{f'_c} + 0.3f_{pc}) b_w d + V_p$$

Alternatively,  $V_{cw}$  may be computed as the shear force corresponding to dead load plus live load that results in a principal tensile stress of  $4\sqrt{f'_c}$  (For SI:  $0.33\sqrt{f'_c}$ ) at centroidal axis of member, or at intersection of flange and web when centroidal axis is in the flange. In composite members, principal tensile stress shall be computed using the cross section that resists live load.

**1911.4.2.3** In Formulas (11-11) and (11-13),  $d$  shall be the distance from extreme compression fiber to centroid of prestressed reinforcement or  $0.8h$ , whichever is greater.

**1911.4.3** In a pretensioned member in which the section at a distance  $h/2$  from face of support is closer to end of member than the transfer length of the prestressing tendons, the reduced prestress shall be considered when computing  $V_{cw}$ . This value of  $V_{cw}$  shall also be taken as the maximum limit for Formula (11-10). Prestress force may be assumed to vary linearly from zero at end of tendon to a maximum at a distance from end of tendon equal to the transfer length, assumed to be 50 diameters for strand and 100 diameters for single wire.

**1911.4.4** In a pretensioned member where bonding of some tendons does not extend to end of member, a reduced prestress shall be considered when computing  $V_c$  in accordance with Section 1911.4.1 or 1911.4.2. Value of  $V_{cw}$  calculated using the reduced prestress shall also be taken as the maximum limit for Formula (11-10). Prestress force due to tendons for which bonding does not extend to end of member may be assumed to vary linearly from zero at the point at which bonding commences to a maximum at a distance from this point equal to the transfer length, assumed to be 50 diameters for strand and 100 diameters for single wire.

**1911.5 Shear Strength Provided by Shear Reinforcement.****1911.5.1 Types of shear reinforcement.**

**1911.5.1.1** Shear reinforcement may consist of:

1. Stirrups perpendicular to axis of member.
2. Welded wire fabric with wires located perpendicular to axis of member.

**1911.5.1.2** For nonprestressed members, shear reinforcement may also consist of:

1. Stirrups making an angle of 45 degrees or more with longitudinal tension reinforcement.
2. Longitudinal reinforcement with bent portion making an angle of 30 degrees or more with the longitudinal tension reinforcement.
3. Combination of stirrups and bent longitudinal reinforcement.
4. Spirals.

**1911.5.2** Design yield strength of shear reinforcement shall not exceed 60,000 psi (413.7 MPa).

**1911.5.3** Stirrups and other bars or wires used as shear reinforcement shall extend to a distance  $d$  from extreme compression fiber and shall be anchored at both ends according to Section 1912.13 to develop the design yield strength of reinforcement.

**1911.5.4 Spacing limits for shear reinforcement.**

**1911.5.4.1** Spacing of shear reinforcement placed perpendicular to axis of member shall not exceed  $d/2$  in nonprestressed members and  $(3/4)h$  in prestressed members or 24 inches (610 mm).

**1911.5.4.2** Inclined stirrups and bent longitudinal reinforcement shall be so spaced that every 45-degree line, extending toward the reaction from middepth of member  $d/2$  to longitudinal tension reinforcement, shall be crossed by at least one line of shear reinforcement.

**1911.5.4.3** When  $V_s$  exceeds  $4\sqrt{f'_c}b_wd$  (For SI:  $0.33\sqrt{f'_c}b_wd$ ), maximum spacings given in the paragraphs above shall be reduced by one half.

**1911.5.5 Minimum shear reinforcement.**

**1911.5.5.1** A minimum area of shear reinforcement shall be provided in all reinforced concrete flexural members (prestressed and nonprestressed) where factored shear force  $V_u$  exceeds one half the shear strength provided by concrete  $\phi V_c$ , except:

1. Slabs and footings.
2. Concrete joist construction defined by Section 1908.11.
3. Beams with total depth not greater than 10 inches (254 mm), two and one half times thickness of flange or one half the width of web, whichever is greater.

**1911.5.5.2** Minimum shear reinforcement requirements of Section 1911.5.5.1 may be waived if shown by test that required nominal flexural and shear strengths can be developed when shear reinforcement is omitted. Such tests shall simulate effects of differential settlement, creep, shrinkage and temperature change, based on a realistic assessment of such effects occurring in service.

**1911.5.5.3** Where shear reinforcement is required by Section 1911.5.5.1 or by analysis, and where factored torsional moment  $T_u$  does not exceed  $\phi(0.5\sqrt{f'_c}\Sigma x^2y)$  [For SI:  $\phi(0.042\sqrt{f'_c}\Sigma x^2y)$ ], minimum area of shear reinforcement for prestressed (except as provided in Section 1911.5.5.4) and nonprestressed members shall be computed by

$$A_v = 50 \frac{b_w s}{f_y} \quad (11-14)$$

For SI: 
$$A_v = 0.34 \frac{b_w s}{f_y}$$

where  $b_w$  and  $s$  are in inches.

**1911.5.5.4** For prestressed members with effective prestress force not less than 40 percent of the tensile strength of flexural reinforcement, the area of shear reinforcement shall not be less than the smaller  $A_v$ , computed by Formula (11-14) or (11-15).

$$A_v = \frac{A_{ps} f_{pu}}{80 f_y} \frac{s}{d} \sqrt{\frac{d}{b_w}} \quad (11-15)$$

**1911.5.5.5** Where factored torsional moment  $T_u$  exceeds  $\phi (0.5 \sqrt{f'_c} \Sigma x^2 y)$  [For SI:  $\phi (0.042 \sqrt{f'_c} \Sigma x^2 y)$ ], and where web reinforcement is required by Section 1911.5.5.1 or by analysis, minimum area of closed stirrups shall be computed by

$$A_v + 2A_t = 50 \frac{b_w s}{f_y} \quad (11-16)$$

For SI: 
$$A_v + 2A_t = 0.34 \frac{b_w s}{f_y}$$

#### 1911.5.6 Design of shear reinforcement.

**1911.5.6.1** Where factored shear force  $V_u$  exceeds shear strength  $\phi V_c$ , shear reinforcement shall be provided to satisfy Formulas (11-1) and (11-2), where shear strength  $V_s$  shall be computed in accordance with Sections 1911.5.6.2 through 1911.5.6.8.

**1911.5.6.2** When shear reinforcement perpendicular to axis of member is used,

$$V_s = \frac{A_v f_y d}{s} \quad (11-17)$$

where  $A_v$  is the area of shear reinforcement within a distance  $s$ .

**1911.5.6.3** When inclined stirrups are used as shear reinforcement,

$$V_s = \frac{A_v f_y (\sin \alpha + \cos \alpha) d}{s} \quad (11-18)$$

**1911.5.6.4** When shear reinforcement consists of a single bar or a single group of parallel bars, all bent up at the same distance from the support,

$$V_s = A_v f_y \sin \alpha \quad (11-19)$$

but not greater than  $3 \sqrt{f'_c} b_w d$  (For SI:  $0.25 \sqrt{f'_c} b_w d$ ).

**1911.5.6.5** When shear reinforcement consists of a series of parallel bent-up bars or groups of parallel bent-up bars at different distances from the support, shear strength  $V_s$  shall be computed by Formula (11-18).

**1911.5.6.6** Only the center three fourths of the inclined portion of any longitudinal bent bar shall be considered effective for shear reinforcement.

**1911.5.6.7** Where more than one type of shear reinforcement is used to reinforce the same portion of a member, shear strength  $V_s$  shall be computed as the sum of the  $V_s$  values computed for the various types.

**1911.5.6.8** Shear strength  $V_s$  shall not be taken greater than  $8 \sqrt{f'_c} b_w d$  (For SI:  $0.66 \sqrt{f'_c} b_w d$ ).

#### 1911.6 Combined Shear and Torsion Strength for Nonprestressed Members with Rectangular or Flanged Sections.

**1911.6.1** Torsion effects shall be included with shear and flexure where factored torsional moment  $T_u$  exceeds  $\phi (0.5 \sqrt{f'_c} \Sigma x^2 y)$  [For SI:  $\phi (0.042 \sqrt{f'_c} \Sigma x^2 y)$ ]. Otherwise, torsion effects may be neglected.

**1911.6.1.1** For members with rectangular or flanged sections, the sum  $\Sigma x^2y$  shall be taken for the component rectangles of the section, but the overhanging flange width used in design shall not exceed three times the flange thickness.

**1911.6.1.2** A rectangular box section may be taken as a solid section, provided wall thickness  $h$  is at least  $x/4$ . A box section with wall thickness less than  $x/4$  but greater than  $x/10$  may also be taken as a solid section, except that  $\Sigma x^2y$  shall be multiplied by  $4h/x$ . When  $h$  is less than  $x/10$ , stiffness of wall shall be considered. Fillets shall be provided at interior corners of all box sections.

**1911.6.2** If the factored torsional moment  $T_u$  in a member is required to maintain equilibrium, the member shall be designed to carry that torsional moment in accordance with Sections 1911.6.4 through 1911.6.9.

**1911.6.3** In a statically indeterminate structure where reduction of torsional moment in a member can occur due to redistribution of internal forces, maximum factored torsional moment  $T_u$  may be reduced to  $\phi (4 \sqrt{f'_c} \Sigma x^2y/3)$  [For SI:  $\phi (0.33 \sqrt{f'_c} \Sigma x^2y/3)$ ].

**1911.6.3.1** In such a case, the correspondingly adjusted moments and shears in adjoining members shall be used in design.

**1911.6.3.2** In lieu of more exact analysis, torsional loading from a slab shall be taken as uniformly distributed along the member.

**1911.6.4** Sections located less than a distance  $d$  from face of support may be designed for the same torsional moment  $T_u$  as that computed at a distance  $d$ . If a concentrated torque occurs within this distance, the critical section for design shall be at the face of the support.

**1911.6.5 Torsional moment strength.** Design of cross sections subject to torsion shall be based on

$$T_u \leq \phi T_n \quad (11-20)$$

Where  $T_u$  is factored torsional moment at section considered and  $T_n$  is nominal torsional moment strength computed by

$$T_n = T_c + T_s \quad (11-21)$$

where  $T_c$  is nominal torsional moment strength provided by concrete in accordance with Section 1911.6.6 and  $T_s$  is nominal torsional moment strength provided by torsion reinforcement in accordance with Section 1911.6.9.

**1911.6.6 Torsional moment strength provided by concrete.**

**1911.6.6.1** Torsional moment strength  $T_c$  shall be computed by

$$T_c = \frac{0.8 \sqrt{f'_c} \Sigma x^2y}{\sqrt{1 + \left(\frac{0.4V_u}{C_r T_u}\right)^2}} \quad (11-22)$$

For SI:

$$T_c = \frac{0.066 \sqrt{f'_c} \Sigma x^2y}{\sqrt{1 + \left(\frac{0.4V_u}{C_r T_u}\right)^2}}$$

**1911.6.6.2** For members subject to significant axial tension, torsion reinforcement shall be designed to carry the total torsional moment, unless a more detailed calculation is made in which  $T_c$  is given by Formula (11-22) and  $V_c$  given by Formula (11-5) shall be multiplied by  $(1 + N_u/500A_g)$  [For SI:  $(1 + 0.29 N_u/A_g)$ ], where  $N_u$  is negative for tension.

**1911.6.7 Torsion reinforcement requirements.**

**1911.6.7.1** Torsion reinforcement, where required, shall be provided in addition to reinforcement required to resist shear, flexure and axial forces.

**1911.6.7.2** Reinforcement required for torsion may be combined with that required for other forces, provided the area furnished is the sum of individually required areas and the most restrictive requirements for spacing and placement are met.

**1911.6.7.3** Torsion reinforcement shall consist of closed stirrups, closed ties or spirals, combined with longitudinal bars.

**1911.6.7.4** Design yield strength of torsion reinforcement shall not exceed 60,000 psi (413.7 MPa).

**1911.6.7.5** Stirrups and other bars and wires used as torsion reinforcement shall extend to a distance  $d$  from extreme compression fiber and shall be anchored according to Section 1912.13 to develop the design yield strength of reinforcement.

**1911.6.7.6** Torsion reinforcement shall be provided at least a distance  $(b_t + d)$  beyond the point theoretically required.

**1911.6.8 Spacing limits for torsion reinforcement.**

**1911.6.8.1** Spacing of closed stirrups shall not exceed the smaller of  $(x_1 + y_1)/4$  or 12 inches (305 mm).

**1911.6.8.2** Spacing of longitudinal bars, not less than No. 3, distributed around the perimeter of the closed stirrups, shall not exceed 12 inches (305 mm). At least one longitudinal bar shall be placed in each corner of the closed stirrups.

**1911.6.9 Design of torsion reinforcement.**

**1911.6.9.1** Where factored torsional moment  $T_u$  exceeds torsional moment strength  $\phi T_c$ , torsion reinforcement shall be provided to satisfy Formulas (11-20) and (11-21), where torsional moment strength  $T_c$  shall be computed by

$$T_s = \frac{A_t \alpha_t x_1 y_1 f_y}{s} \quad (11-23)$$

where  $A_t$  is the area of one leg of a closed stirrup resisting torsion within a distance  $s$ , and  $\alpha_t = [0.66 + 0.33 (y_1/x_1)]$  but not more than 1.50. Longitudinal bars distributed around the perimeter of the closed stirrups  $A_t$  shall be provided in accordance with Section 1911.6.9.3.

**1911.6.9.2** A minimum area of closed stirrups shall be provided in accordance with Section 1911.5.5.5.

**1911.6.9.3** Required area of longitudinal bars  $A_l$  distributed around the perimeter of the closed stirrups  $A_t$  shall be computed by

$$A_l = 2A_t \left( \frac{x_1 + y_1}{s} \right) \quad (11-24)$$

or by

$$A_l = \left[ \frac{400xs}{f_y} \left( \frac{T_u}{T_u + \frac{V_u}{3C_t}} \right) - 2A_t \right] \left( \frac{x_1 + y_1}{s} \right) \quad (11-25)$$

For SI:

$$A_l = \left[ \frac{2.76xs}{f_y} \left( \frac{T_u}{T_u + \frac{V_u}{3C_t}} \right) - 2A_t \right] \left( \frac{x_1 + y_1}{s} \right)$$

whichever is greater. Value of  $A_t$  computed by Formula (11-25) need not exceed that obtained by substituting

$$\frac{50b_w s}{f_y} \text{ for } 2A_t$$

For SI:

$$\frac{0.34b_w s}{f_y} \text{ for } 2A_t$$

**1911.6.9.4** Torsional moment strength  $T_s$  shall not exceed  $4 T_c$ .

### 1911.7 Shear-friction.

**1911.7.1** The following provisions shall be applied where it is appropriate to consider shear transfer across a given plane, such as an existing or potential crack, an interface between dissimilar materials, or an interface between two concretes cast at different times.

**1911.7.2** Design of cross sections subject to shear transfer as described in Section 1911.7 shall be based on Formula (11-1) where  $V_n$  is calculated in accordance with provisions of Section 1911.7.3 or 1911.7.4.

**1911.7.3** A crack shall be assumed to occur along the shear plane considered. Required area of shear-friction reinforcement  $A_{vf}$  across the shear plane may be designed using either Section 1911.7.4 or any other shear transfer design methods that result in prediction of strength in substantial agreement with results of comprehensive tests.

**1911.7.3.1** Provisions of Sections 1911.7.5 through 1911.7.10 shall apply for all calculations of shear transfer strength.

### 1911.7.4 Shear-friction design methods.

**1911.7.4.1** When shear-friction reinforcement is perpendicular to shear plane, shear strength  $V_n$  shall be computed by

$$V_n = A_{vf} f_y \mu \quad (11-26)$$

where  $\mu$  is coefficient of friction in accordance with Section 1911.7.4.3.

**1911.7.4.2** When shear-friction reinforcement is inclined to shear plane such that the shear force produces tension in shear-friction reinforcement, shear strength  $V_n$  shall be computed by

$$V_n = A_{vf} f_y (\mu \sin \alpha_1 + \cos \alpha_1) \quad (11-27)$$

where  $\alpha_1$  is angle between shear-friction reinforcement and shear plane.

**1911.7.4.3** Coefficient of friction  $\mu$  in Formula (11-26) and Formula (11-27) shall be

Concrete placed monolithically	1.4 $\lambda$
Concrete placed against hardened concrete with surface intentionally roughened as specified in Section 1911.7.9	1.0 $\lambda$
Concrete placed against hardened concrete not intentionally roughened	0.6 $\lambda$
Concrete anchored to as-rolled structural steel by headed studs or by reinforcing bars (see Section 1911.7.10)	0.7 $\lambda$

where  $\lambda = 1.0$  for normal-weight concrete, 0.85 for sand-lightweight concrete and 0.75 for all-lightweight concrete. Linear interpolation may be applied when partial sand replacement is used.

**1911.7.5** Shear strength  $V_n$  shall not be taken greater than  $0.2f'_cA_c$  or  $800A_c$  in pounds ( $5.5A_c$  in newtons), where  $A_c$  is area of concrete section resisting shear transfer.

**1911.7.6** Design yield strength of shear-friction reinforcement shall not exceed 60,000 psi (413.7 MPa).

**1911.7.7** Net tension across shear plane shall be resisted by additional reinforcement. Permanent net compression across shear plane may be taken as additive to the force in the shear-friction reinforcement  $A_{vf}f_y$  when calculating required  $A_{vf}$ .

**1911.7.8** Shear-friction reinforcement shall be appropriately placed along the shear plane and shall be anchored to develop the specified yield strength on both sides by embedment, hooks or welding to special devices.

**1911.7.9** For the purpose of Section 1911.7, when concrete is placed against previously hardened concrete, the interface for shear transfer shall be clean and free of laitance. If  $\mu$  is assumed equal to  $1.0\lambda$ , interface shall be roughened to a full amplitude of approximately  $1/4$  inch (6.4 mm).

**1911.7.10** When shear is transferred between as-rolled steel and concrete using headed studs or welded reinforcing bars, steel shall be clean and free of paint.

### 1911.8 Special Provisions for Deep Flexural Members.

**1911.8.1** Provisions of this section shall apply for members with  $l_n/d$  less than 5 that are loaded on one face and supported on the opposite face so that the compression struts can develop between the loads and the supports. See also Section 1912.10.6.

**1911.8.2** The design of simple supported deep flexural members for shear shall be based on Formulas (11-1) and (11-2), where shear strength  $V_c$  shall be in accordance with Section 1911.8.6 or 1911.8.7, and shear strength  $V_s$  shall be in accordance with Section 1911.8.8.

**1911.8.3** The design of continuous deep flexural members for shear shall be based on Sections 1911.1 through 1911.5 with Section 1911.8.5 substituted for Section 1911.1.3, or on methods satisfying equilibrium and strength requirements. In either case, the design shall also satisfy Sections 1911.8.4, 1911.8.9 and 1911.8.10.

**1911.8.4** Shear strength  $V_n$  for deep flexural members shall not be taken greater than  $8\sqrt{f'_c}b_wd$  (For SI:  $0.66\sqrt{f'_c}b_wd$ ) when  $l_n/d$  is less than 2. When  $l_n/d$  is between 2 and 5,

$$V_n = \frac{2}{3} \left( 10 + \frac{l_n}{d} \right) \sqrt{f'_c} b_w d \quad (11-28)$$

For SI: 
$$V_n = 0.055 \left( 10 + \frac{l_n}{d} \right) \sqrt{f'_c} b_w d$$

**1911.8.5** Critical section for shear measured from face of support shall be taken at a distance  $0.15l_n$  for uniformly loaded beams and  $0.50a$  for beams with concentrated loads, but not greater than  $d$ .

**1911.8.6** Unless a more detailed calculation is made in accordance with Section 1911.8.7,

$$V_c = 2\sqrt{f'_c} b_w d \quad (11-29)$$

For SI: 
$$V_c = 0.166\sqrt{f'_c} b_w d$$

**1911.8.7** Shear strength  $V_c$  may be computed by

$$V_c = \left( 3.5 - 2.5 \frac{M_u}{V_u d} \right) \left( 1.9\sqrt{f'_c} + 2,500\rho_w \frac{V_u d}{M_u} \right) b_w d \quad (11-30)$$

For SI: 
$$V_c = \left( 3.5 - 2.5 \frac{M_u}{V_u d} \right) \left( 0.16\sqrt{f'_c} + 17.2\rho_w \frac{V_u d}{M_u} \right) b_w d$$

except that the term

$$\left( 3.5 - 2.5 \frac{M_u}{V_u d} \right)$$

shall not exceed 2.5, and  $V_c$  shall not be taken greater than  $6\sqrt{f'_c} b_w d$  (For SI:  $0.5\sqrt{f'_c} b_w d$ ).  $M_u$  is factored moment occurring simultaneously with  $V_u$  at the critical section defined in Section 1911.8.5.

**1911.8.8** Where factored shear force  $V_u$  exceeds shear strength  $\phi V_c$ , shear reinforcement shall be provided to satisfy Formulas (11-1) and (11-2), where shear strength  $V_s$  shall be computed by

$$V_s = \left[ \frac{A_v}{s} \left( \frac{1 + \frac{l_n}{d}}{12} \right) + \frac{A_{vh}}{s_2} \left( \frac{11 - \frac{l_n}{d}}{12} \right) \right] f_y d \quad (11-31)$$

where  $A_v$  is area of shear reinforcement perpendicular to flexural tension reinforcement within a distance  $s$ , and  $A_{vh}$  is area of shear reinforcement parallel to flexural reinforcement within a distance  $s_2$ .

**1911.8.9** Area of shear reinforcement  $A_v$  shall not be less than  $0.0015 b_w s$ , and  $s$  shall not exceed  $d/5$  or 18 inches (457 mm).

**1911.8.10** Area of horizontal shear reinforcement  $A_{vh}$  shall not be less than  $0.0025 b_w s_2$ , and  $s_2$  shall not exceed  $d/3$  or 18 inches (457 mm).

**1911.8.11** Shear reinforcement required at the critical section defined in Section 1911.8.5 shall be used throughout the span.

### 1911.9 Special Provisions for Brackets and Corbels.

**1911.9.1** The following provisions apply to brackets and corbels with a shear span-to-depth ratio  $a/d$  not greater than unity, and subject to a horizontal tensile force  $N_{uc}$  not larger than  $V_u$ . Distance  $d$  shall be measured at face of support.

**1911.9.2** Depth at outside edge of bearing area shall not be less than  $0.5d$ .

**1911.9.3** Section at face of support shall be designed to resist simultaneously a shear  $V_u$ , a moment  $[V_u a + N_{uc} (h - d)]$ , and a horizontal tensile force  $N_{uc}$ .

**1911.9.3.1** In all design calculations in accordance with Section 1911.9, strength-reduction factor  $\phi$  shall be taken equal to 0.85.

**1911.9.3.2** Design of shear-friction reinforcement  $A_{vf}$  to resist shear  $V_u$  shall be in accordance with Section 1911.7.

**1911.9.3.2.1** For normal-weight concrete, shear strength  $V_n$  shall not be taken greater than  $0.2f'_c b_w d$  nor  $800 b_w d$  in pounds ( $5.5 b_w d$  in newtons).

**1911.9.3.2.2** For all lightweight or sand-lightweight concrete, shear strength  $V_n$  shall not be taken greater than  $(0.2 - 0.07 a/d) f'_c b_w d$  or  $(800 - 280 a/d) b_w d$  in pounds  $[(5.5 - 1.9 a/d) b_w d$  in newtons].

**1911.9.3.3** Reinforcement  $A_f$  to resist moment  $[V_u a + N_{uc} (h - d)]$  shall be computed in accordance with Sections 1910.2 and 1910.3.

**1911.9.3.4** Reinforcement  $A_n$  to resist tensile force  $N_{uc}$  shall be determined from  $N_{uc} \leq \phi A_n f_y$ . Tensile force  $N_{uc}$  shall not be taken less than  $0.2 V_u$  unless special provisions are made to avoid tensile forces. Tensile force  $N_{uc}$  shall be regarded as a live load even when tension results from creep, shrinkage or temperature change.

**1911.9.3.5** Area of primary tension reinforcement  $A_s$  shall be made equal to the greater of ( $A_f + A_n$ ) or ( $2A_v/3 + A_n$ ).

**1911.9.4** Closed stirrups or ties parallel to  $A_s$ , with a total area  $A_n$  not less than  $0.5(A_s - A_n)$ , shall be uniformly distributed within two thirds of the effective depth adjacent to  $A_s$ .

**1911.9.5** Ratio  $\rho = A_s/bd$  shall not be less than  $0.04(f'_c/f_y)$ .

**1911.9.6** At front face of bracket or corbel, primary tension reinforcement  $A_s$  shall be anchored by one of the following: (1) by a structural weld to a transverse bar of at least equal size; weld to be designed to develop specified yield strength  $f_y$  of  $A_s$  bars; (2) by bending primary tension bars  $A_s$  back to form a horizontal loop; or (3) by some other means of positive anchorage.

**1911.9.7** Bearing area of load on bracket or corbel shall not project beyond straight portion of primary tension bar  $A_s$ , or project beyond interior face of transverse anchor bar (if one is provided).

**1911.10 Special Provisions for Walls.**

**1911.10.1** Design for shear forces perpendicular to face of wall shall be in accordance with provisions for slabs in Section 1911.12. Design for horizontal shear forces in plane of wall shall be in accordance with Section 1911.10.2 through 1911.10.8.

**1911.10.2** Design of horizontal section for shear in plane of wall shall be based on Formulas (11-1) and (11-2), where shear strength  $V_c$  shall be in accordance with Section 1911.10.5 or 1911.10.6 and shear strength  $V_s$  shall be in accordance with Section 1911.10.9.

**1911.10.3** Shear strength  $V_n$  at any horizontal section for shear in plane of wall shall not be taken greater than  $10\sqrt{f'_c}hd$  (For SI:  $0.83\sqrt{f'_c}hd$ ).

**1911.10.4** For design for horizontal shear forces in plane of wall,  $d$  shall be taken equal to  $0.8l_w$ . A larger value of  $d$ , equal to the distance from extreme compression fiber to center of force of all reinforcement in tension may be used when determined by a strain compatibility analysis.

**1911.10.5** Unless a more detailed calculation is made in accordance with Section 1911.10.6, shear strength  $V_c$  shall not be taken greater than  $2\sqrt{f'_c}hd$  (For SI:  $0.166\sqrt{f'_c}hd$ ) for walls subject to  $N_u$  in compression, or  $V_c$  shall not be taken greater than the value given in Section 1911.3.2.3 for walls subject to  $N_u$  in tension.

**1911.10.6** Shear strength  $V_c$  may be computed by Formulas (11-32) and (11-33), where  $V_c$  shall be the lesser of Formula (11-32) or (11-33).

$$V_c = 3.3\sqrt{f'_c}hd + \frac{N_u d}{4l_w} \quad (11-32)$$

For SI:

$$V_c = 0.27\sqrt{f'_c}hd + \frac{N_u d}{4l_w}$$

or

$$V_c = \left[ 0.6\sqrt{f'_c} + \frac{l_w \left( 1.25\sqrt{f'_c} + 0.2 \frac{N_u}{l_w h} \right)}{\frac{M_u}{V_u} - \frac{l_w}{2}} \right] hd \quad (11-33)$$

For SI:

$$V_c = \left[ 0.05\sqrt{f'_c} + \frac{l_w \left( 0.10\sqrt{f'_c} + 0.2 \frac{N_u}{l_w h} \right)}{\frac{M_u}{V_u} - \frac{l_w}{2}} \right] hd$$

where  $N_u$  is negative for tension. When  $(M_u/V_u - l_w/2)$  is negative, Formula (11-33) shall not apply.

**1911.10.7** Sections located closer to wall base than a distance  $l_w/2$  or one half the wall height, whichever is less, may be designed for the same  $V_c$  as that computed at a distance  $l_w/2$  or one half the height.

**1911.10.8** When factored shear force  $V_u$  is less than  $\phi V_c/2$ , reinforcement shall be provided in accordance with Section 1911.10.9 or in accordance with Section 1914. When  $V_u$  exceeds  $\phi V_c/2$ , wall reinforcement for resisting shear shall be provided in accordance with Section 1911.10.9.

**1911.10.9 Design of shear reinforcement for walls.**

**1911.10.9.1** Where factored shear force  $V_u$  exceeds shear strength  $\phi V_c$ , horizontal shear reinforcement shall be provided to satisfy Formulas (11-1) and (11-2), where shear strength  $V_s$  shall be computed by

$$V_s = \frac{A_v f_y d}{s_2} \quad (11-34)$$

where  $A_v$  is area of horizontal shear reinforcement within a distance  $s_2$  and distance  $d$  is in accordance with Section 1911.10.4. Vertical shear reinforcement shall be provided in accordance with Section 1911.10.9.4.

**1911.10.9.2** Ratio  $\rho_h$  of horizontal shear reinforcement area to gross concrete area of vertical section shall not be less than 0.0025.

**1911.10.9.3** Spacing of horizontal shear reinforcement  $s_2$  shall not exceed  $l_w/5$ ,  $3h$  or 18 inches (457 mm).

**1911.10.9.4** Ratio  $\rho_n$  of vertical shear reinforcement area to gross concrete area of horizontal section shall not be less than

$$\rho_n = 0.0025 + 0.5 \left( 2.5 - \frac{h_w}{l_w} \right) (\rho_h - 0.0025) \quad (11-35)$$

or 0.0025, but need not be greater than the required horizontal shear reinforcement.

**1911.10.9.5** Spacing of vertical shear reinforcement  $s_1$  shall not exceed  $l_w/3$ ,  $3h$  or 18 inches (457 mm).

**1911.11 Transfer of Moments to Columns.**

**1911.11.1** When gravity load, wind, earthquake or other lateral forces cause transfer of moment at connections of framing elements to columns, the shear resulting from moment transfer shall be considered in the design of lateral reinforcement in the columns.

**1911.11.2** Except for connections not part of a primary seismic load-resisting system that are restrained on four sides by beams or slabs of approximately equal depth, connections shall have lateral reinforcement not less than that required by Formula (11-14) within the column for a depth not less than that of the deepest connection of framing elements to the columns. See also Section 1907.9.

**1911.12 Special Provisions for Slabs and Footings.**

**1911.12.1** The shear strength of slabs and footings in the vicinity of columns, concentrated loads or reactions is governed by the more severe of two conditions:

**1911.12.1.1** Beam action where each critical section to be investigated extends in a plane across the entire width. For beam action the slab or footing shall be designed in accordance with Sections 1911.1 through 1911.5.

**1911.12.1.2** Two-way action where each of the critical sections to be investigated shall be located so that its perimeter,  $b_o$ , is a minimum, but need not approach closer than  $d/2$  to:

1. Edges or corners of columns, concentrated loads or reaction areas, or
2. Changes in slab thickness such as edges of capitals or drop panels, or
3. *Outer limits of, or changes in, the slab or footing shear reinforcement.*

For two-way action, the slab of footing shall be designed in accordance with Sections 1911.12.2 through 1911.12.6.

**1911.12.1.3** For square or rectangular columns, concentrated loads or reactions areas, the critical sections may have four straight sides.

**1911.12.2** The design of a slab or footing for two-way action is based on Formulas (11-1) and (11-2).  $V_c$  shall be computed in accordance with Section 1911.12.2.1, 1911.12.2.2 or 1911.12.3.1.  $V_s$  shall be computed in accordance with Section 1911.12.3. For slabs with shear heads,  $V_n$  shall be in accordance with Section 1911.12.4. When moment is transferred between a slab and a column, Section 1911.12.6 shall apply.

**1911.12.2.1** For nonprestressed slabs and footings,  $V_c$  shall be the smallest of:

$$1. \quad V_c = \left( 2 + \frac{4}{\beta_c} \right) \sqrt{f'_c} b_o d \quad (11-36)$$

$$\text{For SI:} \quad V_c = 0.083 \left( 2 + \frac{4}{\beta_c} \right) \sqrt{f'_c} b_o d$$

where  $\beta_c$  is the ratio of long side to short side of the column, concentrated load or reaction area

$$2. \quad V_c = \left( \frac{\alpha_s d}{b_o} + 2 \right) \sqrt{f'_c} b_o d \quad (11-37)$$

$$\text{For SI:} \quad V_c = 0.083 \left( \frac{\alpha_s d}{b_o} + 2 \right) \sqrt{f'_c} b_o d$$

where  $\alpha_s$  is 40 for interior columns, 30 for edge columns and 20 for corner columns, and

$$3. \quad V_c = 4 \sqrt{f'_c} b_o d \quad (11-38)$$

$$\text{For SI:} \quad V_c = 0.33 \sqrt{f'_c} b_o d$$

**1911.12.2.2** At columns of two-way prestressed slabs and footings that meet the requirements of Section 1918.9.3:

$$V_c = (\beta_p \sqrt{f'_c} + 0.3f_{pc}) b_o d + V_p \quad (11-39)$$

$$\text{For SI:} \quad V_c = (0.083 \beta_p \sqrt{f'_c} + 0.3f_{pc}) b_o d + V_p$$

where  $\beta_p$  is the smaller of 3.5 or  $(\alpha_s d / b_o + 1.5)$ ,  $\alpha_s$  is 40 for interior columns, 30 for edge columns and 20 for corner columns,  $b_o$  is perimeter of critical section defined in Section 1911.12.1.2,  $f_{pc}$  is the average value of  $f_{pc}$  for the two directions, and  $V_p$  is the vertical component of all effective prestress forces crossing the critical section.  $V_c$  may be computed by Formula (11-39) if the following are satisfied; otherwise, Section 1911.12.2.1 shall apply:

1. No portion of the column cross section shall be closer to the discontinuous edge than four times the slab thickness, and
2.  $f'_c$  in Formula (11-39) shall not be taken greater than 5,000 psi (34.47 MPa), and
3.  $f_{pc}$  in each direction shall not be less than 125 psi (0.86 MPa), or be taken greater than 500 psi (3.45 MPa).

**1911.12.3** Shear reinforcement consisting of bars or wires is permitted in slabs and footings in accordance with the following:

**1911.12.3.1**  $V_n$  shall be computed by Formula (11-2), where  $V_c$  shall not be taken greater than  $2 \sqrt{f'_c} b_o d$  (For SI:  $0.166 \sqrt{f'_c} b_o d$ ), and the required area of shear reinforcement  $A_v$  and  $V_s$  shall be calculated in accordance with Section 1911.5 and anchored in accordance with Section 1912.13.

**1911.12.3.2**  $V_n$  shall not be taken greater than  $6\sqrt{f'_c}b_o d$  (For SI:  $0.50\sqrt{f'_c}b_o d$ ).

**1911.12.4** Shear reinforcement consisting of steel I- or channel-shaped sections (shearheads) is permitted in slabs. The provisions of Sections 1911.12.4.1 through 1911.12.4.9 shall apply where shear due to gravity load is transferred at interior column supports. Where moment is transferred to columns, Section 1911.12.6.3 shall apply.

**1911.12.4.1** Each shearhead shall consist of steel shapes fabricated by welding with a full penetration weld into identical arms at right angles. Shearhead arms shall not be interrupted within the column section.

**1911.12.4.2** A shearhead shall not be deeper than 70 times the web thickness of the steel shape.

**1911.12.4.3** The ends of each shearhead arm may be cut at angles not less than 30 degrees with the horizontal, provided the plastic moment strength of the remaining tapered section is adequate to resist the shear force attributed to the arm of the shearhead.

**1911.12.4.4** All compression flanges of steel shapes shall be located within  $0.3d$  of compression surface of slab.

**1911.12.4.5** The ratio  $\alpha_v$  between the stiffness of each shearhead arm and that of the surrounding composite cracked slab section of width  $(c_2 + d)$  shall not be less than 0.15.

**1911.12.4.6** The plastic moment strength  $M_p$  required for each arm of the shearhead shall be computed by

$$\phi M_p = \frac{V_u}{2\eta} \left[ h_v + \alpha_v \left( l_v - \frac{c_1}{2} \right) \right] \quad (11-40)$$

where  $\phi$  is the strength-reduction factor for flexure,  $\eta$  is the number of arms, and  $l_v$  is the minimum length of each shearhead arm required to comply with requirements of Section 1911.12.4.7 and 1911.12.4.8.

**1911.12.4.7** The critical slab section for shear shall be perpendicular to the plane of the slab and shall cross each shearhead arm at three fourths the distance  $[l_v - (c_1/2)]$  from the column face to the end of the shearhead arm. The critical section shall be located so that its perimeter  $b_o$  is a minimum, but need not be closer than the perimeter defined in Section 1911.12.1.2, Item 1.

**1911.12.4.8**  $V_n$  shall not be taken greater than  $4\sqrt{f'_c}b_o d$  (For SI:  $0.33\sqrt{f'_c}b_o d$ ), on the critical section defined in Section 1911.12.4.7. When shearhead reinforcement is provided,  $V_n$  shall not be taken greater than  $7\sqrt{f'_c}b_o d$  (For SI:  $0.58\sqrt{f'_c}b_o d$ ), on the critical section defined in Section 1911.12.1.2, Item 1.

**1911.12.4.9** A shearhead may be assumed to contribute a moment resistance  $M_v$  to each slab column strip computed by

$$M_v = \frac{\phi \alpha_v V_u}{2\eta} \left( l_v - \frac{c_1}{2} \right) \quad (11-41)$$

where  $\phi$  is the strength-reduction factor for flexure,  $\eta$  is the number of arms, and  $l_v$  is the length of each shearhead arm actually provided. However,  $M_v$  shall not be taken larger than the smaller of:

1. Thirty percent of the total factored moment required for each slab column strip,
2. The change in column strip moment over the length  $l_v$ ,
3. The value of  $M_p$  computed by Formula (11-40).

**1911.12.4.10** When unbalanced moments are considered, the shearhead must have adequate anchorage to transmit  $M_p$  to column.

**1911.12.5 Opening in slabs.** When openings in slabs are located at a distance less than 10 times the slab thickness from a concentrated load or reaction area, or when openings in flat slabs are located within column strips as defined in Section 1913, the critical slab sections for shear defined in Section 1911.12.1.2 and Section 1911.12.4.7 shall be modified as follows:

**1911.12.5.1** For slabs without shearheads, that part of the perimeter of the critical section that is enclosed by straight lines projecting from the centroid of the column, concentrated load or reaction area and tangent to the boundaries of the openings shall be considered ineffective.

**1911.12.5.2** For slabs with shearheads, the ineffective portion of the perimeter shall be one half of that defined in Section 1911.12.5.1.

**1911.12.6 Transfer of moment in slab-column connections.**

**1911.12.6.1** When gravity load, wind, earthquake or other lateral forces cause transfer of unbalanced moment,  $M_u$ , between a slab and a column, a fraction  $\gamma_f M_u$  of the unbalanced moment shall be transferred by flexure in accordance with Section 1913.3. The remainder of the unbalanced moment given by  $\gamma_v M_u$  shall be considered to be transferred by eccentricity of shear about the centroid of the critical section defined in Section 1911.12.1.2 where:

$$\gamma_v = 1 - \frac{1}{1 + \frac{2}{3} \sqrt{b_1/b_2}} \quad (11-42)$$

**1911.12.6.2** The shear stress resulting from moment transfer by eccentricity of shear shall be assumed to vary linearly about the centroid of the critical sections defined in Section 1911.12.1.2. The maximum shear stress due to the factored shear force and moment shall not exceed  $\phi v_n$ :

For members without shear reinforcement:

$$\phi v_n = \phi V_c / (b_o d) \quad (11-43)$$

where  $V_c$  is as defined in Section 1911.12.2.1 and 1911.12.2.2.

For members with shear reinforcement other than shearheads:

$$\phi v_n = \phi (V_c + V_s) / (b_o d) \quad (11-44)$$

where  $V_c$  and  $V_s$  are defined in Section 1911.12.3. If shear reinforcement is provided, the design shall take into account the variation of shear stress around the column.

**1911.12.6.3** When shear reinforcement consisting of steel I- or channel-shaped sections (shearheads) is provided, the sum of the shear stresses due to vertical load acting on the critical section defined by Section 1911.12.4.7 and the shear stresses resulting from moment transferred by eccentricity of shear about the centroid of the critical section defined in Section 1911.12.1.2 shall not exceed  $\phi 4 \sqrt{f'_c}$  (For SI:  $\phi 0.33 \sqrt{f'_c}$ ).

## SECTION 1912 — DEVELOPMENT AND SPLICES OF REINFORCEMENT

### 1912.0 Notations.

- $A_b$  = area of an individual bar, square inches ( $\text{mm}^2$ ).
- $A_s$  = area of nonprestressed tension reinforcement, square inches ( $\text{mm}^2$ ).
- $A_{tr}$  = total cross-sectional area of transverse reinforcement (stirrup or tie) within a spacing  $s$  and perpendicular to plane of bars being spliced or developed, square inches ( $\text{mm}^2$ ).
- $A_v$  = area of shear reinforcement within a distance  $s$ , square inches ( $\text{mm}^2$ ).
- $A_w$  = area of an individual wire to be developed or spliced, square inches ( $\text{mm}^2$ ).
- $a$  = depth of equivalent rectangular stress block as defined in Section 1910.2.7.1.
- $b_w$  = web width, or diameter of circular section, inches (mm).

- $d$  = distance from extreme compression fiber to centroid of tension reinforcement, inches (mm).  
 $d_b$  = nominal diameter of bar, wire or prestressing strand, inches (mm).  
 $f'_c$  = specified compressive strength of concrete, pounds per square inch (MPa).  
 $\sqrt{f'_c}$  = square root of specified compressive strength of concrete, pounds per square inch (MPa).  
 $f_{ct}$  = average splitting tensile strength of lightweight aggregate concrete, pounds per square inch (MPa).  
 $f_{ps}$  = stress in prestressed reinforcement at nominal strength, kips per square inch (MPa).  
 $f_{se}$  = effective stress in prestressed reinforcement (after allowance for all prestress losses), kips per square inch (MPa).  
 $f_y$  = specified yield strength of nonprestressed reinforcement, pounds per square inch (MPa).  
 $h$  = overall thickness of member, inches (mm).  
 $l_a$  = additional embedment length at support or at point of inflection, inches (mm).  
 $l_d$  = development length, inches (mm).  
 $= l_{db} \times$  applicable modification factors.  
 $l_{db}$  = basic development length, inches (mm).  
 $l_{dh}$  = development length of standard hook in tension, measured from critical section to outside end of hook [straight embedment length between critical section and start of hook (point of tangency) plus radius of bend and one bar diameter], inches (mm).  
 $= l_{hb} \times$  applicable modification factors.  
 $l_{hb}$  = basic development length of standard hook in tension, inches (mm).  
 $M_n$  = nominal moment strength at section, inch-pounds (N·m).  
 $= A_s f_y (d - a/2)$ .  
 $N$  = number of bars in a layer being spliced or developed at a critical section.  
 $s$  = spacing of stirrups or ties, inches (mm).  
 $s_w$  = spacing of wire to be developed or spliced, inches (mm).  
 $V_u$  = factored shear force at section.  
 $\beta_b$  = ratio of area of reinforcement cut off to total area of tension reinforcement at section.

### 1912.1 Development of Reinforcement—General.

**1912.1.1** Calculated tension or compression in reinforcement at each section of reinforced concrete members shall be developed on each side of that section by embedment length, hook or mechanical device, or a combination thereof. Hooks may be used in developing bars in tension only.

**1912.1.2** The values of  $\sqrt{f'_c}$  used in Section 1912 shall not exceed 100 psi (0.69 MPa).

### 1912.2 Development of Deformed Bars and Deformed Wire in Tension.

**1912.2.1** Development length,  $l_d$ , in inches (mm), for deformed bars and deformed wire in tension shall be computed as the product of the basic development length  $l_{db}$  of Section 1912.2.2 and the applicable modification factors of Sections 1912.2.3 through 1912.2.5, but  $l_d$  shall not be less than 12 inches (305 mm).

**1912.2.2** Basic development length  $l_{db}$  shall be:

No. 11 bar and smaller and deformed wire  $0.04A_b f_y / \sqrt{f'_c}$  \*

\*The constant carries the unit of one/inch (one/mm).

For SI:

$$\left( \frac{0.019A_b f_y}{\sqrt{f'_c}} \right)$$

No. 14 bar	$0.085f_y/\sqrt{f'_c}^{**}$
For SI:	$\left(\frac{26f_y}{\sqrt{f'_c}}\right)$
No. 18 bar	$0.125f_y/\sqrt{f'_c}^{**}$
For SI:	$\left(\frac{38f_y}{\sqrt{f'_c}}\right)$

\*\*The constant carries the unit of inch (mm).

**1912.2.3** To account for bar spacing, amount of cover and enclosing transverse reinforcement, the basic development length shall be multiplied by a factor from Section 1912.2.3.1, 1912.2.3.2 or 1912.2.3.3, which may be modified by Sections 1912.2.3.4 and 1912.2.3.5, but shall not be less than provided by Section 1912.2.3.6.

**1912.2.3.1** For bars satisfying any one of the following conditions . . . . . 1.0.

1. Bars in beams or columns with (1) minimum cover not less than specified in Section 1907.7.1, (2) transverse reinforcement satisfying tie requirements of Section 1907.10.5 or minimum stirrup requirements of Sections 1911.5.4 and 1911.5.5.3 along the development length, and (3) clear spacing of not less than  $3d_b$ .
2. Bars in beams or columns with (1) minimum cover not less than specified in Section 1907.7.1, and (2) enclosed within transverse reinforcement  $A_{tr}$ , along the development length satisfying Formula (12-1).

$$A_{tr} \geq \frac{d_b s N}{40} \tag{12-1}$$

where  $d_b$  is the diameter of the bar being developed.

3. Bars in the inner layer of slab or wall reinforcement and with clear spacing of not less than  $3d_b$ .
4. Any bars with cover of not less than  $2d_b$  and with clear spacing of not less than  $3d_b$ .

**1912.2.3.2** For bars with cover of  $d_b$  or less or with clear spacing of  $2d_b$  or less . . . . . 2.0.

**1912.2.3.3** For bars not included in Section 1912.2.3.1 or 1912.2.3.2 . . . . . 1.4.

**1912.2.3.4** For No. 11 bars and smaller with clear spacing not less than  $5d_b$  and with cover from face of member to edge bar, measured in the plane of the bars, not less than  $2.5d_b$ , the factors in Sections 1912.2.3.1 through 1912.2.3.3 may be multiplied by 0.8.

**1912.2.3.5** For reinforcement enclosed within spiral reinforcement not less than 1/4-inch (6.4 mm) diameter and not more than 4 inches (102 mm) pitch, within No. 4 or larger circular ties spaced at not more than 4 inches (102 mm) on center, or within No. 4 or larger ties or stirrups spaced not more than 4 inches (102 mm) on center and arranged such that alternate bars shall have support provided by the corner of a tie or hoop with an included angle of not more than 135 degrees, the factors in Sections 1912.2.3.1 through 1912.2.3.3, may be multiplied by 0.75.

**1912.2.3.6** The basic development length multiplied by the applicable factor of Sections 1912.2.3.1 through 1912.2.3.3, with modifiers of Sections 1912.2.3.4 and 1912.2.3.5, shall not be taken less than

	$0.03d_b f_y/\sqrt{f'_c}$
For SI:	$0.36d_b f_y/\sqrt{f'_c}$

**1912.2.4** Basic development length  $l_{db}$  as modified by Section 1912.2.3 shall also be multiplied by applicable factor or factors for:

**1912.2.4.1 Top reinforcement.** Horizontal reinforcement so placed that more than 12 inches (305 mm) of fresh concrete is cast in the member below the development length or splice ..... 1.3

**1912.2.4.2 Lightweight aggregate concrete** ..... 1.3

Or when  $f_{ct}$  is specified .....  $6.7 \sqrt{f'_c} / f_{ct}$  (For **SI**:  $0.56 \sqrt{f'_c} / f_{ct}$ ) but not less than 1.0.

**1912.2.4.3 Epoxy-coated reinforcement.** Bars with cover less than  $3d_b$  or clear spacing between bars less than  $6d_b$  ..... 1.5  
All other conditions ..... 1.2

The product of the factor for top reinforcement of Section 1912.2.4.1 and the factor for epoxy-coated reinforcement of this section need not be taken greater than 1.7.

**1912.2.5 Excess reinforcement.** Development length may be reduced where reinforcement in a flexural member is in excess of that required by analysis except where anchorage or development for  $f_y$  is specifically required or the reinforcement is designed under provisions of Section 1921.2.1.4 .....  $[(A_s \text{ required}) / (A_s \text{ provided})]$

**1912.3 Development of Deformed Bars in Compression.**

**1912.3.1** Development length  $l_d$ , in inches, for deformed bars in compression shall be computed as the product of the basic development length  $l_{db}$  and applicable modification factors as defined in this section, but  $l_d$  shall not be less than 8 inches (203 mm).

**1912.3.2** Basic development length  $l_{db}$  shall be .....  $0.02d_b f_y / \sqrt{f'_c}$  (For **SI**:  $0.24d_b f_y / \sqrt{f'_c}$ ) but not less than .....  $0.0003d_b f_y$  (For **SI**:  $0.044 d_b f_y$ )

**1912.3.3** Basic development length  $l_{db}$  may be multiplied by applicable factors for:

**1912.3.3.1 Excess reinforcement.** Reinforcement in excess of that required by analysis .....  $(A_s \text{ required}) / (A_s \text{ provided})$

**1912.3.3.2 Spirals and ties.** Reinforcement enclosed within spiral reinforcement not less than  $1/4$ -inch (6.4 mm) diameter and not more than 4-inch (102 mm) pitch or within No. 4 ties in conformance with Section 1907.10.5 and spaced not more than 4 inches (102 mm) on center ..... 0.75

**1912.4 Development of Bundled Bars.**

**1912.4.1** Development length of individual bars within a bundle, in tension or compression, shall be that for the individual bar, increased 20 percent for 3-bar bundle, and 33 percent for 4-bar bundle.

**1912.4.2** For determining the appropriate factors in Sections 1912.2.3 and 1912.2.4.3, a unit of bundled bars shall be treated as a single bar of a diameter derived from the equivalent total area.

**1912.5 Development of Standard Hooks in Tension.**

**1912.5.1** Development length  $l_{dh}$  in inches (mm) for deformed bars in tension terminating in a standard hook shall be computed as the product of the basic development length  $l_{hb}$  of Section 1912.5.2 and the applicable modification factor or factors of Section 1912.5.3, but  $l_{dh}$  shall not be less than  $8d_b$  or less than 6 inches (152 mm).

**1912.5.2** Basic development length  $l_{hb}$  for a hooked bar with  $f_y$  equal to 60,000 psi (413.7 MPa) shall be .....  $1,200 d_b / \sqrt{f'_c}$  (For **SI**:  $99.7 d_b / \sqrt{f'_c}$ )

**1912.5.3** Basic development length  $l_{hb}$  shall be multiplied by applicable factor or factors for:

**1912.5.3.1 Bar yield strength.** Bars with  $f_y$  other than 60,000 psi (413.7 MPa) .....  $f_y/60,000$  (For SI:  $f_y/413.7$ )

**1912.5.3.2 Concrete cover.** For No. 11 bar and smaller, side cover (normal to plane of hook) but not less than  $2\frac{1}{2}$  inches (64 mm); for 90-degree hook, cover on bar extension beyond hook not less than 2 inches (51 mm) for No. 6 bar and larger and  $1\frac{1}{2}$  inches (38 mm) cover for No. 5 bar and smaller ..... 0.7

**1912.5.3.3 Ties or stirrups.** For No. 11 bar and smaller, hook enclosed vertically or horizontally within ties or stirrup ties spaced along the full development length  $l_{dh}$  not greater than  $3d_b$ , where  $d_b$  is diameter of hooked bar ..... 0.8

**1912.5.3.4 Excessive reinforcement.** Where anchorage or development for  $f_y$  is not specifically required, reinforcement in excess of that required by analysis .....  $(A_s \text{ required})/(A_s \text{ provided})$

**1912.5.3.5 Lightweight aggregate concrete** ..... 1.3

**1912.5.3.6 Epoxy-coated reinforcement.** Hooked bars with epoxy coating ..... 1.2

**1912.5.4** For bars being developed by a standard hook at discontinuous ends of members with side cover and top (or bottom) cover over hook less than  $2\frac{1}{2}$  inches (64 mm), hooked bar shall be enclosed within ties or stirrups spaced along the full development length  $l_{dh}$  not greater than  $3d_b$ , where  $d_b$  is diameter of hooked bar. For this case, factor of Section 1912.5.3.3 shall not apply.

**1912.5.5** Hooks shall not be considered effective in developing bars in compression.

#### 1912.6 Mechanical Anchorage.

**1912.6.1** Any mechanical device capable of developing the strength of reinforcement without damage to concrete may be used as anchorage.

**1912.6.2** Test results showing adequacy of such mechanical devices shall be presented to the building official.

**1912.6.3** Development of reinforcement may consist of a combination of mechanical anchorage plus additional embedment length of reinforcement between the point of maximum bar stress and the mechanical anchorage.

#### 1912.7 Development of Welded Deformed Wire Fabric in Tension.

**1912.7.1** Development length  $l_d$ , in inches (mm), of welded deformed wire fabric measured from point of critical section to end of wire shall be computed as the product of either of the basic development lengths noted in this section and applicable modification factor or factors of Sections 1912.2.3 through 1912.2.5, but  $l_d$  shall not be less than 8 inches (203 mm) except in computation of lap splices by Section 1912.18 and development of web reinforcement by Section 1912.13.

**1912.7.2** Basic development length  $l_{db}$  of welded deformed wire fabric, with at least one cross wire within the development length not less than 2 inches (51 mm) from point of critical section, shall be

$$\frac{0.03d_b(f_y - 20,000)}{\sqrt{f'_c} *}$$

For SI:

$$\frac{0.36d_b(f_y - 138)}{\sqrt{f'_c}}$$

\*The 20,000 has units of psi (the 138 has units of MPa).

but not less than

$$0.20 \frac{A_w}{s_w} \frac{f_y}{\sqrt{f'_c}}$$

For SI: 
$$2.4 \frac{A_w}{s_w} \frac{f_y}{\sqrt{f'_c}}$$

**1912.7.3** Basic development length  $l_{db}$  of welded deformed wire fabric, with no cross wires within the development length, shall be determined as for deformed wire.

**1912.8 Development of Welded Smooth Wire Fabric in Tension.** Yield strength of welded smooth wire fabric shall be considered developed by embedment of two cross wires with the closer cross wire not less than 2 inches (51 mm) from point of critical section. However, basic development length  $l_{db}$  from point of critical section to outermost cross wire shall not be less than

$$0.27 \frac{A_w}{s_w} \frac{f_y}{\sqrt{f'_c}}$$

For SI: 
$$3.3 \frac{A_w}{s_w} \frac{f_y}{\sqrt{f'_c}}$$

the basic development length  $l_{db}$  shall be modified by  $(A_s \text{ required})/(A_s \text{ provided})$  for reinforcement in excess of that required by analysis and by factor of Section 1912.2.4.2 for lightweight aggregate concrete, but  $l_d$  shall not be less than 6 inches (152 mm) except in computation of lap splices by Section 1912.19.

**1912.9 Development of Prestressing Strand.**

**1912.9.1** Three- or seven-wire pretensioning strand shall be bonded beyond the critical section for a development length, in inches (mm), not less than

$$\left( f_{ps} - \frac{2}{3} f_{se} \right) d_b \dagger$$

For SI: 
$$0.145 \left( f_{ps} - \frac{2}{3} f_{se} \right) d_b$$

†Expression in parentheses used as a constant without units.

where  $d_b$  is strand diameter in inches (mm), and  $f_{ps}$  and  $f_{se}$  are expressed in kips per square inch (MPa).

**1912.9.2** Investigation may be limited to cross sections nearest each end of the member that are required to develop full design strength under specified factored loads.

**1912.9.3** Where bonding of a strand does not extend to end of member, and design includes tension at service load in precompressed tensile zone as permitted by Section 1918.4.2, development length specified above shall be doubled.

**1912.10 Development of Flexural Reinforcement—General.**

**1912.10.1** Tension reinforcement may be developed by bending across the web to be anchored or made continuous with reinforcement on the opposite face of member.

**1912.10.2** Critical sections for development of reinforcement in flexural members are at points of maximum stress and at points within the span where adjacent reinforcement terminates or is bent. Provisions of Section 1912.11.3 must be satisfied.

**1912.10.3** Reinforcement shall extend beyond the point at which it is no longer required to resist flexure for a distance equal to the effective depth of member or  $12d_b$ , whichever is greater, except at supports of simple spans and at free end of cantilevers.

**1912.10.4** Continuing reinforcement shall have an embedment length not less than the development length  $l_d$  beyond the point where bent or terminated tension reinforcement is no longer required to resist flexure.

**1912.10.5** Flexural reinforcement shall not be terminated in a tension zone unless one of the following conditions is satisfied:

**1912.10.5.1** Shear at the cutoff point does not exceed two thirds that permitted, including shear strength of shear reinforcement provided.

**1912.10.5.2** Stirrup area in excess of that required for shear and torsion is provided along each terminated bar or wire over a distance from the termination point equal to three fourths the effective depth of member. Excess stirrup area  $A_v$  shall not be less than  $60b_w s/f_y$  (For SI:  $0.41b_w s/f_y$ ). Spacing  $s$  shall not exceed  $d/8\beta_b$  where  $\beta_b$  is the ratio of area of reinforcement cut off to total area of tension reinforcement at the section.

**1912.10.5.3** For No. 11 bar and smaller, continuing reinforcement provides double the area required for flexure at the cutoff point and shear does not exceed three fourths that permitted.

- **1912.10.6** Adequate anchorage shall be provided for tension reinforcement in flexural members where reinforcement stress is not directly proportional to moment, such as sloped, stepped or tapered footings, brackets, deep flexural members, or members in which tension reinforcement is not parallel to compression face.

### 1912.11 Development of Positive Moment Reinforcement.

**1912.11.1** At least one third the positive moment reinforcement in simple members and one fourth the positive moment reinforcement in continuous members shall extend along the same face of member into the support. In beams, such reinforcement shall extend into the support at least 6 inches (152 mm).

**1912.11.2** When a flexural member is part of a primary lateral load-resisting system, positive moment reinforcement required to be extended into the support by Section 1912.11.1 shall be anchored to develop the specified yield strength  $f_y$  in tension at the face of support.

**1912.11.3** At simple supports and at points of inflection, positive moment tension reinforcement shall be limited to a diameter such that  $l_d$  computed for  $f_y$  by Section 1912.2 satisfies Formula (12-2), except Formula (12-2) need not be satisfied for reinforcement terminating beyond center line of simple supports by a standard hook or a mechanical anchorage at least equivalent to a standard hook.

$$l_d \leq \frac{M_n}{V_u} + l_a \quad (12-2)$$

#### WHERE:

$l_a$  = at a support shall be the embedment length beyond center of support.

$l_a$  = at a point of inflection shall be limited to the effective depth of member or  $12d_b$ , whichever is greater.

$M_n$  = nominal strength assuming all reinforcement at the section to be stressed to the specified yield strength  $f_y$ .

$V_u$  = factored shear force at the section.

Value of  $M_n/V_u$  may be increased 30 percent when the ends of reinforcement are confined by a compressive reaction.

### 1912.12 Development of Negative Moment Reinforcement.

**1912.12.1** Negative moment reinforcement in a continuous, restrained or cantilever member, or in any member of a rigid frame, shall be anchored in or through the supporting member by embedment length, hooks or mechanical anchorage.

**1912.12.2** Negative moment reinforcement shall have an embedment length into the span as required by Sections 1912.1 and 1912.10, Item 3.

**1912.12.3** At least one third the total tension reinforcement provided for negative moment at a support shall have an embedment length beyond the point of inflection not less than effective depth of member,  $12d_b$ , or  $1/16$  the clear span, whichever is greater.

**1912.13 Development of Web Reinforcement.**

**1912.13.1** Web reinforcement shall be carried as close to compression and tension surfaces of member as cover requirements and proximity of other reinforcement will permit.

**1912.13.2** Ends of single leg, simple U- or multiple U-stirrups shall be anchored by one of the following means:

**1912.13.2.1** For No. 5 bar and D31 wire, and smaller, and for Nos. 6, 7 and 8 bars with  $f_y$  of 40,000 psi (275.8 MPa) or less, a standard stirrup hood around longitudinal reinforcement.

**1912.13.2.2** For Nos. 6, 7 and 8 stirrups with  $f_y$  greater than 40,000 psi (275.8 MPa), a standard stirrup hook around a longitudinal bar plus an embedment between midheight of the member and the outside end of the hook equal to or greater than  $0.014 d_b f_y / \sqrt{f'_c}$  (For SI:  $0.169 d_b f_y / \sqrt{f'_c}$ ).

**1912.13.2.3** For each leg of welded smooth wire fabric forming simple U-stirrups, either:

1. Two longitudinal wires spaced at a 2-inch (51 mm) spacing along the member at the top of the U.
2. One longitudinal wire located not more than  $d/4$  from the compression face and a second wire closer to the compression face and spaced not less than 2 inches (51 mm) from the first wire. The second wire may be located on the stirrup leg beyond a bend, or on a bend with an inside diameter of bend not less than  $8d_b$ .
3. For each end of a single-leg stirrup of welded plain or deformed wire fabric, two longitudinal wires at a minimum spacing of 2 inches (51 mm) and with the inner wire at least the greater of  $d/4$  or 2 inches (51 mm) from middepth of member  $d/2$ . Outer longitudinal wire at tension face shall not be farther from the face than the portion of primary flexural reinforcement closest to the face.

**1912.13.3** Between anchored ends, each bend in the continuous portion of a simple U-stirrup or multiple U-stirrups shall enclose a longitudinal bar.

**1912.13.4** Longitudinal bars bent to act as shear reinforcement, if extended into a region of tension, shall be continuous with longitudinal reinforcement and, if extended into a region of compression, shall be anchored beyond middepth  $d/2$  as specified for development length in Section 1912.2 for that part of  $f_y$  required to satisfy Formula (11-19).

**1912.13.5** Pairs of U-stirrups or ties so placed as to form a closed unit shall be considered properly spliced when lengths of laps are  $1.3l_d$ . In members at least 18 inches (457 mm) deep, such splices with  $A_b f_y$  not more than 9,000 pounds (40 000 N) per leg may be considered adequate if stirrup legs extend the full available depth of member.

**1912.14 Splices of Reinforcement.**

**1912.14.1** Splices of reinforcement shall be made only as required or permitted on design drawings or in specifications, or as authorized by the *building official*.

**1912.14.2 Lap splices.**

**1912.14.2.1** Lap splices shall not be used for bars larger than No. 11, except as provided in Sections 1912.16.2 and 1915.8.2.3.

**1912.14.2.2** Lap splices of bars in a bundle shall be based on the lap splice length required for individual bars within the bundle, increased in accordance with Section 1912.4. Individual bar splices within a bundle shall not overlap. Entire bundles shall not be lap spliced.

**1912.14.2.3** Bars spliced by noncontact lap splices in flexural members shall not be spaced transversely farther apart than one fifth the required lap splice length, or 6 inches (152 mm).

**1912.14.3 Welded splices and mechanical connections.**

**1912.14.3.1** Welded splices and other mechanical connections may be used.

**1912.14.3.2** Except as provided in this code, all welding shall conform to U.B.C. Standard 19-2.

**1912.14.3.3** A full-welded splice shall have bars butted and welded to develop in tension at least 125 percent of specified yield strength  $f_y$  of the bar.

**1912.14.3.4** A full mechanical connection shall develop in tension or compression, as required, at least 125 percent of specified yield strength  $f_y$  of the bar.

**1912.14.3.5** Welded splices and mechanical connections not meeting requirements of Section 1912.14.3.3 or 1912.14.3.4, may be used in accordance with Section 1912.15.4.

**1912.14.3.6** *Welded splices and mechanical connections shall maintain the clearance and coverage requirements of Sections 1907.6 and 1907.7.*

**1912.15 Splices of Deformed Bars and Deformed Wire in Tension.**

**1912.15.1** Minimum length of lap for tension lap splices shall be as required for Class A or B splice, but not less than 12 inches (305 mm), where:

Class A splice .....	1.0 $l_d$
Class B splice .....	1.3 $l_d$

where  $l_d$  is the tensile development length for the specified yield strength  $f_y$  in accordance with Section 1912.2 without the modification factor of Section 1912.2.5.

**1912.15.2** Lap splices of deformed bars and deformed wire in tension shall be Class B splices except that Class A splices may be used when (1) the area of reinforcement provided is at least twice that required by analysis over the entire length of the splice, and (2) one half or less of the total reinforcement is spliced within the required lap length.

**1912.15.3** Welded splices or mechanical connections used where area of reinforcement provided is less than twice that required by analysis shall meet requirements of Section 1912.14.3.3 and 1912.14.3.4.

**1912.15.4** Welded splices or mechanical connections used where area of reinforcement provided is at least twice that required by analysis shall meet the following:

**1912.15.4.1** Splices shall be staggered at least 24 inches (610 mm) and in such manner as to develop at every section at least twice the calculated tensile force at that section but not less than 20,000 psi (137.9 MPa) for total area of reinforcement provided.

**1912.15.4.2** In computing tensile force developed at each section, spliced reinforcement may be rated at the specified splice strength. Unspliced reinforcement shall be rated at that fraction of  $f_y$  defined by the ratio of the shorter actual development length to  $l_d$  required to develop the specified yield strength  $f_y$ .

**1912.15.4.3** Splices in “tension tie members” shall be made with a full-welded splice or full mechanical connection in accordance with Section 1912.14.3.3 and 1912.14.3.4, and splices in adjacent bar shall be staggered at least 30 inches (762 mm).

**1912.15.4.4** *Mechanical connections need not be staggered as required by Section 1912.15.4.1 or 1912.15.4.3 above provided the clearance and coverage requirements of Sections 1907.6 and 1907.7 are maintained and, at 90 percent of the yield stress, the strain measured over the full length of the connector does not exceed 50 percent of the strain of an unspliced bar when the maximum computed design load stress does not exceed 50 percent of the yield stress.*

**1912.16 Splices of Deformed Bars in Compression.**

**1912.16.1** Compression lap splice length shall be  $0.0005 f_y d_b$  (For SI:  $0.073 f_y d_b$ ) for  $f_y$  of 60,000 psi (413.7 MPa) or less, or  $(0.0009 f_y - 24) d_b$  [For SI:  $(0.13 f_y - 24) d_b$ ] for  $f_y$  greater than 60,000 psi (413.7 MPa), but not less than 12 inches (305 mm). For  $f'_c$  less than 3,000 psi (20.68 MPa), length of lap shall be increased by one third.

**1912.16.2** When bars of different size are lap spliced in compression, splice length shall be the larger of: development length of larger bar, or splice length of smaller bar. Bar sizes Nos. 14 and 18 may be lap spliced to No. 11 and smaller bars.

**1912.16.3** Welded splices or mechanical connections used in compression shall meet requirements of Sections 1912.14.3.3 and 1912.14.3.4.

**1912.16.4 End-bearing splices.**

**1912.16.4.1** In bars required for compression only, compressive stress may be transmitted by bearing of square cut ends held in concentric contact by a suitable device.

**1912.16.4.2** Bar ends shall terminate in flat surfaces within  $1\frac{1}{2}$  degrees of a right angle to the axis of the bars and shall be fitted within 3 degrees of full bearing after assembly.

**1912.16.4.3** End-bearing splices shall be used only in members containing closed ties, closed stirrups or spirals.

**1912.17 Special Splice Requirements for Columns.**

**1912.17.1** Lap splices, butt welded splices, mechanical connections or end-bearing splices shall be used with the limitations of Sections 1912.17.2 through 1912.17.4. A splice shall satisfy requirements for all load combinations for the column.

**1912.17.2 Lap splices in columns.**

**1912.17.2.1** Where the bar stress due to factored loads is compressive, lap splices shall conform to Sections 1912.16.1 and 1912.16.2, and where applicable, to Sections 1912.17.2.4 and 1912.17.2.5.

**1912.17.2.2** Where the bar stress due to factored loads is tensile and does not exceed  $0.5f_y$  in tension, lap splices shall be Class B tension lap splices if more than one half of the bars are spliced at any section, or Class A tension lap splices if one half or fewer of the bars are spliced at any section and alternate lap splices are staggered by  $l_d$ .

**1912.17.2.3** Where the bar stress due to factored loads is greater than  $0.5f_y$  in tension, lap splices shall be Class B tension lap splices.

**1912.17.2.4** In tied reinforced compression members, where ties throughout the lap splice length have an effective area not less than  $0.0015hs$ , lap splice length may be multiplied by 0.83, but lap length shall not be less than 12 inches (305 mm). Tie legs perpendicular to dimension  $h$  shall be used in determining effective area.

**1912.17.2.5** In spirally reinforced compression members, lap splice length of bars within a spiral may be multiplied by 0.75, but lap length shall not be less than 12 inches (305 mm).

**1912.17.3 Welded splices or mechanical connectors in columns.** Welded splices or mechanical connectors in columns shall meet the requirements of Section 1912.14.3.3 or 1912.14.3.4.

**1912.17.4 End-bearing splices in columns.** End-bearing splices complying with Section 1912.16.4 may be used for column bars stressed in compression provided the splices are staggered or additional bars are provided at splice locations. The continuing bars in each face of the column shall have a tensile strength, based on the specified yield strength  $f_y$ , not less than  $0.2f_y$  times the area of the vertical reinforcement in that face.

**1912.18 Splices of Welded Deformed Wire Fabric in Tension.**

**1912.18.1** Minimum length of lap for lap splices of welded deformed wire fabric measured between the ends of each fabric sheet shall not be less than  $1.3l_d$  or 8 inches (203 mm), and the overlap measured between outermost cross wires of each fabric sheet shall not be less than 2 inches (51 mm),  $l_d$  shall be the development length for the specified yield strength  $f_y$  in accordance with Section 1912.7.

**1912.18.2** Lap splices of welded deformed wire fabric, with no cross wires within the lap splice length, shall be determined as for deformed wire.

**1912.19 Splices of Welded Smooth Wire Fabric in Tension.** Minimum length of lap for lap splices of welded smooth wire fabric shall be in accordance with the following:

**1912.19.1** When area of reinforcement provided is less than twice that required by analysis at splice location, length of overlap measured between outermost cross wires of each fabric sheet shall not be less than one spacing of cross wires plus 2 inches (51 mm), or less than  $1.5l_d$ , or 6 inches (152 mm),  $l_d$  shall be the development length for the specified yield strength  $f_y$  in accordance with Section 1912.8.

**1912.19.2** When area of reinforcement provided is at least twice that required by analysis at splice location, length of overlap measured between outermost cross wires of each fabric sheet shall not be less than  $1.5l_d$ , or 2 inches (51 mm),  $l_d$  shall be the development length for the specified yield strength  $f_y$  in accordance with Section 1912.8.

**SECTION 1913 — TWO-WAY SLAB SYSTEMS****1913.0 Notations.**

$C$  = cross-sectional constant to define torsional properties. See Formula (13-7).

$c_1$  = size of rectangular or equivalent rectangular column, capital, or bracket measured in the direction of the span for which moments are being determined, inches (mm).

$c_2$  = size of rectangular or equivalent rectangular column, capital or bracket measured transverse to the direction of the span for which moments are being determined, inches (mm).

$E_{cb}$  = modulus of elasticity of beam concrete.

$E_{cs}$  = modulus of elasticity of slab concrete.

$h$  = overall thickness of member, inches (mm).

$I_b$  = moment of inertia about centroidal axis of gross section of beam as defined in Section 1913.4.

$I_s$  = moment of inertia about centroidal axis of gross section of slab.  
=  $h^3/12$  times width of slab defined in notations  $\alpha$  and  $\beta$ .

$K_b$  = flexural stiffness of beam; moment per unit rotation.

$K_c$  = flexural stiffness of column; moment per unit rotation.

$K_s$  = flexural stiffness of slab; moment per unit rotation.

$K_t$  = torsional stiffness of torsional member; moment per unit rotation.

$l_n$  = length of clear span in direction that moments are being determined, measured face to face of supports.

$l_1$  = length of span in direction that moments are being determined, measured center to center of supports.

$l_2$  = length of span transverse to  $l_1$ , measured center to center of supports. See also Sections 1913.6.2.3 and 1913.6.2.4.

$M_o$  = total factored static moment.

- $M_u$  = factored moment at section.  
 $w_d$  = factored dead load per unit area.  
 $w_l$  = factored live load per unit area.  
 $w_u$  = factored load per unit area.  
 $x$  = shorter overall dimension of rectangular part of cross section.  
 $y$  = longer overall dimension of rectangular part of cross section.  
 $\alpha$  = ratio of flexural stiffness of beam section to flexural stiffness of a width of slab bounded laterally by center lines of adjacent panels (if any) on each side of the beam.  

$$= \frac{E_{cb}I_b}{E_{cs}I_s}$$
 $\alpha_c$  = ratio of flexural stiffness of columns above and below the slab to combined flexural stiffness of the slabs and beams at a joint taken in the direction of the span for which moments are being determined.  

$$= \frac{\Sigma K_c}{\Sigma(K_s + K_b)}$$
 $\alpha_{min}$  = minimum  $\alpha_c$  to satisfy Section 1913.6.10, Item 1.  
 $\alpha_1$  =  $\alpha$  in direction of  $l_1$ .  
 $\alpha_2$  =  $\alpha$  in direction of  $l_2$ .  
 $\beta_d$  = ratio of dead load per unit area to live load per unit area (in each case without load factors).  
 $\beta_t$  = ratio of torsional stiffness of edge beam section to flexural stiffness of a width of slab equal to span length of beam, center to center of supports.  

$$= \frac{E_{cb}C}{2E_{cs}I_s}$$
 $\gamma_t$  = fraction of unbalanced moment transferred by flexure at slab-column connections. See Section 1913.3.3.2.  
 $\delta_s$  = factor defined by Formula (13-5). See Section 1913.6.10.

### 1913.1 Scope.

**1913.1.1** The provisions of this section shall apply for design of slab systems reinforced for flexure in more than one direction with or without beams between supports.

**1913.1.2** A slab system may be supported on columns or walls. If supported by columns the dimensions  $c_1$  and  $c_2$  and the clear span  $l_n$  shall be based on an effective support area defined by the intersection of the bottom surface of the slab, or the drop panel if there is one, with the largest right circular cone, right pyramid, or tapered wedge whose surfaces are located within the column and capital or bracket and are oriented no greater than 45 degrees to the axis of the column.

**1913.1.3** Solid slabs and slabs with recesses or pockets made by permanent or removable fillers between ribs or joists in two directions are included within the scope of this section.

**1913.1.4** Minimum thickness of slabs designed in accordance with this section shall be as required by Section 1909.5.3.

### 1913.2 Definitions.

**1913.2.1** Column strip is a design strip with a width on each side of a column center line equal to  $0.25l_2$  or  $0.25l_1$ , whichever is less. Column strip includes beams, if any.

**1913.2.2** Middle strip is a design strip bounded by two column strips.

**1913.2.3** A panel is bounded by column, beam or wall center lines on all sides.

**1913.2.4** For monolithic or fully composite construction, a beam includes that portion of slab on each side of the beam extending a distance equal to the projection of the beam above or below the slab, whichever is greater, but not greater than four times the slab thickness.

### 1913.3 Design Procedures.

**1913.3.1** A slab system may be designed by any procedure satisfying conditions of equilibrium and geometric compatibility if shown that the design strength at every section is at least equal to the required strength considering Sections 1909.2 and 1909.3 and that all serviceability conditions, including specified limits on deflections, are met.

**1913.3.1.1** For gravity loads, a slab system, including the slab and beams (if any) between supports and supporting columns or walls forming orthogonal frames, may be designed by either the direct design method of Section 1913.6 or the equivalent frame method of Section 1913.7.

**1913.3.1.2** For lateral loads, analysis of unbraced frames shall take into account effects of cracking and reinforcement on stiffness of frame members.

**1913.3.1.3** Results of the gravity load analysis may be combined with results of the lateral load analysis.

**1913.3.2** The slab and beams (if any) between supports shall be proportioned for factored moments prevailing at every section.

**1913.3.3** When gravity load, wind, earthquake or other lateral forces cause transfer of moment between slab and column, a fraction of the unbalanced moment shall be transferred by flexure in accordance with Sections 1913.3.2 and 1913.3.3.

**1913.3.3.1** Fraction of unbalanced moment not transferred by flexure shall be transferred by eccentricity of shear in accordance with Section 1911.12.6.

**1913.3.3.2** A fraction of the unbalanced moment given by  $\gamma_f M_u$  shall be considered to be transferred by flexure within an effective slab width between lines that are one and one-half slab or drop panel thickness ( $1.5h$ ) outside opposite faces of the column or capital, where  $M_u$  is the moment to be transferred and

$$\gamma_f = \frac{1}{1 + \frac{2}{3} \sqrt{b_1/b_2}} \quad (13-1)$$

**1913.3.3.3** Concentration of reinforcement over the column by closer spacing or additional reinforcement may be used to resist moment on the effective slab width.

**1913.3.4** Design for transfer of load from slab to supporting columns or walls through shear and torsion shall be in accordance with Section 1911.

### 1913.4 Slab Reinforcement.

**1913.4.1** Area of reinforcement in each direction for two-way slab systems shall be determined from moments at critical sections but shall not be less than required by Section 1907.12.

**1913.4.2** Spacing of reinforcement at critical sections shall not exceed two times the slab thickness, except for portions of slab area that may be of cellular or ribbed construction. In the slab over cellular spaces, reinforcement shall be provided as required by Section 1907.12.

**1913.4.3** Positive moment reinforcement perpendicular to a discontinuous edge shall extend to the edge of slab and have embedment, straight or hooked, at least 6 inches (152 mm) in spandrel beams, columns or walls.

**1913.4.4** Negative moment reinforcement perpendicular to a discontinuous edge shall be bent, hooked or otherwise anchored, in spandrel beams, columns or walls, to be developed at face of support according to provisions of Section 1912.

**1913.4.5** Where a slab is not supported by a spandrel beam or wall at a discontinuous edge or where a slab cantilevers beyond the support, anchorage of reinforcement may be within the slab.

**1913.4.6** In slabs with beams between supports with a value of  $\alpha$  greater than 1.0, special top and bottom slab reinforcement shall be provided at exterior corners in accordance with the following:

**1913.4.6.1** The special reinforcement in both top and bottom of slab shall be sufficient to resist a moment equal to the maximum positive moment (per foot of width) (per meter of width) in the slab.

**1913.4.6.2** Direction of moment shall be assumed parallel to the diagonal from the corner in the top of the slab and perpendicular to the diagonal in the bottom of the slab.

**1913.4.6.3** The special reinforcement shall be provided for a distance in each direction from the corner equal to one fifth the longer span.

**1913.4.6.4** In either the top or bottom of the slab, the special reinforcement may be placed in a single band in the direction of the moment or in two bands parallel to the sides of the slab.

**1913.4.7** Where a drop panel is used to reduce amount of negative moment reinforcement over the column of a flat slab, size of drop panel shall be in accordance with the following:

**1913.4.7.1** Drop panel shall extend in each direction from center line of support a distance not less than one sixth the span length measured from center to center of supports in that direction.

**1913.4.7.2** Projection of drop panel below the slab shall be at least one fourth the slab thickness beyond the drop.

**1913.4.7.3** In computing required slab reinforcement, thickness of drop panel below the slab shall not be assumed greater than one fourth the distance from edge of drop panel to edge of column or column capital.

#### **1913.4.8 Details of reinforcement in slabs without beams.**

**1913.4.8.1** In addition to the other requirements of Section 1913.4, reinforcement in slabs without beams shall have minimum extensions as prescribed in Figure 19-1.

**1913.4.8.2** Where adjacent spans are unequal, extension of negative moment reinforcement beyond the face of support as prescribed in Figure 19-1 shall be based on requirements of longer span.

**1913.4.8.3** Bent bars may be used only when depth-span ratio permits use of bends 45 degrees or less.

**1913.4.8.4** For slabs in frames not braced against sidesway, lengths of reinforcement shall be determined by analysis but shall not be less than those prescribed in Figure 19-1.

**1913.4.8.5** At least two of the column strip bottom bars or wires in each direction shall be continuous or spliced at the support with Class A splices or anchored within support. These bars shall pass through the column and shall be placed within the column core.

**1913.4.8.6** In lift-slab construction, at least two bonded bottom bars or wires in each direction shall pass through the shearhead or lifting collar as close to the column as practicable and be continuous or spliced with a Class A splice. At exterior columns, the reinforcement shall be anchored at the shearhead or lifting collar.

#### **1913.5 Openings in Slab Systems.**

**1913.5.1** Openings of any size may be provided in slab systems if shown by analysis that the design strength is at least equal to the required strength considering Sections 1909.2 and 1909.3, and that all serviceability conditions, including the specified limits on deflections, are met.

**1913.5.2** In lieu of special analysis as required by Section 1913.5.1, openings may be provided in slab systems without beams only in accordance with the following:

**1913.5.2.1** Openings of any size may be located in the area common to intersecting middle strips, provided total amount of reinforcement required for the panel without the opening is maintained.

**1913.5.2.2** In the area common to intersecting column strips, not more than one eighth the width of column strip in either span shall be interrupted by openings. An amount of reinforcement equivalent to that interrupted by an opening shall be added on the sides of the opening.

**1913.5.2.3** In the area common to one column strip and one middle strip, not more than one fourth the reinforcement in either strip shall be interrupted by openings. An amount of reinforcement equivalent to that interrupted by an opening shall be added on the sides of the opening.

**1913.5.2.4** Shear requirements of Section 1911.12.5 shall be satisfied.

### 1913.6 Direct Design Method.

**1913.6.1 Limitations.** Slab systems within the following limitations may be designed by the direct design method:

**1913.6.1.1** There shall be a minimum of three continuous spans in each direction.

**1913.6.1.2** Panels shall be rectangular with a ratio of longer to shorter span center-to-center supports within a panel not greater than 2.

**1913.6.1.3** Successive span lengths center-to-center supports in each direction shall not differ by more than one third the longer span.

**1913.6.1.4** Columns may be offset a maximum of 10 percent of the span (in direction of offset) from either axis between center lines of successive columns.

**1913.6.1.5** All loads shall be due to gravity only and uniformly distributed over an entire panel. Live load shall not exceed three times dead load.

**1913.6.1.6** For a panel with beams between supports on all sides, the relative stiffness of beams in two perpendicular directions

$$\frac{\alpha_1 l_2^2}{\alpha_2 l_1^2} \quad (13-2)$$

shall not be less than 0.2 or greater than 5.0.

**1913.6.1.7** Moment redistribution as permitted by Section 1908.4 shall not be applied for slab systems designed by the direct design method. See Section 1913.6.7.

**1913.6.1.8** Variations from the limitations of this section may be considered acceptable if demonstrated by analysis that requirements of Section 1913.3.1 are satisfied.

### 1913.6.2 Total factored static moment for a span.

**1913.6.2.1** Total factored static moment for a span shall be determined in a strip bounded laterally by center line of panel on each side of center line of supports.

**1913.6.2.2** Absolute sum of positive and average negative factored moments in each direction shall not be less than

$$M_o = \frac{w_u l_2 l_n^2}{8} \quad (13-3)$$

**1913.6.2.3** Where the transverse span of panels on either side of the center line of supports varies,  $l_2$  in Formula (13-3) shall be taken as the average of adjacent transverse spans.

**1913.6.2.4** When the span adjacent and parallel to an edge is being considered, the distance from edge to panel center line shall be substituted for  $l_2$  in Formula (13-3).

**1913.6.2.5** Clear span  $l_n$  shall extend from face to face of columns, capitals, brackets or walls. Value of  $l_n$  used in Formula (13-3) shall not be less than  $0.65l_1$ . Circular or regular polygon-shaped supports shall be treated as square supports with the same area.

**1913.6.3 Negative and positive factored moments.**

**1913.6.3.1** Negative factored moments shall be located at face of rectangular supports. Circular or regular polygon-shaped supports shall be treated as square supports with the same area.

**1913.6.3.2** In an interior span, total static moment  $M_o$  shall be distributed as follows:

- Negative factored moment . . . . . 0.65
- Positive factored moment . . . . . 0.35

**1913.6.3.3** In an end span, total factored static moment  $M_o$  shall be distributed as follows:

	(1)	(2)	(3)		(4)	(5)
	Exterior Edge Unrestrained	Slab with Beams between All Supports	Slab without Beams between Interior Supports		Exterior Edge Fully Restrained	
			Without Edge Beam	With Edge Beam		
Interior negative factored moment	0.75	0.70	0.70	0.70	0.65	
Positive factored moment	0.63	0.57	0.52	0.50	0.35	
Exterior negative factored moment	0	0.16	0.26	0.30	0.65	

**1913.6.3.4** Negative moment sections shall be designed to resist the larger of the two interior negative factored moments determined for spans framing into a common support unless an analysis is made to distribute the unbalanced moment in accordance with stiffness of a joining elements.

**1913.6.3.5** Edge beams or edges of slab shall be proportioned to resist in torsion their share of exterior negative factored moments.

**1913.6.3.6** For moment transfer between slab and an edge column in accordance with Section 1913.3.1, column strip nominal moment strength provided shall be used as the transfer moment for gravity load.

**1913.6.4 Factored moments in column strips.**

**1913.6.4.1** Column strips shall be proportioned to resist the following percentage of interior negative factored moments:

$l_2/l_1$	0.5	1.0	2.0
$(\alpha_1 l_2/l_1) = 0$	75	75	75
$(\alpha_1 l_2/l_1) \geq 1.0$	90	75	45

Linear interpolations shall be made between values shown.

**1913.6.4.2** Column strips shall be proportioned to resist the following percentage of exterior negative factored moments:

$l_2/l_1$		0.5	1.0	2.0
$(\alpha_1 l_2/l_1) = 0$	$\beta_t = 0$	100	100	100
	$\beta_t \geq 2.5$	75	75	75

$(\alpha_1 l_2 / l_1) \geq 1.0$	$\beta_t = 0$	100	100	100
	$\beta_t \geq 2.5$	90	75	45

Linear interpolations shall be made between values shown.

**1913.6.4.3** Where supports consist of columns or walls extending for a distance equal to or greater than three fourths the span length  $l_2$  used to compute  $M_o$ , negative moments shall be considered to be uniformly distributed across  $l_2$ .

**1913.6.4.4** Column strips shall be proportioned to resist the following percentage of positive factored moments:

$l_2 / l_1$	0.5	1.0	2.0
$(\alpha_1 l_2 / l_1) = 0$	60	60	60
$(\alpha_1 l_2 / l_1) \geq 1.0$	90	75	45

Linear interpolations shall be made between values shown:

**1913.6.4.5** For slabs with beams between supports, the slab portion of column strips shall be proportioned to resist that portion of column strip moments not resisted by beams.

#### 1913.6.5 Factored moments in beams.

**1913.6.5.1** Beams between supports shall be proportioned to resist 85 percent of column strip moments if  $(\alpha_1 l_2 / l_1)$  is equal to or greater than 1.0.

**1913.6.5.2** For values of  $(\alpha_1 l_2 / l_1)$  between 1.0 and zero, proportion of column strip moments resisted by beams shall be obtained by linear interpolation between 85 and zero percent.

**1913.6.5.3** In addition to moments calculated for uniform loads according to Sections 1913.6.2.2, 1913.6.5.1 and 1913.6.5.2, beams shall be proportioned to resist all moments caused by concentrated or linear loads applied directly to beams, including weight of projecting beam stem above or below the slab.

#### 1913.6.6 Factored moments in middle strips.

**1913.6.6.1** That portion of negative and positive factored moments not resisted by column strips shall be proportionately assigned to corresponding half middle strips.

**1913.6.6.2** Each middle strip shall be proportioned to resist the sum of the moments assigned to its two half middle strips.

**1913.6.6.3** A middle strip adjacent to and parallel with an edge supported by a wall shall be proportioned to resist twice the moment assigned to the half middle strip corresponding to the first row of interior supports.

**1913.6.7 Modification of factored moments.** Negative and positive factored moments may be modified by 10 percent, provided the total static moment for a panel in the direction considered is not less than that required by Formula (13-3).

#### 1913.6.8 Factored shear in slab systems with beams.

**1913.6.8.1** Beams with  $(\alpha_1 l_2 / l_1)$  equal to or greater than 1.0 shall be proportioned to resist shear caused by factored loads on tributary areas bounded by 45-degree lines drawn from the corners of the panels and the center lines of the adjacent panels parallel to the long sides.

**1913.6.8.2** Beams with  $(\alpha_1 l_2 / l_1)$  less than 1.0 may be proportioned to resist shear obtained by linear interpolation, assuming beams carry no load at  $\alpha$  equals 0.

**1913.6.8.3** In addition to shears calculated according to this section, beams shall be proportioned to resist shears caused by factored loads applied directly on beams.

**1913.6.8.4** Slab shear strength may be computed on the assumption that load is distributed to supporting beams in accordance with the preceding paragraph. Resistance to total shear occurring on a panel shall be provided.

**1913.6.8.5** Shear strength shall satisfy requirements of Section 1911.

**1913.6.9 Factored moments in columns and walls.**

**1913.6.9.1** Columns and walls built integrally with a slab system shall resist moments caused by factored loads on the slab system.

**1913.6.9.2** At an interior support, supporting elements above and below the slab shall resist the moment specified by Formula (13-4) in direct proportion to their stiffnesses unless a general analysis is made.

$$M = 0.07 [(w_d + 0.5w_l)l_2l_n^2 - w'_dl'_2(l'_n)^2] \quad (13-4)$$

where  $w'_d$ ,  $l'_2$  and  $l'_n$  refer to shorter span.

**1913.6.10 Provisions for effects of pattern loadings.** Where ratio  $\beta_a$  of dead load to live load is less than 2, one of the following conditions shall be satisfied:

1. Sum of flexural stiffnesses of the columns above and below the slab shall be such that  $\alpha_c$  is not less than  $\alpha_{min}$  specified in Table 19-D.
2. If  $\alpha_c$  for the columns above and below the slab is less than  $\alpha_{min}$  specified in Table 19-D, positive factored moments in panels supported by such columns shall be multiplied by the coefficient  $\delta_s$  determined from Formula (13-5).

$$\delta_s = 1 + \frac{2 - \beta_a}{4 + \beta_a} \left( 1 - \frac{\alpha_c}{\alpha_{min}} \right) \quad (13-5)$$

where  $\beta_a$  is ratio of dead load to live load, per unit area (in each case without load factors).

**1913.7 Equivalent Frame Method.**

**1913.7.1** Design of slab systems by the equivalent frame method shall be based on assumptions given in Sections 1913.7.2 through 1913.7.6, and all sections of slabs and supporting members shall be proportioned for moments and shears thus obtained.

**1913.7.1.1** Where metal column capitals are used, account may be taken of their contributions to stiffness and resistance to moment and to shear.

**1913.7.1.2** Change in length of columns and slabs due to direct stress, and deflections due to shear, may be neglected.

**1913.7.2 Equivalent frame.**

**1913.7.2.1** The structure shall be considered to be made up of equivalent frames on column lines taken longitudinally and transversely through the building.

**1913.7.2.2** Each frame shall consist of a row of columns or supports and slab-beam strips, bounded laterally by the center line of panel on each side of the center line of columns or supports.

**1913.7.2.3** Columns or supports shall be assumed to be attached to slab-beam strips by torsional members (Section 1913.7.5) transverse to the direction of the span for which moments are being determined and extending to bounding lateral panel center lines on each side of a column.

**1913.7.2.4** Frames adjacent and parallel to an edge shall be bounded by that edge and the center line of adjacent panel.

**1913.7.2.5** Each equivalent frame may be analyzed in its entirety, or for gravity loading, each floor and the roof (slab-beams) may be analyzed separately with far ends of columns considered fixed.

**1913.7.2.6** Where slab-beams are analyzed separately, it may be assumed in determining moment at a given support that the slab-beam is fixed at any support two panels distant therefrom, provided the slab continues beyond that point.

**1913.7.3 Slab-beams.**

**1913.7.3.1** Moment of inertia of slab-beams at any cross section outside of joints or column capitals may be based on the gross area of concrete.

**1913.7.3.2** Variation in moment of inertia along axis of slab-beams shall be taken into account.

**1913.7.3.3** Moment of inertia of slab-beams from center of column to face of column, bracket or capital shall be assumed equal to the moment of inertia of the slab-beam at face of column, bracket or capital divided by the quantity  $(1 - c_2/l_2)^2$  where  $c_2$  and  $l_2$  are measured transverse to the direction of the span for which moments are being determined.

**1913.7.4 Columns.**

**1913.7.4.1** Moment of inertia of columns at any cross section outside of joints or column capitals may be based on the gross area of concrete.

**1913.7.4.2** Variation in moment of inertia along axis of columns shall be taken into account.

**1913.7.4.3** Moment of inertia of columns from top to bottom of the slab-beam at a joint shall be assumed infinite.

**1913.7.5 Torsional members.**

**1913.7.5.1** Torsional members shall be assumed to have a constant cross section throughout their length consisting of the larger of:

1. A portion of slab having a width equal to that of the column, bracket or capital in the direction of the span for which moments are being determined.
2. For monolithic or fully composite construction, the portion of slab specified in A above plus that part of the transverse beam above and below the slab.
3. Transverse beam as defined in Section 1913.2.4.

**1913.7.5.2** Stiffness  $K_t$  of an attached torsional member shall be calculated by the following expression:

$$K_t = \Sigma \frac{9E_{cs}C}{l_2 \left(1 - \frac{c_2}{l_2}\right)^3} \quad (13-6)$$

where  $c_2$  and  $l_2$  relate to the transverse spans on each side of column.

**1913.7.5.3** The constant  $C$  in Formula (13-6) may be evaluated for the cross section by dividing it into separate rectangular parts and carrying out the following summation:

$$C = \Sigma \left(1 - 0.63 \frac{x}{y}\right) \frac{x^3y}{3} \quad (13-7)$$

**1913.7.5.4** Where beams frame into columns in the direction of the span for which moments are being determined, value of  $K_t$  as computed by Formula (13-6) shall be multiplied by the ratio of moment of inertia of slab with such beam to moment of inertia of slab without such beam.

**1913.7.6 Arrangement of live load.**

**1913.7.6.1** When loading pattern is known, the equivalent frame shall be analyzed for that load.

**1913.7.6.2** When live load is variable but does not exceed three fourths the dead load, or the nature of live load is such that all panels will be loaded simultaneously, maximum factored moments may be assumed to occur at all sections with full factored live load on entire slab system.

**1913.7.6.3** For loading conditions other than those defined in the preceding paragraph, maximum positive factored moment near midspan of a panel may be assumed to occur with three fourths the full factored live load on the panel and on alternate panels; and maximum negative factored moment in the slab at a support may be assumed to occur with three fourths the full live load on adjacent panels only. Factored moments shall not be taken less than those occurring with full factored live load on all panels.

**1913.7.7 Factored moments.**

**1913.7.7.1** At interior supports, critical section for negative factored moment (in both column and middle strips) shall be taken at face of rectilinear supports, but not greater than  $0.175l_1$  from center of a column.

**1913.7.7.2** At exterior supports provided with brackets or capitals, critical section for negative factored moment in the span perpendicular to an edge shall be taken at a distance from face of supporting element not greater than one half the projection of bracket or capital beyond face of supporting element.

**1913.7.7.3** Circular or regular polygon-shaped supports shall be treated as square supports with the same area for location of critical section for negative design moment.

**1913.7.7.4** Slab systems within limitations of Section 1913.6.1, when analyzed by the equivalent frame method, may have resulting computed moments reduced in such proportion that the absolute sum of the positive and average negative moments used in design need not exceed the value obtained from Formula (13-3).

**1913.7.7.5** Moments at critical sections across the slab-beam strip of each frame may be distributed to column strips, beams and middle strips as provided in Sections 1913.6.4, 1913.6.5 and 1913.6.6 if the requirement of Section 1913.6.1.6 is satisfied.

**SECTION 1914 — WALLS**

**1914.0 Notations.**

$A_g$  = gross area of section, square inches ( $\text{mm}^2$ ).

$f'_c$  = specified compressive strength of concrete, pounds per square inch (MPa).

$h$  = overall thickness of member, inches (mm).

$k$  = effective length factor.

$l_c$  = vertical distance between supports, inches (mm).

$M_{cr}$  = cracking moment  $5\sqrt{f'_c}I_g/y_i$ , (For SI:  $0.42\sqrt{f'_c}I_g/y_i$ ) for regular concrete.

$M_n$  = nominal moment strength at section, inch-pound ( $N\cdot m$ ).

$M_u$  = factored moment at section, inch-pound ( $N\cdot m$ ). See Section 1914.8.3.

$P_{nw}$  = nominal axial load strength of wall designed by Section 1914.4.

$P_u$  = factored axial load at midheight of wall, including tributary wall weight.

$\rho$  = ratio of nonprestressed tension reinforcement.

$\rho_b$  = reinforcement ratio producing balanced strain conditions. See Formula (8-1).

$\phi$  = strength-reduction factor. See Section 1909.3.

**1914.1 Scope.**

**1914.1.1** Provisions of Section 1914 shall apply for design of walls subjected to axial load, with or without flexure.

**1914.1.2** Cantilever retaining walls are designed according to flexural design provisions of Section 1910 with minimum horizontal reinforcement according to Section 1914.3.3.

**1914.2 General.**

**1914.2.1** Walls shall be designed for eccentric loads and any lateral or other loads to which they are subjected.

**1914.2.2** Walls subject to axial loads shall be designed in accordance with Sections 1914.2, 1914.3 and either Section 1914.4 or 1914.5.

**1914.2.3** Design for shear shall be in accordance with Section 1911.10.

**1914.2.4** Unless demonstrated by a detailed analysis, horizontal length of wall to be considered as effective for each concentrated load shall not exceed center-to-center distance between loads, or width of bearing plus four times the wall thickness.

**1914.2.5** Compression members built integrally with walls shall conform to Section 1910.8.2.

**1914.2.6** Walls shall be anchored to intersecting elements such as floors or roofs or to columns, pilasters, buttresses, and intersecting walls and footings.

**1914.2.7** Quantity of reinforcement and limits of thickness required by Sections 1914.3 and 1914.5 may be waived where structural analysis shows adequate strength and stability.

**1914.3 Minimum Reinforcement.**

**1914.3.1** Minimum vertical and horizontal reinforcement shall be in accordance with Sections 1914.3.2 and 1914.3.3 unless a greater amount is required for shear by Sections 1911.10.8 and 1911.10.9.

**1914.3.2** Minimum ratio of vertical reinforcement area to gross concrete area shall be:

1. 0.0012 for deformed bars not larger than No. 5 with a specified yield strength not less than 60,000 psi (413.7 MPa), or
2. 0.0015 for other deformed bars, or
3. 0.0012 for welded wire fabric (plain or deformed) not larger than W31 or D31.

**1914.3.3** Minimum ratio of horizontal reinforcement area to gross concrete area shall be:

1. 0.0020 for deformed bars not larger than No. 5 with a specified yield strength not less than 60,000 psi (413.7 MPa), or
2. 0.0025 for other deformed bars, or
3. 0.0020 for welded wire fabric (plain or deformed) not larger than W31 or D31.

**1914.3.4** Walls more than 10 inches (254 mm) thick, except basement walls, shall have reinforcement for each direction placed in two layers parallel with faces of wall in accordance with the following:

1. One layer consisting of not less than one half and not more than two thirds of total reinforcement required for each direction shall be placed not less than 2 inches (51 mm) or more than one third the thickness of wall from exterior surface.
2. The other layer, consisting of the balance of required reinforcement in that direction, shall be placed not less than  $\frac{3}{4}$  inch (19 mm) or more than one third the thickness of wall from interior surface.

**1914.3.5** Vertical and horizontal reinforcement shall not be spaced farther apart than three times the wall thickness, nor 18 inches (457 mm).

**1914.3.6** Vertical reinforcement need not be enclosed by lateral ties if vertical reinforcement area is not greater than 0.01 times gross concrete area, or where vertical reinforcement is not required as compression reinforcement.

**1914.3.7** In addition to the minimum reinforcement required by Section 1914.3.1, not less than two No. 5 bars shall be provided around all window and door openings. Such bars shall be extended to develop the bar beyond the corners of the openings but not less than 24 inches (610 mm).

**1914.3.8** *The minimum requirements for horizontal and vertical steel of Sections 1914.3.2 and 1914.3.3 may be interchanged for precast panels which are not restrained along vertical edges to inhibit temperature expansion or contraction.*

**1914.4 Walls Designed as Compression Members.** Except as provided in Section 1914.5, walls subject to axial load or combined flexure and axial load shall be designed as compression members in accordance with provisions of Sections 1910.2, 1910.3, 1910.10, 1910.11, 1910.12, 1910.15, 1914.2 and 1914.3.

#### 1914.5 Empirical Design Method.

**1914.5.1** Walls of solid rectangular cross section may be designed by the empirical provisions of Section 1914.5 if resultant of all factored loads is located within the middle third of the overall thickness of wall and all limits of Sections 1914.2, 1914.3 and 1914.5 are satisfied.

**1914.5.2** Design axial load strength  $\phi P_{nw}$  of a wall satisfying limitations of Section 1914.5.1 shall be computed by Formula (14-1) unless designed in accordance with Section 1914.4.

$$\phi P_{nw} = 0.55 \phi f'_c A_g \left[ 1 - \left( \frac{kl_c}{32h} \right)^2 \right] \quad (14-1)$$

where  $\phi = 0.70$  and effective length factor  $k$  shall be:

For walls braced top and bottom against lateral translation and

1. Restrained against rotation at one or both ends (top and/or bottom) 0.8
2. Unrestrained against rotation at both ends 1.0

For walls not braced against lateral translation 2.0

#### 1914.5.3 Minimum thickness of walls designed by empirical design method.

**1914.5.3.1** Thickness of bearing walls shall not be less than  $1/25$  the supported height or length, whichever is shorter, or not less than 4 inches (102 mm).

**1914.5.3.2** Thickness of exterior basement walls and foundation walls shall not be less than  $7\frac{1}{2}$  inches (191 mm).

#### 1914.6 Nonbearing Walls.

**1914.6.1** Thickness of nonbearing walls shall not be less than 4 inches (102 mm), or not less than  $1/30$  the least distance between members that provide lateral support.

#### 1914.7 Walls as Grade Beams.

**1914.7.1** Walls designed as grade beams shall have top and bottom reinforcement as required for moment in accordance with provisions of Sections 1910.2 through 1910.7. Design for shear shall be in accordance with provisions of Section 1911.

**1914.7.2** Portions of grade beam walls exposed above grade shall also meet requirements of Section 1914.3.

#### 1914.8 Alternate Design Slender Walls.

**1914.8.1** *When flexural tension controls design of walls, the requirements of Section 1910.10 may be satisfied by complying with the limitations and procedures set forth in this section.*

**1914.8.2** The following limitations apply when this section is employed.

1. Vertical service load stress at the location of maximum moment does not exceed  $0.04 f'_c$ .
2. The reinforcement ratio  $\rho$  does not exceed  $0.6 \rho_b$ .
3. Sufficient reinforcement is provided so that the nominal moment capacity times the  $\phi$  factor is greater than  $M_{cr}$ .
4. Distribution of concentrated load does not exceed the width of bearing plus a width increasing at a slope of 2 vertical to 1 horizontal down to the design flexural section.

**1914.8.3** The required factored moment,  $M_u$  at the midheight cross section for combined axial and lateral factored loads, including the  $P \Delta$  moments, shall be as set forth in Formula (14-2).

$$M_u \leq \phi M_n \quad (14-2)$$

Unless a more comprehensive analysis is used, the  $P \Delta$  moment shall be calculated using the maximum potential deflection,  $\Delta_n$ , as defined in Section 1914.8.4.

**1914.8.4** The midheight deflection  $\Delta_s$ , under service lateral and vertical loads (without load factors), shall be limited by the relation

$$\Delta_s = \frac{l_c}{150} \quad (14-3)$$

Unless a more comprehensive analysis is used, the midheight deflection shall be computed with the following formulas:

$$\Delta_s = \Delta_{cr} + \left( \frac{M_s - M_{cr}}{M_n - M_{cr}} \right) (\Delta_n - \Delta_{cr}); \text{ for } M_s > M_{cr} \quad (14-4)$$

$$\Delta_s = \frac{5M_s l_c^2}{48E_c I_g}; \text{ for } M_s < M_{cr} \quad (14-5)$$

**WHERE:**

$$A_{se} = \frac{P_u + A_s f_y}{f_y}$$

$$I_{cr} = nA_{se}(d - c)^2 + \frac{bc^3}{3}$$

$M_s$  = the maximum moment in the wall resulting from the application of the unfactored load combinations.

$$\Delta_{cr} = \frac{5M_{cr} l_c^2}{48E_c I_g}$$

$$\Delta_n = \frac{5M_n l_c^2}{48E_c I_{cr}}$$

**SECTION 1915 — FOOTINGS**

**1915.0 Notations.**

$A_g$  = gross area of section, square inches ( $\text{mm}^2$ ).

$d_p$  = diameter of pile at footing base.

$\beta$  = ratio of long side to short side of footing.

**1915.1 Scope.**

**1915.1.1** Provisions of this section shall apply for design of isolated footings and, where applicable, to combined footings and mats.

**1915.1.2** Additional requirements for design of combined footings and mats are given in Section 1915.10.

**1915.2 Loads and Reactions.**

**1915.2.1** Footings shall be proportioned to resist the factored loads and induced reactions, in accordance with the appropriate design requirements of this code and as provided in this section.

**1915.2.2** Base area of footing or number and arrangement of piles shall be determined from the external forces and moments (transmitted by footing to soil or piles) and permissible soil pressure or permissible pile capacity selected through principles of soil mechanics. *External forces and moments are those resulting from unfactored loads (D, L, W and E) specified in Chapter 16.*

**1915.2.3** For footings on piles, computations for moments and shears may be based on the assumption that the reaction from any pile is concentrated at pile center.

**1915.2.4** *External forces and moments applied to footings shall be transferred to supporting soil without exceeding permissible soil pressures.*

**1915.3 Footings Supporting Circular or Regular Polygon-shaped Columns or Pedestals.** For location of critical sections for moment, shear and development of reinforcement in footings, it is permissible to treat circular or regular polygon-shaped concrete columns or pedestals as square members with the same area.

**1915.4 Moment in Footings.**

**1915.4.1** External moment on any section of a footing shall be determined by passing a vertical plane through the footing and computing the moment of the forces acting over entire area of footing on one side of that vertical plane.

**1915.4.2** Maximum factored moment for an isolated footing shall be computed as prescribed in Section 1915.4.1 at critical sections located as follows:

1. At face of column, pedestal or wall, for footings supporting a concrete column, pedestal or wall.
2. Halfway between middle and edge of wall, for footings supporting a masonry wall.
3. Halfway between face of column and edge of steel base, for footings supporting a column with steel base plates.

**1915.4.3** In one-way footings, and two-way square footings, reinforcement shall be distributed uniformly across entire width of footing.

**1915.4.4** In two-way rectangular footings, reinforcement shall be distributed as follows:

**1915.4.4.1** Reinforcement in long direction shall be distributed uniformly across entire width of footing.

**1915.4.4.2** For reinforcement in short direction, a portion of the total reinforcement given by Formula (15-1) shall be distributed uniformly over a band width (centered on center line of column or pedestal) equal to the length of short side of footing. Remainder of reinforcement required in short direction shall be distributed uniformly outside center band width of footing.

$$\frac{\text{Reinforcement in band width}}{\text{Total reinforcement in short direction}} = \frac{2}{(\beta + 1)} \quad (15-1)$$

**1915.5 Shear in Footings.**

**1915.5.1** Computation of shear in footings shall be in accordance with Section 1911.12.

**1915.5.2** Location of critical section for shear in accordance with Section 1911 shall be measured from face of column, pedestal or wall, for footings supporting a column, pedestal or wall. For foot-

ings supporting a column or pedestal with steel base plates, the critical section shall be measured from location defined in Section 1915.4.2, Item 3.

**1915.5.3** Computation of shear on any section through a footing supported on piles shall be in accordance with the following:

**1915.5.3.1** Entire reaction from any pile whose center is located  $d_p/2$  or more outside the section shall be considered as producing shear on that section.

**1915.5.3.2** Reaction from any pile whose center is located  $d_p/2$  or more inside the section shall be considered as producing no shear in that section.

**1915.5.3.3** For intermediate positions of pile center, the portion of the pile reaction to be considered as producing shear on the section shall be based on straight-line interpolation between full value at  $d_p/2$  outside the section and zero value at  $d_p/2$  inside the section.

### **1915.6 Development of Reinforcement in Footings.**

**1915.6.1** Development of reinforcement in footings shall be in accordance with Section 1912.

**1915.6.2** Calculated tension or compression in reinforcement at each section shall be developed on each side of that section by embedment length, hooks (tension only), mechanical device or combinations thereof.

**1915.6.3** Critical sections for development of reinforcement shall be assumed at the same locations as defined in Section 1915.4.2 for maximum factored moment, and at all other vertical planes where changes of section or reinforcement occur. See also Section 1912.10.6.

**1915.7 Minimum Footing Depth.** Depth of footing above bottom reinforcement shall not be less than 6 inches (152 mm) for footings on soil, or not less than 12 inches (305 mm) for footings on piles.

### **1915.8 Transfer of Force at Base of Column, Wall or Reinforced Pedestal.**

**1915.8.1** Forces and moments at base of column, wall, or pedestal shall be transferred to supporting pedestal or footing by bearing on concrete and by reinforcement, dowels and mechanical connectors.

**1915.8.1.1** Bearing on concrete at contact surface between supported and supporting member shall not exceed concrete bearing strength for either surface as given by Section 1910.15.

**1915.8.1.2** Reinforcement, dowels or mechanical connectors between supported and supporting members shall be adequate to transfer:

1. All compressive force that exceeds concrete bearing strength of either member.
2. Any computed tensile force across interface.

In addition, reinforcement, dowels or mechanical connectors shall satisfy Section 1915.8.2 or 1915.8.3.

**1915.8.1.3** If calculated moments are transferred to supporting pedestal or footing, reinforcement, dowels or mechanical connectors shall be adequate to satisfy Section 1912.17.

**1915.8.1.4** Lateral forces shall be transferred to supporting pedestal or footing in accordance with shear-friction provisions of Section 1911.7 or by other appropriate means.

**1915.8.2** In cast-in-place construction, reinforcement required to satisfy Section 1915.8.1 shall be provided either by extending longitudinal bars into supporting pedestal or footing, or by dowels.

**1915.8.2.1** For cast-in-place columns and pedestals, area of reinforcement across interface shall not be less than 0.005 times gross area of supported member.

**1915.8.2.2** For cast-in-place walls, area of reinforcement across interface shall not be less than minimum vertical reinforcement given in Section 1914.3.2.

**1915.8.2.3** At footings, No. 14 and No. 18 longitudinal bars, in compression only, may be lap spliced with dowels to provide reinforcement required to satisfy Section 1915.8.1. Dowels shall not be larger than No. 11 bar and shall extend into supported member a distance not less than the development length of No. 14 or No. 18 bars or the splice length of the dowels, whichever is greater, and into the footing a distance not less than the development length of the dowels.

**1915.8.2.4** If a pinned or rocker connection is provided in cast-in-place construction, connection shall conform to Sections 1915.8.1 and 1915.8.3.

**1915.8.3** In precast construction, reinforcement required to satisfy Section 1915.8.1 may be provided by anchor bolts or suitable mechanical connectors.

**1915.8.3.1** Connection between precast columns or pedestals and supporting member shall have a tensile strength not less than  $200 A_g$ , in pounds ( $1.38 A_g$ , in newtons), where  $A_g$  is area of supported member.

**1915.8.3.2** Precast wall *element base connections* shall have a tensile strength of not less than the calculated forces.

*EXCEPTION: In tilt-up construction, this connection may be to an adjacent floor slab. In no case shall the connection provided be less than that required by Section 1611.*

**1915.8.3.3** Anchor bolts and mechanical connectors shall be designed to reach their design strength prior to anchorage failure or failure of surrounding concrete.

#### **1915.9 Sloped or Stepped Footings.**

**1915.9.1** In sloped or stepped footings, angle of slope or depth and location of steps shall be such that design requirements are satisfied at every section.

**1915.9.2** Sloped or stepped footings designed as a unit shall be constructed to assure action as a unit.

#### **1915.10 Combined Footings and Mats.**

**1915.10.1** Footings supporting more than one column, pedestal or wall (combined footings or mats) shall be proportioned to resist the factored loads and induced reactions in accordance with appropriate design requirements of this code.

**1915.10.2** The direct design method of Section 1913 shall not be used for design of combined footings and mats.

**1915.10.3** Distribution of soil pressure under combined footings and mats shall be consistent with properties of the soil and the structure and with established principles of soil mechanics.

**1915.11 Plain Concrete Pedestals and Footings.** See Section 1923.

### **SECTION 1916 — PRECAST CONCRETE**

#### **1916.1 Scope.**

**1916.1.1** Provisions of this section shall apply only to design of precast concrete members *manufactured under plant-controlled conditions*.

**1916.1.2** All provisions of this code not specifically excluded, and not in conflict with provisions of Section 1617, shall apply to precast concrete.

#### **1916.2 Design.**

**1916.2.1** Design of precast members shall consider all loading and restraint conditions from initial fabrication to completion of the structure, including form removal, storage, transportation and erection.

**1916.2.2** In precast construction that does not behave monolithically, effects at all interconnected and adjoining details shall be considered to assure proper performance of the structural system.

**1916.2.3** Effects of initial and long-time deflections shall be considered including effects on interconnected elements.

**1916.2.4** Design of joints and bearings shall include effects of all forces to be transmitted, including shrinkage, creep, temperature, elastic deformation, wind and earthquake.

**1916.2.5** All details shall be designed to provide for manufacturing and erection tolerances and temporary erection stresses.

### **1916.3 Precast Wall Panels.**

**1916.3.1** Precast bearing and nonbearing walls shall be designed in accordance with provisions of Section 1914. *Design shall include effects of temperature and shrinkage.*

**1916.3.2** Where precast panels are designed to span horizontally to columns or isolated footings, the ratio of height to thickness shall not be limited, provided the effect of deep beam action, lateral buckling, *vertical buckling (including  $P \Delta$  effects)* and deflections are provided for in the design. See Sections 1910.7 and 1910.10.

### **1916.4 Details.**

**1916.4.1** All details of reinforcement, connections, bearing seats, inserts, anchors, concrete cover, openings, lifting devices, fabrication and erection tolerances shall be shown on the shop drawings.

**1916.4.2** When approved by the *building official*, embedded items (such as dowels or inserts) that either protrude from concrete or remain exposed for inspection may be embedded while concrete is in a plastic state, provided:

**1916.4.2.1** Embedded items are not required to be hooked or tied to reinforcement within plastic concrete.

**1916.4.2.2** Embedded items are maintained in correct position while concrete remains plastic, and

**1916.4.2.3** Embedded items are properly anchored to develop required factored loads.

### **1916.5 Identification and Marking.**

**1916.5.1** Each precast member or element shall be marked to indicate location in the structure, top surface and date of fabrication.

**1916.5.2** Identification marks shall correspond to the placing plans.

### **1916.6 Transportation, Storage and Erection.**

**1916.6.1** During curing, form removal, storage, transportation and erection, precast members shall not be overstressed, warped or otherwise damaged or have camber adversely affected.

**1916.6.2** Precast members shall be adequately braced and supported during erection to ensure proper alignment and structural integrity until permanent connections are completed.

## **SECTION 1917 — COMPOSITE CONCRETE FLEXURAL MEMBERS**

### **1917.0 Notations.**

$A_c$  = area of contact surface being investigated for horizontal shear, square inches ( $\text{mm}^2$ ).

$A_v$  = area of ties within a distance  $s$ , square inches ( $\text{mm}^2$ ).

$b_v$  = width of cross section at contact surface being investigated for horizontal shear.

- $d$  = distance from extreme compression fiber to centroid of tension reinforcement for entire composite section, inches (mm).  
 $h$  = overall thickness of composite members, inches (mm).  
 $s$  = spacing of ties measured along the longitudinal axis of the member, inches (mm).  
 $V_{nh}$  = nominal horizontal shear strength.  
 $V_u$  = factored shear force at section.  
 $\lambda$  = correction factor related to unit weight of concrete.  
 $\rho_v$  = ratio of tie reinforcement area to area of contact surface.  
     =  $A_v/b_v s$   
 $\phi$  = strength-reduction factor. See Section 1909.3.

### 1917.1 Scope.

**1917.1.1** Provisions of this section shall apply for design of composite concrete flexural members defined as precast or cast-in-place concrete elements or both constructed in separate placements but so interconnected that all elements respond to loads as a unit.

**1917.1.2** All provisions of this code shall apply to composite concrete flexural members, except as specifically modified in this section.

### 1917.2 General.

**1917.2.1** An entire composite member or portions thereof may be used in resisting shear and moment.

**1917.2.2** Individual elements shall be investigated for all critical stages of loading.

**1917.2.3** If the specified strength, unit weight or other properties of the various elements are different, properties of the individual elements or the most critical values shall be used in design.

**1917.2.4** In strength computations of composite members, no distinction shall be made between shored and unshored members.

**1917.2.5** All elements shall be designed to support all loads introduced prior to full development of design strength of composite members.

**1917.2.6** Reinforcement shall be provided as required to control cracking and to prevent separation of individual elements of composite members.

**1917.2.7** Composite members shall meet requirements for control of deflections in accordance with Section 1909.5.5.

**1917.3 Shoring.** When used, shoring shall not be removed until supported elements have developed design properties required to support all loads and limit deflections and cracking at time of shoring removal.

### 1917.4 Vertical Shear Strength.

**1917.4.1** When an entire composite member is assumed to resist vertical shear, design shall be in accordance with requirements of Section 1911 as for a monolithically cast member of the same cross-sectional shape.

**1917.4.2** Shear reinforcement shall be fully anchored into interconnected elements in accordance with Section 1912.13.

**1917.4.3** Extended and anchored shear reinforcement may be included as ties for horizontal shear.

### 1917.5 Horizontal Shear Strength.

**1917.5.1** In a composite member, full transfer of horizontal shear forces shall be assured at contact surfaces of interconnected elements.

**1917.5.1.1** Full transfer of horizontal shear forces may be assumed when all of the following are satisfied:

1. Contact surfaces are clean, free of laitance, and intentionally roughened to a full amplitude of approximately  $1/4$  inch (6.4 mm),
2. Minimum ties are provided in accordance with Section 1917.6,
3. Web members are designed to resist total vertical shear, and
4. All shear reinforcement is fully anchored into all interconnected elements.

**1917.5.1.2** If all requirements of Section 1917.5.1.1 are not satisfied, horizontal shear shall be investigated in accordance with Section 1917.5.2 or 1917.5.3.

**1917.5.2** Unless calculated in accordance with Section 1917.5.3, design of cross sections subject to horizontal shear shall be based on

$$V_u \leq \phi V_{nh} \quad (17-1)$$

where  $V_u$  is factored shear force at section considered and  $V_{nh}$  is nominal horizontal shear strength in accordance with the following:

**1917.5.2.1** When contact surfaces are clear, free of laitance and intentionally roughened, shear strength  $V_{nh}$  shall not be taken greater than  $80b_v d$ , in pounds ( $0.55 b_v d$ , in newtons).

**1917.5.2.2** When minimum ties are provided in accordance with Section 1917.6 and contact surfaces are clean and free of laitance, but not intentionally roughened, shear strength  $V_{nh}$  shall not be taken greater than  $80b_v d$ , in pounds ( $0.55 b_v d$ , in newtons).

**1917.5.2.3** When minimum ties are provided in accordance with Section 1917.6 and contact surfaces are clean, free of laitance, and intentionally roughened to a full amplitude of approximately  $1/4$  inch (6.4 mm), shear strength  $V_{nh}$  shall be taken equal to  $(260 + 0.6\rho_v f_y)b_v d$  in pounds [ $(1.79 + 0.6\rho_v f_y)b_v d$ , in newtons], but not greater than  $500 b_v d$  in pounds ( $3.5 b_v d$ , in newtons). Values for  $\lambda$  in Section 1911.7.4.3 shall apply.

**1917.5.2.4** When factored shear force  $V_u$  at section considered exceeds  $\phi(500b_v d)$  [For SI:  $\phi(3.5b_v d)$ ], design for horizontal shear shall be in accordance with Section 1917.5.3.

**1917.5.2.5** When determining nominal horizontal shear strength over prestressed concrete elements,  $d$  shall be as defined or  $0.8h$ , whichever is greater.

**1917.5.3** Horizontal shear may be investigated by computing the actual compressive or tensile force in any segment, and provisions made to transfer that force as horizontal shear to the supporting element. The factored horizontal shear force shall not exceed horizontal shear strength  $\phi V_{nh}$  as given in Sections 1917.5.2.1 through 1917.5.2.4 where area of contact surface  $A_c$  shall be substituted for  $b_v d$ .

**1917.5.3.1** When ties provided to resist horizontal shear are designed to satisfy Section 1917.5.3, the tie-area-to-tie-spacing ratio along the member shall approximately reflect the distribution of shear forces in the member.

**1917.5.4** When tension exists across any contact surface between interconnected elements, shear transfer by contact may be assumed only when minimum ties are provided in accordance with Section 1917.6.

## 1917.6 Ties for Horizontal Shear.

**1917.6.1** When ties are provided to transfer horizontal shear, tie area shall not be less than that required by Section 1911.5.5.3 and tie spacing shall not exceed four times the least dimension of supported element, or 24 inches (610 mm).

**1917.6.2** Ties for horizontal shear may consist of single bars or wire, multiple leg stirrups or vertical legs of welded wire fabric (plain or deformed).

**1917.6.3** All ties shall be fully anchored into interconnected elements in accordance with Section 1912.13.

## SECTION 1918 — PRESTRESSED CONCRETE

### 1918.0 Notations.

- $A$  = area of that part of cross section between flexural tension face and center of gravity of gross section, square inches ( $\text{mm}^2$ ).
- $A_{ps}$  = area of prestressed reinforcement in tension zone, square inches ( $\text{mm}^2$ ).
- $A_s$  = area of nonprestressed tension reinforcement, square inches ( $\text{mm}^2$ ).
- $A'_s$  = area of compression reinforcement, square inches ( $\text{mm}^2$ ).
- $b$  = width of compression face of member, inches (mm).
- $D$  = dead loads or related internal moments and forces.
- $d$  = distance from extreme compression fiber to centroid of nonprestressed tension reinforcement, inches (mm).
- $d'$  = distance from extreme compression fiber to centroid of compression reinforcement, inches (mm).
- $d_p$  = distance from extreme compression fiber to centroid of prestressed reinforcement.
- $e$  = base of Napierian logarithms.
- $f'_c$  = specified compressive strength of concrete, pounds per square inch (MPa).
- $\sqrt{f'_c}$  = square root of specified compressive strength of concrete, pounds per square inch; or *square root of compressive strength of concrete at time of initial prestress, pounds per square inch (MPa)*.
- $f'_{ci}$  = compressive strength of concrete at time of initial prestress, pounds per square inch (MPa).
- $f_{pc}$  = average compressive stress in concrete due to effective prestress force only (after allowance for all prestress losses), pounds per square inch (MPa).
- $f_{ps}$  = stress in prestressed reinforcement at nominal strength, pounds per square inch (MPa).
- $f_{pu}$  = specified tensile strength of prestressing tendons, pounds per square inch (MPa).
- $f_{py}$  = specified yield strength of prestressing tendons, pounds per square inch (MPa).
- $f_r$  = modulus of rupture of concrete, pounds per square inch (MPa).
- $f_{se}$  = effective stress in prestressed reinforcement (after allowance for all prestress losses), pounds per square inch (MPa).
- $f_y$  = specified yield strength of nonprestressed reinforcement, pounds per square inch (MPa).
- $h$  = overall thickness of member, inches (mm).
- $K$  = wobble friction coefficient per foot (per mm) of prestressing tendon.
- $L$  = live loads or related internal moments and forces.
- $l$  = length of span of two-way flat plates in direction parallel to that of the reinforcement being determined, inches (mm). See Formula (18-8).
- $l_x$  = length of prestressing tendon element from jacking end to any point  $x$ , feet (mm). See Formulas (18-1) and (18-2).
- $N_c$  = tensile force in concrete due to unfactored dead load plus live load ( $D + L$ ).
- $P_s$  = prestressing tendon force at jacking end.

- $P_x$  = prestressing tendon force at any point  $x$ .  
 $\alpha$  = total angular change of prestressing tendon profile in radians from tendon jacking end to any point  $x$ .  
 $\beta_1$  = factor defined in Section 1910.2.7.1.  
 $\gamma_p$  = factor for type of prestressing tendon.  
     = 0.55 for  $f_{py}/f_{pu}$  not less than 0.80.  
     = 0.40 for  $f_{py}/f_{pu}$  not less than 0.85.  
     = 0.28 for  $f_{py}/f_{pu}$  not less than 0.90.  
 $\mu$  = curvature friction coefficient.  
 $\rho$  = ratio of nonprestressed tension reinforcement.  
     =  $A_s/bd$ .  
 $\rho'$  = ratio of compression reinforcement.  
     =  $A'_s/bd$ .  
 $\rho_p$  = ratio of prestressed reinforcement.  
     =  $A_{ps}/bd_p$ .  
 $\phi$  = strength-reduction factor. See Section 1909.3.  
 $\omega$  =  $\rho f_y / f'_c$ .  
 $\omega'$  =  $\rho' f_y / f'_c$ .  
 $\omega_p$  =  $\rho_p f_{ps} / f'_c$ .  
 $\omega_w, \omega_{pw}, \omega'_w$   
     = reinforcement indices for flanged sections computed as for  $\omega, \omega_p$ , and  $\omega'$  except that  $b$  shall be the web width, and reinforcement area shall be that required to develop compressive strength of web only.

### 1918.1 Scope.

**1918.1.1** Provisions of this section shall apply to members prestressed with wire, strands or bars conforming to provisions for prestressing tendons.

**1918.1.2** All provisions of this code not specifically excluded, and not in conflict with provisions of this section, shall apply to prestressed concrete.

**1918.1.3** The following provisions of this code shall not apply to prestressed concrete, except as specifically noted: Sections 1907.6.5, 1908.4, 1908.10.2 through 1908.10.4, 1908.11, 1910.3.2 and 1910.3.3, 1910.5, 1910.6, 1910.9.1, 1913, 1914.3, 1914.5 and 1914.6.

### 1918.2 General.

**1918.2.1** Prestressed members shall meet the strength requirements specified in this code.

**1918.2.2** Design of prestressed members shall be based on strength and on behavior at service conditions at all load stages that may be critical during the life of the structure from the time prestress is first applied.

**1918.2.3** Stress concentrations due to prestressing shall be considered in design.

**1918.2.4** Provisions shall be made for effects on adjoining construction of elastic and plastic deformations, deflections, changes in length and rotations due to prestressing. Effects of temperature and shrinkage shall also be included.

**1918.2.5** Possibility of buckling in a member between points where concrete and prestressing tendons are in contact and of buckling in thin webs and flanges shall be considered.

**1918.2.6** In computing section properties prior to bonding of prestressing tendons, effect of loss of area due to open ducts shall be considered.

**1918.3 Design Assumptions.**

**1918.3.1** Strength design of prestressed members for flexure and axial loads shall be based on assumptions given in Section 1910.2, except Section 1910.2.4, shall apply only to reinforcement conforming to Section 1903.5.3.

**1918.3.2** For investigation of stresses at transfer of prestress, at service loads and at cracking loads, straight-line theory may be used with the following assumptions:

**1918.3.2.1** Strains vary linearly with depth through entire load range.

**1918.3.2.2** At cracked sections, concrete resists no tension.

**1918.4 Permissible Stresses in Concrete—Flexural Members.**

**1918.4.1** Stresses in concrete immediately after prestress transfer (before time-dependent prestress losses) shall not exceed the following:

- 1. Extreme fiber stress in compression .....  $0.60f'_{ci}$
- 2. Extreme fiber stress in tension except as permitted in Item 3 ...  $3\sqrt{f'_{ci}}$  (For SI:  $0.25\sqrt{f'_{ci}}$ )
- 3. Extreme fiber stress in tension at ends of simply supported members .....  $6\sqrt{f'_{ci}}$  (For SI:  $0.50\sqrt{f'_{ci}}$ )

Where computed tensile stresses exceed these values, bonded auxiliary reinforcement (nonprestressed or prestressed) shall be provided in the tensile zone to resist the total tensile force in concrete computed with the assumption of an uncracked section.

**1918.4.2** Stresses in concrete at service loads (after allowance for all prestress losses) shall not exceed the following:

- 1. Extreme fiber stress in compression .....  $0.45f'_c$
- 2. Extreme fiber stress in tension in precompressed tensile zone ...  $6\sqrt{f'_c}$  (For SI:  $0.50\sqrt{f'_c}$ )
- 3. Extreme fiber stress in tension in precompressed tensile zone of members (except two-way slab systems) where analysis based on transformed cracked sections and on bilinear moment-deflection relationships show that immediate and long-time deflections comply with requirements of Section 1909.5.4, and where cover requirements comply with Section 1907.7.3.2 .....  $12\sqrt{f'_c}$  (For SI:  $1.0\sqrt{f'_c}$ )

**1918.4.3** Permissible stresses in concrete of Sections 1918.4.1 and 1918.4.2 may be exceeded if shown by test or analysis that performance will not be impaired.

**1918.5 Permissible Stress in Prestressing Tendons.**

**1918.5.1** Tensile stress in prestressing tendons shall not exceed the following:

- 1. Due to tendon jacking force .....  $0.94f_{py}$   
but not greater than the lesser of  $0.80f_{pu}$  and the maximum value recommended by manufacturer of prestressing tendons or anchorages.
- 2. Immediately after prestress transfer .....  $0.82f_{py}$   
but not greater than  $0.74f_{pu}$ .
- 3. Posttensioning tendons, at anchorages and couplers, immediately after tendon anchorage .....  $0.70f_{pu}$

**1918.6 Loss of Prestress.**

**1918.6.1** To determine effective prestress  $f_{se}$ , allowance for the following sources of loss of prestress shall be considered:

1. Anchorage seating loss.
2. Elastic shortening of concrete.
3. Creep of concrete.
4. Shrinkage of concrete.
5. Relaxation of tendon stress.
6. Friction loss due to intended or unintended curvature in posttensioning tendons.

#### 1918.6.2 Friction loss in posttensioning tendons.

1918.6.2.1 Effect of friction loss in posttensioning tendons shall be computed by

$$P_s = P_x e^{(Kl_x + \mu\alpha)} \quad (18-1)$$

When  $(Kl \pm \mu\alpha)$  is not greater than 0.3, effect of friction loss may be computed by

$$P_s = P_x (1 + Kl_x + \mu\alpha) \quad (18-2)$$

1918.6.2.2 Friction loss shall be based on experimentally determined wobble  $K$  and curvature  $\mu$  friction coefficients and shall be verified during tendon stressing operations.

1918.6.2.3 Values of wobble and curvature coefficients used in design shall be shown on design drawings.

1918.6.3 Where loss of prestress in member may occur due to connection of member to adjoining construction, such loss of prestress shall be allowed for in design.

#### 1918.7 Flexural Strength.

1918.7.1 Design moment strength of flexural members shall be computed by the strength design methods of this chapter. For prestressing tendons,  $f_{ps}$  shall be substituted for  $f_y$  in strength computations.

1918.7.2 In lieu of a more accurate determination of  $f_{ps}$  based on strain compatibility, the following approximate values of  $f_{ps}$  shall be used if  $f_{se}$  is not less than  $0.5 f_{pu}$ .

1. For members with bonded prestressing tendons:

$$f_{ps} = f_{pu} \left( 1 - \frac{\gamma_p}{\beta_1} \left[ \rho_p \frac{f_{pu}}{f'_c} + \frac{d}{d_p} (\omega - \omega') \right] \right) \quad (18-3)$$

If any compression reinforcement is taken into account when calculating  $f_{ps}$  by Formula (18-3), the term

$$\left[ \rho_p \frac{f_{pu}}{f'_c} + \frac{d}{d_p} (\omega - \omega') \right]$$

shall be taken not less than 0.17 and  $d'$  shall be no greater than  $0.15 d_p$ .

2. For members with unbonded prestressing tendons and with a span-to-depth ratio of 35 or less:

$$f_{ps} = f_{se} + 10,000 + \frac{f'_c}{100\rho_p} \quad (18-4)$$

For SI: 
$$f_{ps} = f_{se} + 69 + \frac{f'_c}{100\rho_p}$$

but  $f_{ps}$  in Formula (18-4) shall not be taken greater than  $f_{py}$ , or  $(f_{se} + 60,000)$  (For SI:  $f_{se} + 413.7$ ).

3. For members with unbonded prestressing tendons and with a span-to-depth ratio greater than 35:

$$f_{ps} = f_{se} + 10,000 + \frac{f'_c}{300\rho_p} \quad (18-5)$$

For SI: 
$$f_{ps} = f_{se} + 69 + \frac{f'_c}{300\rho_p}$$

but  $f_{ps}$  in Formula (18-5) shall not be taken greater than  $f_{py}$ , or  $(f_{se} + 30,000)$  (For SI:  $f_{se} + 206.9$ ).

**1918.7.3** Nonprestressed reinforcement conforming to Section 1903.5.3, if used with prestressing tendons, may be considered to contribute to the tensile force and may be included in moment strength computations at a stress equal to the specified yield strength  $f_y$ . Other nonprestressed reinforcement may be included in strength computations only if a strain compatibility analysis is made to determine stresses in such reinforcement.

**1918.8 Limits for Reinforcement of Flexural Members.**

**1918.8.1** Ratio of prestressed and nonprestressed reinforcement used for computation of moment strength of a member, except as provided in this section shall be such that  $\omega_p$ ,  $[\omega_p + (d/d_p)(\omega - \omega')]$ , or  $[\omega_{pw} + (d/d_p)(\omega_w - \omega'_w)]$  is not greater than  $0.36 \beta_1$ .

**1918.8.2** When a reinforcement ratio in excess of that specified in this section is provided, design moment strength shall not exceed the moment strength based on the compression portion of the moment couple.

**1918.8.3** Total amount of prestressed and nonprestressed reinforcement shall be adequate to develop a factored load at least 1.2 times the cracking load computed on the basis of the modulus of rupture  $f_r$  specified in Section 1909.5.2, Item 3, except for flexural members with shear and flexural strength at least twice that required by Section 1909.2.

**1918.9 Minimum Bonded Reinforcement.**

**1918.9.1** A minimum area of bonded reinforcement shall be provided in all flexural members with unbonded prestressing tendons as required by Sections 1918.9.2 and 1918.9.3.

**1918.9.2** Except as provided in Section 1918.9.3, minimum area of bonded reinforcement shall be computed by

$$A_s = 0.004A \quad (18-6)$$

**1918.9.2.1** Bonded reinforcement required by Formula (18-6) shall be uniformly distributed over precompressed tensile zone as close as practicable to extreme tension fiber.

**1918.9.2.2** Bonded reinforcement shall be required regardless of service load stress conditions.

*One-way, unbonded, posttensioned slabs and beams shall be designed to carry the dead load of the slab or beam plus 25 percent of the unreduced superimposed live load by some method other than the primary unbonded posttensioned reinforcement. Design shall be based on the strength method of design with a load factor and capacity reduction factor of one. All reinforcement other than the primary unbonded reinforcement provided to meet other requirements of this section may be used in the design.*

**1918.9.2.3** *Maximum spacing limitations of Sections 1907.6.1 and 1908.10.5.2, for bonded reinforcement in slabs are not applicable to spacing of bonded reinforcement in members with unbonded tendons.*

**1918.9.3** For two-way flat plates, defined as solid slabs of uniform thickness, minimum area and distribution of bonded reinforcement shall be as follows:

**1918.9.3.1** Bonded reinforcement shall not be required in positive moment areas where computed tensile stress in concrete at service load (after allowance for prestress losses) does not exceed  $2\sqrt{f'_c}$  (For SI:  $0.166\sqrt{f'_c}$ ).

**1918.9.3.2** In positive moment areas where computed tensile stress in concrete at service load exceeds  $2\sqrt{f'_c}$  (For SI:  $0.166\sqrt{f'_c}$ ) minimum area of bonded reinforcement shall be computed by

$$A_s = \frac{N_c}{0.5f_y} \quad (18-7)$$

where design yield strength  $f_y$  shall not exceed 60,000 pounds per square inch (413.7 MPa). Bonded reinforcement shall be uniformly distributed over precompressed tensile zone as close as practicable to extreme tension fiber.

**1918.9.3.3** In negative moment areas at column supports, minimum area of bonded reinforcement in each direction shall be computed by

$$A_s = 0.00075hl \quad (18-8)$$

where  $l$  is length of span in direction parallel to that of the reinforcement being determined. Bonded reinforcement required by Formula (18-8) shall be distributed within a slab width between lines that are  $1.5h$  outside opposite faces of the column support. At least four bars or wires shall be provided in each direction. Spacing of bonded reinforcement shall not exceed 12 inches (305 mm).

**1918.9.4** Minimum length of bonded reinforcement required by Sections 1918.9.2 and 1918.9.3 shall be as follows:

**1918.9.4.1** In positive moment areas, minimum length of bonded reinforcement shall be one third the clear span length and centered in positive moment area.

**1918.9.4.2** In negative moment areas, bonded reinforcement shall extend one sixth the clear span on each side of support.

**1918.9.4.3** Where bonded reinforcement is provided for design moment strength in accordance with Section 1918.7.3, or for tensile stress conditions in accordance with Section 1918.9.3.2, minimum length also shall conform to provisions of Section 1912.

## 1918.10 Statically Indeterminate Structures.

**1918.10.1** Frames and continuous construction of prestressed concrete shall be designed for satisfactory performance at service load conditions and for adequate strength.

**1918.10.2** Performance at service load conditions shall be determined by elastic analysis, considering reactions, moments, shears, and axial forces produced by prestressing, creep, shrinkage, temperature change, axial deformation, restraint of attached structural elements and foundation settlement.

**1918.10.3** Moments to be used to compute required strength shall be the sum of the moments due to reactions induced by prestressing (with a load factor of 1.0) and the moments due to factored loads.

The sum of these moments may be adjusted as permitted in Section 1918.10.4.

### 1918.10.4 Redistribution of negative moments in continuous prestressed flexural members.

**1918.10.4.1** Where bonded reinforcement is provided at supports in accordance with Section 1918.9.2, negative moments calculated by elastic theory for any assumed loading arrangement may be increased or decreased by not more than

$$20 \left[ 1 - \frac{\omega_p + (d/d_p)(\omega - \omega')}{0.36\beta_1} \right] \text{percent}$$

**1918.10.4.2** The modified negative moments shall be used for calculating moments at sections within spans for the same loading arrangement.

**1918.10.4.3** Redistribution of negative moments shall be made only when the section at which moment is reduced is so designed that  $\omega_p$ ,  $[\omega_p + (d/d_p)(\omega - \omega')]$ , or  $[\omega_{pw} + (d/d_p)(\omega_w - \omega'_w)]$ , whichever is applicable, is not greater than  $0.24\beta_1$ .

**1918.11 Compression Members—Combined Flexure and Axial Loads.**

**1918.11.1** Prestressed concrete members subject to combined flexure and axial load, with or without nonprestressed reinforcement, shall be proportioned by the strength design methods of this chapter for members without prestressing. Effects of prestress, creep, shrinkage and temperature change shall be included.

**1918.11.2 Limits for reinforcement of prestressed compression members.**

**1918.11.2.1** Members with average prestress  $f_{pc}$  less than 225 psi (1.55 MPa) shall have minimum reinforcement in accordance with Sections 1907.10, 1910.9.1 and 1910.9.2 for columns, or Section 1914.3 for walls.

**1918.11.2.2** Except for walls, members with average prestress  $f_{pc}$  equal to or greater than 225 psi (1.55 MPa) shall have all prestressing tendons enclosed by spirals or lateral ties in accordance with the following:

1. Spirals shall conform to Section 1907.10.4.
2. Lateral ties shall be at least No. 3 in size or welded wire fabric of equivalent area, and spaced vertically not to exceed 48 tie bar or wire diameters or least dimension of compression member.
3. Ties shall be located vertically not more than half a tie spacing above top of footing or slab in any story, and shall be spaced as provided herein to not more than half a tie spacing below lowest horizontal reinforcement in members supported above.
4. Where beams or brackets frame into all sides of a column, ties may be terminated not more than 3 inches (76 mm) below lowest reinforcement in such beams or brackets.

**1918.11.2.3** For walls with average prestress  $f_{pc}$  equal to or greater than 225 pounds per square inch (1.55 MPa), minimum reinforcement required by Section 1914.3 may be waived where structural analysis shows adequate strength and stability.

**1918.12 Slab Systems.**

**1918.12.1** Factored moments and shears in prestressed slab systems reinforced for flexure in more than one direction shall be determined in accordance with provisions of Section 1913.7, excluding Sections 1913.7.7.4 and 1913.7.7.5, or by more detailed design procedures.

**1918.12.2** Moment strength of prestressed slabs at every section shall be at least equal to the required strength considering Sections 1909.2, 1909.3, 1918.10.3 and 1918.10.4. Shear strength of prestressed slabs at columns shall be at least equal to the required strength considering Sections 1909.2, 1909.3, 1911.1, 1911.12.2 and 1911.12.6.2.

**1918.12.3** At service load conditions, all serviceability limitations, including specified limits on deflections, shall be met, with appropriate consideration of the factors listed in Section 1918.10.2.

**1918.12.4** For normal live loads and load uniformly distributed, spacing of prestressing tendons or groups of tendons in one direction shall not exceed eight times the slab thickness, or 5 feet (1524 mm). Spacing of tendons also shall provide a minimum average prestress, after allowance for all prestress losses, of 125 psi (0.86 MPa) on the slab section tributary to the tendon or tendon group. A minimum of two tendons shall be provided in each direction through the critical shear section over columns. Special consideration of tendon spacing shall be provided for slabs with concentrated loads.

**1918.12.5** In slabs with unbonded prestressing tendons, bonded reinforcement shall be provided in accordance with Sections 1918.9.3 and 1918.9.4.

**1918.12.6** In lift slabs, bonded bottom reinforcement shall be detailed in accordance with the last paragraph of Section 1913.4.8.6.

**1918.13 Tendon Anchorage Zones.**

**1918.13.1** Reinforcement shall be provided where required in tendon anchorage zones to resist bursting, splitting and spalling forces induced by tendon anchorages. Regions of abrupt change in section shall be adequately reinforced.

**1918.13.2** End blocks shall be provided where required for support bearing or for distribution of concentrated prestressing forces.

**1918.13.3** Posttensioning anchorages and supporting concrete shall be designed to resist maximum jacking force for strength of concrete at time of prestressing.

**1918.13.4** Posttensioning anchorage zones shall be designed to develop the guaranteed ultimate tensile strength of prestressing tendons using a strength-reduction factor  $\phi$  of 0.90 for concrete.

**1918.14 Corrosion Protection for Unbonded Prestressing Tendons.**

**1918.14.1** Unbonded tendons shall be completely coated with suitable material to ensure corrosion protection.

**1918.14.2** Tendon cover shall be continuous over entire length to be unbonded, and shall prevent intrusion of cement paste or loss of coating materials during concrete placement.

**1918.14.3** Unbonded single strand tendons shall be protected against corrosion.

**1918.15 Posttensioning Ducts.**

**1918.15.1** Ducts for grouted or unbonded tendons shall be mortar-tight and nonreactive with concrete, tendons or filler materials.

**1918.15.2** Ducts for grouted single wire, strand or bar tendons shall have an inside diameter at least  $\frac{1}{4}$  inch (6.4 mm) larger than tendon diameter.

**1918.15.3** Ducts for grouted multiple wire, strand or bar tendons shall have an inside cross-sectional area at least two times the area of tendons.

**1918.15.4** Ducts shall be maintained free of water if members to be grouted are exposed to temperatures below freezing prior to grouting.

**1918.16 Grout for Bonded Prestressing Tendons.**

**1918.16.1** Grout shall consist of portland cement and water; or portland cement, sand and water.

**1918.16.2** Materials for grout shall conform to the following:

**1918.16.2.1** Portland cement shall conform to Section 1903.2.

**1918.16.2.2** Water shall conform to Section 1903.4.

**1918.16.2.3** The gradation sand may be modified as necessary to obtain satisfactory workability.

**1918.16.2.4** Admixtures conforming to Section 1903.6 and known to have no injurious effects on grout, steel or concrete may be used. Calcium chloride shall not be used.

**1918.16.3 Selection of grout proportions.**

**1918.16.3.1** Proportions of materials for grout shall be based on either of the following:

1. Results of tests on fresh and hardened grout prior to beginning grouting operations, or
2. Prior documented experience with similar materials and equipment and under comparable field conditions.

**1918.16.3.2** Cement used in the work shall correspond to that on which selection of grout proportions was based.

**1918.16.3.3** Water content shall be the minimum necessary for proper pumping of grout; however, water-cementitious materials ratio shall not exceed 0.45 by weight.

**1918.16.3.4** Water shall not be added to increase grout flowability that has been decreased by delayed use of grout.

**1918.16.4 Mixing and pumping grout.**

**1918.16.4.1** Grout shall be mixed in equipment capable of continuous mechanical mixing and agitation that will produce uniform distribution of materials, passed through screens, and pumped in a manner that will completely fill tendon ducts.

**1918.16.4.2** Temperature of members at time of grouting shall be above 35°F. (1.7°C.) and shall be maintained above 35°F. (1.7°C.) until field-cured 2-inch (51 mm) cubes of grout reach a minimum compressive strength of 800 pounds per square inch (5.52 MPa).

**1918.16.4.3** Grout temperatures shall not be above 90°F. (32.2°C.) during mixing and pumping.

**1918.17 Protection for Prestressing Tendons.** Burning or welding operations in vicinity of prestressing tendons shall be carefully performed so that tendons are not subject to excessive temperatures, welding sparks or ground currents.

**1918.18 Application and Measurement of Prestressing Force.**

**1918.18.1** Prestressing force shall be determined by both of the following methods:

1. Measurement of tendon elongation. Required elongation shall be determined from average load-elongation curves for the prestressing tendons used.
2. Observation of jacking force on a calibrated gauge or load cell or by use of a calibrated dynamometer.

Cause of any difference in force determination between 1 and 2 that exceeds 5 percent for pretensioned elements or 7 percent for post-tensioned construction shall be ascertained and corrected.

**1918.18.2** Where transfer of force from bulkheads of pretensioning bed to concrete is accomplished by flame cutting prestressing tendons, cutting points and cutting sequence shall be predetermined to avoid undesired temporary stresses.

**1918.18.3** Long lengths of exposed pretensioned strand shall be cut near the member to minimize shock to concrete.

**1918.18.4** Total loss of prestress due to unreplaced broken tendons shall not exceed 2 percent of total prestress.

**1918.19 Posttensioning Anchorages and Couplers.**

**1918.19.1** Anchorages and couplers for bonded and unbonded prestressed tendons shall develop at least 95 percent of the specified breaking strength of the tendons, when tested in an unbonded condition, without exceeding anticipated set.

For bonded tendons, anchorages and couplers shall be located so that 100 percent of the specified breaking strength of the tendons shall be developed at critical sections after tendons are bonded in the member.

**1918.19.2** Couplers shall be placed in areas approved by the *building official* and enclosed in housing long enough to permit necessary movements.

**1918.19.3** In unbonded construction subject to repetitive loads, special attention shall be given to the possibility of fatigue in anchorages and couplers.

**1918.19.4** Anchorages, couplers and end fittings shall be permanently protected against corrosion.

## SECTION 1919 — SHELLS AND FOLDED PLATES

### 1919.0 Notations.

- $E_c$  = modulus of elasticity of concrete, pounds per square inch (MPa). See Section 1908.5.1.  
 $f'_c$  = specified compressive strength of concrete, pounds per square inch (MPa).  
 $\sqrt{f'_c}$  = square root of specified compressive strength of concrete, pounds per square inch (MPa).  
 $f_y$  = specified yield strength of nonprestressed reinforcement, pounds per square inch (MPa).  
 $h$  = thickness of shell or folded plate, inches (mm).  
 $l_d$  = development length, inches (mm).  
 $\phi$  = strength-reduction factor. See Section 1909.3.

### 1919.1 Scope and Definitions.

**1919.1.1** Provisions of Section 1919 shall apply to thin-shell and folded-plate concrete structures, including ribs and edge members.

**1919.1.2** All provisions of Chapter 19 not specifically excluded, and not in conflict with provisions of Section 1919, shall apply to thin-shell structures.

**AUXILIARY MEMBERS** are ribs or edge beams which serve to strengthen, stiffen and/or support the shell; usually, auxiliary members act jointly with the shell.

**ELASTIC ANALYSIS** is an analysis of deformations and internal forces based on equilibrium, compatibility of strains and assumed elastic behavior and representing to suitable approximation the three-dimensional action of the shell together with its auxiliary members.

**EXPERIMENTAL ANALYSIS** is an analysis procedure based on the measurement of deformations and/or strains of the structure or its model; experimental analysis may be based on either elastic or inelastic behavior.

**FOLDED PLATES** are a special class of shell structures formed by joining flat, thin slabs along their edges so as to create a three-dimensional spatial structure.

**INELASTIC ANALYSIS** is an analysis of deformations and internal forces based on equilibrium, nonlinear stress-strain relations for concrete and reinforcement, consideration of cracking and time-dependent effects and compatibility of strains. The analysis shall represent to suitable approximation the three-dimensional action of the shell together with its auxiliary members.

**RIBBED SHELLS** are spatial structures with material placed primarily along certain preferred rib lines, with the area between the ribs filled with thin slabs or left open.

**THIN SHELLS** are three-dimensional spatial structures made up of one or more curved slabs or folded plates whose thicknesses are small compared to their other dimensions. Thin shells are characterized by their three-dimensional load-carrying behavior which is determined by the geometry of their forms, by the manner in which they are supported and by the nature of the applied load.

### 1919.2 Analysis and Design.

**1919.2.1** Elastic behavior shall be an accepted basis for determining internal forces and displacements of thin shells. This behavior may be established by computations based on an analysis of the uncracked concrete structure in which the material is assumed linearly elastic, homogeneous and isotropic. Poisson's ratio of concrete may be assumed equal to zero.

**1919.2.2** Inelastic analysis may be used where it can be shown that such methods provide a safe basis for design.

**1919.2.3** Equilibrium checks of internal resistances and external loads shall be made to ensure consistency of results.

**1919.2.4** Experimental or numerical analysis procedures may be used where it can be shown that such procedures provide a safe basis for design.

**1919.2.5** Approximate methods of analysis not satisfying compatibility of strains either within the shell or between the shell and auxiliary members may be used where it can be shown that such methods provide a safe basis for design.

**1919.2.6** In prestressed shells, the analysis must also consider behavior under loads induced during prestressing, at cracking load and at factored load. Where prestressing tendons are draped within a shell, design shall take into account force components on the shell resulting from tendon profile not lying in one plane.

**1919.2.7** The thickness  $h$  of a thin shell and its reinforcement shall be proportioned for the required strength and serviceability. All elements shall be proportioned by the same method, using either the strength design method of Section 1908.1.1 or the alternate design method of Section 1926.

**1919.2.8** Shell design shall investigate and preclude the possibility of general or local instability.

**1919.2.9** Auxiliary members shall be designed according to the applicable provisions of this code. The design method selected for shell elements under Section 1919.2.7 shall also be used for auxiliary members. A portion of the shell equal to the flange width specified in Section 1908.10 may be assumed to act with the auxiliary member. In such portions of the shell, the reinforcement perpendicular to the auxiliary member shall be at least equal to that required for the flange of a T-beam by Section 1908.10.5.

### **1919.3 Design Strength of Materials.**

**1919.3.1** Specified compressive strength of concrete  $f'_c$  at 28 days shall not be less than 3,000 psi (20.69 MPa).

**1919.3.2** Specified yield strength of nonprestressed reinforcement  $f_y$  shall not exceed 60,000 psi (413.7 MPa).

### **1919.4 Shell Reinforcement.**

**1919.4.1** Shell reinforcement shall be provided to resist tensile stresses from internal membrane forces, to resist bending and twisting moments, to control shrinkage and temperature cracking and as special reinforcement as shell boundaries, load attachments and shell openings.

**1919.4.2** Membrane reinforcement shall be provided in two or more directions in all parts of the shell.

**1919.4.3** The area of shell reinforcement at any section as measured in two orthogonal directions shall not be less than the slab shrinkage or temperature reinforcement required by Section 1907.12.

**1919.4.4** Reinforcement required to resist shell membrane forces shall be provided so that the design strength in every direction shall be at least equal to the component of the principal membrane forces in the same direction due to factored loads.

**1919.4.5** The area of shell tension reinforcement shall be limited so that the reinforcement will yield before crushing of concrete in compression can take place.

**1919.4.6** In regions of high tension, membrane reinforcement shall, if practical, be placed in the general directions of the principal tensile membrane forces. Where this is not practical, membrane reinforcement may be placed in two or more component directions.

**1919.4.7** If the direction of reinforcement varies more than 10 degrees from the direction of principal tensile membrane force, the amount of reinforcement may have to be increased to limit the width of possible cracks at service load levels.

**1919.4.8** Where the magnitude of the principal tensile membrane stress within the shell varies greatly over the area of the shell surface, reinforcement resisting the total tension may be concentrated in the regions of largest tensile stress where it can be shown that this provides a safe basis for design. However, the ratio of shell reinforcement in any portion of the tensile zone shall not be less than 0.0035 based on the overall thickness of the shell.

**1919.4.9** Reinforcement required to resist shell bending moments shall be proportioned with due regard to the simultaneous action of membrane axial forces at the same location. Where shell reinforcement is required in only one face to resist bending moments, equal amounts shall be placed near both surfaces of the shell even though a reversal of bending moments is not indicated by the analysis.

**1919.4.10** Shell reinforcement in any direction shall not be spaced farther apart than 18 inches (457 mm), or five times the shell thickness. Where the principal membrane tensile stress on the gross concrete area due to factored loads exceeds  $4\phi\sqrt{f'_c}$  (For SI:  $0.33\phi\sqrt{f'_c}$ ), reinforcement shall not be spaced farther apart than three times the shell thickness.

**1919.4.11** Shell reinforcement at the junction of the shell and supporting members or edge members shall be anchored in or extended through such members in accordance with the requirements of Section 1912, except that the minimum development length shall be  $1.2d$  but not less than 18 inches (457 mm).

**1919.4.12** Splice development lengths of shell reinforcement shall be governed by the provisions of Section 1912, except that the minimum splice length of tension bars shall be 1.2 times the value required by Section 1912 but not less than 18 inches (457 mm). The number of splices in principal tensile reinforcement shall be kept to a practical minimum. Where splices are necessary, they shall be staggered at least  $l_d$  with not more than one third of the reinforcement spliced at any section.

### 1919.5 Construction.

**1919.5.1** When removal of formwork is based on a specific modulus of elasticity of concrete because of stability or deflection considerations, the value of the modulus of elasticity  $E_c$  shall be determined from flexural tests of field-cured beam specimens. The number of test specimens, the dimensions of test beam specimens and test procedures shall be specified.

**1919.5.2** The tolerances for the shape of the shell shall be specified. If construction results in deviations from the shape greater than the specified tolerances, an analysis of the effect of the deviations shall be made and any required remedial actions shall be taken to ensure safe behavior.

## SECTION 1920 — STRENGTH EVALUATION OF EXISTING STRUCTURES

### 1920.0 Notations.

- $a$  = maximum deflection under test load of member relative to a line joining the ends of the span, or of the free end of cantilever relative to its support, inches (mm).
- $D$  = dead loads, or related internal moments and forces.
- $h$  = overall thickness of member, inches (mm).
- $L$  = live loads, or related internal moments and forces.
- $l_t$  = span of member under load test (shorter span of flat slabs and of slabs supported on four sides). Span of member, except as provided in Section 1920.4.9, is distance between centers of supports or clear distance between supports plus depth of member, whichever is smaller, inches (mm).

**1920.1 Strength Evaluation—General.** If doubt develops concerning the safety of a structure or member, or low-strength concrete or both is confirmed in accordance with Section 1905.6.4.4 and computations indicate that load-carrying capacity has been significantly reduced, the engineer or building official may order a load test.

**1920.2 Analytical Investigations—General.**

**1920.2.1** If strength evaluation is by analysis, a thorough field investigation shall be made of dimensions and details of members, properties of materials and other pertinent conditions of the structure as actually built.

**1920.2.2** Analyses based on investigation required by this subsection shall satisfy the building official that the load factors meet requirements and intent of this code. See Section 1920.6.

**1920.3 Load Tests—General.**

**1920.3.1** If strength evaluation is by load tests, a qualified engineer acceptable to the building official shall control such tests.

**1920.3.2** A load test shall not be made until that portion of the structure to be subject to load is at least 56 days old. When the owner of the structure, the contractor and all involved parties mutually agree, the test may be made at an earlier age.

**1920.3.3** When only a portion of the structure is to be load tested, the questionable portion shall be load tested in such a manner as to adequately test the suspected source of weakness.

**1920.3.4** Forty-eight hours prior to application of test load, a load to simulate effect of that portion of the dead loads not already acting shall be applied and shall remain in place until all testing has been completed.

**1920.4 Load Tests of Flexural Members.**

**1920.4.1** When flexural members, including beams and slabs, are load tested, the following additional provisions of this subsection shall apply.

**1920.4.2** Base readings (datum for deflection measurements) shall be made immediately prior to application of test load.

**1920.4.3** That portion of the structure selected for loading shall be subject to a total load, including dead loads already acting, equivalent to  $0.85(1.4D + 1.7L)$ . Determination of  $L$  shall include live load reductions as permitted by Section 1606.

**1920.4.4** Test load shall be applied in not less than four approximately equal increments without shock to the structure and in such a manner as to avoid arching of loading materials.

**1920.4.5** After test load has been in position for 24 hours, initial deflection readings shall be taken.

**1920.4.6** Test load shall be removed immediately after initial deflection readings, and final deflection readings shall be taken 24 hours after removal of the test load.

**1920.4.7** If the portion of the structure tested shows visible evidence of failure, the portion tested shall be considered to have failed the test and no retesting of the previously tested portion shall be permitted.

**1920.4.8** If the portion of the structure tested shows no visible evidence of failure, the following criteria shall be taken as indication of satisfactory behavior:

1. If measured maximum deflection  $a$  of a beam, floor or roof is less than  $l_t^2/20,000h$ .
2. If measured maximum deflection  $a$  of a beam, floor or roof exceeds  $l_t^2/20,000h$ , deflection recovery within 24 hours after removal of the test load shall be at least 75 percent of the maximum deflection for nonprestressed concrete, or 80 percent for prestressed concrete.

**1920.4.9** In Sections 1920.4.8, Items 1 and 2,  $l_t$  for cantilevers shall be taken as two times the distance from support to cantilever end, and deflection shall be adjusted for any support movement.

**1920.4.10** Nonprestressed concrete construction failing to show 75 percent recovery of deflection as required by Section 1920.4.8, Item 2, may be retested not earlier than 72 hours after removal of the first test load. The portion of the structure tested shall be considered satisfactory if:

1. The portion of the structure tested shows no visible evidence of failure in the retest, and
2. Deflection recovery caused by second test load is at least 80 percent of the maximum deflection in the second test.

**1920.4.11** Prestressed concrete construction shall not be retested.

**1920.5 Members Other Than Flexural Members.** Members other than flexural members preferably shall be investigated by analysis.

**1920.6 Provision for Lower Load Rating.** If the structure under investigation does not satisfy conditions or criteria of Sections 1920.2 and 1920.4.8 or 1920.4.10, the structure may be permitted for use at a lower load rating based on the results of the load test or analysis, if approved by the building official.

**1920.7 Safety.**

**1920.7.1** Load tests shall be conducted in such a manner as to provide for safety of life and structure during the test.

**1920.7.2** No safety measures shall interfere with load test procedures or affect results.

## SECTION 1921 — REINFORCED CONCRETE STRUCTURES RESISTING FORCES INDUCED BY EARTHQUAKE MOTIONS

**1921.0 Notations.**

- $A_{ch}$  = cross-sectional area of a structural member measured out-to-out of transverse reinforcement, square inches (mm<sup>2</sup>).
- $A_{cp}$  = area of concrete section, resisting shear, of an individual pier or horizontal wall segment, square inches (mm<sup>2</sup>).
- $A_{cv}$  = net area of concrete section bounded by web thickness and length of section in the direction of shear force considered, square inches (mm<sup>2</sup>).
- $A_g$  = gross area of section, square inches (mm<sup>2</sup>).
- $A_j$  = effective cross-sectional area within a joint (see Section 1921.5.3.1).
- $A_{sh}$  = total cross-sectional area of transverse reinforcement (including crossties) within spacing,  $s$ , and perpendicular to dimension,  $h_c$ .
- $b$  = effective compressive flange width of a structural member, inches (mm).
- $b_w$  = web width, or diameter of circular section, inches (mm).
- $d$  = effective depth of section.
- $d_b$  = bar diameter.
- $E$  = load effects of earthquake, or related internal moments and forces.
- $f'_c$  = specified compressive strength of concrete, psi (MPa).
- $f_y$  = specified yield strength of reinforcement, psi (MPa).
- $f_{yh}$  = specified yield strength of transverse reinforcement, psi (MPa).
- $h_c$  = cross-sectional dimension of a column core or shear wall boundary zone measured center-to-center of confining reinforcement.
- $h_w$  = height of entire wall (diaphragm) or of the segment of wall (diaphragm) considered.
- $l_d$  = development length for a straight bar.
- $l_{dh}$  = development length for a bar with a standard hook as defined in Formula (21-5).
- $l_o$  = minimum length, measured from joint face along axis of structural member, over which transverse reinforcement must be provided, inches (mm).

- $l_w$  = length of entire wall (diaphragm) or of segment of wall (diaphragm) considered in direction of shear force.
- $M_{pr}$  = probable flexural strength of members, with or without axial load, determined using the properties of the member at the joint faces assuming a tensile strength in the longitudinal bars of at least  $1.25 f_y$  and a strength-reduction factor  $\phi$  of 1.0.
- $M_s$  = portion of slab moment balanced by support moment.
- $s$  = spacing of transverse reinforcement measured along the longitudinal axis of the structural member, inches (mm).
- $s_o$  = maximum spacing of transverse reinforcement, inches (mm).
- $V_c$  = nominal shear strength provided by concrete.
- $V_e$  = design shear force determined from Section 1921.3.4.1 or 1921.4.5.1.
- $V_n$  = nominal shear strength.
- $V_u$  = factored shear force at section.
- $\alpha_c$  = coefficient defining the relative contribution of concrete strength to wall strength.
- $\rho$  = ratio of nonprestressed tension reinforcement  
=  $A_s/bd$ .
- $\rho_g$  = ratio of total reinforcement area to cross-sectional area of column.
- $\rho_n$  = ratio of distributed shear reinforcement on a plane perpendicular to plane of  $A_{cv}$ .
- $\rho_s$  = ratio of volume of spiral reinforcement to the core volume confined by the spiral reinforcement (measured out-to-out).
- $\rho_v$  =  $A_{sv}/A_{cv}$ ; where  $A_{sv}$  is the projection on  $A_{cv}$  of area of distributed shear reinforcement crossing the plane of  $A_{cv}$ .
- $\phi$  = strength-reduction factor.

**1921.1 Definitions.** For the purposes of this section, certain terms are defined as follows:

**BASE OF STRUCTURE** is the level at which earthquake motions are assumed to be imparted to a building. This level does not necessarily coincide with the ground level.

**BOUNDARY ELEMENTS** are portions along wall and diaphragm edges strengthened by longitudinal and transverse reinforcement. Boundary elements do not necessarily require an increase in the thickness of the wall or diaphragm. Edges of openings within walls and diaphragms shall be provided with boundary elements if required by Sections 1921.6.5.1 and 1921.6.6.1.

**COLLECTOR ELEMENTS** are elements that serve to transmit the inertial forces with the diaphragms to members of the lateral-force-resisting systems.

**CONFINED CORE** is the area within the core defined by  $h_c$ .

**CROSSTIE** is a continuous bar having a hook of not less than 135 degrees with an extension of not less than six diameters [but not less than 3 inches (76 mm)] at one end and a hook of not less than 90 degrees with an extension of not less than six diameters at the other end. The hooks shall engage peripheral longitudinal bars. The 90-degree hooks of two successive crossties engaging the same longitudinal bar shall be alternated end for end.

**DESIGN LOAD COMBINATIONS** are combinations of factored loads and forces specified in Sections 1909.2 and 1921.2.7.

**DEVELOPMENT LENGTH FOR A BAR WITH A STANDARD HOOK** is the shortest distance between the critical section (where the strength of the bar is to be developed) and a tangent to the outer edge of the 90-degree hook.

**FACTORED LOADS AND FORCES** are the specified loads and forces modified by the factors in Sections 1909.2 and 1921.2.7.

**HOOP** is a closed tie or continuously wound tie. A closed tie may be of several reinforcing elements with 135-degree hooks having a six-diameter [but not less than 3-inch (76 mm)] extension at each end. A continuously wound tie shall have at each end a 135-degree hook with a six-diameter [but not less than 3-inch (76 mm)] extension that engages the longitudinal reinforcement.

**LATERAL-FORCE-RESISTING SYSTEM** is that portion of the structure composed of members proportioned to resist forces related to earthquake effects.

**LIGHTWEIGHT-AGGREGATE CONCRETE** is all lightweight or sanded lightweight aggregate concrete made with lightweight aggregates conforming to Section 1903.5.

**SEISMIC HOOK** is a 135-degree bend with a six-bar-diameter, but not less than 3-inch (76 mm), extension that engages the longitudinal reinforcement and projects into the interior of the stirrup or hoop.

**SHELL CONCRETE** is concrete outside the transverse reinforcement confining the concrete.

**SPECIFIED LATERAL FORCES** are lateral forces corresponding to the appropriate distribution of the design base shear force prescribed by the governing code for earthquake-resistant design.

**STRUCTURAL DIAPHRAGMS** are structural members, such as floor and roof slabs, which transmit inertial forces to lateral-force-resisting members.

**STRUCTURAL TRUSSES** are assemblages of reinforced concrete members subjected primarily to axial forces.

**STRUT** is an element of a structural diaphragm used to provide continuity around an opening in the diaphragm.

**TIE ELEMENTS** are elements which serve to transmit inertia forces and prevent separation of such building components as footings and walls.

**WALL PIER** is a wall segment with a horizontal length-to-thickness ratio between 2.5 and 6, and whose clear height is at least two times its horizontal length.

## 1921.2 General Requirements.

### 1921.2.1 Scope.

**1921.2.1.1** Section 1921 contains special requirements for design and construction of reinforced concrete members of a structure for which the design forces, related to earthquake motions, have been determined on the basis of energy dissipation in the nonlinear range of response.

**1921.2.1.2** The provisions of Sections 1901 through 1918 shall apply except as modified by the provisions of Section 1921.

**1921.2.1.3** In Seismic Zones 0 and 1, the provisions of Section 1921 shall not apply.

*In Seismic Zone 2, reinforced concrete frames resisting forces induced by earthquake motions shall be intermediate moment-resisting frames proportioned to satisfy only Section 1921.8 in addition to the requirements of Sections 1901 through 1918. In Seismic Zone 2, frame members which are not designated to be part of the lateral-force-resisting system shall conform to Section 1921.7.2.*

**1921.2.1.4** In Seismic Zones 3 and 4, all structural reinforced concrete members that are part of the lateral-force-resisting system shall satisfy the requirements of Sections 1921.2 through 1921.7, in addition to the requirements of Sections 1901 through 1917.

**1921.2.1.5** A reinforced concrete structural system not satisfying the requirements of this section may be used if it is demonstrated by experimental evidence and analysis that the proposed system will have strength and toughness equal to or exceeding those provided by a comparable monolithic reinforced concrete structure satisfying this section.

**1921.2.2 Analysis and proportioning of structural members.**

**1921.2.2.1** The interaction of all structural and nonstructural members which materially affect the linear and nonlinear response of the structure to earthquake motions shall be considered in the analysis.

**1921.2.2.2** Rigid members assumed not to be a part of the lateral-force-resisting system may be used, provided their effect on the response of the system is considered and accommodated in the structural design. Consequences of failure of structural and nonstructural members which are not a part of the lateral-force-resisting system shall also be considered.

**1921.2.2.3** Structural members below base of structure required to transmit to the foundation forces resulting from earthquake effects shall also comply with the requirements of Section 1921.

**1921.2.2.4** All structural members assumed not to be part of the lateral-force-resisting system shall conform to Section 1921.7.

**1921.2.3 Strength-reduction factors.** Strength-reduction factors shall be as given in Section 1909.3.

**1921.2.4 Concrete in members resisting earthquake-induced forces.**

**1921.2.4.1** Compressive strength  $f'_c$  shall not be less than 3,000 psi (20.69 MPa).

*EXCEPTION: Footings of buildings three stories or less may have concrete with  $f'_c$  of not less than 2,500 psi (17.24 MPa).*

**1921.2.4.2** Compressive strength of lightweight-aggregate concrete used in design shall not exceed 4,000 psi (27.58 MPa). Lightweight aggregate concrete with higher design compressive strength may be used if demonstrated by experimental evidence that structural members made with that lightweight aggregate concrete provide strength and toughness equal to or exceeding those of comparable members made with normal-weight aggregate concrete of the same strength. *In no case shall the compressive strength of lightweight concrete used in design exceed 6,000 psi (41.37 MPa).*

**1921.2.5 Reinforcement in members resisting earthquake-induced forces.**

**1921.2.5.1** Reinforcement resisting earthquake-induced flexural and axial forces in frame members and in wall boundary elements shall comply with *low alloy* A 706. Billet steel A 615 Grades 40 and 60 reinforcement may be used in these members if (1) the actual yield strength based on mill tests does not exceed the specified yield strength by more than 18,000 psi (124.1 MPa) [retests shall not exceed this value by more than an additional 3,000 psi (20.69 MPa)], and (2) the ratio of the actual ultimate tensile stress to the actual tensile yield strength is not less than 1.25.

**1921.2.6 Welded splices and mechanically connected reinforcement.**

**1921.2.6.1** Reinforcement resisting earthquake-induced flexural or axial forces in frame members or in wall boundary members are permitted to be spliced using welded splices or mechanical connectors conforming to Section 1912.14.3.3 or 1912.14.3.4 provided not more than alternate bars in each layer of longitudinal reinforcement are spliced at a section and the center-to-center distance between splices of adjacent bars is 24 inches (610 mm) or more measured along the longitudinal axis of the member.

**1921.2.6.2** Welding of stirrups, ties, inserts or other similar elements to longitudinal reinforcement required by design shall not be permitted.

**1921.2.7 Load factors.** *For earthquake loading, the load factors given in Formulas (9-2) and (9-3) shall be modified to:*

$$U = 1.4 (D + L + E)$$

$$U = 0.9D \pm 1.4E$$

**1921.3 Flexural Members of Frames.**

**1921.3.1 Scope.** Requirements of this section apply to frame members (1) resisting earthquake-induced forces and (2) proportioned primarily to resist flexure. These frame members shall also satisfy the following conditions:

**1921.3.1.1** Factored axial compressive force on the member shall not exceed  $(A_g f'_c / 10)$ .

**1921.3.1.2** Clear span for the members shall not be less than four times its effective depth.

**1921.3.1.3** The width-to-depth ratio shall not be less than 0.3.

**1921.3.1.4** The width shall not be (1) less than 10 inches (254 mm) and (2) more than the width of the supporting member (measured on a plane perpendicular to the longitudinal axis of the flexural member) plus distances on each side of the supporting member not exceeding three fourths of the depth of the flexural member.

**1921.3.2 Longitudinal reinforcement.**

**1921.3.2.1** At any section of a flexural member and for the top as well as for bottom reinforcement, the amount of reinforcement shall not be less than  $(200 b_w d / f_y)$  (For SI:  $1.38 b_w d / f_y$ ) and the reinforcement ratio,  $\rho$ , shall not exceed 0.025. At least two bars shall be provided continuously at both top and bottom.

**1921.3.2.2** Positive-moment strength at joint face shall not be less than one half of the negative-moment strength provided at that face of the joint. Neither the negative nor the positive-moment strength at any section along member length shall be less than one fourth the maximum moment strength provided at face of either joint.

**1921.3.2.3** Lap splices of flexural reinforcement shall be permitted only if hoop or spiral reinforcement is provided over the lap length. Maximum spacing of the transverse reinforcement enclosing the lapped bars shall not exceed  $d/4$  or 4 inches (102 mm). Lap splices shall not be used (1) within the joints, (2) within a distance of twice the member depth from the face of joint, and (3) at locations where analysis indicates flexural yielding caused by inelastic lateral displacements of the frame.

**1921.3.2.4** Welded splices and mechanical connections shall conform to Section 1921.2.6.1.

**1921.3.3 Transverse reinforcement.**

**1921.3.3.1** Hoops shall be provided in the following regions of frame members:

1. Over a length equal to twice the member depth measured from the face of the supporting member toward midspan, at both ends of the flexural members.

2. Over lengths equal to twice the member depth on both sides of a section where flexural yielding may occur in connection with inelastic lateral displacements of the frame.

**1921.3.3.2** The first hoop shall be located not more than 2 inches (51 mm) from the face of a supporting member. Maximum spacing of the hoops shall not exceed (1)  $d/4$ , (2) eight times the diameter of the smallest longitudinal bars, (3) 24 times the diameter of the hoop bars, and (4) 12 inches (305 mm).

**1921.3.3.3** Where hoops are required, longitudinal bars on the perimeter shall have lateral support conforming to Section 1907.10.5.3.

**1921.3.3.4** Where hoops are not required, stirrups with 135-degree seismic hooks shall be spaced at no more than  $d/2$  throughout the length of the member.

**1921.3.3.5** Stirrups or ties required to resist shear shall be hoops over lengths of members as specified in Sections 1921.3.3, 1921.4.4 and 1921.5.2.

**1921.3.3.6** Hoops in flexural members may be made up of two pieces of reinforcement: a U-stirrup having 135-degree hooks with six-diameter [but not less than 3-inch (76 mm)] extensions anchored

in the confined core and a crosstie to make a closed hoop. Consecutive crossties engaging the same longitudinal bars shall have their 90-degree hooks at opposite sides of the flexural member. If the longitudinal reinforcing bars secured by the crossties are confined by a slab on only one side of the flexural frame member, the 90-degree hooks of the crossties shall all be placed on that side.

#### 1921.3.4 Shear-strength requirements.

**1921.3.4.1 Design forces.** The design shear forces  $V_e$  shall be determined from consideration of the static forces on the portion of the member between faces of the joint. It shall be assumed that moments of opposite sign corresponding to probable strength  $M_{pr}$  act at the joint faces and that the member is loaded with the tributary gravity load along its span.

**1921.3.4.2** For determining the required transverse reinforcement in frame members in which the earthquake-induced shear force represents one half or more of total design shear, the quantity  $V_e$  shall be assumed to be zero if the factored axial compressive force including earthquake effects is less than  $(A_g f'_c / 20)$ . *Earthquake-induced shear force is the shear induced by moments of opposite sign corresponding to probable strength acting at the joint faces, calculated in accordance with Section 1921.3.4.1.*

#### 1921.4 Frame Members Subjected to Bending and Axial Load.

**1921.4.1 Scope.** The requirements of Section 1921.4 apply to frame members (1) resisting earthquake-induced forces and (2) having a factored axial force exceeding  $A_g f'_c / 10$ . These frame members shall also satisfy the following conditions:

**1921.4.1.1** The shortest cross-sectional dimension, measured on a straight line passing through the geometric centroid, shall not be less than 12 inches (305 mm).

**1921.4.1.2** The ratio of the shortest cross-sectional dimension to the perpendicular dimension shall not be less than 0.4.

#### 1921.4.2 Minimum flexural strength of columns.

**1921.4.2.1** Flexural strength of any column proportioned to resist a factored axial compressive force exceeding  $A_g f'_c / 10$  shall satisfy Section 1921.4.2.2 or 1921.4.2.3.

Lateral strength and stiffness of columns not satisfying Section 1921.4.2.2 shall be ignored in determining the calculated strength and stiffness of the structure but shall conform to Section 1921.7.

**1921.4.2.2** The flexural strengths of the columns shall satisfy Formula (21-1).

$$\Sigma M_e \geq (6/5) \Sigma M_g \quad (21-1)$$

#### WHERE:

$\Sigma M_e$  = sum of moments, at the center of the joint, corresponding to the design flexural strength of the columns framing into that joint. Column flexural strength shall be calculated for the factored axial force, consistent with the direction of the lateral forces considered, resulting in the lowest flexural strength.

$\Sigma M_g$  = sum of moments, at the center of the joint, corresponding to the design flexural strengths of the girders framing into that joint.

Flexural strengths shall be summed such that the column moments oppose the beam moments. Formula (21-1) shall be satisfied for beam moments acting in both directions in the vertical plane of the frame considered.

**1921.4.2.3** If Section 1921.4.2.2 is not satisfied at a joint, columns supporting reactions from that joint shall be provided with transverse reinforcement as specified in Section 1921.4.4 over their full height.

**1921.4.3 Longitudinal reinforcement.**

**1921.4.3.1** The reinforcement ratio  $\rho_g$  shall not be less than 0.01 and shall not exceed 0.06.

**1921.4.3.2** Welded splices and mechanical connections shall conform to Section 1921.2.6.1. Lap splices are permitted only within the center half of the member length and shall be proportioned as tension splices.

**1921.4.4 Transverse reinforcement.**

**1921.4.4.1** Transverse reinforcement as specified below shall be provided unless a larger amount is required by Section 1921.4.5.

1. The volumetric ratio of spiral or circular hoop reinforcement,  $\rho_s$ , shall not be less than that indicated by Formula (21-2).

$$\rho_s = 0.12 f'_c / f_{yh} \quad (21-2)$$

and shall not be less than that required by Formula (10-5).

2. The total cross-sectional area of rectangular hoop reinforcement shall not be less than that given by Formulas (21-3) and (21-4).

$$A_{sh} = 0.3 (sh_c f'_c / f_{yh}) [(A_g / A_{ch}) - 1] \quad (21-3)$$

$$A_{sh} = 0.09 (sh_c f'_c / f_{yh}) \quad (21-4)$$

3. Transverse reinforcement shall be provided by either single or overlapping hoops. Crossties of the same bar size and spacing as the hoops may be used. Each end of the crosstie shall engage a peripheral longitudinal reinforcing bar. Consecutive crossties shall be alternated end for end along the longitudinal reinforcement.

4. If the design strength of member core satisfies the requirement of the specified loading combinations including earthquake effect, Formulas (21-3) and (10-5) need not be satisfied.

5. *Any area of a column which extends more than 4 inches (102 mm) beyond the confined core shall have minimum reinforcement as required for nonseismic columns as specified in Section 1921.7.*

6. *Where the calculated point of contraflexure is not within the middle half of the member clear height, provide transverse reinforcement as specified in Sections 1921.4.4.1, Items 1 through 3, over the full height of the member.*

**1921.4.4.2** Transverse reinforcement shall be spaced at distances not exceeding (i) one-quarter minimum member distance and (ii) 4 inches (102 mm). *Additional ties which engage at least four vertical column bars shall be provided around anchor bolts which are set in the top of a column. Such ties shall be within 5 inches (127 mm) of the top of the column and shall consist of two No. 4 or three No. 3 bars.*

**1921.4.4.3** Crossties or legs of overlapping hoops shall not be spaced more than 14 inches (356 mm) on center in the direction perpendicular to the longitudinal axis of the structural member.

**1921.4.4.4** Transverse reinforcement in amount specified in Sections 1921.4.4.1 through 1921.4.4.3 shall be provided over a length  $l_o$  from each joint face and on both sides of any section where flexural yielding may occur in connection with inelastic lateral displacements of the frame. The length  $l_o$  shall not be less than (1) the depth of the member at the joint face or at the section where flexural yielding may occur, (2) one sixth of the clear span of the member, and (3) 18 inches (457 mm).

**1921.4.4.5** Columns supporting reactions from discontinued stiff members, such as walls, shall be provided with transverse reinforcement as specified in Sections 1921.4.4.1 through 1921.4.4.3 over

their full height beneath the level at which the discontinuity occurs if the factored axial compressive force in these members, including earthquake effect, exceeds  $A_g f'_c / 10$ . Transverse reinforcement as specified in Sections 1921.4.4.1 through 1921.4.4.3 shall extend into the discontinued member for at least the development length of the largest longitudinal reinforcement in the column in accordance with Section 1921.5.4. If the lower end of the column terminates on a wall, transverse reinforcement as specified in Sections 1921.4.4.1 through 1921.4.4.3 shall extend into the wall for at least the development length of the largest longitudinal reinforcement in the column at the point of termination. If the column terminates on a footing or mat, transverse reinforcement as specified in Sections 1921.4.4.1 through 1921.4.4.3 shall extend at least 12 inches (305 mm) into the footing or mat.

**1921.4.4.6** Where transverse reinforcement as specified in Sections 1921.4.4.1 through 1921.4.4.3 is not provided throughout the full length of the column, the remainder of the column length shall contain spiral or hoop reinforcement with center-to-center spacing not exceeding the smaller of six times the diameter of the longitudinal column bars or 6 inches (152 mm).

*1921.4.4.7 At any section where the design strength,  $\phi P_n$ , of the column is less than the sum of the shears  $V_e$  computed in accordance with Sections 1921.3.4.1 and 1921.4.5.1 for all the beams framing into the column above the level under consideration, transverse reinforcement as specified in Sections 1921.4.4.1 through 1921.4.4.3 shall be provided. For beams framing into opposite sides of the column, the moment components may be assumed to be of opposite sign. For the determination of the design strength,  $\phi P_n$ , of the column, these moments may be assumed to result from the deformation of the frame in any one principal axis.*

#### **1921.4.5 Shear strength requirements.**

**1921.4.5.1 Design forces.** The design shear force  $V_e$  shall be determined from the consideration of the maximum forces that can be generated at the faces of the joints at each end of the member. These joint forces shall be determined using the maximum probable moment strengths,  $M_{pr}$ , of the member associated with the range of factored axial loads on the member. The member shear need not exceed those determined from joint strengths based on the probable moment strength,  $M_{pr}$ , of the transverse members framing in the joint. In no case shall  $V_e$  be less than the factored shear determined by analysis of the structure.

**1921.4.5.2** For determining the required transverse reinforcement in frame members in which the earthquake-induced shear force represents one half or more of total design shear, the quantity  $V_e$  shall be assumed to be zero if the factored axial compressive force including earthquake effects is less than  $(A_g f'_c / 20)$ . *Earthquake-induced shear force is the shear induced by moments of opposite sign corresponding to probable strength acting at the joint faces, calculated in accordance with Sections 1921.3.4.1 and 1921.4.5.1.*

#### **1921.5 Joints of Frames.**

##### **1921.5.1 General requirements.**

**1921.5.1.1** Forces in longitudinal beam reinforcement at the joint face shall be determined by assuming that the stress in the flexural tensile reinforcement is  $1.25 f_y$ .

**1921.5.1.2** Strength of joint shall be governed by the appropriate strength-reduction factors specified in Section 1909.3.

**1921.5.1.3** Beam longitudinal reinforcement terminated in a column shall be extended to the far face of the confined column core and anchored in tension according to Section 1921.5.4, and in compression according to Section 1912.

**1921.5.1.4** Where longitudinal beam reinforcement extends through a beam-column joint, the column dimension parallel to the beam reinforcement shall not be less than 20 times the diameter of the largest longitudinal bar for normal-weight concrete. For lightweight concrete, the dimension shall not be less than 26 times the bar diameter.

**1921.5.2 Transverse reinforcement.**

**1921.5.2.1** Transverse hoop reinforcement as specified in Section 1921.4.4 shall be provided within the joint, unless the joint is confined by structural members as specified in Section 1921.5.2.2.

**1921.5.2.2** Within the depth of the shallowest framing member, transverse reinforcement equal to at least one half the amount required by Section 1921.4.4.1 shall be provided where members frame into all four sides of the joint and where each member width is at least three fourths the column width. At these locations, the spacing specified in Section 1921.4.4.2 may be increased to 6 inches (152 mm).

**1921.5.2.3** Transverse reinforcement as required by Section 1921.4.4 shall be provided through the joint to provide confinement for longitudinal beam reinforcement outside the column core if such confinement is not provided by a beam framing into the joint.

**1921.5.3 Shear strength.**

**1921.5.3.1** The nominal shear strength of the joint shall not be taken greater than the forces specified below for normal-weight aggregate concrete.

For joints confined on all four faces . . . . .  $20 \sqrt{f'_c} A_j$  (For SI:  $1.66 \sqrt{f'_c} A_j$ )

For joints confined on three faces or on two opposite faces . . .  $15 \sqrt{f'_c} A_j$  (For SI:  $1.25 \sqrt{f'_c} A_j$ )

For others . . . . .  $12 \sqrt{f'_c} A_j$  (For SI:  $1.00 \sqrt{f'_c} A_j$ )

A member that frames into a face is considered to provide confinement to the joint if at least three fourths of the face of the joint is covered by the framing member. A joint is considered to be confined if such confining members frame into all faces of the joint.

**1921.5.3.2** For lightweight aggregate concrete, the nominal shear strength of the joint shall not exceed three fourths of the limits for normal-weight aggregate concrete.

**1921.5.4 Development length for reinforcement in tension.**

**1921.5.4.1** The development length,  $l_{dh}$ , for a bar with a standard 90-degree hook in normal-weight aggregate concrete shall not be less than  $8d_b$ , 6 inches (152 mm), and the length required by Formula (21-5).

$$l_{dh} = f_y d_b / 65 \sqrt{f'_c} \quad (21-5)$$

For SI: 
$$l_{dh} = f_y d_b / 5.4 \sqrt{f'_c}$$

for bar sizes No. 3 through No. 11.

For lightweight aggregate concrete, the development length for a bar with a standard 90-degree hook shall not be less than  $10d_b$ , 7.5 inches (191 mm), and 1.25 times that required by Formula (21-5).

The 90-degree hook shall be located within the confined core of a column or of a boundary member.

**1921.5.4.2** For bar sizes No. 3 through No. 11, the development length,  $l_d$ , for a straight bar shall not be less than (1) 2.5 times the length required by Section 1921.5.4.1 if the depth of the concrete cast in one lift beneath the bar does not exceed 12 inches (305 mm), and (2) 3.5 times the length required by Section 1921.5.4.1 if the depth of the concrete cast in one lift beneath the bar exceeds 12 inches (305 mm).

**1921.5.4.3** Straight bars terminated at a joint shall pass through the confined core of a column or of a boundary member. Any portion of the straight embedment length not within the confined core shall be increased by a factor of 1.6.

**1921.6 Shear Walls, Diaphragms and Trusses.**

**1921.6.1 Scope.** The requirements of this section apply to *shear* walls and trusses serving as parts of the earthquake-force-resisting systems as well as to diaphragms, struts, ties, chords and collector members which transmit forces induced by earthquake.

**1921.6.2 Reinforcement.**

**1921.6.2.1** The reinforcement ratio,  $\rho_v$ , for *shear* walls shall not be less than 0.0025 along the longitudinal and transverse axes. If the design shear force does not exceed  $A_{cv} \sqrt{f'_c}$  (For SI:  $0.08A_{cv} \sqrt{f'_c}$ ), the minimum reinforcement for *shear* walls shall be in conformance with Section 1914.3. The minimum reinforcement ratio for structural diaphragms shall be in conformance with Section 1907.12. Reinforcement spacing each way in *shear* walls and diaphragms shall not exceed 18 inches (457 mm). Reinforcement provided for shear strength shall be continuous and shall be distributed across the shear plane.

**1921.6.2.2** At least two curtains of reinforcement shall be used in a wall if the in-plane factored shear force assigned to the wall exceeds  $2A_{cv} \sqrt{f'_c}$  (For SI:  $0.166A_{cv} \sqrt{f'_c}$ ).

*When  $V_u$  in the plane of the wall exceeds  $A_{cv} \sqrt{f'_c}$  (For SI:  $0.08A_{cv} \sqrt{f'_c}$ ), horizontal reinforcement terminating at the edges of shear walls shall have a standard hook engaging the edge reinforcement, or the edge reinforcement shall be enclosed in "U" stirrups having the same size and spacing as, and spliced to, the horizontal reinforcement.*

**1921.6.2.3** Structural-truss elements, struts, ties and collector elements with compressive stresses exceeding  $0.2f'_c$  shall have special transverse reinforcement, as specified in Section 1921.4.4, over the total length of the element. The special transverse reinforcement may be discontinued at a section where the calculated compressive stress is less than  $0.15f'_c$ . Stresses shall be calculated for the factored forces using a linearly elastic model and gross-section properties of the elements considered.

**1921.6.2.4** All continuous reinforcement in *shear* walls, diaphragms, trusses, struts, ties, chords and collector elements shall be anchored or spliced in accordance with the provisions for reinforcement in tension as specified in Section 1921.5.4. *Where necessary to avoid congestion, splices in horizontal reinforcement shall be staggered. Splices in two curtains, where used, shall not occur in the same location.*

**1921.6.3 Design forces.** The design shear force  $V_u$  shall be obtained from the lateral load analysis in accordance with the factored loads and combinations specified in Section 1909.2 and as modified in Section 1921.2.7.

**1921.6.4 Shear strength.**

**1921.6.4.1** Nominal shear strength of *shear* walls and diaphragms shall be determined using either Section 1921.6.4.2 or 1921.6.4.3.

**1921.6.4.2** Nominal shear strength,  $V_n$ , of *shear* walls and diaphragms shall be assumed not to exceed the shear force calculated from

$$V_n = A_{cv} (2\sqrt{f'_c} + \rho_n f_y) \quad (21-6)$$

For SI: 
$$V_n = A_{cv} (0.166\sqrt{f'_c} + \rho_n f_y)$$

**1921.6.4.3** For walls (diaphragms) and wall (diaphragm) segments having a ratio of ( $h_w/l_w$ ) less than 2.0, nominal shear strength of wall (diaphragm) shall be determined from Formula (21-7)

$$V_n = A_{cv} (\alpha_c \sqrt{f'_c} + \rho_n f_y) \quad (21-7)$$

For SI: 
$$V_n = A_{cv} (0.08\alpha_c \sqrt{f'_c} + \rho_n f_y)$$

Where the coefficient  $\alpha_c$  varies linearly from 3.0 for  $h_w/l_w = 1.5$  to 2.0 for  $h_w/l_w = 2.0$ .

**1921.6.4.4** In Section 1921.6.4.3 above, the value of ratio ( $h_w/l_w$ ) used for determining  $V_n$  for segments of a wall or diaphragm shall be the largest of the ratios for the entire wall (diaphragm) and the segment of wall (diaphragm) considered.

**1921.6.4.5** Walls (diaphragms) shall have distributed shear reinforcement providing resistance in two orthogonal directions in the plane of the wall (diaphragm). If the ratio ( $h_w/l_w$ ) does not exceed 2.0, reinforcement ratio  $\rho_v$  shall not be less than reinforcement ratio  $\rho_n$ .

**1921.6.4.6** Nominal shear strength of all wall piers sharing a common lateral force shall not be assumed to exceed  $8A_{cv}\sqrt{f'_c}$  (For SI:  $0.66A_{cv}\sqrt{f'_c}$ ) where  $A_{cv}$  is the total cross-sectional area and the nominal shear strength of any one of the individual wall piers shall not be assumed to exceed  $10A_{cp}\sqrt{f'_c}$  (For SI:  $0.83A_{cp}\sqrt{f'_c}$ ) where  $A_{cp}$  represents the cross-sectional area of the pier considered.

**1921.6.4.7** Nominal shear strength of horizontal wall segments shall not be assumed to exceed  $10A_{cp}\sqrt{f'_c}$  (For SI:  $0.83A_{cp}\sqrt{f'_c}$ ) where  $A_{cp}$  represents the cross-sectional area of a horizontal wall segment.

**1921.6.5 Design of shear walls for flexural and axial loads.**

**1921.6.5.1** Shear walls and portions of shear walls subject to combined flexural and axial loads shall be designed in accordance with Sections 1910.2 and 1910.3, except Section 1910.3.6 and the nonlinear strain requirements of Section 1910.2.2 do not apply. The strength-reduction factor  $\phi$  shall be in accordance with Section 1909.3.

**1921.6.5.2** The effective flange widths to be used in the design of I-, L-, C- or T-shaped sections shall not be assumed to extend further from the face of the web than (1) one half the distance to an adjacent shear wall web, or (2) 10 percent of the total wall height.

**1921.6.5.3** Walls and portions of walls with  $P_u > 0.35P_o$  shall not be considered to contribute to the calculated strength of the structure for resisting earthquake-induced forces. Such walls shall conform to the requirements of Section 1631.2.4.

**1921.6.5.4** Shear wall boundary zone detail requirements as defined in Section 1921.6.5.6 need not be provided in shear walls or portions of shear walls meeting the following conditions:

1.  $P_u \leq 0.10A_g f'_c$  for geometrically symmetrical wall sections  
 $P_u \leq 0.05A_g f'_c$  for geometrically unsymmetrical wall sections

and either

2.  $\frac{M_u}{V_u l_w} \leq 1.0$

or

3.  $V_u \leq 3l_w h \sqrt{f'_c}$  (For SI:  $V_u \leq 0.25l_w h \sqrt{f'_c}$ )

Shear walls and portions of shear walls not meeting the conditions of Section 1921.6.5.4 and having  $P_u < 0.35P_o$  shall have boundary zones at each end a distance varying linearly from  $0.25 l_w$  to  $0.15 l_w$  for  $P_u$  varying from  $0.35 P_o$  to  $0.15 P_o$ . The boundary zone shall have minimum length of  $0.15 l_w$  and shall be detailed in accordance with Section 1921.6.5.6.

**1921.6.5.5** Alternatively, the requirements for boundary zones in shear walls or portions of shear walls not meeting the conditions of Section 1921.6.5.4 may be based on determination of the compressive strain levels at edges when the wall or portion of wall is subjected to displacement levels

resulting from the ground motions specified in Section 1629.2 using cracked section properties and considering the response modification effects of possible nonlinear behavior of the building.

Boundary zone detail requirements as defined in Section 1921.6.5.6 shall be provided over those portions of the wall where compressive strains exceed 0.003. In no instance shall designs be permitted in which compressive strains exceed  $\epsilon_{max}$ .

**WHERE:**

$$\epsilon_{max} = \frac{3R_w}{8} (0.004) \leq 0.015 \quad (21-8)$$

1. Using the displacement of Section 1921.6.5.5, determine the curvature of the wall cross section at each location of potential flexural yielding assuming the possible nonlinear response of the wall and its elements. Using a strain compatibility analysis of the wall cross section, determine the compressive strains resulting from these curvatures.

2. For shear walls in which the flexural limit state response is governed by yielding at the base of the wall, compressive strains at wall edges may be approximated as follows:

Determine the total curvature demand ( $\phi_t$ ) as given in Formula (21-9):

$$\phi_t = \frac{\Delta_i}{(h_w - l_p/2)l_p} + \phi_y \quad (21-9)$$

**WHERE:**

$c'_u$  = neutral axis depth at  $P'_u$  and  $M'_n$ .

$l_p$  = height of the plastic hinge above critical section and which shall be established on the basis of substantiated test data or may be alternatively taken as  $0.5l_w$ .

$\Delta_E$  = elastic design displacement at the top of the wall using gross section properties and code-specified seismic forces.

$\Delta_i$  = inelastic deflection at top of wall.

$$= \Delta_t - \Delta_y$$

$\Delta_t$  = total deflection at the top of the wall equal to  $3R_w/8$  times the elastic design displacement using cracked section properties, or may be taken as  $2(3R_w/8)\Delta_E$ .

$\Delta_y$  = displacement at top of wall corresponding to extreme fiber compressive strain of 0.003 at critical section, or may be taken as  $(M'_n/M_E)\Delta_E$ , where  $M_E$  equals moment at critical section when top of wall is displaced  $\Delta_E$  and  $M'_n$  is nominal flexural strength of critical section at  $P'_u = 1.2D + 0.5L + E$ .

$$\phi_y = \frac{0.003}{c'_u}$$

The compressive strains may be assumed to vary linearly over the depth  $c'_u$  and have maximum value equal to the product of  $c'_u$  and  $\phi_t$ .

**1921.6.5.6 Shear wall boundary zone detail requirements.** When required by Section 1921.6.5.1 through 1921.6.5.5, boundary zones shall meet the following:

1. Dimensional requirements.

1.1 All portions of the boundary zones shall have a thickness of  $l_w/10$  or greater.

1.2 Boundary zones shall extend vertically a distance equal to the development length of the largest vertical bar within the boundary zone above the elevation where the requirements of Section 1921.6.5.4 or 1921.6.5.5 are met.

Extensions below the base of the boundary zone shall conform to Section 1921.4.4.6.

**EXCEPTION:** The boundary zone reinforcement need not extend above the base of the boundary zone a distance greater than the larger of  $l_w$  or  $M_u/4V_u$ .

1.3 Boundary zones as determined by the requirements of Section 1921.6.5.5 shall have a minimum length of  $0.1l_w$  at each end of the wall or portion of wall.

1.4 In I-, L-, C- or T-shaped sections, the boundary zone at each end shall include the effective flange width and shall extend at least 12 inches (305 mm) into the web.

2. Confinement reinforcement.

2.1 All vertical reinforcement within the boundary zone shall be confined by hoops or cross ties producing an area of steel not less than:

$$A_{sh} = 0.09s_h f'_c / f_{yh} \quad (21-10)$$

2.2 Hoops and cross ties shall have a vertical spacing not greater than the smaller of 6 inches (152 mm) or 6 diameters of the largest vertical bar within the boundary zone.

2.3 The ratio of the length to the width of the hoops shall not exceed 3. All adjacent hoops shall be overlapping.

2.4 Cross ties or legs of overlapping hoops shall not be spaced further apart than 12 inches (305 mm) along the wall.

2.5 Alternate vertical bars shall be confined by the corner of a hoop or cross tie.

3. Horizontal reinforcement.

3.1 All horizontal reinforcement terminating within a boundary zone shall be anchored in accordance with Section 1921.6.2.

3.2 Horizontal reinforcement shall not be lap spliced within the boundary zone.

4. Vertical reinforcement.

4.1 Vertical reinforcement shall be provided to satisfy all tension and compression requirements.

4.2 Area of reinforcement shall not be less than 0.005 times the area of boundary zone or less than two No. 5 bars at each edge of boundary zone.

4.3 Lap splices of vertical reinforcement within the boundary zone shall be confined by hoops or cross ties. Spacing of hoops and cross ties confining lap-spliced reinforcement shall not exceed 4 inches (102 mm).

**1921.6.6 Boundaries of structural diaphragms.**

**1921.6.6.1** Boundary elements of structural diaphragms shall be proportioned to resist the sum of the factored axial force acting in the plane of the diaphragm and the force obtained from dividing the factored moment at the section by the distance between the edges of the diaphragm at that section.

**1921.6.6.2** Splices of tensile reinforcement in the boundaries and collector elements of all diaphragms shall develop the yield strength of the reinforcement. Welded splices and mechanical connections shall conform to Section 1921.2.6.1.

**1921.6.7 Construction joints.**

**1921.6.7.1** All construction joints in walls and diaphragms shall conform to Section 1906.4, and contact surfaces shall be roughened as specified in Section 1911.7.9.

**1921.6.8 Discontinuous walls.** Columns supporting discontinuous walls shall be reinforced in accordance with Section 1921.4.4.5.

**1921.6.9 Coupling beams.** Horizontal members with clear span-to-effective-depth ratio ( $l_n/d$ ) of less than 4 and factored shear force  $V_u$  exceeding  $4\sqrt{f'_c} b_w d$  (For SI:  $0.33\sqrt{f'_c} b_w d$ ) and which interconnect shear walls shall be provided with special shear reinforcement as follows:

1. Symmetrical diagonal shear reinforcement shall be provided to extend diagonally across the full length of the member and located within the confined concrete core as specified in Section 1921.3.3.

2. The required area of one leg of the diagonal reinforcement  $A_{vd}$  shall not be less than

$$A_{vd} = \frac{V_u}{2f_y \sin \alpha}$$

**WHERE:**

$f_y$  = yield stress of diagonal reinforcement.

$V_u$  = factored shear force.

$\alpha$  = angle between diagonal reinforcement and longitudinal axis of the member.

3. Flexural strength contribution by the diagonal reinforcement shall be included in the flexural capacity calculation of the member.

**1921.6.10 Floor topping.** A cast-in-place topping on a precast floor system may serve as the diaphragm, provided the cast-in-place topping acting alone is proportioned and detailed to resist the design forces.

**1921.6.11 Minimum thickness of diaphragms.** Diaphragms used to resist prescribed lateral forces shall not be less than 2 inches (51 mm) thick. Topping slabs placed over precast floor and roof elements shall not be less than 2½ inches (64 mm) thick.

**1921.6.12 Wall piers.**

**1921.6.12.1** Wall piers not designed as part of a special moment-resisting frame shall have transverse reinforcement designed to satisfy the requirements in Section 1921.6.12.2.

**EXCEPTIONS:** 1. Wall piers that satisfy Section 1921.7.

2. Wall piers along a wall line within a story where other shear wall segments provide lateral support to the wall piers, and such segments have a total stiffness of at least six times the sum of the stiffnesses of all the wall piers.

**1921.6.12.2** Transverse reinforcement shall be designed to resist the shear forces determined from Sections 1921.4.5.1 and 1921.3.4.2. When the axial compressive force, including earthquake effects, is less than  $A_g f'_c/20$ , transverse reinforcement in wall piers may have standard hooks at each end in lieu of hoops. Spacing of transverse reinforcement shall not exceed 6 inches (152 mm). Transverse reinforcement shall be extended beyond the pier clear height for at least the development length of the largest longitudinal reinforcement in the wall pier.

**1921.6.12.3** Wall segments with horizontal length-to-thickness ratio less than 2½ shall be designed as columns.

**1921.7 Frame Members Not Part of the Lateral-force-resisting System.**

**1921.7.1** Frame members which are not designated to be a part of the lateral-force-resisting system shall be detailed according to Section 1921.7.1.1 or 1921.7.1.2 depending on the magnitude of moments induced in those members when subjected to 3 ( $R_w/8$ ) times the displacements resulting from the specified lateral forces in conformance with the requirements of Section 1631.2.4.

**1921.7.1.1** When the induced moment exceeds the design moment strength of the frame member, members with factored axial compressive forces not exceeding ( $A_g f'_c/10$ ) shall satisfy Sections 1921.3.2.1 and 1921.3.4.1 and members with factored axial compressive forces exceeding ( $A_g f'_c/10$ ) shall satisfy Sections 1921.4.4, 1921.4.5.1 and 1921.5.2.1.

**1921.7.1.2** When the induced moment does not exceed the design moment strength of the frame members, the member shall satisfy Section 1921.3.2.1.

**1921.7.2** All frame members with factored axial compressive forces exceeding ( $A_g f'_c/10$ ) shall satisfy the following special requirements unless they comply with Section 1921.4.4.

**1921.7.2.1** Ties shall have hooks not less than 135 degrees with extensions not less than six tie-bar diameters or 3 inches (76 mm). Crossties, as defined in Section 1921.1, are allowed.

**1921.7.2.2** The maximum tie spacing shall be  $s_o$  over a length  $l_o$  measured from the joint face. The spacing  $s_o$  shall not be more than the smallest of (1) eight diameters of the smallest longitudinal bar enclosed, (2) 24 tie-bar diameters, and (3) one half the least cross-sectional dimension of the column. The length  $l_o$  shall not be less than the largest of (1) one sixth of the clear height of the column, (2) the maximum cross-sectional dimension of the column, and (3) 18 inches (457 mm).

**1921.7.2.3** The first tie shall be within a distance equal to  $0.5s_o$  from the face of the joint.

**1921.7.2.4** The tie spacing shall not exceed  $2s_o$  in any part of the column.

**1921.7.3 Ties at anchor bolts.** *Additional ties which engage at least four vertical column bars shall be provided around anchor bolts which are set in the top of a column. Such ties shall be within 5 inches (127 mm) of the top of the column and shall consist of two No. 4 or three No. 3 bars.*

### **1921.8 Requirements for Frames in Seismic Zone 2.**

**1921.8.1** *In Seismic Zone 2, structural frames proportioned to resist forces induced by earthquake motions shall satisfy the requirements of Section 1921.8 in addition to those of Sections 1901 through 1918.*

**1921.8.2** Reinforcement details in a frame member shall satisfy Section 1921.8.4 if the factored compressive axial load for the member does not exceed  $(A_g f'_c/10)$ . If the factored compressive axial load is larger, frame reinforcement details shall satisfy Section 1921.8.5 unless the member has spiral reinforcement according to Formula (10-5). If a two-way slab system without beams is treated as part of a frame-resisting earthquake effect, reinforcement details in any span resisting moments caused by lateral force shall satisfy Section 1921.8.6.

**1921.8.3** Design shear strength of beams, columns and two-way slabs resisting earthquake effect shall not be less than either (1) the sum of the shear associated with development of nominal moment strengths of the member at each restrained end of the clear span and the shear calculated for gravity loads, or (2) the maximum shear obtained from design load combinations which include earthquake effect  $E$ , with  $E$  assumed to be twice that prescribed in Section 1624.

#### **1921.8.4 Beams.**

**1921.8.4.1** The positive-moment strength at the face of the joint shall not be less than one third the negative-moment strength provided at that face of the joint. Neither the negative- nor the positive-moment strength at any section along the length of the member shall be less than one fifth the maximum moment strength provided at the face of either joint.

**1921.8.4.2** At both ends of the member, stirrups shall be provided over lengths equal to twice the member depth measured from the face of the supporting member toward midspan. The first stirrup shall be located at not more than 2 inches (51 mm) from the face of the supporting member. Maximum stirrup spacing shall not exceed (1)  $d/4$ , (2) eight times the diameter of the smallest longitudinal bar enclosed, (3) 24 times the diameter of the stirrup bar, and (4) 12 inches (305 mm).

**1921.8.4.3** Stirrups shall be placed at not more than  $d/2$  throughout the length of the member.

#### **1921.8.5 Columns.**

**1921.8.5.1** Maximum tie spacing shall not exceed  $s_o$  over a length  $l_o$  measured from the joint face. Spacing  $s_o$  shall not exceed (1) eight times the diameter of the smallest longitudinal bar enclosed, (2) 24 times the diameter of the tie bar, (3) one half of the smallest cross-sectional dimension of the frame member, and (4) 12 inches (305 mm). Length  $l_o$  shall not be less than (1) one sixth of the clear span of the member, (2) maximum cross-sectional dimension of the member, and (3) 18 inches (457 mm).

**1921.8.5.2** The first tie shall be located at not more than  $s_o/2$  from the joint face.

**1921.8.5.3** Joint reinforcement shall conform to Section 1911.11.2.

**1921.8.5.4** Tie spacing shall not exceed twice the spacings  $s_o$ .

**1921.8.5.5** *In addition to the column lateral ties required in Section 1907.1.3, Item 3, additional ties which engage at least four vertical column bars shall be provided around anchor bolts which are set in the top of a column. Such ties shall be within 5 inches (127 mm) of the top of the column and shall consist of two No. 4 or three No. 3 bars.*

**1921.8.6 Two-way slabs without beams.**

**1921.8.6.1** Factored slab moment at support related to earthquake effect shall be determined for load combinations defined by Formulas (9-2) and (9-3). All reinforcement provided to resist  $M_s$ , the portion of slab moment balanced by support moment, shall be placed within the column strip defined in Section 1913.2.1.

**1921.8.6.2** The fraction, defined by Formula (13-1), of moment  $M_s$  shall be resisted by reinforcement placed within the effective width specified in Section 1913.3.2.

**1921.8.6.3** Not less than one half of the reinforcement in the column strip at support shall be placed within the effective slab width specified in Section 1913.3.2.

**1921.8.6.4** Not less than one fourth of the top reinforcement at the support in the column strip shall be continuous throughout the span.

**1921.8.6.5** Continuous bottom reinforcement in the column strip shall not be less than one third of the top reinforcement at the support in the column strip.

**1921.8.6.6** Not less than one half of all bottom reinforcement at midspan shall be continuous and shall develop its yield strength at face of support as defined in Section 1913.6.2.5.

**1921.8.6.7** At discontinuous edges of the slab, all top and bottom reinforcement at support shall be developed at the face of support as defined in Section 1913.6.2.5.

**1921.9 Inspection.** *For moment frames resisting design seismic load in structures within Seismic Zones 3 and 4, a specially qualified inspector who will provide reports to the person responsible for the structural design shall provide continuous inspection of the placement of the reinforcement and concrete and shall submit a certificate indicating compliance with the plans and specifications.*

**SECTION 1922 — SHOTCRETE**

**1922.1 General.** *Shotcrete shall be defined as mortar or concrete pneumatically projected at high velocity onto a surface. Except as specified in this section, shotcrete shall conform to the regulations of this chapter for plain concrete or reinforced concrete.*

**1922.2 Proportions and Materials.** *Shotcrete proportions shall be selected that allow suitable placement procedures using the delivery equipment selected and shall result in finished in-place hardened shotcrete meeting the strength requirements of this code.*

**1922.3 Aggregate.** *Coarse aggregate, if used, shall not exceed  $3/4$  inch (19 mm).*

**1922.4 Reinforcement.** *The maximum size of reinforcement shall be No. 5 bars unless it can be demonstrated by preconstruction tests that adequate encasement of larger bars can be achieved. When No. 5 or smaller bars are used, there shall be a minimum clearance between parallel reinforcement bars of  $2\frac{1}{2}$  inches (64 mm). When bars larger than No. 5 are permitted, there shall be a minimum clearance between parallel bars equal to six diameters of the bars used. When two curtains of steel are provided, the curtain nearest the nozzle shall have a minimum spacing equal to 12 bar diameters and the remaining curtain shall have a minimum spacing of six bar diameters.*

**EXCEPTION:** Subject to the approval of the building official, reduced clearances may be used where it can be demonstrated by preconstruction tests that adequate encasement of the bars used in the design can be achieved.

Lap splices in reinforcing bars shall be by the noncontact lap splice method with at least 2 inches (51 mm) clearance between bars. The building official may permit the use of contact lap splices when necessary for the support of the reinforcing provided it can be demonstrated by means of pre-construction testing, that adequate encasement of the bars at the splice can be achieved, and provided that the splices are placed so that a line through the center of the two spliced bars is perpendicular to the surface of the shotcrete work.

Shotcrete shall not be applied to spirally tied columns.

**1922.5 Preconstruction Tests.** When required by the building official a test panel shall be shot, cured, cored or sawn, examined and tested prior to commencement of the project. The sample panel shall be representative of the project and simulate job conditions as closely as possible. The panel thickness and reinforcing shall reproduce the thickest and most congested area specified in the structural design. It shall be shot at the same angle, using the same nozzleman and with the same concrete mix design that will be used on the project.

**1922.6 Rebound.** Any rebound or accumulated loose aggregate shall be removed from the surfaces to be covered prior to placing the initial or any succeeding layers of shotcrete. Rebound shall not be reused as aggregate.

**1922.7 Joints.** Except where permitted herein, unfinished work shall not be allowed to stand for more than 30 minutes unless all edges are sloped to a thin edge. Before placing additional material adjacent to previously applied work, sloping and square edges shall be cleaned and wetted.

**1922.8 Damage.** In-place shotcrete which exhibits sags or sloughs, segregation, honeycombing, sand pockets or other obvious defects shall be removed and replaced. Shotcrete above sags and sloughs shall be removed and replaced while still plastic.

**1922.9 Curing.** During the curing periods specified herein, shotcrete shall be maintained above 40° F. (4.4° C.) and in moist condition. In initial curing, shotcrete shall be kept continuously moist for 24 hours after placement is complete. Final curing shall continue for seven days after shotcreting, for three days if high-early-strength cement is used, or until the specified strength is obtained. Final curing shall consist of a fog spray or an approved moisture-retaining cover or membrane. In sections of a depth in excess of 12 inches (305 mm), final curing shall be the same as that for initial curing.

**1922.10 Strength Test.** Strength test for shotcrete shall be made by an approved agency on specimens which are representative of work and which have been water soaked for at least 24 hours prior to testing. When the maximum size aggregate is larger than  $\frac{3}{8}$  inch (9.5 mm), specimens shall consist of not less than three 3-inch-diameter (76 mm) cores or 3-inch (76 mm) cubes. When the maximum size aggregate is  $\frac{3}{8}$  inch (9.5 mm) or smaller, specimens shall consist of not less than three 2-inch-diameter (51 mm) cores or 2-inch (51 mm) cubes. Specimens shall be taken in accordance with one of the following:

1. From the in-place work: taken at least once each shift or less than one for each 50 cubic yards (38.2 m<sup>3</sup>) of shotcrete; or
2. From test panels: made not less than once each shift or not less than one for each 50 cubic yards (38.2 m<sup>3</sup>) of shotcrete placed. When the maximum size aggregate is larger than  $\frac{3}{8}$  inch (9.5 mm), the test panels shall have a minimum dimension of 18 inches by 18 inches (457 mm by 457 mm). When the maximum size aggregate is  $\frac{3}{8}$  inch (9.5 mm) or smaller, the test panels shall have a minimum dimension of 12 inches by 12 inches (305 mm by 305 mm). Panels shall be gunned in the same position as the work, during the course of the work and by nozzlemen doing the work. The condition under which the panels are cured shall be the same as the work.

The average of three cores from a single panel shall be equal to or exceed  $0.85 f'_c$  with no single core less than  $0.75 f'_c$ . The average of three cubes taken from a single panel must equal or exceed  $f'_c$  with no individual cube less than  $0.88 f'_c$ . To check testing accuracy, locations represented by erratic core strengths may be retested.

**1922.11 Inspections.**

**1922.11.1 During placement.** When shotcrete is used for structural members, a special inspector is required by Section 1701.5, Item 12. The special inspector shall provide continuous inspection of the placement of the reinforcement and shotcreting and shall submit a statement indicating compliance with the plans and specifications.

**1922.11.2 Visual examination for structural soundness of in-place shotcrete.** Completed shotcrete work shall be checked visually for reinforcing bar embedment, voids, rock pockets, sand streaks and similar deficiencies by examining a minimum of three 3-inch (76 mm) cores taken from three areas chosen by the design engineer which represent the worst congestion of reinforcing bars occurring in the project. Extra reinforcing bars may be added to noncongested areas and cores may be taken from these areas. The cores shall be examined by the special inspector and a report submitted to the building official prior to final approval of the shotcrete.

**EXCEPTION:** Shotcrete work fully supported on earth, minor repairs, and when, in the opinion of the building official, no special hazard exists.

**1922.12 Equipment.** The equipment used in preconstruction testing shall be the same equipment used in the work requiring such testing, unless substitute equipment is approved by the building official.

**SECTION 1923 — PLAIN CONCRETE****1923.1 General.**

**1923.1.1 Scope.** This section provides minimum requirements for design and construction of plain concrete for both cast-in-place and precast members.

**EXCEPTION:** The design is not required when the minimum foundation for stud walls is in accordance with Table 18-I-D.

**1923.1.2 Limitations.** Use of plain concrete shall be limited to (1) members that are continuously supported by soil or supported by other structural members capable of providing continuous vertical support; (2) members for which arch action provides compression under all conditions of loading; or (3) cast-in-place concrete piles or piers, except in Seismic Zones 2, 3 and 4, that have adequate lateral support for stability and where calculated compression occurs on the entire cross section under all conditions of loading.

The design requirements of Section 1923 are not intended to apply to nonstructural members of plain concrete, such as soil-supported slabs, unless such slabs transmit vertical loads from other parts of the structure to the soil.

Plain concrete for compression members, other than arches, walls, and cast-in-place piles and piers permitted in the first paragraph of this subsection, shall be limited to pedestals in accordance with Section 1923.9.4.

Plain concrete shall not be used in Seismic Zones 2, 3 or 4, except where specifically permitted by Section 1923.10.3.

**1923.2 Definitions.** For the purpose of this section, certain terms are defined as follows:

**CONTROL JOINT** is a construction joint or partial joint (minimum 25 percent reduction of member thickness) used for the purpose of reducing buildup of internal stresses caused by restraint to movements due to creep, shrinkage or temperature effects.

**PLAIN CONCRETE** is concrete that is either unreinforced or contains less reinforcement than the minimum amount specified in this code for reinforced concrete.

**1923.3 Materials.** Specification for testing and materials shall be in accordance with Section 1903. Plain concrete, other than fill, shall have a specified compressive strength,  $f'_c$ , of not less than 2,500 psi (17.24 MPa).

**1923.4 Joints.** Unless reinforcement is used to control temperature and shrinkage stresses, plain concrete construction shall be provided with control joints to divide members into flexurally discontinuous elements. When control joints are used, the size of each element shall be limited to control buildup of excessive internal stresses within each element caused by restraint to movement from creep, shrinkage and temperature effects.

**1923.5 Notations.**

- $A_1$  = loaded area.  
 $A_2$  = maximum area of the portion of the supported surface that is geometrically similar to and concentric with the loaded area.  
 $B_c$  = ratio of long side to short side of concentrated load or reaction area.  
 $b$  = width of member, inches (mm).  
 $f'_c$  = specified compressive strength of concrete, pounds per square inch (MPa).  
 $\sqrt{f'_c}$  = square root of specified compressive strength of concrete, pounds per square inch (MPa).  
 $h$  = overall thickness of member, inches (mm). See Section 1923.8.5.  
 $k$  = effective length factor. See Section 1923.9.2.2.  
 $l_c$  = vertical distance between supports, inches (mm).  
 $V_u$  = factored shear force at section.  
 $v_u$  = shear stress due to factored shear force at section.  
 $\phi$  = strength-reduction factor. See Section 1923.7.

**1923.6 Design Method.** Plain concrete members shall be designed for adequate strength in accordance with provisions of this code, using load factors and permissible stresses:

Factored loads and forces shall be in such combinations as specified in Section 1909.2.

Stresses due to factored loads and forces shall not exceed permissible stresses given in Section 1923.7.

**1923.7 Permissible Stresses.** Maximum fiber stresses in plain concrete due to factored loads and moments shall not exceed the following:

1. Flexure:

Extreme fiber stress in compression .....  $\phi f'_c$

Extreme fiber stress in tension (normal weight only) .....  $5\phi\sqrt{f'_c}$  (For SI:  $0.42\phi\sqrt{f'_c}$ )

2. Axial compression

$$0.60f'_c \left[ 1 - \left( \frac{klc}{32h} \right)^2 \right]$$

3. Shear (normal-weight concrete only)

Beam action .....  $2\phi\sqrt{f'_c}$  (For SI:  $0.166\phi\sqrt{f'_c}$ )

Two-way action .....  $\left( 2 + \frac{4\phi}{B_c} \right) \sqrt{f'_c}$  [For SI:  $\left( 0.166 + \frac{0.33\phi}{B_c} \right) \sqrt{f'_c}$ ]

but not greater than .....  $4\phi\sqrt{f'_c}$  (For SI:  $0.33\phi\sqrt{f'_c}$ )

4. Bearing on loaded area .....  $0.85\phi f'_c$

When the supporting surface is wider on all sides than the loaded area, permissible bearing stress on the loaded area is permitted to be increased by  $\sqrt{A_2/A_1}$ , but not more than 2. When the supporting surface is sloped or stepped,  $A_2$  is permitted to be taken as the area of the lower base of the largest frustum of a right pyramid or cone contained wholly within the support and having for its upper base the loaded area, and having side slopes of 1 vertical to 2 horizontal.

Strength-reduction factor  $\phi$  for flexure, compression, shear and bearing on plain concrete shall be 0.65.

### 1923.8 Design.

**1923.8.1 General.** Strength design of plain concrete members for flexure and axial loads shall be based on a linear stress-strain relationship in both tension and compression.

**1923.8.2 Tensile.** Tensile strength of concrete is permitted to be considered in design of plain concrete members when provisions of Section 1923.3 have been followed such that stresses will not exceed permissible stresses as prescribed in Section 1923.7.

**1923.8.3 Reinforcement.** No strength shall be assigned to reinforcement present in plain concrete members.

**1923.8.4 Continuity.** Tension shall not be transmitted through outside edges, construction joints or control joints of an individual plain concrete element. No flexural continuity due to tension shall be assumed between adjacent plain concrete elements.

**1923.8.5 Cross section considered.** In computing stresses due to flexure, combined flexure and axial load, and shear, the entire cross section of a member shall be considered in design. For concrete cast against soil, overall thickness  $h$  shall be taken as 2 inches (51 mm) less than actual thickness.

**1923.8.6 Proportioning.** Members subject to combined flexure and axial load shall be proportioned such that the sum of the ratios of all calculated to permissible stresses in compression given in Section 1923.7, Items 1 and 2, shall be less than or equal to one. Tensile stress resulting from combined flexure and axial load shall not exceed permissible stress in tension given in Section 1923.7, Item 1.

**1923.8.7 Shear.** Shear stress for rectangular sections shall be computed by

$$v_u = \frac{3V_u}{2bh} \quad (23-1)$$

Maximum shear stress  $v_u$  shall be computed at a distance  $h$  from the face of the support, and sections located at a lesser distance are permitted to be designed for the same shear.

Shear stress  $v_u$  shall not exceed permissible shear stress for beam action given in Section 1923.7, Item 3.

### 1923.9 Plain Concrete Members.

#### 1923.9.1 Notations.

- $A_g$  = gross area of section, square inches ( $\text{mm}^2$ ).
- $b_o$  = perimeter of critical section for shear in footing, inches (mm).
- $f'_c$  = specified compressive strength of concrete, pounds per square inch (MPa).
- $h$  = overall thickness of member, inches (mm). See Section 1923.8.5.
- $k$  = effective length factor.
- $l_c$  = vertical distance between supports, inches (mm).
- $P_{nw}$  = nominal axial load strength of wall designed by Section 1923.9.2.2.
- $V_u$  = factored shear force at section.
- $v_u$  = shear stress due to factored shear force at section.
- $\phi$  = strength-reduction factor. See Section 1923.7.

#### 1923.9.2 Walls.

**1923.9.2.1 General.** Except for walls meeting the limitations of Section 1923.9.2.2, plain concrete walls shall be designed for vertical, lateral and other loads in accordance with Section

1923.8.6. The wall shall be designed for an eccentricity corresponding to the maximum moment that can accompany the axial load, but not less than  $0.10h$ .

**1923.9.2.2 Axial strength.** Plain concrete walls of solid rectangular cross section where the resultant of all factored loads is located within the middle third of the overall wall thickness are permitted to be designed in accordance with the following procedure.

Design axial load strength  $\phi P_{nw}$  of a plain concrete wall satisfying limitations of the paragraph above shall be computed by:

$$\phi P_{nw} = 0.45\phi f'_c A_g \left[ 1 - \left( \frac{kl_c}{32h} \right)^2 \right] \quad (23-2)$$

Where the effective length factor  $k$  shall be:

For walls braced top and bottom against lateral translation and

1. Restrained against rotation at one or both ends (top and/or bottom) . . . . . 0.8
2. Unrestrained against rotation at both ends . . . . . 1.0

Design of shear shall be in accordance with Section 1923.8.7.

**1923.9.2.3 Limitations.** Whether designed in accordance with Section 1923.8.6 or the provisions of Section 1923.9.2.2, plain concrete walls shall comply with all the limitations set forth in this subsection.

Unless demonstrated by a detailed analysis, the horizontal length of wall to be considered effective for each vertical concentrated load shall not exceed the smaller of the center-to-center distance between loads, or the width of bearing plus four times the wall thickness.

Thickness of bearing walls shall not be less than  $1/24$  the unsupported height or length, whichever is less, and not less than  $5\frac{1}{2}$  inches (140 mm).

Thickness of exterior basement walls and foundation walls shall not be less than  $7\frac{1}{2}$  inches (191 mm).

Walls shall be braced against lateral translation.

Not less than two No. 5 bars shall be provided around all window and door openings. Such bars shall extend at least 24 inches (610 mm) beyond the corners of openings.

### 1923.9.3 Footings.

**1923.9.3.1 General.** Plain concrete footings shall be designed for the combination of loads specified in Section 1909.2 and as provided for in this subsection.

The base area of footing shall be determined from the combination of loads specified in Section 1909.2 using unfactored loads and moments transmitted by the footing to the soil utilizing the permissible soil pressure and as provided for in this subsection.

Plain concrete shall not be used for footings on piles.

Overall thickness of plain concrete footings shall not be less than 6 inches (152 mm).

**1923.9.3.2 Moment in plain concrete footings.** Maximum factored moment shall be computed at critical sections located as follows:

1. At face of column, pedestal or wall for a footing supporting a concrete column, pedestal or wall.
2. Halfway between middle and edge of wall for a footing supporting a masonry wall.
3. Halfway between face of column and edge of steel base plate for a footing supporting a column with steel base plate.

**1923.9.3.3 Shear in plain concrete footings.** Maximum factored shear shall be computed in accordance with the provisions of this subsection, with location of critical section measured from face of column, pedestal or wall for a footing supporting a column, pedestal or wall. For a footing supporting a column with a steel base plate, the critical section shall be measured from the location defined in Section 1923.9.3.2.

Shear strength of plain concrete footings in the vicinity of concentrated loads or reactions shall be governed by the more severe of the following two conditions:

Beam action for footing, with a critical section extending in a plane across the entire width and located at a distance  $h$  from the face of a concentrated load or reaction area. For this condition, the footing shall be designed in accordance with the provisions of this subsection.

Two-way action for footing, with a critical section perpendicular to plane of footing and located so that its perimeter  $b_o$  is a minimum, but need not approach closer than  $h/2$  to the perimeter of a concentrated load or reaction area. For this condition, the footing shall be designed in accordance with Section 1923.9.3.2, Items 2 and 3.

Shear stress  $v_u$  shall be computed by

$$v_u = \frac{3V_u}{2b_o h} \quad (23-3)$$

Where  $V_u$  and  $b_o$  shall be taken at the critical section defined in this subsection, and  $h$  is the overall thickness of footing as prescribed in Section 1923.8.5.

Shear stress  $v_u$  shall not exceed permissible shear stress for two-way action given in Section 1923.7, Item 3.

**1923.9.3.4 Shape.** Circular or regular polygon-shaped concrete columns or pedestals are permitted to be treated as square members with the same area for location of critical sections for moment and shear.

**1923.9.3.5 Bearing stress.** Bearing stress on concrete at contact surface between supporting and supported member shall not exceed permissible bearing stress for either surface as given in Section 1923.7, Item 4.

**1923.9.4 Pedestals.** Plain concrete pedestals shall be designed for vertical, lateral and other loads to which they are subjected.

The ratio of unsupported height to average least lateral dimension of plain concrete pedestals shall not exceed 3.

The maximum compressive stress in plain concrete pedestals shall not exceed the permissible bearing stress given in Section 1923.7, Item 4.

**1923.9.5 Precast members.** Design of precast plain concrete members shall consider all loading conditions from initial fabrication to completion of the structure, including form removal, storage, transportation and erection.

Limitations cited in Section 1923.1.2 apply for precast members of structural plain concrete, not only to the final condition, but also during fabrication, transportation and erection.

Precast members shall be connected securely to transfer all lateral forces into a structural system capable of resisting such forces. Precast members shall be adequately braced and supported during erection to ensure proper alignment and structural integrity until permanent connections are completed.

## **1923.10 Seismic Requirements for Plain Concrete.**

**1923.10.1 General.** The design and construction of plain concrete components that resist seismic forces shall conform to the requirements of Section 1923, except as modified by this subsection.

**1923.10.2 Seismic Zones 0 and 1.** Structural plain concrete members located in Seismic Zones 0 and 1 shall be designed in accordance with the provisions of Sections 1923.1 through 1923.9.

**1923.10.3 Seismic Zones 2, 3 and 4.** Structural plain concrete members are not permitted in buildings located in Seismic Zones 2, 3 and 4.

**EXCEPTIONS:** 1. Footings for buildings of Group R, Division 3 or Group U, Division 1 Occupancy constructed in accordance with Table 18-I-D.

2. Nonstructural slabs supported directly on the ground or by approved structural systems.

## SECTION 1924 — MINIMUM SLAB THICKNESS

The minimum thickness of concrete floor slabs supported directly on the ground shall not be less than 3<sup>1</sup>/<sub>2</sub> inches (89 mm).

## SECTION 1925 — ANCHORAGE TO CONCRETE

**1925.1 Service Load Design.** Bolts and headed stud anchors shall be solidly cast in concrete and the service load shear and tension shall not exceed the values set forth in Table 19-E.

For combined tension and shear:

$$(P_s/P_t)^{5/3} + (V_s/V_t)^{5/3} \leq 1$$

**WHERE:**

$P_s$  = applied service tension load.

$P_t$  = Table 19-E service tension load.

$V_s$  = applied service shear load.

$V_t$  = Table 19-E service shear load.

**1925.2 Strength Design.** The factored loads on embedded anchor bolts and headed studs shall not exceed the design strengths determined by Section 1925.3.

In addition to the load factors in Section 1909.2, a multiplier of 2 shall be used if special inspection is not provided, or of 1.3 if it is provided. When anchors are embedded in the tension zone of a member, the load factors in Section 1909.2 shall have a multiplier of 3 if special inspection is not provided, or of 2 if it is provided.

### 1925.3 Strength of Anchors.

**1925.3.1 General.** The strength of headed bolts and headed studs solidly cast in concrete shall be taken as the average of 10 tests approved by the building official for each concrete strength and anchor size or calculated in accordance with Sections 1925.3.2 through 1925.3.4. The bearing area of headed anchors shall be at least one and one-half times the shank area.

**1925.3.2 Design strength in tension.** The design strength of anchors in tension shall be the minimum of  $P_{ss}$  or  $\phi P_c$  where:

$$P_{ss} = 0.9A_b f'_s$$

and for an anchor group where the distance between anchors is less than twice their embedment length

$$\phi P_c = \phi \lambda (2.8A_s + 4A_t) \sqrt{f'_c}$$

For SI:

$$\phi P_c = 0.08 \phi \lambda (2.8A_s + 4A_t) \sqrt{f'_c}$$

or for a single anchor or anchor group where the distance between anchors is equal or greater than twice their embedment length

$$\phi P_c = \phi \lambda (2.8A_s) \sqrt{f'_c}$$

For SI:

$$\phi P_c = 0.08 \phi \lambda (2.8A_s) \sqrt{f'_c}$$

**WHERE:**

- $A_b$  = area [in square inches ( $\text{mm}^2$ )] of bolt or stud. Must be used with the corresponding steel properties to determine the weakest part of the assembly in tension.
- $A_s$  = the sloping area [in square inches ( $\text{mm}^2$ )] of an assumed failure surface. For a single anchor or anchor group where the distance between anchors is equal to or greater than twice their embedment length, the surface is assumed to be that of a truncated cone radiating at a 45-degree slope from the bearing edge of the anchor to the surface. For an anchor group where the distance between anchors is less than twice their embedment length, the failure surface is assumed to be that of a truncated pyramid radiating at a 45-degree slope from the bearing edge of the anchor group to the surface. In addition, for thin sections with anchor groups, the failure surface shall be assumed to follow the extension of this slope through to the far side rather than truncated, and the failure mode resulting in the lower value of  $\phi P_c$  shall control.
- $A_t$  = the area [in square inches ( $\text{mm}^2$ )] of the flat bottom of the truncated pyramid of an assumed concrete failure surface. Where anchors in a group are closer than twice their embedment length, the failure surface pyramid is assumed to truncate at the anchor bearing edge rather than form separate cones.
- $f'_c$  = specified compression strength of concrete, which shall not be taken as greater than 6,000 psi (41.37 MPa) for design.
- $f'_s$  = specified tensile strength [in psi (MPa)] of the bolt or stud. For A 307 bolts or A 108 studs,  $f'_s$  may be assumed to be 60,000 psi (413.7 MPa).
- $P_u$  = required tensile strength due to factored loads, pounds (N).
- $V_u$  = required shear strength due to factored loads, pounds (N).
- $\lambda$  = 1 for normal-weight concrete, 0.75 for "all lightweight" concrete, and 0.85 for "sand-lightweight" concrete.
- $\phi$  = strength-reduction factor  
= 0.65.

**EXCEPTION:** Where the anchor is attached to or hooked around reinforcing steel or otherwise terminated so as to effectively transfer forces to reinforcing steel that is designed to distribute forces and avert sudden local failure,  $\phi$  may be taken as 0.85.

Where edge distance is less than embedment length, reduce  $\phi P_c$  proportionately. For multiple edge distances less than the embedment length, use multiple reductions.

**1925.3.3 Design strength in shear.** The design strength of anchors in shear shall be the minimum of  $V_{ss}$  or  $\phi V_c$  where:

$$V_{ss} = 0.75A_b f'_s$$

and where loaded toward an edge equal to or greater than 10 diameters away,

$$\phi V_c = \phi 800A_b \lambda \sqrt{f'_c}$$

For SI:

$$\phi V_c = 66.4 \phi A_b \lambda \sqrt{f'_c}$$

or where loaded toward an edge less than 10 diameters away,

$$\phi V_c = \phi 2\pi d_e^2 \lambda \sqrt{f'_c}$$

For SI:

$$\phi V_c = 0.166 \phi \pi d_e^2 \lambda \sqrt{f'_c}$$

where  $d_e$  equals the edge distance from the anchor axis to the free edge.

For groups of anchors, the concrete design shear strength shall be taken as the smallest of:

1. The design strength of the weakest anchor times the number of anchors,
2. The design strength of the row of anchors nearest the free edge in the direction of shear times the number of rows or
3. The design strength of the row farthest from the free edge in the direction of shear.

For shear loading toward an edge less than 10 diameters away, or tension or shear not toward an edge less than four diameters away, reinforcing sufficient to carry the load shall be provided to prevent failure of the concrete in tension. In no case shall the edge distance be less than one third the above.

**1925.3.4 Combined tension and shear.** When tension and shear act simultaneously, all of the following shall be met:

$$\frac{1}{\phi} \left( \frac{P_u}{P_c} \right) \leq 1 \qquad \frac{1}{\phi} \left( \frac{V_u}{V_c} \right) \leq 1$$

$$\frac{1}{\phi} \left[ \left( \frac{P_u}{P_c} \right)^2 + \left( \frac{V_u}{V_c} \right)^2 \right] \leq 1 \qquad \left( \frac{P_u}{P_{ss}} \right)^2 + \left( \frac{V_u}{V_{ss}} \right)^2 \leq 1$$

## SECTION 1926 — ALTERNATE DESIGN METHOD

**1926.0 Notation.** The following symbols and notations apply only to the provisions of this section:

- $A_g$  = gross area of section, square inches (mm<sup>2</sup>).
- $A_1$  = loaded area.
- $A_2$  = maximum area of the portion of the supporting surface that is geometrically similar to and concentric with the loaded area.
- $A_v$  = area of shear reinforcement within a distance  $s$ , square inches (mm<sup>2</sup>).
- $b$  = width of compression face of member, inches (mm).
- $b_o$  = perimeter of critical section for slabs and footings, inches (mm).
- $b_w$  = web width, or diameter of circular section, inches (mm).
- $d$  = distance from extreme compression fiber to centroid of tension reinforcement, inches (mm).
- $E_c$  = modulus of elasticity of concrete, psi (MPa). See Section 1908.5.1.
- $E_s$  = modulus of elasticity of reinforcement, psi (MPa). See Section 1908.5.2.
- $f'_c$  = specified compressive strength of concrete, psi (MPa). See Section 1905.
- $\sqrt{f'_c}$  = square root of specified compressive strength of concrete, psi (MPa).
- $f_{ct}$  = average splitting tensile strength of lightweight aggregate concrete, psi (MPa). See Section 1905.1.4.
- $f_s$  = permissible tensile stress in reinforcement, psi (MPa).
- $f_y$  = specified yield strength of reinforcement, psi (MPa).
- $M$  = design moment.
- $N$  = design axial load normal to cross section occurring simultaneously with  $V$ ; to be taken as positive for compression, negative for tension and to include effects of tension due to creep and shrinkage.

- $n$  = modular ratio of elasticity.  
=  $E_s/E_c$ .
- $s$  = spacing of shear reinforcement in direction parallel to longitudinal reinforcement, inches (mm).
- $V$  = design shear force at section.
- $v$  = design shear stress.
- $v_c$  = permissible shear stress carried by concrete, psi (MPa).
- $v_h$  = permissible horizontal shear stress, psi (MPa).
- $\alpha$  = angle between inclined stirrups and longitudinal axis of member.
- $\beta_c$  = ratio of long side to short side of concentrated load or reaction area.
- $\rho$  = ratio of tension reinforcement.  
=  $A_s/bd$ .
- $\phi$  = strength-reduction factor. See Section 1926.2.1.

**1926.1 Scope.**

**1926.1.1** Nonprestressed reinforced concrete members may be designed using service loads (without load factors) and permissible service load stresses in accordance with provisions of this section.

**1926.1.2** For design of members not covered by this section, appropriate provisions of this code shall apply.

**1926.1.3** All applicable provisions of this code for nonprestressed concrete, except Section 1908.4, shall apply to members designed by the alternate design method.

**1926.1.4** Flexural members shall meet requirements for deflection control in Section 1909.5 and requirements of Sections 1910.4 through 1910.7 of this code.

**1926.2 General.**

**1926.2.1** Load factors and strength-reduction factors  $\phi$  shall be taken as unity for members designed by the alternate design method.

**1926.2.2** Members may be proportioned for 75 percent of capacities required by other parts of the section when considering wind or earthquake forces combined with other loads, provided the resulting section is not less than that required for the combination of dead and live load.

**1926.2.3** When dead load reduces effects of other loads, members shall be designed for 85 percent of dead load in combination with the other loads.

**1926.3 Permissible Service Load Stresses.**

**1926.3.1** Stresses in concrete shall not exceed the following:

1. Flexure.  
Extreme fiber stress in compression .....  $0.45 f'_c$
2. Shear.†  
Beams and one-way slabs and footings:  
Shear carried by concrete,  $v_c$  .....  $1.1 \sqrt{f'_c}$  (For **SI**:  $0.09 \sqrt{f'_c}$ )  
Maximum shear carried by  
concrete plus shear reinforcement .....  $v_c + 4.4 \sqrt{f'_c}$  (For **SI**:  $v_c + 0.37 \sqrt{f'_c}$ )  
Joists.\*  
Shear carried by concrete,  $v_c$  .....  $1.2 \sqrt{f'_c}$  (For **SI**:  $0.10 \sqrt{f'_c}$ )

†For more detailed calculation of shear stress carried by concrete  $v_c$  and shear values for lightweight aggregate concrete, see Section 1926.7.4.

\*Designed in accordance with Section 1908.11 of this code.

Two-way slabs and footings:

Shear carried by concrete,  $v_c \ddagger$  . . . . .  $(1 + 2/\beta_c)\sqrt{f'_c}$  [For SI:  $(1 + 2/\beta_c)0.08\sqrt{f'_c}$ ]  
 . . . . . but not greater than  $2\sqrt{f'_c}$  (For SI:  $0.166\sqrt{f'_c}$ )

3. Bearing on loaded area\*\* . . . . .  $0.3 f'_c$

‡If shear reinforcement is provided, see Sections 1926.7.7.4 and 1926.7.7.5.

\*\*When the supporting surface is wider on all sides than the loaded area, permissible bearing stress on the loaded area may be increased by  $\sqrt{A_2/A_1}$  but not more than 2. When the supporting surface is sloped or stepped,  $A_2$  may be taken as the area of the lower base of the largest frustum of a right pyramid or cone contained wholly within the support and having for its upper base the loaded area and having side slopes of 1 vertical to 2 horizontal.

**1926.3.2** Tensile stress in reinforcement  $f_s$  shall not exceed the following:

1. Grade 40 or Grade 50 reinforcement . . . . . 20,000 psi (137.9 MPa)
2. Grade 60 reinforcement or greater and welded wire fabric (smoothed or deformed) . . . . . 24,000 psi (165.5 MPa)
3. For flexural reinforcement,  $3/8$  inch (9.5 mm) or less in diameter, in one-way slabs of not more than 12-foot (3658 mm) span, but not greater than 30,000 psi (206.8 MPa) . . . . .  $0.50 f_y$

**1926.4 Development and Splices of Reinforcement.**

**1926.4.1** Development and splices of reinforcement shall be as required in Section 1912.

**1926.4.2** In satisfying requirements of Section 1912.11.3,  $M_n$  shall be taken as computed moment capacity assuming all positive moment tension reinforcement at the section to be stressed to the permissible tensile stress  $f_s$ , and  $V_u$  shall be taken as unfactored shear force at the section.

**1926.5 Flexure.** For investigation of stresses at service loads, straight-line theory (for flexure) shall be used with the following assumptions:

**1926.5.1** Strains vary linearly as the distance from the neutral axis, except for deep flexural members with overall depth-span ratios greater than 2:5 for continuous spans and 4:5 for simple spans, a nonlinear distribution of strain shall be considered. (See Section 1910.7.)

**1926.5.2** Stress-strain relationship of concrete is a straight line under service loads within permissible service load stresses.

**1926.5.3** In reinforced concrete members, concrete resists no tension.

**1926.5.4** Modular ratio,  $n = E_s/E_c$ , may be taken as the nearest whole number (but not less than 6). Except in calculations for deflections, value of  $n$  for lightweight concrete shall be assumed to be the same as for normal-weight concrete of the same strength.

**1926.5.5** In doubly reinforced flexural members, an effective modular ratio of  $2 E_s/E_c$  shall be used to transform compression reinforcement for stress computations. Compressive stress in such reinforcement shall not exceed permissible tensile stress.

**1926.6 Compression Members with or without Flexure.**

**1926.6.1** Combined flexure and axial load capacity of compression members shall be taken as 40 percent of that computed in accordance with provisions in Section 1910.

**1926.6.2** Slenderness effects shall be included according to requirements of Sections 1910.10 and 1910.11. In Formulas (10-7) and (10-8), the term  $P_u$  shall be replaced by 2.5 times the design axial load, and  $\phi$  shall be taken equal to 1.0.

**1926.6.3** Walls shall be designed in accordance with Section 1914 with flexure and axial load capacities taken as 40 percent of that computed using Section 1914. In Formula (14-1),  $\phi$  shall be taken equal to 1.0.

**1926.7 Shear and Torsion.****1926.7.1** Design shear stress  $v$  shall be computed by:

$$v = \frac{V}{b_w d} \quad (26-1)$$

where  $V$  is design shear force at section considered.**1926.7.2** When the reaction, in direction of applied shear, introduces compression into the end regions of a member, sections located less than a distance  $d$  from face of support may be designed for the same shear  $v$  as that computed at a distance  $d$ .**1926.7.3** Whenever applicable, effects of torsion, in accordance with provisions of Section 1911, shall be added. Shear and torsional moment strengths provided by concrete and limiting maximum strengths for torsion shall be taken as 55 percent of the values given in Section 1911.**1926.7.4 Shear stress carried by concrete.****1926.7.4.1** For members subject to shear and flexure only, shear stress carried by concrete  $v_c$  shall not exceed  $1.1\sqrt{f'_c}$  (For **SI**:  $0.09\sqrt{f'_c}$ ) unless a more detailed calculation is made in accordance with Section 1926.7.4.4.**1926.7.4.2** For members subject to axial compression, shear stress carried by concrete  $v_c$  shall not exceed  $1.1\sqrt{f'_c}$  (For **SI**:  $0.09\sqrt{f'_c}$ ) unless a more detailed calculation is made in accordance with Section 1926.7.4.5.**1926.7.4.3** For members subject to significant axial tension, shear reinforcement shall be designed to carry total shear, unless a more detailed calculation is made using

$$v_c = 1.1 \left( 1 + 0.004 \frac{N}{A_g} \right) \sqrt{f'_c} \quad (26-2)$$

$$\text{For SI:} \quad v_c = 0.09 \left( 1 + 0.004 \frac{N}{A_g} \right) \sqrt{f'_c}$$

where  $N$  is negative for tension. Quantity  $N/A_g$  shall be expressed in psi (MPa).**1926.7.4.4** For members subject to shear and flexure only,  $v_c$  may be computed by

$$v_c = \sqrt{f'_c} + 1,300 \rho_w \frac{Vd}{M} \quad (26-3)$$

$$\text{For SI:} \quad v_c = 0.083 \sqrt{f'_c} + 9 \rho_w \frac{Vd}{M}$$

but  $v_c$  shall not exceed  $1.9\sqrt{f'_c}$  (For **SI**:  $0.16\sqrt{f'_c}$ ). Quantity  $Vd/M$  shall not be taken greater than 1.0 where  $M$  is design moment occurring simultaneously with  $V$  at section considered.**1926.7.4.5** For members subject to axial compression,  $v_c$  may be computed by

$$v_c = 1.1 \left( 1 + 0.0006 \frac{N}{A_g} \right) \sqrt{f'_c} \quad (26-4)$$

$$\text{For SI:} \quad v_c = 0.09 \left( 1 + 0.0006 \frac{N}{A_g} \right) \sqrt{f'_c}$$

Quantity  $N/A_g$  shall be expressed in psi (MPa).**1926.7.4.6** Shear stresses carried by concrete  $v_c$  apply to normal-weight concrete. When light-weight aggregate concrete is used, one of the following modifications shall apply:

1. When  $f_{ct}$  is specified and concrete is proportioned in accordance with Section 1904.2,  $f_{ct}/6.7$  (For SI:  $1.8 f_{ct}$ ) shall be substituted for  $\sqrt{f'_c}$ , but the value of  $f_{ct}/6.7$  (For SI:  $1.8 f_{ct}$ ) shall not exceed  $\sqrt{f'_c}$ .

2. When  $f_{ct}$  is not specified, the value of  $\sqrt{f'_c}$  (For SI:  $0.083 \sqrt{f'_c}$ ) shall be multiplied by 0.75 for all-lightweight concrete and by 0.85 for sand-lightweight concrete. Linear interpolation may be applied when partial sand replacement is used.

**1926.7.4.7** In determining shear stress carried by concrete  $v_c$ , whenever applicable, effects of axial tension due to creep and shrinkage in restrained members shall be considered and effects of inclined flexural compression in variable depth members may be included.

**1926.7.5 Shear stress carried by shear reinforcement.**

**1926.7.5.1 Types of shear reinforcement.** Shear reinforcement may consist of:

1. Stirrups perpendicular to axis of member.
2. Welded wire fabric with wires located perpendicular to axis of member making an angle of 45 degrees or more with longitudinal tension reinforcement.
3. Longitudinal reinforcement with bent portion making an angle of 30 degrees or more with longitudinal tension reinforcement.
4. Combinations of stirrups and bent longitudinal reinforcement.
5. Spirals.

**1926.7.5.2** Design yield strength of shear reinforcement shall not exceed 60,000 psi (413.7 MPa).

**1926.7.5.3** Stirrups and other bars or wires used as shear reinforcement shall extend to a distance  $d$  from extreme compression fiber and shall be anchored at both ends according to Section 1912.13 to develop design yield strength of reinforcement.

**1926.7.5.4 Spacing limits for shear reinforcement.**

**1926.7.5.4.1** Spacing of shear reinforcement placed perpendicular to axis of member shall not exceed  $d/2$  or 24 inches (610 mm).

**1926.7.5.4.2** Inclined stirrups and bent longitudinal reinforcement shall be so spaced that every 45-degree line, extending toward the reaction from middepth of member  $d/2$  to longitudinal tension reinforcement, shall be crossed by at least one line of shear reinforcement.

**1926.7.5.4.3** When  $(v - v_c)$  exceeds  $2\sqrt{f'_c}$  (For SI:  $0.166\sqrt{f'_c}$ ) maximum spacing given by this subsection shall be reduced by one half.

**1926.7.5.5 Minimum shear reinforcement.**

**1926.7.5.5.1** A minimum area of shear reinforcement shall be provided in all reinforced concrete flexural members where design shear stress  $v$  is greater than one half the permissible shear stress  $v_c$  carried by concrete, except the following:

1. Slab and footings.
2. Concrete joist construction defined by Section 1908.11 of this code.
3. Beams with total depth not greater than 10 inches (254 mm), two and one-half times thickness of flange or one half the width of web, whichever is greater.

**1926.7.5.5.2** Minimum shear reinforcement requirements of this subsection may be waived if shown by test that required ultimate flexural and shear strength can be developed when shear reinforcement is omitted.

**1926.7.5.5.3** Where shear reinforcement is required by this subsection or by analysis, minimum area of shear reinforcement shall be computed by

$$A_v = 50 \frac{b_w s}{f_y} \quad (26-5)$$

For SI: 
$$A_v = 0.34 \frac{b_w s}{f_y}$$

where  $b_w$  and  $s$  are in inches (mm).

**1926.7.5.6 Design of shear reinforcement.**

**1926.7.5.6.1** Where design shear stress  $v$  exceeds shear stress carried by concrete  $v_c$ , shear reinforcement shall be provided in accordance with this subsection.

**1926.7.5.6.2** When shear reinforcement perpendicular to axis of member is used,

$$A_v = \frac{(v - v_c)b_w s}{f_s} \quad (26-6)$$

**1926.7.5.6.3** When inclined stirrups are used as shear reinforcement,

$$A_v = \frac{(v - v_c)b_w s}{f_s (\sin \alpha + \cos \alpha)} \quad (26-7)$$

**1926.7.5.6.4** When shear reinforcement consists of a single bar or a single group of parallel bars, all bent up at the same distance from the support,

$$A_v = \frac{(v - v_c)b_w d}{f_s \sin \alpha} \quad (26-8)$$

where  $(v - v_c)$  shall not exceed  $1.6 \sqrt{f'_c}$  (For SI:  $0.13 \sqrt{f'_c}$ ).

**1926.7.5.6.5** When shear reinforcement consists of a series of parallel bent-up bars or groups of parallel bent-up bars at different distances from the support, required area shall be computed by Formula (26-7).

**1926.7.5.6.6** Only the center three fourths of the inclined portion of any longitudinal bent bar shall be considered effective for shear reinforcement.

**1926.7.5.6.7** When more than one type of shear reinforcement is used to reinforce the same portion of a member, required area shall be computed as the sum of the various types separately. In such computations,  $v_c$  shall be included only once.

**1926.7.5.6.8** Value of  $(v - v_c)$  shall not exceed  $4.4 \sqrt{f'_c}$  (For SI:  $0.37 \sqrt{f'_c}$ ).

**1926.7.6 Shear friction.** Where it is appropriate to consider shear transfer across a given plane such as an existing or potential crack, an interface between dissimilar materials, or an interface between two concretes cast at different times, shear friction provisions of Section 1911.7 may be applied with limiting maximum stress for shear taken as 55 percent of that given in Section 1911.7.5. Permissible stress in shear friction reinforcement shall be that given in Section 1926.3.2.

**1926.7.7 Special provisions for slabs and footings.**

**1926.7.7.1** Shear capacity of slabs and footings in the vicinity of concentrated loads or reactions is governed by the more severe of the following two conditions:

**1926.7.7.1.1** Beam action for slab or footing with a critical section extending in a plane across the entire width and located at a distance  $d$  from face of concentrated load or reaction area. For this condition, the slab or footing shall be designed in accordance with Sections 1926.7.1 through 1926.7.5.

**1926.7.7.1.2** Two-way action for slab or footing with a critical section perpendicular to plane of slab and located so that its perimeter is a minimum but need not approach closer than  $d/2$  to perimeter of concentrated load or reaction area. For this condition, the slab or footing shall be designed in accordance with Sections 1926.7.7.2 and 1926.7.7.3.

**1926.7.7.2** Design shear stress  $v$  shall be computed by

$$v = \frac{V}{b_o d} \quad (26-9)$$

where  $V$  and  $b_o$  shall be taken at the critical section defined in Section 1926.7.7.1.2.

**1926.7.7.3** Design shear stress  $v$  shall not exceed  $v_c$  given by Formula (26-10) unless shear reinforcement is provided.

$$v_c = \left( 1 + \frac{2}{\beta_c} \right) \sqrt{f'_c} \quad (26-10)$$

For SI: 
$$v_c = 0.083 \left( 1 + \frac{2}{\beta_c} \right) \sqrt{f'_c}$$

but  $v_c$  shall not exceed  $2\sqrt{f'_c}$  (For SI:  $0.166\sqrt{f'_c}$ ).  $\beta_c$  is the ratio of long side to short side of concentrated load or reaction area. When lightweight aggregate concrete is used, the modifications of Section 1926.7.4.6 shall apply.

**1926.7.7.4** If shear reinforcement consisting of bars or wires is provided in accordance with Section 1911.12.3,  $v_c$  shall not exceed  $\sqrt{f'_c}$  (For SI:  $0.083\sqrt{f'_c}$ ), and  $v$  shall not exceed  $3\sqrt{f'_c}$  (For SI:  $0.25\sqrt{f'_c}$ ).

**1926.7.7.5** If shear reinforcement consisting of steel I or channel shapes (shearheads) is provided in accordance with Section 1911.12.4 of this code,  $v$  on the critical section defined in Section 1926.7.7.1.2 shall not exceed  $3.5\sqrt{f'_c}$  (For SI:  $0.29\sqrt{f'_c}$ ) and  $v$  on the critical section defined in Section 1911.12.4.7 shall not exceed  $2\sqrt{f'_c}$  (For SI:  $0.166\sqrt{f'_c}$ ). In Formulas (11-38) and (11-39), design shear force  $V$  shall be multiplied by 2 and substituted for  $V_u$ .

**1926.7.8 Special provisions for other members.** For design of deep flexural members, brackets and corbels and walls, the special provisions of Section 1911 shall be used with shear strengths provided by concrete and limiting maximum strengths for shear taken as 55 percent of the values given in Section 1911. In Section 1911.10.6, the design axial load shall be multiplied by 1.2 if compression and 2.0 if tension and substituted for  $N_u$ .

**1926.7.9 Composite concrete flexural members.** For design of composite concrete flexural members, permissible horizontal shear stress  $v_h$  shall not exceed 55 percent of the horizontal shear strengths given in Section 1917.5.2.

## SECTION 1927 — REINFORCED GYPSUM CONCRETE

**1927.1 General.** Reinforced gypsum concrete shall conform to U.B.C. Standard 19-15.

Reinforced gypsum concrete shall develop the minimum ultimate compressive strength in pounds per square inch (MPa) set forth in Table 19-F when dried to constant weight, with tests made on cylinders 2 inches (51 mm) in diameter and 4 inches (102 mm) long or on 2-inch (51 mm) cubes.

For special inspection, see Section 1701.

**1927.2 Design.** The minimum thickness of reinforced gypsum concrete shall be 2 inches (51 mm) except the thickness may be reduced to  $1\frac{1}{2}$  inches (38 mm), provided all of the following conditions are satisfied:

1. *The overall thickness, including the formboard, is not less than 2 inches (51 mm).*
2. *The clear span of the gypsum concrete between supports does not exceed 2 feet 9 inches (838 mm).*
3. *Diaphragm action is not required.*
4. *The design live load does not exceed 40 pounds per square foot (195 kg/m<sup>2</sup>).*

**1927.3 Stresses.** *The maximum allowable unit working stresses in reinforced gypsum concrete shall not exceed the values set forth in Table 19-G except as specified in Chapter 16. Bolt values shall not exceed those set forth in Table 19-H.*

*Allowable shear in poured-in-place reinforced gypsum concrete diaphragms using standard hot-rolled bulb tee subpurlins shall be determined by U.B.C. Standard 19-15. (See Table 19-15-A in the standard for values for commonly used roof systems.)*

TABLE 19-A-1—TOTAL AIR CONTENT FOR FROST-RESISTANT CONCRETE

NOMINAL MAXIMUM AGGREGATE SIZE (Inches) × 25.4 for mm	AIR CONTENT, PERCENTAGE	
	Severe Exposure	Moderate Exposure
3/8	7 1/2	6
1/2	7	5 1/2
3/4	6	5
1	6	4 1/2
1 1/2	5 1/2	4 1/4
2 <sup>1</sup>	5	4
3 <sup>1</sup>	4 1/2	3 1/2

<sup>1</sup>These air contents apply to total mix, as for the preceding aggregate sizes. When testing this concrete, however, aggregate larger than 1 1/2 inches (38 mm) is removed by hand picking or sieving, and air content is determined on the minus 1 1/2-inch (38 mm) fraction.

TABLE 19-A-2—REQUIREMENTS FOR SPECIAL EXPOSURE CONDITIONS

EXPOSURE CONDITION	MAXIMUM WATER-CEMENTITIOUS MATERIALS RATIO, BY WEIGHT, NORMAL-WEIGHT AGGREGATE CONCRETE	MINIMUM $f_c$ , NORMAL-WEIGHT AND LIGHTWEIGHT AGGREGATE CONCRETE, psi
		× 0.00689 for MPa
Concrete intended to have low permeability when exposed to water	0.50	4,000
Concrete exposed to freezing and thawing in a moist condition or to deicing chemicals	0.45	4,500
For corrosion protection for reinforced concrete exposed to chlorides from deicing chemicals, salts or brackish water, or spray from these sources	0.40	5,000

TABLE 19-A-3—REQUIREMENTS FOR CONCRETE EXPOSED TO SULFATE-CONTAINING SOLUTIONS

SULFATE EXPOSURE	WATER-SOLUBLE SULFATE (SO <sub>4</sub> ) IN SOIL, PERCENTAGE BY WEIGHT	SULFATE (SO <sub>4</sub> ) IN WATER, ppm	CEMENT TYPE	MAXIMUM WATER-CEMENTITIOUS MATERIALS RATIO, BY WEIGHT, NORMAL-WEIGHT AGGREGATE CONCRETE <sup>1</sup>	MINIMUM $f_c$ , NORMAL-WEIGHT AND LIGHTWEIGHT AGGREGATE CONCRETE, psi
					× 0.00689 for MPa
Negligible	0.00-0.10	0-150	—	—	—
Moderate <sup>2</sup>	0.10-0.20	150-1,500	II, IP(MS), IS (MS)	0.50	4,000
Severe	0.20-2.00	1,500-10,000	V	0.45	4,500
Very severe	Over 2.00	Over 10,000	V plus pozzolan <sup>3</sup>	0.45	4,500

<sup>1</sup>A lower water-cementitious materials ratio or higher strength may be required for low permeability or for protection against corrosion of embedded items or freezing and thawing (Table 19-A-2).

<sup>2</sup>Seawater.

<sup>3</sup>Pozzolan that has been determined by test or service record to improve sulfate resistance when used in concrete containing Type V cement.

**TABLE 19-A-4—MAXIMUM CHLORIDE ION CONTENT FOR CORROSION PROTECTION**

TYPE OF MEMBER	MAXIMUM WATER-SOLUBLE CHLORIDE ION (Cl) IN CONCRETE, PERCENTAGE BY WEIGHT OF CEMENTITIOUS MATERIALS
Prestressed concrete	0.06
Reinforced concrete exposed to chloride in service	0.15
Reinforced concrete that will be dry or protected from moisture in service	1.00
Other reinforced concrete construction	0.30

**TABLE 19-A-5—MODIFICATION FACTOR FOR STANDARD DEVIATION WHEN LESS THAN 30 TESTS ARE AVAILABLE**

NUMBER OF TESTS <sup>1</sup>	MODIFICATION FACTOR FOR STANDARD DEVIATION <sup>2</sup>
Less than 15	Use Table 19-A-6
15	1.16
20	1.08
25	1.03
30 or more	1.00

<sup>1</sup>Interpolate for intermediate numbers of tests.<sup>2</sup>Modified standard deviation to be used to determine required average strength  $f'_{cr}$  from Section 1905.3.2.1.**TABLE 19-A-6—REQUIRED AVERAGE COMPRESSIVE STRENGTH WHEN DATA ARE NOT AVAILABLE TO ESTABLISH A STANDARD DEVIATION**

SPECIFIED COMPRESSIVE STRENGTH $f'_c$ psi	REQUIRED AVERAGE COMPRESSIVE STRENGTH $f'_{cr}$ psi
× 0.00689 for MPa	
Less than 3,000 psi	$f'_c + 1,000$
3,000 to 5,000	$f'_c + 1,200$
Over 5,000	$f'_c + 1,400$

**TABLE 19-A-7—MAXIMUM PERMISSIBLE WATER-CEMENTITIOUS MATERIALS RATIOS FOR CONCRETE WHEN STRENGTH DATA FROM FIELD EXPERIENCE OR TRIAL MIXTURES ARE NOT AVAILABLE**

SPECIFIED COMPRESSIVE STRENGTH $f'_c$ psi <sup>1</sup>	ABSOLUTE WATER-CEMENTITIOUS MATERIALS RATIO BY WEIGHT	
	Nonair-entrained Concrete	Air-entrained Concrete
× 0.00689 for MPa		
2,500	0.67	0.54
3,000	0.58	0.46
3,500	0.51	0.40
4,000	0.44	0.35
4,500	0.38	2
5,000	2	2

<sup>1</sup>Twenty-eight-day strength. With most materials, water-cementitious materials ratios shown will provide average strengths greater than indicated in Section 1905.3.2 as being required.<sup>2</sup>For strengths above 4,500 psi (31.0 MPa) (nonair-entrained concrete) and 4,000 psi (27.6 MPa) (air-entrained concrete), concrete proportions shall be established by methods of Section 1905.3.

**TABLE 19-B—MINIMUM DIAMETERS OF BEND**

BAR SIZE	MINIMUM DIAMETER
Nos. 3 through 8	$6d_b$
Nos. 9, 10 and 11	$8d_b$
Nos. 14 and 18	$10d_b$

**TABLE 19-C-1—MINIMUM THICKNESS OF NONPRESTRESSED BEAMS OR ONE-WAY SLABS UNLESS DEFLECTIONS ARE COMPUTED<sup>1</sup>**

MEMBER	MINIMUM THICKNESS, $h$			
	Simply Supported	One End Continuous	Both Ends Continuous	Cantilever
	Members not supporting or attached to partitions or other construction likely to be damaged by large deflections			
Solid one-way slabs	$l/20$	$l/24$	$l/28$	$l/10$
Beams or ribbed one-way slabs	$l/16$	$l/18.5$	$l/21$	$l/8$

<sup>1</sup>Span length  $l$  is in inches.

Values given shall be used directly for members with normal-weight concrete [ $w_c = 145$  pcf (2323 kg/m<sup>3</sup>)] and Grade 60 reinforcement. For other conditions, the values shall be modified as follows:

(a) For structural lightweight concrete having unit weights in the range 90 to 120 pounds per cubic foot (1442 to 1922 kg/m<sup>3</sup>), the value shall be multiplied by (1.65 - 0.005  $w_c$ ) (For SI: 1.65 - 0.0003  $w_c$ ) but: not less than 1.09, where  $w_c$  is the unit weight in pounds per cubic foot (kg/m<sup>3</sup>).

(b) For  $f_y$  other than 60,000 psi (413.7 MPa), the values shall be multiplied by (0.4 +  $f_y/100,000$ ) (For SI: 0.4 +  $f_y/689.5$ ).

**TABLE 19-C-2—MINIMUM THICKNESS OF SLABS WITHOUT INTERIOR BEAMS**

YIELD STRENGTH, $f_y$ , psi* × 0.00689 for MPa	WITHOUT DROP PANELS*			WITH DROP PANELS <sup>1</sup>		
	Exterior Panels		Interior panels	Exterior Panels		Interior panels
	Without edge beams	With edge beams <sup>2</sup>		Without edge beams	With edge beams <sup>2</sup>	
40,000	$\frac{l_n}{33}$	$\frac{l_n}{36}$	$\frac{l_n}{36}$	$\frac{l_n}{36}$	$\frac{l_n}{40}$	$\frac{l_n}{40}$
60,000	$\frac{l_n}{30}$	$\frac{l_n}{33}$	$\frac{l_n}{33}$	$\frac{l_n}{33}$	$\frac{l_n}{36}$	$\frac{l_n}{36}$
75,000	$\frac{l_n}{28}$	$\frac{l_n}{31}$	$\frac{l_n}{31}$	$\frac{l_n}{31}$	$\frac{l_n}{34}$	$\frac{l_n}{34}$

\*For values of reinforcement yield strength between the values given in the table, minimum thickness shall be determined by linear interpolation.

<sup>1</sup>Drop panel is defined in Section 1913.4.7.

<sup>2</sup>Slabs with beams between columns along exterior edges. The value of  $\alpha$  for the edge beam shall not be less than 0.8.

**TABLE 19-D—VALUES OF  $\alpha_{min}$**

$\beta_n$	ASPECT RATIO $h_2/h_1$	RELATIVE BEAM STIFFNESS, $\alpha_{min}$				
		0	0.5	1.0	2.0	4.0
2.0	0.5-2.0	0	0	0	0	0
1.0	0.5	0.6	0	0	0	0
	0.8	0.7	0	0	0	0
	1.0	0.7	0.1	0	0	0
	1.25	0.8	0.4	0	0	0
	2.0	1.2	0.5	0.2	0	0
0.5	0.5	1.3	0.3	0	0	0
	0.8	1.5	0.5	0.2	0	0
	1.0	1.6	0.6	0.2	0	0
	1.25	1.9	1.0	0.5	0	0
	2.0	4.9	1.6	0.8	0.3	0
0.33	0.5	1.8	0.5	0.1	0	0
	0.8	2.0	0.9	0.3	0	0
	1.0	2.3	0.9	0.4	0	0
	1.25	2.8	1.5	0.8	0.2	0
	2.0	13.0	2.6	1.2	0.5	0.3

**TABLE 19-E—ALLOWABLE SERVICE LOAD ON EMBEDDED BOLTS (Pounds) (Newtons)<sup>1,2,3</sup>**

BOLT DIAMETER (Inches)	MINIMUM <sup>4</sup> EMBEDMENT (Inches)	EDGE DISTANCE (Inches)	SPACING (Inches)	MINIMUM CONCRETE STRENGTH (psi)					
				× 0.00689 for MPa					
				<i>f</i> ' <sub>c</sub> = 2,000		<i>f</i> ' <sub>c</sub> = 3,000		<i>f</i> ' <sub>c</sub> = 4,000	
				Tension <sup>5</sup>	Shear <sup>6</sup>	Tension <sup>5</sup>	Shear <sup>6</sup>	Tension <sup>5</sup>	Shear <sup>6</sup>
× 25.4 for mm				× 4.5 for newtons					
1/4	2 1/2	1 1/2	3	200	500	200	500	200	500
3/8	3	2 1/4	4 1/2	500	1,100	500	1,100	500	1,100
1/2	4	3	6	950	1,250	950	1,250	950	1,250
	4	5	6	1,400	1,550	1,500	1,650	1,550	1,750
5/8	4 1/2	3 3/4	7 1/2	1,500	2,750	1,500	2,750	1,500	2,750
	4 1/2	6 1/4	7 1/2	2,050	2,900	2,200	3,000	2,400	3,050
3/4	5	4 1/2	9	2,250	2,940	2,250	3,560	2,250	3,560
	5	7 1/2	9	2,700	4,250	2,950	4,300	3,200	4,400
7/8	6	5 1/4	10 1/2	2,550	3,350	2,550	4,050	2,550	4,050
1	7	6	12	2,850	3,750	3,250	4,500	3,650	5,300
1 1/8	8	6 3/4	13 1/2	3,400	4,750	3,400	4,750	3,400	4,750
1 1/4	9	7 1/2	15	4,000	5,800	4,000	5,800	4,000	5,800

<sup>1</sup>Values are natural stone aggregate concrete and bolts of at least A 307 quality. Bolts shall have a standard head or an equal deformity in the embedded portion.

<sup>2</sup>The tabulated values are for anchors installed at the specified spacing and edge distances. Such spacing and edge distance may be reduced 50 percent with an equal reduction in value. Use linear interpolation for intermediate spacings and edge margins.

<sup>3</sup>The allowable values may be increased per Section 1603.5 for duration of loads such as wind or seismic forces.

<sup>4</sup>An additional 2 inches (51 mm) of embedment shall be provided for anchor bolts located in the top of columns located in Seismic Zones 2, 3 and 4.

<sup>5</sup>Values shown are for work without special inspection. Where special inspection is provided, values may be increased 100 percent.

<sup>6</sup>Values shown are for work with or without special inspection.

**TABLE 19-F—MINIMUM COMPRESSIVE STRENGTH AND MODULUS OF ELASTICITY AND OF RIGIDITY OF REINFORCED GYPSUM CONCRETE**

CLASS	COMPRESSIVE STRENGTH psi ( $f'_c$ )	MODULUS OF ELASTICITY psi ( $E$ )	$E_g/E_g$ ( $n$ )	MODULUS OF RIGIDITY ( $G$ )
	× 0.00689 for MPa			
A	500	200,000	150	.36E
B	1,000	600,000	50	.40E

**TABLE 19-G—ALLOWABLE UNIT WORKING STRESS REINFORCED GYPSUM CONCRETE**

TYPE OF STRESS	FACTOR	CLASS A	CLASS B
		(pounds per square inch)	
		× 0.00689 for MPa	
Flexural compression	$.25f'_c$	125	250
Axial compression or bearing	$.20f'_c$	100	200
Bond for plain bars and shear <sup>1</sup>	$.02f'_c$	10	20
Bond for deformed bars and electrically welded wire mesh <sup>1</sup>	$.03f'_c$	15	30

<sup>1</sup>Electrically welded wire mesh reinforcement shall be considered as meeting the bond and shear requirements of this section. In no case shall the area of principal reinforcement be less than 0.26 square inch per foot (550 mm<sup>2</sup>/m) of slab width.

**TABLE 19-H—SHEAR ON ANCHOR BOLTS AND DOWELS—REINFORCED GYPSUM CONCRETE<sup>1</sup>**

BOLT OR DOWEL SIZE (Inches)	EMBEDMENT (Inches)	SHEAR <sup>2</sup> (Inches)
× 25.4 for mm		
$3/8$ bolt	4	325
$1/2$ bolt	5	450
$5/8$ bolt	5	650
$3/8$ deformed dowel	6	325
$1/2$ deformed dowel	6	450

<sup>1</sup>The bolts or dowels shall be spaced not closer than 6 inches (152 mm) on center.

<sup>2</sup>The tabulated values may be increased one third for bolts or dowels resisting wind or seismic forces.

TABLE 19-1—MAXIMUM PERMISSIBLE COMPUTED DEFLECTIONS

TYPE OF MEMBER	DEFLECTION TO BE CONSIDERED	DEFLECTION LIMITATION
Flat roofs not supporting or attached to nonstructural elements likely to be damaged by large deflections	Immediate deflection due to live load L	$\frac{l^1}{180}$
Floors not supporting or attached to nonstructural elements likely to be damaged by large deflections	Immediate deflection due to live load L	$\frac{l}{360}$
Roof or floor construction supporting or attached to nonstructural elements likely to be damaged by large deflections	That part of the total deflection occurring after attachment of nonstructural elements (sum of the long-time deflection due to all sustained loads and the immediate deflection due to any additional live loads) <sup>3</sup>	$\frac{l^2}{480}$
Roof or floor construction supporting or attached to nonstructural elements likely to not be damaged by large deflections		$\frac{l^4}{240}$

<sup>1</sup>The limit is not intended to safeguard against ponding. The member shall be checked for ponding by suitable calculations of deflection, including added deflections due to ponded water, and considering long-term effects of all sustained loads, camber, construction tolerances, and reliability of provisions for drainage.

<sup>2</sup>The limit may be exceeded if adequate measures are taken to prevent damage to supported or attached elements.

<sup>3</sup>Long-time deflection shall be determined in accordance with Section 1909.5.2.5 or 1909.5.4.2, but may be reduced by the amount of deflection calculated to occur before attachment of nonstructural elements. This amount shall be determined on basis of accepted engineering data relating to time-deflection characteristics of members similar to those being considered.

<sup>4</sup>But not greater than tolerance provided for nonstructural elements. The limits may be exceeded if camber is provided so that total deflection minus camber does not exceed limit.

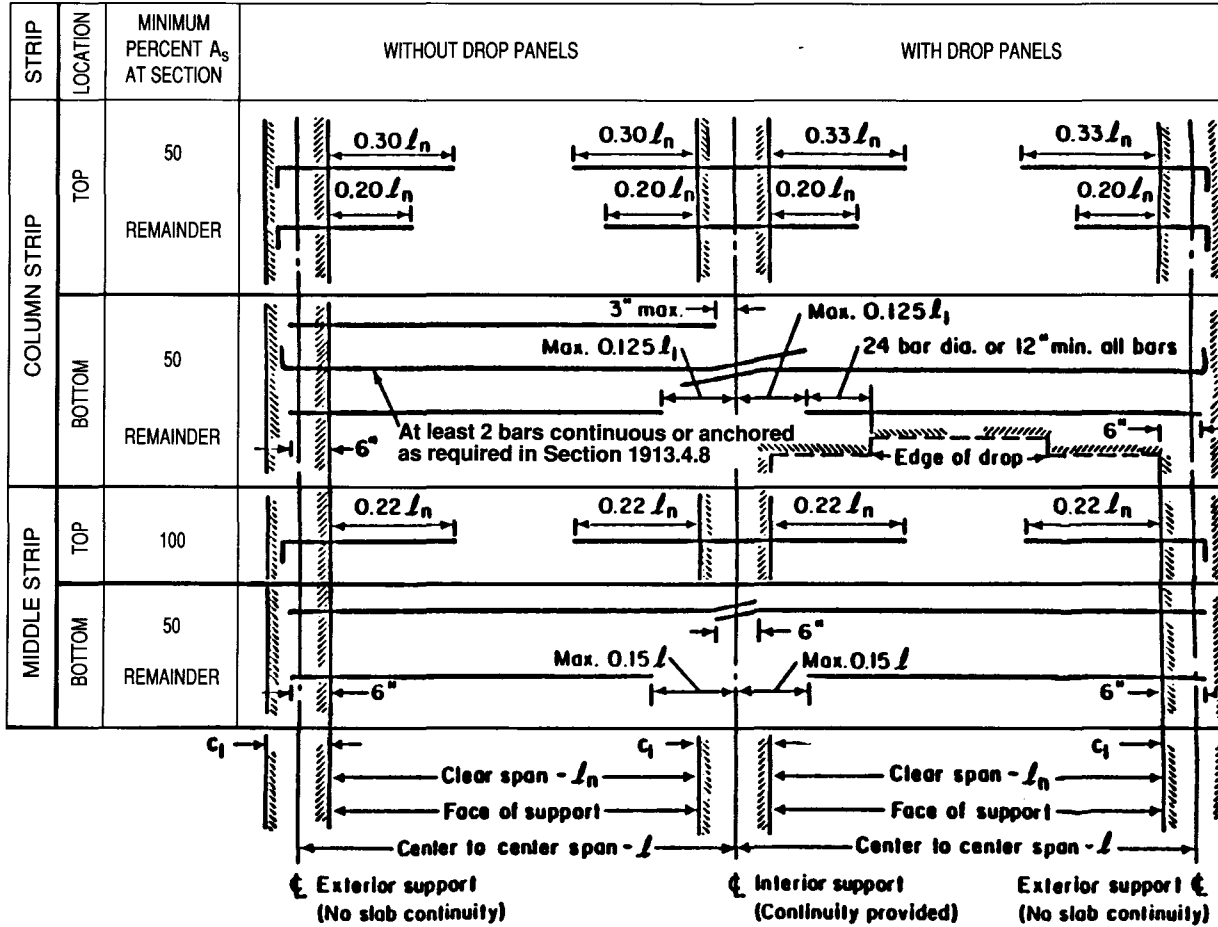

FIGURE 19-1—MINIMUM EXTENSIONS FOR REINFORCEMENT IN SLABS WITHOUT BEAMS  
 [See Section 1912.11.1 for reinforcement extension into supports.]

## Chapter 20 LIGHTWEIGHT METALS

### Division I—GENERAL

#### SECTION 2001 — MATERIAL STANDARDS AND SYMBOLS

**2001.1 General.** The quality, design, fabrication and erection of aluminum used structurally in buildings and structures shall conform to the requirements of this chapter, to other applicable requirements of this code and to Division II.

**2001.2 Alloys.** The use of aluminum alloys and tempers other than those covered by this chapter and other lightweight metal alloys are allowed for structural members and assemblies, provided standards of performance not less than those required by this chapter are substantiated to the satisfaction of the building official. When required by the building official, certification that the alloys and tempers called for on the plans have been furnished shall be provided.

**2001.3 Symbols and Notations.** The symbols and notations used in this chapter are defined as follows:

- $A$  = area, square inches ( $\text{mm}^2$ ).
- $A_c$  = area of compression element, square inches ( $\text{mm}^2$ ) (compression flange plus one third of area of web between compression flange and neutral axis).
- $A_w$  = area of cross section lying within 1.0 inch of a weld, square inches ( $\text{mm}^2$ ).
- $a_1$  = shorter dimension of rectangular panel, inches (mm).
- $a_2$  = longer dimension of rectangular panel, inches (mm).
- $a_e$  = equivalent width of rectangular panel, inches (mm).
- $B, D, C$   
= buckling formula constants, with following subscript:
  - $c$ —compression in columns
  - $p$ —compression in flat plates
  - $t$ —compression in round tubes
  - $tb$ —bending in round tubes
  - $b$ —bending in rectangular bars
  - $s$ —shear in flat plates
- $b$  = width of sections, inches (mm).
- $b/t$  = width-to-thickness ratio or rectangular element of a cross section.
- $c$  = distance from neutral axis to extreme fiber, inches (mm).
- $D$  = diameter, inches (mm).
- $d$  = depth of section or beam, inches (mm).
- $E$  = compressive modulus of elasticity, kips per square inch (ksi) (MPa).
- $F$  = allowable stress, ksi (MPa).
- $F_a$  = allowable compressive stress for member considered as an axially loaded column, ksi (MPa).
- $F_b$  = allowable compressive stress for member considered as a beam, ksi (MPa).
- $F_{bu}$  = bearing ultimate strength, ksi (MPa).
- $F_{buw}$  = bearing ultimate strength within 1.0 inch (25.4 mm) of a weld, ksi (MPa).
- $F_{by}$  = bearing yield strength, ksi (MPa).

- $F_{byw}$  = bearing yield strength within 1.0 inch (25.4 mm) of a weld, ksi (MPa).  
 $F_c$  = allowable compressive stress, ksi (MPa).  
 $F_{cy}$  = compressive yield strength, ksi (MPa).  
 $F_{cyw}$  = compressive yield strength across a butt weld (0.2 percent offset in 10-inch (254 mm) gage length), ksi (MPa).  
 $F_{ec}$  =  $\pi^2 E / [n_u (l/r)^2]$ , where  $l/r$  is slenderness ratio for member considered as a column tending to fail in the plane of the applied bending moments, ksi (MPa).  
 $F_n$  = allowable stress for cross section 1.0 inch (25.4 mm) or more from weld, ksi (MPa).  
 $F_{pw}$  = allowable stress on cross section, part of whose area lies within 1.0 (25.4 mm) inch of a weld, ksi (MPa).  
 $F_s$  = allowable shear stress for members subjected only to torsion or shear, ksi (MPa).  
 $F_{su}$  = shear ultimate strength, ksi (MPa).  
 $F_{suw}$  = shear ultimate strength within 1.0 inch (25.4 mm) of a weld, ksi (MPa).  
 $F_{sy}$  = shear yield strength, ksi (MPa).  
 $F_{syw}$  = shear yield strength within 1.0 inch (25.4 mm) of a weld, ksi (MPa).  
 $F_{tu}$  = tensile ultimate strength, ksi (MPa).  
 $F_{tuw}$  = tensile ultimate strength across a butt weld, ksi (MPa).  
 $F_{ty}$  = tensile yield strength, ksi (MPa).  
 $F_{tyw}$  = tensile yield strength across a butt weld [0.2 percent offset in 10-inch (254 mm) gage length], ksi (MPa).  
 $F_y$  = either  $F_{ty}$  or  $F_{cy}$ , whichever is smaller, ksi (MPa).  
 $f$  = calculated stress, ksi (MPa).  
 $f_a$  = average compressive stress on cross section of member produced by axial compressive load, ksi (MPa).  
 $f_b$  = maximum bending stress (compressive) caused by transverse loads or end moments, ksi (MPa).  
 $f_s$  = shear stress caused by torsion or transverse shear, ksi (MPa).  
 $G$  = modulus of elasticity in shear, ksi (MPa).  
 $g$  = spacing of rivet or bolt holes perpendicular to direction of load, inches (mm).  
 $h$  = clear height of shear web, inches (mm).  
 $I$  = moment of inertia, inches<sup>4</sup> (mm<sup>4</sup>).  
 $I_h$  = moment of inertia of horizontal stiffener, inches<sup>4</sup> (mm<sup>4</sup>).  
 $I_s$  = moment of inertia of transverse stiffener to resist shear buckling, inches<sup>4</sup> (mm<sup>4</sup>).  
 $I_x$  = moment of inertia of a beam about axis perpendicular to web, inches<sup>4</sup> (mm<sup>4</sup>).  
 $I_y$  = moment of inertia of a beam about axis parallel to web, inches<sup>4</sup> (mm<sup>4</sup>).  
 $I_{yc}$  = moment of inertia of compression element about axis parallel to vertical web, inches<sup>4</sup> (mm<sup>4</sup>).  
 $J$  = torsion constant, inches<sup>4</sup> (mm<sup>4</sup>).  
 $k_1$  = coefficient for determining slenderness limit  $S_2$  for sections for which the allowable compressive stress is based on crippling strength.  
 $k_2$  = coefficient for determining allowable compressive stress in sections with slenderness ratio above  $S_2$  for which the allowable compressive stress is based on crippling strength.  
 $k_c$  = coefficient for compression members.  
 $k_t$  = coefficient for tension members.  
 $L$  = length of compression member between points of lateral support, or twice the length of a cantilever column (except where analysis shows that a shorter length can be used), inches (mm).

- $L_b$  = length of beam between points at which the compression flange is supported against lateral movement, or length of cantilever beam from free end to point at which the compression flange is supported against lateral movement, inches (mm).
- $L_h$  = total length of portion of column lying within 1.0 inch (25.4 mm) of a weld (excluding welds at ends of columns that are supported at both ends), inches (mm).
- $L_w$  = increased length to be substituted in column formula to determine allowable stress for welded column, inches (mm).
- $L/r$  = slenderness ratio for columns.
- $M$  = bending moment, inch-kips (kN·m).
- $M_c$  = bending moment at center of span resulting from applied bending loads, inch-kips (kN·m).
- $M_m$  = maximum bending moment in span resulting from applied bending loads, inch-kips (kN·m).
- $M_1, M_2$   
= bending moments at two ends of a beam, inch-kips (kN·m).
- $N$  = length of bearing at reaction or concentrated load, inches (mm).
- $n_a$  = factor of safety on appearance of buckling.
- $n_u$  = factor of safety on ultimate strength.
- $n_y$  = factor of safety on yield strength.
- $P$  = local load concentration on bearing stiffener, kips (kN).
- $P_c$  = allowable reaction or concentrated load per web, kips (kN).
- $P_t$  = allowable tensile load per fastener, sheet to purlin or girt, kips (kN).
- $R$  = outside radius of round tube or maximum outside radius for an oval tube, inches (mm).
- $R_b$  = radius of curvature of tubular members, inches (mm).
- $R_t$  = transition radius, the radius of an attachment of the weld detail.
- $r$  = least radius of gyration of a column, inches (mm).
- $r_L$  = radius of gyration of lip or bulb about face of flange from which lip projects, inches (mm).
- $r_y$  = radius of gyration of a beam (about axis parallel to web), inches (mm). (For beams that are unsymmetrical about the horizontal axis,  $r_y$  should be calculated as though both flanges were the same as the compression flange.)
- $S_c$  = section modulus of a beam, compression side, inches<sup>3</sup> (mm<sup>3</sup>).
- $SR$  = stress ratio, the ratio of minimum stress to maximum stress.
- $S_t$  = section modulus of a beam, tension side, inches<sup>3</sup> (mm<sup>3</sup>).
- $S_1, S_2$  = slenderness limits.
- $s$  = spacing of transverse stiffeners (clear distance between stiffeners for stiffeners consisting of a pair of members, one on each side of the web, center-to-center distance between stiffeners consisting of a member on one side of the web only), inches (mm); spacing of rivet or bolt holes parallel to direction of load, inches (mm).
- $t$  = thickness of flange, plate, web or tube, inches (mm). (For tapered flanges,  $t$  is the average thickness.)
- $V$  = shear force on web at stiffener location, kips (kN).
- $\alpha$  = a factor equal to unity for a stiffener consisting of equal members on both sides of the web and equal to 3.5 for a stiffener consisting of a member on one side only.
- $\theta$  = angle between plane of web and plane of bearing surface ( $\theta \leq 90$ ), degrees.

**2001.4 Identification.** Aluminum for structural elements shall at all times be segregated or otherwise handled in the fabricator's plant so that the separate alloys and tempers are positively identi-

fied and, after completion of fabrication, shall be marked to identify the alloy and temper. Such markings shall be affixed to complete members and assemblies or to boxed or bundled shipments of multiple units prior to shipment from the fabricator's plant.

## SECTION 2002 — ALLOWABLE STRESSES FOR MEMBERS AND FASTENERS

**2002.1 Allowable Unit Stresses.** Except as modified by Division II, allowable unit stresses in aluminum alloy structural members shall be determined in accordance with the formulas of Table 20-I-C utilizing the safety factors listed in Table 20-I-D, and the constants and coefficients listed in Tables 20-I-E, 20-I-F and 20-I-G. Where two formulas are given, the smaller of the resulting stresses shall be used.

**2002.2 Welded Structural Members.** Allowable unit stresses for structural members whose entire cross-sectional area lies within 1 inch (25.4 mm) of the center line of a butt weld or the heel of a fillet weld shall be determined by means of the formulas of Table 20-I-C utilizing the applicable minimum expected mechanical properties for welded aluminum alloys listed in Division II. The tensile ultimate strength,  $F_{tuw}$ , shall be 90 percent of the American Society of Mechanical Engineers weld qualification test value of ultimate strength. Except as modified by Division II, buckling constants determined in accordance with the formulas of Tables 20-I-E and 20-I-G shall be calculated using the nonwelded mechanical properties of the respective aluminum alloys.

If less than 15 percent of the area of a given cross section lies within 1 inch (25.4 mm) of the center line of a butt weld or the heel of a fillet weld, the effect of the weld may be neglected and allowable stresses for nonwelded structural members may be used.

If the area of a cross section that lies within 1 inch (25.4 mm) of a weld is between 15 percent and 100 percent of the total area of the cross section, the allowable stress shall be calculated by the following formula:

$$F_{pw} = F_n - \frac{A_w}{A} (F_n - F_w)$$

**WHERE:**

- $A$  = net area of cross section of a tension member or tension flange of a beam, or gross area of cross section of a compression member or compression flange of a beam, square inches (mm<sup>2</sup>). (A beam flange is considered to consist of that portion of the member further than  $2c/3$  from the neutral axis, where  $c$  is the distance from the neutral axis to the extreme fiber.)
- $A_w$  = area of cross section lying within 1.0 inch (25.4 mm) of a weld.
- $F_n$  = allowable stress for cross section 1.0 inch (25.4 mm) or more from weld.
- $F_{pw}$  = allowable stress on cross section part of whose area lies within 1.0 inch (25.4 mm) of a weld.
- $F_w$  = allowable stress on cross section if entire area were to lie within 1.0 inch (25.4 mm) of a weld.

For columns and beams with welds at locations other than at their supported ends (not farther from the supports than  $0.05 L$  from the ends), and for cantilever columns and single web beams with transverse welds at or near the supported end, the effect of welding on allowable stresses shall be determined in accordance with the provisions of Division II.

**2002.3 Rivets and Bolts.** Allowable stresses in aluminum rivets and bolts shall be as set forth in Table 20-I-A.

**2002.4 Fillet Welds.** Allowable shear stresses in fillet welds shall be as set forth in Table 20-I-B.

**SECTION 2003 — DESIGN**

**2003.1 Combined Stresses.** Members subjected to combinations of compression and bending or shear, compression and bending shall be proportioned in accordance with the provisions of Division II.

**2003.2 Light Gage Members.** Where the design of light gage structural members is involved, the special provisions of Division II shall be applied.

**2003.3 Structural Roofing and Siding.** The live load deflection of structural roofing and siding made of formed sheet shall not exceed  $1/60$  of the span length.

**2003.4 Connections.** The design of mechanical and welded connections shall be in accordance with this chapter and the provisions of Division II.

**SECTION 2004 — FABRICATION AND ERECTION**

**2004.1 Cutting.** Oxygen cutting of aluminum alloys shall not be permitted.

**2004.2 Fasteners.** Bolts and other fasteners shall be aluminum, stainless steel or aluminized, hot-dip galvanized or electrogalvanized steel. Double cadmium-plated AN steel bolts may also be used. Steel rivets shall not be used except where aluminum is to be joined to steel or where corrosion resistance of the structure is not a requirement or where the structure is to be protected against corrosion.

**2004.3 Dissimilar Materials.** Where aluminum alloy parts are in contact with dissimilar metals, other than stainless, aluminized or galvanized steel or absorbent building materials likely to be continuously or intermittently wet, the faying surfaces shall be painted or otherwise separated in accordance with Division II.

**2004.4 Painting.** Except as prescribed in Section 2004.3, painting or coating of aluminum alloy parts shall be required only when called for on the plans.

**2004.5 Welding.** Aluminum parts shall be welded with an inert gas shielded arc or resistance welding process. No welding process that requires a welding flux shall be used. Filler alloys complying with the requirements of Division II shall be used.

**2004.6 Welder Qualification.** All welds of structural members shall be performed by welders qualified in accordance with the procedures of Division II.

**2004.7 Erection.** During erection, structural aluminum shall be adequately braced and fastened to resist dead, wind and erection loads.

TABLE 20-I-A—ALLOWABLE STRESSES FOR RIVETS

DESIGNATION BEFORE DRIVING	DRIVING PROCEDURE	DESIGNATION AFTER DRIVING	MINIMUM EXPECTED SHEAR STRENGTH (ksi)	ALLOWABLE SHEAR STRESS ON EFFECTIVE AREA (ksi)
			× 6.89 for MPa	
1100-H14	Cold, as received	1100-F	9.5	4
2017-T4	Cold, as received	2017-T3	34	14.5
2117-T4	Cold, as received	2117-T3	29	12
5056-H32	Cold, as received	5056-H321	26	11
6053-T61	Cold, as received	6053-T61	20	8.5
6061-T4	Hot, 990°F. to 1050°F.	6061-T43	21	9
6061-T6	Cold, as received	6061-T6	26	11 <sup>1</sup>
ALLOWABLE STRESSES FOR BOLTS				
ALLOY AND TEMPER	MINIMUM EXPECTED SHEAR STRENGTH (ksi)	ALLOWABLE <sup>2</sup> SHEAR STRESS ON EFFECTIVE AREA (ksi)	ALLOWABLE TENSILE STRESS ON ROOT AREA (ksi)	
	× 6.89 for MPa			
2024-T4	37	16	26	
6061-T6	27	12	18	
7075-T73	40	17	28	

<sup>1</sup>Also applies to 6061-T6 pins.

<sup>2</sup>Values apply to either turned bolts or unfinished bolts in holes not more than  $1/16$  inch (1.6 mm) oversized.

TABLE 20-I-B—ALLOWABLE SHEAR STRESSES IN FILLET WELDS (ksi)  
(Shear stress is considered equal to the load divided by the throat area.)

FILLER ALLOY	1100	4043	5356 5554	5556
	× 6.89 for MPa			
Parent Alloy				
1100	3.2	4.8	*	*
3003	3.2	5	*	*
Alclad 3004	*	5	7	8
5052	*	5	7	*
5083	*	*	*	8.5
5086	*	*	7	8.5
5454	*	*	7	8.5
5456	*	*	*	8.5
6061	*	5	7	8.5
6063	*	5	6.5	6.5

\* Not permitted.

TABLE 20-I-C—GENERAL FORMULAS FOR DETERMINING ALLOWABLE STRESSES

TYPE OF STRESS	TYPE OF MEMBER OR COMPONENT	SPEC. NO.	ALLOWABLE STRESS (ksi)			SLENDERNESS LIMIT, $S_2$	ALLOWABLE STRESS, KSI SLENDERNESS $\geq S_2$
			ALLOWABLE STRESS, KSI SLENDERNESS $< S_1$	SLENDERNESS LIMIT, $S_1$	ALLOWABLE STRESS, KSI SLENDERNESS BETWEEN $S_1$ AND $S_2$		
Tension, axial, net section	Any tension member:	1	$F_{ty}/n_y$ or $F_{tu}/(k_p u)$				
Tension in beams, extreme fiber, net section	Rectangular tubes, structural shapes bent about strong axis	2	$F_{ty}/n_y$ or $F_{tu}/(k_p u)$				$\times 6890$ for kN/m <sup>2</sup>
	Round or oval tubes	3	$1.17F_{ty}/n_y$ or $1.24F_{tu}/(k_p u)$				
	Rectangular bars, plates, shapes bent about weak axis	4	$1.30F_{ty}/n_y$ or $1.42F_{tu}/(k_p u)$				
Bearing	On rivets and bolts	5	$F_{by}/n_y$ or $1.42F_{bu}/(1.2n_u)$				
	On flat surfaces and pins and on bolts in slotted holes	6	$F_{by}/(1.5n_y)$ or $F_{bu}/(1.8n_u)$				
Compression in columns, axial, gross section	All columns	7	$\frac{F_{cy}}{k_c n_y}$	$\frac{L}{r} = \frac{B_c - \frac{n_u F_{cy}}{k_c n_y}}{D_c}$	$\frac{1}{n_u} (B_c - D_c \frac{L}{r})$	$\frac{L}{r} = C_c$	$\frac{\pi^2 E}{n_u (L/r)^2}$
Compression in components of columns, gross section	Outstanding flanges and legs	8	$\frac{F_{cy}}{k_c n_y}$	$\frac{b}{t} = \frac{B_p - \frac{n_u F_{cy}}{k_c n_y}}{5.1 D_p}$	$\frac{1}{n_u} (B_p - 5.1 D_p \frac{b}{t})$	$\frac{b}{t} = \frac{C_p}{5.1}$	$\frac{\pi^2 E}{n_u (5.1 b/t)^2}$
	Flat plates with both edges supported	9	$\frac{f_{cy}}{k_c n_y}$	$\frac{b}{t} = \frac{B_p - \frac{n_u F_{cy}}{k_c n_y}}{1.6 D_p}$	$\frac{1}{n_u} (B_p - 1.6 D_p \frac{b}{t})$	$\frac{b}{t} = \frac{k_1 B_p}{1.6 D_p}$	$\frac{k_2 \sqrt{B_p E}}{n_u (1.6 b/t)}$
	Curved plates supported on both edges, walls of round or oval tubes	10	$\frac{F_{cy}}{k_c n_y}$	$\frac{R}{t} = \left[ \frac{B_t - \frac{n_u F_{cy}}{k_c n_y}}{D_t} \right]^2$	$\frac{1}{n_u} (B_t - D_t \sqrt{\frac{R}{t}})$	$\frac{R}{t} = C_c$	$\frac{\pi^2 E}{16 n_u \left( \frac{R}{t} \right) \left( 1 + \frac{\sqrt{R/t}}{35} \right)^2}$
Compression in beams, extreme fiber, gross section	Single web beams bent about strong axis	11	$\frac{F_{cy}}{n_y}$	$\frac{L_b}{r_u} = \frac{1.2(B_c - F_{cy})}{D_c}$	$\frac{1}{n_y} (B_c - \frac{D_c L_b}{1.2 r_y})$	$\frac{L_b}{r_u} = 1.2 C_c$	$\frac{\pi^2 E}{n_u (L_b/1.2 r_u)^2}$
	Round or oval tubes	12	$\frac{1.17 F_{cy}}{n_y}$	$\frac{R_b}{t} = \left( \frac{B_{tb} - 1.17 F_{cy}}{D_{tb}} \right)^2$	$\frac{1}{n_u} (B_{tb} - D_{tb} \sqrt{\frac{R_b}{t}})$	$\frac{R_b}{t} = \left( \frac{\frac{n_u}{n_y} B_{tb} - B_t}{\frac{n_u}{n_y} D_{tb} - D_t} \right)^2$	Same as Specification 10 <sup>1</sup>

(Continued)

TABLE 20-I-C—GENERAL FORMULAS FOR DETERMINING ALLOWABLE STRESSES—(Continued)

TYPE OF STRESS	TYPE OF MEMBER OR COMPONENT	SPEC. NO.	ALLOWABLE STRESS, KSI, SLENDERNESS < S <sub>1</sub>	SLENDERNESS LIMIT, S <sub>1</sub>	ALLOWABLE STRESS, KSI SLENDERNESS BETWEEN S <sub>1</sub> AND S <sub>2</sub>	SLENDERNESS LIMIT, S <sub>2</sub>	ALLOWABLE STRESS, KSI SLENDERNESS ≥ S <sub>2</sub>
Compression in beams, extreme fiber, gross section (cont.)	Curved sections	12	$\frac{1.17F_{cy}}{n_y}$	$\frac{R}{t} = \left( \frac{B_t - 1.17F_{cy}}{D_t} \right)^2$	$\frac{1}{n_u} \left( B_t - D_t \sqrt{\frac{R}{t}} \right)$	$\frac{R}{t} = C_c$	$\frac{\pi^2 E}{16n_y \left( \frac{R}{t} \right) \left( 1 + \frac{\sqrt{R/t}}{35} \right)^2}$
	Solid rectangular beams	13	$\frac{1.3F_{cy}}{n_y}$	$\frac{d}{t} \sqrt{\frac{L_b}{d}} = \frac{B_b - 1.3F_{cy}}{2.3D_b}$	$\frac{1}{n_y} \left( B_b - 2.3D_b \frac{d}{t} \sqrt{\frac{L_b}{d}} \right)$	$\frac{d}{t} \sqrt{\frac{L_b}{d}} = \frac{C_b}{2.3}$	$\frac{\pi^2 E}{5.29n_y (d/t)^2 (L_b/d)}$
	Rectangular tubes and box sections	14	$\frac{F_{cy}}{n_y}$	$\frac{L_b S_c}{I_y} = \left( \frac{B_c - F_{cy}}{1.6D_c} \right)^2$	$\frac{1}{n_y} \left( B_c - 1.6D_c \sqrt{\frac{L_b S_c}{I_y}} \right)$	$\frac{L_b S_c}{I_y} = \left( \frac{C_c}{1.6} \right)^2$	$\frac{\pi^2 E}{2.56n_y (L_b S_c / I_y)}$
Compression in components of beams (component under uniform compression), gross section	Outstanding flanges	15	$\frac{F_{cy}}{n_y}$	$\frac{b}{t} = \frac{B_p - F_{cy}}{5.1D_p}$	$\frac{1}{n_y} (B_p - 5.1D_p \frac{b}{t})$	$\frac{b}{t} = \frac{k_1 B_p}{5.1D_p}$	$\frac{k_2 \sqrt{B_p E}}{n_y (5.1b/t)}$
	Flat plates with both edges supported	16	$\frac{F_{cy}}{n_y}$	$\frac{b}{t} = \frac{B_p - F_{cy}}{1.6D_p}$	$\frac{1}{n_y} (B_p - 1.6D_p \frac{b}{t})$	$\frac{b}{t} = \frac{k_1 B_p}{1.6D_p}$	$\frac{k_2 \sqrt{B_p E}}{n_y (5.1b/t)}$
Compression in components of beams (component under bending in own plane), gross section	Flat plates with compressed edge free tension edge supported	17	$\frac{1.3F_{cy}}{n_y}$	$\frac{b}{t} = \frac{B_b - 1.3F_{cy}}{3.5D_b}$	$\frac{1}{n_y} (B_b - 3.5D_b \frac{b}{t})$	$\frac{b}{t} = \frac{C_b}{3.5}$	$\frac{\pi^2 E}{n_u (3.5b/t)^2}$
	Flat plates with both edges supported	18	$\frac{1.3F_{cy}}{n_y}$	$\frac{h}{t} = \frac{B_b - 1.3F_{cy}}{0.67D_b}$	$\frac{1}{n_y} (B_b - 0.67D_b \frac{h}{t})$	$\frac{h}{t} = \frac{k_1 B_b}{0.67D_b}$	$\frac{k_2 \sqrt{B_b E}}{n_y (0.67h/t)}$
	Flat plates with horizontal stiffener, both edges supported	19	$\frac{1.3F_{cy}}{n_y}$	$\frac{h}{t} = \frac{B_b - 1.3F_{cy}}{0.29D_b}$	$\frac{1}{n_y} (B_b - 0.29D_b \frac{h}{t})$	$\frac{h}{t} = \frac{k_1 B_b}{0.29D_b}$	$\frac{k_2 \sqrt{B_b E}}{n_y (0.29h/t)}$
Shear in webs, gross section	Unstiffened flat webs	20	$\frac{F_{sy}}{n_y}$	$\frac{h}{t} = \frac{B_s - F_{sy}}{1.25D_s}$	$\frac{1}{n_y} (B_s - 1.25D_s \frac{h}{t})$	$\frac{h}{t} = \frac{C_s}{1.25}$	$\frac{\pi^2 E}{n_y (1.25h/t)^2}$
	Stiffened flat webs	21	$\frac{F_{sy}}{n_y}$	$\frac{a_e}{t} = \frac{B_s - \frac{n_u F_{sy}}{n_y}}{1.25D_s}$	$\frac{1}{n_a} (B_s - 1.25D_s \frac{a_e}{t})$	$\frac{a_e}{t} = \frac{C_s}{1.25}$	$\frac{\pi^2 E}{n_a (1.25a_e/t)^2}$

<sup>1</sup>For  $R_b/t$  values greater than  $S_2$ , the allowable bending shall be determined from the formula for tubes in compression, Specification 10, using the formula that is appropriate for the particular value of  $R_b/t$ . Note that in this case,  $R_b/t$  may be either less than or greater than the value of  $S_2$  for tubes in compression.

**TABLE 20-I-D—FACTORS OF SAFETY FOR USE WITH ALUMINUM ALLOWABLE STRESS SPECIFICATIONS**

	BUILDING AND SIMILAR TYPE STRUCTURES
1. Tension members F.S. on tensile strength, $n_u$ F.S. on yield strength, $n_y$	1.95 1.65
2. Columns F.S. on buckling strength, $n_u$ F.S. on crippling strength of thin sections, $n_u$ F.S. on yield strength for short columns, $n_y$	1.95 1.95 1.65
3. Beams F.S. on tensile strength, $n_u$ F.S. on tensile yield strength, $n_y$ F.S. on compressive yield strength for short beams, $n_y$ F.S. on buckling strength, $n_y$ F.S. on crippling strength of thin sections, $n_y$ F.S. on shear buckling of webs, $n_u$	1.95 1.65 1.65 1.65 1.65 1.20
4. Connections F.S. on bearing strength F.S. on bearing yield strength, $n_y$ F.S. on shear strength of rivets and bolts F.S. on shear strength of fillet welds F.S. on tensile strength of butt welds, $n_u$ F.S. on tensile yield strength of butt welds, $n_y$	$1.2 \times 1.95 = 2.34$ 1.65 $1.2 \times 1.95 = 2.34$ $1.2 \times 1.95 = 2.34$ 1.95 1.65

**TABLE 20-I-E—FORMULAS FOR BUCKLING CONSTANTS For All Products Whose Temper Designation begins with -O, -H, -T1, -T2, -T3 or -T4**

TYPE OF MEMBER AND STRESS	INTERCEPT (ksi)	SLOPE (ksi)	INTERSECTION
	× 6.89 for MPa		
1. Compression in columns and beam flanges	$B_c = F_{cy} \left[ 1 + \left( \frac{F_{cy}}{1000} \right)^{1/2} \right]$	$D_c = \frac{B_c}{20} \left( \frac{6B_c}{E} \right)^{1/2}$	$C_c = \frac{2B_c}{3D_c}$
2. Compression in flat plates	$B_p = F_{cy} \left[ 1 + \frac{(F_{cy})^{1/3}}{7.6} \right]$	$D_p = \frac{B_p}{20} \left( \frac{6B_p}{E} \right)^{1/2}$	$C_p = \frac{2B_p}{3D_p}$
3. Compression in round tubes under axial end load	$B_t = F_{cy} \left[ 1 + \frac{(F_{cy})^{1/5}}{5.8} \right]$	$D_t = \frac{B_t}{3.7} \left( \frac{B_t}{E} \right)^{1/3}$	$C_t^*$
4. Compressive bending stress in solid rectangular bars	$B_b = 1.3F_{cy} \left[ 1 + \frac{(F_{cy})^{1/3}}{7} \right]$	$D_b = \frac{B_b}{20} \left( \frac{6B_b}{E} \right)^{1/2}$	$C_b = \frac{2B_b}{3D_b}$
5. Compressive bending stress in round tubes	$B_{tb} = 1.5F_y \left[ 1 + \frac{(F_y)^{1/5}}{5.8} \right]$	$D_{tb} = \frac{B_{tb}}{2.7} \left( \frac{B_{tb}}{E} \right)^{1/3}$	$C_{tb} = \left( \frac{B_{tb} - B_t}{D_{tb} - D_t} \right)^2$
6. Shear stress in flat plates	$B_s = F_{sy} \left[ 1 + \frac{(F_{sy})^{1/3}}{6.2} \right]$	$D_s = \frac{B_s}{20} \left( \frac{6B_s}{E} \right)^{1/2}$	$C_s = \frac{2B_s}{3D_s}$
7. Crippling of flat plates in compression or bending	$k_1 = 0.50$	$k_2 = 2.04$	

\* $C_t$  can be found from a plot of the curves of allowable stress based on elastic and inelastic buckling or by a trial-and-error solution.

TABLE 20-I-F—VALUES OF COEFFICIENTS  $k_t$  and  $k_c$

ALLOY AND TEMPER	NONWELDED OR REGIONS FARTHER THAN 1.0 INCH (25.4 mm) FROM A WELD		REGIONS WITHIN 1.0 INCH (25.4 mm) OF A WELD	
	$k_t$	$k_c$	$k_t$	$k_c^1$
2014-T6, -T651	1.25	1.12	—	—
Alclad 2014-T6, -T651	1.25	1.12	—	—
6061-T6, -T651	1.0	1.12	1.0	1.0
6063-T5, -T6, -T83	1.0	1.12	1.0	1.0
6351-T5	1.0	1.12	1.0	1.0
All others listed in Division II	1.0	1.10	1.0	1.0

<sup>1</sup>If the weld yield strength exceeds 0.9 of the parent metal yield strength, the allowable compressive stress within 1.0 inch (25.4 mm) of a weld should be taken equal to the allowable stress for nonwelded material.

TABLE 20-I-G—FORMULAS FOR BUCKLING CONSTANTS  
For all products whose temper designation begins with -T5, -T6, -T7, -T8 or -T9

TYPE OF MEMBER AND STRESS	INTERCEPT (ksi)	SLOPE (ksi)	INTERSECTION
	× 6.89 for MPa		
1. Compression in columns and beam flanges	$B_c = F_{cy} \left[ 1 + \left( \frac{F_{cy}}{2250} \right)^{1/2} \right]$	$D_c = \frac{B_c}{10} \left( \frac{B_c}{E} \right)^{1/2}$	$C_c = 0.41 \frac{B_c}{D_c}$
2. Compression in flat plates	$B_p = F_{cy} \left[ 1 + \frac{(F_{cy})^{1/3}}{11.4} \right]$	$D_p = \frac{B_p}{10} \left( \frac{B_p}{E} \right)^{1/2}$	$C_p = 0.41 \frac{B_p}{D_p}$
3. Compression in round tubes under axial end load	$B_t = F_{cy} \left[ 1 + \frac{(F_{cy})^{1/5}}{8.7} \right]$	$D_t = \frac{B_t}{4.5} \left( \frac{B_t}{E} \right)^{1/3}$	$C_t =$
4. Compressive bending stress in solid rectangular bars	$B_b = 1.3F_{cy} \left[ 1 + \frac{(F_{cy})^{1/3}}{7} \right]$	$D_b = \frac{B_b}{20} \left( \frac{6B_b}{E} \right)^{1/2}$	$C_b = \frac{2B_b}{3D_b}$
5. Compressive bending stress in round tubes	$B_{tb} = 1.5F_y \left[ 1 + \frac{(F_y)^{1/5}}{8.7} \right]$	$D_{tb} = \frac{B_{tb}}{2.7} \left( \frac{B_{tb}}{E} \right)^{1/3}$	$C_{tb} = \left( \frac{B_{tb} - B_t}{D_{tb} - D_t} \right)^2$
6. Shear stress in flat plates	$B_s = F_{sy} \left[ 1 + \frac{(F_{sy})^{1/3}}{9.3} \right]$	$D_s = \frac{B_s}{10} \left( \frac{B_s}{E} \right)^{1/2}$	$C_s = 0.41 \frac{B_s}{D_s}$
7. Crippling of flat plates in compression	$k_1 = 0.35$	$k_2 = 2.27$	
8. Crippling of flat plates in bending	$k_1 = 0.50$	$k_2 = 2.04$	

\* $C_t$  can be found from a plot of the curves of allowable stress based on elastic and inelastic buckling or by a trial-and-error solution.

**Division II—DESIGN STANDARD FOR ALUMINUM STRUCTURES**  
**Based on Specifications for Aluminum Structures of The Aluminum Association**  
**(December, 1986)**

**SECTION 2005 — SCOPE**

This standard covers design of aluminum alloy load-carrying members.

**SECTION 2006 — MATERIALS**

The principal materials to which this standard applies are aluminum alloys registered with The Aluminum Association. Those frequently used for structural members are listed in Table 20-II-A. Applicable American Society for Testing and Materials (ASTM) specifications are designations B 209, B 210, B 211, B 221, B 241, B 247, B 308 and B 429.

**SECTION 2007 — DESIGN**

Design shall be in accordance with Division I and other applicable provisions of this code.

Properties of section, such as cross-sectional area, moment of inertia, section modulus, radius of gyration, etc., shall be determined by accepted methods of engineering design. Computations of forces, moments, stresses and deflection shall be in accordance with accepted principles of elastic structural analyses.

**SECTION 2008 — ALLOWABLE STRESSES**

Allowable stresses shall be determined in accordance with the provisions of Division I.

**SECTION 2009 — SPECIAL DESIGN RULES**

**2009.1 Combined Compression and Bending.** A member subjected to axial compression and carrying a bending moment due to lateral or eccentric loads shall be proportioned in accordance with the following formulas:

1. Bending moment at center equal to or greater than 0.9 of maximum bending moment in span:

$$\frac{f_a}{F_a} + \frac{f_b}{F_b(1 - f_a/F_{ec})} \leq 1$$

2. Bending moment at center equal to or less than 0.5 of maximum bending moment in span:

$$\frac{f_a}{F_a} + \frac{f_b}{F_b} \leq 1$$

3. Bending moment at center between 0.5 and 0.9 maximum bending moment in span:

$$\frac{f_a}{F_a} + \frac{f_b}{F_b \left[ 1 - \left( \frac{2M_c}{M_m} - 1 \right) \frac{f_a}{F_{ec}} \right]} \leq 1$$

**WHERE:**

$M_c$  = bending moment at center of span.

$M_m$  = maximum bending moment in span.

**2009.2 Torsion and Shear in Tubes.** Allowable shear stresses in round or oval tubes due to torsion or transverse shear loads shall be determined from Specification 20 in Table 20-I-C with the ratio  $h/t$  replaced by an equivalent  $h/t$  given by the following:

$$\text{Equivalent } \frac{h}{t} = 2.9 \left( \frac{R}{t} \right)^{5/8} \left( \frac{L_t}{R} \right)^{1/4}$$

**WHERE:**

$L_t$  = length of tube between circumferential stiffeners, inches (mm). Equivalent ( $h/t$ ) = value to be substituted for  $h/t$  in Specification 20 in Table 20-I-C.

**2009.3 Combined Shear, Compression and Bending.** Allowable combinations of shear, compression and bending, as in the web of a beam column or the wall of a tube, shall be determined from the following formula:

$$\frac{f_a}{F_a} + \frac{f_b}{F_b} + \left( \frac{f_s}{F_s} \right)^2 \leq 1.0$$

**2009.4 Stiffeners for Outstanding Flanges.** Outstanding flanges stiffened by lips or bulbs at the free edge shall be considered as supported on both edges if the radius of gyration of the lip or bulb meets the following requirement:

$$r_L = \frac{b}{5}$$

For simple rectangular lips having the same thickness as the flange, as in the case of formed sheet construction, the preceding requirement can be expressed as:

$$b_L = b/3$$

**WHERE:**

$b_L$  = clear width of lip, inches (mm).

Allowable stresses for flanges with lips or bulbs meeting the foregoing requirements shall be determined from Specifications 15 and 16 in Table 20-I-C. The area of stiffening lips or bulbs may be included with the area of the rest of the section in calculating the stresses caused by the loads.

**2009.5 Horizontal Stiffeners for Shear Webs.** If a horizontal stiffener is used on a beam web, it shall be located so that the distance from the toe of the compression flange to the centroid of the stiffener is 0.4 of the distance from the toe of the compression flange to the toe of the tension flange. The horizontal stiffener shall have a moment of inertia about the web of the beam not less than that given by the expression:

$$I_h = 2_\alpha f t h^3 \left[ \left( 1 + \frac{6A_h}{ht} \right) \left( \frac{s}{h} \right)^2 + 0.4 \right] 10^{-6}$$

For SI:  $\times 416\ 231$  for  $\text{mm}^4$

**WHERE:**

$A_h$  = gross area of cross section of horizontal stiffener, inches<sup>2</sup>.

$\alpha$  = 1, for stiffener consisting of equal members on both sides of the web.

$\alpha$  = 3.5, for stiffener consisting of member on only one side of web.

For stiffener consisting of equal members on both sides of the web, the moment of inertia,  $I_h$ , shall be the sum of the moments of inertia about the center line of the web. For a stiffener consisting of a member on one side only, the moment of inertia shall be taken about the face of the web in contact with the stiffener.

**2009.6 Vertical Stiffeners for Shear Webs.** Stiffeners applied to beam webs to resist shear buckling shall have a moment of inertia not less than the value given by the following expressions:

$$\frac{s}{h} \leq 0.4, \quad I_s = \frac{n_a V h^2}{22,400} \left( \frac{s}{h} \right)$$

For SI:  $\times 416\,231$  for  $\text{mm}^4$

$$\frac{s}{h} \geq 0.4, \quad I_s = \frac{n_a V h^2}{140,000} \left( \frac{h}{s} \right)$$

For SI:  $\times 416\,231$  for  $\text{mm}^4$

When a stiffener is composed of a pair of members, one on each side of the web, the stiffener spacing,  $s$ , shall be the clear distance between the pairs of stiffeners. When a stiffener is composed of a member on one side only of the web, the stiffener spacing,  $s$ , shall be the distance between rivet lines or other connecting lines.

For a stiffener composed of members of equal size on each side of the web, the moment of inertia of the stiffener shall be computed about the center line of the web. For a stiffener composed of a member on one side only of the web, the moment of inertia of the stiffener shall be computed about the face of the web in contact with the stiffener.

In the determination of the required moment of inertia of stiffeners, the distance,  $h$ , shall always be taken as the full clear height of the web regardless of whether or not a horizontal stiffener is present.

Stiffeners shall extend from flange to flange but need not be connected to either flange.

Unless the outer edge of a stiffener is continuously stiffened, its thickness shall not be less than one twelfth the clear width of the outstanding leg.

Vertical stiffeners shall, where possible, be placed in pairs at end bearings and at points of support of concentrated loads. They shall be connected to the web by enough rivets, or other means, to transmit the load. Such stiffeners shall be fitted to form a tight and uniform bearing against the loaded flanges unless welds, designed to transmit the full reaction or load, are provided between flange and stiffener.

Only that part of a stiffener cross section which lies outside the fillet of the flange angle shall be considered as effective in bearing. Bearing stiffeners shall not be joggled.

The moment of inertia of the bearing stiffener shall not be less than that given by the following expression:

$$I_b = I_s + \frac{P h^2 n_u}{\pi^2 E}$$

For SI:  $\times 416\,231$  for  $\text{mm}^4$

**WHERE:**

$I_b$  = required moment of inertia of bearing stiffener, inches<sup>4</sup> ( $\text{mm}^4$ ).

**2009.7 Special Provisions for Thin Sections.**

**2009.7.1 Appearance of buckling.** For very thin sections the allowable compressive stresses given in Specifications 9, 15, 16, 18 and 19 of Table 20-I-C may result in visible local buckling, even though an adequate margin of safety is provided against ultimate failure. In applications where any appearance of buckling must be avoided, the allowable stresses for thin sections shall not exceed the value of  $F_{ab}$  given by the following formulas:

SPECIFICATION	ALLOWABLE STRESS, $F_{ab}$ ksi (MPa)
9, 16	$F_{ab} = \frac{\pi^2 E}{n_a(1.6b/t)^2}$
15	$F_{ab} = \frac{\pi^2 E}{n_a(5.1b/t)^2}$
18	$F_{ab} = \frac{\pi^2 E}{n_a(0.67h/t)^2}$
19	$F_{ab} = \frac{\pi^2 E}{n_a(0.29h/t)^2}$

**2009.7.2 Weighted average allowable compressive stress.** The cross section of a compression member may be composed of several thin elements, for which allowable stresses are determined by Specification 8, 9 or 10 of Table 20-I-C. The allowable compressive stress for the section as a whole may be considered to be the weighted average allowable stress for the individual elements, where the allowable stress for each element is weighted in accordance with the ratio of the area of the element to the total area of the section. The allowable compressive stress for the section as a whole used as a column must not exceed that given by Specification 7 of Table 20-I-C.

Weighted average allowable compressive stresses for beam flanges may be calculated in the same way, where the allowable stresses for individual elements are determined from Specifications 15 through 19 of Table 20-I-C. The beam flange may be considered to consist of the flange proper plus one sixth of the area of the web or webs.

**2009.7.3 Trapezoidal-formed sheet beams.** The weighted average allowable compressive stress for a trapezoidal-formed sheet beam, calculated according to paragraph 2, is:

$$F_{ba} = \frac{F_{bf} + F_{bh} \left( \frac{h}{3b} \right)}{1 + \frac{h}{3b}}$$

**WHERE:**

$F_{ba}$  = weighted average allowable compressive stress for beam flange, ksi (MPa).

$F_{bf}$  = allowable stress for flange proper based on Specification 16 of Table 20-I-C.

$F_{bh}$  = allowable stress for webs based on Specification 18 or 19 of Table 20-I-C.

The foregoing formula may also be applied to the allowable tensile stress in trapezoidal-formed sheet beams, if the designer wishes to take full advantage of the strength of the section. In this case,  $F_{ba}$  is the weighted average allowable tensile stress,  $F_{bf}$  is determined from Specification 2 in Table 20-I-C, and  $F_{bh}$  is given by Specification 4 in Table 20-I-C.

In regions of negative bending moment (for example, at interior supports of multiple-span beams) the allowable tensile stress on the tension flange of a formed sheet beam shall not exceed the compressive stress that would be allowed on the same flange if it were in compression.

**2009.7.4 Effect of local buckling on column strength.** An additional limitation must be placed on the allowable stress for very thin-walled columns whose cross section is a rectangular tube or a formed sheet shape such that the flanges consist of flat elements supported on both edges. If the  $b/t$  for the flange of such a column is less than the value of  $S_2$  in Specification 9 of Table 20-I-C, or less than 0.6 of the maximum slenderness ratio ( $L/r$ ) for the column, no additional reduction in allowable stress is necessary. However, if the maximum  $b/t$  for the flange is greater than the value of  $S_2$  from Specification 9 of Table 20-I-C, and also greater than 0.6 of the maximum slenderness ratio for the column, the allowable column stress shall not exceed the value given by

$$F_{rc} = \frac{\pi^2 E}{n_u (L/r)^{2/3} (1.6b/t)^{4/3}}$$

**WHERE:**

$F_{rc}$  = reduced allowable stress on column, ksi.

The allowable stress shall also not exceed the value given by Specification 9 of Table 20-I-C.

**2009.7.5 Effect of local buckling on beam strength.** The allowable compressive bending stress for single web beams whose flanges consist of thin, flat elements supported on one edge shall also be reduced in the case where the value of  $b/t$  for the flange is greater than the value of  $S_2$  from Specification 15 of Table 20-I-C, and also greater than  $0.16 (L_b/r_y)$ . In this case, the allowable beam stress shall not exceed

$$F_{rb} = \frac{\pi^2 E}{n_u (L_b/1.2r_y)^{2/3} (5.1b/t)^{4/3}}$$

**WHERE:**

$F_{rb}$  = reduced allowable compressive bending stress in beam flange, ksi.

$L_b/r_y$  = slenderness ratio for beam.

**2009.7.6 Effective width for calculation of deflection of thin gage sections.** As noted in paragraph 1, the allowable compressive stresses given in Specifications 9, 15, 16, 18 and 19 of Table 20-I-C may result in some local buckling at design loads for very thin sections even though an adequate margin of safety is provided against ultimate failure. This local buckling may result in increased deflections for sections containing thin elements with  $b/t$  value exceeding  $1.65 S_2$ , where the value of  $S_2$  is obtained for the element in question from Specifications 9, 15, 16, 18 and 19 of Table 20-I-C.

Where deflection at design loads is critical, the effective width concept may be used to determine an effective section to be used in deflection calculations. The effective width,  $b_e$ , of a thin element subjected to direct compression stresses is:

$$\text{If } f_a \leq n_a F_{ab}, \quad b_e = b$$

$$\text{If } f_a > n_a F_{ab}, \quad b_e = b \sqrt{n_a F_{ab} / f_a}$$

**WHERE:**

$b_e$  = effective width of flat plate element to be used in deflection calculations, inches (mm).

$F_{ab}$  = allowable stress for element from Subsection (g), ksi (MPa).

The same expression may be used to calculate the effective width on the compression side of a web in bending, with the compressive bending stress due to the applied loads,  $f_b$ , replacing  $f_a$ .

**2009.7.7 Web crippling.** For structural formed sheet roofing and siding, allowable interior reactions and concentrated loads for flat webs shall not exceed

$$P_c = 600 \frac{F_{cy} dt^2}{w} \left( 6 + 0.04 \frac{N}{t} \right)$$

$$\left[ 1.1 - 0.1 \left( \frac{\theta}{90} \right) \sqrt{\frac{r}{t}} \right] \text{ for } \frac{w}{t} \leq C_p$$

$$\text{and } P_c = 1,500 E d (N + w) \left( \frac{t}{w} \right)^3 \text{ for } \frac{w}{t} > C_p$$

$$\text{in which } C_p = \frac{2.5E \left( \frac{N}{t} + 1 \right)}{F_{cy} \left( 6 + 0.04 \frac{N}{t} \right) \left[ 1.1 - 0.1 \left( \frac{\theta}{90} \right) \sqrt{\frac{r}{t}} \right]}$$

Allowable end reactions shall not exceed

$$P_c = 600 \frac{F_{cy} dt^2}{w} \left( 3 + 0.04 \frac{N}{t} \right)$$

$$\left[ 1.1 - 0.1 \left( \frac{\theta}{90} \right) \sqrt{\frac{r}{t}} \right] \text{ for } \frac{w}{t} \leq C_p$$

$$\text{and } P_c = 1,500 Ed \left( N + \frac{w}{2} \right) \left( \frac{t}{w} \right)^3 \text{ for } \frac{w}{t} > C_p$$

$$\text{in which } C_p = \frac{1.25E \left( \frac{2N}{w} + 1 \right)}{F_{cy} \left( 3 + 0.04 \frac{N}{t} \right) \left[ 1.1 - 0.1 \left( \frac{\theta}{90} \right) \sqrt{\frac{r}{t}} \right]}$$

**WHERE:**

- $d$  = depth (vertical projection), inches (mm).
- $F_{cy}$  = minimum compressive yield strength of sheet, in kips per square inch (MPa).
- $N$  = length of bearing at reaction or concentrated load, inches (mm).
- $P_c$  = allowable reaction or concentrated load per web, pounds (N).
- $r$  = bend radius at juncture of flange and web of trapezoidal section, measured to inside surface of bend, inches (mm).
- $t$  = sheet thickness, inches (mm).
- $w$  = slope width of web (shear element spanning between flats) of trapezoidal section, inches (mm).
- $\theta$  = angle between plane of web of trapezoidal section and plane of bearing surface ( $\theta \leq 90$ ), degrees.

**2009.8 Fatigue.** For up to 100,000 repetitions of maximum live load, if nonwelded, and 20,000 repetitions of maximum live load if welded, allowable stresses shall be determined in accordance with Table 20-I-C and Section 2010.1 provided that the structural members are free of re-entrant corners and other unusual stress raisers. For repetitions of loads in excess of these values, allowable stresses shall be determined by a special analysis.

**2009.9 Compression in Single-web Beams.** The formulas of Specification 11 of Table 20-I-C for single-web beams and girders, are based on an approximation in which the term  $L_b/r_y$  replaces a more complicated expression involving several different properties of the beam cross section. Because of this approximation, the formulas give very conservative results for certain conditions, namely for values of  $L_b/r_y$  exceeding about 50; for load distributions such that the bending moment near the center of the beam is appreciably less than the maximum bending moment in the beam; and for beams with transverse loads applied to the bottom flange. If the designer wishes to compute more precise values of allowable compressive stress for these cases, the value of  $r_y$  in Specification 11 of Table 20-I-C may be replaced by an "effective  $r_y$ " given by one of the following formulas:

Beam spans subjected to end moment only or to transverse loads applied at the neutral axis of the beam:

$$\text{Effective } r_y = \frac{k_b}{1.7} \sqrt{\frac{I_y d}{S_c}} \sqrt{1 + 0.152 \frac{J}{I_y} \left( \frac{L_b}{d} \right)^2}$$

For SI:  $\times 25.4$  for mm

Beams subjected to transverse loads applied on the top or bottom flange (where the load is free to move laterally with the beam if the beam should buckle):

Effective  $r_y =$

$$\frac{k_b}{1.7} \sqrt{\frac{I_y d}{S_c} \left[ \pm 0.5 + \sqrt{1.25 + 0.152 \frac{J}{I_y} \left(\frac{L_b}{d}\right)^2} \right]}$$

For SI:  $\times 25.4$  for mm

The plus sign in front of the term “0.5” applies if the load is on the bottom flange, the minus sign if the load is on the top flange.

Effective  $r_y =$  value to be substituted for  $r_y$  in Specification 11 of Table 20-I-C.

The terms appearing in the above formulas are defined in this code.

Values of the coefficient,  $k_b$ , follow:

<b>BEAMS RESTRAINED AGAINST LATERAL DISPLACEMENT AT BOTH ENDS OF SPAN</b>	<b>VALUE OF COEFFICIENT <math>k_b</math></b>
Uniform bending moment, uniform transverse load, or two equal concentrated loads equidistant from the center of the span .....	1.00
Bending moment varying uniformly from a value of $M_1$ at one end to $M_2$ at the other end	
$M_1/M_2 = 0.5$ .....	1.14
$M_1/M_2 = 0$ .....	1.33
$M_1/M_2 = -0.5$ .....	1.53
$M_1/M_2 = -1.0$ .....	1.60
Concentrated load at center of span .....	1.16
<b>CANTILEVER BEAMS</b>	
Concentrated load at end of span .....	1.13
Uniform transverse load .....	1.43

**2009.10 Compression in Elastically Supported Flanges.** Allowable compressive stresses in elastically supported flanges, such as the compression flange of a standing seam roof or of a hat-shaped beam loaded with the two flanges in compression, shall be determined from Specification No. 11 with the following effective value of  $L_b/r_y$  substituted in the formulas for allowable stress.

$$\text{Effective } \frac{L_b}{r_y} = 2.7 \sqrt[4]{\frac{EA_c^2}{\beta I_{yc}}}$$

**WHERE:**

$\beta =$  spring constant [transverse force in kips applied to a 1-inch (25.4 mm) length of the member at the compression flange to cause a 1-inch (25.4 mm) deflection of the flange], ksi (MPa).

**SECTION 2010 — MECHANICAL CONNECTIONS**

**2010.1 Riveted and Bolted Connections.** Aluminum alloys used for rivets and bolts shall be those listed in Table 20-I-A. Nuts for 1/4-inch (6.4 mm) bolts and smaller shall be 2024-T4. Nuts for larger diameter bolts shall be alloy 6061-T6 or 6262-T9. Flat washers shall be Alclad 2024-T4. Spring lock washers shall be alloy 7075-T6. For improved corrosion resistance, a 0.0002-inch (0.005 mm) minimum thickness anodic coating may be applied to alloy 2024 bolts.

**2010.1.1 Allowable loads.** The allowable loads on rivets and bolts shall be calculated using the allowable bearing stresses in Table 20-I-C and the allowable shear stresses in Table 20-I-A. The

allowable bearing stress depends on the ratio of edge distance to rivet or bolt diameter where the edge distance is the distance from the center of the rivet or bolt to the edge of the load-carrying member toward which the pressure of the rivet or bolt is directed.

Allowable bearing stresses on bolts apply to either threaded or unthreaded surfaces.

**2010.1.2 Effective diameter.** The effective diameter of rivets shall be taken as the hole diameter, but shall not exceed the nominal diameter of the rivet by 4 percent for cold driven rivets and 7 percent for hot driven rivets. The effective diameter of bolts shall be taken as the nominal diameter of the bolt.

**2010.1.3 Shear area.** The effective area of a rivet or bolt in any shear plane shall be based on the effective diameter except that for bolts with threads included in the shear plane, the effective shear area shall be based on the root diameter.

**2010.1.4 Bearing area.** The effective bearing area of rivets or bolts shall be the effective diameter multiplied by the length in bearing except that for countersunk rivets, half of the depth of the countersink shall be deducted from the length.

**2010.1.5 Arrangements and strength of connections.** Insofar as possible, connections shall be arranged so that the center of resistance of the connection shall coincide with the resultant line of action of the load. Where eccentricity exists, members and connections shall be proportioned to take into account any eccentricity of loading at the connections.

**2010.1.6 Net section.** The net section of a riveted or bolted tension member shall be determined as the sum of the net sections of its component parts. The net section of a part is the product of the thickness of the part multiplied by its least net width. The net width for a chain of holes extending across the part in any straight or broken line shall be obtained by deducting from the gross width the sum of the diameters of all the holes in the chain and adding  $s^2/4g$  for each gage space in the chain. In the correction quantity  $s^2/4g$ ,  $s$  denotes spacing parallel to the direction of the load (pitch) of any two successive holes in the chain, in inches, and  $g$  refers to gage, the spacing perpendicular to the direction of the load of the same holes, in inches (mm).

The net section of the part shall be obtained from that chain which gives the least net width. The hole diameter to be deducted shall be the actual hole diameter for drilled or reamed holes and the hole diameter plus  $1/32$  inch (0.794 mm) for punched holes.

For angles, the gross width shall be the sum of the widths of the legs less the thickness. The gage for holes in opposite legs shall be the sum of the gages from the back of the angles less the thickness.

For splice members, the thickness shall be only that part of the thickness of the member that has been developed by rivets or bolts, beyond the section considered.

**2010.1.7 Effective sections of angles.** If a discontinuous angle (single or paired) in tension is connected to one side of a gusset plate, the effective net section shall be the net section of the connected leg plus one third of the section of the outstanding leg unless the outstanding leg is connected by a lug angle. In the latter case, the effective net section shall be the entire net section of the angle. The lug angle shall be designed to develop at least one half the total load in the member and shall be connected to the main member by at least two fasteners.

For double angles placed back to back and connected to both sides of a gusset plate, the effective net section shall be the net section of the connected legs plus two thirds of the section of the outstanding legs.

For intermediate joints of continuous angles, the effective net area shall be the gross sectional area less deductions for holes.

**2010.1.8 Grip of rivets and bolts.** If the grip (total thickness of metal being fastened) of rivets or bolts carrying calculated stress exceeds four and one-half times the diameter, the allowable

load per rivet or bolt shall be reduced. The reduced allowable load shall be the normal allowable load divided by  $[1/2 + G/(9D)]$  in which  $G$  is the grip and  $D$  is the nominal diameter of the rivet or bolt. If the grip of the rivet exceeds six times the diameter, special care shall be taken to insure that holes will be filled completely.

**2010.1.9 Spacing of rivets and bolts.** Minimum distance of rivet centers shall be three times the nominal rivet diameter; minimum distance of bolt centers shall be two and one-half times the nominal bolt diameter. In built-up compression members, the pitch in the direction of stress shall be such that the allowable stress on the individual outside sheets and shapes treated as columns having a length equal to the rivet or bolt pitch exceeds the calculated stress. The gage at right angles to the direction of stress shall be such that the allowable stress in the outside sheets, calculated from Specification 9 of Table 20-I-C exceeds the calculated stress. In this case the width,  $b$ , may be taken as  $0.8s$  where  $s$  is the gage in inches (mm).

**2010.1.10 Stitch rivets and bolts.** Where two or more web plates are in contact, there shall be stitch rivets or bolts to make them act in unison. In compression members, the pitch and gage of such rivets or bolts shall be determined as outlined in paragraph 9. In tension members, the maximum pitch or gage of such rivets or bolts shall not exceed a distance, in inches, equal to  $(3 + 20t)$  in which  $t$  is the thickness of the outside plates, in inches (mm).

**2010.1.11 Edge distance of rivets or bolts.** The distance from the center of rivet or bolt under computed stress to the edge of the sheet or shape toward which the pressure is directed shall be twice the nominal diameter of the rivet or bolt. When a shorter edge distance is used, the allowable bearing stress as determined by Table 20-I-C shall be reduced by the ratio: actual edge distance/twice rivet or bolt diameter. The edge distance shall not be less than 1.5 times the rivet or bolt diameter to sheared, sawed, rolled or planed edges.

**2010.1.12 Blind rivets.** Blind rivets may be used only when the grip lengths and rivethole tolerances are as recommended by the respective manufacturers.

**2010.1.13 Hollow-end rivets.** If hollow-end rivets with solid cross sections for a portion of the length are used, the strength of these rivets may be taken equal to the strength of solid rivets of the same material, provided that the bottom of the cavity is at least 25 percent of the rivet diameter from the plane of shear as measured toward the hollow end; and, further, provided that they are used in locations where they will not be subjected to appreciable tensile stresses.

**2010.1.14 Lock bolts.** Lock bolts may be used when installed in conformance with the lock bolt manufacturer's recommended practices and provided the body diameter and bearing areas under the head and nut, or their equivalent, are not less than those of a conventional nut and bolt.

**2010.2 Thread Forming (Tapping) Screws and Metal Stitching Staples.** If joints carrying calculated loads are to be made with thread-forming screws or metal stitches, allowable strength values for these connections shall be established on the basis of specific acceptable tests.

### 2010.3 Fasteners for Structural Formed Sheet Roofing and Siding.

**2010.3.1 General.** Fasteners shall have tensile and tensile anchorage strengths in resisting back loads, or uplift, in excess of the strength of the connection between fastener and sheet.

**2010.3.2 Allowable loads for fasteners.** The allowable tensile load per fastener shall be:

$$P_t = (1/2.2) \times (\text{minimum strength of connection between fastener and sheet}).$$

**2010.3.3 Allowable loads for specific fasteners.** The allowable loads for the specific fasteners listed, expressed in pounds (N), shall be used unless other allowable loads can be justified. Allowable loads for fasteners not listed shall be based on the results of tests and shall comply with the provisions of Sections 2010.3.1 and 2010.3.2 above.

1. No. 14 stainless steel alloy self-tapping screws, hex head, cadmium plated, with composite aluminum-neoprene washer, the aluminum portion of which has minimum dimensions of

0.050-inch (1.27 mm) thickness and  $\frac{5}{8}$ -inch (16 mm) OD, or with a stainless steel neoprene washer, the stainless steel portion of which has minimum dimensions of 0.038-inch (0.965 mm) (No. 20 gage) thickness and  $\frac{5}{8}$ -inch (16 mm) OD. In crowns,

$$P_t = 140t F_{ty}$$

For SI:  $\times 4.45$  for N  
and in valleys,

$$P_t = 170t F_{ty}$$

For SI:  $\times 4.45$  for N

For steel supporting members, screw holes should be made with a No. 8 drill for No. 14-gage through No. 11-gage material, a No. 4 drill for No. 10-gage up to  $\frac{3}{16}$  inch (4.76 mm) and a No. 1 drill for  $\frac{3}{16}$  inch (4.76 mm) and thicker.

2. Stainless steel alloy welded studs,  $\frac{5}{16}$ -inch-diameter (7.9 mm) base,  $\frac{3}{16}$ -inch-diameter (4.76 mm) serrated top, with field-installed swaged aluminum cap of  $\frac{1}{2}$ -inch (13 mm) diameter,

$$P_t = 230$$

For SI:  $P_t = 1023 N$

## SECTION 2011 — FABRICATION

**2011.1 Laying Out.** Hole centers may be center punched and cutoff lines may be punched or scribed. Center punching and scribing shall not be used where such marks would remain on fabricated material.

A temperature correction shall be applied where necessary in the layout of critical dimensions. The coefficient of expansion shall be taken as 0.000013 per degree Fahrenheit (0.000072 per °C.).

**2011.2 Cutting.** Material may be sheared, sawed, cut with a router or arc cut. All edges which have been cut by the arc process shall be planed to remove edge cracks.

Cut edges shall be true, smooth and free from excessive burrs or ragged breaks.

Re-entrant cuts shall be avoided wherever possible. If used, they shall be filleted by drilling prior to cutting.

Oxygen cutting of aluminum alloys shall not be permitted.

**2011.3 Heating.** Structural material shall not be heated.

**EXCEPTION:** Material may be heated to a temperature not exceeding 400°F. (204°C.) for a period not exceeding 30 minutes in order to facilitate bending. Such heating shall be done only when proper temperature controls and supervision are provided to insure that the limitations on temperature and time are carefully observed.

**2011.4 Punching, Drilling and Reaming.** The following rules for punching, drilling and reaming shall be observed:

1. Rivet or bolt holes may be either punched or drilled. Punching shall not be used if the metal thickness is greater than the diameter of the hole. The amount by which the diameter of a sub-punched hole is less than that of the finished hole shall be at least one fourth the thickness of the piece and in no case less than  $\frac{1}{32}$  inch (0.8 mm).

2. The finished diameter of holes for cold-driven rivets shall not be more than 4 percent greater than the nominal diameter of the rivet.

3. The finished diameter of holes for hot-driven rivets shall not be more than 7 percent greater than the nominal diameter of the rivet.

4. The finished diameter of holes for bolts shall not be more than  $\frac{1}{16}$  inch (1.6 mm) larger than the nominal bolt diameter.

5. If any holes must be enlarged to admit the rivets or bolts, they shall be reamed. Poor matching of holes shall be cause for rejection. Holes shall not be drifted in such a manner as to distort the metal. All chips lodged between contacting surfaces shall be removed before assembly.

#### **2011.5 Riveting.**

**2011.5.1 Driven head.** The driven head of aluminum alloy rivets shall be of the flat or the cone-point type with dimensions as follows:

1. Flat heads shall have a diameter not less than 1.4 times the nominal rivet diameter and a height not less than 0.4 times the nominal rivet diameter.

2. Cone-point heads shall have a diameter not less than 1.4 times the nominal rivet diameter and a height to the apex of the cone not less than 0.65 times the nominal rivet diameter. The included angle at the apex of the cone shall be approximately 127 degrees.

**2011.5.2 Hole filling.** Rivets shall fill holes completely. Rivet heads shall be concentric with the rivet holes and shall be in proper contact with the surface of the metal.

**2011.5.3 Defective rivets.** Defective rivets shall be removed by drilling.

#### **2011.6 Painting.**

**2011.6.1 General.** Structures of the alloys covered by these standards are not ordinarily painted (with the exception of 2014-T6 when exposed to corrosive environments). Surfaces shall be painted where:

1. The aluminum alloy parts are in contact with, or are fastened to, steel members or other dissimilar materials.

2. The structures are to be exposed to extremely corrosive conditions, or for reason of appearance. Painting procedure is covered in the following paragraphs and methods of cleaning and preparation are found in Section 2011.7. (Treatment and painting of the structure in accordance with United States Military Specification MIL-T-704 is also acceptable.)

**2011.6.2 Contact with dissimilar materials.** Where the aluminum alloy parts are in contact with, or are fastened to, steel members or other dissimilar materials, the aluminum shall be kept from direct contact with the steel or other dissimilar material by painting as follows:

1. Aluminum surfaces to be placed in contact with steel shall be given one coat of zinc chromate primer in accordance with Federal Specification TT-P-645 or the equivalent, or one coat of a suitable nonhardening joint compound capable of excluding moisture from the joint during prolonged service. Where severe corrosion conditions are expected, additional protection can be obtained by applying the joint compound in addition to the zinc chromate primer. Zinc chromate paint shall be allowed to dry hard (air dry 24 hours) before assembly of the parts. The steel surfaces to be placed in contact with aluminum shall be painted with good quality priming paint, such as zinc chromate primer in accordance with Federal Specification TT-P-645, followed by one coat of paint consisting of 2 pounds of aluminum paste pigment (ASTM Specification D 96266, Type 2, Class B) per gallon (0.24 kg/L) of varnish meeting Federal Specification TT-V-81d, Type II, or the equivalent. Stainless steel, or aluminized, hot-dip galvanized or electrogalvanized steel placed in contact with aluminum need not be painted.

2. When aluminum is in direct contact with wood, fiberboard or other porous material that may absorb water, an insulating barrier shall be installed between the aluminum and the porous material. Such aluminum surfaces shall be given a heavy coat of alkali-resistant bituminous paint or other coating providing equivalent protection before installation. Aluminum in contact with concrete or masonry shall be similarly protected in cases where moisture is present and corrodents can be entrapped between the surfaces.

3. Aluminum surfaces to be embedded in concrete ordinarily need not be painted, unless corrosive components are added to the concrete or unless the concrete is subjected for extended periods to extremely corrosive conditions. In such cases, aluminum surfaces shall be given one coat of suitable quality paint, such as zinc chromate primer conforming to Federal Specification TT-P-645 or equivalent, or shall be wrapped with a suitable plastic tape applied in such a manner as to provide adequate protection at the overlap.

4. Water that comes in contact with aluminum after first running over a heavy metal such as copper may contain trace quantities of the dissimilar metal or its corrosion product, which will cause corrosion of the aluminum. Protection shall be obtained by painting or plastic coating the dissimilar metal or by designing the structure so that the drainage from the dissimilar metal is diverted away from the aluminum.

**2011.6.3 Overall painting.** Structures of the alloys covered by this standard are either not ordinarily painted for surface protection (with the exception of 2014-T6 when exposed to corrosive environments) or are made of prepainted aluminum components. There may be applications where the structures are to be exposed to extremely corrosive conditions. In these cases overall painting shall be specified.

**2011.7 Cleaning and Treatment of Metal Surfaces.** Prior to field painting of structures, all surfaces to be painted shall be cleaned immediately before painting by a method that will remove all dirt, oil, grease, chips and other foreign substances.

Exposed metal surfaces shall be cleaned with a suitable chemical cleaner such as a solution of phosphoric acid and organic solvents meeting United States Military Specification MIL-M-10578. If the metal is more than  $1/8$  inch (3.2 mm) thick, sandblasting may be used.

## SECTION 2012 — WELDED CONSTRUCTION

**2012.1 Filler Wire.** Verification shall be provided to show that the choice of filler metal for general purpose welding is appropriate.

**2012.2 Columns and Single-web Beams with Welds at Locations Other than Ends and Cantilever Columns and Single-web Beams.** The allowable stresses determined in accordance with the provisions of Division I apply to members supported at both ends with welds at the ends only (not farther from the supports than  $0.05 L$  from the ends).

For columns with transverse welds at locations other than the supports, cantilever columns with transverse welds at or near the supported end and columns with longitudinal welds having  $A_w$  equal to or greater than 15 percent of  $A$ , the effect of welding on column strength shall be taken into account by using an increased slenderness ratio,  $L_w/r$ , in the column formula, as follows:

$$\text{If } \frac{L}{r} > \sqrt{\frac{250,000}{F_{cyw}}}; \frac{L_w}{r} = \frac{L}{r}$$

For SI: 
$$\text{If } \frac{L}{r} > \sqrt{\frac{24.4E}{F_{cyw}}}; \frac{L_w}{r} = \frac{L}{r}$$

$$\text{If } \frac{L}{r} \leq \sqrt{\frac{250,000}{F_{cyw}}};$$

For SI: 
$$\text{If } \frac{L}{r} \leq \sqrt{\frac{24.4E}{F_{cyw}}};$$

**TABLE 20-II-A—MINIMUM MECHANICAL PROPERTIES FOR ALUMINUM ALLOYS**  
 Values Are Given in Units of ksi (1,000 lb/in<sup>2</sup>)

ALLOY AND TEMPER	PRODUCT <sup>1</sup>	THICKNESS RANGE <sup>1</sup> (Inch)	TENSION		COMPRES- SION	SHEAR		BEARING		COMPRESSIVE MODULUS OF ELASTICITY <sup>3</sup>
			$F_u^2$ ksi	$F_y^2$ ksi	$F_{cy}$ ksi	$F_{su}$ ksi	$F_{sy}$ ksi	$F_{bu}$ ksi	$F_{by}$ ksi	$E$ ksi
		× 25.4 for mm	× 6.89 for MPa							
1100-H12 -H14	Sheet, plate	All	14	11	10	9	6.5	28	18	10,100
	Rolled rod and bar Drawn tube	All	16	14	13	10	8	32	21	10,100
2014-T6 -T651 -T6, -T6510 <sup>1</sup> -T6, -T651	Sheet	0.040-0.249	66	58	59	40	33	125	93	10,900
	Plate	0.250-2.000	67	59	58	40	34	127	94	10,900
	Extrusions	All	60	53	55	35	31	114	85	10,900
	Rolled rod and bar Drawn tube	All	65	55	53	38	32	124	88	10,900
Alclad 2014-T6 -T6 -T651	Sheet	0.020-0.039	63	55	56	38	32	120	88	10,800
	Sheet	0.040-0.249	64	57	58	39	33	122	91	10,800
	Plate	0.250-0.499	64	57	56	39	33	122	91	10,800
3003-H12 -H14 -H16 -H18	Sheet and plate	0.017-2.000	17	12	10	11	7	34	19	10,100
	Sheet and plate	0.009-1.000	20	17	14	12	10	40	25	10,100
	Sheet	0.006-0.162	24	21	18	14	12	46	31	10,100
	Sheet	0.006-0.128	27	24	20	15	14	49	34	10,100
3003-H12 -H14 -H16 -H18	Drawn tube	All	17	12	11	11	7	34	19	10,100
	Drawn tube	All	20	17	16	12	10	40	25	10,100
	Drawn tube	All	24	21	19	14	12	46	31	10,100
	Drawn tube	All	27	24	21	15	14	49	34	10,100
Alclad 3003-H12 -H14 -H16 -H18	Sheet and plate	0.017-2.000	16	11	9	10	6.5	32	18	10,100
	Sheet and plate	0.009-1.000	19	16	13	12	9	38	24	10,100
	Sheet	0.006-0.162	23	20	17	14	12	44	30	10,100
	Sheet	0.006-0.128	26	23	19	15	13	47	32	10,100
Alclad 3003 H14 -H18	Drawn tube	0.010-0.500	19	16	15	12	9	38	24	10,100
	Drawn Tube	0.010-0.500	26	23	20	15	13	47	32	10,100
3004-H32 -H34 -H36	Sheet and plate	0.017-2.000	28	21	18	17	12	56	36	10,100
	Sheet and plate	0.009-1.000	32	25	22	19	14	64	40	10,100
	Sheet	0.006-0.162	35	28	25	20	16	70	45	10,100

3004-H34	Drawn tube	0.018-0.450	32	25	24	19	14	64	40	10,100
-H36	Drawn tube	0.018-0.450	35	28	27	20	16	70	45	10,100
Alclad										
3004-H32	Sheet	0.017-0.249	27	20	17	16	12	54	34	10,100
-H34	Sheet	0.009-0.249	31	24	21	18	14	62	38	10,100
-H36	Sheet	0.006-0.162	34	27	24	19	16	68	43	10,100
-H14	Sheet	0.009-0.249	32	26	22	19	15	64	39	10,100
-H16	Sheet	0.006-0.050	35	30	28	20	17	66	45	10,100
-H16	Sheet	0.051-0.162	35	30	26	20	17	66	45	10,100
-H131, -H241, -H341	Sheet	0.024-0.050	31	26	22	18	15	62	39	10,100
-H151, -H261, -H361	Sheet	0.024-0.050	34	30	28	19	17	66	45	10,100
3005-H25	Sheet	0.013-0.050	26	22	20	15	13	49	35	10,100
3006-H391	Sheet	0.010-0.050	31	27	27	20	16	60	44	10,100
3105-H25	Sheet	0.013-0.080	23	19	17	14	11	44	28	10,100
5005-H12	Sheet and plate	0.018-2.000	18	14	13	11	8	34	22	10,100
-H14	Sheet and plate	0.009-1.000	21	17	15	12	10	40	25	10,100
-H16	Sheet	0.006-0.162	24	20	18	14	12	48	30	10,100
-H32	Sheet and plate	0.017-2.000	17	12	11	11	7	34	20	10,100
-H34	Sheet and plate	0.009-1.000	20	15	14	12	8.5	40	24	10,100
-H36	Sheet	0.006-0.162	23	18	16	13	11	48	29	10,100
5050-H32	Sheet	0.017-0.249	22	16	14	14	9	44	27	10,100
-H34	Sheet	0.009-0.249	25	20	18	15	12	50	32	10,100
-H32	Rolled rod and bar	All	22	16	15	13	9	44	27	10,100
-H34	Drawn tube	All	25	20	19	15	12	50	32	10,100
5052-H32	Sheet and plate	All	31	23	21	19	13	60	39	10,200
-H34	Rolled rod and bar	All	34	26	24	20	15	65	44	10,200
-H36	Drawn tube	0.006-0.162	37	29	26	22	17	70	46	10,200
5083-H111	Extrusions	up to 0.500	40	24	21	24	14	78	41	10,400
-H111	Extrusions	0.501 and over	40	24	21	23	14	78	38	10,400
-H321	Sheet and plate	0.188-1.500	44	31	26	26	18	84	53	10,400
-H323	Sheet	0.051-0.249	45	34	32	26	20	88	58	10,400
-H343	Sheet	0.051-0.249	50	39	37	29	23	95	66	10,400
-H321	Plate	1.501-3.000	41	29	24	24	17	78	49	10,400

(Continued)

**TABLE 20-II-A—MINIMUM MECHANICAL PROPERTIES FOR ALUMINUM ALLOYS—(Continued)**  
 Values Are Given in Units of ksi (1,000 lb/in<sup>2</sup>)

ALLOY AND TEMPER	PRODUCT <sup>1</sup>	THICKNESS RANGE <sup>1</sup> (inch)  × 25.4 for mm	TENSION		COMPRES- SION	SHEAR		BEARING		COMPRESSIVE MODULUS OF ELASTICITY <sup>3</sup>
			$F_{Tu}^2$ ksi	$F_{Ty}^2$ ksi	$F_{Cy}$ ksi	$F_{Sy}$ ksi	$F_{Sy}$ ksi	$F_{By}$ ksi	$F_{By}$ ksi	$E$ ksi
			× 6.89 for MPa							
5086-H111	Extrusions	up to 0.500	36	21	18	21	12	70	36	10,400
-H111	Extrusions	0.501 and over	36	21	18	21	12	70	34	10,400
-H112	Plate	0.250-0.499	36	18	17	22	10	72	31	10,400
-H112	Plate	0.500-1.000	35	16	16	21	9	70	28	10,400
-H112	Plate	1.001-2.000	35	14	15	21	8	70	28	10,400
-H112	Plate	2.001-3.000	34	14	15	21	8	68	28	10,400
-H32	Sheet and plate	All	40	28	26	24	16	78	48	10,400
-H34	Drawn tube	All	44	34	32	26	20	84	58	10,400
5154-H38	Sheet	0.006-0.128	45	35	33	24	20	81	56	10,300
5454-H111	Extrusions	up to 0.500	33	19	16	20	11	64	32	10,400
-H111	Extrusions	0.501 and over	33	19	16	19	11	64	30	10,400
-H112	Extrusions	up to 5.000	31	12	13	19	7	62	24	10,400
-H32	Sheet and plate	0.020-2.000	36	26	24	21	15	70	44	10,400
-H34	Sheet and plate	0.020-1.000	39	29	27	23	17	74	49	10,400
5456-H111	Extrusions	up to 0.500	42	26	22	25	15	82	44	10,400
-H111	Extrusions	0.501 and over	42	26	22	24	15	82	42	10,400
-H112	Extrusions	up to 5.000	41	19	20	24	11	82	38	10,400
-H321	Sheet and plate	0.188-1.250	46	33	27	27	19	87	56	10,400
-H321	Plate	1.251-1.500	44	31	25	25	18	84	53	10,400
-H321	Plate	1.501-3.000	41	29	25	25	17	82	49	10,400
-H323	Sheet	0.051-0.249	48	36	34	28	21	94	61	10,400
-H343	Sheet	0.051-0.249	53	41	39	31	24	101	70	10,400
6005-T5	Extrusions	up to 0.500	38	35	35	24	20	80	56	10,100
6061-T6, -T651	Sheet and plate	0.010-4.000	42	35	35	27	20	88	58	10,100
-T6, -T6510 <sup>1</sup>	Extrusions	up to 3.000	38	35	35	24	20	80	56	10,100
-T6, -T651	Rolled rod and bar	up to 8.000	42	35	35	27	20	88	56	10,100
-T6	Drawn tube	0.025-0.500	42	35	35	27	20	88	56	10,100
-T6	Pipe	up to 0.999	42	35	35	27	20	88	56	10,100
-T6	Pipe	over 0.999	38	35	35	24	20	80	56	10,100

6063-T5 -T5 -T6	Extrusions	up to 0.500	22	16	16	13	9	46	26	10,100
	Extrusions	over 0.500	21	15	15	12	8.5	44	24	10,100
	Extrusions Pipe	All	30	25	25	19	14	63	40	10,100
6351-T5	Extrusions	up to 1.00	38	35	35	24	20	80	56	10,100

<sup>1</sup>Values also apply to -T6511 temper.

<sup>2</sup> $F_{tu}$  and  $F_{ty}$  are minimum specified values (except for Alclad 3004-H14, -H16 and  $F_{ty}$  for Alclad 3003-H18). Other strength properties are corresponding minimum expected values.

<sup>3</sup>For deflection calculations an average modulus of elasticity is used; numerically this is 100 ksi (689 MPa) lower than the values in this column.

**TABLE 20-II-B—MINIMUM MECHANICAL PROPERTIES FOR WELDED ALUMINUM ALLOYS<sup>1</sup>**  
(Gas Tungsten Arc or Gas Metal Arc Welding with No Postweld Heat Treatment)

ALLOY AND TEMPER	PRODUCT AND THICKNESS RANGE (inch) × 25.4 for mm	TENSION		COMPRES- SION	SHEAR		BEARING	
		$F_{tu}$ <sup>1</sup> ksi	$F_{ty}$ <sup>2</sup> ksi	$F_{cy}$ <sup>2</sup> ksi	$F_{suw}$ ksi	$F_{svw}$ ksi	$F_{buw}$ ksi	$F_{bv}$ ksi
		× 6.89 for MPa						
1100-H12, -H14	All	11	4.5	4.5	8	2.5	23	8
3003-H12, -H14, -H16, -H18	All	14	7	7	10	4	30	12
Alclad 3003-H12, -H14, -H16, -H18	All	13	6	6	10	3.5	30	11
3004-H32, -H34, -H36	All	22	11	11	14	6.5	46	20
Alclad 3004-H32, -H34, -H14, -H16	All	21	11	11	13	6.5	44	19
3005-H25	Sheet 0.013-0.050	17	9	9	12	5	36	15
5005-H12, -H14, -H32, -H34	All	14	7	7	9	4	28	10
5050-H32, -H34	All	18	8	8	12	4.5	36	12
5052-H32, -H34	All	25	13	13	16	7.5	50	19
5083-H111	Extrusions	39	21	20	23	12	78	32
-H321	Sheet and plate 0.188-1.500	40	24	24	24	14	80	36
-H321	Plate 1.501-3.000	39	23	23	24	13	78	34
-H323, -H343	Sheet	40	24	24	24	14	80	36

(Continued)

**TABLE 20-II-B—MINIMUM MECHANICAL PROPERTIES FOR WELDED ALUMINUM ALLOYS<sup>1</sup>—(Continued)**  
**(Gas Tungsten Arc or Gas Metal Arc Welding with No Postweld Heat Treatment)**

ALLOY AND TEMPER	PRODUCT AND THICKNESS RANGE (Inch) × 25.4 for mm	TENSION		COMPRES- SION	SHEAR		BEARING	
		$F_{Tuw}^1$ ksi	$F_{Dw}^2$ ksi	$F_{Cw}^2$ ksi	$F_{Suw}$ ksi	$F_{Dw}$ ksi	$F_{Buw}$ ksi	$F_{Dw}$ ksi
		× 6.89 for MPa						
5086-H111	Extrusions	35	18	17	21	10	70	28
-H112	Plate 0.250-0.499	35	17	17	21	9.5	70	28
-H112	Plate 0.500-1.000	35	16	16	21	9	70	28
-H112	Plate 1.001-2.000	35	14	14	21	8	70	28
-H32, -H34	Sheet and plate	35	19	19	21	11	70	28
5086-H111	Extrusions	35	18	17	21	10	70	28
-H112	Plate 0.250-0.499	35	17	17	21	9.5	70	28
-H112	Plate 0.500-1.000	35	16	16	21	9	70	28
-H112	Plate 1.001-2.000	35	14	14	21	8	70	28
-H32, -H34	Sheet and plate	35	19	19	21	11	70	28
5154-H38	Sheet	30	15	15	19	8.5	60	23
5454-H111	Extrusions	31	16	15	19	9.5	62	24
-H112	Extrusions	31	12	12	19	7	62	24
-H32, -H34	Sheet and plate	31	16	16	19	9.5	62	24
5456-H111	Extrusions	41	24	22	24	14	82	38
-H112	Extrusions	41	19	19	24	11	82	38
-H321	Sheet and plate 0.188-1.500	42	26	24	25	15	84	38
-H321	Plate 1.501-3.000	41	24	23	25	14	82	36
-H323, -H343	Sheet	42	26	26	25	15	84	38
6005-T5	Extrusions Up to 0.250	24	17	17	15	10	50	30
6061-T6, -T651 <sup>3</sup>	All	24	20	20	15	12	50	30
-T6, -T651 <sup>4</sup>	Over 0.375	24	15	15	15	9	50	30
6063-T5, -T6	All	17	11	11	11	6.5	34	22
6351-T5 <sup>1</sup>	Extrusions	24	20	20	15	12	50	30
-T5 <sup>4</sup>	Over 0.375	24	15	15	15	9	50	30

<sup>1</sup>Values of  $F_{Tuw}$  are ASME weld qualification test values.

<sup>2</sup>0.2 percent offset in 10-inch (254 mm) gauge length across a butt weld.

<sup>3</sup>Values when welded with 5183, 5356 or 5556 alloy filler wire regardless of thickness. Values also apply to thicknesses less than 0.375 inch (9.5 mm) when welded with 4043, 5154, 5254 or 5554 alloy filler wire.

<sup>4</sup>Values when welded with 4043, 5154, 5254 or 5554 alloy filler wire.

## Chapter 21 MASONRY

**NOTE: This chapter has been reformatted in its entirety.**

### SECTION 2101 — GENERAL

**2101.1 Scope.** The materials, design, construction and quality control of masonry shall be in accordance with this chapter.

**2101.2 Design Methods.** Masonry shall comply with the provisions of one of the following design methods in this chapter as well as the requirements of Sections 2101 through 2105.

**2101.2.1 Working stress design.** Masonry designed by the working stress design method shall comply with the provisions of Sections 2106 and 2107.

**2101.2.2 Strength design.** Masonry designed by the strength design method shall comply with the provisions of Sections 2106 and 2108.

**2101.2.3 Empirical design.** Masonry designed by the empirical design method shall comply with the provisions of Sections 2106 and 2109.

**2101.2.4 Glass masonry.** Glass masonry shall comply with the provisions of Section 2110.

**2101.3 Definitions.** For the purpose of this chapter, certain terms are defined as follows:

#### AREAS:

**Bedded Area** is the area of the surface of a masonry unit which is in contact with mortar in the plane of the joint.

**Effective Area of Reinforcement** is the cross-sectional area of reinforcement multiplied by the cosine of the angle between the reinforcement and the direction for which effective area is to be determined.

**Gross Area** is the total cross-sectional area of a specified section.

**Net Area** is the gross cross-sectional area minus the area of ungrouted cores, notches, cells and unbedded areas. Net area is the actual surface area of a cross section of masonry.

**Transformed Area** is the equivalent area of one material to a second based on the ratio of moduli of elasticity of the first material to the second.

#### BOND:

**Adhesion Bond** is the adhesion between masonry units and mortar or grout.

**Reinforcing Bond** is the adhesion between steel reinforcement and mortar or grout.

**BOND BEAM** is a horizontal grouted element within masonry in which reinforcement is embedded.

**CELL** is a void space having a gross cross-sectional area greater than 1<sup>1</sup>/<sub>2</sub> square inches (967 mm<sup>2</sup>).

**CLEANOUT** is an opening to the bottom of a grout space of sufficient size and spacing to allow the removal of debris.

**COLLAR JOINT** is the vertical, longitudinal, mortar or grouted joint between wythes.

**COLUMN, REINFORCED,** is a vertical structural member in which both the steel and masonry resist compression.

**COLUMN, UNREINFORCED,** is a vertical structural member whose horizontal dimension measured at right angles to the thickness does not exceed three times the thickness.

**DIMENSIONS:**

**Actual Dimensions** are the measured dimensions of a designated item. The actual dimension shall not vary from the specified dimension by more than the amount allowed in the appropriate standard of quality in Section 2102.

**Nominal Dimensions** of masonry units are equal to its specified dimensions plus the thickness of the joint with which the unit is laid.

**Specified Dimensions** are the dimensions specified for the manufacture or construction of masonry, masonry units, joints or any other component of a structure.

**GROUT LIFT** is an increment of grout height within the total pour; a pour may consist of one or more grout lifts.

**GROUT POUR** is the total height of masonry wall to be grouted prior to the erection of additional masonry. A grout pour will consist of one or more grout lifts.

**GROUTED MASONRY:**

**Grouted Hollow-unit Masonry** is that form of grouted masonry construction in which certain designated cells of hollow units are continuously filled with grout.

**Grouted Multiwythe Masonry** is that form of grouted masonry construction in which the space between the wythes is solidly or periodically filled with grout.

**JOINTS:**

**Bed Joint** is the mortar joint that is horizontal at the time the masonry units are placed.

**Collar Joint** is the vertical, longitudinal, mortar or grouted joint.

**Head Joint** is the mortar joint having a vertical transverse plane.

**MASONRY UNIT** is brick, tile, stone, glass block or concrete block conforming to the requirements specified in Section 2102.

**Hollow-masonry Unit** is a masonry unit whose net cross-sectional area in every plane parallel to the bearing surface is less than 75 percent of the gross cross-sectional area in the same plane.

**Solid-masonry Unit** is a masonry unit whose net cross-sectional area in every plane parallel to the bearing surface is 75 percent or more of the gross cross-sectional area in the same plane.

**PRISM** is an assemblage of masonry units and mortar with or without grout used as a test specimen for determining properties of the masonry.

**REINFORCED MASONRY** is that form of masonry construction in which reinforcement acting in conjunction with the masonry is used to resist forces.

**SHELL** is the outer portion of a hollow masonry unit as placed in masonry.

**WALLS:**

**Bonded Wall** is a masonry wall in which two or more wythes are bonded to act as a structural unit.

**Cavity Wall** is a wall containing continuous air space with a minimum width of 2 inches (51 mm) and a maximum width of 4<sup>1</sup>/<sub>2</sub> inches (114 mm) between wythes which are tied with metal ties.

**WALL TIE** is a mechanical metal fastener which connects wythes of masonry to each other or to other materials.

**WEB** is an interior solid portion of a hollow-masonry unit as placed in masonry.

**WYTHER** is the portion of a wall which is one masonry unit in thickness. A collar joint is not considered a wythe.

**2101.4 Notations.**

$A_b$  = cross-sectional area of anchor bolt, square inches ( $\text{mm}^2$ ).

- $A_e$  = effective area of masonry.  
 $A_g$  = gross area of wall.  
 $A_{jh}$  = total area of special horizontal reinforcement through a wall frame joint, square inches (mm<sup>2</sup>).  
 $A_{mv}$  = net area of masonry section bounded by wall thickness and length of section in the direction of shear force considered, square inches (mm<sup>2</sup>).  
 $A_p$  = area of tension (pullout) cone of an embedded anchor bolt projected onto the surface of masonry, square inches (mm<sup>2</sup>).  
 $A_s$  = effective cross-sectional area of reinforcement in a column or flexural member.  
 $A_{se}$  = effective area of steel, square inches (mm<sup>2</sup>).  
 $A_{sh}$  = total cross-sectional area of rectangular tie reinforcement for the confined core.  
 $A_v$  = area of steel required for shear reinforcement perpendicular to the longitudinal reinforcement.  
 $A'_s$  = effective cross-sectional area of compression reinforcement in a flexural member.  
 $a$  = depth of equivalent rectangular stress block for strength design.  
 $B_{sn}$  = nominal shear strength of an anchor bolt, pounds (N).  
 $B_t$  = allowable tension force on anchor bolts, pounds (N).  
 $B_m$  = nominal tensile strength of an anchor bolt, pounds (N).  
 $B_v$  = allowable shear force on anchor bolts, pounds (N).  
 $b$  = effective width of rectangular member or width of flange for  $T$  and  $I$  sections.  
 $b_{su}$  = factored shear force supported by an anchor bolt, pounds (N).  
 $b_t$  = computed tension force on anchor bolts, pounds (N).  
 $b_{tu}$  = factored tensile force supported by an anchor bolt, pounds (N).  
 $b_v$  = computed shear force on anchor bolts, pounds (N).  
 $b'$  = width of web in  $T$  and  $I$  member.  
 $C_d$  = masonry shear strength coefficient as obtained from Table 21-K.  
 $c$  = distance from the neutral axis to extreme fiber.  
 $D$  = dead loads, or related internal moments and forces.  
 $d$  = distance from the compression face of a flexural member to the centroid of longitudinal tensile reinforcement.  
 $d_b$  = diameter of the reinforcing bar.  
 $d_{bh}$  = diameter of largest beam longitudinal reinforcing bar passing through, or anchored in, the joint, inches (mm).  
 $d_{bp}$  = diameter of largest pier longitudinal reinforcing bar passing through the joint, inches (mm).  
 $E$  = load effects of earthquake, or related internal moments and forces.  
 $E_m$  = modulus of elasticity of masonry.  
 $E_s$  = modulus of elasticity of steel, 29,000,000 psi (200 GPa).  
 $e$  = eccentricity of  $P_{uf}$ .  
 $e_{mu}$  = maximum useable compressive strain of masonry.  
 $F$  = loads due to weight and pressure of fluids or related moments and forces.  
 $F_a$  = allowable average axial compressive stress for centroidally applied axial load only.  
 $F_b$  = allowable flexural compressive stress if members were carrying bending load only.  
 $F_{br}$  = allowable bearing stress.

- $F_s$  = allowable stress in reinforcement.  
 $F_{sc}$  = allowable compressive stress in column reinforcement.  
 $F_t$  = allowable flexural tensile stress in masonry.  
 $F_v$  = allowable shear stress in masonry.  
 $f_a$  = computed axial compressive stress due to design axial load.  
 $f_b$  = computed flexural stress in the extreme fiber due to design bending loads only.  
 $f_{md}$  = computed compressive stress in masonry due to dead load only.  
 $f_r$  = modulus of rupture.  
 $f_s$  = computed stress in reinforcement due to design loads.  
 $f_v$  = computed shear stress due to design load.  
 $f_y$  = tensile yield stress of reinforcement.  
 $f'_g$  = specified compressive strength of grout at the age of 28 days.  
 $f'_m$  = specified compressive strength of masonry at the age of 28 days.  
 $G$  = shear modulus of masonry.  
 $H$  = loads due to weight and pressure of soil, water in soil or related internal moments and forces.  
 $h$  = height of wall between points of support.  
 $h_b$  = beam depth, inches (mm).  
 $h_c$  = cross-sectional dimension of grouted core measured center to center of confining reinforcement.  
 $h_p$  = pier depth in the plane of the wall frame, inches (mm).  
 $h'$  = effective height of a wall or column.  
 $I$  = moment of inertia about the neutral axis of the cross-sectional area.  
 $I_e$  = effective moment of inertia.  
 $I_g, I_{cr}$  = gross, cracked moment of inertia of the wall cross section.  
 $j$  = ratio or distance between centroid of flexural compressive forces and centroid of tensile forces to depth,  $d$ .  
 $K$  = the reinforcement cover or the clear spacing, whichever is less.  
 $k$  = the ratio of depth of the compressive stress in a flexural member to the depth,  $d$ .  
 $L$  = live loads, or related internal moments and forces.  
 $L_w$  = length of wall.  
 $l$  = length of a wall or segment.  
 $l_b$  = embedment depth of anchor bolts, inches (mm).  
 $l_{be}$  = anchor bolt edge distance, the least length measured from the edge of masonry to the surface of the anchor bolt, inches (mm).  
 $l_d$  = required development length of reinforcement.  
 $M$  = design moment.  
 $M_a$  = maximum moment in the member at the stage deflection is computed.  
 $M_c$  = moment capacity of compression steel in a flexural member about the centroid of the tensile force.  
 $M_{cr}$  = nominal cracking moment strength.  
 $M_m$  = the moment of the compressive force in the masonry about the centroid of the tensile force in the reinforcement.  
 $M_n$  = nominal moment strength.

- $M_s$  = the moment of the tensile force in the reinforcement about the centroid of the compressive force in the masonry.  
 $M_{ser}$  = service moment at the midheight of the panel, including  $P\Delta$  effects.  
 $M_u$  = factored moment.  
 $n$  = modular ratio  
     =  $E_s / E_m$ .  
 $P$  = design axial load.  
 $P_a$  = allowable centroidal axial load for reinforced masonry columns.  
 $P_b$  = nominal balanced design axial strength.  
 $P_f$  = load from tributary floor or roof area.  
 $P_n$  = nominal axial strength, pounds (N).  
 $P_o$  = nominal axial load strength without bending, pounds (N).  
 $P_u$  = factored axial load, pounds (N).  
 $P_{uf}$  = factored load from tributary floor or roof loads.  
 $P_{uw}$  = factored weight of the wall tributary to the section under consideration.  
 $P_w$  = weight of the wall tributary to section under consideration.  
 $r$  = radius of gyration (based on specified unit dimensions or Tables 21-H-1, 21-H-2 and 21-H-3), inches (mm).  
 $r_b$  = ratio of the area of bars cut off to the total area of bars at the section.  
 $S$  = section modulus.  
 $s$  = spacing of stirrups or of bent bars in a direction parallel to that of the main reinforcement.  
 $T$  = effects of temperature, creep, shrinkage and differential settlement.  
 $t$  = effective thickness of a wythe, wall or column.  
 $U$  = required strength to resist factored loads, or related internal moments and forces.  
 $u$  = bond stress per unit of surface area of bar.  
 $V$  = total design shear force.  
 $V_{jh}$  = total horizontal joint shear, calculated in accordance with Section 2108.2.6.2.9, Item 1.  
 $V_m$  = nominal shear strength provided by masonry, pounds (N).  
 $V_n$  = nominal shear strength, pounds (N).  
 $V_s$  = nominal shear strength provided by shear reinforcement, pounds (N).  
 $W$  = wind load, or related internal moments in forces.  
 $w_u$  = factored distributed lateral load.  
 $\Delta_x$  = horizontal deflection at midheight under factored load.  
 $\rho$  = ratio of the area of flexural tensile reinforcement,  $A_s$ , to the area  $bd$ .  
 $\rho_n$  = ratio of distributed shear reinforcement on a plane perpendicular to plane of  $A_{mv}$ .  
 $\Sigma_v$  = sum of the perimeters of all the longitudinal reinforcement.  
 $\phi$  = strength-reduction factor.

## SECTION 2102 — MATERIAL STANDARDS

**2102.1 Quality.** Materials used in masonry shall conform to the requirements stated herein. If no requirements are specified in this section for a material, quality shall be based on generally accepted good practice, subject to the approval of the building official.

Reclaimed or previously used masonry units shall meet the applicable requirements as for new masonry units of the same material for their intended use.

**2102.2 Standards of Quality.** The standards listed below labeled a "U.B.C. standard" are also listed in Chapter 35, Part II, and are part of this code. The other standards listed below are recognized standards. See Sections 3502 and 3503.

**1. Aggregates.**

- 1.1 ASTM C 144, Aggregates for Masonry Mortar
- 1.2 ASTM C 404, Aggregates for Grout

**2. Cement.**

- 2.1 U.B.C. Standard 21-11, Masonry Cement. (Plastic cement conforming to the requirements of U.B.C. Standard 25-1 may be used in lieu of masonry cement when it also conforms to U.B.C. Standard 21-11.)
- 2.2 U.B.C. Standard 19-1, Portland Cement and Blended Hydraulic Cements
- 2.3 U.B.C. Standard 21-14, Mortar Cement

**3. Lime.**

- 3.1 U.B.C. Standard 21-12, Quick Lime for Structural Purposes
- 3.2 U.B.C. Standard 21-13, Hydrated Lime for Masonry Purposes. When Types N and NA hydrated lime are used in masonry mortar, they shall comply with the provisions of U.B.C. Standard 21-15, Section 21.1506.7, excluding the plasticity requirement.

**4. Masonry units of clay or shale.**

- 4.1 ASTM C 34 and C 112, Method C, Structural Clay Load-bearing Wall Tile
- 4.2 ASTM C 56, Structural Clay Nonload-bearing Tile
- 4.3 U.B.C. Standard 21-1, Section 21.101, Building Brick (solid units)
- 4.4 ASTM C 126, Ceramic Glazed Structural Clay Facing Tile, Facing Brick and Solid Masonry Units. Load-bearing glazed brick shall conform to the weathering and structural requirements of U.B.C. Standard 21-1, Section 21.106, Facing Brick
- 4.5 ASTM C 34 and C 112, Method C, Structural Clay Facing Tile
- 4.6 U.B.C. Standard 21-1, Section 21.106, Facing Brick (solid units)
- 4.7 U.B.C. Standard 21-1, Section 21.107, Hollow Brick
- 4.8 ASTM C 67, Sampling and Testing Brick
- 4.9 ASTM C 212, Structural Clay Facing Tile
- 4.10 ASTM C 530, Structural Clay Non-Loadbearing Screen Tile

**5. Masonry units of concrete.**

- 5.1 U.B.C. Standard 21-3, Concrete Building Brick
- 5.2 U.B.C. Standard 21-4, Hollow and Solid Load-bearing Concrete Masonry Units
- 5.3 U.B.C. Standard 21-5, Nonload-bearing Concrete Masonry Units
- 5.4 ASTM C 140, Sampling and Testing Concrete Masonry Units
- 5.5 ASTM C 426, Standard Test Method for Drying Shrinkage of Concrete Block

**6. Masonry units of other materials.**

- 6.1 **Calcium silicate.**  
U.B.C. Standard 21-2, Calcium Silicate Face Brick (Sand-lime Brick)
- 6.2 U.B.C. Standard 21-9, Unburned Clay Masonry Units

6.3 ACI-704, Cast Stone

6.4 U.B.C. Standard 21-17, Test Method for Compressive Strength of Masonry Prisms

#### 7. Connectors.

7.1 Wall ties and anchors made from steel wire shall conform to U.B.C. Standard 21-10, Part II, and other steel wall ties and anchors shall conform to A 36 in accordance with U.B.C. Standard 22-1. Wall ties and anchors made from copper, brass or other nonferrous metal shall have a minimum tensile yield strength of 30,000 psi (207 MPa).

7.2 All such items not fully embedded in mortar or grout shall either be corrosion resistant or shall be coated after fabrication with copper, zinc or a metal having at least equivalent corrosion-resistant properties.

#### 8. Mortar.

8.1 U.B.C. Standard 21-15, Mortar for Unit Masonry

8.2 U.B.C. Standard 21-16, Field Test Specimens for Mortar

8.3 U.B.C. Standard 21-20, Standard Test Method for Flexural Bond Strength of Mortar Cement

#### 9. Grout.

9.1 U.B.C. Standard 21-19, Grout for Masonry

9.2 U.B.C. Standard 21-18, Method of Sampling and Testing Grout

#### 10. Reinforcement.

10.1 U.B.C. Standard 21-10, Part I, Joint Reinforcement for Masonry

10.2 ASTM A 615, A 616, A 617, A 706, A 767, and A 775, Deformed and Plain Billet-steel Bars, Rail-steel Deformed and Plain Bars, Axle-steel Deformed and Plain Bars, and Deformed Low-alloy Bars for Concrete Reinforcement

10.3 U.B.C. Standard 21-10, Part II, Cold-drawn Steel Wire for Concrete Reinforcement

### SECTION 2103 — MORTAR AND GROUT

**2103.1 General.** Mortar and grout shall comply with the provisions of this section. Special mortars, grouts or bonding systems may be used, subject to satisfactory evidence of their capabilities when approved by the building official.

**2103.2 Materials.** Materials used as ingredients in mortar and grout shall conform to the applicable requirements in Section 2102. Cementitious materials for grout shall be one or both of the following: lime and portland cement. Cementitious materials for mortar shall be one or more of the following: lime, masonry cement, portland cement and mortar cement. Cementitious materials or additives shall not contain epoxy resins and derivatives, phenols, asbestos fibers or fireclays.

Water used in mortar or grout shall be clean and free of deleterious amounts of acid, alkalis or organic material or other harmful substances.

#### 2103.3 Mortar.

**2103.3.1 General.** Mortar shall consist of a mixture of cementitious materials and aggregate to which sufficient water and approved additives, if any, have been added to achieve a workable, plastic consistency.

**2103.3.2 Selecting proportions.** Mortar with specified proportions of ingredients that differ from the mortar proportions of Table 21-A may be approved for use when it is demonstrated by laboratory or field experience that this mortar with the specified proportions of ingredients, when

combined with the masonry units to be used in the structure, will achieve the specified compressive strength  $f'_m$ . Water content shall be adjusted to provide proper workability under existing field conditions. When the proportion of ingredients is not specified, the proportions by mortar type shall be used as given in Table 21-A.

#### 2103.4 Grout.

**2103.4.1 General.** Grout shall consist of a mixture of cementitious materials and aggregate to which water has been added such that the mixture will flow without segregation of the constituents. Grout shall have a minimum compressive strength  $f'_g$  of 2,000 pounds per square inch (14.0 MPa).

**2103.4.2 Selecting proportions.** Water content shall be adjusted to provide proper workability and to enable proper placement under existing field conditions, without segregation. Grout shall be specified by one of the following methods:

1. Proportions of ingredients and any additives shall be based on laboratory or field experience with the grout ingredients and the masonry units to be used. The grout shall be specified by the proportion of its constituents in terms of parts by volume, or
2. Minimum compressive strength which will produce the required prism strength, or
3. Proportions by grout type shall be used as given in Table 21-B.

#### 2103.5 Additives and Admixtures.

**2103.5.1 General.** Additives and admixtures to mortar or grout shall not be used unless approved by the building official.

**2103.5.2 Antifreeze compounds.** Antifreeze liquids, chloride salts or other such substances shall not be used in mortar or grout.

**2103.5.3 Air entrainment.** Air-entraining substances shall not be used in mortar or grout unless tests are conducted to determine compliance with the requirements of this code.

**2103.5.4 Colors.** Only pure mineral oxide, carbon black or synthetic colors may be used. Carbon black shall be limited to a maximum of 3 percent of the weight of the cement.

## SECTION 2104 — CONSTRUCTION

**2104.1 General.** Masonry shall be constructed according to the provisions of this section.

**2104.2 Materials: Handling, Storage and Preparation.** All materials shall comply with applicable requirements of Section 2102. Storage, handling and preparation at the site shall conform also to the following:

1. Masonry materials shall be stored so that at the time of use the materials are clean and structurally suitable for the intended use.
2. All metal reinforcement shall be free from loose rust and other coatings that would inhibit reinforcing bond.
3. At the time of laying, burned clay units and sand lime units shall have an initial rate of absorption not exceeding 0.035 ounce per square inch (1.6 L/m<sup>2</sup>) during a period of one minute. In the absorption test, the surface of the unit shall be held  $\frac{1}{8}$  inch (3 mm) below the surface of the water.
4. Concrete masonry units shall not be wetted unless otherwise approved.
5. Materials shall be stored in a manner such that deterioration or intrusion of foreign materials is prevented and that the material will be capable of meeting applicable requirements at the time of mixing.
6. The method of measuring materials for mortar and grout shall be such that proportions of the materials can be controlled.

7. Mortar or grout mixed at the jobsite shall be mixed for a period of time not less than three minutes or more than 10 minutes in a mechanical mixer with the amount of water required to provide the desired workability. Hand mixing of small amounts of mortar is permitted. Mortar may be retempered. Mortar or grout which has hardened or stiffened due to hydration of the cement shall not be used. In no case shall mortar be used two and one-half hours, nor grout used one and one-half hours, after the initial mixing water has been added to the dry ingredients at the jobsite.

**EXCEPTION:** Dry mixes for mortar and grout which are blended in the factory and mixed at the jobsite shall be mixed in mechanical mixers until workable, but not to exceed 10 minutes.

### 2104.3 Cold-weather Construction.

**2104.3.1 General.** All materials shall be delivered in a usable condition and stored to prevent wetting by capillary action, rain and snow.

The tops of all walls not enclosed or sheltered shall be covered with a strong weather-resistive material at the end of each day or shutdown.

Partially completed walls shall be covered at all times when work is not in progress. Covers shall be draped over the wall and extend a minimum of 2 feet (600 mm) down both sides and shall be securely held in place, except when additional protection is required in Section 2104.3.4.

**2104.3.2 Preparation.** If ice or snow has inadvertently formed on a masonry bed, it shall be thawed by application of heat carefully applied until top surface of the masonry is dry to the touch.

A section of masonry deemed frozen and damaged shall be removed before continuing construction of that section.

**2104.3.3 Construction.** Masonry units shall be dry at time of placement. Wet or frozen masonry units shall not be laid.

Special requirements for various temperature ranges are as follows:

1. Air temperature 40°F. to 32°F. (4.5°C. to 0°C.): Sand or mixing water shall be heated to produce mortar temperatures between 40°F. and 120°F. (4.5°C. and 49°C.).

2. Air temperature 32°F. to 25°F. (0°C. to -4°C.): Sand and mixing water shall be heated to produce mortar temperatures between 40°F. and 120°F. (4.5°C. and 49°C.). Maintain temperatures of mortar on boards above freezing.

3. Air temperature 25°F. to 20°F. (-4°C. to -7°C.): Sand and mixing water shall be heated to produce mortar temperatures between 40°F. and 120°F. (4.5°C. and 49°C.). Maintain mortar temperatures on boards above freezing. Salamanders or other sources of heat shall be used on both sides of walls under construction. Windbreaks shall be employed when wind is in excess of 15 miles per hour (24 km/h).

4. Air temperature 20°F. (-7°C.) and below: Sand and mixing water shall be heated to provide mortar temperatures between 40°F. and 120°F. (4.5°C. and 49°C.). Enclosure and auxiliary heat shall be provided to maintain air temperature above 32°F. (0°C.). Temperature of units when laid shall not be less than 20°F. (-7°C.).

**2104.3.4 Protection.** When the mean daily air temperature is 40°F. to 32°F. (4.5°C. to 0°C.), masonry shall be protected from rain or snow for 24 hours by covering with a weather-resistive membrane.

When the mean daily air temperature is 32°F. to 25°F. (0°C. to -4°C.), masonry shall be completely covered with a weather-resistive membrane for 24 hours.

When the mean daily air temperature is 25°F. to 20°F. (-4°C. to -7°C.), masonry shall be completely covered with insulating blankets or equally protected for 24 hours.

When the mean daily air temperature is 20°F. (-7°C.) and below, masonry temperature shall be maintained above 32°F. (0°C.) for 24 hours by enclosure and supplementary heat, by electric heating blankets, infrared heat lamps or other approved methods.

**2104.3.5 Placing grout and protection of grouted masonry.** When air temperatures fall below 40°F. (4.5°C.), grout mixing water and aggregate shall be heated to produce grout temperatures between 40°F. and 120°F. (4.5°C. and 49°C.).

Masonry to be grouted shall be maintained above freezing during grout placement and for at least 24 hours after placement.

When atmospheric temperatures fall below 20°F. (–7°C.), enclosures shall be provided around the masonry during grout placement and for at least 24 hours after placement.

#### **2104.4 Placing Masonry Units.**

**2104.4.1 Mortar.** The mortar shall be sufficiently plastic and units shall be placed with sufficient pressure to extrude mortar from the joint and produce a tight joint. Deep furrowing which produces voids shall not be used.

The initial bed joint thickness shall not be less than  $\frac{1}{4}$  inch (6 mm) or more than 1 inch (25 mm); subsequent bed joints shall not be less than  $\frac{1}{4}$  inch (6 mm) or more than  $\frac{5}{8}$  inch (16 mm) in thickness.

**2104.4.2 Surfaces.** Surfaces to be in contact with mortar or grout shall be clean and free of deleterious materials.

**2104.4.3 Solid masonry units.** Solid masonry units shall have full head and bed joints.

**2104.4.4 Hollow-masonry units.** All head and bed joints shall be filled solidly with mortar for a distance in from the face of the unit not less than the thickness of the shell.

Head joints of open-end units with beveled ends that are to be fully grouted need not be mortared. The beveled ends shall form a grout key which permits grout within  $\frac{5}{8}$  inch (16 mm) of the face of the unit. The units shall be tightly butted to prevent leakage of grout.

**2104.5 Reinforcement Placing.** Reinforcement details shall conform to the requirements of this chapter. Metal reinforcement shall be located in accordance with the plans and specifications. Reinforcement shall be secured against displacement prior to grouting by wire positioners or other suitable devices at intervals not exceeding 200 bar diameters.

Tolerances for the placement of reinforcement in walls and flexural elements shall be plus or minus  $\frac{1}{2}$  inch (13 mm) for  $d$  equal to 8 inches (200 mm) or less,  $\pm 1$  inch ( $\pm 25$  mm) for  $d$  equal to 24 inches (600 mm) or less but greater than 8 inches (200 mm), and  $\pm 1\frac{1}{4}$  inches (32 mm) for  $d$  greater than 24 inches (600 mm).

Tolerance for longitudinal location of reinforcement shall be  $\pm 2$  inches (51 mm).

#### **2104.6 Grouted Masonry.**

**2104.6.1 General conditions.** Grouted masonry shall be constructed in such a manner that all elements of the masonry act together as a structural element.

Prior to grouting, the grout space shall be clean so that all spaces to be filled with grout do not contain mortar projections greater than  $\frac{1}{2}$  inch (13 mm), mortar droppings or other foreign material. Grout shall be placed so that all spaces designated to be grouted shall be filled with grout and the grout shall be confined to those specific spaces.

Grout materials and water content shall be controlled to provide adequate fluidity for placement without segregation of the constituents, and shall be mixed thoroughly.

The grouting of any section of wall shall be completed in one day with no interruptions greater than one hour.

Between grout pours, a horizontal construction joint shall be formed by stopping all wythes at the same elevation and with the grout stopping a minimum of  $1\frac{1}{2}$  inches (38 mm) below a mortar joint, except at the top of the wall. Where bond beams occur, the grout pour shall be stopped a minimum of  $\frac{1}{2}$  inch (13 mm) below the top of the masonry.

Size and height limitations of the grout space or cell shall not be less than shown in Table 21-C. Higher grout pours or smaller cavity widths or cell size than shown in Table 21-C may be used when approved, if it is demonstrated that grout spaces will be properly filled.

Cleanouts shall be provided for all grout pours over 5 feet (1524 mm) in height.

Where required, cleanouts shall be provided in the bottom course at every vertical bar but shall not be spaced more than 32 inches (813 mm) on center for solidly grouted masonry. When cleanouts are required, they shall be sealed after inspection and before grouting.

Where cleanouts are not provided, special provisions must be made to keep the bottom and sides of the grout spaces, as well as the minimum total clear area as required by Table 21-C, clean and clear prior to grouting.

Units may be laid to the full height of the grout pour and grout shall be placed in a continuous pour in grout lifts not exceeding 6 feet (1830 mm). When approved, grout lifts may be greater than 6 feet (1830 mm) if it can be demonstrated the grout spaces can be properly filled.

All cells and spaces containing reinforcement shall be filled with grout.

**2104.6.2 Construction requirements.** Reinforcement shall be placed prior to grouting. Bolts shall be accurately set with templates or by approved equivalent means and held in place to prevent dislocation during grouting.

Segregation of the grout materials and damage to the masonry shall be avoided during the grouting process.

Grout shall be consolidated by mechanical vibration during placement before loss of plasticity in a manner to fill the grout space. Grout pours greater than 12 inches (300 mm) in height shall be reconsolidated by mechanical vibration to minimize voids due to water loss. Grout pours 12 inches (300 mm) or less in height shall be mechanically vibrated or puddled.

In one-story buildings having wood-frame exterior walls, foundations not over 24 inches (600 mm) high measured from the top of the footing may be constructed of hollow-masonry units laid in running bond without mortared head joints. Any standard shape unit may be used, provided the masonry units permit horizontal flow of grout to adjacent units. Grout shall be solidly poured to the full height in one lift and shall be puddled or mechanically vibrated.

In nonstructural elements which do not exceed 8 feet (2440 mm) in height above the highest point of lateral support, including fireplaces and residential chimneys, mortar of pouring consistency may be substituted for grout when the masonry is constructed and grouted in pours of 12 inches (300 mm) or less in height.

In multiwythe grouted masonry, vertical barriers of masonry shall be built across the grout space the entire height of the grout pour and spaced not more than 30 feet (9144 mm) horizontally. The grouting of any section of wall between barriers shall be completed in one day with no interruption longer than one hour.

**2104.7 Aluminum Equipment.** Grout shall not be handled nor pumped utilizing aluminum equipment unless it can be demonstrated with the materials and equipment to be used that there will be no deleterious effect on the strength of the grout.

**2104.8 Joint Reinforcement.** Wire joint reinforcement used in the design as principal reinforcement in hollow-unit construction shall be continuous between supports unless splices are made by lapping:

1. Fifty-four wire diameters in a grouted cell, or
2. Seventy-five wire diameters in the mortared bed joint, or
3. In alternate bed joints of running bond masonry a distance not less than 54 diameters plus twice the spacing of the bed joints, or

4. As required by calculation and specific location in areas of minimum stress, such as points of inflection.

Side wires shall be deformed and shall conform to U.B.C. Standard 21-10, Part I, Joint Reinforcement for Masonry.

## SECTION 2105 — QUALITY ASSURANCE

**2105.1 General.** Quality assurance shall be provided to ensure that materials, construction and workmanship are in compliance with the plans and specifications, and the applicable requirements of this chapter. When required, inspection records shall be maintained and made available to the building official.

**2105.2 Scope.** Quality assurance shall include, but is not limited to, assurance that:

1. Masonry units, reinforcement, cement, lime, aggregate and all other materials meet the requirements of the applicable standards of quality and that they are properly stored and prepared for use.

2. Mortar and grout are properly mixed using specified proportions of ingredients. The method of measuring materials for mortar and grout shall be such that proportions of materials are controlled.

3. Construction details, procedures and workmanship are in accordance with the plans and specifications.

4. Placement, splices and reinforcement sizes are in accordance with the provisions of this chapter and the plans and specifications.

### 2105.3 Compliance with $f'_m$ .

**2105.3.1 General.** Compliance with the requirements for the specified compressive strength of masonry  $f'_m$  shall be in accordance with one of the sections in this subsection.

**2105.3.2 Masonry prism testing.** The compressive strength of masonry determined in accordance with U.B.C. Standard 21-17 for each set of prisms shall equal or exceed  $f'_m$ . Compressive strength of prisms shall be based on tests at 28 days. Compressive strength at seven days or three days may be used provided a relationship between seven-day and three-day and 28-day strength has been established for the project prior to the start of construction. Verification by masonry prism testing shall meet the following:

1. A set of five masonry prisms shall be built and tested in accordance with U.B.C. Standard 21-17 prior to the start of construction. Materials used for the construction of the prisms shall be taken from those specified to be used in the project. Prisms shall be constructed under the observation of the engineer or special inspector or an approved agency and tested by an approved agency.

2. When full allowable stresses are used in design, a set of three prisms shall be built and tested during construction in accordance with U.B.C. Standard 21-17 for each 5,000 square feet (465 m<sup>2</sup>) of wall area, but not less than one set of three masonry prisms for the project.

3. When one half the allowable masonry stresses are used in design, testing during construction is not required. A letter of certification from the supplier of the materials used to verify the  $f'_m$  in accordance with Section 2105.3.2, Item 1, shall be provided at the time of, or prior to, delivery of the materials to the jobsite to assure the materials used in construction are representative of the materials used to construct the prisms prior to construction.

**2105.3.3 Masonry prism test record.** Compressive strength verification by masonry prism test records shall meet the following:

1. A masonry prism test record approved by the building official of at least 30 masonry prisms which were built and tested in accordance with U.B.C. Standard 21-17. Prisms shall have been

constructed under the observation of an engineer or special inspector or an approved agency and shall have been tested by an approved agency.

2. Masonry prisms shall be representative of the corresponding construction.
3. The average compressive strength of the test record shall equal or exceed  $1.33 f'_m$ .
4. When full allowable stresses are used in design, a set of three masonry prisms shall be built during construction in accordance with U.B.C. Standard 21-17 for each 5,000 square feet (465 m<sup>2</sup>) of wall area, but not less than one set of three prisms for the project.
5. When one half the allowable masonry stresses are used in design, field testing during construction is not required. A letter of certification from the supplier of the materials to the jobsite shall be provided at the time of, or prior to, delivery of the materials to assure the materials used in construction are representative of the materials used to develop the prism test record in accordance with Section 2105.3.3, Item 1.

**2105.3.4 Unit strength method.** Verification by the unit strength method shall meet the following:

1. When full allowable stresses are used in design, units shall be tested prior to construction and test units during construction for each 5,000 square feet (465 m<sup>2</sup>) of wall area for compressive strength to show compliance with the compressive strength required in Table 21-D; and

**EXCEPTION:** Prior to the start of construction, prism testing may be used in lieu of testing the unit strength. During construction, prism testing may also be used in lieu of testing the unit strength and the grout as required by Section 2105.3.4, Item 4.

2. When one half the allowable masonry stresses are used in design, testing is not required for the units. A letter of certification from the manufacturer of the units shall be provided at the time of, or prior to, delivery of the units to the jobsite to assure the units comply with the compressive strength required in Table 21-D; and
3. Mortar shall comply with the mortar type required in Table 21-D; and
4. When full stresses are used in design for concrete masonry, grout shall be tested for each 5,000 square feet (465 m<sup>2</sup>) of wall area, but not less than one test per project, to show compliance with the compressive strength required in Table 21-D, Footnote 4.
5. When one half the allowable stresses are used in design for concrete masonry, testing is not required for the grout. A letter of certification from the supplier of the grout shall be provided at the time of, or prior to, delivery of the grout to the jobsite to assure the grout complies with the compressive strength required in Table 21-D, Footnote 4; or
6. When full allowable stresses are used in design for clay masonry, grout proportions shall be verified by the engineer or special inspector or an approved agency to conform with Table 21-B.
7. When one half the allowable masonry stresses are used in design for clay masonry, a letter of certification from the supplier of the grout shall be provided at the time of, or prior to, delivery of the grout to the jobsite to assure the grout conforms to the proportions of Table 21-B.

**2105.3.5 Testing prisms from constructed masonry.** When approved by the building official, acceptance of masonry which does not meet the requirements of Section 2105.3.2, 2105.3.3 or 2105.3.4 shall be permitted to be based on tests of prisms cut from the masonry construction in accordance with the following:

1. A set of three masonry prisms that are at least 28 days old shall be saw cut from the masonry for each 5,000 square feet (465 m<sup>2</sup>) of the wall area that is in question but not less than one set of three masonry prisms for the project. The length, width and height dimensions of the prisms shall comply with the requirements of U.B.C. Standard 21-17. Transporting, preparation and testing of prisms shall be in accordance with U.B.C. Standard 21-17.
2. The compressive strength of prisms shall be the value calculated in accordance with U.B.C. Standard 21-17, Section 21.1707.2, except that the net cross-sectional area of the prism shall be based on the net mortar bedded area.

3. Compliance with the requirement for the specified compressive strength of masonry,  $f'_m$ , shall be considered satisfied provided the modified compressive strength equals or exceeds the specified  $f'_m$ . Additional testing of specimens cut from locations in question shall be permitted.

**2105.4 Mortar Testing.** When required, mortar shall be tested in accordance with U.B.C. Standard 21-16.

**2105.5 Grout Testing.** When required, grout shall be tested in accordance with U.B.C. Standard 21-18.

## SECTION 2106 — GENERAL DESIGN REQUIREMENTS

### 2106.1 General.

**2106.1.1 Scope.** The design of masonry structures shall comply with the working stress design provisions of Section 2107, or the strength design provisions of Section 2108 or the empirical design provisions of Section 2109, and with the provisions of this section. Unless otherwise stated, all calculations shall be made using or based on specified dimensions.

**2106.1.2 Plans.** Plans submitted for approval shall describe the required design strengths of masonry materials and inspection requirements for which all parts of the structure were designed, and any load test requirements.

**2106.1.3 Design loads.** See Chapter 16 for design loads.

**2106.1.4 Stack bond.** In bearing and nonbearing walls, except veneer walls, if less than 75 percent of the units in any transverse vertical plane lap the ends of the units below a distance less than one half the height of the unit, or less than one fourth the length of the unit, the wall shall be considered laid in stack bond.

### 2106.1.5 Multiwythe walls.

**2106.1.5.1 General.** All wythes of multiwythe walls shall be bonded by grout or tied together by corrosion-resistant wall ties or joint reinforcement conforming to the requirements of Section 2102, and as set forth in this subsection.

**2106.1.5.2 Wall ties in cavity wall construction.** Wall ties shall be of sufficient length to engage all wythes. The portion of the wall ties within the wythe shall be completely embedded in mortar or grout. The ends of the wall ties shall be bent to 90-degree angles with an extension not less than 2 inches (51 mm) long. Wall ties not completely embedded in mortar or grout between wythes shall be a single piece with each end engaged in each wythe.

There shall be at least one  $\frac{3}{16}$ -inch-diameter (9.5 mm) wall tie for each  $4\frac{1}{2}$  square feet (0.42 m<sup>2</sup>) of wall area. For cavity walls in which the width of the cavity is greater than 3 inches (75 mm), but not more than  $4\frac{1}{2}$  inches (115 mm), at least one  $\frac{3}{16}$ -inch-diameter (9.5 mm) wall tie for each 3 square feet (0.28 m<sup>2</sup>) of wall area shall be provided.

Ties in alternate courses shall be staggered. The maximum vertical distance between ties shall not exceed 24 inches (610 mm) and the maximum horizontal distance between ties shall not exceed 36 inches (914 mm).

Additional ties spaced not more than 36 inches (914 mm) apart shall be provided around openings within a distance of 12 inches (305 mm) from the edge of the opening.

Adjustable wall ties shall meet the following requirements:

1. One tie shall be provided for each 1.77 square feet (0.16 m<sup>2</sup>) of wall area. Horizontal and vertical spacing shall not exceed 16 inches (406 mm). Maximum misalignment of bed joints from one wythe to the other shall be  $1\frac{1}{4}$  inches (32 mm).

2. Maximum clearance between the connecting parts of the tie shall be  $\frac{1}{16}$  inch (1.6 mm). When used, pintle ties shall have at least two  $\frac{3}{16}$ -inch-diameter (4.8 mm) pintle legs.

Wall ties of different size and spacing that provide equivalent strength between wythes may be used.

**2106.1.5.3 Wall ties for grouted multiwythe construction.** Wythes of multiwythe walls shall be bonded together with at least  $\frac{3}{16}$ -inch-diameter (4.8 mm) steel wall tie for each 2 square feet (0.19 m<sup>2</sup>) of area. Wall ties of different size and spacing that provide equivalent strength between wythes may be used.

**2106.1.5.4 Joint reinforcement.** Prefabricated joint reinforcement for masonry walls shall have at least one cross wire of at least No. 9 gage steel for each 2 square feet (0.19 m<sup>2</sup>) of wall area. The vertical spacing of the joint reinforcement shall not exceed 16 inches (406 mm). The longitudinal wires shall be thoroughly embedded in the bed joint mortar. The joint reinforcement shall engage all wythes.

Where the space between tied wythes is solidly filled with grout or mortar, the allowable stresses and other provisions for masonry bonded walls shall apply. Where the space is not filled, tied walls shall conform to the allowable stress, lateral support, thickness (excluding cavity), height and tie requirements for cavity walls.

**2106.1.6 Vertical support.** Structural members providing vertical support of masonry shall provide a bearing surface on which the initial bed joint shall not be less than  $\frac{1}{4}$  inch (6 mm) or more than 1 inch (25 mm) in thickness and shall be of noncombustible material, except where masonry is a nonstructural decorative feature or wearing surface.

**2106.1.7 Lateral support.** Lateral support of masonry may be provided by cross walls, columns, pilasters, counterforts or buttresses where spanning horizontally or by floors, beams, girts or roofs where spanning vertically.

The clear distance between lateral supports of a beam shall not exceed 32 times the least width of the compression area.

**2106.1.8 Protection of ties and joint reinforcement.** A minimum of  $\frac{5}{8}$ -inch (16 mm) mortar cover shall be provided between ties or joint reinforcement and any exposed face. The thickness of grout or mortar between masonry units and joint reinforcement shall not be less than  $\frac{1}{4}$  inch (6 mm), except that  $\frac{1}{4}$  inch (6 mm) or smaller diameter reinforcement or bolts may be placed in bed joints which are at least twice the thickness of the reinforcement or bolts.

**2106.1.9 Pipes and conduits embedded in masonry.** Pipes or conduit shall not be embedded in any masonry in a manner that will reduce the capacity of the masonry to less than that necessary for required strength or required fire protection.

Placement of pipes or conduits in unfilled cores of hollow-unit masonry shall not be considered as embedment.

**EXCEPTIONS:** 1. Rigid electric conduits may be embedded in structural masonry when their location has been detailed on the approved plan.

2. Any pipe or conduit may pass vertically or horizontally through any masonry by means of a sleeve at least large enough to pass any hub or coupling on the pipeline. Such sleeves shall not be placed closer than three diameters, center to center, nor shall they unduly impair the strength of construction.

**2106.1.10 Load tests.** When a load test is required, the member or portion of the structure under consideration shall be subjected to a superimposed load equal to twice the design live load plus one half of the dead load. This load shall be left in position for a period of 24 hours before removal. If, during the test or upon removal of the load, the member or portion of the structure shows evidence of failure, such changes or modifications as are necessary to make the structure adequate for the rated capacity shall be made; or where approved, a lower rating shall be established. A flexural member shall be considered to have passed the test if the maximum deflection  $D$  at the end of the 24-hour period does not exceed the value of Formulas (6-1) or (6-2) and the beams and slabs show a recovery of at least 75 percent of the observed deflection within 24 hours after removal of the load.

$$D = \frac{l}{200} \quad (6-1)$$

$$D = \frac{l^2}{4,000t} \quad (6-2)$$

**2106.1.11 Reuse of masonry units.** Masonry units may be reused when clean, whole and conforming to the other requirements of this section. All structural properties of masonry of reclaimed units shall be determined by approved test.

**2106.1.12 Special provisions in areas of seismic risk.**

**2106.1.12.1 General.** Masonry structures constructed in the seismic zones shown in Figure 16-2 shall be designed in accordance with the design requirements of this chapter and the special provisions for each seismic zone given in this section.

**2106.1.12.2 Special provisions for Seismic Zones 0 and 1.** There are no special design and construction provisions in this section for structures built in Seismic Zones 0 and 1.

**2106.1.12.3 Special provisions for Seismic Zone 2.** Masonry structures in Seismic Zone 2 shall comply with the following special provisions:

1. Columns shall be reinforced as specified in Sections 2106.3.6, 2106.3.7 and 2107.2.13.
2. Vertical wall reinforcement of at least 0.20 square inch (130 mm<sup>2</sup>) in cross-sectional area shall be provided continuously from support to support at each corner, at each side of each opening, at the ends of walls and at maximum spacing of 4 feet (1219 mm) apart horizontally throughout walls.
3. Horizontal wall reinforcement not less than 0.2 square inch (130 mm<sup>2</sup>) in cross-sectional area shall be provided (1) at the bottom and top of wall openings and shall extend not less than 24 inches (610 mm) or less than 40 bar diameters past the opening, (2) continuously at structurally connected roof and floor levels and at the top of walls, (3) at the bottom of walls or in the top of foundations when doweled in walls, and (4) at maximum spacing of 10 feet (3048 mm) unless uniformly distributed joint reinforcement is provided. Reinforcement at the top and bottom of openings when continuous in walls may be used in determining the maximum spacing specified in Item 1 of this paragraph.
4. Where stack bond is used, the minimum horizontal reinforcement ratio shall be  $0.0007bt$ . This ratio shall be satisfied by uniformly distributed joint reinforcement or by horizontal reinforcement spaced not over 4 feet (1219 mm) and fully embedded in grout or mortar.
5. The following materials shall not be used as part of the vertical or lateral load-resisting systems: Type O mortar, masonry cement, plastic cement, nonloadbearing masonry units and glass block.

**2106.1.12.4 Special provisions for Seismic Zones 3 and 4.** All masonry structures built in Seismic Zones 3 and 4 shall be designed and constructed in accordance with requirements for Seismic Zone 2 and with the following additional requirements and limitations:

**EXCEPTION:** One- and two-story structures of Group R, Division 3 and Group M Occupancies in Seismic Zone 3 in which the  $h/t$  ratio of masonry walls does not exceed 27 and running bond construction is used may be constructed in accordance with the requirements of Seismic Zone 2.

1. **Column reinforcement.** The spacing of column ties shall not be more than 8 inches (203 mm) the full column height for columns stressed by tensile or compressive axial overturning forces due to the seismic loads of Part III of Chapter 16; 8 inches (203 mm) for the tops and bottoms of all other columns for a distance of one sixth of the clear column height, but not less than 18 inches (457 mm) or the maximum column dimension. Tie spacing for the remaining column height shall not exceed 16 bar diameters, 48 tie diameters, the least column dimension, nor 18 inches (457 mm).

Column ties shall terminate with a minimum 135-degree bend with a six-bar diameter, but not less than 4-inch (102 mm) extension that engages the longitudinal column reinforcement and projects into the interior of the column. Bends shall comply with Section 2107.2.2.5, Item 3.

**EXCEPTION:** Where the ties are placed in the horizontal bed joints, the hook may consist of a 90-degree bend having a radius of not less than four tie diameters plus an extension of 32 tie diameters.

## 2. Walls.

2.1 **Reinforcement.** The portion of the reinforcement required to resist shear shall be uniformly distributed and shall be joint reinforcement, deformed bars or a combination thereof. The spacing of reinforcement in each direction shall not exceed one half the length of the element, nor one half the height of the element, nor 48 inches (1219 mm).

Joint reinforcement used in exterior walls and considered in the determination of the shear strength of the member shall be hot-dipped galvanized in accordance with U.B.C. Standard 21-10.

Reinforcement required to resist in-plane shear shall be terminated with a standard hook as defined in Section 2107.2.2.5 or with an extension of proper embedment length beyond the reinforcement at the end of the wall section. The hook or extension may be turned up, down or horizontally. Provisions shall be made not to obstruct grout placement. Wall reinforcement terminating in columns or beams shall be fully anchored into these elements.

2.2 **Bond.** Multiwythe grouted masonry shear walls shall be designed with consideration of the adhesion bond strength between the grout and masonry units. When bond strengths are not known from previous tests, the bond strength shall be determined by tests.

2.3 **Wall reinforcement.** All walls shall be reinforced with both vertical and horizontal reinforcement. The sum of the areas of horizontal and vertical reinforcement shall be at least 0.002 times the gross cross-sectional area of the wall, and the minimum area of reinforcement in either direction shall not be less than 0.0007 times the gross cross-sectional area of the wall. The minimum steel requirements for Seismic Zone 2 in Section 2106.1.12.3, Items 2 and 3, may be included in the sum. The spacing of reinforcement shall not exceed 4 feet (1219 mm). The diameter of reinforcement shall not be less than  $\frac{3}{8}$  inch (9.5 mm) except that joint reinforcement may be considered as a part or all of the requirement for minimum reinforcement. Reinforcement shall be continuous around wall corners and through intersections. Only reinforcement which is continuous in the wall or element shall be considered in computing the minimum area of reinforcement. Reinforcement with splices conforming to Section 2107.2.2.6 shall be considered as continuous reinforcement.

2.4 **Stack bond.** Where stack bond is used, the minimum horizontal reinforcement ratio shall be 0.0015*bt*. Where open-end units are used and grouted solid, the minimum horizontal reinforcement ratio shall be 0.0007*bt*.

Reinforced hollow-unit stacked bond construction which is part of the seismic-resisting system shall use open-end units so that all head joints are made solid, shall use bond beam units to facilitate the flow of grout and shall be grouted solid.

3. **Type N mortar.** Type N mortar shall not be used as part of the vertical- or lateral-load-resisting system.

4. **Concrete abutting structural masonry.** Concrete abutting structural masonry, such as at starter courses or at wall intersections not designed as true separation joints, shall be roughened to a full amplitude of  $\frac{1}{16}$  inch (1.6 mm) and shall be bonded to the masonry in accordance with the requirements of this chapter as if it were masonry. Unless keys or proper reinforcement is provided, vertical joints as specified in Section 2106.1.4 shall be considered to be stack bond and the rein-

forcement as required for stack bond shall extend through the joint and be anchored into the concrete.

## **2106.2 Working Stress Design and Strength Design Requirements for Unreinforced and Reinforced Masonry.**

**2106.2.1 General.** In addition to the requirements of Section 2106.1, the design of masonry structures by the working stress design method and strength design method shall comply with the requirements of this section. Additionally, the design of reinforced masonry structures by these design methods shall comply with the requirements of Section 2106.3

**2106.2.2 Specified compressive strength of masonry.** The allowable stresses for the design of masonry shall be based on a value of  $f'_m$  selected for the construction.

Verification of the value of  $f'_m$  shall be based on compliance with Section 2105.3. Unless otherwise specified,  $f'_m$  shall be based on 28-day tests. If other than a 28-day test age is used, the value of  $f'_m$  shall be as indicated in design drawings or specifications. Design drawings shall show the value of  $f'_m$  for which each part of the structure is designed.

### **2106.2.3 Effective thickness.**

**2106.2.3.1 Single-wythe walls.** The effective thickness of single-wythe walls of either solid or hollow units is the specified thickness of the wall.

**2106.2.3.2 Multiwythe walls.** The effective thickness of multiwythe walls is the specified thickness of the wall if the space between wythes is filled with mortar or grout. For walls with an open space between wythes, the effective thickness shall be determined as for cavity walls.

**2106.2.3.3 Cavity walls.** Where both wythes of a cavity wall are axially loaded, each wythe shall be considered to act independently and the effective thickness of each wythe is as defined in Section 2106.2.3.1. Where only one wythe is axially loaded, the effective thickness of the cavity wall is taken as the square root of the sum of the squares of the specified thicknesses of the wythes.

Where a cavity wall is composed of a single wythe and a multiwythe, and both sides are axially loaded, each side of the cavity wall shall be considered to act independently and the effective thickness of each side is as defined in Sections 2106.2.3.1 and 2106.2.3.2. Where only one side is axially loaded, the effective thickness of the cavity wall is the square root of the sum of the squares of the specified thicknesses of the sides.

**2106.2.3.4 Columns.** The effective thickness for rectangular columns in the direction considered is the specified thickness. The effective thickness for nonrectangular columns is the thickness of the square column with the same moment of inertia about its axis as that about the axis considered in the actual column.

**2106.2.4 Effective height.** The effective height of columns and walls is at least the clear height of members laterally supported at the top and bottom in a direction normal to the member axis considered. For members not supported at the top normal to the axis considered, the effective height is twice the height of the member above the support. Effective height less than clear height may be used if justified.

**2106.2.5 Effective area.** The effective cross-sectional area shall be based on the minimum bedded area of hollow units, or the gross area of solid units plus any grouted area. Where hollow units are used with cells perpendicular to the direction of stress, the effective area shall be the lesser of the minimum bedded area or the minimum cross-sectional area. Where bed joints are raked, the effective area shall be correspondingly reduced. Effective areas for cavity walls shall be that of the loaded wythes.

**2106.2.6 Effective width of intersecting walls.** Where a shear wall is anchored to an intersecting wall or walls, the width of the overhanging flange formed by the intersected wall on either side of

the shear wall, which may be assumed working with the shear wall for purposes of flexural stiffness calculations, shall not exceed six times the thickness of the intersected wall. Limits of the effective flange may be waived if justified. Only the effective area of the wall parallel to the shear forces may be assumed to carry horizontal shear.

**2106.2.7 Distribution of concentrated vertical loads in walls.** The length of wall laid up in running bond which may be considered capable of working at the maximum allowable compressive stress to resist vertical concentrated loads shall not exceed the center-to-center distance between such loads, nor the width of bearing area plus four times the wall thickness. Concentrated vertical loads shall not be assumed to be distributed across continuous vertical mortar or control joints unless elements designed to distribute the concentrated vertical loads are employed.

**2106.2.8 Loads on nonbearing walls.** Masonry walls used as interior partitions or as exterior surfaces of a building which do not carry vertical loads imposed by other elements of the building shall be designed to carry their own weight plus any superimposed finish and lateral forces. Bonding or anchorage of nonbearing walls shall be adequate to support the walls and to transfer lateral forces to the supporting elements.

**2106.2.9 Vertical deflection.** Elements supporting masonry shall be designed so that their vertical deflection will not exceed  $1/600$  of the clear span under total loads. Lintels shall bear on supporting masonry on each end such that allowable stresses in the supporting masonry are not exceeded. A minimum bearing length of 4 inches (102 mm) shall be provided for lintels bearing on masonry.

**2106.2.10 Structural continuity.** Intersecting structural elements intended to act as a unit shall be anchored together to resist the design forces.

**2106.2.11 Walls intersecting with floors and roofs.** Walls shall be anchored to all floors, roofs or other elements which provide lateral support for the wall. Where floors or roofs are designed to transmit horizontal forces to walls, the anchorage to such walls shall be designed to resist the horizontal force.

**2106.2.12 Modulus of elasticity of materials.**

**2106.2.12.1 Modulus of elasticity of masonry.** The moduli for masonry may be estimated as provided below. Actual values, where required, shall be established by test. The modulus of elasticity of masonry shall be determined by the secant method in which the slope of the line for the modulus of elasticity is taken from  $0.05 f'_m$  to a point on the curve at  $0.33 f'_m$ . These values are not to be reduced by one half as set forth in Section 2107.1.2.

Modulus of elasticity of clay or shale unit masonry.

$$E_m = 750 f'_m, 3,000,000 \text{ psi (20.5 GPa) maximum} \quad (6-3)$$

Modulus of elasticity of concrete unit masonry.

$$E_m = 750 f'_m, 3,000,000 \text{ psi (20.5 GPa) maximum} \quad (6-4)$$

**2106.2.12.2 Modulus of elasticity of steel.**

$$E_s = 29,000,000 \text{ psi (200 GPa)} \quad (6-5)$$

**2106.2.13 Shear modulus of masonry.**

$$G = 0.4 E_m \quad (6-6)$$

**2106.2.14 Placement of embedded anchor bolts.**

**2106.2.14.1 General.** Placement requirements for plate anchor bolts, headed anchor bolts and bent bar anchor bolts shall be determined in accordance with this subsection. The bent bar anchor bolt shall have a hook with a 90-degree bend with an inside diameter of three bolt diameters, plus an

extension of  $1\frac{1}{2}$  bolt diameters at the free end. Headed anchor bolts shall have a standard bolt head. Plate anchor bolts shall have a plate welded to the shank to provide anchorage equivalent to headed anchor bolts.

The effective embedment depth  $l_b$  for plate or headed anchor bolts shall be the length of embedment measured perpendicular from the surface of the masonry to the bearing surface of the plate or head of the anchorage, and  $l_b$  for bent bar anchors shall be the length of embedment measured perpendicular from the surface of the masonry to the bearing surface of the bent end minus one anchor bolt diameter. All bolts shall be grouted in place with at least 1 inch (25 mm) of grout between the bolt and the masonry, except that  $\frac{1}{4}$ -inch-diameter (6.4 mm) bolts may be placed in bed joints which are at least  $\frac{1}{2}$  inch (13 mm) in thickness.

**2106.2.14.2 Minimum edge distance.** The minimum anchor bolt edge distance  $l_{be}$  measured from the edge of the masonry parallel with the anchor bolt to the surface of the anchor bolt shall be  $1\frac{1}{2}$  inches (38 mm).

**2106.2.14.3 Minimum embedment depth.** The minimum embedment depth of anchor bolts  $l_b$  shall be four bolt diameters but not less than 2 inches (51 mm).

**2106.2.14.4 Minimum spacing between bolts.** The minimum center-to-center distance between anchor bolts shall be four bolt diameters.

**2106.2.15 Flexural resistance of cavity walls.** For computing the flexural resistance of cavity walls, lateral loads perpendicular to the plane of the wall shall be distributed to the wythes according to their respective flexural rigidities.

### 2106.3 Working Stress Design and Strength Design Requirements for Reinforced Masonry.

**2106.3.1 General.** In addition to the requirements of Sections 2106.1 and 2106.2, the design of reinforced masonry structures by the working stress design method or the strength design method shall comply with the requirements of this section.

**2106.3.2 Plain bars.** The use of plain bars larger than  $\frac{1}{4}$  inch (6.4 mm) in diameter is not permitted.

**2106.3.3 Spacing of longitudinal reinforcement.** The clear distance between parallel bars, except in columns, shall not be less than the nominal diameter of the bars or 1 inch (25 mm), except that bars in a splice may be in contact. This clear distance requirement applies to the clear distance between a contact splice and adjacent splices or bars.

The clear distance between the surface of a bar and any surface of a masonry unit shall not be less than  $\frac{1}{4}$  inch (6 mm) for fine grout and  $\frac{1}{2}$  inch (13 mm) for coarse grout. Cross webs of hollow units may be used as support for horizontal reinforcement.

**2106.3.4 Anchorage of flexural reinforcement.** The tension or compression in any bar at any section shall be developed on each side of that section by the required development length. The development length of the bar may be achieved by a combination of an embedment length, anchorage or, for tension only, hooks.

Except at supports or at the free end of cantilevers, every reinforcing bar shall be extended beyond the point at which it is no longer needed to resist tensile stress for a distance equal to 12 bar diameters or the depth of the beam, whichever is greater. No flexural bar shall be terminated in a tensile zone unless at least one of the following conditions is satisfied:

1. The shear is not over one half that permitted, including allowance for shear reinforcement where provided.
2. Additional shear reinforcement in excess of that required is provided each way from the cutoff a distance equal to the depth of the beam. The shear reinforcement spacing shall not exceed  $d/8r_b$ .
3. The continuing bars provide double the area required for flexure at that point or double the perimeter required for reinforcing bond.

At least one third of the total reinforcement provided for negative moment at the support shall be extended beyond the extreme position of the point of inflection a distance sufficient to develop one half the allowable stress in the bar, not less than  $l/16$  of the clear span, or the depth  $d$  of the member, whichever is greater.

Tensile reinforcement for negative moment in any span of a continuous restrained or cantilever beam, or in any member of a rigid frame, shall be adequately anchored by reinforcement bond, hooks or mechanical anchors in or through the supporting member.

At least one third of the required positive moment reinforcement in simple beams or at the freely supported end of continuous beams shall extend along the same face of the beam into the support at least 6 inches (153 mm). At least one fourth of the required positive moment reinforcement at the continuous end of continuous beams shall extend along the same face of the beam into the support at least 6 inches (153 mm).

Compression reinforcement in flexural members shall be anchored by ties or stirrups not less than  $1/4$  inch (6.4 mm) in diameter, spaced not farther apart than 16 bar diameters or 48 tie diameters, whichever is less. Such ties or stirrups shall be used throughout the distance where compression reinforcement is required.

**2106.3.5 Anchorage of shear reinforcement.** Single, separate bars used as shear reinforcement shall be anchored at each end by one of the following methods:

1. Hooking tightly around the longitudinal reinforcement through 180 degrees.
2. Embedment above or below the mid-depth of the beam on the compression side a distance sufficient to develop the stress in the bar for plain or deformed bars.
3. By a standard hook, as defined in Section 2107.2.2.5, considered as developing 7,500 psi (52 MPa), plus embedment sufficient to develop the remainder of the stress to which the bar is subjected. The effective embedded length shall not be assumed to exceed the distance between the mid-depth of the beam and the tangent of the hook.

The ends of bars forming a single U or multiple U stirrup shall be anchored by one of the methods set forth in Items 1 through 3 above or shall be bent through an angle of at least 90 degrees tightly around a longitudinal reinforcing bar not less in diameter than the stirrup bar, and shall project beyond the bend at least 12 stirrup diameters.

The loops or closed ends of simple U or multiple U stirrups shall be anchored by bending around the longitudinal reinforcement through an angle of at least 90 degrees and project beyond the end of the bend at least 12 stirrup diameters.

**2106.3.6 Lateral ties.** All longitudinal bars for columns shall be enclosed by lateral ties. Lateral support shall be provided to the longitudinal bars by the corner of a complete tie having an included angle of not more than 135 degrees or by a standard hook at the end of a tie. The corner bars shall have such support provided by a complete tie enclosing the longitudinal bars. Alternate longitudinal bars shall have such lateral support provided by ties and no bar shall be farther than 6 inches (153 mm) from such laterally supported bar.

Lateral ties and longitudinal bars shall be placed not less than  $1\frac{1}{2}$  inches (38 mm) and not more than 5 inches (127 mm) from the surface of the column. Lateral ties may be placed against the longitudinal bars or placed in the horizontal bed joints where the requirements of Section 2106.1.8 are met. Spacing of ties shall not exceed 16 longitudinal bar diameters, 48 tie diameters or the least dimension of the column but not more than 18 inches (457 mm).

Ties shall be at least  $1/4$  inch (6.4 mm) in diameter for No. 7 or smaller longitudinal bars and at least No. 3 for longitudinal bars larger than No. 7. Ties smaller than No. 3 may be used for longitudinal bars larger than No. 7, provided the total cross-sectional area of such smaller ties crossing a longitudinal plane is equal to that of the larger ties at their required spacing.

**2106.3.7 Column anchor bolt ties.** Additional ties shall be provided around anchor bolts which are set in the top of columns. Such ties shall engage at least four bolts or, alternately, at least four

vertical column bars or a combination of bolts and bars totaling at least four. Such ties shall be located within the top 5 inches (127 mm) of the column and shall provide a total of 0.4 square inch (260 mm<sup>2</sup>) or more in cross-sectional area. The uppermost tie shall be within 2 inches (51 mm) of the top of the column.

**2106.3.8 Effective width  $b$  of compression area.** In computing flexural stresses in walls where reinforcement occurs, the effective width assumed for running bond masonry shall not exceed six times the nominal wall thickness or the center-to-center distance between reinforcement. Where stack bond is used, the effective width shall not exceed three times the nominal wall thickness or the center-to-center distance between reinforcement or the length of one unit, unless solid grouted open-end units are used.

## SECTION 2107 — WORKING STRESS DESIGN OF MASONRY

### 2107.1 General.

**2107.1.1 Scope.** The design of masonry structures using working stress design shall comply with the provisions of Section 2106 and this section. Stresses in clay or concrete masonry under service loads shall not exceed the values given in this section.

**2107.1.2 Allowable masonry stresses.** When quality assurance provisions do not include requirements for special inspection as prescribed in Section 1701, the allowable stresses for masonry in Section 2107 shall be reduced by one half.

When one half allowable masonry stresses are used in Seismic Zones 3 and 4, the value of  $f'_m$  from Table 21-D shall be limited to a maximum of 1,500 psi (10 MPa) for concrete masonry and 2,600 psi (18 MPa) for clay masonry unless the value of  $f'_m$  is verified by tests in accordance with Section 2105.3.4, Items 1 and 4 or 6. A letter of certification is not required.

When one half allowable masonry stresses are used for design in Seismic Zones 3 and 4, the value of  $f'_m$  shall be limited to 1,500 psi (10 MPa) for concrete masonry and 2,600 psi (18 MPa) for clay masonry for Section 2105.3.2, Item 3, and Section 2105.3.3, Item 5, unless the value of  $f'_m$  is verified during construction by the testing requirements of Section 2105.3.2, Item 2. A letter of certification is not required.

### 2107.1.3 Minimum dimensions for masonry structures built in Seismic Zones 3 and 4.

**2107.1.3.1 Bearing walls.** The nominal thickness of reinforced masonry bearing walls shall not be less than 6 inches (153 mm) except that nominal 4-inch-thick (102 mm) load-bearing reinforced hollow-clay unit masonry walls may be used, provided net area unit strength exceeds 8,000 psi (55 MPa), units are laid in running bond, bar sizes do not exceed  $\frac{1}{2}$  inch (12.7 mm) with no more than two bars or one splice in a cell, and joints are flush cut, concave or a protruding V section.

**2107.1.3.2 Columns.** The least nominal dimension of a reinforced masonry column shall be 12 inches (305 mm) except that, for working stress design, if the allowable stresses are reduced by one half, the minimum nominal dimension shall be 8 inches (203 mm).

**2107.1.4 Design assumptions.** The working stress design procedure is based on working stresses and linear stress-strain distribution assumptions with all stresses in the elastic range as follows:

1. Plane sections before bending remain plane after bending.
2. Stress is proportional to strain.
3. Masonry elements combine to form a homogenous member.

### 2107.1.5 Embedded anchor bolts.

**2107.1.5.1 General.** Allowable loads for plate anchor bolts, headed anchor bolts and bent bar anchor bolts shall be determined in accordance with this section.

**2107.1.5.2 Tension.** Allowable loads in tension shall be the lesser value selected from Tables 21-E-1 and 21-E-2 or shall be determined from the lesser of Formula (7-1) or Formula (7-2).

$$B_t = 0.5 A_p \sqrt{f'_m} \quad (7-1)$$

For SI:

$$B_t = 0.042 A_p \sqrt{f'_m}$$

$$B_t = 0.2 A_b f_y \quad (7-2)$$

The area  $A_p$  shall be the lesser of Formula (7-3) or Formula (7-4) and where the projected areas of adjacent anchor bolts overlap,  $A_p$  of each anchor bolt shall be reduced by one half of the overlapping area.

$$A_p = \pi l_b^2 \quad (7-3)$$

$$A_p = \pi l_{be}^2 \quad (7-4)$$

**2107.1.5.3 Shear.** Allowable loads in shear shall be the value selected from Table 21-F or shall be determined from the lesser of Formula (7-5) or Formula (7-6).

$$B_v = 350 \sqrt[4]{f'_m A_b} \quad (7-5)$$

For SI:

$$B_v = 1070 \sqrt[4]{f'_m A_b}$$

$$B_v = 0.12 A_b f_y \quad (7-6)$$

Where the anchor bolt edge distance  $l_{be}$  in the direction of load is less than 12 bolt diameters, the value of  $B_v$  in Formula (7-5) shall be reduced by linear interpolation to zero at an  $l_{be}$  distance of 1½ inches (38 mm). Where adjacent anchors are spaced closer than  $8d_b$ , the allowable shear of the adjacent anchors determined by Formula (7-5) shall be reduced by linear interpolation to 0.75 times the allowable shear value at a center-to-center spacing of four bolt diameters.

**2107.1.5.4 Combined shear and tension.** Anchor bolts subjected to combined shear and tension shall be designed in accordance with Formula (7-7).

$$\frac{b_t}{B_t} + \frac{b_v}{B_v} \leq 1.0 \quad (7-7)$$

**2107.1.6 Compression in walls and columns.**

**2107.1.6.1 Walls, axial loads.** Stresses due to compressive forces applied at the centroid of wall may be computed by Formula (7-8) assuming uniform distribution over the effective area.

$$f_a = P/A_e \quad (7-8)$$

**2107.1.6.2 Columns, axial loads.** Stresses due to compressive forces applied at the centroid of columns may be computed by Formula (7-8) assuming uniform distribution over the effective area.

**2107.1.6.3 Columns, bending or combined bending and axial loads.** Stresses in columns due to combined bending and axial loads shall satisfy the requirements of Section 2107.2.7 where  $f_a/F_a$  is replaced by  $P/P_a$ . Columns subjected to bending shall meet all applicable requirements for flexural design.

**2107.1.7 Shear walls, design loads.** When calculating shear or diagonal tension stresses, shear walls which resist seismic forces in Seismic Zones 3 and 4 shall be designed to resist 1.5 times the forces required by Section 1628.

**2107.1.8 Design, composite construction.**

**2107.1.8.1 General.** The requirements of this section govern masonry in which at least one wythe has strength or composition characteristics different from the other wythe or wythes and is adequately bonded to act as a single structural element.

The following assumptions shall apply to the design of composite masonry:

1. Analysis shall be based on elastic transformed section of the net area.
2. The maximum computed stress in any portion of composite masonry shall not exceed the allowable stress for the material of that portion.

**2107.1.8.2 Determination of moduli of elasticity.** The modulus of elasticity of each type of masonry in composite construction shall be measured by tests if the modular ratio of the respective types of masonry exceeds 2 to 1 as determined by Section 2106.2.12.

**2107.1.8.3 Structural continuity.**

**2107.1.8.3.1 Bonding of wythes.** All wythes of composite masonry elements shall be tied together as specified in Section 2106.1.5.2 as a minimum requirement. Additional ties or the combination of grout and metal ties shall be provided to transfer the calculated stress.

**2107.1.8.3.2 Material properties.** The effect of dimensional changes of the various materials and different boundary conditions of various wythes shall be included in the design.

**2107.1.8.4 Design procedure, transformed sections.** One material is chosen as the reference material, and the other materials are transformed to an equivalent area of the reference material by multiplying the area of the other materials by the respective ratios of the modulus of elasticity of the other materials to that of the reference material. Thickness of the transformed area and its distance perpendicular to a given bending axis remain unchanged. Effective height or length of the element remains unchanged.

**2107.1.9 Reuse of masonry units.** The allowable working stresses for reused masonry units shall not exceed 50 percent of those permitted for new masonry units of the same properties.

**2107.2 Design of Reinforced Masonry.**

**2107.2.1 Scope.** The requirements of this section are in addition to the requirements of Sections 2106 and 2107.1, and govern masonry in which reinforcement is used to resist forces.

Walls with openings used to resist lateral loads whose pier and beam elements are within the dimensional limits of Section 2108.2.6.1.2 may be designed in accordance with Section 2108.2.6. Walls used to resist lateral loads not meeting the dimensional limits of Section 2108.2.6.1.2 may be designed as walls in accordance with this section or Section 2108.2.5.

**2107.2.2 Reinforcement.**

**2107.2.2.1 Maximum reinforcement size.** The maximum size of reinforcement shall be No. 11 bars. Maximum reinforcement area in cells shall be 6 percent of the cell area without splices and 12 percent of the cell area with splices.

**2107.2.2.2 Cover.** All reinforcing bars, except joint reinforcement, shall be completely embedded in mortar or grout and have a minimum cover, including the masonry unit, of at least  $\frac{3}{4}$  inch (19 mm),  $1\frac{1}{2}$  inches (38 mm) of cover when the masonry is exposed to weather and 2 inches (51 mm) of cover when the masonry is exposed to soil.

**2107.2.2.3 Development length.** The required development length  $l_d$  for deformed bars or deformed wire shall be calculated by:

$$l_d = 0.002 d_b f_s \text{ for bars in tension} \quad (7-9)$$

For SI:  $l_d = 0.29 d_b f_s \text{ for bars in tension}$

$$l_d = 0.0015 d_b f_s \text{ for bars in compression} \quad (7-10)$$

For SI:  $l_d = 0.22 d_b f_s$  for bars in compression

Development length for smooth bars shall be twice the length determined by Formula (7-9).

**2107.2.2.4 Reinforcement bond stress.** Bond stress  $u$  in reinforcing bars shall not exceed the following:

Plain Bars	60 psi (413 kPa)
Deformed Bars	200 psi (1378 kPa)
Deformed Bars without Special Inspection	100 psi (689 kPa)

**2107.2.2.5 Hooks.**

1. The term “standard hook” shall mean one of the following:
  - 1.1 A 180-degree turn plus extension of at least four bar diameters, but not less than 2½ inches (63 mm) at free end of bar.
  - 1.2 A 90-degree turn plus extension of at least 12 bar diameters at free end of bar.
  - 1.3 For stirrup and tie anchorage only, either a 90-degree or a 135-degree turn, plus an extension of at least six bar diameters, but not less than 2½ inches (63 mm) at the free end of the bar.
2. Inside diameter of bend of the bars, other than for stirrups and ties, shall not be less than that set forth in Table 21-G.
3. Inside diameter of bend for No. 5 or smaller stirrups and ties shall not be less than four bar diameters. Inside diameter of bend for bars larger than No. 5 stirrups and ties shall not be less than that given in Table 21-G.
4. Hooks shall not be permitted in the tension portion of any beam, except at the ends of simple or cantilever beams or at the freely supported end of continuous or restrained beams.
5. Hooks shall not be assumed to carry a load which would produce a tensile stress in the bar greater than 7,500 psi (52 MPa).
6. Hooks shall not be considered effective in adding to the compressive resistance of bars.
7. Any mechanical device capable of developing the strength of the bar without damage to the masonry may be used in lieu of a hook. Data must be presented to show the adequacy of such devices.

**2107.2.2.6 Splices** The amount of lap of lapped splices shall be sufficient to transfer the allowable stress of the reinforcement as specified in Sections 2106.3.4, 2107.2.2.3 and 2107.2.12. In no case shall the length of the lapped splice be less than 30 bar diameters for compression and 40 bar diameters for tension.

Welded or mechanical connections shall develop 125 percent of the specified yield strength of the bar in tension.

**EXCEPTION:** For compression bars in columns that are not part of the seismic-resisting system and are not subject to flexure, only the compressive strength need be developed.

When adjacent splices in grouted masonry are separated by 3 inches (76 mm) or less, the required lap length shall be increased 30 percent.

**EXCEPTION:** Where lap splices are staggered at least 24 bar diameters, no increase in lap length is required.

See Section 2107.2.12 for lap splice increases.

**2107.2.3 Design assumptions.** The following assumptions are in addition to those stated in Section 2107.1.4:

1. Masonry carries no tensile stress.

2. Reinforcement is completely surrounded by and bonded to masonry material so that they work together as a homogenous material within the range of allowable working stresses.

**2107.2.4 Nonrectangular flexural elements.** Flexural elements of nonrectangular cross section shall be designed in accordance with the assumptions given in Sections 2107.1.4 and 2107.2.3.

**2107.2.5 Allowable axial compressive stress and force.** For members other than reinforced masonry columns, the allowable axial compressive stress  $F_a$  shall be determined as follows:

$$F_a = 0.25f'_m \left[ 1 - \left( \frac{h'}{140r} \right)^2 \right] \text{ for } h'/r \leq 99 \quad (7-11)$$

$$F_a = 0.25f'_m \left( \frac{70r}{h'} \right)^2 \text{ for } h'/r > 99 \quad (7-12)$$

For reinforced masonry columns, the allowable axial compressive force  $P_a$  shall be determined as follows:

$$P_a = [0.25f'_m A_e + 0.65A_s F_{sc}] \left[ 1 - \left( \frac{h'}{140r} \right)^2 \right] \text{ for } h'/r \leq 99 \quad (7-13)$$

$$P_a = [0.25f'_m A_e + 0.65A_s F_{sc}] \left( \frac{70r}{h'} \right)^2 \text{ for } h'/r > 99 \quad (7-14)$$

**2107.2.6 Allowable flexural compressive stress.** The allowable flexural compressive stress  $F_b$  is:

$$F_b = 0.33 f'_m, 2,000 \text{ psi (13.8 MPa) maximum} \quad (7-15)$$

**2107.2.7 Combined compressive stresses, unity formula.** Elements subjected to combined axial and flexural stresses shall be designed in accordance with accepted principles of mechanics or in accordance with Formula (7-16):

$$\frac{f_a}{F_a} + \frac{f_b}{F_b} \leq 1 \quad (7-16)$$

**2107.2.8 Allowable shear stress in flexural members.** Where no shear reinforcement is provided, the allowable shear stress  $F_v$  in flexural members is:

$$F_v = 1.0 \sqrt{f'_m}, 50 \text{ psi maximum} \quad (7-17)$$

For SI:  $F_v = 0.083 \sqrt{f'_m}, 345 \text{ kPa maximum}$

**EXCEPTION:** For a distance of  $1/16$  the clear span beyond the point of inflection, the maximum stress shall be 20 psi (140 kPa).

Where shear reinforcement designed to take entire shear force is provided, the allowable shear stress  $F_v$  in flexural members is:

$$F_v = 3.0 \sqrt{f'_m}, 150 \text{ psi maximum} \quad (7-18)$$

For SI:  $F_v = 0.25 \sqrt{f'_m}, 1.0 \text{ MPa maximum}$

**2107.2.9 Allowable shear stress in shear walls.** Where in-plane flexural reinforcement is provided and masonry is used to resist all shear, the allowable shear stress  $F_v$  in shear walls is:

$$\text{For } M/Vd < 1, F_v = 1/3 \left( 4 - \frac{M}{Vd} \right) \sqrt{f'_m}, \left( 80 - 45 \frac{M}{Vd} \right) \text{ maximum} \quad (7-19)$$

$$\text{For SI: } F_v = 1/36 \left( 4 - \frac{M}{Vd} \right) \sqrt{f'_m}, \left( 551.2 - 310 \frac{M}{Vd} \right) \text{ maximum}$$

$$\text{For } M/Vd \geq 1, F_v = 1.0 \sqrt{f'_m}, 35 \text{ psi maximum} \quad (7-20)$$

$$\text{For SI: } F_v = 1/12 \sqrt{f'_m}, 240 \text{ kPa maximum}$$

Where shear reinforcement designed to take all the shear is provided, the allowable shear stress  $F_v$  in shear walls is:

$$\text{For } M/Vd < 1, F_v = 1/2 \left( 4 - \frac{M}{Vd} \right) \sqrt{f'_m}, \left( 120 - 45 \frac{M}{Vd} \right) \text{ maximum} \quad (7-21)$$

$$\text{For SI: For } M/Vd < 1, F_v = 1/24 \left( 4 - \frac{M}{Vd} \right) \sqrt{f'_m}, \left( 826.8 - 310 \frac{M}{Vd} \right) \text{ maximum}$$

$$\text{For } M/Vd \geq 1, F_v = 1.5 \sqrt{f'_m}, 75 \text{ psi maximum} \quad (7-22)$$

$$\text{For SI: For } M/Vd \geq 1, F_v = 0.12 \sqrt{f'_m}, 520 \text{ kPa maximum}$$

**2107.2.10 Allowable bearing stress.** When a member bears on the full area of a masonry element, the allowable bearing stress  $F_{br}$  is:

$$F_{br} = 0.26 f'_m \quad (7-23)$$

When a member bears on one third or less of a masonry element, the allowable bearing stress  $F_{br}$  is:

$$F_{br} = 0.38 f'_m \quad (7-24)$$

Formula (7-24) applies only when the least dimension between the edges of the loaded and unloaded areas is a minimum of one fourth of the parallel side dimension of the loaded area. The allowable bearing stress on a reasonably concentric area greater than one third but less than the full area shall be interpolated between the values of Formulas (7-23) and (7-24).

**2107.2.11 Allowable stresses in reinforcement.** The allowable stresses in reinforcement shall be as follows:

1. **Tensile stress,  $F_s$ .**

1.1 Deformed bars,

$$F_s = 0.5 f_y, 24,000 \text{ psi (165 MPa) maximum} \quad (7-25)$$

1.2 Wire reinforcement,

$$F_s = 0.5 f_y, 30,000 \text{ psi (207 MPa) maximum} \quad (7-26)$$

1.3 Ties, anchors and smooth bars,

$$F_s = 0.4 f_y, 20,000 \text{ psi (138 MPa) maximum} \quad (7-27)$$

2. **Compressive stress  $F_{sc}$ ,  $F_s$ .**

2.1 Deformed bars in columns,

$$F_{sc} = 0.4 f_y, 24,000 \text{ psi (165 MPa) maximum} \quad (7-28)$$

2.2 Deformed bars in flexural members,

$$F_s = 0.5 f_y, 24,000 \text{ psi (165 MPa) maximum} \quad (7-29)$$

- 2.3 Deformed bars in shear walls which are confined by lateral ties throughout the distance where compression reinforcement is required and where such lateral ties are not less than  $\frac{1}{4}$  inch in diameter and spaced not farther apart than 16 bar diameters or 48 tie diameters,

$$F_{sc} = 0.4 f_y, 24,000 \text{ psi (165 MPa) maximum} \quad (7-30)$$

**2107.2.12 Lap splice increases.** In regions of moment where the design tensile stresses in the reinforcement are greater than 80 percent of the allowable steel tensile stress  $F_s$ , the lap length of splices shall be increased not less than 50 percent of the minimum required length. Other equivalent means of stress transfer to accomplish the same 50 percent increase may be used.

**2107.2.13 Reinforcement for columns.** Columns shall be provided with reinforcement as specified in this subsection.

**2107.2.13.1 Vertical reinforcement.** The area of vertical reinforcement shall not be less than  $0.005 A_e$  and not more than  $0.04 A_e$ . At least four No. 3 bars shall be provided. The minimum clear distance between parallel bars in columns shall be two and one half times the bar diameter.

**2107.2.14 Compression in walls and columns.**

**2107.2.14.1 General.** Stresses due to compressive forces in walls and columns shall be calculated in accordance with Section 2107.2.5.

**2107.2.14.2 Walls, bending or combined bending and axial loads.** Stresses in walls due to combined bending and axial loads shall satisfy the requirements of Section 2107.2.7 where  $f_a$  is given by Formula (7-8). Walls subjected to bending with or without axial loads shall meet all applicable requirements for flexural design.

The design of walls with an  $h/t$  ratio larger than 30 shall be based on forces and moments determined from an analysis of the structure. Such analysis shall consider the influence of axial loads and variable moment of inertia on member stiffness and fixed-end moments, effect of deflections on moments and forces and the effects of duration of loads.

**2107.2.15 Flexural design, rectangular flexural elements.** Rectangular flexural elements shall be designed in accordance with the following formulas or other methods based on the assumptions given in Sections 2107.1.4, 2107.2.3 and this section.

1. Compressive stress in the masonry:

$$f_b = \frac{M}{bd^2} \left( \frac{2}{jk} \right) \quad (7-31)$$

2. Tensile stress in the longitudinal reinforcement:

$$f_s = \frac{M}{A_s j d} \quad (7-32)$$

3. Design coefficients:

$$k = \sqrt{(n\rho)^2 + 2n\rho} - n\rho \quad (7-33)$$

or

$$k = \frac{1}{1 + \frac{f_s}{n f_b}} \quad (7-34)$$

$$j = 1 - \frac{k}{3} \quad (7-35)$$

**2107.2.16 Bond of flexural reinforcement.** In flexural members in which tensile reinforcement is parallel to the compressive face, the bond stress shall be computed by the formula:

$$u = \frac{V}{\sum_o j d} \quad (7-36)$$

**2107.2.17 Shear in flexural members and shear walls.** The shear stress in flexural members and shear walls shall be computed by:

$$f_v = \frac{V}{b j d} \quad (7-37)$$

For members of *T* or *I* section, *b'* shall be substituted for *b*. Where *f<sub>v</sub>* as computed by Formula (7-37) exceeds the allowable shear stress in masonry, *F<sub>v</sub>*, web reinforcement shall be provided and designed to carry the total shear force. Both vertical and horizontal shear stresses shall be considered.

The area required for shear reinforcement placed perpendicular to the longitudinal reinforcement shall be computed by:

$$A_v = \frac{sV}{F_s d} \quad (7-38)$$

Where web reinforcement is required, it shall be so spaced that every 45-degree line extending from a point at *d/2* of the beam to the longitudinal tension bars shall be crossed by at least one line of web reinforcement.

### 2107.3 Design of Unreinforced Masonry.

**2107.3.1 General.** The requirements of this section govern masonry in which reinforcement is not used to resist design forces and are in addition to the requirements of Sections 2106 and 2107.1.

**2107.3.2 Allowable axial compressive stress.** The allowable axial compressive stress *F<sub>a</sub>* is:

$$F_a = 0.25 f'_m \left[ 1 - \left( \frac{h'}{140r} \right)^2 \right] \text{ for } h'/r \leq 99 \quad (7-39)$$

$$F_a = 0.25 f'_m \left( \frac{70r}{h'} \right)^2 \text{ for } h'/r > 99 \quad (7-40)$$

**2107.3.3 Allowable flexural compressive stress.** The allowable flexural compressive stress *F<sub>b</sub>* is:

$$F_b = 0.33 f'_m, 2,000 \text{ psi (13.8 MPa) maximum} \quad (7-41)$$

**2107.3.4 Combined compressive stresses, unity formula.** Elements subjected to combined axial and flexural stresses shall be designed in accordance with accepted principles of mechanics or in accordance with the Formula (7-42):

$$\frac{f_a}{F_a} + \frac{f_b}{F_b} \leq 1 \quad (7-42)$$

**2107.3.5 Allowable tensile stress.** Resultant tensile stress due to combined bending and axial load shall not exceed the allowable flexural tensile stress, *F<sub>t</sub>*.

The allowable tensile stress for walls in flexure without tensile reinforcement using portland cement and hydrated lime, or using mortar cement Type M or S mortar, shall not exceed the values in Table 21-I.

Values in Table 21-I for tension normal to head joints are for running bond; no tension is allowed across head joints in stack bond masonry. These values shall not be used for horizontal flexural members.

**2107.3.6 Allowable shear stress in flexural members.** The allowable shear stress  $F_v$  in flexural members is:

$$F_v = 1.0 \sqrt{f'_m}, 50 \text{ psi maximum} \quad (7-43)$$

For SI:  $F_v = 0.083 \sqrt{f'_m}, 345 \text{ kPa maximum}$

**EXCEPTION:** For a distance of  $1/16$ th the clear span beyond the point of inflection, the maximum stress shall be 20 psi (138 kPa).

**2107.3.7 Allowable shear stress in shear walls.** The allowable shear stress  $F_v$  in shear walls is as follows:

1. Clay units,  $F_v = 0.3 \sqrt{f'_m}, 80 \text{ psi maximum} \quad (7-44)$

For SI:  $F_v = 0.025 \sqrt{f'_m}, 551 \text{ kPa maximum}$

2. Concrete units with Type M or S mortar,  $F_v = 34 \text{ psi (234 kPa) maximum.}$

3. Concrete units with Type N mortar,  $F_v = 23 \text{ psi (158 kPa) maximum.}$

4. The allowable shear stress in unreinforced masonry may be increased by  $0.2 f_{md}$ .

**2107.3.8 Allowable bearing stress.** When a member bears on the full area of a masonry element, the allowable bearing stress  $F_{br}$  shall be:

$$F_{br} = 0.26 f'_m \quad (7-45)$$

When a member bears on one-third or less of a masonry element, the allowable bearing stress  $F_{br}$  shall be:

$$F_{br} = 0.38 f'_m \quad (7-46)$$

Formula (7-46) applies only when the least dimension between the edges of the loaded and unloaded areas is a minimum of one fourth of the parallel side dimension of the loaded area. The allowable bearing stress on a reasonably concentric area greater than one third but less than the full area shall be interpolated between the values of Formulas (7-45) and (7-46).

**2107.3.9 Bending or combined bending and axial loads, compressive stresses.** Compressive stresses due to combined bending and axial loads shall satisfy the requirements of Section 2107.3.4.

**2107.3.10 Compression in walls and columns.** Stresses due to compressive forces in walls and columns shall be calculated in accordance with Section 2107.2.5.

**2107.3.11 Flexural design.** Stresses due to flexure shall not exceed the values given in Sections 2107.1.2, 2107.3.3 and 2107.3.5, where:

$$f_b = Mc/I \quad (7-47)$$

**2107.3.12 Shear in flexural members and shear walls.** Shear calculations for flexural members and shear walls shall be based on Formula (7-48).

$$f_v = V/A_e \quad (7-48)$$

**2107.3.13 Corbels.** The slope of corbelling (angle measured from the horizontal to the face of the corbelled surface) of unreinforced masonry shall not be less than 60 degrees.

The maximum horizontal projection of corbelling from the plane of the wall shall be such that allowable stresses are not exceeded.

**2107.3.14 Stack bond.** Masonry units laid in stack bond shall have longitudinal reinforcement of at least 0.00027 times the vertical cross-sectional area of the wall placed horizontally in the bed joints or in bond beams spaced vertically not more than 48 inches (1219 mm) apart.

## SECTION 2108 — STRENGTH DESIGN OF MASONRY

### 2108.1 General.

**2108.1.1 General provisions.** The design of reinforced hollow-unit clay and concrete masonry structures using strength design shall comply with the provisions of Section 2106 and this section.

**EXCEPTION:** Two-wythe solid-unit masonry may be used under Sections 2108.2.1 and 2108.2.4.

**2108.1.2 Quality assurance provisions.** Special inspection during construction shall be provided as set forth in Section 1701.5, Item 7.

The value of  $f'_m$  shall be verified in accordance with Section 2105.3.

**2108.1.3 Required strength.** The required strength shall be determined as follows:

1. For earthquake loading, the load factors shall be:

$$U = 1.4(D + L + E) \quad (8-1)$$

$$U = 0.9D \pm 1.4E \quad (8-2)$$

2. Required strength  $U$  to resist dead load  $D$  and live load  $L$  shall be at least equal to:

$$U = 1.4D + 1.7L \quad (8-3)$$

3. If resistance to structural effects of a specified wind load  $W$  are included in design, the following combinations of  $D$ ,  $L$  and  $W$  shall be investigated to determine the greatest required strength  $U$ .

$$U = 0.75(1.4D + 1.7L + 1.7W) \quad (8-4)$$

where load combinations shall include both full value and zero value of  $L$  to determine the more severe conditions, and

$$U = 0.9D + 1.3W \quad (8-5)$$

However, for any combination of  $D$ ,  $L$  and  $W$ , required strength  $U$  shall not be less than the value determined from Formula (8-3).

4. If resistance to earth pressure  $H$  is included in design, required strength  $U$  shall be at least equal to

$$U = 1.4D + 1.7L + 1.7H \quad (8-6)$$

except that where  $D$  or  $L$  reduces the effect of  $H$ ,  $0.9D$  shall be substituted for  $1.4D$  and zero value of  $L$  shall be used to determine the greatest required strength  $U$ . For any combination of  $D$ ,  $L$  and  $H$ , required strength  $U$  shall not be less than the value determined from Formula (8-3).

5. If resistance to loadings due to weight and pressure of fluids with well-defined densities and controllable maximum heights  $F$  is included in design, such loadings shall have a load factor of 1.4 and be added to all loading combinations that include live load.

6. If resistance to impact effects is taken into account in design, such effects shall be included with live load,  $L$ .

7. Where structural effects  $T$  of differential settlement, creep, shrinkage or temperature change may be significant in design, required strength  $U$  shall be at least equal to:

$$U = 0.75(1.4D + 1.4T + 1.7L) \quad (8-7)$$

but required strength  $U$  shall not be less than:

$$U = 1.4 (D + T) \quad (8-8)$$

**2108.1.4 Design strength.** Design strength is the nominal strength, multiplied by the strength-reduction factor,  $\phi$ , as specified in this section. Masonry members shall be proportioned such that the design strength exceeds the required strength.

**2108.1.4.1 Beams, piers and columns.**

**2108.1.4.1.1 Flexure.** Flexure with or without axial load, the value of  $\phi$  shall be determined from Formula (8-9):

$$\phi = 0.8 - \frac{P_u}{A_e f'_m} \quad (8-9)$$

$$\text{and } 0.60 \leq \phi \leq 0.80$$

**2108.1.4.1.2 Shear.** Shear:  $\phi = 0.60$

**2108.1.4.2 Wall design for out-of-plane loads.**

**2108.1.4.2.1 Walls with factored axial load of  $0.04 f'_m$  or less.**

Flexure:  $\phi = 0.80$ .

**2108.1.4.2.2 Walls with factored axial load greater than  $0.04 f'_m$ .**

Axial load and axial load with flexure:  $\phi = 0.80$ .

Shear:  $\phi = 0.60$ .

**2108.1.4.3 Wall design for in-plane loads.**

**2108.1.4.3.1 Axial load.** Axial load and axial load with flexure:  $\phi = 0.65$ .

For walls with symmetrical reinforcement in which  $f_y$  does not exceed 60,000 psi (413 MPa), the value of  $\phi$  may be increased linearly to 0.85 as the value of  $\phi P_n$  decreases from  $0.10 f'_m A_e$  or  $0.25 P_b$  to zero.

For solid grouted walls, the value of  $P_b$  may be calculated by Formula (8-10)

$$P_b = 0.85 f'_m b a_b \quad (8-10)$$

**WHERE:**

$$a_b = 0.85d \{ e_{mu} / [e_{mu} + (f_y / E_s)] \} \quad (8-11)$$

**2108.1.4.3.2 Shear.** Shear:  $\phi = 0.60$

The value of  $\phi$  may be 0.80 for any shear wall when its nominal shear strength exceeds the shear corresponding to development of its nominal flexural strength for the factored-load combination.

**2108.1.4.4 Moment-resisting wall frames.**

**2108.1.4.4.1 Flexure with or without axial load.** The value of  $\phi$  shall be as determined from Formula (8-12); however, the value of  $\phi$  shall not be less than 0.65 nor greater than 0.85.

$$\phi = 0.85 - 2 \left( \frac{P_u}{A_n f'_m} \right) \quad (8-12)$$

**2108.1.4.4.2 Shear.** Shear:  $\phi = 0.80$

**2108.1.4.5 Anchor.** Anchor bolts:  $\phi = 0.80$

**2108.1.4.6 Reinforcement.****2108.1.4.6.1 Development.** Development:  $\phi = 0.80$ **2108.1.4.6.2 Splices.** Splices:  $\phi = 0.80$ **2108.1.5 Anchor bolts.****2108.1.5.1 Required strength.** The required strength of embedded anchor bolts shall be determined from factored loads as specified in Section 2108.1.3.**2108.1.5.2 Nominal anchor bolt strength.** The nominal strength of anchor bolts times the strength-reduction factor shall equal or exceed the required strength.

The nominal tensile capacity of anchor bolts shall be determined from the lesser of Formula (8-13) or (8-14).

$$B_m = 1.0A_p \sqrt{f'_m} \quad (8-13)$$

For SI:

$$B_m = 0.084A_p \sqrt{f'_m}$$

$$B_m = 0.4A_b f_y \quad (8-14)$$

The area  $A_p$  shall be the lesser of Formula (8-15) or (8-16) and where the projected areas of adjacent anchor bolts overlap, the value of  $A_p$  of each anchor bolt shall be reduced by one half of the overlapping area.

$$A_p = \pi l_b^2 \quad (8-15)$$

$$A_p = \pi l_{be}^2 \quad (8-16)$$

The nominal shear capacity of anchor bolts shall be determined from the lesser of Formula (8-17) or (8-18).

$$B_{sn} = 900 \sqrt[4]{f'_m A_b} \quad (8-17)$$

For SI:

$$B_{sn} = 2750 \sqrt[4]{f'_m A_b}$$

$$B_{sn} = 0.25A_s f_y \quad (8-18)$$

Where the anchor bolt edge distance,  $l_{be}$ , in the direction of load is less than 12 bolt diameters, the value of  $B_m$  in Formula (8-17) shall be reduced by linear interpolation to zero at an  $l_{be}$  distance of 1½ inches (38 mm). Where adjacent anchor bolts are spaced closer than  $8d_b$ , the nominal shear strength of the adjacent anchors determined by Formula (8-17) shall be reduced by linear interpolation to 0.75 times the nominal shear strength at a center-to-center spacing of four bolt diameters.

Anchor bolts subjected to combined shear and tension shall be designed in accordance with Formula (8-19).

$$\frac{b_{tu}}{\phi B_m} + \frac{b_{su}}{\phi B_{sn}} \leq 1.0 \quad (8-19)$$

**2108.1.5.3 Anchor bolt placement.** Anchor bolts shall be placed so as to meet the edge distance, embedment depth and spacing requirements of Sections 2106.2.14.2, 2106.2.14.3 and 2106.2.14.4.**2108.2 Reinforced Masonry.****2108.2.1 General.****2108.2.1.1 Scope.** The requirements of this section are in addition to the requirements of Sections 2106 and 2108.1 and govern masonry in which reinforcement is used to resist forces.

**2108.2.1.2 Design assumptions.** The following assumptions apply:

Masonry carries no tensile stress greater than the modulus of rupture.

Reinforcement is completely surrounded by and bonded to masonry material so that they work together as a homogeneous material.

Nominal strength of singly reinforced masonry wall cross sections to combined flexure and axial load shall be based on applicable conditions of equilibrium and compatibility of strains. Strain in reinforcement and masonry walls shall be assumed to be directly proportional to the distance from the neutral axis.

Maximum usable strain,  $e_{mu}$ , at the extreme masonry compression fiber shall:

1. Be 0.003 for the design of beams, piers, columns and walls.
2. Not exceed 0.003 for moment-resisting wall frames, unless lateral reinforcement as defined in Section 2108.2.6.2.6 is utilized.

Strain in reinforcement and masonry shall be assumed to be directly proportional to the distance from the neutral axis.

Stress in reinforcement below specified yield strength  $f_y$  for grade of reinforcement used shall be taken as  $E_s$  times steel strain. For strains greater than that corresponding to  $f_y$ , stress in reinforcement shall be considered independent of strain and equal to  $f_y$ .

Tensile strength of masonry walls shall be neglected in flexural calculations of strength, except when computing requirements for deflection.

Relationship between masonry compressive stress and masonry strain may be assumed to be rectangular as defined by the following:

Masonry stress of  $0.85 f'_m$  shall be assumed uniformly distributed over an equivalent compression zone bounded by edges of the cross section and a straight line located parallel to the neutral axis at a distance  $a = 0.85c$  from the fiber of maximum compressive strain. Distance  $c$  from fiber of maximum strain to the neutral axis shall be measured in a direction perpendicular to that axis.

## **2108.2.2 Reinforcement requirements and details.**

**2108.2.2.1 Maximum reinforcement.** The maximum size of reinforcement shall be No. 9. The diameter of a bar shall not exceed one fourth the least dimension of a cell. No more than two bars shall be placed in a cell of a wall or a wall frame.

**2108.2.2.2 Placement.** The placement of reinforcement shall comply with the following:

In columns and piers, the clear distance between vertical reinforcing bars shall not be less than one and one-half times the nominal bar diameter, nor less than  $1\frac{1}{2}$  inches (38 mm).

**2108.2.2.3 Cover.** All reinforcing bars shall be completely embedded in mortar or grout and shall have a cover of not less than  $1\frac{1}{2}$  inches (38 mm) nor less than  $2.5 d_b$ .

**2108.2.2.4 Standard hooks.** A standard hook shall be one of the following:

1. A 180-degree turn plus an extension of at least four bar diameters, but not less than  $2\frac{1}{2}$  inches (63 mm) at the free end of the bar.
2. A 135-degree turn plus an extension of at least six bar diameters at the free end of the bar.
3. A 90-degree turn plus an extension of at least 12 bar diameters.

**2108.2.2.5 Minimum bend diameter for reinforcing bars.** Diameter of bend measured on the inside of a bar other than for stirrups and ties in sizes No. 3 through No. 5 shall not be less than the values in Table 21-G.

Inside diameter of bends for stirrups and ties shall not be less than  $4d_b$  for No. 5 bars and smaller. For bars larger than No. 5, diameter of bend shall be in accordance with Table 21-G.

**2108.2.2.6 Development.** The calculated tension or compression reinforcement shall be developed in accordance with the following provisions:

The embedment length of reinforcement shall be determined by Formula (8-20).

$$l_d = l_{de} / \phi \quad (8-20)$$

**WHERE:**

$$l_{de} = \frac{0.15d_b^2 f_y}{K \sqrt{f'_m}} \leq 52d_b \quad (8-21)$$

For **SI:**

$$l_{de} = \frac{1.8d_b^2 f_y}{K \sqrt{f'_m}} \leq 52d_b$$

$K$  shall not exceed  $3d_b$ .

The minimum embedment length of reinforcement shall be 12 inches (305 mm).

**2108.2.2.7 Splices.** Reinforcement splices shall comply with one of the following:

1. The minimum length of lap for bars shall be 12 inches (305 mm) or the length determined by Formula (8-22).

$$l_d = l_{de} / \phi \quad (8-22)$$

Bars spliced by noncontact lap splices shall be spaced transversely not farther apart than one fifth the required length of lap nor more than 8 inches (203 mm).

2. A welded splice shall have the bars butted and welded to develop in tens on 125 percent of the yield strength of the bar,  $f_y$ .

3. Mechanical splices shall have the bars connected to develop in tension or compression, as required, at least 125 percent of the yield strength of the bar,  $f_y$ .

**2108.2.3 Design of beams, piers and columns.**

**2108.2.3.1 General.** The requirements of this section are for the design of masonry beams, piers and columns.

The value of  $f'_m$  shall not be less than 1,500 psi (10.3 MPa). For computational purposes, the value of  $f'_m$  shall not exceed 4,000 psi (27.6 MPa).

**2108.2.3.2 Design assumptions.**

Member design forces shall be based on an analysis which considers the relative stiffness of structural members. The calculation of lateral stiffness shall include the contribution of all piers, beams and columns.

The effects of cracking on member stiffness shall be considered. Unless stiffness values are obtained by a more comprehensive analysis, the effective moment of inertia shall be determined in accordance with Formula (8-23).

$$I_e = \left( \frac{M_{cr}}{M_a} \right)^3 I_{gt} + \left[ 1 - \left( \frac{M_{cr}}{M_a} \right)^3 \right] I_{cr} \leq I_g \quad (8-23)$$

The drift ratio of piers and columns shall satisfy the limits specified in Chapter 16.

**2108.2.3.3 Balanced reinforcement ratio for compression limit state.** Calculation of the balanced reinforcement ratio,  $\rho_b$ , shall be based on the following assumptions:

1. The distribution of strain across the section shall be assumed to vary linearly from the maximum usable strain,  $e_{mu}$ , at the extreme compression fiber of the element, to a yield strain of  $f_y/E_s$  at the extreme tension fiber of the element.
2. Compression forces shall be in equilibrium with the sum of tension forces in the reinforcement and the maximum axial load associated with a loading combination  $1.0D + 1.0L + (1.4E \text{ or } 1.3W)$ .
3. The reinforcement shall be assumed to be uniformly distributed over the depth of the element and the balanced reinforcement ratio shall be calculated as the area of this reinforcement divided by the net area of the element.
4. All longitudinal reinforcement shall be included in calculating the balanced reinforcement ratio except that the contribution of compression reinforcement to resistance of compressive loads shall not be considered.

**2108.2.3.4 Required strength.** Except as required by Sections 2108.2.3.6 through 2108.2.3.12, the required strength shall be determined in accordance with Section 2108.1.3.

**2108.2.3.5 Design strength.** Design strength provided by beam, pier or column cross sections in terms of axial force, shear and moment shall be computed as the nominal strength multiplied by the applicable strength-reduction factor,  $\phi$ , specified in Section 2108.1.4.

**2108.2.3.6 Nominal strength.**

**2108.2.3.6.1 Nominal axial and flexural strength.** The nominal axial strength,  $P_n$ , and the nominal flexural strength,  $M_n$ , of a cross section shall be determined in accordance with the design assumptions of Section 2108.2.1.2 and 2108.2.3.2.

The maximum nominal axial compressive strength shall be determined in accordance with Formula (8-24).

$$P_n = 0.80[0.85f'_m(A_e - A_s) + f_y A_s] \quad (8-24)$$

**2108.2.3.6.2 Nominal shear strength.** The nominal shear strength shall be determined in accordance with Formula (8-25).

$$V_n = V_m + V_s \quad (8-25)$$

**WHERE:**

$$V_m = C_d A_e \sqrt{f'_m}, \quad 63C_d A_e \text{ maximum} \quad (8-26)$$

For SI: 
$$V_m = 0.083 C_d A_e \sqrt{f'_m}, \quad 63C_d A_e \text{ maximum}$$

and

$$V_s = A_e \rho_n f_y \quad (8-27)$$

1. The nominal shear strength shall not exceed the value given in Table 21-J.
2. The value of  $V_m$  shall be assumed to be zero within any region subjected to net tension factored loads.
3. The value of  $V_m$  shall be assumed to be 25 psi (172 kPa) where  $M_u$  is greater than  $0.7 M_n$ . The required moment,  $M_u$ , for seismic design for comparison with the  $0.7 M_n$  value of this section shall be based on an  $R_w$  of 3.

**2108.2.3.7 Reinforcement.**

1. Where transverse reinforcement is required, the maximum spacing shall not exceed one half the depth of the member nor 48 inches (1219 mm).

2. Flexural reinforcement shall be uniformly distributed throughout the depth of the element.
3. Flexural elements subjected to load reversals shall be symmetrically reinforced.
4. The nominal moment strength at any section along a member shall not be less than one fourth of the maximum moment strength.
5. The flexural reinforcement ratio,  $\rho$ , shall not exceed  $0.5 \rho_b$ .
6. Lap splices shall comply with the provisions of Section 2108.2.2.7.
7. Welded splices and mechanical splices which develop at least 125 percent of the specified yield strength of a bar may be used for splicing the reinforcement. Not more than two longitudinal bars shall be spliced at a section. The distance between splices of adjacent bars shall be at least 30 inches (762 mm) along the longitudinal axis.
8. Specified yield strength of reinforcement shall not exceed 60,000 psi (413 MPa). The actual yield strength based on mill tests shall not exceed 1.3 times the specified yield strength.

**2108.2.3.8 Seismic design provisions.** The lateral seismic load resistance in any line or story level shall be provided by shear walls or wall frames, or a combination of shear walls and wall frames. Shear walls and wall frames shall provide at least 80 percent of the lateral stiffness in any line or story level.

**EXCEPTION:** Where seismic loads are determined based on  $R_w$ , not greater than three and where all joints satisfy the provisions of Section 2108.2.6.2.9, the piers may be used to provide seismic load resistance.

**2108.2.3.9 Dimensional limits.** Dimensions shall be in accordance with the following:

1. **Beams.**
  - 1.1 The nominal width of a beam shall not be less than 6 inches (153 mm).
  - 1.2 The clear distance between locations of lateral bracing of the compression side of the beam shall not exceed 32 times the least width of the compression area.
  - 1.3 The nominal depth of a beam shall not be less than 8 inches (203 mm).
2. **Piers.**
  - 2.1 The nominal width of a pier shall not be less than 6 inches (153 mm) and shall not exceed 16 inches (406 mm).
  - 2.2 The distance between lateral supports of a pier shall not exceed 30 times the nominal width of the piers except as provided for in Section 2108.2.3.9, Item 2.3.
  - 2.3 When the distance between lateral supports of a pier exceeds 30 times the nominal width of the pier, the provisions of Section 2108.2.4 shall be used for design.
  - 2.4 The nominal length of a pier shall not be less than three times the nominal width of the pier. The nominal length of a pier shall not be greater than six times the nominal width of the pier. The clear height of a pier shall not exceed five times the nominal length of the pier.

**EXCEPTION:** The length of a pier may be equal to the width of the pier when the axial force at the location of maximum moment is less than  $0.04 f'_m A_g$ .

3. **Columns.**
  - 3.1 The nominal width of a column shall not be less than 12 inches (305 mm).
  - 3.2 The distance between lateral supports of a column shall not exceed 30 times the nominal width of the column.
  - 3.3 The nominal length of a column shall not be less than 12 inches (305 mm) and not greater than three times the nominal width of the column.

**2108.2.3.10 Beams.**

**2108.2.3.10.1 Scope.** Members designed primarily to resist flexure shall comply with the requirements of this section. The factored axial compressive force on a beam shall not exceed  $0.05 A_e f'_m$ .

**2108.2.3.10.2 Longitudinal reinforcement.**

1. The variation in the longitudinal reinforcing bars shall not be greater than one bar size. Not more than two bar sizes shall be used in a beam.

2. The nominal flexural strength of a beam shall not be less than 1.3 times the nominal cracking moment strength of the beam. The modulus of rupture,  $f_r$ , for this calculation shall be assumed to be 235 psi (1.6 MPa).

**2108.2.3.10.3 Transverse reinforcement.** Transverse reinforcement shall be provided where  $V_u$  exceeds  $V_m$ . Required shear,  $V_u$ , shall include the effects of drift. The value of  $V_u$  shall be based on  $3R_w/8$  times seismic drift. When transverse shear reinforcement is required, the following provisions shall apply:

1. Shear reinforcement shall be a single bar with a 180-degree hook at each end.
2. Shear reinforcement shall be hooked around the longitudinal reinforcement
3. The minimum transverse shear reinforcement ratio shall be 0.0007.
4. The first transverse bar shall not be more than one fourth of the beam depth from the end of the beam.

**2108.2.3.10.4 Construction.** Beams shall be solid grouted.

**2108.2.3.11 Piers.**

**2108.2.3.11.1 Scope.** Piers proportioned to resist flexure and shear in conjunction with axial load shall comply with the requirements of this section. The factored axial compression on the piers shall not exceed  $0.3 A_e f'_m$ .

**2108.2.3.11.2 Longitudinal reinforcement.** A pier subjected to in-plane stress reversals shall be longitudinally reinforced symmetrically on both sides of the neutral axis of the pier.

1. One bar shall be provided in the end cells.
2. The minimum longitudinal reinforcement ratio shall be 0.0007.

**2108.2.3.11.3 Transverse reinforcement.** Transverse reinforcement shall be provided where  $V_u$  exceeds  $V_m$ . Required shear,  $V_u$ , shall include the effects of drift. The value of  $V_u$  shall be based on  $3R_w/8$  times seismic drift. When transverse shear reinforcement is required, the following provisions shall apply:

1. Shear reinforcement shall be hooked around the extreme longitudinal bars with a 180-degree hook. Alternatively, at wall intersections, transverse reinforcement with a 90-degree standard hook around a vertical bar in the intersecting wall shall be permitted.
2. The minimum transverse reinforcement ratio shall be 0.0015.

**2108.2.3.12 Columns.**

**2108.2.3.12.1 Scope.** Columns shall comply with the requirements of this section.

**2108.2.3.12.2 Longitudinal reinforcement.** Longitudinal reinforcement shall be a minimum of four bars, one in each corner of the column.

1. Maximum reinforcement area shall be  $0.03 A_e$ .
2. Minimum reinforcement area shall be  $0.005 A_e$ .

**2108.2.3.12.3 Lateral ties.**

1. Lateral ties shall be provided in accordance with Section 2106.3.6.
2. Minimum lateral reinforcement area shall be  $0.0018 A_g$ .

**2108.2.3.12.4 Construction.** Columns shall be solid grouted.

**2108.2.4 Wall design for out-of-plane loads.**

**2108.2.4.1 General.** The requirements of this section are for the design of walls for out-of-plane loads.

**2108.2.4.2 Maximum reinforcement.** The reinforcement ratio shall not exceed  $0.5\rho_b$ .

**2108.2.4.3 Moment and deflection calculations.** All moment and deflection calculations in Section 2108.2.4 are based on simple support conditions top and bottom. Other support and fixity conditions, moments and deflections shall be calculated using established principles of mechanics.

**2108.2.4.4 Walls with axial load of  $0.04f'_m$  or less.** The procedures set forth in this section, which consider the slenderness of walls by representing effects of axial forces and deflection in calculation of moments, shall be used when the vertical load stress at the location of maximum moment does not exceed  $0.04f'_m$  as computed by Formula (8-28). The value of  $f'_m$  shall not exceed 6,000 psi (41.3 MPa).

$$\frac{P_w + P_f}{A_g} \leq 0.04 f'_m \quad (8-28)$$

Walls shall have a minimum nominal thickness of 6 inches (153 mm).

Required moment and axial force shall be determined at the midheight of the wall and shall be used for design. The factored moment,  $M_u$ , at the midheight of the wall shall be determined by Formula (8-29).

$$M_u = \frac{w_u h^2}{8} + P_{uf} \frac{e}{2} + P_u \Delta_u \quad (8-29)$$

**WHERE:**

$\Delta_u$  = deflection at midheight of wall due to factored loads

$$P_u = P_{uw} + P_{uf} \quad (8-30)$$

The design strength for out-of-plane wall loading shall be determined by Formula (8-31).

$$M_u \leq \phi M_n \quad (8-31)$$

**WHERE:**

$$M_n = A_{se} f_y (d - a/2) \quad (8-32)$$

$$A_{se} = (A_s f_y + P_u) / f_y, \text{ effective area of steel} \quad (8-33)$$

$$a = (P_u + A_s f_y) / 0.85 f'_m b, \text{ depth of stress block due to factored loads} \quad (8-34)$$

**2108.2.4.5 Wall with axial load greater than  $0.04f'_m$ .** The procedures set forth in this section shall be used for the design of masonry walls when the vertical load stresses at the location of maximum moment exceed  $0.04f'_m$  but are less than  $0.2f'_m$  and the slenderness ratio  $h/t$  does not exceed 30.

Design strength provided by the wall cross section in terms of axial force, shear and moment shall be computed as the nominal strength multiplied by the applicable strength-reduction factor,  $\phi$ , specified in Section 2108.1.4. Walls shall be proportioned such that the design strength exceeds the required strength.

The nominal shear strength shall be determined by Formula (8-35).

$$V_n = 2A_{mv} \sqrt{f'_m} \quad (8-35)$$

For SI:

$$V_n = 0.166A_{mv} \sqrt{f'_m}$$

**2108.2.4.6 Deflection design.** The midheight deflection,  $\Delta_s$ , under service lateral and vertical loads (without load factors) shall be limited by the relation:

$$\Delta_s = 0.007h \quad (8-36)$$

$P\Delta$  effects shall be included in deflection calculation. The midheight deflection shall be computed with the following formula:

$$\Delta_s = \frac{5 M_s h^2}{48 E_m I_g} \text{ for } M_{ser} \leq M_{cr} \quad (8-37)$$

$$\Delta_s = \frac{5 M_{cr} h^2}{48 E_m I_g} + \frac{5 (M_{ser} - M_{cr}) h^2}{48 E_m I_{cr}} \text{ for } M_{cr} < M_{ser} < M_s \quad (8-38)$$

The cracking moment strength of the wall shall be determined from the formula:

$$M_{cr} = S f_r \quad (8-39)$$

The modulus of rupture,  $f_r$ , shall be as follows:

1. For fully grouted hollow-unit masonry,

$$f_r = 4.0 \sqrt{f'_m}, \text{ 235 psi maximum} \quad (8-40)$$

For SI:  $f_r = 0.33 \sqrt{f'_m}, \text{ 1.6 MPa maximum}$

2. For partially grouted hollow-unit masonry,

$$f_r = 2.5 \sqrt{f'_m}, \text{ 125 psi maximum} \quad (8-41)$$

For SI:  $f_r = 0.21 \sqrt{f'_m}, \text{ 861 kPa maximum}$

3. For two-wythe brick masonry,

$$f_r = 2.0 \sqrt{f'_m}, \text{ 125 psi maximum} \quad (8-42)$$

For SI:  $f_r = 0.166 \sqrt{f'_m}, \text{ 861 kPa maximum}$

### 2108.2.5 Wall design for in-plane loads.

**2108.2.5.1 General.** The requirements of this section are for the design of walls for in-plane loads.

The value of  $f'_m$  shall not be less than 1,500 psi (10.3 MPa) nor greater than 4,000 psi (27.6 MPa).

**2108.2.5.2 Reinforcement.** Reinforcement shall be in accordance with the following:

1. Minimum reinforcement shall be provided in accordance with Section 2106.1.12.4, Item 2.3, for all seismic areas using this method of analysis.

2. When the shear wall failure mode is in flexure, the nominal flexural strength of the shear wall shall be at least 1.8 times the cracking moment strength of a fully grouted wall or 3.0 times the cracking moment strength of a partially grouted wall from Formula (8-39).

3. The amount of vertical reinforcement shall not be less than one half the horizontal reinforcement.

4. Spacing of horizontal reinforcement within the region defined in Section 2108.2.5.5, Item 3, shall not exceed three times the nominal wall thickness nor 24 inches (610 mm).

**2108.2.5.3 Design strength.** Design strength provided by the shear wall cross section in terms of axial force, shear and moment shall be computed as the nominal strength multiplied by the applicable strength-reduction factor,  $\phi$ , specified in Section 2108.1.4.3.

**2108.2.5.4 Axial strength.** The nominal axial strength of the shear wall supporting axial loads only shall be calculated by Formula (8-43).

$$P_o = 0.85 f'_m (A_e - A_s) + f_y A_s \quad (8-43)$$

Axial design strength provided by the shear wall cross section shall satisfy Formula (8-44).

$$P_u \leq 0.80 \phi P_o \quad (8-44)$$

**2108.2.5.5 Shear strength.** Shear strength shall be as follows:

1. The nominal shear strength shall be determined using either Item 2 or 3 below. Maximum nominal shear strength values are determined from Table 21-J.
2. The nominal shear strength of the shear wall shall be determined from Formula (8-45), except as provided in Item 3 below

$$V_n = V_m + V_s \quad (8-45)$$

**WHERE:**

$$V_m = C_d A_{mv} \sqrt{f'_m} \quad (8-46)$$

For SI: 
$$V_m = 0.083 C_d A_{mv} \sqrt{f'_m}$$

and

$$V_s = A_{mv} \rho_n f_y \quad (8-47)$$

3. For a shear wall whose nominal shear strength exceeds the shear corresponding to development of its nominal flexural strength, two shear regions exist.

For all cross sections within the region defined by the base of the shear wall and a plane at a distance  $L_w$  above the base of the shear wall, the nominal shear strength shall be determined from Formula (8-48).

$$V_n = A_{mv} \rho_n f_y \quad (8-48)$$

The required shear strength for this region shall be calculated at a distance  $L_w/2$  above the base of the shear wall, but not to exceed one half story height.

For the other region, the nominal shear strength of the shear wall shall be determined from Formula (8-45).

**2108.2.5.6 Boundary members.** Boundary members shall be as follows:

1. Boundary members shall be provided at the boundaries of shear walls when the compressive strains in the wall exceed 0.0015. The strain shall be determined using factored forces and  $R_w$  equal to 1.5.
2. The minimum length of the boundary member shall be three times the thickness of the wall, but shall include all areas where the compressive strain per Section 2108.2.6.2.7 is greater than 0.0015.
3. Lateral reinforcement shall be provided for the boundary elements. The lateral reinforcement shall be a minimum of No. 3 bars at a maximum of 8-inch (203 mm) spacing within the grouted core or equivalent confinement which can develop an ultimate compressive masonry strain of at least 0.006.

**2108.2.6 Design of moment-resisting wall frames.**

**2108.2.6.1 General requirements.**

**2108.2.6.1.1 Scope.** The requirements of this section are for the design of fully grouted moment-resisting wall frames constructed of reinforced open-end hollow-unit concrete or hollow-unit clay masonry.

**2108.2.6.1.2 Dimensional limits.** Dimensions shall be in accordance with the following.

**Beams.** Clear span for the beam shall not be less than two times its depth.

The nominal depth of the beam shall not be less than two units or 16 inches (406 mm), whichever is greater. The nominal beam depth to nominal beam width ratio shall not exceed 6.

The nominal width of the beam shall be the greater of 8 inches (203 mm) or  $1/26$  of the clear span between pier faces.

**Piers.** The nominal depth of piers shall not exceed 96 inches (2438 mm). Nominal depth shall not be less than two full units or 32 inches (813 mm), whichever is greater.

The nominal width of piers shall not be less than the nominal width of the beam, nor less than 8 inches (203 mm) or  $1/14$  of the clear height between beam faces, whichever is greater.

The clear height-to-depth ratio of piers shall not exceed 5.

**2108.2.6.1.3 Analysis.** Member design forces shall be based on an analysis which considers the relative stiffness of pier and beam members, including the stiffening influence of joints.

The calculation of beam moment capacity for the determination of pier design shall include any contribution of floor slab reinforcement.

The out-of-plane drift ratio of all piers shall satisfy the drift-ratio limits specified in Section 1628.8.2.

**2108.2.6.2 Design procedure.**

**2108.2.6.2.1 Required strength.** Except as required by Sections 2108.2.6.2.7 and 2108.2.6.2.8, the required strength shall be determined in accordance with Section 2108.1.3.

**2108.2.6.2.2 Design strength.** Design strength provided by frame member cross sections in terms of axial force, shear and moment shall be computed as the nominal strength multiplied by the applicable strength-reduction factor,  $\phi$ , specified in Section 2108.1.4.4.

Members shall be proportioned such that the design strength exceeds the required strength.

**2108.2.6.2.3 Design assumptions for nominal strength.** The nominal strength of member cross sections shall be based on assumptions prescribed in Section 2108.2.1.2.

The value of  $f'_m$  shall not be less than 1,500 psi (10.3 MPa) or greater than 4,000 psi (27.6 MPa).

**2108.2.6.2.4 Reinforcement.** The nominal moment strength at any section along a member shall not be less than one fourth of the higher moment strength provided at the two ends of the member.

Lap splices shall be as defined in Section 2108.2.2.7. The center of the lap splice shall be at the center of the member clear length.

Welded splices and mechanical connections conforming to Section 1912.14.3, Items 1 through 4, may be used for splicing the reinforcement at any section provided not more than alternate longitudinal bars are spliced at a section, and the distance between splices of alternate bars is at least 24 inches (610 mm) along the longitudinal axis.

Reinforcement shall not have a specified yield strength greater than 60,000 psi (413 MPa). The actual yield strength based on mill tests shall not exceed the specified yield strength times 1.3.

**2108.2.6.2.5 Flexural members (beams).** Requirements of this subsection apply to beams proportioned primarily to resist flexure as follows:

The axial compressive force on beams due to factored loads shall not exceed  $0.10 A_n f'_m$ .

1. **Longitudinal reinforcement.** At any section of a beam, each masonry unit through the beam depth shall contain longitudinal reinforcement.

The variation in the longitudinal reinforcement area between units at any section shall not be greater than 50 percent, except multiple No. 4 bars shall not be greater than 100 percent of the minimum area of longitudinal reinforcement contained by any one unit, except where splices occur.

Minimum reinforcement ratio calculated over the gross cross section shall be 0.002.

Maximum reinforcement ratio calculated over the gross cross section shall be  $0.15f'_m / f_y$ .

2. **Transverse reinforcement.** Transverse reinforcement shall be hooked around top and bottom longitudinal bars with a standard 180-degree hook, as defined in Section 2108.2.2.4, and shall be single pieces.

Within an end region extending one beam depth from pier faces and at any region at which beam flexural yielding may occur during seismic or wind loading, maximum spacing of transverse reinforcement shall not exceed one fourth the nominal depth of the beam.

The maximum spacing of transverse reinforcement shall not exceed one half the nominal depth of the beam.

Minimum reinforcement ratio shall be 0.0015.

The first transverse bar shall not be more than 4 inches (102 mm) from the face of the pier.

#### 2108.2.6.2.6 Members subjected to axial force and flexure.

The requirements set forth in this subsection apply to piers proportioned to resist flexure in conjunction with axial loads.

1. **Longitudinal reinforcement.** A minimum of four longitudinal bars shall be provided at all sections of every pier.

Flexural reinforcement shall be distributed across the member depth. Variation in reinforcement area between reinforced cells shall not exceed 50 percent.

Minimum reinforcement ratio calculated over the gross cross section shall be 0.002.

Maximum reinforcement ratio calculated over the gross cross section shall be  $0.15f'_m / f_y$ .

Maximum bar diameter shall be one eighth nominal width of the pier.

2. **Transverse reinforcement.** Transverse reinforcement shall be hooked around the extreme longitudinal bars with standard 180-degree hook as defined in Section 2108.2.2.4.

Within an end region extending one pier depth from the end of the beam, and at any region at which flexural yielding may occur during seismic or wind loading, the maximum spacing of transverse reinforcement shall not exceed one fourth the nominal depth of the pier.

The maximum spacing of transverse reinforcement shall not exceed one half the nominal depth of the pier.

The minimum transverse reinforcement ratio shall be 0.0015.

3. **Lateral reinforcement.** Lateral reinforcement shall be provided to confine the grouted core when compressive strains due to axial and bending forces exceed 0.0015, corresponding to factored forces with  $R_w$  equal to 1.5. The unconfined portion of the cross section with strain exceeding 0.0015 shall be neglected in computing the nominal strength of the section.

The total cross-sectional area of rectangular tie reinforcement for the confined core shall not be less than:

$$A_{sh} = 0.09sh_c f'_m / f_{yh} \quad (8-49)$$

Alternatively, equivalent confinement which can develop an ultimate compressive strain of at least 0.006 may be substituted for rectangular tie reinforcement.

**2108.2.6.2.7 Pier design forces.** Pier nominal moment strength shall not be less than 1.6 times the pier moment corresponding to the development of beam plastic hinges, except at the foundation level.

Pier axial load based on the development of beam plastic hinges in accordance with the paragraph above and including factored dead and live loads shall not exceed  $0.15 A_n f'_m$ .

The drift ratio of piers shall satisfy the limits specified in Chapter 16.

The effects of cracking on member stiffness shall be considered. Unless stiffness values are obtained by a more comprehensive analysis, the effective moment of inertia shall be determined in accordance with Formula (8-50).

$$I_e = \left(\frac{M_{cr}}{M_a}\right)^3 I_{gt} + \left[1 - \left(\frac{M_{cr}}{M_a}\right)^3\right] I_{cr} \leq I_g \quad (8-50)$$

The base plastic hinge of the pier must form immediately adjacent to the level of lateral support provided at the base or foundation.

#### 2108.2.6.2.8 Shear design.

1. **General.** Beam and pier nominal shear strength shall not be less than 1.4 times the shears corresponding to the development of beam flexural yielding.

It shall be assumed in the calculation of member shear force that moments of opposite sign act at the joint faces and that the member is loaded with the tributary gravity load along its span.

2. **Vertical member shear strength.** The nominal shear strength shall be determined from Formula (8-51):

$$V_n = V_m + V_s \quad (8-51)$$

WHERE:

$$V_m = C_d A_{mv} \sqrt{f'_m} \quad (8-52)$$

For SI:

$$V_m = 0.083 C_d A_{mv} \sqrt{f'_m}$$

and

$$V_s = A_{mv} \rho_n f_y \quad (8-53)$$

The value of  $V_m$  shall be zero within an end region extending one pier depth from beam faces and at any region where pier flexural yielding may occur during seismic loading, and at piers subjected to net tension factored loads.

The nominal pier shear strength,  $V_n$ , shall not exceed the value determined from Table 21-J.

3. **Beam shear strength.** The nominal shear strength shall be determined from Formula (8-54),

WHERE:

$$V_m = 1.2 A_{mv} \sqrt{f'_m} \quad (8-54)$$

For SI:

$$V_m = 0.01 A_{mv} \sqrt{f'_m}$$

The value of  $V_m$  shall be zero within an end region extending one beam depth from pier faces and at any region at which beam flexural yielding may occur during seismic loading.

The nominal beam shear strength,  $V_n$ , shall be determined from Formula (8-55).

$$V_n \leq 4 A_{mv} \sqrt{f'_m} \quad (8-55)$$

For SI:

$$V_n \leq 0.33 A_{mv} \sqrt{f'_m}$$

#### 2108.2.6.2.9 Joints.

1. **General requirements.** Where reinforcing bars extend through a joint, the joint dimensions shall be proportioned such that

$$h_p > 4800 d_{bb} / \sqrt{f'_g} \quad (8-56)$$

For SI: 
$$h_p > 57\,827 d_{bb} / \sqrt{f'_g}$$
and

$$h_b > 1800 d_{bp} / \sqrt{f'_g} \quad (8-57)$$

For SI: 
$$h_b > 21\,685 d_{bp} / \sqrt{f'_g}$$

The grout strength shall not exceed 5,000 psi (34.4 MPa) for the purposes of Formulas (8-56) and (8-57).

Joint shear forces shall be calculated on the assumption that the stress in all flexural tension reinforcement of the beams at the pier faces is  $1.4 f_y$ .

Strength of joint shall be governed by the appropriate strength-reduction factors specified in Section 2108.1.4.4.

Beam longitudinal reinforcement terminating in a pier shall be extended to the far face of the pier and anchored by a standard 90- or 180-degree hook, as defined in Section 2108.2.2.4, bent back to the beam.

Pier longitudinal reinforcement terminating in a beam shall be extended to the far face of the beam and anchored by a standard 90- or 180-degree hook, as defined in Section 2108.2.2.4, bent back to the beam.

2. **Transverse reinforcement.** Special horizontal joint shear reinforcement crossing a potential corner-to-corner diagonal joint shear crack, and anchored by standard hooks, as defined in Section 2108.2.2.4, around the extreme pier reinforcing bars shall be provided such that

$$A_{jh} = 0.5 V_{jh} / f_y \quad (8-58)$$

Vertical shear forces may be considered to be carried by a combination of masonry shear-resisting mechanisms and truss mechanisms involving intermediate pier reinforcing bars.

3. **Shear strength.** The nominal horizontal shear strength of the joint shall not exceed  $7\sqrt{f'_m}$  (For SI:  $0.58\sqrt{f'_m}$ ) or 350 psi (2.4 MPa), whichever is less.

## SECTION 2109 — EMPIRICAL DESIGN OF MASONRY

**2109.1 General.** The design of masonry structures using empirical design located in those portions of Seismic Zones 0 and 1 as defined in Part III of Chapter 16 where the basic wind speed is less than 80 miles per hour as defined in Part II of Chapter 16 shall comply with the provisions of Section 2106 and this section, subject to approval of the building official.

**2109.2 Height.** Buildings relying on masonry walls for lateral load resistance shall not exceed 35 feet (10 668 mm) in height.

**2109.3 Lateral Stability.** Where the structure depends on masonry walls for lateral stability, shear walls shall be provided parallel to the direction of the lateral forces resisted.

Minimum nominal thickness of masonry shear walls shall not be less than 8 inches (203 mm).

In each direction in which shear walls are required for lateral stability, the minimum cumulative length of shear walls provided shall be 0.4 times the long dimension of the building. The cumulative length of shear walls shall not include openings.

The maximum spacing of shear walls shall not exceed the ratio listed in Table 21-L.

### 2109.4 Compressive Stresses.

**2109.4.1 General.** Compressive stresses in masonry due to vertical dead loads plus live loads, excluding wind or seismic loads, shall be determined in accordance with Section 2109.4.3. Dead and live loads shall be in accordance with this code with permitted live load reductions.

**2109.4.2 Allowable stresses.** The compressive stresses in masonry shall not exceed the values set forth in Table 21-M. The allowable stresses given in Table 21-M for the weakest combination of the units and mortar used in any load wythe shall be used for all loaded wythes of multiwythe walls.

**2109.4.3 Stress calculations.** Stresses shall be calculated based on specified rather than nominal dimensions. Calculated compressive stresses shall be determined by dividing the design load by the gross cross-sectional area of the member. The area of openings, chases or recesses in walls shall not be included in the gross cross-sectional area of the wall.

**2109.4.4 Anchor bolts.** Bolt values shall not exceed those set forth in Table 21-N.

**2109.5 Lateral Support.** Masonry walls shall be laterally supported in either the horizontal or vertical direction not exceeding the intervals set forth in Table 21-O.

Lateral support shall be provided by cross walls, pilasters, buttresses or structural framing members horizontally or by floors, roof or structural framing members vertically.

Except for parapet walls, the ratio of height to nominal thickness for cantilever walls shall not exceed 6 for solid masonry or 4 for hollow masonry.

In computing the ratio for cavity walls, the value of thickness shall be the sums of the nominal thickness of the inner and outer wythes of the masonry. In walls composed of different classes of units and mortars, the ratio of height or length to thickness shall not exceed that allowed for the weakest of the combinations of units and mortar of which the member is composed.

#### **2109.6 Minimum Thickness.**

**2109.6.1 General.** The nominal thickness of masonry bearing walls in buildings more than one story in height shall not be less than 8 inches (203 mm). Solid masonry walls in one-story buildings may be of 6-inch nominal thickness when not over 9 feet (2743 mm) in height, provided that when gable construction is used, an additional 6 feet (1829 mm) is permitted to the peak of the gable.

**EXCEPTION:** The thickness of unreinforced grouted brick masonry walls may be 2 inches (51 mm) less than required by this section, but in no case less than 6 inches (153 mm).

**2109.6.2 Variation in thickness.** Where a change in thickness due to minimum thickness occurs between floor levels, the greater thickness shall be carried up to the higher floor level.

**2109.6.3 Decrease in thickness.** Where walls of masonry of hollow units or masonry-bonded hollow walls are decreased in thickness, a course or courses of solid masonry shall be constructed between the walls below and the thinner wall above, or special units or construction shall be used to transmit the loads from face shells or wythes to the walls below.

**2109.6.4 Parapets.** Parapet walls shall be at least 8 inches (203 mm) in thickness and their height shall not exceed three times their thickness. The parapet wall shall not be thinner than the wall below.

**2109.6.5 Foundation walls.** Foundation walls shall be constructed with Type M or S mortar.

Where the height of unbalanced fill (height of finished grade above basement floor or inside grade) and the height of the wall between lateral support does not exceed 8 feet (2438 mm), and when the equivalent fluid weight of unbalanced fill does not exceed 30 pounds per cubic foot (480 kg/m<sup>2</sup>), the minimum thickness of foundation walls shall be as set forth in Table 21-P. Maximum depths of unbalanced fill permitted in Table 21-P may be increased with the approval of the building official when local soil conditions warrant such an increase.

Where the height of unbalanced fill, height between lateral supports or equivalent fluid weight of unbalanced fill exceeds that set forth above, foundation walls shall be designed in accordance with Chapter 18.

#### **2109.7 Bond.**

**2109.7.1 General.** The facing and backing of multiwythe masonry walls shall be bonded in accordance with this section.

**2109.7.2 Masonry headers.** Where the facing and backing of solid masonry construction are bonded by masonry headers, not less than 4 percent of the wall surface of each face shall be composed of headers extending not less than 3 inches (76 mm) into the backing. The distance between adjacent full-length headers shall not exceed 24 inches (610 mm) either vertically or horizontally. In walls in which a single header does not extend through the wall, headers from opposite sides shall overlap at least 3 inches (76 mm), or headers from opposite sides shall be covered with another header course overlapping the header below at least 3 inches (76 mm).

Where two or more hollow units are used to make up the thickness of the wall, the stretcher courses shall be bonded at vertical intervals not exceeding 34 inches (864 mm) by lapping at least 3 inches (76 mm) over the unit below, or by lapping at vertical intervals not exceeding 17 inches (432 mm) with units which are at least 50 percent greater in thickness than the units below.

**2109.7.3 Wall ties.** Where the facing and backing of masonry walls are bonded with  $\frac{3}{16}$ -inch-diameter (4.8 mm) wall ties or metal ties of equivalent stiffness embedded in the horizontal mortar joints, there shall be at least one metal tie for each  $4\frac{1}{2}$  square feet (0.42 m<sup>2</sup>) of wall area. Ties in alternate courses shall be staggered, the maximum vertical distance between ties shall not exceed 24 inches (610 mm), and the maximum horizontal distance shall not exceed 36 inches (914 mm). Rods bent to rectangular shape shall be used with hollow-masonry units laid with the cells vertical. In other walls, the ends of ties shall be bent to 90-degree angles to provide hooks not less than 2 inches (51 mm) long. Additional ties shall be provided at all openings, spaced not more than 3 feet (914 mm) apart around the perimeter and within 12 inches (305 mm) of the opening.

The facing and backing of masonry walls may be bonded with prefabricated joint reinforcement. There shall be at least one cross wire serving as a tie for each  $2\frac{2}{3}$  square feet (0.25 m<sup>2</sup>) of wall area. The vertical spacing of the joint reinforcement shall not exceed 16 inches (406 mm). Cross wires of prefabricated joint reinforcement shall be at least No. 9 gage wire. The longitudinal wire shall be embedded in mortar.

**2109.7.4 Longitudinal bond.** In each wythe of masonry, head joints in successive courses shall be offset at least one fourth of the unit length or the walls shall be reinforced longitudinally as required in Section 2106.1.12.3, Item 4.

### **2109.8 Anchorage.**

**2109.8.1 Intersecting walls.** Masonry walls depending on one another for lateral support shall be anchored or bonded at locations where they meet or intersect by one of the following methods:

1. Fifty percent of the units at the intersection shall be laid in an overlapping pattern, with alternating units having a bearing of not less than 3 inches (76 mm) on the unit below.

2. Walls shall be anchored by steel connectors having a minimum section of  $\frac{1}{4}$  inch by  $1\frac{1}{2}$  inches (6.4 mm by 38 mm) with ends bent up at least 2 inches (51 mm), or with cross pins to form anchorage. Such anchors shall be at least 24 inches (610 mm) long and the maximum spacing shall be 4 feet (1219 mm) vertically.

3. Walls shall be anchored by joint reinforcement spaced at a maximum distance of 8 inches (203 mm) vertically. Longitudinal rods of such reinforcement shall be at least No. 9 gage and shall extend at least 30 inches (762 mm) in each direction at the intersection.

4. Interior nonbearing walls may be anchored at their intersection, at vertical spacing of not more than 16 inches (406 mm) with joint reinforcement or  $\frac{1}{4}$ -inch (6.4 mm) mesh galvanized hardware cloth.

5. Other metal ties, joint reinforcement or anchors may be used, provided they are spaced to provide equivalent area of anchorage to that required by this section.

**2109.8.2 Floor and roof anchorage.** Floor and roof diaphragms providing lateral support to masonry walls shall be connected to the masonry walls by one of the following methods:

1. Wood floor joists bearing on masonry walls shall be anchored to the wall by approved metal strap anchors at intervals not exceeding 6 feet (1829 mm). Joists parallel to the wall shall be anchored with metal straps spaced not more than 6 feet (1829 mm) on center extending over and under and secured to at least three joists. Blocking shall be provided between joists at each strap anchor.

2. Steel floor joists shall be anchored to masonry walls with No. 3 bars, or their equivalent, spaced not more than 6 feet (1829 mm) on center. Where joists are parallel to the wall, anchors shall be located at joist cross bridging.

3. Roof structures shall be anchored to masonry walls with  $\frac{1}{2}$ -inch-diameter (13 mm) bolts at 6 feet (1829 mm) on center or their equivalent. Bolts shall extend and be embedded at least 15 inches (381 mm) into the masonry, or be hooked or welded to not less than 0.2 square inch (129 mm<sup>2</sup>) of bond beam reinforcement placed not less than 6 inches (153 mm) from the top of the wall.

**2109.8.3 Walls adjoining structural framing.** Where walls are dependent on the structural frame for lateral support, they shall be anchored to the structural members with metal anchors or keyed to the structural members. Metal anchors shall consist of  $\frac{1}{2}$ -inch-diameter (13 mm) bolts spaced at a maximum of 4 feet (1219 mm) on center and embedded at least 4 inches (102 mm) into the masonry, or their equivalent area.

#### **2109.9 Unburned Clay Masonry.**

**2109.9.1 General.** Masonry of stabilized unburned clay units shall not be used in any building more than one story in height. The unsupported height of every wall of unburned clay units shall not be more than 10 times the thickness of such walls. Bearing walls shall in no case be less than 16 inches (406 mm) in thickness. All footing walls which support masonry of unburned clay units shall extend to an elevation not less than 6 inches (153 mm) above the adjacent ground at all points.

**2109.9.2 Bolts.** Bolt values shall not exceed those set forth in Table 21-Q.

#### **2109.10 Stone Masonry.**

**2109.10.1 General.** Stone masonry is that form of construction made with natural or cast stone in which the units are laid and set in mortar with all joints filled.

**2109.10.2 Construction.** In ashlar masonry, bond stones uniformly distributed shall be provided to the extent of not less than 10 percent of the area of exposed facets. Rubble stone masonry 24 inches (610 mm) or less in thickness shall have bond stones with a maximum spacing of 3 feet (914 mm) vertically and 3 feet (914 mm) horizontally and, if the masonry is of greater thickness than 24 inches (610 mm), shall have one bond stone for each 6 square feet (0.56 m<sup>2</sup>) of wall surface on both sides.

**2109.10.3 Minimum thickness.** The thickness of stone masonry bearing walls shall not be less than 16 inches (406 mm).

### **SECTION 2110 — GLASS MASONRY**

**2110.1 General.** Masonry of glass blocks may be used in nonload-bearing exterior or interior walls and in openings which might otherwise be filled with windows, either isolated or in continuous bands, provided the glass block panels have a minimum thickness of 3 inches (76 mm) at the mortar joint and the mortared surfaces of the blocks are treated for mortar bonding. Glass block may be solid or hollow and may contain inserts.

**2110.2 Mortar Joints.** Glass block shall be laid in Type S or N mortar. Both vertical and horizontal mortar joints shall be at least  $\frac{1}{4}$  inch (6 mm) and not more than  $\frac{3}{8}$  inch (10 mm) thick and shall be completely filled. All mortar contact surfaces shall be treated to ensure adhesion between mortar and glass.

**2110.3 Lateral Support.** Glass panels shall be laterally supported along each end of the panel.

Lateral support shall be provided by panel anchors spaced not more than 16 inches (406 mm) on center or by channels. The lateral support shall be capable of resisting the horizontal design forces determined in Chapter 16 or a minimum of 200 pounds per lineal foot (2920 N per linear meter) of wall, whichever is greater. The connection shall accommodate movement requirements of Section 2110.6.

**2110.4 Reinforcement.** Glass block panels shall have joint reinforcement spaced not more than 16 inches (406 mm) on center and located in the mortar bed joint extending the entire length of the panel. A lapping of longitudinal wires for a minimum of 6 inches (153 mm) is required for joint reinforcement splices. Joint reinforcement shall also be placed in the bed joint immediately below and above openings in the panel. Joint reinforcement shall conform to U.B.C. Standard 21-10, Part I. Joint reinforcement in exterior panels shall be hot-dip galvanized in accordance with U.B.C. Standard 21-10, Part I.

**2110.5 Size of Panels.** Glass block panels for exterior walls shall not exceed 144 square feet (13.4 m<sup>2</sup>) of unsupported wall surface or 15 feet (4572 mm) in any dimension. For interior walls, glass block panels shall not exceed 250 square feet (23.2 m<sup>2</sup>) of unsupported area or 25 feet (7620 mm) in any dimension.

**2110.6 Expansion Joints.** Glass block shall be provided with expansion joints along the sides and top, and these joints shall have sufficient thickness to accommodate displacements of the supporting structure, but not less than  $\frac{3}{8}$  inch (19.5 mm). Expansion joints shall be entirely free of mortar and shall be filled with resilient material.

**2110.7 Reuse of Units.** Glass block units shall not be reused after being removed from an existing panel.

## SECTION 2111 — CHIMNEYS, FIREPLACES AND BARBECUES

Chimneys, flues, fireplaces and barbecues and their connections carrying products of combustion shall be designed, anchored, supported and reinforced as set forth in Chapter 31 and any applicable provisions of this chapter.

TABLE 21-A—MORTAR PROPORTIONS FOR UNIT MASONRY

MORTAR	TYPE	PROPORTIONS BY VOLUME (CEMENTITIOUS MATERIALS)							AGGREGATE MEASURED IN A DAMP, LOOSE CONDITION	
		Portland Cement or Blended Cement	Masonry Cement <sup>1</sup>			Mortar Cement <sup>2</sup>				Hydrated Lime or Lime Putty
			M	S	N	M	S	N		
Cement-lime	M	1	—	—	—	—	—	—	$\frac{1}{4}$ over $\frac{1}{4}$ to $\frac{1}{2}$ over $\frac{1}{2}$ to $1\frac{1}{4}$ over $1\frac{1}{4}$ to $2\frac{1}{2}$	
	S	1	—	—	—	—	—	—		
	N	1	—	—	—	—	—	—		
	O	1	—	—	—	—	—	—		
Mortar cement	M	1	—	—	—	—	—	1	Not less than $2\frac{1}{4}$ and not more than 3 times the sum of the separate volumes of cementitious materials.	
	M	$\frac{1}{2}$	—	—	—	1	—	—		
	S	—	—	—	—	—	1	—		
	N	—	—	—	—	—	—	1		
Masonry cement	M	1	—	—	1	—	—	—		
	M	$\frac{1}{2}$	1	—	$\frac{1}{2}$	—	—	—		
	S	—	—	1	—	—	—	—		
	S	—	—	—	1	—	—	—		
	O	—	—	—	—	1	—	—		

<sup>1</sup>Masonry cement conforming to the requirements of U.B.C. Standard 21-11.

<sup>2</sup>Mortar cement conforming to the requirements of U.B.C. Standard 21-14.

TABLE 21-B—GROUT PROPORTIONS BY VOLUME<sup>1</sup>

TYPE	PARTS BY VOLUME OF PORTLAND CEMENT OR BLENDED CEMENT	PARTS BY VOLUME OF HYDRATED LIME OR LIME PUTTY	AGGREGATE MEASURED IN A DAMP, LOOSE CONDITION	
			Fine	Coarse
Fine grout	1	0 to $\frac{1}{10}$	$2\frac{1}{4}$ to 3 times the sum of the volumes of the cementitious materials	
Coarse grout	1	0 to $\frac{1}{10}$	$2\frac{1}{4}$ to 3 times the sum of the volumes of the cementitious materials	1 to 2 times the sum of the volumes of the cementitious materials

<sup>1</sup>Grout shall attain a minimum compressive strength at 28 days of 2,000 psi (13.8 MPa). The building official may require a compressive field strength test of grout made in accordance with U.B.C. Standard 21-18.

TABLE 21-C—GROUTING LIMITATIONS

GROUT TYPE	GROUT POUR MAXIMUM HEIGHT (feet) <sup>1</sup>	MINIMUM DIMENSIONS OF THE TOTAL CLEAR AREAS WITHIN GROUT SPACES AND CELLS <sup>2,3</sup>	
		× 25.4 for mm	
		× 304.8 for mm	
		Multiwythe Masonry	Hollow-unit Masonry
Fine	1	$\frac{3}{4}$	$1\frac{1}{2} \times 2$
Fine	5	$1\frac{1}{2}$	$1\frac{1}{2} \times 2$
Fine	8	$1\frac{1}{2}$	$1\frac{1}{2} \times 3$
Fine	12	$1\frac{1}{2}$	$1\frac{3}{4} \times 3$
Fine	24	2	3 × 3
Coarse	1	$1\frac{1}{2}$	$1\frac{1}{2} \times 3$
Coarse	5	2	$2\frac{1}{2} \times 3$
Coarse	8	2	3 × 3
Coarse	12	$2\frac{1}{2}$	3 × 3
Coarse	24	3	3 × 4

<sup>1</sup>See also Section 2104.6.

<sup>2</sup>The actual grout space or grout cell dimensions must be larger than the sum of the following items: (1) The required minimum dimensions of total clear areas in Table 21-C; (2) The width of any mortar projections within the space; and (3) The horizontal projections of the diameters of the horizontal reinforcing bars within a cross section of the grout space or cell.

<sup>3</sup>The minimum dimensions of the total clear areas shall be made up of one or more open areas, with at least one area being  $\frac{3}{4}$  inch (19 mm) or greater in width.

**TABLE 21-D—SPECIFIED COMPRESSIVE STRENGTH OF MASONRY,  $f'_m$  (psi) BASED ON SPECIFYING THE COMPRESSIVE STRENGTH OF MASONRY UNITS**

COMPRESSIVE STRENGTH OF CLAY MASONRY UNITS <sup>1,2</sup> (psi)	SPECIFIED COMPRESSIVE STRENGTH OF MASONRY, $f'_m$	
	Type M or S Mortar <sup>3</sup> (psi)	Type N Mortar <sup>3</sup> (psi)
× 6.89 for kPa		
14,000 or more	5,300	4,400
12,000	4,700	3,800
10,000	4,000	3,300
8,000	3,350	2,700
6,000	2,700	2,200
4,000	2,000	1,600
COMPRESSIVE STRENGTH OF CONCRETE MASONRY UNITS <sup>2,4</sup> (psi)	SPECIFIED COMPRESSIVE STRENGTH OF MASONRY, $f'_m$	
	Type M or S Mortar <sup>3</sup> (psi)	Type N Mortar <sup>3</sup> (psi)
× 6.89 for kPa		
4,800 or more	3,000	2,800
3,750	2,500	2,300
2,800	2,000	1,800
1,900	1,500	1,300
1,250	1,000	900

<sup>1</sup>Compressive strength of solid clay masonry units is based on gross area. Compressive strength of hollow clay masonry units is based on minimum net area. Values may be interpolated. When hollow clay masonry units are grouted, the grout shall conform to the proportions in Table 21-B.

<sup>2</sup>Assumed assemblage. The specified compressive strength of masonry  $f'_m$  is based on gross area strength when using solid units or solid grouted masonry and net area strength when using ungrouted hollow units.

<sup>3</sup>Mortar for unit masonry, proportion specification, as specified in Table 21-B. These values apply to portland cement-lime mortars without added air-entraining materials.

<sup>4</sup>Values may be interpolated. In grouted concrete masonry, the compressive strength of grout shall be equal to or greater than the compressive strength of the concrete masonry units.

**TABLE 21-E-1—ALLOWABLE TENSION,  $B_t$ , FOR EMBEDDED ANCHOR BOLTS FOR CLAY AND CONCRETE MASONRY, pounds<sup>1,2,3</sup>**

$f'_m$ (psi)	EMBEDMENT LENGTH, $l_b$ , or EDGE DISTANCE, $l_{be}$ (Inches)						
	2	3	4	5	6	8	10
× 6.89 for kPa	× 25.4 for mm × 4.45 for N						
1,500	240	550	970	1,520	2,190	3,890	6,080
1,800	270	600	1,070	1,670	2,400	4,260	6,660
2,000	280	630	1,120	1,760	2,520	4,500	7,020
2,500	310	710	1,260	1,960	2,830	5,030	7,850
3,000	340	770	1,380	2,150	3,100	5,510	8,600
4,000	400	890	1,590	2,480	3,580	6,360	9,930
5,000	440	1,000	1,780	2,780	4,000	7,110	11,100
6,000	480	1,090	1,950	3,040	4,380	7,790	12,200

<sup>1</sup>The allowable tension values in Table 21-E-1 are based on compressive strength of masonry assemblages. Where yield strength of anchor bolt steel governs, the allowable tension in pounds is given in Table 21-E-2.

<sup>2</sup>Values are for bolts of at least A 307 quality. Bolts shall be those specified in Section 2106.2.14.1.

<sup>3</sup>Values shown are for work with or without special inspection.

**TABLE 21-E-2—ALLOWABLE TENSION,  $B_t$ , FOR EMBEDDED ANCHOR BOLTS FOR CLAY AND CONCRETE MASONRY, pounds<sup>1,2</sup>**

BENT BAR ANCHOR BOLT DIAMETER (Inches)							
× 25.4 for mm							
1/4	3/8	1/2	5/8	3/4	7/8	1	1 1/8
× 4.45 for N							
350	790	1,410	2,210	3,180	4,330	5,650	7,160

<sup>1</sup>Values are for bolts of at least A 307 quality. Bolts shall be those specified in Section 2105.2.14.1.  
<sup>2</sup>Values shown are for work with or without special inspection.

**TABLE 21-F—ALLOWABLE SHEAR,  $B_v$ , FOR EMBEDDED ANCHOR BOLTS FOR CLAY AND CONCRETE MASONRY, pounds<sup>1,2</sup>**

$f'_m$ (psi)	BENT BAR ANCHOR BOLT DIAMETER (Inches)						
	× 25.4 for mm						
	3/8	1/2	5/8	3/4	7/8	1	1 1/8
× 4.45 for N							
1,500	480	850	1,330	1,780	1,920	2,050	2,170
1,800	480	850	1,330	1,860	2,010	2,150	2,280
2,000	480	850	1,330	1,900	2,060	2,200	2,340
2,500	480	850	1,330	1,900	2,180	2,330	2,470
3,000	480	850	1,330	1,900	2,280	2,440	2,590
4,000	480	850	1,330	1,900	2,450	2,520	2,780
5,000	480	850	1,330	1,900	2,590	2,770	2,940
6,000	480	850	1,330	1,900	2,600	2,900	3,080

<sup>1</sup>Values are for bolts of at least A 307 quality. Bolts shall be those specified in Section 2106.2.14.1.  
<sup>2</sup>Values shown are for work with or without special inspection.

**TABLE 21-G—MINIMUM DIAMETERS OF BEND**

BAR SIZE	MINIMUM DIAMETER
No. 3 through No. 8 No. 9 through No. 11	6 bar diameters 8 bar diameters

**TABLE 21-H-1—RADIUS OF GYRATION<sup>1</sup> FOR CONCRETE MASONRY UNITS<sup>2</sup>**

Grout Spacing (Inches)	Nominal Width of Wall (Inches)				
	× 25.4 for mm				
	4	6	8	10	12
Solid grouted	1.04	1.62	2.19	2.77	3.34
16	1.16	1.79	2.43	3.04	3.67
24	1.21	1.87	2.53	3.17	3.82
32	1.24	1.91	2.59	3.25	3.91
40	1.26	1.94	2.63	3.30	3.97
48	1.27	1.96	2.66	3.33	4.02
56	1.28	1.98	2.68	3.36	4.05
64	1.29	1.99	2.70	3.38	4.08
72	1.30	2.00	2.71	3.40	4.10
No grout	1.35	2.08	2.84	3.55	4.29

<sup>1</sup>For single-wythe masonry or for an individual wythe of a cavity wall.

$$r = \sqrt{I/A_e}$$

<sup>2</sup>The radius of gyration shall be based on the specified dimensions of the masonry units or shall be in accordance with the values shown which are based on the minimum dimensions of hollow concrete masonry unit face shells and webs in accordance with U.B.C. Standard 21-4 for two cell units.

**TABLE 21-H-2—RADIUS OF GYRATION<sup>1</sup> FOR CLAY MASONRY UNIT LENGTH, 16 INCHES<sup>2</sup>**

Grout Spacing (Inches)	Nominal Width of Wall (Inches)				
	× 25.4 for mm				
	4	6	8	10	12
× 25.4 for mm					
Solid grouted	1.06	1.64	2.23	2.81	3.39
16	1.16	1.78	2.42	3.03	3.65
24	1.20	1.85	2.51	3.13	3.77
32	1.23	1.88	2.56	3.19	3.85
40	1.25	1.91	2.59	3.23	3.90
48	1.26	1.93	2.61	3.26	3.93
56	1.27	1.94	2.63	3.28	3.95
64	1.27	1.95	2.64	3.30	3.97
72	1.28	1.95	2.65	3.31	3.99
No grout	1.32	2.02	2.75	3.42	4.13

<sup>1</sup>For single-wythe masonry or for an individual wythe of a cavity wall.

$$r = \sqrt{I/A_e}$$

<sup>2</sup>The radius of gyration shall be based on the specified dimensions of the masonry units or shall be in accordance with the values shown which are based on the minimum dimensions of hollow clay masonry face shells and webs in accordance with U.B.C. Standard 21-1 for two cell units.

**TABLE 21-H-3—RADIUS OF GYRATION<sup>1</sup> FOR CLAY MASONRY UNIT LENGTH, 12 INCHES<sup>2</sup>**

Grout Spacing (Inches)	Nominal Width of Wall (Inches)				
	× 25.4 for mm				
	4	6	8	10	12
× 25.4 for mm					
Solid grouted	1.06	1.65	2.24	2.82	3.41
12	1.15	1.77	2.40	3.00	3.61
18	1.19	1.82	2.47	3.08	3.71
24	1.21	1.85	2.51	3.12	3.76
30	1.23	1.87	2.53	3.15	3.80
36	1.24	1.88	2.55	3.17	3.82
42	1.24	1.89	2.56	3.19	3.84
48	1.25	1.90	2.57	3.20	3.85
54	1.25	1.90	2.58	3.21	3.86
60	1.26	1.91	2.59	3.21	3.87
66	1.26	1.91	2.59	3.22	3.88
72	1.26	1.91	2.59	3.22	3.88
No grout	1.29	1.95	2.65	3.28	3.95

<sup>1</sup>For single-wythe masonry or for an individual wythe of a cavity wall.

$$r = \sqrt{I/A_e}$$

<sup>2</sup>The radius of gyration shall be based on the specified dimensions of the masonry units or shall be in accordance with the values shown which are based on the minimum dimensions of hollow clay masonry face shells and webs in accordance with U.B.C. Standard 21-1 for two cell units.

**TABLE 21-I—ALLOWABLE FLEXURAL TENSION (psi)**

UNIT TYPE	MORTAR TYPE			
	Cement-Lime and Mortar Cement		Masonry Cement	
	M or S	N	M or S	N
	× 6.89 for kPa			
Normal to bed joints				
Solid	40	30	24	15
Hollow	25	19	15	9
Normal to head joints				
Solid	80	60	48	30
Hollow	50	38	30	18

**TABLE 21-J—MAXIMUM NOMINAL SHEAR STRENGTH VALUES<sup>1,2</sup>**

M/Vd	V <sub>n</sub> MAXIMUM
≤ 0.25	6.0 √f' <sub>m</sub> = 380 maximum (322 √f' <sub>m</sub> = 1691 maximum)
≥ 1.00	4.0 √f' <sub>m</sub> = 250 maximum (214 √f' <sub>m</sub> = 1113 maximum)

<sup>1</sup>M is the maximum bending moment that occurs simultaneously with the shear load V at the section under consideration. Interpolation may be by straight line for M/Vd values between 0.25 and 1.00.

<sup>2</sup>V<sub>n</sub> is in pounds (N), and f'<sub>m</sub> is in pounds per square inches (kPa).

**TABLE 21-K—NOMINAL SHEAR STRENGTH COEFFICIENT**

M/Vd <sup>1</sup>	C <sub>d</sub>
≤ 0.25	2.4
≥ 1.00	1.2

<sup>1</sup>M is the maximum bending moment that occurs simultaneously with the shear load V at the section under consideration. Interpolation may be by straight line for M/Vd values between 0.25 and 1.00.

**TABLE 21-L—SHEAR WALL SPACING REQUIREMENTS FOR EMPIRICAL DESIGN OF MASONRY**

FLOOR OR ROOF CONSTRUCTION	MAXIMUM RATIO
	Shear Wall Spacing to Shear Wall Length
Cast-in-place concrete	5:1
Precast concrete	4:1
Metal deck with concrete fill	3:1
Metal deck with no fill	2:1
Wood diaphragm	2:1

TABLE 21-M—ALLOWABLE COMPRESSIVE STRESSES FOR EMPIRICAL DESIGN OF MASONRY

CONSTRUCTION: COMPRESSIVE STRENGTH OF UNIT, GROSS AREA	ALLOWABLE COMPRESSIVE STRESSES <sup>1</sup> GROSS CROSS-SECTIONAL AREA (psi)	
	× 6.89 for kPa	
× 6.89 for kPa	Type M or S Mortar	Type N Mortar
Solid masonry of brick and other solid units of clay or shale; sand-lime or concrete brick:		
8,000 plus, psi	350	300
4,500 psi	225	200
2,500 psi	160	140
1,500 psi	115	100
Grouted masonry, of clay or shale; sand-lime or concrete:		
4,500 plus, psi	275	200
2,500 psi	215	140
1,500 psi	175	100
Solid masonry of solid concrete masonry units:		
3,000 plus, psi	225	200
2,000 psi	160	140
1,200 psi	115	100
Masonry of hollow load-bearing units:		
2,000 plus, psi	140	120
1,500 psi	115	100
1,000 psi	75	70
700 psi	60	55
Hollow walls (cavity or masonry bonded) <sup>2</sup> solid units:		
2,500 plus, psi	160	140
1,500 psi	115	100
Hollow units	75	70
Stone ashlar masonry:		
Granite	720	640
Limestone or marble	450	400
Sandstone or cast stone	360	320
Rubble stone masonry		
Coarse, rough or random	120	100
Unburned clay masonry	30	—

<sup>1</sup>Linear interpolation may be used for determining allowable stresses for masonry units having compressive strengths which are intermediate between those given in the table.

<sup>2</sup>Where floor and roof loads are carried upon one wythe, the gross cross-sectional area is that of the wythe under load. If both wythes are loaded, the gross cross-sectional area is that of the wall minus the area of the cavity between the wythes.

**TABLE 21-N—ALLOWABLE SHEAR ON BOLTS FOR EMPIRICALLY DESIGNED MASONRY EXCEPT UNBURNED CLAY UNITS**

DIAMETER BOLT (inches)	EMBEDMENT <sup>1</sup> (inches)	SOLID MASONRY (shear in pounds)	GROUTED MASONRY (shear in pounds)
× 25.4 for mm		× 4.45 for N	
1/2	4	350	550
5/8	4	500	750
3/4	5	750	1,100
7/8	6	1,000	1,500
1	7	1,250	1,850 <sup>2</sup>
1 1/8	8	1,500	2,250 <sup>2</sup>

<sup>1</sup>An additional 2 inches of embedment shall be provided for anchor bolts located in the top of columns for buildings located in Seismic Zones 2, 3 and 4.

<sup>2</sup>Permitted only with not less than 2,500 pounds per square inch (17.24 MPa) units.

**TABLE 21-O—WALL LATERAL SUPPORT REQUIREMENTS FOR EMPIRICAL DESIGN OF MASONRY**

CONSTRUCTION	MAXIMUM $l/t$ or $h/t$
Bearing walls	
Solid or solid grouted	20
All other	18
Nonbearing walls	
Exterior	18
Interior	36

**TABLE 21-P—THICKNESS OF FOUNDATION WALLS FOR EMPIRICAL DESIGN OF MASONRY**

FOUNDATION WALL CONSTRUCTION	NOMINAL THICKNESS (inches)	MAXIMUM DEPTH OF UNBALANCED FILL (feet)
	× 25.4 for mm	× 304.8 for mm
Masonry of hollow units, ungrouted	8	4
	10	5
	12	6
Masonry of solid units	8	5
	10	6
	12	7
Masonry of hollow or solid units, fully grouted	8	7
	10	8
	12	8
Masonry of hollow units reinforced vertically with No.4 bars and grout at 24" o.c. Bars located not less than 4 1/2" from pressure side of wall.	8	7

**TABLE 21-Q—ALLOWABLE SHEAR ON BOLTS FOR MASONRY OF UNBURNED CLAY UNITS**

DIAMETER OF BOLTS (inches)	EMBEDMENTS (inches)	SHEAR (pounds)
× 25.4 for mm		× 4.45 for N
1/2	—	—
5/8	12	200
3/4	15	300
7/8	18	400
1	21	500
1 1/8	24	600

## Chapter 22 STEEL

### Division I—GENERAL

#### SECTION 2201 — SCOPE

The quality, testing and design of steel used structurally in buildings or structures shall conform to the requirements specified in this chapter.

#### SECTION 2202 — DESIGN AND IDENTIFICATION OF STEEL FOR STRUCTURES

**2202.1 Standards of Quality.** The standards listed below labeled a “U.B.C. standard” are also listed in Chapter 35, Part II, and are part of this code. The other standards listed below are recognized standards. (See Sections 3502 and 3503.)

1. **Material specifications.**

U.B.C. Standard 22-1, Material Specifications for Structural Steel

2. **Design.**

2.1 ANSI/ASCE 8, Specification for the Design of Cold-formed Stainless Steel Structural Members, American Society of Civil Engineers

2.2 AISC Seismic Provisions for Structural Steel Buildings

3. **Connectors.**

ASTM A 502, Structural Rivet Steel

#### 2202.2 Identification.

**2202.2.1 General.** Steel furnished for structural load-carrying purposes shall be properly identified for conformity to the ordered grade in accordance with approved national standards, the provisions of this chapter and the appropriate U.B.C. standards. Steel which is not readily identifiable as to grade from marking and test records shall be tested to determine conformity to such standards.

**2202.2.2 Structural steel.** Structural steel shall be identified by the mill in accordance with approved national standards. When such steel is furnished to a specified minimum yield point greater than 36,000 pounds per square inch (psi) (248 MPa), the American Society for Testing and Materials (ASTM) or other specification designation shall be so indicated.

The fabricator shall maintain identity of the material and shall maintain suitable procedures and records attesting that the specified grade has been furnished in conformity with the applicable standard. The fabricator’s identification mark system shall be established and on record prior to fabrication.

When structural steel is furnished to a specified minimum yield point greater than 36,000 psi (248 MPa), the ASTM or other specification designation shall be included near the erection mark on each shipping assembly or important construction component over any shop coat of paint prior to shipment from the fabricator’s plant. Pieces of such steel which are to be cut to smaller sizes shall, before cutting, be legibly marked with the fabricator’s identification mark on each of the smaller-sized pieces to provide continuity of identification. When subject to fabrication operations, prior to assembling into members, which might obliterate paint marking, such as blast cleaning, galvanizing or heating for forming, such pieces of steel shall be marked by steel die stamping or by a substantial tag firmly attached.

Individual pieces of steel having a minimum specified yield point in excess of 36,000 psi (248 MPa), which are received by the fabricator in a tagged bundle or lift or which have only the top

shape or plate in the bundle or lift marked by the mill shall be marked by the fabricator prior to use in accordance with the fabricator's established identification marking system.

**2202.2.3 Cold-formed carbon and low-alloy steel.** Cold-formed carbon and low-alloy steel used for structural purposes shall be identified by the mill in accordance with approved national standards. When such steel is furnished to a specified minimum yield point greater than 33,000 psi (228 MPa), the fabricator shall indicate the ASTM or other specification designation, by painting, decal, tagging or other suitable means, on each lift or bundle of fabricated elements.

When cold-formed carbon and low-alloy steel used for structural purposes has a specified yield point equal to or greater than 33,000 psi (228 MPa), which was obtained through additional treatment, the resulting minimum yield point shall be identified in addition to the specification designation.

**2202.2.4 Cold-formed stainless steel.** Cold-formed stainless steel structural members designed in accordance with recognized standards shall be identified as to grade through mill test reports. See reference to ANSI/ASCE 8-90 in U.B.C. Chapter 35. A certification shall be furnished that the chemical and mechanical properties of the material supplied equals or exceeds that considered in the design. Each lift or bundle of fabricated elements shall be identified by painting, decal, tagging or other suitable means.

**2202.2.5 Open-web steel joists.** Open-web steel joists and similar fabricated light steel load-carrying members shall be identified in accordance with Division III as to type, size and manufacturer by tagging or other suitable means at the time of manufacture or fabrication. Such identification shall be maintained continuously to the point of their installation in a structure.

## **SECTION 2203 — STRUCTURAL STEEL CONSTRUCTION**

The design, fabrication and erection of structural steel shall be in accordance with the requirements of Division VIII (LRFD) or Division IX (ASD). Seismic design of structures, where required, shall comply with the following:

Section 2211 or 2212 for structures designed in accordance with Division IX (ASD) or approved national standards.

## **SECTION 2204 — COLD-FORMED CARBON AND LOW-ALLOY STEEL CONSTRUCTION**

The design of cold-formed carbon or low-alloy steel structural members shall be in accordance with the requirements of Division V or X.

## **SECTION 2205 — COLD-FORMED STAINLESS STEEL CONSTRUCTION**

The design of cold-formed stainless steel structural members shall be in accordance with approved national standards. (See Section 2202.)

## **SECTION 2206 — OPEN-WEB STEEL JOISTS AND JOIST GIRDERS**

The design, manufacture and use of steel joist, K, LH and KLH series and joist girders shall be in accordance with Division III.

## **SECTION 2207 — STEEL STORAGE RACKS**

Steel storage racks may be designed in accordance with the provisions of Division VI, except that in Seismic Zones 3 and 4, wholesale and retail sales areas, the  $W$  used in the design of racks over 8 feet

(2438 mm) in height shall be equal to the weight of the rack structure and contents with no reductions.

### SECTION 2208 — STEEL CABLES

Structural applications of steel cables for buildings shall be in accordance with the provisions of Division VII.

### SECTION 2209 — WELDING

Welding procedures, welder qualification requirements and welding electrodes shall be in accordance with Divisions V, VIII and IX or X and approved national standards.

### SECTION 2210 — BOLTS

The use of high-strength A 325 and A 490 bolts shall be in accordance with the requirements of Division IV.

Anchor bolts shall be set accurately to the pattern and dimensions called for on the plans. The protrusion of the threaded ends through the connected material shall be sufficient to fully engage the threads of the nuts, but shall not be greater than the length of threads on the bolts. Base plate holes for anchor bolts may be oversized as follows:

Bolt Size, inches (mm)	Hole Size, inches (mm)
$\frac{3}{4}$ (19.1)	$\frac{5}{16}$ (7.9) oversized
$\frac{7}{8}$ (22.2)	$\frac{5}{16}$ (7.9) oversized
1 < 2 (25.4 < 50.8)	$\frac{1}{2}$ (12.7) oversized
>2 (> 50.8)	1 (25.4) > bolt diameter

### SECTION 2211 — STEEL STRUCTURES RESISTING FORCES INDUCED BY EARTHQUAKE MOTIONS IN SEISMIC ZONES 3 AND 4

**2211.1 General.** Design and construction of steel framing in lateral-force-resisting systems in Seismic Zones 3 and 4 shall conform to the requirements of the code and to the requirements of this section.

#### 2211.2 Definitions.

**ALLOWABLE STRESSES** are prescribed in Divisions V and IX.

**CHEVRON BRACING** is that form of bracing where a pair of braces located either above or below a beam terminates at a single point within the clear beam span.

**CONNECTION** is the group of elements that connect the member to the joint.

**DIAGONAL BRACING** is that form of bracing that diagonally connects joints at different levels.

**ECCENTRICALLY BRACED FRAME (EBF)** is a diagonal braced frame in which at least one end of each bracing member connects to a beam a short distance from a beam-to-column connection or from another beam-to-brace connection.

**GIRDER** is the horizontal member in a seismic frame. The words beam and girder may be used interchangeably.

**JOINT** is the entire assemblage at the intersections of the members.

**K BRACING** is that form of bracing where a pair of braces located on one side of a column terminates at a single point within the clear column height.

**LINK BEAM** is that part of a beam in an eccentrically braced frame which is designed to yield in shear and/or bending so that buckling of the bracing members is prevented.

**STRENGTH** is the strength as prescribed in Section 2211.4.2.

**V BRACING** is that form of chevron bracing that intersects a beam from above and inverted V bracing is that form of chevron bracing that intersects a beam from below.

**X BRACING** is that form of bracing where a pair of diagonal braces cross near midlength of the bracing members.

**2211.3 Symbols and Notations.** The symbols and notations unique to this section are as follows:

- $M_s$  = flexural strength.
- $P_{DL}$  = axial dead load.
- $P_E$  = axial load on member due to earthquake.
- $P_{LL}$  = axial live load.
- $P_{sc}$  = compressive axial strength of member.
- $P_{st}$  = tensile axial strength of member.
- $V_s$  = shear strength of member.
- $Z$  = plastic section modulus.

#### 2211.4 Materials.

**2211.4.1 Quality.** Structural steel used in lateral-force-resisting systems shall conform to A 36, A 500, A 501, A 572 (Grades 42 and 50) and A 588. Structural steel conforming to A 283 (Grade D) may be used for base plates and anchor bolts.

**EXCEPTION:** Other steels permitted in this code may be used for the following:

1. One-story buildings.
2. Light-framed wall systems in accordance with Section 2211.10.

**2211.4.2 Member strength.** Where this section requires that the strength of the member be developed, the following shall be used:

	<b>Strength</b>
Flexure	$M_s = ZF_y$
Shear	$V_s = 0.55 F_y dt$
Axial compression	$P_{sc} = 1.7 F_y A$
Axial tension	$P_{st} = F_y A$
Connectors	
Full-penetration welds	$F_y A$
Partial penetration welds	1.7 allowable
Bolts and fillet welds	1.7 allowable

Members need not be compact unless otherwise required by this section.

#### 2211.5 Column Requirements.

**2211.5.1 Column strength.** Columns shall satisfy the load combinations required by Section 1603.6 at allowable stress limits, with stress increases allowed by Section 1603.5. In addition, in Seismic Zones 3 and 4, columns in frames shall have the strength to resist the axial loads resulting from the load combinations in Items 1 and 2 following.

**1. Axial compression**

$$1.0 P_{DL} + 0.7 P_{LL} + 3(R_w/8)P_E$$

**2. Axial tension**

$$0.85 P_{DL} \pm 3(R_w/8)P_E$$

**EXCEPTION:** The axial load combination as outlined in Items 1 and 2 above:

1. Need not exceed either the maximum force that can be transferred to the column by elements of the structure, or the limit as determined by the overturning uplift which the foundation is capable of resisting.

2. Need not apply to columns in moment-resisting frames complying with Formula (11-3.1) or (11-3.2) where  $f_a$  is equal to or less than  $0.3 F_y$  for all load combinations.

The load combinations from Items 1 and 2 need be used only when specifically referred to.

**2211.5.2 Column splices.** Column splices shall have sufficient strength to develop the column forces determined from Section 2211.5.1. Welded column splices subject to net tensile forces shall comply with the more critical of the following:

1. Partial penetration welds shall be designed to resist 150 percent of the force determined from Section 2211.5.1, Item 2.
2. Welding shall develop not less than 50 percent of the flange area strength of the smaller column.

Splices employing partial penetration welds shall be located at least three feet (914 mm) from girder flanges.

**2211.5.3 Slenderness evaluation.** This paragraph is applicable when the provisions are applied to the effective length determination of columns of moment frames resisting earthquake forces. In the plane of the earthquake forces the factor  $K$  may be taken as unity when all of the following conditions are met:

1. The column is either continuous or is fixed at each joint.
2. The maximum axial compressive stress,  $f_a$ , does not exceed  $0.4 F_y$  under design loads.
3. The calculated story drift ratios are less than the values given in Section 1628.8.

**2211.6 Ordinary Moment Frame Requirements.** Ordinary moment frames (OMF) shall be designed to resist the load combinations in Section 1603.6.

All beam-to-column connections in OMFs which resist earthquake forces shall meet one of the following requirements:

1. Fully restrained (Type F.R. or Type 1) conforming with Section 2211.7.1.
2. Fully restrained (Type F.R. or Type 1) connections with the design strengths of the connections capable of resisting a combination of gravity loads and  $3 (R_w/8)$  times the design seismic forces.
3. Partially restrained (Type P.R. or Type 3) connections are permitted provided:
  - 3.1 The connections are designed to resist the load combinations in Section 1603.6, and
  - 3.2 The connections have been demonstrated by cyclic tests to have adequate rotation capacity to accommodate a story drift due to  $3 (R_w/8)$  times the design seismic forces.
  - 3.3 The moment frame drift calculations shall include the contribution due to the rotation and distortion of the connection.

See Divisions VIII and IX for definitions of fully restrained and partially restrained connections.

**2211.7 Special Moment-resisting Frame (SMRF) Requirements.**

**2211.7.1 Girder-to-column connection.**

**2211.7.1.1 Required strength.** The girder-to-column connection shall be adequate to develop the lesser of the following:

1. The strength of the girder in flexure.
2. The moment corresponding to development of the panel zone shear strength as determined from Formula (11-1).

**EXCEPTION:** Where a connection is not designed to contribute flexural resistance at the joint, it need not develop the required strength if it can be shown to meet the deformation compatibility requirements of Section 1631.2.4.

**2211.7.1.2 Connection strength.** Connection configurations utilizing welds or high-strength bolts shall demonstrate, by approved cyclic test results or calculation, the ability to sustain inelastic rotation and develop the strength criteria in Section 2211.7.1.1 considering the effect of steel over-strength and strain hardening.

**2211.7.1.3 Flange detail limitations.** For steel whose specified ultimate strength is less than 1.5 times the specified yield strength, plastic hinges shall not form at locations in which the beam flange area has been reduced, such as for bolt holes. Bolted connections of flange plates of beam-column joints shall have the net-to-gross area ratio  $A_e/A_g$  equal to or greater than  $1.2 F_y/F_u$ .

### 2211.7.2 Panel zone.

**2211.7.2.1 Strength.** The panel zone of the joint shall be capable of resisting the shear induced by beam bending moments due to gravity loads plus 1.85 times the prescribed seismic forces, but the shear strength need not exceed that required to develop  $0.8 \sum M_s$  of the girders framing into the column flanges at the joint. The joint panel zone shear strength may be obtained from the following formula:

$$V = 0.55 F_y d_c t \left[ 1 + \frac{3 b_c t_{cf}^2}{d_b d_c t} \right] \quad (11-1)$$

#### WHERE:

$b_c$  = the width of the column flange.

$d_b$  = the depth of the beam.

$d_c$  = the column depth.

$t$  = the total thickness of the joint panel zone including doubler plates.

$t_{cf}$  = the thickness of the column flange.

**2211.7.2.2 Thickness.** The panel zone thickness,  $t_z$ , shall conform to the following formula:

$$t_z \geq (d_z + w_z)/90 \quad (11-2)$$

#### WHERE:

$d_z$  = the panel zone depth between continuity plates.

$w_z$  = the panel zone width between column flanges.

For this purpose,  $t_z$ , shall not include any double plate thickness unless the doubler plate is connected to the column web with plug welds adequate to prevent local buckling of the plate.

**2211.7.2.3 Doubler plates.** Doubler plates provided to reduce panel zone shear stress or to reduce the web depth thickness ratio shall be placed not more than  $1/16$  inch (1.6 mm) from the column web and shall be welded across the plate width top and bottom with at least a  $3/16$ -inch (4.7 mm) fillet weld. They shall be either butt or fillet welded to the column flanges to develop the shear strength of the doubler plate. Weld strength shall be as given in Section 2211.4.2.

**2211.7.3 Width-thickness ratio.** Girders shall comply with Division IX, except that the flange width-thickness ratio,  $b_f/2t_f$ , shall not exceed  $52/\sqrt{F_y}$  (For SI:  $0.31\sqrt{E/F_y}$ ). The width-thickness ratio of column sections shall meet the requirements of Division IX, Section 2251N7. The outside wall width-thickness ratio of rectangular tubes used for columns shall not exceed  $110/\sqrt{F_y}$  (For SI:  $0.65\sqrt{E/F_y}$ ), unless otherwise stiffened.

**2211.7.4 Continuity plates.** When determining the need for girder tension flange continuity plates, the value of  $P_{bf}$  in Division IX shall be taken as  $1.8(bt_f)F_{yb}$ .

**2211.7.5 Strength ratio.** At any moment frame joint, the following relationships shall be satisfied:

$$\Sigma Z_c (F_{yc} - f_a) / \Sigma Z_b F_{yb} > 1.0 \quad (11-3.1)$$

or

$$\Sigma Z_c (F_{yc} - f_a) / 1.25 \Sigma M_{pz} > 1.0 \quad (11-3.2)$$

**WHERE:**

$f_a > 0$

$M_{pz}$  = the sum of beam moments when panel zone shear strength reaches the value specified in Formula (11-1).

**EXCEPTION:** Columns meeting the compactness limitations for beams given in Section 2211.7.3 need not comply with this requirement provided they conform to one of the following conditions:

1. Columns with  $f_a$  less than  $0.4 F_y$  for all load combinations other than loads specified in Section 2211.5.1, and
  - 1.1 Which are used in the top story of a multistory building with building period greater than 0.7 second; or
  - 1.2 Where the sum of their resistance is less than 20 percent of the shear in a story, and is less than 33 percent of the shear on each of the column lines within that story. A column line is defined for the purpose of this exception as a single line of columns, or parallel lines of columns located within 10 percent of the plan dimension perpendicular to the line of columns; or
  - 1.3 When the design for combined axial compression and bending is proportioned to satisfy Division IX without the one-third permissible stress increase.
2. Columns in any story which have lateral shear strength 50 percent greater than that of the story above.
3. Columns which lateral shear strengths are not included in the design to resist code-required shears.

**2211.7.6 Trusses in SMRF.** Trusses may be used as horizontal members in SMRF if the sum of the truss seismic force flexural strength exceeds the sum of the column seismic force flexural strength immediately above and below the truss by a factor of at least 1.25. For this determination the strengths of the members shall be reduced by the gravity load effects. In buildings of more than one story, the column axial stress shall not exceed  $0.4F_y$  and the ratio of the unbraced column height to the least radius of gyration shall not exceed 60. Columns shall have allowable stresses reduced 25 percent when one end frames into a truss, and 50 percent when both ends frame into trusses. The connection of the truss chords to the column shall develop the lesser of the following:

1. The strength of the truss chord.
2. The chord force necessary to develop 125 percent of the flexural strength of the column.

**2211.7.7 Girder-column joint restraint.**

**2211.7.7.1 Restrained joint.** Where it can be shown that the columns of SMRF remain elastic, the flanges of the columns need be laterally supported only at the level of the girder top flange.

Columns may be assumed to remain elastic if one of the following conditions is satisfied:

1. The ratio in Formula (11-3.1) or (11-3.2) is greater than 1.25.
2. The flexural strength of the column is at least 1.25 times the moment that corresponds to the panel zone shear strength.
3. Girder flexural strength or panel zone strength will limit column stress ( $f_a + f_{bx} + f_{by}$ ) to  $F_y$  of the column.
4. The column will remain elastic under gravity loads plus  $3(R_w/8)$  times the prescribed seismic forces.

Where the column cannot be shown to remain elastic, the column flanges shall be laterally supported at the levels of the girder top and bottom flanges. The column flange lateral support shall be capable of resisting a force equal to one percent of the girder flange capacity at allowable stresses and at a limiting displacement perpendicular to the frame of 0.2 inch (5.1 mm). Required bracing members may brace the column flanges directly or indirectly through the column web or the girder flanges.

**2211.7.7.2 Unrestrained joint.** Columns without lateral support transverse to a joint shall conform to the requirements of Division IX, with the column considered as pin ended and the length taken as the distance between lateral supports conforming with Section 2211.7.7.1 above. The column stress,  $f_a$ , shall be determined from gravity loads plus the lesser of the following:

1.  $3(R_w/8)$  times the prescribed seismic forces.
2. The forces corresponding to either 125 percent of the girder flexural strength or the panel zone shear strength.

The stress,  $f_{by}$ , shall include the effects of the bracing force specified in Section 2211.7.7.1 and  $P\Delta$  effects.

$l/r$  for such columns shall not exceed 60.

At truss frames the column shall be braced at each truss chord for a lateral force equal to one percent of the compression yield strength of the chord.

**2211.7.8 Beam bracing.** Both flanges of beams shall be braced directly or indirectly. The beam bracing between column center lines shall not exceed  $96r_y$ . In addition, braces shall be placed at concentrated loads where a hinge may form.

**2211.7.9 Changes in beam flange area.** Abrupt changes in beam flange area are not permitted within possible plastic hinge regions of special moment-resistant frames.

**2211.7.10 Moment frame drift calculations.** Moment frame drift calculations shall include bending and shear contributions from the clear girder and column spans, column axial deformation and the rotation and distortion of the panel zone.

**EXCEPTIONS:** 1. Drift calculations may be based on column and girder center lines where either of the following conditions is met:

- 1.1 It can be demonstrated that the drift so computed for frames of similar configuration is typically within 15 percent of that determined above.
  - 1.2 The column panel zone strength can develop  $0.8\sum M_s$  of girders framing to the column flanges at the joint.
2. Column axial deformations may be neglected if they contribute less than 10 percent to the total drift.

### 2211.8 Requirements for Braced Frames.

**2211.8.1 General.** The provisions of this section apply to all braced frames except special concentrically braced frames designed in accordance with Section 2211.9 or eccentrically braced frames (EBF) designed in accordance with Section 2211.10. Those members which resist seismic forces totally or partially by shear or flexure shall be designed in accordance with Section 2211.7 except Section 2211.7.3.

**2211.8.2 Bracing members.**

**2211.8.2.1 Slenderness.** In Seismic Zones 3 and 4, the  $l/r$  ratio for bracing members shall not exceed  $720/\sqrt{F_y}$  (For SI:  $4.23\sqrt{E/F_y}$ ), except as permitted in Sections 2211.8.5 and 2211.8.6.

**2211.8.2.2 Stress reduction.** The allowable stress,  $F_{as}$ , for bracing members resisting seismic forces in compression shall be determined from the following formula:

$$F_{as} = BF_a \quad (11-4)$$

**WHERE:**

$B$  = the stress-reduction factor determined from the following formula:

$$B = 1/\{1 + [(Kl/r)/2C_d]\} \quad (11-5)$$

$F_a$  = the allowable axial compressive stress allowed in Division IX.

**EXCEPTION:** Bracing members carrying gravity loads may be designed using the column strength requirement and load combinations of Section 2211.5.1, Item 1.

**2211.8.2.3 Lateral-force distribution.** The seismic lateral force along any line of bracing shall be distributed to the various members so that neither the sum of the horizontal components of the forces in members acting in tension nor the sum of the horizontal components of forces in members acting in compression exceed 70 percent of the total force.

**EXCEPTION:** Where compression bracing acting alone has the strength, neglecting the stress-reduction factor  $B$ , to resist  $3(R_w/8)$  times the prescribed seismic force such distribution is not required.

A line of bracing is defined, for the purpose of this provision, as a single line or parallel lines within 10 percent of the dimension of the structure perpendicular to the line of bracing.

**2211.8.2.4 Built-up members.** The  $l/r$  of individual parts of built-up bracing members between stitches, when computed about a line perpendicular to the axis through the parts, shall not be greater than 75 percent of the  $l/r$  of the member as a whole.

**2211.8.2.5 Compression elements in braces.** The width-thickness ratio of stiffened and unstiffened compression elements used in braces shall be as shown in Division IX.

**2211.8.3 Bracing connection.**

**2211.8.3.1 Forces.** Bracing connections shall have the strength to resist the least of the following:

1. The strength of the bracing in axial tension,  $P_{st}$ .
2.  $3(R_w/8)$  times the force in the brace due to the prescribed seismic forces, in combination with gravity loads.
3. The maximum force that can be transferred to the brace by the system.

Bracing connections shall, as a minimum, satisfy the load combinations required by Section 1603.6 at allowable stress limits, with stress increases allowed by Section 1603.5. These combinations shall include the provisions for Sections 2211.8.2.2 and 2211.8.4.1

Beam-to-column connections for beams that are part of the bracing system shall have the capacity to transfer the force determined above. Where eccentricities in the frame geometry or connection load path exist, the affected members and connections shall have the strength to resist all secondary forces resulting from the eccentricities in combination with all primary forces using the lesser of the forces determined above.

**2211.8.3.2 Net area.** In bolted brace connections, the ratio of effective net section area to gross section area shall satisfy the formula:

$$\frac{A_e}{A_g} \geq \frac{1.2 \alpha F^*}{F_u} \quad (11-6)$$

**WHERE:**

$A_e$  = effective net area as defined in Division IX.

$F_u$  = minimum tensile strength.

$F^*$  = stress in brace as determined in Section 2211.8.3.1.

$\alpha$  = fraction of the member force from Section 2211.8.3.1 that is transferred across a particular net section.

**2211.8.4 Bracing configuration.****2211.8.4.1 Chevron bracing.** Chevron bracing shall conform with the following:

1. Bracing members shall be designed for 1.5 times the otherwise prescribed seismic forces, in addition to the requirements of Section 2211.8.2.2.
2. The beam intersected by chevron braces shall be continuous between columns.
3. Where chevron braces intersect a beam from below, i.e., inverted V brace, the beam shall be capable of supporting all tributary gravity loads presuming the bracing not to exist.

**EXCEPTION:** This limitation need not apply to penthouses, one-story buildings or the top story of buildings.

**2211.8.4.2 K bracing.** K bracing is prohibited except as permitted in Section 2211.8.5.**2211.8.4.3 Nonconcentric bracing.** Nonconcentric bracing shall conform with the following:

1. Any member intersected by the brace shall be continuous through the connection.
2. When the eccentricity of the brace is greater than the depth of the intersected member at the eccentric location, the affected member shall have the strength to resist the forces prescribed in Section 2211.8.3.1, including the effects of all secondary forces resulting from the eccentricities.

**2211.8.5 One- and two-story buildings.** Braced frames not meeting the requirements of Sections 2211.8.2 and 2211.8.4 may be used in buildings not over two stories in height and in roof structures as defined in Chapter 15 if the braces have the strength to resist  $3(R_w/8)$  times the code equivalent static forces.

**2211.8.6 Nonbuilding structures.** Nonbuilding structures with  $R_w$  values defined by Table 16-P need comply only with the provisions of Section 2211.8.3.

**2211.9 Requirements for Special Concentrically Braced Frames.**

**2211.9.1 General.** The provisions of this section apply to special concentrically braced frame structures as defined in Section 1625. All members and connections in special braced frames shall be designed and detailed to resist shear and flexure caused by eccentricities in the geometry of the members comprising the frame in accordance with Section 2211.9. Any member intersected by a brace shall be continuous through the connection. Horizontal bracing that transfers forces between horizontally offset bracing in the vertical plane shall be subject to the requirements of Section 2211.9, except Sections 2211.9.2.3; 2211.9.4.1, Item 3; and 2211.9.4.2. Horizontal bracing other than the above is not subjected to the requirements of Section 2211.9.

**2211.9.2 Bracing members.**

**2211.9.2.1 Slenderness.** The  $kl/r$  ratio for bracing members shall not exceed  $1,000/\sqrt{F_y}$  (For SI:  $5.87\sqrt{E/F_y}$ ), except as permitted in Section 2211.9.6.

**2211.9.2.2 Lateral-force distribution.** The seismic lateral force along any line of bracing shall be distributed to the various members so that neither the sum of the horizontal components of forces in members acting in compression or tension exceed 70 percent of the total force.

**EXCEPTION:** Where compression bracing acting alone has the strength to resist  $3(R_w/8)$  times the prescribed seismic force, such distribution is not required.

A line of bracing is defined, for the purposes of this provision, as a single line or parallel lines within 10 percent of the dimension of the structure perpendicular to the line of bracing.

**2211.9.2.3 Built-up members.** The spacing of stitches shall be such that the slenderness ratio ( $l/r$ ) of individual elements between the stitches does not exceed 0.4 times the governing slenderness ratio of the built-up member. The total shear strength of the stitches shall be at least equal to the tensile strength of each element. The spacing of the stitches shall be uniform and not less than two stitches shall be used. Bolted stitches shall not be located within the middle one fourth of the clear brace length.

**EXCEPTION:** Where it can be shown that braces can buckle without causing shear in the stitches, the spacing of the stitches shall be such that the slenderness ratio ( $l/r$ ) of the individual element between the stitches does not exceed 0.75 times the governing slenderness ratio of the built-up member.

**2211.9.2.4 Compression elements in braces.** The width-thickness ratio of compression elements used in braces shall meet the requirements of Division IX, Table B5.1, for compact sections. The width-thickness ratio of angle section shall be limited to  $52/\sqrt{F_y}$  (For SI:  $0.31\sqrt{E/F_y}$ ). Circular sections shall have outside diameter-wall thickness ratio not exceeding  $1,200/F_y$  (For SI:  $7.63 E/F_y$ ), rectangular tubes shall have outside wall width-thickness ratio not exceeding  $110/\sqrt{F_y}$  (For SI:  $0.65\sqrt{E/F_y}$ ).

**EXCEPTION:** Compression elements stiffened to resist local buckling.

### 2211.9.3 Bracing connections.

**2211.9.3.1 Forces.** Bracing connections shall have the strength to resist the lesser of the following:

1. The strength of the brace in axial tension,  $P_{st}$ .
2.  $3(R_w/8)$  times the force in the brace due to the prescribed seismic forces, in combination with gravity loads.
3. The maximum force that can be transferred to the brace by the system.

Bracing connections shall, as a minimum, satisfy the load combinations required by Section 1603.6 at allowable stress limits with stress increases allowed by Section 1603.5. Beam-to-column connections for beams that are part of the bracing system shall have the capacity to transfer the force determined above. Where eccentricities in the frame geometry or connection load path exist, the affected members and connections shall have the strength to resist all secondary forces resulting from the eccentricities in combination with all primary forces using the lesser of the forces determined above.

**2211.9.3.2 Net area.** In bolted brace connections, the ratio of effective net section area to gross section shall satisfy Formula (11-6) of Section 2211.8.3.2.

**2211.9.3.3 Gusset plates.** End connections of braces shall provide a flexural strength in excess of that of the brace gross section about the critical buckling axis.

**EXCEPTION:** Where the out-of-plane buckling strength of the brace is less than the in-plane buckling strength and the brace terminates on a single gusset plate connection with a setback of two times the gusset thickness from a line about which the gusset plate may bend unrestrained by the column or beam joints, and the gusset plate shall be designed to carry the compressive strength of the brace without buckling.

### 2211.9.4 Bracing configuration.

**2211.9.4.1 Chevron bracing.** Chevron bracing shall conform with the following:

1. The beam intersected by chevron braces shall be continuous between columns.
2. Where chevron braces intersect a beam from below, i.e., inverted V brace, the beam shall be capable of supporting all tributary gravity loads presuming the bracing not to exist.

3. A beam intersected by chevron braces shall have the strength to support the following tributary gravity loads and unbalanced brace force combinations:

$$\begin{aligned} 1.2D + 0.5L + P_b \\ 0.9D - P_b \end{aligned}$$

**WHERE:**

$D$  = tributary dead load.

$L$  = tributary live load.

$P_b$  = the maximum unbalanced post-buckling force that can be applied to the beam by the braces. For this purpose, the maximum unbalanced force may be computed using a minimum of  $P_{st}$  for the tension and a maximum of  $0.3 P_{sc}$  for the compression brace.

4. Both flanges of beams at the point of intersection of chevron braces shall be laterally supported directly or indirectly.

**EXCEPTION:** Limitations 2 and 3 need not apply to penthouses, one-story buildings or the top story of buildings.

**2211.9.4.2 K bracing.** K bracing is prohibited.

**2211.9.5 Columns.** Columns in braced frames shall meet the requirements of Section 2211.7.3. In addition to meeting the requirements of Sections 2211.5.1 and 2211.5.2, column splices shall be designed to develop the full shear strength and 50 percent of the full moment strength of the section. Splices shall be located in the middle one third of the column clear height.

**2211.9.6 Nonbuilding structures.** Nonbuilding structures with  $R_w$  values defined by Table 16-P need comply only with the provisions of Sections 2211.9.3.1 and 2211.9.3.2.

**2211.10 Eccentrically Braced Frame (EBF) Requirements.**

**2211.10.1 General.** Eccentrically braced frames shall be designed in accordance with this section.

**2211.10.2 Link beam.** There shall be a link beam provided at least at one end of each brace. Beams in EBFs shall comply with the requirements of Division IX, except that the flange width-thickness ratio,  $b_f/2t_f$ , shall not exceed  $52/\sqrt{F_y}$ . (For SI:  $0.31 \sqrt{E/F_y}$ .)

**2211.10.3 Link beam strength.** Link beam shear strength,  $V_s$ , and flexural strength,  $M_s$ , are the strengths as defined in Section 2211.4.2. Where link beam strength is governed by shear, the flexural and axial capacities within the link shall be calculated using the beam flanges only.

A reduced flexural strength,  $M_{rs}$ , for use in Sections 2211.10.8 and 2211.10.13 is defined as  $Z(F_y - f_a)$ . Where  $f_a$  is less than  $0.15F_y$ ,  $f_a$  may be neglected.

**2211.10.4 Link beam rotation.** The rotation of the link segment relative to the rest of the beam, at a total frame drift of  $3(R_w/8)$  times the drift determined for prescribed seismic forces, shall not exceed the following:

1. 0.060 radians for link segments having clear lengths of  $1.6 M_s/V_s$  or less.
2. 0.015 radians for link segments having clear lengths of  $3.0 M_s/V_s$  or greater.
3. A value obtained by linear interpolation for clear lengths between the above limits.

**2211.10.5 Link beam web.** The web of the link beam shall be single thickness without doubler plate reinforcement. No openings shall be placed in the web of a link beam. The web shear shall not exceed  $0.8V_s$  under prescribed lateral forces.

**2211.10.6 Beam connection braces.** Brace-to-beam connections shall develop the compression strength of the brace and transfer this force to the beam web. No part of the brace-to-beam connection shall extend into the web area of a link beam.

**2211.10.7 Link beam stiffeners.** Link beams shall have full-depth web stiffeners on both sides of the beam web at the brace end of the link beam. In addition, for link beams with clear lengths within the limits in Section 2211.10.4, Item 3, full-depth stiffeners shall be placed at a distance  $b_f$  from each end of the link. The stiffeners shall have a combined width not less than  $b - 2t_w$  and a thickness not less than  $0.75 t_w$  or less than  $3/8$  inch (9.5 mm).

**2211.10.8 Intermediate stiffeners.** Intermediate full-depth web stiffeners shall be provided in either of the following conditions:

1. Where the link beam strength is controlled by  $V_s$ .
2. Where the link beam strength is controlled by flexure and the shear determined by applying the reduced flexural strength,  $M_{rs}$ , exceeds  $0.45 F_y dt$ .

**2211.10.9 Web stiffener spacing.** Where intermediate web stiffeners are required, the spacing shall conform to the requirements given below.

1. For link beams with rotation angle of 0.06 radians, the spacing shall not exceed  $38t_w - d/5$ .
2. For link beams with a rotation angle of 0.03 radians or less, the spacing shall not exceed  $56t_w - d/5$ . Interpolation may be used for rotation angles between 0.03 and 0.06 radians.

**2211.10.10 Web stiffener location.** For beams 24 inches (610 mm) in depth and greater, intermediate full-depth web stiffeners are required on both sides of the web. Such web stiffeners are required only on one side of the beam web for beams less than 24 inches (610 mm) in depth. The stiffener thickness,  $t_w$ , of one side stiffeners shall not be less than  $3/8$  inch (9.5 mm) and the width shall not be less than  $(b_f/2) - t_w$ .

**2211.10.11 Stiffener welds.** Fillet welds connecting the stiffener to the beam web shall develop a stiffener force of  $A_{st} F_y$ . Fillet welds connecting the stiffener to the flanges shall develop a stiffener force of  $A_{st} F_y/4$ .

**WHERE:**

- $A_{st}$  =  $bt$  of stiffener.  
 $b$  = width of stiffener plate.

**2211.10.12 Link beam-column connections.** Length of link beam connected to columns shall not exceed  $1.6 M_s/V_s$ .

1. Where a link beam is connected to the column flange, the following requirements shall be met:

- 1.1 The beam flanges shall have full-penetration welds to the column.
- 1.2 Where the link beam strength is controlled by shear in conformance with Section 2211.10.8, the web connection shall be welded to develop the full link beam web shear strength.

2. Where the link beam is connected to the column web, the beam flanges shall have full-penetration welds to the connection plates and the web connection shall be welded to develop the link beam web shear strength. Rotation between the link beam and the column shall not exceed 0.015 radians at  $3(R_w/8)$  times the drift due to the prescribed seismic forces.

**2211.10.13 Brace and beam strengths.** The controlling link beam strength is either the shear strength,  $V_s$ , or the reduced flexural strength,  $M_{rs}$ , whichever results in the lesser axial force in the brace.

Each brace and beam outside the link shall have axial strength or reduced flexural strength,  $M_{rs}$ , at least 1.5 times the forces corresponding to the controlling link beam strength.

**2211.10.14 Column strength.** Columns shall be designed to remain elastic at 1.25 times the strength of the EBF bay, as defined in Section 2211.10.13 above. Column strength need not exceed the requirements of Section 2211.5.

**2211.10.15 Roof link beam.** A link beam is not required in roof beams for EBF over five stories.

**2211.10.16 Concentric brace in combination.** The first story of an EBF bay over five stories in height may be concentrically braced if this story can be shown to have an elastic capacity 50 percent greater than the yield capacity of the story frames above the first story.

**2211.10.17 Axial forces.** Axial forces in beams of EBF frames due to braces and due to transfer of seismic force to the end of the frames shall be included in the frame calculations.

**2211.10.18 Beam flanges.** Top and bottom flanges of EBF beams shall be laterally braced at the ends of link beams and at intervals not exceeding  $76/\sqrt{F_y}$  (For SI:  $0.45\sqrt{E/F_y}$ ) times the beam flange width. End bracing shall be designed to resist 6.0 percent of the beam flange strength, defined as  $F_y b_{ff}$ . Intermediate bracing shall be designed to resist 1.0 percent of the beam flange force at the brace point using the link beam strength determined in Section 2211.10.13.

**2211.10.19 Beam-column connection.** Beam connections to columns may be designed as pins in the plane of the beam web if the link beam is not adjacent to the column. Such connection shall have the capacity to resist a torsional moment of  $0.01F_y b_{ff} d$ .

**2211.11 Stud Wall Systems.** Stud wall systems may be used to resist the specified seismic forces in buildings not over five stories in height. Such systems shall comply with the following:

1. The  $l/r$  of the brace may exceed 200 and is unlimited.
2. All boundary members, chords and collectors shall be designed and detailed to transmit the induced axial forces.
3. Connection of the diagonal bracing member, top chord splices, boundary members and collectors shall be designed to develop the full tensile strength of the member or  $3(R_w/8)$  times the otherwise prescribed seismic forces.
4. Vertical and diagonal members of the braced bay shall be anchored so the bottom track is not required to resist uplift forces by bending of the track web.
5. Both flanges of studs in a bracing panel shall be braced to prevent lateral torsional buckling. Wire tied bridging shall not be considered to provide such restraint.
6. Screws shall not be used to resist lateral forces by pullout resistance.
7. Provision shall be made for pretensioning or other methods of installation of tension-only bracing to guard against loose diagonal straps.

## SECTION 2212 — STEEL STRUCTURES RESISTING FORCES INDUCED BY EARTHQUAKE MOTIONS IN SEISMIC ZONES 1 AND 2

**2212.1 General.** Design and construction of steel framing in lateral-force-resisting systems in Seismic Zones 1 and 2 shall conform to the requirements of this code. In addition, in Seismic Zone 2, such framing shall conform to the requirements of this section. Ordinary moment frames in Seismic Zone 1, meeting the requirements of Section 2212.4, may use an  $R_w$  value of 12. Other framing in Seismic Zone 1 need not comply with this section.

**2212.2 Definitions.** Definitions shall be as prescribed in Section 2211.2.

**2212.3 Materials.** Materials shall be as prescribed in Section 2211.4.

**EXCEPTION:** Ordinary moment frames in accordance with Section 2212.4.

**2212.4 Ordinary Moment Frame Requirements.** Ordinary moment frames (OMF) shall be designed to resist the load combinations in Section 1603.6. Ordinary moment frames in Seismic Zone 1 meeting these requirements may use an  $R_w$  value of 12.

All beam-to-column connections in OMFs which resist earthquake forces shall meet one of the following requirements:

1. Fully restrained (Type F.R. or Type 1) conforming with Section 2212.5.1.
2. Fully restrained (Type F.R. or Type 1) connections with the design strengths of the connections capable of resisting a combination of gravity loads and  $3(R_w/8)$  times the design seismic forces.
3. Partially restrained (Type P.R. or Type 3) connections are permitted provided:
  - 3.1 The connections are designed to resist the load combinations in Section 1603.6, and
  - 3.2 The connections have been demonstrated by cyclic tests to have adequate rotation capacity to accommodate a story drift due to  $3(R_w/8)$  times the design seismic forces.
  - 3.3 The moment frame drift calculations shall include the contribution due to the rotation and distortion of the connection.

See Divisions VIII and IX for definitions of fully restrained and partially restrained connections.

### 2212.5 Special Moment-resisting Frame (SMRF) Requirements.

#### 2212.5.1 Girder-to-column connection.

**2212.5.1.1 Required strength.** The girder-to-column connection shall be adequate to develop the lesser of the following:

1. The strength of the girder in flexure.
2. The moment corresponding to development of the panel zone shear strength as determined from Formula (11-1).

**EXCEPTION:** Where a connection is not designed to contribute flexural resistance at the joint, it need not develop the required strength if it can be shown to meet the deformation compatibility requirements of Section 1631.2.4.

**2212.5.1.2 Connection strength.** The girder-to-column connection may be considered to be adequate to develop the flexural strength of the girder if it conforms to the following:

1. The flanges have full-penetration butt welds to the columns.
2. The girder web-to-column connection shall be capable of resisting the girder shear determined for the combination of gravity loads and the seismic shear forces which result from compliance with Section 2212.5.1.1. This connection strength need not exceed that required to develop gravity loads plus  $3(R_w/8)$  times the girder shear resulting from the prescribed seismic forces.

Where the flexural strength of the girder flanges is greater than 70 percent of the flexural strength of the entire section [i.e.,  $b t_f (d - t_f) F_y > 0.7 Z_x F_y$ ] the web connection may be made by means of welding or high-strength bolting.

For girders not meeting the criteria in the paragraph above, the girder web-to-column connection shall be made by means of welding the web directly or through shear tabs to the column. That welding shall have a strength capable of development at least 20 percent of the flexural strength of the girder web. The girder shear shall be resisted by means of additional welds or friction-type high-strength bolts or both.

**2212.5.1.3 Alternate connection.** Connection configurations utilizing welds or high-strength bolts not conforming with Section 2212.5.1.2 may be used if they are shown by test or calculation to meet the criteria in Section 2212.5.1.1. Where conformance is shown by calculation, 125 percent of the strengths of the connecting elements may be used.

**2212.5.1.4 Flange detail limitations.** For steel whose specified strength is less than 1.5 times the specified yield strength, plastic hinges shall not form at locations in which the beam flange area has been reduced, such as for bolt holes. Bolted connections of flange plates of beam-column joints shall have the net-to-gross area ratio  $A_e/A_g$  equal to or greater than  $1.2F_y/F_u$ .

**2212.5.2 Trusses in SMRF.** Trusses may be used as horizontal members in SMRF if the sum of the truss seismic force flexural strength exceeds the sum of the column seismic force flexural

strength immediately above and below the truss by a factor of at least 1.25. For this determination, the strengths of the members shall be reduced by the gravity load effects. In buildings of more than one story, the column axial stress shall not exceed  $0.4F_y$  and the ratio of the unbraced column height to the least radius of gyration shall not exceed 60. The connection of the truss chords to the column shall develop the lesser of the following:

1. The strength of the truss chord.
2. The chord force necessary to develop 125 percent of the flexural strength of the column.

### 2212.5.3 Girder-column joint restraint.

**2212.5.3.1 Restrained joint.** Where it can be shown that the columns of SMRF remain elastic, the flanges of the columns need be laterally supported only at the level of the girder top flange.

Columns may be assumed to remain elastic if one of the following conditions is satisfied:

1. The ratio in Formula (11-3.1) or (11-3.2) is greater than 1.25.
2. The flexural strength of the column is at least 1.25 times the moment that corresponds to the panel zone shear strength.
3. Girder flexural strength or panel zone strength will limit column stress ( $f_a + f_{bx} + f_{by}$ ) to  $F_y$  of the column.
4. The column will remain elastic under gravity loads plus  $3(R_w/8)$  times the prescribed seismic forces.

Where the column cannot be shown to remain elastic, the column flanges shall be laterally supported at the levels of the girder top and bottom flanges. The column flange lateral support shall be capable of resisting a force equal to one percent of the girder flange capacity at allowable stresses [and at a limiting displacement perpendicular to the frame of 0.2 inch (5.08 mm)]. Required bracing members may brace the column flanges directly or indirectly through the column web or the girder flanges.

**2212.5.3.2 Unrestrained joint.** Columns without lateral support transverse to a joint shall conform to the requirements of Division IX, with the column considered as a pin ended and the length taken as the distance between lateral supports conforming with Section 2212.5.3.1. The column stress,  $F_a$ , shall be determined from gravity loads plus the lesser of the following:

1.  $3(R_w/8)$  times the prescribed seismic forces.
2. The forces corresponding to either 125 percent of the girder flexural strength or the panel zone shear strength.

The stress,  $f_{by}$ , shall include the effects of the bracing force specified in Section 2212.5.3.1 and  $P \Delta$  effects.

$l/r$  for such columns shall not exceed 60.

At truss frames, the column shall be braced at each truss chord for a lateral force equal to one percent of the compression yield strength of the chord.

**2212.5.4 Changes in beam flange area.** Abrupt changes in beam flange area are not permitted within possible plastic hinge regions of special moment-resistant frames.

### 2212.6 Requirements for Braced Frames.

**2212.6.1 General.** The provisions of this section apply to all braced frames, except special concentrically braced frames designed in accordance with Section 2211.9 and eccentrically braced frames designed in accordance with Section 2211.9. Those members which resist seismic forces totally or partially by shear or flexure shall be designed in accordance with Section 2212.5.

#### 2212.6.2 Bracing members.

**2212.6.2.1 Stress reduction.** The allowable stress,  $F_{as}$ , for bracing members resisting seismic forces in compression shall be determined from the following formula:

$$F_{as} = BF_a \quad (12-1)$$

**WHERE:**

$B$  = the stress-reduction factor determined from the following formula:

$$B = 1/[1 + [(Kl/r)/2C_c]] \geq 0.8 \quad (12-2)$$

$F_a$  = the allowable axial compressive stress allowed in Division IX.

**EXCEPTION:** Bracing members carrying gravity loads may be designed using the column strength requirement and load combinations of Section 2211.5.1, Item 1.

**2212.6.2.2 Built-up members.** The  $l/r$  of individual parts of built-up bracing members between stitches, when computed about a line perpendicular to the axis through the parts, shall not be greater than 75 percent of the  $l/r$  of the member as a whole.

**2212.6.2.3 Compression elements in braces.** The width-to-thickness ratio of stiffened and unstiffened compression elements used in braces shall be shown in Division IX.

**2212.6.3 Bracing connections.**

**2212.6.3.1 Forces.** Bracing connections shall be designed for the lesser of the following:

1. The tensile strength of the bracing.
2.  $3(R_w/8)$  times the force in the brace due to prescribed seismic forces.
3. The maximum force that can be transferred to the brace by the system.

Beam-to-column connections for beams that are part of the bracing system shall have the capacity to transfer the force determined above.

**2212.6.3.2 Net area.** In bolted brace connections, the ratio of effective net section area to gross section area shall satisfy the formula:

$$\frac{A_e}{A_g} = \frac{1.2\alpha F^*}{F_u} \quad (12-3)$$

**WHERE:**

$A_e$  = effective net area as defined in Division IX.

$A_g$  = gross area of the member.

$F_u$  = minimum tensile strength.

$F^*$  = stress in brace due to the forces determined in Section 2211.8.3.1.

$\alpha$  = fraction of the member force from Section 2211.8.3.1 that is transferred across a particular net section.

**2212.6.4 Bracing configuration for chevron and K bracing.** Bracing members shall be designed for 1.5 times the otherwise prescribed forces.

The beam intersected by chevron braces shall be continuous between columns.

Where chevron braces intersect a beam from below, i.e., inverted V brace, the beam shall be capable of supporting all tributary gravity loads presuming the bracing not to exist.

**EXCEPTION:** This limitation need not apply to penthouses, one-story buildings or the top story of buildings.

**2212.6.5 One- and two-story buildings.** Braced frames not meeting the requirements of Sections 2212.6.2 and 2212.6.4 may be used in buildings not over two stories in height and in roof structures as defined in Chapter 15 if the braces have the strength to resist  $3(R_w/8)$  times the code equivalent static forces.

**2212.6.6 Nonbuilding structures.** Nonbuilding structures with  $R_w$  values defined by Table 16-P, need comply only with the provisions of Section 2212.6.3.

**2212.7 Special Concentrically Braced Frames.** Special concentrically braced frames shall comply with the requirements of Section 2211.9.

**2212.8 Eccentrically Braced Frames.** Eccentrically braced frames shall comply with the requirements of Section 2211.10.

**2212.9 Nondestructive Testing.** Nondestructive testing shall comply with the provisions of Section 1703.

**Division II—DESIGN STANDARD FOR STRESS VARIATION OR  
STRESS REVERSAL DESIGN**

**Based on Specifications of the American Institute of Steel Construction, Inc.  
(November 1, 1978)**

**SECTION 2213 — SCOPE**

This division covers the design of structural steel members subject to repeated variation of stress.

**SECTION 2214 — DEFINITIONS**

For the purpose of this division, certain terms are defined as follows:

**FATIGUE** is the damage that may result in fracture after a sufficient number of fluctuations of stress.

**STRESS RANGE** is the magnitude of fatigue fluctuations.

**SECTION 2215 — STRESS RANGE COMPUTATION**

In the case of a stress reversal, stress range shall be computed as the numerical sum of maximum repeated tensile and compressive stresses or the sum of maximum shearing stresses of opposite direction at a given point resulting from differing arrangements of live load.

**SECTION 2216 — DESIGN FOR FATIGUE**

Members and their connections subject to fatigue loading shall be proportioned to satisfy the stress range limitations as provided in this standard.

In the design of members and connections subject to repeated variation of live load stress, consideration shall be given to the number of stress cycles, the expected range of stress and type and location of member or detail.

Loading conditions shall be classified as shown in Table 22-II-A.

The type and location of material shall be categorized as shown in Table 22-II-B.

The maximum stress shall not exceed the basic allowable stress provided in this code, and the maximum range of stress shall not exceed that given in Table 22-II-C.

**SECTION 2217 — PROVISIONS FOR MECHANICAL FASTENERS**

Range in stress in properly tightened A325 and A490 bolts need not be considered, but the maximum computed stress, including prying action, shall not exceed the values given in Division IX, subject to the following stipulations:

1. Connections subject to more than 20,000 cycles but not more than 500,000 cycles of direct tension may be designed for the stress produced by the sum of applied and prying loads if the prying load does not exceed 10 percent of the externally applied load. If the prying force exceeds 10 percent, the allowable tensile stress given in Division IX shall be reduced 40 percent, applicable to the external load alone.

2. Connections subject to more than 500,000 cycles of direct tension may be designed for the stress produced by the sum of applied and prying loads if the prying load does not exceed 5 percent of the externally applied load. If the prying force exceeds 5 percent, the allowable tensile stress given in Division IX shall be reduced 50 percent, applicable to the external load alone.

The use of other bolts and threaded parts subjected to tensile fatigue loading is not recommended.

Rivets, bolts and threaded parts subjected to cyclic loading in shear may be designed for the bearing-type shear stresses given in Division IX insofar as the fatigue strength of the fasteners themselves is concerned.

TABLE 22-II-A

LOADING CONDITION	NUMBER OF LOADING CYCLES:	
	From	To
1	20,000 <sup>1</sup>	100,000 <sup>2</sup>
2	100,000	500,000 <sup>3</sup>
3	500,000	2,000,000 <sup>4</sup>
4	Over 2,000,000	

<sup>1</sup>Approximately equivalent to two applications every day for 25 years.

<sup>2</sup>Approximately equivalent to 10 applications every day for 25 years.

<sup>3</sup>Approximately equivalent to 50 applications every day for 25 years.

<sup>4</sup>Approximately equivalent to 200 applications every day for 25 years.

TABLE 22-II-B

GENERAL CONDITION	SITUATION	KIND OF STRESS <sup>1</sup>	STRESS CATEGORY (See Table 22-II-C)
	× 25.4 for mm		
Plain material	Base metal with rolled or cleaned surfaces.	T or Rev.	A
Built-up members	Base metal and weld metal in members, without attachments, built up of plates or shapes connected by continuous full or partial-penetration groove welds and continuous fillet welds parallel to the direction of applied stress.	T or Rev.	B
	Calculated flexural stress, $f_b$ , at toe of welds on girder webs or flanges adjacent to welded transverse stiffeners.	T or Rev.	C
	Base metal at end of partial length welded cover plates having square or tapered ends, with or without welds across the ends.	T or Rev.	E
Mechanically fastened connections	Base metal at gross section of high-strength-bolted slip-resistant connections, except bearing-type connections subject to stress reversal and axially loaded joints which induce out-of-plane bending in connected material.	T or Rev.	B
	Base metal at net section of high-strength-bolted bearing-type connections	T or Rev.	B
	Base metal at net section of riveted and other mechanically fastened joints.	T or Rev.	B
Groove welds	Base metal and weld metal at full-penetration groove-welded splices of parts of similar cross section ground flush, with grinding in the direction of applied stress and with weld soundness established by radiographic or ultrasonic inspection.	T or Rev.	B
	Base metal and weld metal in or adjacent to full-penetration groove-welded splices at transitions in width or thickness, with welds ground to provide slopes no steeper than 1 to 2 <sup>1</sup> / <sub>2</sub> , with grinding in the direction of applied stress and with weld soundness established by radiographic or ultrasonic inspection.	T or Rev.	B
	Base metal and weld metal in or adjacent to full-penetration groove-welded splices, with or without transitions having slopes no greater than 1 to 2 <sup>1</sup> / <sub>2</sub> , when reinforcement is not removed and weld soundness is established by radiographic or ultrasonic inspection in accordance with the requirements of approved recognized standards.	T or Rev.	C

(Continued)

TABLE 22-II-B—(Continued)

GENERAL CONDITION	SITUATION	KIND OF STRESS <sup>1</sup>	STRESS CATEGORY (See Table 22-II-C)
	× 25.4 for mm		
Groove welds	Weld metal or partial-penetration transverse groove welds, based on effective throat area of the weld or welds.	T or Rev.	F
Attachments	Base metal at detail of any length attached by groove welds subject to transverse and/or longitudinal loading when the detail embodies a radiused transition with the weld termination ground smooth. $R \geq 24$ inches $24 \text{ inches} > R \geq 6 \text{ inches}$ $6 \text{ inches} > R \geq 2 \text{ inches}$	T or Rev. T or Rev. T or Rev.	B C D
	Base metal at detail of limited length attached by groove weld subject to longitudinal loading with detail length, $L$ , and with no transition or with transition radius less than 2 inches. $2 \text{ inches} < L \leq 12t$ or 4 inches $L > 12t$ or 4 inches where $t$ is plate thickness.	T or Rev. T or Rev.	D E
	Base metal adjacent to a detail of any length in the direction parallel to the stress attached by fillet weld or partial-penetration groove welds when the details embody a radiused transition $\geq 2$ inches with weld termination ground smooth. $R > 24$ inches $24 \text{ inches} > R \geq 6 \text{ inches}$ $6 \text{ inches} > R \geq 2 \text{ inches}$	T or Rev. T or Rev. T or Rev.	B C D
	Base metal adjacent to a detail of limited length, $L$ , in the direction parallel to the stress attached by fillet weld or partial-penetration groove weld with no transition or with transition radius less than 2 inches. $2 \text{ inches} < L \leq 12t$ or 4 inches $L > 12t$ or 4 inches	T or Rev. R or Rev.	D E
	Base metal at intermittent fillet welds	T or Rev.	E
Fillet-welded connections	Base metal at junction of axially loaded members with fillet-welded end connections. Welds shall be disposed about the axis of the member so as to balance weld stresses.	T or Rev.	E
	Continuous or intermittent longitudinal or transverse fillet welds.	S	F
Miscellaneous details	Base metal at plug or slot welds.	T or Rev.	E
	Shear stress on nominal area of stud-type shear connectors.	S	F
	Shear on plug or slot welds.	S	F
	Base metal at a stud-type shear connector attached by fillet weld.	T or Rev.	C

<sup>1</sup>“T” signifies range in tensile stress only; “Rev.” signifies a range involving reversal of tensile or compressive stress; “S” signifies range in shear including shear stress reversal.

TABLE 22-II-C

CATEGORY (from Table 22-II-B)	ALLOWABLE RANGE OF STRESS, $F_{sr}$ (ksi)			
	× 6.89 for MPa			
	Loading Condition 1 $F_{sr1}$	Loading Condition 2 $F_{sr2}$	Loading Condition 3 $F_{sr3}$	Loading Condition 4 $F_{sr4}$
A <sup>1</sup>	60	36	24	24
B	45	27.5	18	16
C	32	19	13	10 <sup>1</sup>
D	27	16	10	7
E	21	12.5	8	5
F	15	12	9	8

<sup>1</sup>Flexural stress range of 12 ksi is permitted at toe of stiffener welds on girder webs or flanges.

**Division III—DESIGN STANDARD FOR OPEN-WEB STEEL JOISTS****Based on Standard Specifications of the Steel Joist Institute for Open Web Steel Joists, K-Series; for Longspan Steel Joists, LH-Series and Deep Longspan Steel Joists, DLH-Series; and Joist Girders, 1985 (including 1991 revisions)**

This division, "*Standard Specifications for Open Web Steel Joists, K-Series; for Longspan Steel Joists, LH-Series and Deep Longspan Steel Joists, DLH-Series; and for Joist Girders*," is reproduced in its entirety with permission of the publisher.

**SECTION 2218 — AMENDMENTS**

The SJI Specifications adopted by this division apply to the design of Open Web Steel Joists, K-Series; Longspan Steel Joists, LH-Series and Deep Longspan Steel Joists, DLH-Series; and Joist Girders except as modified by this part. Where other codes, standards or specifications are referred to in this standard, they are to be considered as only an indication of an acceptable method or material that can be used with the approval of the building official.

**1. No Modifications****SECTION 2219 — ADOPTION**

Reproduced with permission from the Steel Joist Institute, 1205 48th Avenue, North, Suite A, Myrtle Beach, SC 29577. Persons desiring to reprint in whole or in part any portion of this specification must secure permission from the Steel Joist Institute.

**STANDARD SPECIFICATION FOR OPEN WEB STEEL JOISTS, K-SERIES**

Adopted by the Steel Joist Institute November 4, 1985  
Revised to November 12, 1991

**SECTION 1  
SCOPE**

These specifications cover the design, manufacture and use of Open Web Steel Joists, K Series.

**SECTION 2  
DEFINITION**

The term "Open Web Steel Joists K Series," as used herein, refers to open-web, parallel-chord, load-carrying members suitable for the direct support of floors and roof decks in buildings, utilizing hot-rolled or cold-formed steel, including cold-formed steel whose yield strength\* has been attained by cold working. K-Series Joists shall be designed in accordance with these specifications to support the uniformly distributed loads given in the Standard Load Tables for Open Web Steel Joists, K-Series, attached hereto.

The design of chord sections for K-Series joists shall be based on a yield strength of 50,000 psi (345 MPa). The design of web sections for K-Series joists shall be based on a yield strength of either 36,000 psi (250 MPa) or 50,000 psi (345 MPa). Steel used for K-Series joist chord or web sections shall have a minimum yield strength determined in accordance with one of the procedures specified in Section 3.2, which is equal to the yield strength assumed in the design.

\*The term "Yield Strength" as used herein shall designate the yield level of a material as determined by the applicable method outlined in paragraph 13—"Yield Strength," or paragraph 12 "Yield Point," of ASTM Standard A370, "Mechanical Testing of Steel Products," or as specified in Section 3.2 of this Specification.

Standard Specifications and Load Tables. Open Web Steel Joists, K-Series. Copyright 1992.  
Steel Joist Institute

### SECTION 3 MATERIALS

#### 3.1 STEEL

The steel used in the manufacture of chord and web sections shall conform to one of the following ASTM Specifications of latest adoption:

Structural Steel, ASTM A36/A36M.

High-Strength, Low-Alloy Structural Steel, ASTM A242/A242M.

High-Strength, Low Alloy Structural Manganese Vanadium Steel, ASTM A441.

Hot-Rolled Carbon Steel Sheet and Strip, Structural Quality, ASTM A570/A570M.

High-Strength, Low-Alloy Columbium-Vanadium Steels of Structural Quality, ASTM A572/A572M, Grade 50.

High-Strength, Low-Alloy Structural Steel with 50,000 psi (345 MPa) Minimum Yield Point to 4" (102 mm) thick, ASTM A588/A588M.

Steel Sheet and Strip, Hot-Rolled and Cold-Rolled, High-Strength Low-Alloy, with Improved Corrosion Resistance, ASTM A606.

Steel Sheet and Strip, Hot-Rolled and Cold Rolled, High-Strength, Low-Alloy, Columbium and/or Vanadium, ASTM A607, Grade 50.

Steel, Cold-Rolled Sheet, Carbon Structural ASTM A611, Grade D

or shall be of suitable quality ordered or produced to other than the listed specifications, provided that such material in the state used for final assembly and manufacture is weldable and is proved by tests performed by the producer or manufacturer to have the properties specified in Section 3.2.

#### 3.2 MECHANICAL PROPERTIES

The yield strength used as a basis for the design stresses prescribed in Section 4 shall be either 36,000 psi (250 MPa) or 50,000 psi (345 MPa). Evidence that the steel furnished meets or exceeds the design yield strength shall, if requested, be provided in the form of an affidavit or by witnessed or certified test reports.

For material used without consideration of increase in yield strength resulting from cold forming, the specimens shall be taken from as-rolled material. In the case of material, the mechanical properties of which conform to the requirements of one of the listed specifications, test specimens and procedures shall conform to those of such specifications and to ASTM A370. In the case of material, the mechanical properties of which do not conform to the requirements of one of the listed specifications, the test specimens and procedures shall conform to the applicable requirements of ASTM A370, and the specimens shall exhibit a yield strength equal to or exceeding the design yield strength and an elongation of not less than (a) 20 percent in 2 inches (51 mm) for sheet and strip, or (b) 18 percent in 8 inches (203 mm) for plates, shapes and bars with adjustments for thickness for plates, shapes and bars as prescribed in ASTM A36/A36M, A242/A242M, A441, A572/A572M and A588/A588M, whichever specification is applicable on the basis of design yield strength. The number of tests shall be as prescribed in ASTM A6 for plates, shapers, and bars; and ASTM A570/A570M, A606, A607, and A611 for sheet and strip.

If as-formed strength is utilized, the test reports shall show the results of tests performed on full-section specimens in accordance with the provisions of Section 3.1.1 and 6.3 of the AISI Specifications for the Design of Cold Formed Steel Structural Members and shall indicate compliance with these provisions and with the following additional requirements:

- (a) The yield strength measured in the tests shall equal or exceed the design yield strength.
- (b) Where tension tests are made for acceptance and control purposes, the tensile strength shall be at least 6 percent greater than the yield strength of the section.
- (c) Where compression tests are used for acceptance and control purposes, the specimen shall withstand a gross shortening of 2 percent of its original length without cracking. The length of the specimen shall not be greater than 20 times its least radius of gyration.
- (d) If any test specimen fails to pass the requirements of subparagraphs (a), (b), or (c) above, as applicable, two retests shall be made of specimens from the same lot. Failure of one of the retest specimens to meet such requirements shall be the cause for rejection of the lot represented by the specimens.

### 3.3 PAINT

The standard shop paint is a primer coat intended to protect the steel for only a short period of exposure in ordinary atmospheric conditions and shall be considered an impermanent and provisional coating.

The standard shop paint shall conform to one of the following:

- (a) Steel Structures Painting Council Specification 15-68T, Type I (red oxide).
- (b) Federal Specification TT-P-636 (red oxide).
- (c) Or, shall be a shop paint which meets the minimum performance requirements of one of the above listed specifications.

## SECTION 4 DESIGN AND MANUFACTURE

### 4.1 METHOD

Joists shall be designed in accordance with these specifications as simply supported, uniformly loaded trusses supporting a floor or roof deck so constructed as to brace the top chord of the joists against lateral buckling. Where any applicable design feature is not specifically covered herein, the design shall be in accordance with the following specifications of latest adoption:

- (a) American Institute of Steel Construction for Design, Fabrication and Erection of Structural Steel for Buildings, where the material used consists of plates, shapes or bars.
- (b) American Iron and Steel Institute Specification for the Design of Cold-Formed Steel Structural Members, for members which are formed from sheet or strip material.

### 4.2 UNIT STRESSES

Joists shall have their components so proportioned that the unit stresses in pounds per square inch (MPa) shall not exceed the following where  $F_y$  is the yield strength defined in Section 3.2.

(a) **Tension:**

**Chords**

$$F_y = 50,000 \text{ psi (345 MPa)}$$

$$F_t = 30,000 \text{ psi (207 MPa)}$$

**Webs**

$$F_y = 50,000 \text{ psi (345 MPa)}$$

$$F_t = 30,000 \text{ psi (207 MPa)}$$

$$F_y = 36,000 \text{ psi (250 MPa)}$$

$$F_t = 22,000 \text{ psi (152 MPa)}$$

**(b) Compression:**

For members with  $l/r$  less than  $C_c$ :

$$F_a = \frac{\left[1 - \frac{(l/r)^2}{2C_c^2}\right] QF_y}{\frac{5}{3} + \frac{3}{8} \left(\frac{l/r}{C_c}\right) - \frac{1}{8} \left(\frac{l/r}{C_c}\right)^3} \text{ where } C_c = \sqrt{\frac{2\pi^2 E}{QF_y}} \text{ and}$$

where  $Q$  is a form factor equal to unity except when the width-thickness ratio of one or more elements of the profile exceeds the limits specified in the AISC Specifications, Section B5 (Allowable Stress Design) for hot-rolled sections and in the AISI Specifications, Section 3, for cold-formed sections.

For members with  $l/r$  greater than  $C_c$ :

$$F_a = \frac{12\pi^2 E}{23 (l/r)^2}$$

In the above formulas,  $l$  is taken as the distance between panel points for the chord members and the unbraced length clear of attachments for web members, and  $r$  is the corresponding least radius of gyration of the member or any component thereof.  $E$  is equal to 29,000,000 psi (200 000 MPa).

**(c) Bending:**

**For chords**

$F_y = 50,000 \text{ psi (345 MPa)}$

$F_b = 30,000 \text{ psi (207 MPa)}$

**For web members other than solid rounds**

$F_y = 50,000 \text{ psi (345 MPa)}$

$F_b = 30,000 \text{ psi (207 MPa)}$

$F_y = 36,000 \text{ psi (250 MPa)}$

$F_b = 22,000 \text{ psi (151 MPa)}$

**For web members of solid round cross section**

$F_y = 50,000 \text{ psi (345 MPa)}$

$F_b = 45,000 \text{ psi (310 MPa)}$

$F_y = 36,000 \text{ psi (250 MPa)}$

$F_b = 32,500 \text{ psi (224 MPa)}$

**For bearing plates**

$F_y = 50,000 \text{ psi (345 MPa)}$

$F_b = 37,500 \text{ psi (258 MPa)}$

$F_y = 36,000 \text{ psi (250 MPa)}$

$F_b = 27,000 \text{ psi (186 MPa)}$

**4.3 MAXIMUM SLENDERNESS RATIOS**

The slenderness ratio,  $l/r$ , where  $l$  is as used in Section 4.2 (b) and  $r$  is the corresponding least radius of gyration, shall not exceed the following:

Top chord interior panels .....	90
Top chord end panels .....	120
Compression members other than top chord .....	200
Tension members .....	240

**4.4 MEMBERS****(a) Chords**

The bottom chord shall be designed as an axially loaded tension member.

The top chord shall be designed for only axial compressive stress when the panel length,  $l$ , does not exceed 24 inches (609 mm). When the panel length exceeds 24 inches (609 mm), the top chord shall be designed as a continuous member subject to combined axial and bending stresses and shall be so proportioned that:

$$f_a + f_b \leq 0.6F_y, \text{ at the panel point; and}$$

$$\frac{f_a}{F_a} + \frac{C_m f_b}{\left(1 - \frac{f_a}{F'_c}\right) Q F_b} \leq 1.0 \text{ at mid-panel; in which}$$

$C_m = 1 - 0.4 f_a/F'_c$  for interior panels

$f_a =$  Computed axial unit compressive stress

$f_b =$  Computed bending unit compressive stress at the point under consideration

$F_a =$  Permissible axial unit compressive stress based on  $l/r$  as defined in Section 4.2 (b).

$F_b =$  Permissible bending unit stress

$F_y =$  Specified minimum yield strength

$$F'_c = \frac{12\pi^2 E}{23(l/r_x)^2}$$

where  $l$  is the panel length as defined in Section 4.2 (b) and  $r_x$  is the radius of gyration about the axis of bending

$Q =$  Form factor as defined in Section 4.2 (b).

In order to insure lateral stability during erection, the radius of gyration of the top chord about its vertical axis shall not be less than  $l/145$  where  $l$  is the spacing in inches between lines of bridging as specified in Section 5.4 (c).

The top chord shall be considered as stayed laterally by the floor slab or roof deck when attachments are in accordance with the requirements of Section 5.8 (e) of these specifications.

**(b) Web**

The vertical shears to be used in the design of the web members shall be determined from full uniform loading, but such vertical shears shall not be less than 25 percent of the end reaction. Due consideration shall be given to the effect of eccentricity. The effect of combined axial compression and bending may be investigated using the provisions of Section 4.4 (a), letting  $C_m = 0.4$  when bending due to eccentricity produces reversed curvature.

Interior vertical web members used in modified Warren-type web systems shall be designed to resist the gravity loads supported by the members plus one half of 1.0 percent of the top chord axial force.

**(c) Extended Ends**

Extended top chords or full-depth cantilever ends require the special attention of the specifying professional.

The magnitude and location of the design loads to be supported, the deflection requirements and the proper bracing shall be clearly indicated on the structural drawings.

## 4.5 CONNECTIONS

### (a) Methods

Joint connections and splices shall be made by attaching the members to one another by arc or resistance welding or by another approved method.

#### 1) Welded connections.

a) Selected welds shall be inspected visually by the manufacturer. Prior to this inspection, weld slag shall be removed.

b) Cracks are not acceptable and shall be repaired.

c) Thorough fusion shall exist between weld and base metal for the required design length of the weld; such fusion shall be verified by visual inspection.

d) Unfilled weld craters shall not be included in the design length of the weld.

e) Undercut shall not exceed  $1/16$  inch (2 mm) for welds oriented parallel to the principle stress.

f) The sum of surface (piping) porosity diameters shall not exceed  $1/16$  inch (2 mm) in any 1 inch (26 mm) of design weld length.

g) Weld spatter that does not interfere with paint coverage is acceptable.

#### 2) Welding Program.

Manufacturers shall have a program for establishing weld procedures and operator qualification, and for weld sampling and testing. (See Technical Digest # 8—Welding of Open Web Steel Joists).

#### 3) Weld Inspection by Outside Agencies.

(See Section 5.12 of these specifications) The agency shall arrange for visual inspection to determine that welds meet the acceptance standards of Section 4.5 (a) 1) above. Ultrasonic, X-Ray, and magnetic particle testing are inappropriate for joists due to the configurations of the components and welds.

### (b) Strength

Joint connections shall be capable of withstanding forces due to an ultimate load equal to at least two times the design load shown in the applicable Standard Load Table.

### (c) Splices

Splices may occur at any point in chord or web members. Members containing a butt weld splice shall develop an ultimate tensile force of at least 57,000 psi (393 MPa) times the full design area of the chord or web. The term "member" shall be defined as all component parts comprising the chord or web, at the point of splice.

### (d) Eccentricity

Members connected at a joint shall have their centroidal axes meet at a point if practical. Otherwise, due consideration shall be given to the effect of eccentricity. In no case shall eccentricity of any web member at a joint exceed three fourths of the overall dimension, measured in the plane of the web of the largest member connected. The eccentricity of any web member shall be the perpendicular distance from the centroidal axis of that web member to the point on the centroidal axis of the chord which is vertically above or below the intersection of the centroidal axes of the web members forming the joint. Ends of joists shall be proportioned to resist bending produced by eccentricity at the support.

## 4.6 VERIFICATION OF DESIGN AND MANUFACTURE

### (a) Design Calculations

Companies manufacturing K- Series Joists shall submit design data to the Steel Joist Institute (or an independent agency approved by the Steel Joists Institute) for verification of compliance with

the SJI Specifications. Design Data shall be submitted in detail and in the format specified by the Institute.

**(b) Test of Chord and Web Members**

Each manufacturer shall, at the time of design review by the Steel Joist Institute or other independent agency, verify by tests that his design, in accordance with Section 4.1 through 4.5 of this specification, will provide a minimum factor of safety of 1.65 on the theoretical design capacity of critical members. Such tests shall be evaluated considering the actual yield strength of the members of the test joists.

Material tests for determining mechanical properties of component members shall be conducted on full sections.

**(c) Tests of Joints and Connections**

Each manufacturer shall verify by shear tests on representative joints of typical joists that connections will meet the provision of Section 4.5 (b). Chord and web members may be reinforced for such tests.

**(d) In-Plant Inspections**

Each manufacturer shall verify his ability to manufacture K-Series Joists through periodic In-Plant Inspections. Inspections shall be performed by an independent agency approved by the Steel Joist Institute. The frequency, manner of inspection, and manner of reporting shall be determined by the Steel Joist Institute. The plant inspections are not a guarantee of the quality of any specific joists or Joist Girders; this responsibility lies fully and solely with the individual manufacturer.

**4.7 CAMBER**

Camber is optional with the manufacturer but, when provided, recommended approximate camber is as follows:

<b>Top Chord Length</b>	<b>Approximate Camber</b>
20 feet (6096 mm)	$\frac{1}{4}$ inch (7 mm)
30 feet (9144 mm)	$\frac{3}{8}$ inch (10 mm)
40 feet (12 192 mm)	$\frac{5}{8}$ inch (16 mm)
50 feet (15 240 mm)	1 inch (26 mm)
60 feet (18 288 mm)	1 $\frac{1}{2}$ inches (38 mm)

In no case will joists be manufactured with negative camber.

**4.8 SHOP PAINT**

Joists and accessories shall receive one shop coat of paint as specified in Section 3.3.

**SECTION 5  
APPLICATION**

**5.1 USAGE**

These specifications shall apply to any type of structure where floors and roofs are to be supported directly by steel joists installed as hereinafter specified. Where joists are used other than on simple spans under uniformly distributed loading as prescribed in Section 4.1, they shall be investigated and modified if necessary to limit the unit stresses to those listed in Section 4.2.

**CAUTION:** If a rigid connection of the bottom chord is to be made to the column or other support, it shall be made only after the application of the dead loads. The joist is then no longer simply

supported, and the system must be investigated for continuous frame action by the specifying professional.

## 5.2 SPAN

The span of a joist shall not exceed 24 times its depth.

## 5.3 END SUPPORTS

### (a) Masonry and Concrete

K-Series joists supported by masonry or concrete are to bear on steel bearing plates and shall be designed as steel bearing. Due consideration of the end reactions and all other vertical or lateral forces shall be taken by the specifying professional in the design of the steel bearing plate and the masonry or concrete. The ends of K-Series joists shall extend a distance of not less than 4 inches (102 mm) over the masonry or concrete support and be anchored to the steel bearing plate. The plate shall be located not more than  $1/2$ -inch (13 mm) from the face of the wall and shall not be 6 inches (153 mm) wide perpendicular to the length of the joist. It is to be designed by the specifying professional in compliance with the allowable unit stresses in Section A51, (Allowable Stress Design) of the A.I.S.C. Specifications of latest adoption. The steel bearing plate shall be furnished by other than the joist manufacturer.

Where it is deemed necessary to bear less than 4 inches (102 mm) over the masonry or concrete support, special consideration is to be given to the design of the steel bearing plate and the masonry or concrete by the specifying professional. The joists must bear a minimum of  $2\frac{1}{2}$  inches (64 mm) on the steel bearing plate.

### (b) Steel

Due consideration of the end reactions on all other vertical and lateral forces shall be taken by the specifying professional in the design of the steel support. The ends of K-Series joists shall extend a distance of not less than  $2\frac{1}{2}$  inches (64 mm) over the steel supports.

## 5.4 BRIDGING

Bridging is required and shall consist of one of the following types.

### (a) Horizontal

Horizontal bridging shall consist of two continuous horizontal steel members, one attached to the top chord and the other attached to the bottom chord. Each attachment to the joists shall be made by welding or mechanical means and shall be capable of resisting a horizontal force of not less than 700 pounds (3114 N).

The ratio of unbraced length to least radius of gyration ( $l/r$ ) of the bridging member shall not exceed 300, where  $l$  is the distance in inches (mm) between attachments and  $r$  is the least radius of gyration of the bridging member. If the bridging member is a round bar, the diameter shall be at least  $1/2$  inch (13 mm).

### (b) Diagonal

Diagonal bridging shall consist of cross bracing with  $l/r$  ratio of not more than 200, where  $l$  is the distance in inches (mm) between connections and  $r$  is the least radius of gyration of the bracing member. Where cross-bracing members are connected at their point of intersection, the  $l$  distance shall be taken as the distance in inches (mm) between connections at the point of intersection of the bracing members and the connections to the chord of the joists. Connections to the chords of steel joists shall be made by positive mechanical means or by welding.

**Number Of Rows Of Bridging\*\*\***  
**Distances are Span Lengths**  
**(See "Definition of Span" in front of load table)**

*Section Number	1 Row	2 Rows	3 Rows	4 Rows**	5 Rows**
	Multiply table span lengths × 304.8 for mm				
#1	Up thru 16'	Over 16' thru 24'	Over 24' thru 28'		
#2	Up thru 17'	Over 17' thru 25'	Over 25' thru 32'		
#3	Up thru 18'	Over 18' thru 28'	Over 28' thru 38'	Over 38' thru 40'	
#4	Up thru 19'	Over 19' thru 28'	Over 28' thru 38'	Over 38' thru 48'	
#5	Up thru 19'	Over 19' thru 29'	Over 29' thru 39'	Over 39' thru 50'	Over 50' thru 52'
#6	Up thru 19'	Over 19' thru 29'	Over 29' thru 39'	Over 39' thru 51'	Over 51' thru 56'
#7	Up thru 20'	Over 20' thru 33'	Over 33' thru 45'	Over 45' thru 58'	Over 58' thru 60'
#8	Up thru 20'	Over 20' thru 33'	Over 33' thru 45'	Over 45' thru 58'	Over 58' thru 60'
#9	Up thru 20'	Over 20' thru 33'	Over 33' thru 46'	Over 46' thru 59'	Over 59' thru 60'
#10	Up thru 20'	Over 20' thru 37'	Over 37' thru 51'	Over 51' thru 60'	
#11	Up thru 20'	Over 20' thru 38'	Over 38' thru 53'	Over 53' thru 60'	
#12	Up thru 20'	Over 20' thru 39'	Over 39' thru 53'	Over 53' thru 60'	

\*Last digit(s) of joist designation shown in Load Tables.

\*\*Where 4 or 5 rows of bridging are required, a row nearest the mid-span of the joist shall be diagonal bridging with bolted connections at chords and intersection.

\*\*\*See Section 5.11 for additional bridging required for uplift design.

#### (c) Quantity

In no case shall the number of rows of bridging be less than that shown in the bridging table.

Spaces between rows shall be approximately uniform. See Section 5.11 for bridging required for uplift forces.

#### (d) Bottom Chord Bearing Joists

Where bottom chord bearing joists are utilized, there shall be a row of diagonal bridging near the support to provide lateral stability. This bridging shall be installed as the joists are set in place.

### 5.5 INSTALLATION OF BRIDGING

All bridging and bridging anchors shall be completely installed before construction loads are placed on the joists.

Bridging shall support the top chords against lateral movement during the construction period and shall hold the steel joists in the approximate position as shown on the plans.

The ends of all bridging lines terminating at walls or beams shall be anchored thereto.

### 5.6 END ANCHORAGE

#### (a) Masonry and Concrete

Ends of K-Series joists resting on steel bearing plates on masonry or structural concrete shall be attached thereto with a minimum of two  $\frac{1}{8}$ -inch (3 mm) fillet welds 1 inch (26 mm) long, or with a  $\frac{1}{2}$ -inch (13 mm) bolt.

#### (b) Steel

Ends of K-Series joists resting on steel supports shall be attached thereto with a minimum of two  $\frac{1}{8}$ -inch (3 mm) fillet welds 1 inch (26 mm) long, or with a  $\frac{1}{2}$ -inch (13 mm) bolt. In steel frames, where columns are not framed in at least two directions with structural steel members, joists at column lines shall be field bolted at the columns to provide lateral stability during construction.

(c) **Uplift**

Where uplift forces are a design consideration, roof joists shall be anchored to resist such forces.

**5.7 JOIST SPACING**

Joists shall be spaced so that the loading on each joist does not exceed the allowable load for the particular joist designation.

**5.8 FLOOR AND ROOF DECKS**

(a) **Material**

Floors and roof decks may consist of cast-in-place or precast concrete or gypsum, formed steel, wood or other suitable material capable of supporting the required load at the specified joist spacing.

(b) **Thickness**

Cast-in-place slabs shall not be less than 2 inches (51 mm) thick.

(c) **Centering**

Centering for cast-in-place slabs may be ribbed metal lath, corrugated steel sheets, paperbacked welded wire fabric, removable centering or any other suitable material capable of supporting the slab at the designated joist spacing. Centering shall not cause lateral displacement or damage to the top chord of joists during installation or removal of the centering or placing of the concrete.

(d) **Bearing**

Slabs or decks shall bear uniformly along the top chords of the joists.

(e) **Attachments**

Each attachment for slab or deck to top chords of joists shall be capable of resisting a lateral force of not less than 300 pounds (1335 N). The spacing shall not exceed 36 inches (914 mm) along the top chord.

(f) **Wood nailers**

Where wood nailers are used, such nailers in conjunction with deck or slab shall be attached to the top chords of the joists in conformance with Section 5.8 (e).

**5.9 DEFLECTION**

The deflection due to the design live load shall not exceed the following:

<b>Floors:</b>	$\frac{1}{360}$ span.
<b>Roofs:</b>	$\frac{1}{360}$ of span where a plaster ceiling is attached or suspended. $\frac{1}{240}$ of span for all other cases.

The Specifying Professional shall give due consideration to the effects of deflection in selection of joists.

**5.10 PONDING**

Unless a roof surface is provided with sufficient slope toward points of free drainage or adequate individual drains to prevent the accumulation of rainwater, the roof system shall be investigated to assure stability under ponding conditions in accordance with Section K2 of the AISC Specifica-

tions (Allowable Stress Design) of latest adoption.\*

The ponding investigation shall be performed by the specifying professional.

### 5.11 UPLIFT

Where uplift forces due to wind are a design requirement, these forces must be indicated on the contract drawings in terms of net uplift in pounds per square foot (Pa). When these forces are specified, they must be considered in the design of joists and/or bridging. A single line of **bottom chord** bridging must be provided near the first bottom chord panel points whenever uplift due to wind forces is a design consideration.\*\*

### 5.12 INSPECTION

Joists shall be inspected by the manufacturer before shipment to ensure compliance of materials and workmanship with the requirements of these specifications. If the purchaser wishes an inspection of the steel joists by someone other than the manufacturer's own inspectors, he may reserve the right to do so in his "Invitation to Bid" or the accompanying "Job Specifications."

Arrangements shall be made with the manufacturer for such inspection of the joists at the manufacturing shop by the purchaser's inspectors at purchaser's expense.

## SECTION 6\*\*\* HANDLING AND ERECTION

Care shall be exercised at all times to avoid damage to the joists and accessories through careless handling during unloading, storing and erecting.

**\*\*IMPORTANT\*\* UNDER NO CIRCUMSTANCES SHALL ANY PERSONNEL ATTEMPT TO WALK ON UNBRIDGED JOISTS. AS SOON AS THE JOISTS ARE ERECTED, ALL BRIDGING SHALL BE COMPLETELY INSTALLED AND ANCHORED, THEN THE JOISTS PERMANENTLY FASTENED INTO PLACE. UNTIL THIS IS DONE, NO CONSTRUCTION LOADS SHALL BE APPLIED TO THE JOISTS.**

Where bolted diagonal bridging is required per Section 5.4 (c), the hoisting cables shall not be released until the diagonal bridging is completely installed. In the case of bottom chord bearing joists, the ends of the joists must be restrained laterally per Section 5.4 (d), before the hoisting cables are released. Each joist shall be straightened and plumbed prior to connecting the bridging to the joist. When it is necessary for the erector to climb on the joists to install the bridging, extreme caution must be exercised since unbridged joists may exhibit some degree of instability under the erector's weight.

After the bridging is completely installed and anchored, the ends of the joists shall be fully connected to the support in accordance with Section 5.6. All field welding shall be performed in a workmanlike manner to insure that the joists are not damaged by such welding.

On cold-formed members whose yield strength has been attained by cold working, and whose as-formed strength is used in the design, the total length of weld at any one point shall not exceed 50 percent of the overall developed width of the cold-formed section.

During the construction period, the contractor shall provide means for adequate distribution of concentrated loads so that the carrying capacity of any joist is not exceeded.

---

\*For further reference, refer to Steel Joist Institute Technical Digest #3, "Structural Design of Steel Joist Roofs to Resist Ponding Loads."

\*\*For further reference, refer to Steel Joist Institute Technical Digest # 6, "Structural Design of Steel Joist Roofs to Resist Uplift Loads."

\*\*\*For thorough coverage of this topic, refer to SJI Technical Digest #9, "Handling and Erection of Steel Joists and Joist Girders".

OPEN WEB STEEL JOISTS, K SERIES

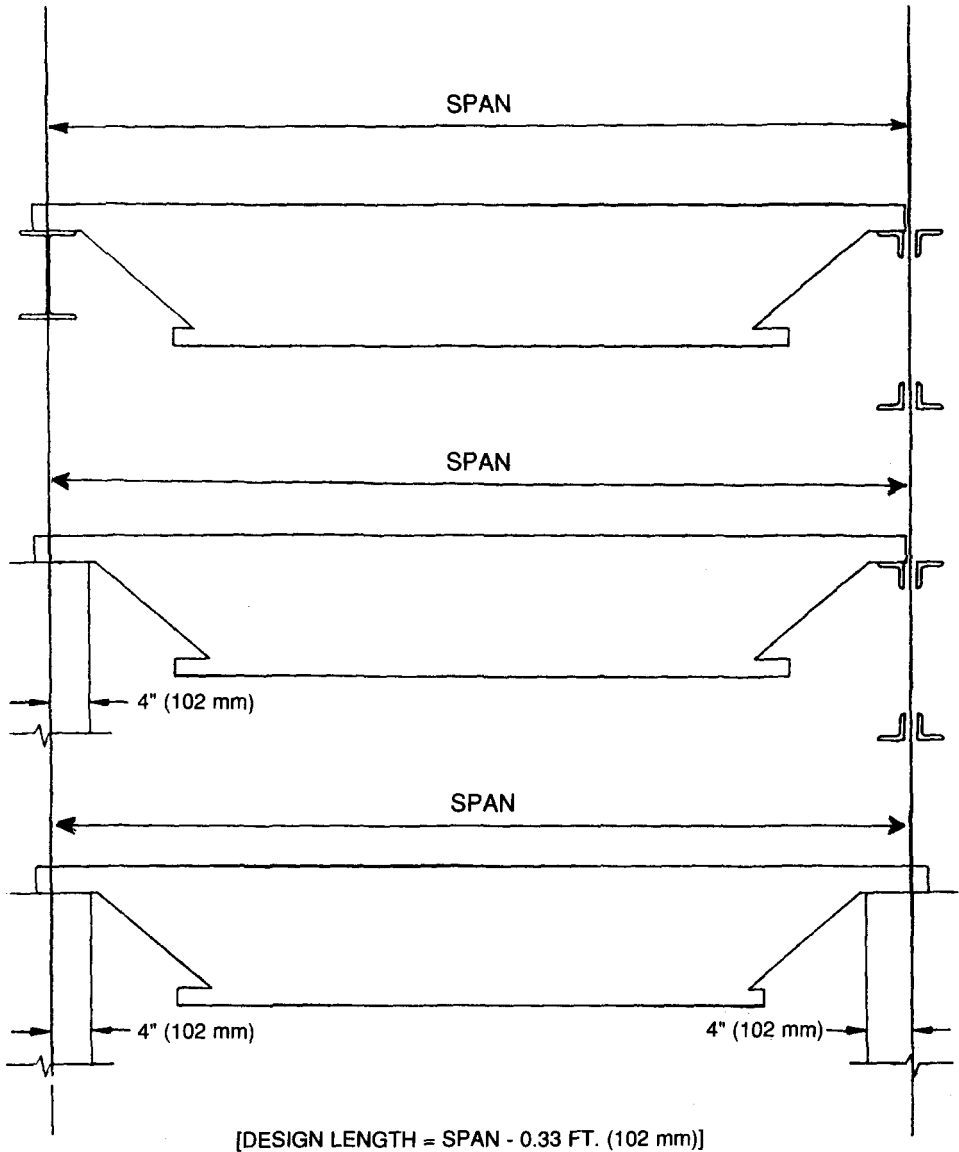

**DEFINITION OF SPAN**

**STANDARD LOAD TABLE—OPEN WEB STEEL JOISTS, K-SERIES**  
**Based on a Maximum Allowable Tensile Stress of 30,000 psi (207 MPa)**  
**Adopted by the Steel Joist Institute, November 4, 1985; Revised to May 19, 1987.**

The upper figures in the following table give the **total** safe uniformly distributed load-carrying capacities, in pounds per linear foot (x 14.59 for N/m), of K-Series Steel Joists. The weight of **dead** loads, including the joists, must be deducted to determine the **live** load-carrying capacities of the joists. The load table may be used for parallel chord joists installed to a maximum slope of 1/2 inch per foot (1:24).

The lower figures in this load table are the **live** loads per linear foot (x 14.59 for N/m) of joist which will produce an approximate deflection of 1/360 of the span. **Live** loads which will produce a deflection of 1/240 of the span may be obtained by multiplying the lower figures by 1.5. In no case shall the **total** load capacity of the joists be exceeded.

The approximate joist weights per linear foot shown in these tables do **not** include accessories.

The approximate moment of inertia of the joist, in inches<sup>4</sup> (mm<sup>4</sup>) is:  $I_j = 26.767 (W_{LL}) (L^3) (10^{-6})$  [ $I_j = 2.69 (W_{LL}) (L^3) (10^{-8})$ ], where  $W_{LL}$  = lower figure in the Load Table; L = (Span - 0.33), in feet (mm).

For the proper handling of concentrated and/or varying loads, see Section 5.5 in the Recommended Code of Standard Practice (page 65).

JOIST DESIGNATION	8K1	10K1	12K1	12K3	12K5	14K1	14K3	14K4	14K6	16K2	16K3	16K4	16K5	16K6	16K7	16K9
Depth (in.) × 25.4 for mm	8	10	12	12	12	14	14	14	14	16	16	16	16	16	16	16
Approx. Wt. (lbs./ft.) × 14.59 for N/m	5.1	5.0	5.0	5.7	7.1	5.2	6.0	6.7	7.7	5.5	6.3	7.0	7.5	8.1	8.6	10.0
*Span (ft.) × 304.8 for mm ↓																
8	550 550															
9	550 550															
10	550 480	550 550														
11	532 377	550 542														
12	444 288	550 455	550 550	550 550	550 550											
13	377 225	479 363	550 510	550 510	550 510											
14	324 179	412 289	500 425	550 463	550 463	550 550	550 550	550 550	550 550							
15	281 145	358 234	434 344	543 428	550 434	511 475	550 507	550 507	550 507							

(Continued)

## STANDARD LOAD TABLE—OPEN WEB STEEL JOISTS, K-SERIES—(Continued)

JOIST DESIGNATION	8K1	10K1	12K1	12K3	12K5	14K1	14K3	14K4	14K6	16K2	16K3	16K4	16K5	16K6	16K7	16K9
Depth (in.) × 25.4 for mm	8	10	12	12	12	14	14	14	14	16	16	16	16	16	16	16
Approx. Wt. (lbs./ft.) × 14.59 for N/m	5.1	5.0	5.0	5.7	7.1	5.2	6.0	6.7	7.7	5.5	6.3	7.0	7.5	8.1	8.6	10.0
*Span (ft.) × 304.8 for mm ↓																
16	246 119	313 192	380 282	476 351	550 396	448 390	550 467	550 467	550 467	550 550	550 550	550 550	550 550	550 550	550 550	550 550
17		277 159	336 234	420 291	550 366	395 324	495 400	550 443	550 443	512 488	550 526	550 526	550 526	550 526	550 526	550 526
18		246 134	299 197	374 245	507 317	352 272	441 339	530 397	550 408	456 409	508 456	550 490	550 490	550 490	550 490	550 490
19		221 113	268 167	335 207	454 269	315 230	395 287	475 336	550 383	408 347	455 386	547 452	550 455	550 455	550 455	550 455
20		199 97	241 142	302 177	409 230	284 197	356 246	428 287	525 347	368 297	410 330	493 386	550 426	550 426	550 426	550 426
21			218 123	273 153	370 198	257 170	322 212	368 248	475 299	333 255	371 285	447 333	503 373	548 405	550 406	550 406
22			199 106	249 132	337 172	234 147	293 184	353 215	432 259	303 222	337 247	406 289	456 323	498 351	550 385	550 385
23			181 93	227 116	308 150	214 128	268 160	322 188	395 226	277 194	308 216	371 252	418 282	455 307	507 339	550 363
24			166 81	208 101	282 132	196 113	245 141	295 165	362 199	254 170	283 189	340 221	384 248	418 269	465 298	550 346
25						180 100	226 124	272 145	334 175	234 150	260 167	313 195	353 219	384 238	428 263	514 311
26						166 88	209 110	251 129	308 156	216 133	240 148	289 173	326 194	355 211	395 233	474 276
27						154 79	193 98	233 115	285 139	200 119	223 132	268 155	302 173	329 188	366 208	439 246
28						143 70	180 88	216 103	265 124	186 106	207 118	249 138	281 155	306 168	340 186	408 220

29															173 95	193 106	232 124	261 139	285 151	317 167	380 198
30															161 86	180 96	216 112	244 126	266 137	296 151	355 178
31															151 78	168 87	203 101	228 114	249 124	277 137	332 161
32															142 71	158 79	190 92	214 103	233 112	259 124	311 147

JOIST DESIGNATION	18K3	18K4	18K5	18K6	18K7	18K9	18K10	20K3	20K4	20K5	20K6	20K7	20K9	20K10	22K4	22K5	22K6	22K7	22K9	22K10	22K11
Depth (in.) × 25.4 for mm	18	18	18	18	18	18	18	20	20	20	20	20	20	20	22	22	22	22	22	22	22
Approx. Wt. (lbs./ft.) × 14.59 for N/m	6.6	7.2	7.7	8.5	9.0	10.2	11.7	6.7	7.6	8.2	8.9	9.3	10.8	12.2	8.0	8.8	9.2	9.7	11.3	12.6	13.8
*Span (ft.) × 304.8 for mm ↓																					
18	550 550	550 550	550 550	550 550	550 550	550 550	550 550														
19	514 494	550 523	550 523	550 523	550 523	550 523	550 523														
20	463 423	550 490	550 490	550 490	550 490	550 490	550 490	517 517	550 550	550 550	550 550	550 550	550 550	550 550							
21	420 364	506 426	550 460	550 460	550 460	550 460	550 460	468 453	550 520	550 520	550 520	550 520	550 520	550 520							
22	382 316	460 370	518 414	550 438	550 438	550 438	550 438	426 393	514 461	550 490	550 490	550 490	550 490	550 490	550 548	550 548	550 548	550 548	550 548	550 548	550 548
23	349 276	420 323	473 362	516 393	550 418	550 418	550 418	389 344	469 402	529 451	550 468	550 468	550 468	550 468	518 491	550 518	550 518	550 518	550 518	550 518	550 518
24	320 242	385 284	434 318	473 345	526 382	550 396	550 396	357 302	430 353	485 396	528 430	550 448	550 448	550 448	475 431	536 483	550 495	550 495	550 495	550 495	550 495
25	294 214	355 250	400 281	435 305	485 337	550 377	550 377	329 266	396 312	446 350	486 380	541 421	550 426	550 426	438 381	493 427	537 464	550 474	550 474	550 474	550 474
26	272 190	328 222	369 249	402 271	448 299	538 354	550 361	304 236	366 277	412 310	449 337	500 373	550 405	550 405	404 338	455 379	496 411	550 454	550 454	550 454	550 454

(Continued)

STANDARD LOAD TABLE—OPEN WEB STEEL, JOISTS, K-SERIES—(Continued)

JOIST DESIGNATION	18K3	18K4	18K5	18K6	18K7	18K9	18K10	20K3	20K4	20K5	20K6	20K7	20K9	20K10	22K4	22K5	22K6	22K7	22K9	22K10	22K11
Depth (in.)																					
× 25.4 for mm	18	18	18	18	18	18	18	20	20	20	20	20	20	20	22	22	22	22	22	22	22
Approx. Wt. (lbs./ft.)	6.6	7.2	7.7	8.5	9.0	10.2	11.7	6.7	7.6	8.2	8.9	9.3	10.8	12.2	8.0	8.8	9.2	9.7	11.3	12.6	13.8
× 14.59 for N/m																					
*Span (ft.) × 304.8 for mm ↓																					
27	252 169	303 198	342 222	372 241	415 267	498 315	550 347	281 211	339 247	382 277	416 301	463 333	550 389	550 389	374 301	422 337	459 367	512 406	550 432	550 432	550 432
28	234 151	282 177	318 199	346 216	385 239	463 282	548 331	261 189	315 221	355 248	386 269	430 298	517 353	550 375	348 270	392 302	427 328	475 364	550 413	550 413	550 413
29	218 136	263 159	296 179	322 194	359 215	431 254	511 298	243 170	293 199	330 223	360 242	401 268	482 317	550 359	324 242	365 272	398 295	443 327	532 387	550 399	550 399
30	203 123	245 144	276 161	301 175	335 194	402 229	477 269	227 153	274 179	308 201	336 218	374 242	450 286	533 336	302 219	341 245	371 266	413 295	497 349	550 385	550 385
31	190 111	229 130	258 146	281 158	313 175	376 207	446 243	212 138	256 162	289 182	314 198	350 219	421 259	499 304	283 198	319 222	347 241	387 267	465 316	550 369	550 369
32	178 101	215 118	242 132	264 144	294 159	353 188	418 221	199 126	240 147	271 165	295 179	328 199	395 235	468 276	265 180	299 201	326 219	363 242	436 287	517 337	549 355
33	168 92	202 108	228 121	248 131	276 145	332 171	393 201	187 114	226 134	254 150	277 163	309 181	371 214	440 251	249 164	281 183	306 199	341 221	410 261	486 307	532 334
34	158 84	190 98	214 110	233 120	260 132	312 156	370 184	176 105	212 122	239 137	261 149	290 165	349 195	414 229	235 149	265 167	288 182	321 202	386 239	458 280	516 314
35	149 77	179 90	202 101	220 110	245 121	294 143	349 168	166 96	200 112	226 126	246 137	274 151	329 179	390 210	221 137	249 153	272 167	303 185	364 219	432 257	494 292
36	141 70	169 82	191 92	208 101	232 111	278 132	330 154	157 88	189 103	213 115	232 125	259 139	311 164	369 193	209 126	236 141	257 153	286 169	344 201	408 236	467 269
37								148 81	179 95	202 106	220 115	245 128	294 151	349 178	198 116	223 130	243 141	271 156	325 185	386 217	442 247
38								141 74	170 87	191 98	208 106	232 118	279 139	331 164	187 107	211 119	230 130	256 144	308 170	366 200	419 228

39									133 69	161 81	181 90	198 98	220 109	265 129	314 151	178 98	200 110	218 120	243 133	292 157	347 185	397 211
40									127 64	153 75	172 84	188 91	209 101	251 119	298 140	169 91	190 102	207 111	231 123	278 146	330 171	377 195
41																161 85	181 95	197 103	220 114	264 135	314 159	359 181
42																153 79	173 83	188 96	209 106	252 126	299 148	342 168
43																146 73	165 82	179 89	200 99	240 117	265 138	326 157
44																139 68	157 76	171 83	191 92	229 109	272 128	311 146

JOIST DESIGNATION	24K4	24K5	24K6	24K7	24K8	24K9	24K10	24K12	26K5	26K6	26K7	26K8	26K9	26K10	26K12	28K6	28K7	28K8	28K9	28K10	28K12	
Depth (in.) × 25.4 for mm	24	24	24	24	24	24	24	24	26	26	26	26	26	26	26	28	28	28	28	28	28	
Approx. Wt. (lbs./ft.) × 14.59 for N/m	8.4	9.3	9.7	10.1	11.5	12.0	13.1	16.0	9.8	10.6	10.9	12.1	12.2	13.8	16.6	11.4	11.8	12.7	13.0	14.3	17.1	
*Span (ft.) × 304.8 for mm ↓																						
24	550 516	550 544	550 544	550 544	550 544	550 544	550 544	550 544														
25	479 456	540 511	550 520	550 520	550 520	550 520	550 520	550 520														
26	442 405	499 453	543 493	550 499	550 499	550 499	550 499	550 499	542 535	550 541	550 541	550 541	550 541	550 541	550 541							
27	410 361	462 404	503 439	550 479	550 479	550 479	550 479	550 479	502 477	547 519	550 522	550 522	550 522	550 522	550 522							
28	381 323	429 362	467 393	521 436	550 456	550 456	550 456	550 456	466 427	508 464	550 501	550 501	550 501	550 501	550 501	548 541	550 543	550 543	550 543	550 543	550 543	550 543
29	354 290	400 325	435 354	485 392	536 429	550 436	550 436	550 436	434 384	473 417	527 463	550 479	550 479	550 479	550 479	511 486	550 522	550 522	550 522	550 522	550 522	550 522
30	331 262	373 293	406 319	453 353	500 387	544 419	550 422	550 422	405 346	441 377	492 417	544 457	550 459	550 459	550 459	477 439	531 486	550 500	550 500	550 500	550 500	550 500

(Continued)

STANDARD LOAD TABLE—OPEN WEB STEEL JOISTS, K-SERIES—(Continued)

JOIST DESIGNATION	24K4	24K5	24K6	24K7	24K8	24K9	24K10	24K12	26K5	26K6	26K7	26K8	26K9	26K10	26K12	28K6	28K7	28K8	28K9	28K10	28K12
Depth (in.) × 25.4 for mm	24	24	24	24	24	24	24	24	26	26	26	26	26	26	26	28	28	28	28	28	28
Approx. Wt. (lbs./ft.) × 14.59 for N/m	8.4	9.3	9.7	10.1	11.5	12.0	13.1	16.0	9.8	10.6	10.9	12.1	12.2	13.8	16.6	11.4	11.8	12.7	13.0	14.3	17.1
*Span (ft.) × 304.8 for mm ↓																					
31	310 237	349 266	380 289	424 320	468 350	510 379	550 410	550 410	379 314	413 341	460 378	509 413	550 444	550 444	550 444	446 397	497 440	550 480	550 480	550 480	550 480
32	290 215	327 241	357 262	397 290	439 318	478 344	549 393	549 393	356 285	387 309	432 343	477 375	519 407	549 431	549 431	418 361	466 400	515 438	549 463	549 463	549 463
33	273 196	308 220	335 239	373 265	413 289	449 313	532 368	532 368	334 259	364 282	406 312	448 342	488 370	532 404	532 404	393 329	438 364	484 399	527 432	532 435	532 435
34	257 179	290 201	315 218	351 242	388 264	423 286	502 337	516 344	315 237	343 257	382 285	422 312	459 338	516 378	516 378	370 300	412 333	456 364	496 395	516 410	516 410
35	242 164	273 184	297 200	331 221	366 242	399 262	473 308	501 324	297 217	323 236	360 261	398 286	433 310	501 356	501 356	349 275	389 305	430 333	468 361	501 389	501 389
36	229 150	258 169	281 183	313 203	346 222	377 241	447 283	487 306	280 199	305 216	340 240	376 263	409 284	486 334	487 334	330 252	367 280	406 306	442 332	487 366	487 366
37	216 138	244 155	266 169	296 187	327 205	356 222	423 260	474 290	265 183	289 199	322 221	356 242	387 262	460 308	474 315	312 232	348 257	384 282	418 305	474 344	474 344
38	205 128	231 143	252 156	281 172	310 189	338 204	401 240	461 275	251 169	274 184	305 204	337 223	367 241	436 284	461 299	296 214	329 237	384 260	396 282	461 325	461 325
39	195 118	219 132	239 144	266 159	294 174	320 189	380 222	449 261	238 156	260 170	289 188	320 206	348 223	413 262	449 283	280 198	313 219	346 240	376 260	447 306	449 308
40	185 109	208 122	227 133	253 148	280 161	304 175	361 206	438 247	227 145	247 157	275 174	304 191	331 207	393 243	438 269	266 183	297 203	328 222	357 241	424 284	438 291
41	176 101	198 114	216 124	241 137	266 150	290 162	344 191	427 235	215 134	235 146	262 162	289 177	315 192	374 225	427 256	253 170	283 189	312 206	340 224	400 263	427 277
42	168 94	189 106	206 115	229 127	253 139	276 151	327 177	417 224	205 125	224 136	249 150	275 164	300 178	356 210	417 244	241 158	269 175	297 192	324 208	384 245	417 264

43	160 88	180 98	196 107	219 118	242 130	263 140	312 165	406 213	196 116	213 126	238 140	263 153	286 166	339 195	407 232	230 147	257 163	284 179	309 194	367 228	407 252
44	153 82	172 92	187 100	209 110	231 121	251 131	298 154	387 199	187 108	204 118	227 131	251 143	273 155	324 182	398 222	220 137	245 152	271 167	295 181	350 212	398 240
45	146 76	164 86	179 93	199 103	220 113	240 122	285 144	370 185	179 101	194 110	217 122	240 133	261 145	310 170	389 212	210 128	234 142	259 156	282 169	334 198	389 229
46	139 71	157 80	171 87	191 97	211 106	230 114	272 135	354 174	171 95	186 103	207 114	229 125	250 135	296 159	380 203	201 120	224 133	248 146	270 158	320 186	380 219
47	133 67	150 75	164 82	183 90	202 99	220 107	261 126	339 163	164 89	178 96	199 107	219 117	239 127	284 149	369 192	192 112	214 125	237 136	258 148	306 174	372 210
48	128 63	144 70	157 77	175 85	194 93	211 101	250 118	325 153	157 83	171 90	190 100	210 110	229 119	272 140	353 180	184 105	208 117	227 128	247 139	294 163	365 201
49									150 78	164 85	183 94	202 103	220 112	261 131	339 169	177 99	197 110	218 120	237 130	282 153	357 193
50									144 73	157 80	175 89	194 97	211 105	250 124	325 159	170 93	189 103	209 113	228 123	270 144	350 185
51									139 69	151 75	168 83	186 91	203 99	241 116	313 150	163 88	182 97	201 106	219 115	260 136	338 175
52									133 65	145 71	162 79	179 86	195 93	231 110	301 142	157 83	175 92	193 100	210 109	250 128	325 165
53																151 78	168 87	186 95	203 103	240 121	313 156
54																145 74	162 82	179 89	195 97	232 114	301 147
55																140 70	156 77	173 85	188 92	223 108	290 139
56																135 66	151 73	166 80	181 87	215 102	280 132

(Continued)

STANDARD LOAD TABLE—OPEN WEB STEEL JOISTS, K-SERIES—(Continued)

JOIST DESIGNATION	30K7	30K8	30K9	30K10	30K11	30K12
Depth (in.)	30	30	30	30	30	30
× 25.4 for mm						
Approx. Wt. (lbs./ft.)	12.3	13.2	13.4	15.0	16.4	17.6
× 14.59 for N/m						
*Span (ft.)						
× 304.8 for mm						
↓						
30	550 543	550 543	550 543	550 543	550 543	550 543
31	534 508	550 520	550 520	550 520	550 520	550 520
32	501 461	549 500	549 500	549 500	549 500	549 500
33	471 420	520 460	532 468	532 468	532 468	532 468
34	443 384	490 420	516 441	516 441	516 441	516 441
35	418 351	462 384	501 415	501 415	501 415	501 415
36	395 323	436 353	475 383	487 392	487 392	487 392
37	373 297	413 325	449 352	474 374	474 374	474 374
38	354 274	391 300	426 325	461 353	461 353	461 353
39	336 253	371 277	404 300	449 333	449 333	449 333
40	319 234	353 256	384 278	438 315	438 315	438 315
41	303 217	335 238	365 258	427 300	427 300	427 300
42	289 202	320 221	348 240	413 282	417 284	417 284
43	276 188	305 206	332 223	394 263	407 270	407 270

44	263 176	291 192	317 208	376 245	398 258	398 258
45	251 164	278 179	303 195	359 229	389 246	389 246
46	241 153	266 168	290 182	344 214	380 236	380 236
47	230 144	255 157	277 171	329 201	372 226	372 226
48	221 135	244 148	266 160	315 188	362 215	365 216
49	212 127	234 139	255 150	303 177	347 202	357 207
50	203 119	225 130	245 141	291 166	333 190	350 199
51	195 112	216 123	235 133	279 157	320 179	343 192
52	188 106	208 116	226 126	268 148	308 169	336 184
53	181 100	200 109	218 119	258 140	296 159	330 177
54	174 94	192 103	209 112	249 132	285 150	324 170
55	168 89	185 98	202 106	240 125	275 142	312 161
56	162 84	179 92	195 100	231 118	265 135	301 153
57	156 80	173 88	188 95	223 112	256 128	290 145
58	151 76	167 83	181 90	215 106	256 121	290 137
59	146 72	161 79	175 86	208 101	239 115	271 130
60	141 69	156 75	169 81	201 96	231 109	262 124

## STANDARD SPECIFICATIONS FOR LONGSPAN STEEL JOISTS, LH-SERIES AND DEEP LONGSPAN STEEL JOISTS, DLH-SERIES

Adopted by the Steel Joist Institute February 15, 1978  
Revised to November 12, 1991

### SECTION 100 SCOPE

These specifications cover the design, manufacture and use of longspan steel joists, LH Series, and deep longspan steel joists, DLH Series.

### SECTION 101 DEFINITION

The term "Longspan Steel Joist, LH series, and Deep Longspan Steel Joists, DLH Series," as used herein, refers to open-web, load-carrying members utilizing hot-rolled or cold-formed steel, including cold-formed steel whose yield strength\* has been attained by cold working. LH Series are suitable for the direct support of floors and roof decks in buildings and DLH Series are suitable for the direct support of roof decks in buildings.

The design of LH- and DLH-Series joist chord or web sections shall be based on a yield strength of at least 36,000 psi (250 MPa) but not greater than 50,000 psi (345 MPa). Steel used for LH- and DLH-Series joist chord or web sections shall have a minimum yield strength determined in accordance with one of the procedures specified in the Section 102.2, which is equal to the yield strength assumed in the design. LH- and DLH-Series joists shall be designed in accordance with these specifications to support the loads given in the attached Standard Load Tables for LH- and DLH-Series joists.

Standard Specifications and Load Tables: Longspan Steel Joists LH-Series and Deep Longspan Steel Joists DLH-Series. Copyright 1992. Steel Joist Institute.

### SECTION 102 MATERIALS

#### 102.1 STEEL

The steel used in the manufacture of chord and web sections shall conform to one of the following ASTM Specifications of latest adoption:

- Structural steel, ASTM A36/A36M.
- High-Strength Low-Alloy Structural Steel, ASTM A242/A242M.
- High-Strength Low-Alloy Structural Manganese Vanadium Steel, ASTM A441.
- Hot-Rolled Carbon Steel Sheet and Strip, Structural Quality ASTM A570/A570M.
- High-Strength Low-Alloy Columbium-Vanadium Steels of Structural Quality ASTM A572/A572M, Grades 42, 45, and 50.
- High-Strength Low-Alloy Structural Steel with 50,000 psi (345 MPa) Minimum Yield Point to 4 inches (102 mm) thick, ASTM A588/A588M.

---

\*The term "yield strength" as used herein shall designate the yield level of a material as determined by the applicable method outlined in paragraph 13—"Yield Strength", or paragraph 12—"Yield Point," of ASTM A370. "Mechanical Testing of Steel Products," or as specified in Section 102.2 of this Specification.

- Steel Sheet and Strip, Hot-Rolled and Cold-Rolled, High-Strength, Low-Alloy, with Improved Corrosion Resistance, ASTM A606.
- Steel Sheet and Strip, Hot-Rolled and Cold-Rolled, High-Strength, Low-Alloy, Columbium and/or Vanadium, ASTM A607. Grades 45 and 50.
- Steel, Cold-Rolled Sheet, Carbon Structural, ASTM A611. Grade D.

or shall be of suitable quality ordered or produced to other than the listed specifications, provided that such material in the state used for final assembly and manufacture is weldable and is proved by tests performed by the producer or manufacturer to have the properties specified in Section 102.2.

### 102.2 MECHANICAL PROPERTIES

The yield strength used as a basis for the design stresses prescribed in Section 103 shall be at least 36,000 psi (250 MPa) but shall not be greater than 50,000 psi (345 MPa). Evidence that the steel furnished meets or exceeds the design yield strength shall, if requested, be provided in the form of an affidavit or by witnessed or certified test reports.

For material used without consideration of increase in yield strength resulting from cold forming, the specimens shall be taken from as-rolled material. In the case of material the mechanical properties of which conform to the requirements of one of the listed specifications, test specimens and procedure shall conform to those of such specifications and ASTM A370.

In the case of material the mechanical properties of which do not conform to the requirements of one of the listed specifications, the test specimens and procedure shall conform to the applicable requirements of ASTM A370 and the specimens shall exhibit a yield strength equal to or exceeding the design yield strength and an elongation of not less than (a) 20 percent in 2 inches (51 mm) for sheet and strip or (b) 18 percent in 8 inches (203 mm) for plates, shapes and bars with adjustments for thickness for plates, shapes and bars as prescribed in ASTM A36/A36M, A242/A242M, A441, A572/A572M, and A588/A588M whichever specification is applicable on the basis of design yield strength. The number of tests shall be as prescribed in ASTM A6 for plates, shapes, and bars; and ASTM A570/A570M, A606, A607, and A611 for sheet and strip.

If as-formed strength is utilized, the test reports shall show the results of tests performed on full section specimens in accordance with the provisions of Sections 3.1.1 and 6.3 of the AISI Specification for the Design of Cold-Formed Steel Structural Members, and shall indicate compliance with these provisions and with the following additional requirements:

1. The yield strength measured in the tests shall equal or exceed the design yield strength.
2. Where tension tests are made for acceptance and control purposes the tensile strength shall be at least 6 percent greater than the yield strength of the section.
3. Where compression tests are used for acceptance and control purposes the specimen shall withstand a gross shortening of 2 percent of its original length without cracking. The length of specimen shall not be greater than 20 times its least radius of gyration.
4. If any test specimen fails to pass the requirements of subparagraphs 1, 2 or 3 above, as applicable, two retests shall be made of specimens for the same lot. Failure of one of the retest specimens to meet such requirements shall be cause for rejection of the lot represented by the specimens.

### 102.3 WELDING ELECTRODES

The following electrodes shall be used for arc welding:

(a) For connected members both having a specified minimum yield strength greater than 36,000 psi (250 MPa)

AWS A5.1 or A5.5, E70XX

AWS A5.17, F7X-EXXX flux-electrode combination

AWS A5.18, E70S-X or E70U-1

AWS A5.20, E70T-X

(b) For connected members both having a specified minimum yield strength of 36,000 psi (250 MPa), or one having a specified minimum yield strength of 36,000 psi (250 MPa) and the other having a specified minimum yield strength greater than 36,000 psi (250 MPa)

AWS A5.1, E60XX

AWS A5.17, F6X-EXXX flux-electrode combination

AWS A5.20, E60T-X

or any of those listed in Section 102.3 (a).

Other welding methods, providing equivalent strength as demonstrated by tests, may be used.

#### 102.4 PAINT

The standard shop paint is a primer coat intended to protect the steel for only a short period of exposure in ordinary atmospheric conditions and shall be considered an impermanent and provisional coating.

The Standard shop paint shall conform to one of the following:

(a) Steel Structures Painting Council Specification 15-68T, Type I (red oxide).

(b) Federal Specification TT-P-636 (red oxide).

(c) Or, shall be a shop paint which meets the minimum performance requirements of one of the above listed specifications.

### SECTION 103 DESIGN AND MANUFACTURE

#### 103.1 METHOD

Joists shall be designed in accordance with these specifications as simply supported uniformly loaded trusses supporting a floor or roof deck so constructed as to brace the top chord of the joists against lateral buckling. Where any applicable design feature is not specifically covered herein, the design shall be in accordance with the following specifications of latest adoption:

(a) American Institute of Steel Construction Specification for the Design, Fabrication and Erection of Structural Steel for Buildings, where the material used consists of plates, shapes or bars.

(b) American Iron and Steel Institute Specification for the Design of Cold-Formed Steel Structural Members, for members which are cold-formed from sheet or strip material.

#### 103.2 UNIT STRESSES

Joists shall have their components so proportioned that the unit stresses in pounds per square inch (MPa) shall not exceed the following where  $F_y$  is the yield strength defined in Section 102.2:

(a) **Tension:**

All members  $F_t = 0.6 F_y$

(b) **Compression:**

For members with  $Kl/r$  less than  $C_c$ :

$$F_a = \frac{\left[1 - \frac{(Kl/r)^2}{2C_c^2}\right] Q F_y}{\frac{5}{3} + \frac{3}{8} \left(\frac{Kl/r}{C_c}\right) - \frac{1}{8} \left(\frac{Kl/r}{C_c}\right)^3} \text{ where } C_c = \sqrt{\frac{2\pi^2 E}{Q F_y}} \text{ and}$$

where  $Q$  is a form factor equal to unity except when the width-thickness ratio of one or more elements of the profile exceeds the limits specified in the AISC Specifications, Section B5 (Allowable Stress Design) for hot-rolled sections and in the AISI Specification, Section 3., for cold-formed sections; and where  $K$  is a length factor used to determine the effective slenderness ratio as shown in Table No. 103.3.1.

For members with  $Kl/r$  greater than  $C_c$ :

$$F_a = \frac{12\pi^2 E}{23 (Kl/r)^2}$$

In the above formulas  $Kl/r$  is the appropriate effective slenderness ratio as determined from Section 103.3 and "E" is equal to 29,000,000 psi (200 000 MPa).

(c) **Bending:**

For chords, and for web members other than solid rounds . . . . .  $F_b = 0.6F_y$

For web members of solid round cross section . . . . .  $F_b = 0.9F_y$

For bearing plates . . . . .  $F_b = 0.75F_y$

(d) **Weld Stresses:**

Shear at throat of fillet welds:

Made with E70 series electrodes or F7X-EXXX  
flux-electrode combinations . . . . . 21,000 psi (145 MPa)

Made with E60 series electrodes or F6X-EXXX  
flux-electrode combinations . . . . . 18,000 psi (124 MPa)

Tension or compression on groove or butt welds shall be the same as those specified for the connected material.

### 103.3 MAXIMUM SLENDERNESS RATIOS

The slenderness ratios,  $l/r$  and  $1.0 l_g/r$ , of members as a whole or any component part shall not exceed the values given in Table No. 103.3.1 Parts A.

The effective slenderness ratio,  $Kl/r^*$ , to be used in calculating the allowable stresses  $F_a$  and  $F'_e$  is the largest value as determined from Table No. 103.3.1, Parts B and C.

In compression members when fillers or ties are used, they shall be spaced so that the  $l_g/r_z$  ratio of each component does not exceed the governing  $l/r$  ratio of the member as a whole. The terms are defined as follows:

$l$  = length center-to-center of panel points, except  $l = 36$  inches (914 mm) for calculating  $l/r_y$  of top chord member.

$l_g$  = maximum length center-to-center between panel point and filler (tie), or between adjacent fillers (ties).

$r_x$  = member radius of gyration in the plane of the joist.

$r_y$  = member radius of gyration out of the plane of the joist.

$r_z$  = least radius of gyration of a member component.

---

\*See AISC Specification Section C2.1 and P.N. Chod and T.V. Galambos, Compression Chords Without Fillers in Longspan Steel Joists, Research Report No. 36, June 1975 Structural Division, Civil Engineering Department, Washington University, St. Louis, Mo.

**TABLE 103.3.1**  
**MAXIMUM AND EFFECTIVE SLENDERNESS RATIOS**

<b>I TOP CHORD INTERIOR PANEL</b>			
A. The slenderness ratios, $1.0 l/r$ and $1.0 l_s/r$ , of members as a whole or any component part shall not exceed 90.			
B. The effective slenderness ratio to determine "F <sub>a</sub> "			
1. With fillers or ties	$0.75l/r_x$	$1.0l/r_y$	$1.0l_s/r_z$
2. Without fillers or ties		$0.75l/r_z$	
3. Single component members	$0.75l/r_x$	$1.0l/r_y$	
C. The effective slenderness ratio to determine "F' <sub>e</sub> "			
1. With fillers or ties	$0.75l/r_x$		
2. Without fillers or ties	$.075l/r_x$		
3. Single component members	$.075l/r_x$		
<b>II TOP CHORD END PANEL</b>			
A. The slenderness ratios, $1.0l/r$ and $1.0l_s/r$ , of members as a whole or any component part shall not exceed 120.			
B. The effective slenderness ratio to determine "F <sub>a</sub> "			
1. With fillers or ties	$1.0l/r_x$	$1.0l/r_y$	$1.0l_s/r_z$
2. Without fillers or ties		$1.0l/r_z$	
3. Single component members	$1.0l/r_x$	$1.0l/r_y$	
C. The effective slenderness ratio to determine "F' <sub>e</sub> "			
1. With fillers or ties	$1.0l/r_x$		
2. Without fillers or ties	$1.0l/r_x$		
3. Single component members	$1.0l/r_x$		
<b>III TENSION MEMBERS—CHORDS AND WEBS</b>			
A. The slenderness ratios, $1.0l/r$ and $1.0l_s/r$ , of members as a whole or any component part shall not exceed 240.			
<b>IV COMPRESSION WEB MEMBERS</b>			
A. The slenderness ratios, $1.0l/r$ and $1.0l_s/r$ , of members as a whole or any component part shall not exceed 200.			
B. The effective slenderness ratio to determine "F <sub>a</sub> "			
1. With fillers or ties	$0.75l/r_x$	$1.0l/r_y$	$1.0l_s/r_z$
2. Without fillers or ties		$1.0l/r_z$	
3. Single component members	$0.75l/r_x^*$	$1.0l/r_y$	
*If moment-resistant weld groups are not used at the ends of a crimped, first primary compression web member, then $1.2l/r_x$ must be used.			

### 103.4 MEMBERS

#### (a) Chords

The bottom chord shall be designed as an axially loaded tension member.

The top chord shall be designed as a continuous member subject to combined axial and bending stresses and shall be so proportioned that

$$f_a + f_b \leq 0.6F_y, \text{ at the panel point; and}$$

$$\frac{f_a}{F_a} + \frac{C_m f_b}{\left(1 - \frac{f_a}{F_c}\right) Q F_b} \leq 1.0 \text{ at mid-panel; in which}$$

$C_m = 1 - 0.3f_a/F'_c$  for end panels

$C_m = 1 - 0.4f_a/F'_c$  for interior panels

$f_a$  = Computed axial unit compressive stress

$f_b$  = Computed bending unit compressive stress at the point under consideration

$F_a$  = Permissible axial unit compressive stress based on  $Kl/r$ .

$F_b$  = Permissible bending unit stress;  $0.6F_y$ .

$$F'_c = \frac{12\pi^2 E}{23(Kl/r_x)^2}$$

$r_x$  = radius of gyration about the axis of bending.

$Q$  = form factor as defined in Section 103.2 (b).

The radius of gyration of the top chord about its vertical axis shall not be less than  $l/170$  where  $l$  is the spacing in inches (mm) between lines of bridging as specified in Section 104.5 (d).

The top chord shall be considered as stayed laterally by the floor or roof deck, provided the requirements of Section 104.9 (e) of these specifications are met.

#### (b) Web

The vertical shears to be used in the design of the web members shall be determined from full uniform loading but such vertical shear shall not be less than 25 percent of the end reaction. Interior vertical web members used in modified Warren-type web systems shall be designed to resist the gravity loads supported by the member plus  $1/2$  of 1.0 percent of the top chord axial force.

#### (c) Depth

Joists may have either parallel chords or a top chord slope of  $1/8$  inch per foot (1:96). The depth, for the purpose of design, in all cases shall be the depth at midspan.

#### (d) Eccentricity

Members connected at a joint shall have their center of gravity lines meet at a point, if practical. Eccentricity on either side of the neutral axis of chord members may be neglected when it does not exceed the distance between the neutral axis and the back of the chord. Otherwise, provision shall be made for the stresses due to eccentricity. Ends of joists shall be proportioned to resist bending produced by eccentricity at the support.

In those cases where a single angle compression member is attached to the outside of the stem of a tee or double-angle chord, due consideration shall be given to eccentricity.

#### (e) Extended ends

Extended top chords or full-depth cantilever ends require the special attention of the specifying professional. The magnitude and location of the design loads to be supported, the deflection requirements and the proper bracing shall be clearly indicated on the structural drawings.

The magnitude and location of the design loads to be supported, the deflection requirements, and the proper bracing shall be clearly indicated on the structural drawings.

### 103.5 CONNECTIONS

#### (a) Methods

Joint connections and splices shall be made by attaching the members to one another by arc or resistance welding or other approved method.

1) Welded connections.

a) Selected welds shall be inspected visually by the manufacturer. Prior to this inspection, weld slag shall be removed.

b) Cracks are not acceptable and shall be repaired.

c) Thorough fusion shall exist between layers of weld metal and between weld metal and base metal for the required design length of the weld; such fusion shall be verified by visual inspection.

d) Unfilled weld craters shall not be included in the design length of the weld.

e) Undercut shall not exceed  $1/16$  inch (2 mm) for welds oriented parallel to the principal stress.

f) The sum of surface (piping) porosity diameters shall not exceed  $1/16$  inch (2 mm) in any 1 inch (26 mm) of design weld length.

g) Weld spatter that does not interfere with paint coverage is acceptable.

2. Welding program.

Manufacturers shall have a program for establishing weld procedures and operator qualification and for weld sampling and testing.

3. Weld inspection by Outside Agencies (See Section 104.13 of these specifications).

The agency shall arrange for visual inspection to determine that welds meet the acceptance standards of Section 103.5 a. 1 above. Ultrasonic X-ray, and magnetic particle testing are inappropriate for joists due to the configuration of the components and welds.

(b) **Strength**

Joint connections shall develop the maximum force due to any of the design loads, but not less than 50 percent of the allowable strength of the member in tension or compression, whichever force is the controlling factor in the selection of the member.

(c) **Shop Splices**

Shop splices may occur at any point in chord or web members. Splices shall be designed for the member force but not less than 50 percent of the allowable member strength. Members containing a butt weld splice shall develop an ultimate tensile force of at least 57,000 psi (393 MPa) times the full design area of the chord or web. The term "member" shall be defined as all component parts, comprising the chord or web, at the point of splice.

(d) **Field splices**

Field splices shall be designed by the manufacturer and may be either bolted or welded. Splices shall be designed for the member force, but not less than 50 percent of the allowable member strength.

**103.6 CAMBER**

Joists shall have approximate cambers in accordance with the following:

<b>Top Chord Length</b>	<b>Approximate Camber</b>
20'-0" (6096 mm)	$1/4$ " (7 mm)
30'-0" (9144 mm)	$3/8$ " (10 mm)
40'-0" (12 192 mm)	$5/8$ " (16 mm)
50'-0" (15 240 mm)	1" (26 mm)
60'-0" (18 288 mm)	$1\ 1/2$ " (38 mm)
70'-0" (21 336 mm)	2" (51 mm)
80'-0" (24 384 mm)	$2\ 3/4$ " (70 mm)
90'-0" (27 432 mm)	$3\ 1/2$ " (89 mm)

100'-0" (30 480 mm)	4 <sup>1</sup> / <sub>4</sub> " (108 mm)
110'-0" (33 528 mm)	5" (127 mm)
120'-0" (36 576 mm)	6" (152 mm)
130'-0" (39 621 mm)	7" (178 mm)
140'-0" (42 672 mm)	8" (203 mm)
144'-0" (43 890 mm)	8 <sup>1</sup> / <sub>2</sub> " (216 mm)

**103.7 SHOP PAINTING**

Joists and accessories shall receive one shop coat of protective paint as specified in Section 102.4.

**103.8 VERIFICATION OF DESIGN AND MANUFACTURE****(a) Design Calculations**

Companies manufacturing any LH- or DLH- Series Joists shall submit design data to the Steel Joist Institute (or an independent agency approved by the Steel Joist Institute) for verification of compliance with the SJI Specifications.

**(b) In-Plant Inspections**

Each manufacturer shall verify their ability to manufacture LH- Series and DLH- Series Joists through periodic In-Plant Inspections. Inspections shall be performed by an independent agency approved by the Steel Joist Institute. The frequency, manner of inspection, and manner of reporting shall be determined by the Steel Joist Institute. The Plant inspections are not a guarantee of the quality of any specific joists or Joist Girders; this responsibility lies fully and solely with the individual manufacturer.

**SECTION 104  
APPLICATION****104.1 USAGE**

These specifications shall apply to any type of structure where floors and roof decks are to be supported directly by steel joists installed as hereinafter specified. Where joists are used other than on simple spans under uniformly distributed loading, as prescribed in Section 103.1, they shall be investigated and modified if necessary to limit the unit stresses to those listed in Section 103.2.

**CAUTION:** If a rigid connection of the bottom chord is to be made to the column or other support, it shall be made only after the application of the dead loads. The joist is then no longer simply supported and the system must be investigated for continuous frame action by the specifying professional.

The designed detail of a rigid type connection and moment plates shall be shown on the structural drawings. The moment plates shall be furnished by other than the joist manufacturer.

**104.2 SPAN**

The clear span of joists shall not exceed 24 times their depth. The term "Span" as used herein is defined as the clearspan plus 8 inches (203 mm).

**104.3 DEPTH**

The nominal depth of sloping chord joists shall be the depth at mid-span. The standard slope of the top chord shall be <sup>1</sup>/<sub>8</sub> inch per foot (1:96).

## 104.4 END SUPPORTS

### (a) Masonry and Concrete

LH- and DLH-Series joist supported by masonry or concrete are to bear on steel bearing plates and shall be designed as steel bearing. Due consideration of the end reactions and all other vertical and lateral forces shall be taken by the specifying professional in the design of the steel bearing plate and the masonry or concrete. The ends of LH- and DLH- Series joists shall extend a distance of not less than 6 inches (152 mm) over the masonry or concrete support and be anchored to the steel bearing plate. The plate shall be located not more than  $\frac{1}{2}$  inch (13 mm) from the face of the wall and shall not be less than 9 inches (229 mm) wide perpendicular to the length of the joist. It is to be designed by the specifying professional in compliance with the allowable unit stresses in Section A5.1 (Allowable Stress Design) of the A.I.S.C. Specifications of latest adoption. The steel bearing plate shall be furnished by other than the joist manufacturer.

Where it is deemed necessary to bear less than 6 inches (152 mm) over the masonry or concrete support, special consideration is to be given to the design of the steel bearing plate and the masonry or concrete by the specifying professional. The joists must bear a minimum of 4 inches (102 mm) on the steel bearing plate.

### (b) Steel

Due consideration of the end reactions and all other vertical and lateral forces shall be taken by the specifying professional in the design of the steel support. The ends of LH- or DLH-Series joists shall extend a distance of not less than 4 inches (102 mm) over the steel supports. Where it is deemed necessary to butt opposite joists over a narrow steel support with bearing less than that noted above, special ends must be specified, and such ends shall have positive attachment to the support, either by bolting or welding.

## 104.5 BRIDGING

### (a) Horizontal

Horizontal bridging lines shall consist of two continuous horizontal steel members, one attached to the top chord and the other attached to the bottom chord. The ( $l/r$ ) of the bridging member shall not exceed 300, where  $l$  is the distance in inches (mm) between attachments and  $r$  is the least radius of gyration of the bridging member.

### (b) Diagonal

Diagonal bridging lines shall consist of cross bracing with  $l/r$  ratio of not more than 200, where  $l$  is the distance in inches between connections and  $r$  is the least radius of gyration of the bracing member. Where cross-bracing members are connected at their point of intersection, the  $l$  distance shall be taken as the distance in inches (mm) between connections at the point of intersection of the bracing members and the connections to the chords of the joists.

### (c) Bridging lines

For spans up through 40 feet (12 192 mm), welded horizontal bridging may be used. For spans over 40 feet (12 192 mm) through 60 feet (18 288 mm), welded horizontal bridging may be used except that one row nearest midspan shall be bolted diagonal bridging.

For spans over 60 feet (18 288 mm), bolted diagonal bridging shall be used.

### (d) Spacing

The maximum spacing of lines of bridging shall not exceed the values in Table 104.5.1. See Section 104.12 for bridging required for uplift forces.

TABLE NO. 104.5.1

LH-*Section Number	Max. Spacing of Lines of Bridging	Horizontal Bracing Force**
	× 304.8 for mm	× 4,448 for N
02 to 09 incl.	11'-0"	1100 lbs.
10 to 12 incl.	16'-0"	1100 lbs.
13 to 14 incl.	16'-0"	1400 lbs.
15 to 17 incl.	21'-0"	2700 lbs.
DLH- *Section Number	Max. Spacing of Lines of Bridging	Horizontal Bracing Forces**
	× 304.8 for mm	× 4,448 for N
10	14'-0"	1100 lbs.
11 to 12 incl.	16'-0"	1100 lbs.
13 to 14 incl.	16'-0"	1400 lbs.
15 to 17 incl.	21'-0"	2700 lbs.
18 to 19 incl.	26'-0"	3400 lbs.

Number of lines of bridging are based on joist clear span dimensions.

\*Last two digits of joist designation shown in load table.

\*\*Each connection to the chord shall resist one-half of this force.

#### (e) Connections

Connections to the chords of the steel joists shall be made by positive mechanical means or by welding, and capable of resisting a horizontal force not less than that specified in Table 104.5.1.

#### (f) Bottom Chord Bearing Joist

Where bottom chord bearing joists are utilized, there shall be a row of diagonal bridging near the support to provide lateral stability. This bridging shall be installed as the joists are set in place.

### 104.6 INSTALLATION OF BRIDGING

All bridging and bridging anchors shall be completely installed before construction loads are placed on the joists.

Bridging shall support the top and bottom chords against lateral movement during the construction period and shall hold the steel joists in the approximate position as shown on the plans.

The ends of all bridging lines terminating at walls or beams shall be anchored to resist the force shown in Table 104.5.1.

### 104.7 END ANCHORAGE

#### (a) Masonry and Concrete

Ends of LH- or DLH-Series joists resting on steel bearing plates on masonry or structural concrete shall be attached thereto with a minimum of two  $\frac{1}{4}$  inch (6 mm) fillet welds 2 inches (51 mm) long, or with two  $\frac{3}{4}$  inch (20 mm) bolts.

#### (b) Steel

Ends of LH- or DLH- Series Joists resting on steel supports shall be attached thereto with a minimum of two  $\frac{1}{4}$  inch (6 mm) fillet welds 2 inches (51 mm) long, or with two  $\frac{3}{4}$  inch (20 mm) bolts.

In steel frames, where columns are not framed in at least two directions with structural steel members, joists at column lines shall be field bolted at the columns to provide lateral stability during construction.

**(c) Uplift**

Where uplift forces are a design consideration, roof joists shall be anchored to resist such forces.

**104.8 JOIST SPACING**

Joists shall be spaced so that the loading on each joist does not exceed the allowable load given for the particular designation and clearspan in the Load Table.

**104.9 FLOORS AND ROOF DECKS**

**(a) Material**

Floors and roof decks may consist of cast-in place or precast concrete or gypsum, formed steel, wood or other suitable material capable of supporting the required load at the specified joist spacing.

**(b) Thickness**

Cast-in-place slabs shall be not less than 2 inches (51 mm) thick.

**(c) Centering**

Centering for structural slabs may be ribbed metal lath, corrugated steel sheets, paper-back welded wire fabric, removable centering or any other suitable material capable of supporting the slab at the designated joist spacing. Centering shall not cause lateral displacement or damage to the top chord of joists during installation or removal of the centering or placing of the concrete.

**(d) Bearing**

Slabs or decks shall bear uniformly along the top chords of the joists.

**(e) Attachments**

The spacing of attachments along the top chord shall not exceed 36 inches (914 mm). Such attachments of the slab or deck to the top chords of joists shall be capable of resisting the following forces.

**TABLE NO. 104.9.1**

*Section Number	Equivalent Force Required ( × 14.59 for N/m)
02 to 04 incl.	120 lbs./ft.
05 to 09 incl.	150 lbs./ft.
10 to 17 incl.	200 lbs./ft.
18 and 19 incl.	250 lbs./ft.

\*Last two digits of joist designation shown in Load Table.

**(f) Wood Nailers**

Where wood nailers are used, such nailers in conjunction with the deck or slab shall be firmly attached to the top chords of the joists in conformance with Section 104.9 (e).

**104.10 DEFLECTION**

The deflection due to the design live load shall not exceed the following:

<b>Floors:</b>	$\frac{1}{360}$ of span
<b>Roofs:</b>	$\frac{1}{360}$ of span where a plaster ceiling is attached or suspended
	$\frac{1}{240}$ of span for all other cases

The specifying professional shall give due consideration to the effects of deflection in selection of joists.

#### 104.11 PONDING

Unless a roof surface is provided with sufficient slope toward points of free drainage or adequate individual drains to prevent the accumulation of rain water, the roof system shall be investigated to assure stability under ponding conditions in accordance with Section K2 (Allowable Stress Design) of the AISC Specifications.\*

The ponding investigation shall be performed by the specifying professional.

#### 104.12 UPLIFT

Where uplift forces due to wind are a design requirement, these forces must be indicated on the contract drawings in terms of net uplift in pounds per square foot (Pa). When these forces are specified, they must be considered in the design of joists and/or bridging. A single line of bottom chord bridging must be provided near the first bottom chord panel points whenever uplift due to wind forces is a design consideration.\*\*

#### 104.13 INSPECTION

Joists shall be inspected by the manufacturer before shipment to ensure compliance of materials and workmanship with the requirements of these specifications. If the purchaser wishes an inspection of the steel joists by someone other than the manufacturer's own inspectors, he may reserve the right to do so in his "Invitation to Bid" or the accompanying "Job Specifications." Arrangements shall be made with the manufacturer for such inspection of the joists at the manufacturing shop by the purchaser's inspectors at purchaser's expense.

### SECTION 105\*\*\* HANDLING AND ERECTION

Particular attention should be paid to the erection of Longspan and Deep Longspan Steel Joists.

Care shall be exercised at all times to avoid damage through careless handling during unloading, storing and erecting. Dropping of joists shall not be permitted.

Each joist shall be adequately braced laterally before any loads are applied. If lateral support is provided by bridging, the bridging lines as defined below must be anchored to prevent lateral movement.

Hoisting cables shall not be released until one line of bolted diagonal bridging nearest midspan for spans over 40 ft. (12 192 mm) through 60 ft. (18 288 mm), two lines of bolted diagonal bridging nearest third points of the span for spans of over 60 ft. (18 288 mm) through 100 ft. (30 480 mm), and all bolted diagonal bridging lines for spans over 100 ft. (30 480 mm), are installed. Where joists are bottom bearing, the hoisting cables shall not be released until the ends are laterally restrained

\*For further reference, refer to Steel Joist Institute Technical Digest #3 "Structural Design of Steel Joist Roofs to Resist Ponding Loads."

\*\*For further reference, refer to Steel Joist Institute Technical Digest #6, "Structural Design of Steel Joist Roofs to Resist Uplift Loads."

\*\*\*For thorough coverage of this topic, refer to SJI Technical Digest #9, "Handling and Erection of Steel Joists and Joist Girders" (See page 5).

and bridging is installed as above. For ease of alignment, anchorage of joists ends in accordance with Section 104.7 should follow the installation of bridging. During the construction period, the contractor shall provide means for the adequate distribution of concentrated loads so that the carrying capacity of any joist is not exceeded.

Field welding shall not damage the joists. The total length of weld at any one cross-section on cold-formed members whose yield strength has been attained by cold working and whose as-formed strength is used in the design, shall not exceed 50 percent of the overall developed width of the cold-formed section.

**STANDARD LOAD TABLE—LONGSPAN STEEL JOISTS, LH SERIES**  
 Adopted by the Steel Joist Institute May 25, 1983. Revised to November 15, 1989.  
 Based on a Maximum Allowable Tensile Stress of 30,000 psi<sup>1</sup> (207 MPa)

The upper figures in the following table give the **total** safe uniformly distributed load-carrying capacities, in pounds per linear foot (x 14.59 for N/m), of LH-Series joists. The weight of **dead** loads, including the joists, must in all cases be deducted to determine the **live** load-carrying capacities of the joists. The approximate **dead** load of the joists may be determined from the weights per linear foot (x 14.59 for N/m) shown in the tables.

The lower figures in this load table are the **live** loads per linear foot of joist which will produce an approximate deflection of 1/360 of the span. **Live** loads which will produce a deflection of 1/240 of the span may be obtained by multiplying the lower figures by 1.5. In no case shall the total load capacity of the joists be exceeded.

This load table applies to joists with either parallel chords or standard pitched top chords. When top chords are pitched, the carrying capacities are determined by the nominal depth of the joists at center of the span. Standard top chord pitch is 1/8 inch per foot (1:96). If pitch exceeds this standard, the load table **does not** apply. The load table may be used for parallel chord joists installed to a maximum slope of 1/2 inch per foot (1:24).

When holes are required in top or bottom chords, the carrying capacities must be reduced in proportion to reduction of chord areas.

The top chords are considered as being stayed laterally by floor slab or roof deck.

The approximate joist weights per linear foot (x 14.59 for N/m) shown in these tables do **not** include accessories.

JOIST DESIGNATION	APPROX. WT. IN LBS. PER LINEAR FT. (Joists only)	DEPTH IN INCHES	SAFE LOAD* IN LBS. BETWEEN	CLEAR SPAN IN FEET																		
				× 14.59 for N/m	× 25.4 for mm	× 4.448 for N	× 304.8 for mm															
							21-24	25	26	27	28	29	30	31	32	33	34	35	36			
18LH02	10	18	12,000	468	442	418	391	367	345	324	306	289	273	259	245							
				313	284	259	234	212	193	175	160	147	135	124	114							
18LH03	11	18	13,300	521	493	467	438	409	382	359	337	317	299	283	267							
				348	317	289	262	236	213	194	177	161	148	136	124							
18LH04	12	18	15,500	604	571	535	500	469	440	413	388	365	344	325	308							
				403	367	329	296	266	242	219	200	182	167	153	141							
18LH05	15	18	17,500	694	648	614	581	543	508	476	448	421	397	375	355							
				454	414	378	345	311	282	256	233	212	195	179	164							
18LH06	15	18	20,700	809	749	696	648	605	566	531	499	470	443	418	396							
				526	469	419	377	340	307	280	254	232	212	195	180							
18LH07	17	18	21,500	840	809	780	726	678	635	595	559	526	496	469	444							
				553	513	476	428	386	349	317	288	264	241	222	204							

(Continued)

18LH08	19	18	22,400	876 577	843 534	812 496	784 462	758 427	717 387	680 351	641 320	604 292	571 267	540 246	512 226				
--------	----	----	--------	------------	------------	------------	------------	------------	------------	------------	------------	------------	------------	------------	------------	--	--	--	--

STANDARD LOAD TABLE—LONGSPAN STEEL JOISTS, LH SERIES—(Continued)

JOIST DESIGNATION	APPROX. WT. IN LBS. PER LINEAR FT. (Joists only)	DEPTH IN INCHES	SAFE LOAD* IN LBS. BETWEEN	CLEAR SPAN IN FEET																		
				× 14.59 for N/m	× 25.4 for mm	× 4.448 for N	× 304.8 for mm															
							21-24	25	26	27	28	29	30	31	32	33	34	35	36	37	38	39
18LH09	21	18	24,000	936 616	901 571	868 527	838 491	810 458	783 418	759 380	713 346	671 316	633 289	598 266	566 245							
20LH02	10	20	11,300	442 306	437 303	431 298	410 274	388 250	365 228	344 208	325 190	307 174	291 160	275 147	262 136	249 126	237 117	225 108	215 101			
20LH03	11	20	12,000	469 337	463 333	458 317	452 302	434 280	414 258	395 238	372 218	352 200	333 184	316 169	299 156	283 143	269 133	255 123	243 114			
20LH04	12	20	14,700	574 428	566 406	558 386	528 352	496 320	467 291	440 265	416 243	393 223	372 205	353 189	335 174	318 161	303 149	289 139	275 129			
20LH05	14	20	15,800	616 459	609 437	602 416	595 395	571 366	544 337	513 308	484 281	458 258	434 238	411 219	390 202	371 187	353 173	336 161	321 150			
20LH06	15	20	21,100	822 606	791 561	763 521	723 477	679 427	635 386	596 351	560 320	527 292	497 267	469 246	444 226	421 209	399 192	379 178	361 165			
20LH07	17	20	22,500	878 647	845 599	814 556	786 518	760 484	711 438	667 398	627 362	590 331	556 303	526 278	497 256	471 236	447 218	425 202	404 187			
20LH08	19	20	23,200	908 669	873 619	842 575	813 536	785 500	760 468	722 428	687 395	654 365	621 336	588 309	558 285	530 262	503 242	479 225	457 209			
20LH09	21	20	25,400	990 729	953 675	918 626	886 581	856 542	828 507	802 475	778 437	755 399	712 366	673 336	636 309	603 285	572 264	544 244	517 227			
20LH10	23	20	27,400	1068 786	1028 724	991 673	956 626	924 585	894 545	865 510	839 479	814 448	791 411	748 377	707 346	670 320	636 296	604 274	575 254			

			28-32	33	34	35	36	37	38	39	40	41	42	43	44	45	46	47	48
24LH03	11	24	11,500	342 235	339 226	336 218	323 204	307 188	293 175	279 162	267 152	255 141	244 132	234 124	224 116	215 109	207 102	199 96	191 90
24LH04	12	24	14,100	419 288	398 265	379 246	360 227	343 210	327 195	312 182	298 169	285 158	273 148	262 138	251 130	241 122	231 114	222 107	214 101
24LH05	13	24	15,100	449 308	446 297	440 285	419 264	399 244	380 226	363 210	347 196	331 182	317 171	304 160	291 150	280 141	269 132	258 124	248 117
24LH06	16	24	20,300	604 411	579 382	555 356	530 331	504 306	480 284	457 263	437 245	417 228	399 211	381 197	364 184	348 172	334 161	320 152	307 142
24LH07	17	24	22,300	665 452	638 421	613 393	588 367	565 343	541 320	516 297	491 276	468 257	446 239	426 223	407 208	389 195	373 182	357 171	343 161
24LH08	18	24	23,800	707 480	677 447	649 416	622 388	597 362	572 338	545 314	520 292	497 272	475 254	455 238	435 222	417 208	400 196	384 184	369 173
24LH09	21	24	28,000	832 562	808 530	785 501	764 460	731 424	696 393	663 363	632 337	602 313	574 292	548 272	524 254	501 238	480 223	460 209	441 196
24LH10	23	24	29,600	882 596	856 559	832 528	809 500	788 474	768 439	737 406	702 378	668 351	637 326	608 304	582 285	556 266	533 249	511 234	490 220
24LH11	25	24	31,200	927 624	900 588	875 555	851 525	829 498	807 472	787 449	768 418	734 388	701 361	671 337	642 315	616 294	590 276	567 259	544 243
			<b>33-40</b>	<b>41</b>	<b>42</b>	<b>43</b>	<b>44</b>	<b>45</b>	<b>46</b>	<b>47</b>	<b>48</b>	<b>49</b>	<b>50</b>	<b>51</b>	<b>52</b>	<b>53</b>	<b>54</b>	<b>55</b>	<b>56</b>
28LH05	13	28	14,000	337 219	323 205	310 192	297 180	286 169	275 159	265 150	255 142	245 133	237 126	228 119	220 113	213 107	206 102	199 97	193 92
28LH06	16	28	18,600	448 289	429 270	412 253	395 238	379 223	364 209	350 197	337 186	324 175	313 166	301 156	291 148	281 140	271 133	262 126	253 120
28LH07	17	28	21,000	505 326	484 305	464 285	445 267	427 251	410 236	394 222	379 209	365 197	352 186	339 176	327 166	316 158	305 150	295 142	285 135
28LH08	18	28	22,500	540 348	517 325	496 305	475 285	456 268	438 252	420 236	403 222	387 209	371 196	357 185	344 175	331 165	319 156	308 148	297 140
28LH09	21	28	27,700	667 428	639 400	612 375	586 351	563 329	540 309	519 291	499 274	481 258	463 243	446 228	430 216	415 204	401 193	387 183	374 173
28LH10	23	28	30,300	729 466	704 439	679 414	651 388	625 364	600 342	576 322	554 303	533 285	513 269	495 255	477 241	460 228	444 215	429 204	415 193

(Continued)

28LH11	25	28	32,500	780 498	762 475	736 448	711 423	682 397	655 373	629 351	605 331	582 312	561 294	540 278	521 263	502 249	485 236	468 223	453 212
28LH12	27	28	35,700	857 545	837 520	818 496	800 476	782 454	766 435	737 408	709 383	682 361	656 340	632 321	609 303	587 285	566 270	546 256	527 243
28LH13	30	28	37,200	895 569	874 543	854 518	835 495	816 472	799 452	782 433	766 415	751 396	722 373	694 352	668 332	643 314	620 297	598 281	577 266

STANDARD LOAD TABLE—LONGSPAN STEEL JOISTS, LH SERIES—(Continued)

JOIST DESIGNATION	APPROX. WT. IN LBS. PER LINEAR FT. (Joists only)	DEPTH IN INCHES	SAFE LOAD* IN LBS. BETWEEN	CLEAR SPAN IN FEET															
				× 304.8 for mm															
				× 14.59 for N/m	× 25.4 for mm	× 4.448 for N	38-48	49	50	51	52	53	54	55	56	57	58	59	60
32LH06	14	32	16,700	338 211	326 199	315 189	304 179	294 169	284 161	275 153	266 145	257 138	249 131	242 125	234 119	227 114	220 108	214 104	208 99
32LH07	16	32	18,800	379 235	366 223	353 211	341 200	329 189	318 179	308 170	298 162	288 154	279 146	271 140	262 133	254 127	247 121	240 116	233 111
32LH08	17	32	20,400	411 255	397 242	383 229	369 216	357 205	345 194	333 184	322 175	312 167	302 159	293 151	284 144	275 137	267 131	259 125	252 120
32LH09	21	32	25,600	516 319	498 302	480 285	463 270	447 256	432 243	418 230	404 219	391 208	379 198	367 189	356 180	345 172	335 164	325 157	315 149
32LH10	21	32	28,300	571 352	550 332	531 315	512 297	495 282	478 267	462 254	445 240	430 228	416 217	402 206	389 196	376 186	364 178	353 169	342 162
32LH11	24	32	31,000	625 385	602 363	580 343	560 325	541 308	522 292	505 277	488 263	473 251	458 239	443 227	429 216	416 206	403 196	390 187	378 179
32LH12	27	32	36,400	734 450	712 428	688 406	664 384	641 364	619 345	598 327	578 311	559 295	541 281	524 267	508 255	492 243	477 232	463 221	449 211
32LH13	30	32	40,600	817 500	801 480	785 461	771 444	742 420	715 397	690 376	666 354	643 336	621 319	600 304	581 288	562 275	544 262	527 249	511 238
32LH14	33	32	41,800	843 515	826 495	810 476	795 458	780 440	766 417	738 395	713 374	688 355	665 337	643 321	622 304	602 290	583 276	564 264	547 251

32LH15	35	32	43,200	870 532	853 511	837 492	821 473	805 454	791 438	776 422	763 407	750 393	725 374	701 355	678 338	656 322	635 306	616 292	597 279
			<b>42-56</b>	<b>57</b>	<b>58</b>	<b>59</b>	<b>60</b>	<b>61</b>	<b>62</b>	<b>63</b>	<b>64</b>	<b>65</b>	<b>66</b>	<b>67</b>	<b>68</b>	<b>69</b>	<b>70</b>	<b>71</b>	<b>72</b>
36LH07	16	36	16,800	292 177	283 168	274 160	266 153	258 146	251 140	244 134	237 128	230 122	224 117	218 112	212 107	207 103	201 99	196 95	191 91
36LH08	18	36	18,500	321 194	311 185	302 176	293 168	284 160	276 153	268 146	260 140	253 134	246 128	239 123	233 118	227 113	221 109	215 104	209 100
36LH09	21	36	23,700	411 247	398 235	386 224	374 214	363 204	352 195	342 186	333 179	323 171	314 163	306 157	297 150	289 144	282 138	275 133	267 127
36LH10	21	36	26,100	454 273	440 260	426 248	413 236	401 225	389 215	378 206	367 197	357 188	347 180	338 173	328 165	320 159	311 152	303 146	295 140
36LH11	23	36	28,500	495 297	480 283	465 269	451 257	438 246	425 234	412 224	401 214	389 205	378 196	368 188	358 180	348 173	339 166	330 159	322 153
36LH12	25	36	34,100	593 354	575 338	557 322	540 307	523 292	508 279	493 267	478 255	464 243	450 232	437 222	424 213	412 204	400 195	389 187	378 179
36LH13	30	36	40,100	697 415	675 395	654 376	634 359	615 342	596 327	579 312	562 298	546 285	531 273	516 262	502 251	488 240	475 231	463 222	451 213
36LH14	36	36	44,200	768 456	755 434	729 412	706 392	683 373	661 356	641 339	621 323	602 309	584 295	567 283	551 270	535 259	520 247	505 237	492 228
36LH15	36	36	46,600	809 480	795 464	781 448	769 434	744 413	721 394	698 375	677 358	656 342	637 327	618 312	600 299	583 286	567 274	551 263	536 252
			<b>47-64</b>	<b>65</b>	<b>66</b>	<b>67</b>	<b>68</b>	<b>69</b>	<b>70</b>	<b>71</b>	<b>72</b>	<b>73</b>	<b>74</b>	<b>75</b>	<b>76</b>	<b>77</b>	<b>78</b>	<b>79</b>	<b>80</b>
40LH08	16	40	16,600	254 150	247 144	241 138	234 132	228 127	222 122	217 117	211 112	206 108	201 104	196 100	192 97	187 93	183 90	178 86	174 83
40LH09	21	40	21,800	332 196	323 188	315 180	306 173	298 166	291 160	283 153	276 147	269 141	263 136	256 131	250 126	244 122	239 118	233 113	228 109
40LH10	21	40	24,000	367 216	357 207	347 198	338 190	329 183	321 176	313 169	305 162	297 156	290 150	283 144	276 139	269 134	262 129	255 124	249 119
40LH11	22	40	26,200	399 234	388 224	378 215	368 207	358 198	349 190	340 183	332 176	323 169	315 163	308 157	300 151	293 145	286 140	279 135	273 130
40LH12	25	40	31,900	486 285	472 273	459 261	447 251	435 241	424 231	413 222	402 213	392 205	382 197	373 189	364 182	355 176	346 169	338 163	330 157

40LH13	30	40	37,600	573 334	557 320	542 307	528 295	514 283	500 271	487 260	475 250	463 241	451 231	440 223	429 214	419 207	409 199	399 192	390 185
40LH14	35	40	43,000	656 383	638 367	620 351	603 336	587 323	571 309	556 297	542 285	528 273	515 263	502 252	490 243	478 233	466 225	455 216	444 209
40LH15	36	40	48,100	734 427	712 408	691 390	671 373	652 357	633 342	616 328	599 315	583 302	567 290	552 279	538 268	524 258	511 248	498 239	486 230
40LH16	42	40	53,000	808 469	796 455	784 441	772 428	761 416	751 404	730 387	710 371	691 356	673 342	655 329	638 316	622 304	606 292	591 282	576 271

STANDARD LOAD TABLE—LONGSPAN STEEL JOISTS, LH SERIES—(Continued)

JOIST DESIGNATION	APPROX. WT. IN LBS. PER LINEAR FT. (Joists only)	DEPTH IN INCHES	SAFE LOAD* IN LBS. BETWEEN	CLEAR SPAN IN FEET																			
				× 14.59 for N/m	× 25.4 for mm	× 4.448 for N	× 304.8 for mm																
							52-72	73	74	75	76	77	78	79	80	81	82	83	84	85	86	87	88
44LH09	19	44	20,000	272	265	259	253	247	242	236	231	226	221	216	211	207	202	198	194				
				158	152	146	141	136	131	127	122	118	114	110	106	103	99	96	93				
44LH10	21	44	22,100	300	293	286	279	272	266	260	254	249	243	238	233	228	223	218	214				
				174	168	162	155	150	144	139	134	130	125	121	117	113	110	106	103				
44LH11	22	44	23,900	325	317	310	302	295	289	282	276	269	264	258	252	247	242	236	232				
				188	181	175	168	162	157	151	146	140	136	131	127	123	119	115	111				
44LH12	25	44	29,600	402	393	383	374	365	356	347	339	331	323	315	308	300	293	287	280				
				232	224	215	207	200	192	185	179	172	166	160	155	149	144	139	134				
44LH13	30	44	35,100	477	466	454	444	433	423	413	404	395	386	377	369	361	353	346	338				
				275	265	254	246	236	228	220	212	205	198	191	185	179	173	167	161				
44LH14	31	44	40,400	549	534	520	506	493	481	469	457	446	436	425	415	406	396	387	379				
				315	302	291	279	268	259	249	240	231	223	215	207	200	193	187	181				
44LH15	36	44	47,000	639	623	608	593	579	565	551	537	524	512	500	488	476	466	455	445				
				366	352	339	326	314	303	292	281	271	261	252	243	234	227	219	211				
44LH16	42	44	54,200	737	719	701	684	668	652	637	622	608	594	580	568	555	543	531	520				
				421	405	390	375	362	348	336	324	313	302	291	282	272	263	255	246				

(Continued)

44LH17	47	44	58,200	790 450	780 438	769 426	759 415	750 405	732 390	715 376	699 363	683 351	667 338	652 327	638 316	624 305	610 295	597 285	584 276
			<b>56-80</b>	<b>81</b>	<b>82</b>	<b>83</b>	<b>84</b>	<b>85</b>	<b>86</b>	<b>87</b>	<b>88</b>	<b>89</b>	<b>90</b>	<b>91</b>	<b>92</b>	<b>93</b>	<b>94</b>	<b>95</b>	<b>96</b>
48LH10	21	48	20,000	246 141	241 136	236 132	231 127	226 123	221 119	217 116	212 112	208 108	204 105	200 102	196 99	192 96	188 93	185 90	181 87
48LH11	22	48	21,700	266 152	260 147	255 142	249 137	244 133	239 129	234 125	229 120	225 117	220 113	216 110	212 106	208 103	204 100	200 97	196 94
48LH12	25	48	27,400	336 191	329 185	322 179	315 173	308 167	301 161	295 156	289 151	283 147	277 142	272 138	266 133	261 129	256 126	251 122	246 118
48LH13	29	48	32,800	402 228	393 221	384 213	376 206	368 199	360 193	353 187	345 180	338 175	332 170	325 164	318 159	312 154	306 150	300 145	294 141
48LH14	32	48	38,700	475 269	464 260	454 251	444 243	434 234	425 227	416 220	407 212	399 206	390 199	383 193	375 187	367 181	360 176	353 171	346 165
48LH15	36	48	44,500	545 308	533 298	521 287	510 278	499 269	488 260	478 252	468 244	458 236	448 228	439 221	430 214	422 208	413 201	405 195	397 189
48LH16	42	48	51,300	629 355	615 343	601 331	588 320	576 310	563 299	551 289	540 280	528 271	518 263	507 255	497 247	487 239	477 232	468 225	459 218
48LH17	47	48	57,600	706 397	690 383	675 371	660 358	646 346	632 335	619 324	606 314	593 304	581 294	569 285	558 276	547 268	536 260	525 252	515 245

\*The safe uniform load for the clear spans shown in the fourth column is equal to (safe load) ÷ (clear span + 0.67) [For SI: (safe load) ÷ (clear span + 204)]. [The added 0.67 feet (8 inches) (204 mm) is required to obtain the proper length on which the load tables were developed.]

In no case shall the safe uniform load, for clear spans less than the minimum clear span shown in the fourth column, exceed the uniform load calculated for the minimum clear span listed in the fourth column.

To solve for live loads for clear spans shown in the fourth column (or lesser clear spans), multiply the live load of the shortest clear span shown in the load tables by [the shortest clear span shown in the load table + 0.67 feet (204 mm)]<sup>2</sup> and divide by [the actual clear span + 0.67 feet (204 mm)]<sup>2</sup>. The live load shall **not** exceed the safe uniform load.

**STANDARD LOAD TABLE FOR DEEP LONGSPAN STEEL JOISTS, DLH SERIES**  
 Adopted by the Steel Joist Institute May 25, 1983. Revised to November 15, 1989.  
 Based on a Maximum Allowable Tensile Stress of 30,000 psi (207 MPa)

The upper figures in the following table give the **total** safe uniformly distributed load-carrying capacities, in pounds per linear foot (x 14.59 for N/m), of DLH-Series joists. The weight of **dead** loads, including the joists, must in all cases be deducted to determine the **live** load-carrying capacities of the joists. The approximate **dead** load of the joists may be determined from the weights per linear foot (x 14.59 for N/m) shown in the tables. All loads shown are for roof construction only.

The lower figures in this table are the **live** loads per linear foot (x 14.59 for N/m) of joist which will produce an approximate deflection of  $1/360$  of the span. **Live** loads which will produce a deflection of  $1/240$  of the span may be obtained by multiplying the lower figures by 1.5. In no case shall the **total** load capacity of the joists be exceeded.

This load table applies to joists with either parallel chords or standard pitched chords. When top chords are pitched, the carrying capacities are determined by the nominal depth of the joist at the center of the span. Standard top chord pitch is  $1/8$  inch per foot (1:96). If pitch exceeds this standard, the load table does not apply. This load table may be used for parallel chord joists installed to a maximum slope of  $1/2$  inch per foot (1:24).

When holes are required in the top or bottom chords, the carrying capacities must be reduced in proportion to reduction of chord areas.

The top chords are considered as being stayed laterally by the roof deck.

The approximate joist weights per linear foot (x 14.59 for N/m) shown in these tables do **not** include accessories.

JOIST DESIGNATION	APPROX. WT. IN LBS. PER LINEAR FT. (Joists only)	DEPTH IN INCHES	SAFE LOAD* IN LBS. BETWEEN	CLEAR SPAN IN FEET															
				x 14.59 for N/m	x 25.4 for mm	x 4.448 for N	x 304.8 for mm												
							61-88	89	90	91	92	93	94	95	96	97	98	99	100
52DLH10	25	52	26,700	298	291	285	279	273	267	261	256	251	246	241	236	231	227	223	218
				171	165	159	154	150	145	140	136	132	128	124	120	116	114	110	107
52DLH11	26	52	29,300	327	320	313	306	299	293	287	281	275	270	264	259	254	249	244	240
				187	181	174	169	164	158	153	149	144	140	135	132	128	124	120	117
52DLH12	29	52	32,700	365	357	349	342	334	327	320	314	307	301	295	289	284	278	273	268
				204	197	191	185	179	173	168	163	158	153	149	144	140	135	132	128
			<b>61-88</b>	<b>89</b>	<b>90</b>	<b>91</b>	<b>92</b>	<b>93</b>	<b>94</b>	<b>95</b>	<b>96</b>	<b>97</b>	<b>98</b>	<b>99</b>	<b>100</b>	<b>101</b>	<b>102</b>	<b>103</b>	<b>104</b>
52DLH13	34	52	39,700	443	433	424	414	406	397	389	381	373	366	358	351	344	338	331	325
				247	239	231	224	216	209	203	197	191	185	180	174	170	164	159	155
52DLH14	39	52	45,400	507	497	486	476	466	457	447	438	430	421	413	405	397	390	382	375
				276	266	258	249	242	234	227	220	213	207	201	194	189	184	178	173
52DLH15	42	52	51,000	569	557	545	533	522	511	500	490	480	470	461	451	443	434	426	418
				311	301	291	282	272	264	256	247	240	233	226	219	213	207	201	195

52DLH16	45	52	55,000	614 346	601 335	588 324	575 314	563 304	551 294	540 285	528 276	518 267	507 260	497 252	487 245	478 237	468 230	459 224	451 217
52DLH17	52	52	63,300	706 395	691 381	676 369	661 357	647 346	634 335	620 324	608 315	595 304	583 296	572 286	560 279	549 270	539 263	528 255	518 247
			<b>66-96</b>	<b>97</b>	<b>98</b>	<b>99</b>	<b>100</b>	<b>101</b>	<b>102</b>	<b>103</b>	<b>104</b>	<b>105</b>	<b>106</b>	<b>107</b>	<b>108</b>	<b>109</b>	<b>110</b>	<b>111</b>	<b>112</b>
56DLH11	26	56	28,100	288 169	283 163	277 158	272 153	267 149	262 145	257 140	253 136	248 133	244 129	239 125	235 122	231 118	227 115	223 113	219 110
56DLH12	30	56	32,300	331 184	324 178	318 173	312 168	306 163	300 158	295 153	289 150	284 145	278 141	273 137	268 133	263 130	259 126	254 123	249 119
56DLH13	34	56	39,100	401 223	394 216	386 209	379 204	372 197	365 191	358 186	351 181	344 175	338 171	331 166	325 161	319 157	314 152	308 149	303 145
56DLH14	39	56	44,200	453 249	444 242	435 234	427 228	419 221	411 214	403 209	396 202	388 196	381 190	375 186	368 181	361 175	355 171	349 167	343 162
56DLH15	42	56	50,500	518 281	508 272	498 264	488 256	478 248	469 242	460 234	451 228	443 221	434 215	426 209	419 204	411 198	403 192	396 188	389 182
56DLH16	46	56	54,500	559 313	548 304	537 294	526 285	516 277	506 269	496 262	487 254	478 247	469 240	460 233	452 227	444 221	436 214	428 209	420 204
56DLH17	51	56	62,800	643 356	630 345	618 335	605 325	594 316	582 306	571 298	560 289	549 281	539 273	529 266	520 258	510 251	501 245	492 238	483 231
			<b>70-104</b>	<b>105</b>	<b>106</b>	<b>107</b>	<b>108</b>	<b>109</b>	<b>110</b>	<b>111</b>	<b>112</b>	<b>113</b>	<b>114</b>	<b>115</b>	<b>116</b>	<b>117</b>	<b>118</b>	<b>119</b>	<b>120</b>
60DLH12	29	60	31,100	295 168	289 163	284 158	279 154	274 150	270 146	265 142	261 138	256 134	252 131	248 128	244 124	240 121	236 118	232 115	228 113
60DLH13	35	60	37,800	358 203	351 197	345 191	339 187	333 181	327 176	322 171	316 167	311 163	306 158	301 154	296 151	291 147	286 143	282 139	277 135
60DLH14	40	60	42,000	398 216	391 210	383 205	376 199	370 193	363 189	356 183	350 178	344 173	338 170	332 165	327 161	321 156	316 152	310 149	305 145
60DLH15	43	60	49,300	467 255	458 248	450 242	442 235	434 228	427 223	419 216	412 210	405 205	398 200	392 194	385 190	379 185	373 180	367 175	361 171
60DLH16	46	60	54,200	513 285	504 277	494 269	485 262	476 255	468 247	460 241	451 235	444 228	436 223	428 217	421 211	414 206	407 201	400 196	393 190
60DLH17	52	60	62,300	590 324	579 315	569 306	558 298	548 290	538 283	529 275	519 267	510 261	501 254	493 247	484 241	476 235	468 228	460 223	453 217

STANDARD LOAD TABLE FOR DEEP LONGSPAN STEEL JOISTS, DLH SERIES—(Continued)

JOIST DESIGNATION	APPROX. WT. IN LBS. PER LINEAR FT. (Joists only)	DEPTH IN INCHES	SAFE LOAD* IN LBS. BETWEEN	CLEAR SPAN IN FEET																		
				× 14.59 for N/m	× 25.4 for mm	× 4.448 for N	× 304.8 for mm															
							70-104	105	106	107	108	109	110	111	112	113	114	115	116	117	118	119
60DLH18	59	60	71,900	681	668	656	644	632	621	610	599	589	578	568	559	549	540	531	522			
				366	357	346	337	327	319	310	303	294	286	279	272	266	259	252	246			
			<b>75-112</b>	<b>113</b>	<b>114</b>	<b>115</b>	<b>116</b>	<b>117</b>	<b>118</b>	<b>119</b>	<b>120</b>	<b>121</b>	<b>122</b>	<b>123</b>	<b>124</b>	<b>125</b>	<b>126</b>	<b>127</b>	<b>128</b>			
64DLH12	31	64	30,000	264	259	255	251	247	243	239	235	231	228	224	221	218	214	211	208			
				153	150	146	142	138	135	132	129	125	122	119	116	114	111	109	106			
64DLH13	34	64	36,400	321	315	310	305	300	295	291	286	281	277	273	269	264	260	257	253			
				186	181	176	171	168	163	159	155	152	148	144	141	137	134	131	128			
64DLH14	40	64	41,700	367	360	354	349	343	337	332	326	321	316	311	306	301	296	292	287			
				199	193	189	184	179	174	171	166	162	158	154	151	147	143	140	136			
64DLH15	43	64	47,800	421	414	407	400	394	387	381	375	369	363	358	352	347	341	336	331			
				234	228	223	217	211	206	201	196	191	187	182	177	173	170	165	161			
64DLH16	46	64	53,800	474	466	458	450	443	435	428	421	414	407	401	394	388	382	376	370			
				262	254	248	242	235	229	224	218	213	208	203	198	193	189	184	180			
64DLH17	52	64	62,000	546	536	527	518	509	501	492	484	476	468	461	454	446	439	432	426			
				298	290	283	275	268	262	255	248	243	237	231	226	220	215	210	205			
64DLH18	59	64	71,600	630	619	608	598	587	578	568	559	549	540	532	523	515	507	499	491			
				337	328	320	311	304	296	288	282	274	267	261	255	249	243	237	232			
			<b>80-120</b>	<b>121</b>	<b>122</b>	<b>123</b>	<b>124</b>	<b>125</b>	<b>126</b>	<b>127</b>	<b>128</b>	<b>129</b>	<b>130</b>	<b>131</b>	<b>132</b>	<b>133</b>	<b>134</b>	<b>135</b>	<b>136</b>			
68DLH13	37	68	35,000	288	284	279	275	271	267	263	259	255	252	248	244	241	237	234	231			
				171	168	164	159	155	152	149	145	142	138	135	133	130	127	124	121			
68DLH14	40	68	40,300	332	327	322	317	312	308	303	299	294	290	286	281	277	273	269	266			
				184	179	175	171	167	163	159	155	152	148	145	141	138	135	133	130			
68DLH15	40	68	45,200	372	365	360	354	348	343	337	332	327	322	317	312	308	303	299	294			
				206	201	196	191	187	182	178	174	170	166	162	158	155	152	148	145			
68DLH16	49	68	53,600	441	433	427	420	413	407	400	394	388	382	376	371	365	360	354	349			
				242	236	230	225	219	214	209	204	199	195	190	186	182	178	174	171			

68DLH17	55	68	60,400	497 275	489 268	481 262	474 256	467 249	460 244	453 238	446 232	439 228	433 222	427 217	420 212	414 208	408 203	403 198	397 194
68DLH18	61	68	69,900	575 311	566 304	557 297	549 289	540 283	532 276	524 269	516 263	508 257	501 251	493 246	486 240	479 234	472 230	465 225	459 219
68DLH19	67	68	80,500	662 353	651 344	641 336	631 328	621 320	611 313	601 305	592 298	583 291	574 285	565 278	557 272	548 266	540 260	532 254	525 248
			<b>84-128</b>	<b>129</b>	<b>130</b>	<b>131</b>	<b>132</b>	<b>133</b>	<b>134</b>	<b>135</b>	<b>136</b>	<b>137</b>	<b>138</b>	<b>139</b>	<b>140</b>	<b>141</b>	<b>142</b>	<b>143</b>	<b>144</b>
72DLH14	41	72	39,200	303 171	298 167	294 163	290 159	285 155	281 152	277 149	274 146	270 143	266 139	262 136	259 133	255 131	252 128	248 125	245 123
72DLH15	44	72	44,900	347 191	342 187	336 183	331 178	326 174	322 171	317 167	312 163	308 160	303 156	299 152	295 150	291 147	286 143	282 140	279 137
72DLH16	50	72	51,900	401 225	395 219	390 214	384 209	378 205	373 200	368 196	363 191	358 188	353 183	348 179	343 175	338 171	334 169	329 165	325 161
72DLH17	56	72	58,400	451 256	445 250	438 245	432 239	426 233	420 228	414 224	408 218	402 213	397 209	391 205	386 200	381 196	376 191	371 188	366 184
72DLH18	59	72	68,400	528 289	520 283	512 276	505 270	497 265	490 258	483 252	479 247	470 242	463 236	457 231	450 227	444 222	438 217	432 212	426 209
72DLH19	70	72	80,200	619 328	609 321	600 313	591 306	582 300	573 293	565 286	557 280	549 274	541 268	533 263	526 257	518 251	511 247	504 241	497 236

\*This safe uniform load for the clear spans shown in the fourth column is equal to (safe load) ÷ (clear span + 0.67) [For SI: (safe load ÷ (clear span + 204))]. [The added 0.67 feet (8 inches) (204 mm) is required to obtain the proper length on which the load tables were developed.]

In no case shall the safe uniform load, for clear spans less than the minimum clear span shown in the fourth column, exceed the uniform load calculated for the minimum clear span listed in the fourth column.

To solve for live loads for clear spans shown in the fourth column (or lesser clear spans), multiply the live load of the shortest clear span shown in the load tables by [the shortest span shown in the load table + 0.67 feet (204 mm)]<sup>2</sup> and divide by [the actual clear span + 0.67 feet (204 mm)]<sup>2</sup>. The live load shall not exceed the safe uniform load.

$$\frac{L_w}{r} = \frac{L}{r} \sqrt{\frac{1 + 100 \frac{L_h}{L}}{1 + \left(\frac{L_h}{L}\right) \left(\frac{L}{r}\right)^2 \left(\frac{F_{cyw}}{2500}\right)}}$$

For SI:

$$\frac{L_w}{r} = \frac{L}{r} \sqrt{\frac{1 + 100 \frac{L_h}{L}}{1 + \left(\frac{L_h}{L}\right) \left(\frac{L}{r}\right)^2 \left(\frac{4.1 F_{cyw}}{E}\right)}}$$

The above formulas assume that the entire cross section within the length,  $L_h$ , is affected by the heat of welding. If only part of the cross section is so affected, the allowable stress based on  $L_w/r$  shall be substituted for  $F_w$  in the formula in Section 2002.2.

**2012.3 Welding Fabrication.** Welding of aluminum shall be in accordance with approved nationally recognized standards.

### SECTION 2013 — TESTING

**2013.1 General.** Testing shall be considered an acceptable method for substantiating the design of aluminum alloy load-carrying members. Tests shall be conducted by an independent testing laboratory or by a manufacturer's testing laboratory.

**2013.2 Test Loading and Behavior.** In order to test a structure or load-carrying member adequately, the loading shall be applied in a fashion that reasonably approximates the application of the loading during service. Further, the structure or member shall be supported in a manner that is no more sustaining to the structure than the supports available will be when the structure is in service.

Determination of allowable load-carrying capacity shall be made on the basis that the member, assembly or connection shall be capable of sustaining during the test without failure a total load, including the weight of the test specimen, equal to twice the live load plus one and one-half the dead load. Furthermore, harmful local distortions shall not develop during the test at a total load, including the weight of the test specimen, equal to the dead load plus one and one-half times the live load.

The factors by which the design live and dead loads are multiplied to determine the test loads are reduced to three fourths of the values given in the preceding paragraph when wind or seismic forces represent all or a portion of the live load, provided the structure or member meets the test requirements with the full load factors applied to the dead load and to that portion of the live load not attributable to wind or seismic forces.

Differences that may exist between nominal section properties and those of tested sections shall be considered.

## STANDARD SPECIFICATIONS FOR JOIST GIRDERS

Adopted by the Steel Joist Institute May 15, 1978  
Revised to November 12, 1991

### SECTION 1000 SCOPE

These specifications cover the design, manufacture and use of Joist Girders.

### SECTION 1001 DEFINITION

The term "Joist Girders" as used herein, refers to open web, load-carrying members utilizing hot-rolled or cold-formed steel, including cold-formed steel whose yield strength\* has been attained by cold working.

The design of joist girder chord or web sections shall be based on a yield strength of at least 36,000 psi (250 MPa) but not greater than 50,000 psi (345 MPa). Steel used for joist girder chord or web sections shall have a minimum yield strength determined in accordance with one of the procedures specified in Section 1002.2, which is equal to the yield strength assumed in the design. Joist girders shall be designed in accordance with these specifications to support panel point loadings.

### SECTION 1002 MATERIALS

#### 1002.1 STEEL

The steel used in the manufacture of chord and web sections shall conform to one of the following ASTM Specifications of latest adoption:

Standards Specifications and Weight Tables for Joist Girders.

Copyright 1991, Steel Joist Institute

- Structural Steel, ASTM A36/A36M.
- High-Strength Low-Alloy Structural Steel, ASTM A242/A242M.
- High-Strength Low-Alloy Structural Manganese Vanadium Steel, ASTM A441.
- Hot-Rolled Carbon Steel Sheets and Strip, Structural Quality, ASTM A570/A570M.
- High-Strength Low-Alloy Columbium-Vanadium Steel of Structural Quality, ASTM A572/A572M Grades 42, 45 and 50.
- High-Strength Low-Alloy Structural Steel with 50,000 psi (345 MPa) Minimum Yield Point to 4 inches (102 mm) thick, ASTM A588/A588M.
- Steel Sheet and Strip, Hot-Rolled and Cold-Rolled, High-Strength, Low-Alloy, with Improved Corrosion Resistance, ASTM A606.
- Steel Sheet and Strip, Hot-Rolled and Cold-Rolled, High-Strength, Low-Alloy Columbium and/or Vanadium, ASTM A607, Grades 45 and 50.
- Steel, Cold-Rolled Sheet, Carbon Structural, ASTM A611, Grade D.

or shall be of suitable quality ordered or produced to other than the listed specifications, provided that such material in the state used for final assembly and manufacture is weldable and is proved by tests performed by the producer or manufacturer to have the properties specified in Section 1002.2.

---

\*The term "yield strength" as used herein shall designate the yield level of a material as determined by the applicable method outlined in paragraph 13—"Yield Strength," or paragraph 12—"Yield Point," of ASTM A370, "Mechanical Testing of Steel Products," or as specified in Section 1002.2 of this Specification.

### 1002.2 MECHANICAL PROPERTIES

The yield strength used as a basis for the design stresses prescribed in Section 1003 shall be at least 36,000 psi (250 MPa) but shall be not greater than 50,000 psi (345 MPa). Evidence that the steel furnished meets or exceeds the design yield strength shall, if requested, be provided in the form of an affidavit or by witnessed or certified test reports.

For material used without consideration of increase in yield strength resulting from cold forming, the specimens shall be taken from as-rolled material. In the case of material the mechanical properties of which conform to the requirements of one of the listed specifications, test specimens and procedure shall conform to those of such specifications and to ASTM A370.

In the case of material the mechanical properties of which do not conform to the requirements of one of the listed specifications, the test specimens and procedure shall conform to the applicable requirements of ASTM A370 and the specimens shall exhibit a yield strength equal to or exceeding the design yield strength and an elongation of not less than (a) 20 percent in 2 inches (51 mm) for sheet and strip or (b) 18 percent in 8 inches (203 mm) for plates, shapes and bars with adjustments for thickness for plates, shapes and bars as prescribed in ASTM A36/A36M, A242/242M, A441, A572/A572M and A588/A588M whichever specification is applicable on the basis of design yield strength.

The number of tests shall be the same as prescribed in ASTM A6 for plates, shapes and bars; and ASTM A570/A570M, A606, A607 and A611 for sheet and strip.

If as-formed strength is utilized, the test reports shall show the results of tests performed on full section specimens in accordance with the provisions of Sections 3.1.1 and 6.3 of the AISI Specifications for the Design of Cold-Formed Steel Structural Members, and shall indicate compliance with these provisions and with the following additional requirements:

1. The yield strength measured in the tests shall equal or exceed the design yield strength.
2. Where tension tests are made for acceptance and control purposes, the tensile strength shall be at least 6 percent greater than the yield strength of the section.
3. Where compression tests are used for acceptance and control purposes, the specimen shall withstand a gross shortening of 2 percent of its original length without cracking. The length of specimen shall not be greater than 20 times its least radius of gyration.
4. If any test specimen fails to pass the requirements of subparagraphs 1, 2 or 3 above, as applicable, two retests shall be made of specimens from the same lot. Failure of one of the retest specimens to meet such requirements shall be cause for rejection of the lot represented by the specimens.

### 1002.3 WELDING ELECTRODES

The following electrodes shall be used for arc welding:

(a) For connected members both having a specified minimum yield strength greater than 36,000 psi (248 MPa)

AWS A5.1 or A5.5, E70XX

AWS A5.17, F7X, EXXX flux electrode combination

AWS A5.18, E70S-X or E70U-1

AWS A5.20, E70T-X

(b) For connected members both having a specified minimum yield strength of 36,000 psi (248 MPa) or one having a specified minimum yield strength of 36,000 psi (248 MPa) and the other having a specified minimum yield strength greater than 36,000 psi (248 MPa)

AWS A5.1, E60XX

AWS A5.17, F6X-EXXX flux electrode combination

AWS A5.20, E60T-X  
or any of those listed in Section 1002.3 (a).  
Other welding methods, providing equivalent strength as demonstrated by tests, may be used.

**1002.4 PAINT**

The standard shop is a primer coat intended to protect the steel for only a short period of exposure in ordinary atmospheric conditions and shall be considered an impermanent and provisional coating.

The Standard shop paint shall conform to one of the following:

- (a) Steel Structures Painting Council Specification 15-68T, Type I (red oxide).
- (b) Federal Specification TT-P-636 (red oxide).
- (c) Or, shall be a shop paint which meets the minimum performance requirements of one of the above listed specifications.

**SECTION 1003  
DESIGN AND MANUFACTURE**

**1003.1 METHOD**

Joist girders shall be designed in accordance with these specifications as simply supported primary members. All loads will be applied through steel joists, and will be equal in magnitude and evenly spaced along joist girder top chord. Where any applicable design feature is not specifically covered herein, the design shall be in accordance with the following specifications of latest adoption:

- (a) American Institute of Steel Construction Specification for the Design, Fabrication and Erection of Structural Steel for Buildings, where the material used consists of plates, shapes or bars.
- (b) American Iron and Steel Institute Specification for the Design of Cold-formed Steel Structural Members, for members which are cold-formed from sheet or strip material.

**1003.2 UNIT STRESSES**

Joist girders shall have their components so proportioned that the unit stresses in pounds per square inch (MPa) shall not exceed the following where  $F_y$  is the yield strength defined in Section 1002.2:

(a) **Tension:**

All Members .....  $F_t = 0.6F_y$

(b) **Compression:**

For members with  $l/r$  less than  $C_c$ :

$$F_a = \frac{\left[1 - \frac{(l/r)^2}{2C_c^2}\right] QF_y}{\frac{5}{3} + \frac{3}{8} \left(\frac{l/r}{C_c}\right) - \frac{1}{8} \left(\frac{l/r}{C_c}\right)^3} \text{ where } C_c = \sqrt{\frac{2\pi^2 E}{QF_y}} \text{ and}$$

where Q is a form factor equal to unity except when the width-thickness ratio of one or more elements of the profile exceeds the limits specified in AISC Specification, Section B5 (Allowable Stress Design) for hot-rolled sections and in the AISI Specification, Section 3., for cold-formed sections. For members with  $l/r$  greater than  $C_c$ :

$$F_a = \frac{12\pi^2 E}{23(l/r)^2}$$

In the above formula, *l* is the length center-to-center of panel points, and *r* is the corresponding least radius of gyration of the member or any component thereof, both in inches (mm), and *E* is equal to 29,000,000 psi (200 000 MPa).

**(c) Bending:**

- For chords, and for web members other than solid rounds . . . . .  $F_b = 0.6 F_y$
- For web members of solid round cross section . . . . .  $F_b = 0.9 F_y$
- For outstanding legs of top chord angles at points of loading . . . . .  $F_b = 0.75 F_y$
- For bearing plates . . . . .  $F_b = 0.75 F_y$

**(d) Weld Stresses:**

- Shear at throat of fillet welds:
- Made with E70 series electrodes or F7X-EXXX  
flux-electrode combinations . . . . . 21,000 psi (145 MPa)
- Made with E60 series electrodes or F6X-EXXX  
flux-electrode combinations . . . . . 18,000 psi (124 MPa)
- Tension or compression on groove or butt welds shall be the same as those specified for the connected material.

**1003.3 MAXIMUM SLENDERNESS RATIOS**

The slenderness ratio, *l/r*, where *l* is the length center-to-center of support points and *r* is the corresponding least radius of gyration, shall not exceed the following:

- Top chord interior panels . . . . . 90
- Top chord end panels . . . . . 120
- Compression members other than top chord . . . . . 200
- Tension members . . . . . 240

**1003.4 MEMBERS**

**(a) Chords**

The bottom chord shall be designed as an axially loaded tension member. The radius of gyration of the bottom chord about its vertical axis shall be not less than *l*/240 where *l* is the distance between lines of bracing.

The top chord shall be designed as an axially loaded compression member. The radius of gyration of the top chord about the vertical axis shall be not less than *Span*/575.

The top chord shall be considered as stayed laterally by the steel joists, provided positive attachment is made.

**(b) Web**

The vertical shears to be used in the design of the web members shall be determined from full loading but such vertical shear shall be not less than 25 percent of the end reaction.

Interior vertical web members used in modified Warren type web systems that do not support the direct loads through steel joists shall be designed to resist 2 percent of the top chord axial force.

Tension members shall be designed to resist, in compression, at least 25 percent of their axial force.

**(c) Fillers and Ties**

Chord and web members in compression, composed of two components, shall have fillers, ties or welds spaced so that the *l/r* ratio for each component shall not exceed the *l/r* ratio of the whole mem-

ber. Chord and web members in tension, composed of two components, shall have fillers, ties or welds spaced so that the  $l/r$  ratio of each component shall not exceed 240. The least  $r$  shall be used in computing the  $l/r$  ratio of a component.

**(d) Eccentricity**

Members connected at a joint shall have their center of gravity lines meet at a point, if practical. Eccentricity on either side of the centroid of chord members may be neglected when it does not exceed the distance between the centroid and the back of the chord. Otherwise, provision shall be made for the stresses due to eccentricity. Ends of Joist Girders shall be proportioned to resist bending produced by eccentricity at the support. In those cases where a single angle compression member is attached to the outside of the stem of a tee or double angle chord, due consideration shall be given to eccentricity.

**(e) Extended Ends**

Extended top chords or full depth cantilever ends require the special attention of the specifying professional.

The magnitude and location of the design loads to be supported, the deflection requirements and the proper bracing shall be clearly indicated on the structural drawings.

**1003.5 CONNECTIONS**

**(a) Methods**

Joint connections and splices shall be made by attaching the members to one another by arc or resistance welding or other approved method.

**1) Welded Connections**

(a) Selected welds shall be inspected visually by the manufacturer. Prior to this inspection, weld slag shall be removed.

(b) Cracks are not acceptable and shall be repaired.

(c) Thorough fusion shall exist between layers of weld metal and between weld metal and base metal for the required design length of the weld; such fusion shall be verified by visual inspection.

(d) Unfilled weld craters shall not be included in the design length of the weld.

(e) Undercut shall not exceed  $1/16$  inch (2 mm) for welds oriented parallel to the principal stress.

(f) The sum of surface (piping) porosity diameters shall not exceed  $1/16$  inch (2 mm) in any 1 inch (26 mm) of design weld length.

(g) Weld spatter that does not interfere with paint coverage is acceptable.

**2) Welding Program.**

Manufacturers shall have a program for establishing weld procedures and operator qualification, and for weld sampling and testing.

**3) Weld inspection by Outside Agencies (See Section 1004.9 of these specifications).**

The agency shall arrange for visual inspection to determine that welds meet the acceptance standards of Section 1003.5 a.1 above. Ultrasonic X-ray and magnetic particle testing are inappropriate for joists due to the configurations of the components and welds.

**(b) Strength**

Joint connections shall develop the maximum force due to any of the design loads, but not less than 50 percent of allowable strength of the member in tension or compression, whichever force is the controlling factor in the selection of the member.

**(c) Shop Splices**

Shop splices may occur at any point in the chord or web members. Splices shall be designed for the member force but not less than 50 percent of the allowable member strength. Members contain-

ing a butt weld splice shall develop an ultimate tensile force of at least 57,000 psi (393 MPa) times the full design area of the chord or web. The term "member" shall be defined as all component parts, comprising the chord or web, at the point of splice.

**(d) Field Splices**

Field splices shall be designed by the manufacturer and may be either bolted or welded. Splices shall be designed for the member force, but not less than 50 percent of the allowable member strength.

**1003.6 CAMBER**

Joist Girders shall have approximate cambers in accordance with the following:

<b>TOP CHORD LENGTH</b>	<b>APPROXIMATE CAMBER</b>
20'-0" (6096 mm)	1/4" (7 mm)
30'-0" (9144 mm)	3/8" (10 mm)
40'-0" (12 192 mm)	5/8" (16 mm)
50'-0" (15 240 mm)	1" (26 mm)
60'-0" (18 288 mm)	1 1/2" (38 mm)

**1003.7 SHOP PAINTING**

Joist girders and accessories shall receive one shop coat of protective paint as specified in Section 1002.4.

**1003.8 VERIFICATION OF DESIGN AND MANUFACTURE**

**(a) Design Calculations**

Companies manufacturing Joist Girders shall submit design data to the Steel Joist Institute (or an independent agency approved by the Steel Joist Institute) for verification of compliance with the SJI Specifications.

**(b) In-Plant Inspections**

Each manufacturer shall verify their ability to manufacture Joist Girders through periodic In-Plant Inspections. Inspections shall be performed by an independent agency approved by the Steel Joist Institute. The frequency, manner of inspection and manner of reporting shall be determined by the Steel Joist Institute. The In-Plant Inspections are not a guarantee of the quality of any specific Joist Girders; this responsibility lies fully and solely with the individual manufacturer.

**SECTION 1004  
APPLICATION**

**1004.1 USAGE**

These specifications shall apply to any type of structure where steel joists are to be supported directly by Joist Girders installed as hereinafter specified. Where Joist Girders are used other than on simple spans under equal concentrated gravity loading, as prescribed in Section 1003.1, they shall be investigated and modified if necessary to limit the unit stresses to those listed in Section 1003.2. The magnitude and location of all loads and forces, other than equal concentrated gravity loadings, shall be provided on the structural drawings. The specifying professional shall design the supporting structure, including the design of columns, connections and moment plates. This design shall account for the stresses caused by lateral forces and the stresses due to connecting the bottom chord to the column or other support.

The designed detail of a rigid type connection and moment plates shall be shown on the structural drawings. The moment plates shall be furnished by other than the joist manufacturer.

## 1004.2 DEPTH

The nominal depth of sloping chord Joist Girders shall be the depth at mid-span.

## 1004.3 END SUPPORTS

### (a) Masonry and Concrete

Joist Girders supported by masonry or concrete are to bear on steel bearing plates and shall be designed as steel bearing. Due consideration of the end reactions and all other vertical or lateral forces shall be taken by the specifying professional in the design of the steel bearing plate and the masonry or concrete. The ends of the Joist Girders shall extend a distance of not less than 6 inches (152 mm) over the masonry or concrete support and be anchored to the steel bearing plate. The plate shall be located not more than  $\frac{1}{2}$  inch (13 mm) from the face of the wall and shall be not less than 9 inches (229 mm) wide perpendicular to the length of the girders. It is to be designed by the specifying professional in compliance with the allowable unit stresses in Section A5.1 (Allowable Stress Design) of the A.I.S.C. Specifications of latest adoption. The steel bearing plate shall be furnished by other than the joist manufacturer.

Where it is deemed necessary to bear less than 6 inches (152 mm) over the masonry or concrete support, special consideration is to be given to the design of the steel bearing plate and the masonry or concrete by the specifying professional. The girders must bear a minimum of 4 inches (102 mm) on the steel bearing plate.

### (b) Steel

Due consideration of the end reactions and all other vertical and lateral forces shall be taken by the specifying professional in the design of the steel support. The ends of Joist Girders shall extend a distance of not less than 4 inches (102 mm) over the steel supports and shall have positive attachment to the support, either by bolting or welding.

## 1004.4 BRACING

Joist Girders shall be proportioned such that they can be erected without bridging (See Section 1004.8 for bracing required for uplift forces). Therefore, the following requirements must be met:

(a) The ends of the bottom chord are restrained from lateral movement to brace the girder from overturning.

(b) No other loads shall be placed on the Joist Girder until the steel joists bearing on the girder are in place and welded to the girder.

## 1004.5 END ANCHORAGE

### (a) Masonry and Concrete

Ends of Joist Girders resting on steel bearing plates on masonry or structural concrete shall be attached thereto with a minimum of two  $\frac{1}{4}$  inch (6 mm) fillet welds 2 inches (51 mm) long, or with two  $\frac{3}{4}$  inch (20 mm) bolts.

### (b) Steel

Ends of Joist Girders resting on steel supports shall be attached thereto with a minimum of two  $\frac{1}{4}$  inch (6 mm) fillet welds 2 inches (51 mm) long, or with two  $\frac{3}{4}$  inch (20 mm) bolts. In steel frames, Joist Girders at column lines shall be field bolted to the columns to provide lateral stability during construction.

### (c) Uplift

Where uplift forces are a design consideration, roof Joist Girders shall be anchored to resist such forces.

## 1004.6 DEFLECTION

The deflection due to the design live load shall not exceed the following:

<b>Floors:</b>	$\frac{1}{360}$ of span.
<b>Roofs:</b>	$\frac{1}{360}$ of span where a plaster ceiling is attached or suspended.
	$\frac{1}{240}$ of span for all other cases.

The Specifying Professional shall give due consideration to the effects of deflection in selection of Joist Girders.

#### 1004.7 PONDING

Unless a roof surface is provided with sufficient slope toward points of free drainage or adequate individual drains to prevent the accumulation of rain water, the roof system shall be investigated to assure stability under ponding conditions in accordance with Section K2 (Allowable Stress Design) of the AISC Specifications.\*

The ponding investigation shall be performed by the specifying professional.

#### 1004.8 UPLIFT

Where uplift forces due to wind are a design requirement, these forces must be indicated on the contract drawings in terms of net uplift in pounds per square foot (Pa). When these forces are specified, they must be considered in the design of the Joist Girders and/or bracing. If the ends of the bottom chord are not strutted, bracing must be provided near the first bottom chord panel points whenever uplift due to wind forces is a design consideration.\*\*

#### 1004.9 INSPECTION

Joist Girders shall be inspected by the manufacturer before shipment to insure compliance of materials and workmanship with the requirements of these specifications. If the purchaser wishes an inspection of the Joist Girders by someone other than the manufacturer's own inspectors, he may reserve the right to do so in his "Invitation to Bid" or the accompanying "Job Specifications". Arrangements shall be made with the manufacturer for such inspection of the Joist Girders at the manufacturing shop by the purchaser's inspectors at purchaser's expense.

### SECTION 1005\*\*\* HANDLING AND ERECTION

Particular attention should be paid to the erection of Joist Girders.

Care shall be exercised at all times to avoid damage through careless handling during unloading, storing and erecting. Dropping of Joist Girders shall not be permitted.

During the construction period, the contractor shall provide means for the adequate distribution of concentrated loads so that the carrying capacity of any Joist Girder is not exceeded.

Field welding shall not damage the Joist Girder. The total length of weld at any one cross-section on cold-formed members whose yield strength has been attained by cold working, and whose as-formed strength is used in the design, shall not exceed 50 percent of the overall developed width of the cold-formed section.

---

\*For further reference, refer to Steel Joist Institute Technical Digest #3 "Structural Design of Steel Joist Roofs to Resist Ponding Loads".

\*\*For future reference, refer to Steel Joist Institute Technical Digest #6 "Structural Design of Steel Roofs to Resist Uplift Loads".

\*\*\*For thorough coverage of this topic, refer to SJI Technical Digest #9, "Handling and Erection of Steel Joists and Joist Girders" (See page 5).

**JOIST GIRDERS  
DESIGN GUIDE WEIGHT TABLE FOR JOIST GIRDERS**

Based on Allowable Tensile Stress of 30,000 psi (207 MPa)  
Joist Girder Weight—Pounds Per Linear Foot ( × 14.59 for N/m)

SPAN	NO. OF JOIST SPACES	PANEL PT. LOAD	4K	5K	6K	7K	8K	9K	10K	11K	12K	13K	14K	15K	16K	17K	18K	19K	20K
		x 4.448 for kN																	
		Depth in inches																	
x 304.8 for mm		x 25.4 for mm																	
20' 0"	3N@6.67'	20	13	13	14	16	17	20	22	23	25	27	29	30	31	34	36	39	40
		24	13	14	14	14	15	17	19	21	22	24	25	25	29	29	30	32	33
		28	13	14	14	14	15	17	17	17	21	22	23	24	24	26	27	30	31
	4N@5.0'	20	14	14	15	17	18	21	23	24	26	28	31	33	34	37	38	41	43
		24	14	15	15	15	16	18	20	22	23	25	27	28	32	32	32	34	35
		28	14	15	15	15	16	18	18	18	22	23	25	26	26	28	29	32	33
22' 0"	4N@5.5'	20	17	17	17	18	20	23	24	27	28	30	33	34	39	40	43	46	46
		24	17	17	17	17	18	19	21	23	24	27	29	29	33	34	34	40	40
		28	17	17	17	17	17	18	19	20	21	24	25	27	28	29	30	34	35
24' 0"	4N@6.0'	20	15	15	17	19	22	24	26	29	32	34	36	37	41	45	46	49	51
		24	15	15	15	17	19	21	23	25	27	30	31	33	34	37	38	40	43
		28	15	15	15	16	17	18	21	24	24	26	28	29	31	33	34	35	37
		32	15	15	15	16	16	19	19	22	22	25	25	27	29	30	31	31	34
	5N@4.8'	20	17	18	18	23	26	28	29	33	39	39	42	45	49	52	52	56	60
		24	17	17	18	19	20	24	26	29	30	34	34	40	40	43	47	47	50
25' 0"	4N@6.25'	20	16	16	18	20	22	25	27	31	32	35	37	39	42	44	46	48	52
		24	15	15	17	17	20	22	24	26	27	30	32	34	35	38	40	42	45
		28	15	15	15	16	18	20	22	23	26	28	28	31	33	34	35	37	39
		32	15	15	16	16	17	19	20	22	24	25	27	28	29	31	33	34	35
	5N@5.0'	20	18	18	22	25	27	31	33	36	40	43	45	48	52	55	57	60	63
		24	16	16	19	21	24	26	29	32	34	37	40	41	44	47	50	53	55
		28	15	15	17	19	21	24	27	28	31	33	34	38	39	42	44	46	48
		32	15	15	16	16	19	20	22	24	26	28	29	32	34	34	37	40	42

26' 0"	4N@6.5'	20	16	16	19	22	24	26	29	32	33	37	39	42	44	47	50	52	53
		24	15	15	16	19	21	22	25	27	30	32	33	35	38	40	41	43	45
		28	15	15	15	17	18	20	23	24	27	28	30	33	33	35	36	38	40
	32	15	15	16	16	17	18	20	23	23	24	26	27	28	31	33	34	35	36
	5N@5.20'	20	19	19	21	25	28	31	36	39	42	43	48	50	55	58	61	65	68
		24	16	16	19	22	26	27	31	32	35	38	41	42	46	48	50	53	56
28		15	15	17	19	21	24	27	29	32	33	36	38	40	43	45	47	49	
32	15	15	17	19	20	23	24	28	28	31	33	34	36	38	40	43	45	45	
28' 0"	4N@7.0'	20	17	17	20	22	25	29	31	34	37	39	44	44	47	50	52	55	58
		24	16	16	17	21	22	25	26	29	32	33	35	38	41	43	44	47	49
		28	15	15	17	17	20	22	24	27	27	30	33	33	36	37	39	42	45
		32	15	15	15	17	18	20	22	24	25	27	28	31	33	34	34	37	40
	36	16	16	16	16	18	19	20	23	24	25	29	29	29	31	33	34	35	
	5N@5.6'	20	20	20	24	27	30	36	39	42	44	48	52	55	59	62	65	67	70
		24	18	18	21	23	26	29	32	36	37	41	42	46	49	53	56	58	60
		28	17	17	19	21	23	26	29	31	33	37	37	40	43	45	47	49	51
		32	16	16	17	19	22	24	27	28	30	33	34	38	38	41	44	46	48
36	16	16	16	19	20	23	25	27	28	31	33	33	36	38	41	42	43		
6N@4.67'	20	20	23	26	29	35	38	44	47	51	55	58	64	68	73	76			
	24	18	19	23	26	29	33	36	39	42	45	52	52	56	59	63	66	74	
	28	17	18	20	23	27	29	30	34	39	40	43	47	50	53	57	58	61	
	32	17	18	19	20	24	27	29	31	35	35	41	41	45	49	49	52	55	
36	18	18	19	19	22	25	26	30	32	32	37	39	43	44	47	50	50		
30' 0"	5N@6.0'	24	18	19	22	25	28	31	34	37	39	42	45	48	52	55	58	61	
		28	17	17	19	22	26	28	31	32	36	37	40	43	46	48	50	54	57
		32	17	17	17	21	22	25	28	30	32	34	37	38	41	43	45	48	51
		36	16	16	18	20	22	23	27	28	31	33	33	35	39	40	42	44	46
	40	16	16	17	18	20	24	24	27	29	30	31	34	35	38	41	42	44	
	6N@5.0'	24	17	20	23	28	32	35	38	41	45	51	52	58	59	65			
		28	17	18	20	24	27	30	34	39	39	43	46	49	53	56	60	61	
		32	17	18	19	21	25	28	29	33	35	40	40	44	48	50	54	55	58
36		18	18	19	20	24	26	29	30	32	35	38	42	43	46	49	49	55	
40	18	18	19	20	21	25	27	30	32	33	36	38	43	44	45	47	50		

(Continued)

**JOIST GIRDERS  
DESIGN GUIDE WEIGHT TABLE FOR JOIST GIRDERS—(Continued)**

Based on Allowable Tensile Stress of 30,000 psi (207 MPa)  
Joist Girder Weight—Pounds Per Linear Foot (× 14.59 for N/m)

SPAN	NO. OF JOIST SPACES	PANEL PT. LOAD	4K	5K	6K	7K	8K	9K	10K	11K	12K	13K	14K	15K	16K	17K	18K	19K	20K
		× 4.448 for kN																	
		Depth in Inches																	
		× 304.8 for mm																	
32' 0"	5N@6.4'	24	20	20	24	25	30	33	36	39	42	45	48	52	55	59	63	67	70
		28	18	18	21	24	26	30	31	36	37	40	43	46	49	51	54	57	60
		32	17	17	19	21	24	27	30	32	34	36	37	41	43	46	49	52	54
		36	16	16	18	20	22	26	28	30	33	33	35	38	39	42	45	47	49
		40	16	16	18	19	22	24	26	28	28	30	32	33	35	39	41	43	44
	6N@5.33'	24	22	22	26	30	34	37	42	45	48	52	55	59	63	67	64	67	69
		28	20	20	22	26	30	33	37	40	43	46	49	52	56	60	64	67	69
		32	19	19	21	24	27	30	33	36	39	42	45	47	51	53	56	58	61
		36	18	18	20	24	26	29	32	34	37	38	40	43	48	50	51	55	58
		40	17	17	19	22	25	28	29	32	35	35	39	41	43	46	49	51	53
34' 0"	5N@6.8'	24	20	20	25	29	30	36	39	42	45	48	52	55	61	64	68	71	74
		28	20	20	21	24	28	31	33	37	39	42	46	49	49	52	56	60	64
		32	17	17	20	21	26	28	31	34	36	37	42	43	47	49	50	54	57
		36	17	17	19	21	24	26	29	31	32	35	38	40	43	45	48	50	52
		40	16	16	18	20	23	26	27	29	32	33	35	38	39	41	44	47	49
	6N@5.67'	24	24	24	27	31	36	40	43	48	51	55	59	63	70	74	78	84	71
		28	22	22	25	28	32	36	39	42	44	49	52	56	58	62	65	68	71
		32	19	19	23	27	29	33	35	37	41	45	46	51	51	56	60	63	65
		36	18	18	21	24	27	30	32	34	38	39	43	46	49	51	53	56	59
		40	18	18	20	23	25	28	31	33	34	37	41	42	46	49	52	54	55
35' 0"	5N@7.0'	28	20	20	23	25	29	31	35	38	41	43	47	49	53	57	60	62	64
		32	18	18	20	23	27	29	32	33	37	39	42	44	47	49	52	54	57
		36	17	17	19	21	25	27	30	32	32	37	38	41	44	46	48	50	52
		40	17	17	18	22	22	27	28	30	32	33	35	38	39	42	45	47	49
		28	22	22	25	29	32	36	39	44	46	49	52	56	60	64	68	74	79
	6N@5.83'	32	20	20	23	26	30	33	37	38	41	45	48	51	53	57	60	63	66
		36	19	19	22	25	28	31	34	35	38	41	44	46	50	53	55	58	61
		40	18	18	20	24	26	28	32	34	36	39	40	44	48	50	52	54	57

35' 0" (cont.)	7N@5.0'	28	25	25	29	32	37	42	45	50	54	58	63	68						
		32	22	22	26	30	33	37	42	45	48	51	57	59	65					
		36	21	21	25	28	31	34	38	41	45	48	52	55	59	63				
		40	21	21	23	27	30	33	35	40	43	45	48	52	54	58	61	63	66	
36' 0"	6N@6.0'	28	22	22	25	30	35	36	41	44	48	50	55	58	64	67	70	74	78	
		32	21	21	23	27	32	33	37	40	43	46	50	51	57	60	63	66	69	
		36	19	19	22	25	28	32	34	38	39	42	46	48	52	55	57	60	62	
		40	18	18	21	24	28	29	32	34	37	39	42	45	48	51	53	56	58	
	7N@5.14'	44	19	19	21	23	26	29	31	33	35	38	41	45	47	49	52	54	54	
		28	25	25	30	34	39	42	47	50	55	59	63	70	78					
		32	22	22	26	31	34	39	43	46	50	53	57	61	65	69	72			
		36	22	22	25	29	32	35	38	43	46	49	53	57	59	63	66	70	74	
38' 0"	6N@6.33'	40	21	21	25	28	31	33	37	40	42	46	50	53	55	59	62	65	68	
		44	19	19	22	26	28	30	33	35	39	42	45	47	49	52	55	58	61	
		44	19	19	21	23	26	28	31	34	36	40	41	44	47	49	52	55	57	
		28	24	24	28	31	36	40	45	48	55	58	63	70	71					
	7N@5.43'	32	24	24	28	32	37	40	44	49	53	56	60	64	69	74				
		36	22	22	27	30	33	38	41	44	48	51	54	58	62	67	71	76	80	
		40	21	21	25	28	32	34	39	42	45	47	53	54	58	61	63	68	72	
		44	21	21	28	28	30	34	35	41	41	46	49	51	54	58	61	63	65	
40' 0"	6N@6.67'	28	25	25	29	32	36	42	45	48	52	55	61	63	68	73				
		32	22	22	25	31	33	37	39	43	46	49	55	56	62	66	69			
		36	21	21	24	27	32	34	37	40	44	47	50	51	57	60	63	68	72	
		40	20	20	22	26	30	32	34	38	41	44	46	48	52	55	58	60	62	
	7N@5.71'	44	19	19	23	25	28	31	34	35	39	40	43	45	50	51	53	56	60	
		28	27	27	32	38	42	48	51	57	62	67	70							
		32	25	25	30	34	37	42	46	49	56	58	64	69	71	75				
		36	23	23	27	32	35	38	43	47	51	53	58	61	66	69	72	76	80	
40	23	23	26	30	33	36	39	43	47	50	52	57	59	63	66	71	75			
44	21	21	25	29	31	34	37	40	43	47	50	53	57	60	63	66	69	69		

(Continued)

**JOIST GIRDERS  
DESIGN GUIDE WEIGHT TABLE FOR JOIST GIRDERS—(Continued)**

Based on Allowable Tensile Stress of 30,000 psi (207 MPa)  
Joist Girder Weight—Pounds Per Linear Foot (× 14.59 for N/m)

SPAN	NO. OF JOIST SPACES	PANEL PT. LOAD	4K	5K	6K	7K	8K	9K	10K	11K	12K	13K	14K	15K	16K	17K	18K	19K	20K		
		× 4.448 for kN																			
		Depth in inches																			
× 304.8 for mm		× 25.4 for mm																			
40' 0" (cont.)	8N@5.0'	28	31	31	36	42	47	51	57	62	70										
		32	28	28	32	37	43	46	51	56	60	66	71								
		36	26	26	30	34	39	43	48	51	56	60	66	68	73	77					
		40	24	24	28	33	36	40	44	48	52	56	60	63	67	71	75	79			
		44	23	23	29	32	36	39	42	45	49	53	55	59	63	67	70	75	79		
42' 0"	6N@7.0'	32	24	24	28	31	36	39	42	46	49	53	56	62	64	68	71	75			
		36	21	21	25	29	32	37	37	43	45	48	50	55	57	61	65	69	72		
		40	21	21	23	27	30	32	38	38	43	44	48	52	54	56	58	62	66		
		44	20	20	23	27	28	32	33	38	39	42	45	48	51	54	56	59	62	66	
		48	19	19	22	24	27	30	34	36	37	40	43	46	48	51	54	56	59	62	66
	52	20	20	22	24	27	31	33	35	36	38	41	44	47	50	52	54	55			
	7N@6.0'	32	25	25	30	36	39	44	48	52	56	63	68	71							
		36	25	25	29	33	37	40	43	47	51	57	61	65	70						
		40	22	22	28	30	33	38	41	44	48	52	55	59	62	67	71	76	81		
		44	23	23	26	28	33	36	39	43	46	49	53	56	59	63	66	70	73		
		48	21	21	24	29	32	35	37	41	43	47	49	54	55	59	62	65	68		
	52	22	22	25	28	31	33	36	38	42	45	48	50	53	57	60	62	64			
	8N@5.25'	32	23	28	33	38	45	48	51	58	62	66	73	77	82	90	93	98			
		36	21	26	29	34	39	42	46	53	56	60	67	67	75	79	86	91	97		
		40	20	24	28	31	35	40	44	47	54	55	61	62	68	69	76	81	88		
44		19	22	26	30	34	36	41	45	49	52	56	60	63	67	70	78	78			
48		19	21	26	30	32	36	39	43	47	51	54	57	61	64	65	72	73			
52	20	21	24	28	31	34	39	42	45	49	52	53	59	59	63	67	71				

44' 0"	7N@6.29'	32	28	28	32	36	42	45	49	55	61	63	70	78	78	85	80	86	81
		36	26	26	30	33	37	43	46	50	53	57	63	65	71	76	73	77	75
		40	24	24	27	32	35	38	44	47	51	54	58	61	66	69	67	71	69
		44	23	23	27	31	33	38	39	45	47	51	52	57	59	63	65	67	69
		48	23	23	26	29	32	35	39	41	45	47	50	54	57	61	65	67	69
	52	22	22	25	29	31	36	37	42	43	46	48	52	56	59	62	64	64	66
	8N@5.5'	32	30	30	36	41	46	50	55	63	68	71	78	83	79	86			
		36	28	28	33	37	42	46	50	57	60	65	70	72	79	86			
		40	27	27	31	34	38	44	48	51	55	60	66	68	73	77	81	88	83
		44	24	24	29	34	37	41	46	50	53	56	60	64	68	72	76	80	79
		48	24	24	30	32	36	40	42	47	49	54	56	62	64	67	70	75	75
	52	24	24	27	31	35	38	42	45	49	51	56	58	62	65	67	71	74	74
	9N@4.89'	32	27	32	38	45	48	54	58	65	72	77	75	79					
		36	24	29	34	40	46	49	53	60	67	67	75	79					
		40	21	28	31	35	41	47	50	54	61	65	69	76	76	81	86		
44		20	26	30	35	38	42	49	52	56	60	63	70	71	77	82	86	85	
48		20	25	29	32	37	42	44	51	53	58	61	65	69	72	80	81	85	
52	21	24	28	32	35	39	45	49	52	55	59	63	67	67	74	75	82	82	
45' 0"	7N@6.43'	32	22	27	31	35	38	44	51	52	58	64	65	72	73	86			
		36	19	24	28	32	38	39	45	45	52	58	59	66	66	74	74		
		40	19	23	27	29	33	39	40	46	47	53	53	60	61	67	67	75	76
		44	19	20	24	28	30	35	40	41	47	47	53	54	61	61	62	68	69
		48	18	20	24	25	30	34	36	41	42	48	49	50	55	56	62	63	70
	52	19	20	22	25	29	31	35	37	42	43	49	50	50	56	57	64	64	
	56	19	20	22	25	27	31	33	36	39	44	45	48	51	51	58	58	59	
	8N@5.63'	32	30	30	36	42	46	52	63	68	78	78	79	80					
		36	29	29	33	37	43	46	51	57	60	65	72	79	80				
		40	27	27	32	36	39	44	48	52	58	60	66	71	73	76	82		
44		25	25	30	33	39	42	46	49	53	56	62	66	68	71	76	80	83	
48		25	25	30	33	36	41	44	47	51	54	57	62	65	67	74	78	84	
52	25	25	28	31	36	39	43	45	48	52	56	59	63	65	71	74	77		
56	24	24	28	32	35	38	41	44	47	51	54	58	59	62	67	71	74	74	

(Continued)

**JOIST GIRDERS  
DESIGN GUIDE WEIGHT TABLE FOR JOIST GIRDERS—(Continued)**

Based on Allowable Tensile Stress of 30,000 psi (207 MPa)  
Joist Girder Weight—Pounds Per Linear Foot (× 14.59 for N/m)

SPAN	NO. OF JOIST SPACES	PANEL PT. LOAD	4K	5K	6K	7K	8K	9K	10K	11K	12K	13K	14K	15K	16K	17K	18K	19K	20K	
		x 4.448 for kN																		
		Depth in Inches																		
x 304.8 for mm		x 25.4 for mm																		
45' 0" (cont.)	9N@5.0'	32	34	34	41	47	52	58	63	70	78	83								
		36	31	31	37	43	48	53	58	64	72	79	80							
		40	29	29	34	40	44	49	53	58	64	68	74	81	86					
		44	28	28	34	38	42	48	51	54	60	64	69	76	79	84	88			
		48	28	28	33	36	42	44	50	53	56	62	64	71	76	81	85	88		
		52	28	28	31	35	39	43	48	51	55	58	63	66	72	76	80	85	89	
56	27	27	32	35	40	43	46	50	53	55	57	60	64	68	72	75	80	84		
46' 0"	7N@6.57'	32	29	29	33	39	42	48	52	57	63	68	70	78	82					
		36	26	26	31	36	40	43	48	53	56	62	64	69	75	80	84			
		40	25	25	29	32	38	41	44	49	51	56	59	63	69	73	77	79	81	
		44	23	23	28	32	35	39	42	45	49	52	55	59	65	68	72	76	79	81
		48	23	23	27	30	34	36	40	43	46	49	53	56	60	63	66	69	73	79
		52	22	22	24	30	33	35	37	41	44	47	51	55	56	59	62	66	69	73
	56	22	22	25	29	32	35	36	41	43	43	45	49	53	55	58	60	63	66	
	8N@5.75'	32	31	31	37	42	48	52	57	63	70	78	82							
		36	28	28	34	38	43	49	53	57	64	69	72	79	84					
		40	27	27	32	35	41	44	49	52	58	62	66	71	73	79	86			
		44	26	26	30	34	39	42	48	51	54	59	62	67	72	77	82	84	87	
		48	25	25	29	33	36	41	44	48	52	55	59	63	67	71	74	79	84	87
		52	25	25	30	33	36	39	42	46	50	52	56	59	63	67	70	75	79	84
	56	25	25	28	32	36	38	43	45	48	52	54	58	61	63	66	70	74	79	
	9N@5.11'	32	27	33	38	45	51	58	62	68	73									
		36	24	30	34	39	45	52	56	60	66	74	79							
		40	24	28	33	40	43	47	53	57	61	68	71	76	80					
		44	22	26	30	36	41	44	49	55	59	63	66	70	77	78	82			
48		21	25	30	33	37	42	47	50	57	57	64	65	71	72	80	84			
52		21	23	30	32	36	40	45	48	52	58	59	66	66	73	74	81	81		
56	21	23	28	32	35	40	46	47	52	54	60	61	65	69	72	75	76			

48' 0"	7N@6.86'	32	30	30	35	40	45	48	55	61	66	70	77	78						
		36	28	28	31	37	41	46	49	54	59	64	68	71	79	85				
		40	25	25	30	33	38	42	47	50	53	57	63	65	70	75	80			
		44	25	25	29	33	37	39	43	47	51	54	58	62	66	70	74	79	81	
		48	23	23	27	31	34	38	41	45	49	51	53	58	60	64	68	72	75	
		52	23	23	27	30	33	37	39	43	46	50	52	54	59	62	65	69	72	
	56	23	23	25	29	33	35	38	42	44	48	51	54	56	60	63	67	69		
	60	22	22	25	30	32	35	36	39	44	46	49	50	55	58	61	62	84		
	8N@6.0'	32	32	32	39	44	48	55	61	68	70	78								
		36	30	30	36	40	45	49	56	60	64	71	78	79						
		40	28	28	33	38	42	47	51	54	59	65	70	72	80					
		44	27	27	32	35	39	45	49	52	55	59	65	67	74	78	82			
		48	26	26	30	34	37	41	47	50	53	56	60	65	68	72	76	80	84	
		52	26	26	30	33	36	42	44	48	51	55	59	62	65	68	71	76	80	
	56	25	25	28	33	36	39	43	46	49	53	57	60	63	66	69	74	78		
	60	24	24	29	33	35	37	41	45	48	51	55	58	59	64	68	72	75		
	9N@5.33'	32	36	36	44	48	55	62	69	77	82									
		36	32	32	40	45	50	56	64	69	72	79								
40		31	31	38	41	47	52	57	62	67	73	80	85							
44		30	30	35	39	45	49	54	59	63	67	75	82	83						
48		30	30	34	37	42	47	51	55	60	63	69	74	77	81	85				
52		28	28	33	37	42	45	49	53	57	63	65	71	73	80	86	89	92		
56	28	28	32	36	40	44	48	52	56	59	63	67	73	77	81	85	89			
60	27	27	33	36	39	42	46	50	54	57	60	65	69	73	76	80	84			
50' 0"	8N@6.25'	32	34	34	39	45	51	57	62	69	77	82								
		36	31	31	37	43	46	52	56	63	68	71	78	83	91					
		40	29	29	34	38	43	47	54	57	63	65	72	79	80					
		44	27	27	33	37	41	45	49	53	58	62	66	71	74	78	82	88		
		48	27	27	31	35	40	43	46	51	54	59	64	68	72	77	83	85	88	
		52	26	26	29	35	38	41	44	49	54	56	61	64	67	71	75	80	85	
56	25	25	30	33	36	41	43	48	51	56	57	62	63	68	72	76	80			
60	25	25	29	33	37	39	44	47	50	52	57	58	61	65	69	72	75			

(Continued)

**JOIST GIRDERS  
DESIGN GUIDE WEIGHT TABLE FOR JOIST GIRDERS—(Continued)**

Based on Allowable Tensile Stress of 30,000 psi (207 MPa)  
Joist Girder Weight—Pounds Per Linear Foot ( × 14.59 for N/m)

SPAN	NO. OF JOIST SPACES	PANEL PT. LOAD	4K	5K	6K	7K	8K	9K	10K	11K	12K	13K	14K	15K	16K	17K	18K	19K	20K		
		× 4.448 for kN																			
		Depth in Inches																			
× 304.8 for mm		× 25.4 for mm																			
50' 0" (cont.)	9N@5.56'	32	38	38	44	51	57	62	69	78											
		36	34	34	40	46	52	58	63	71	78	83									
		40	32	32	38	44	49	54	59	65	70	80	80								
		44	31	31	35	41	45	52	55	61	66	72	74	82	86	92	97				
		48	29	29	34	40	43	48	54	57	61	68	70	76	83	86	89	95			
		52	30	30	33	37	42	47	50	55	58	63	68	71	78	82	86	93			
	56	28	28	33	37	40	46	49	53	57	60	64	68	72	77	81	85	89			
	60	28	28	32	37	40	45	47	51	55	59	62	66	70	75	80	84	88			
	10N@5.0'	32	44	44	51	61	68	76													
		36	42	42	47	55	62	68	77	80											
		40	37	37	44	49	56	63	69	79	81										
		44	35	35	41	46	52	57	65	70	75	82									
48		34	34	39	44	50	55	60	66	72	76	83	85								
52		33	33	37	43	48	52	56	61	68	73	75	82	86	92						
56	33	33	37	41	46	49	54	58	64	69	74	76	83	89	95	98	100				
60	33	33	35	39	46	47	53	56	62	65	70	76	77	83	88	95	102				
52' 0"	8N@6.5'	36	32	32	37	42	49	54	59	63	70										
		40	30	30	35	40	45	50	55	60	64	69	76								
		44	29	29	33	38	42	47	51	54	58	64	71	73	81						
		48	28	28	32	36	40	45	49	52	56	60	66	67	72	77	82				
		52	26	26	31	34	39	43	47	50	53	57	61	67	69	73	76	80	84		
		56	26	26	30	35	37	42	45	48	52	55	59	62	66	71	76	80	84		
60	25	25	30	34	36	39	44	46	49	53	57	60	64	68	72	75	78				

52' 0" (cont.)	9N@5.78'	36	37	37	43	49	55	59	68	71												
		40	33	33	38	43	50	56	61	65	72											
		44	32	32	37	41	46	52	58	62	66	73										
		48	31	31	35	40	46	50	53	60	63	68	73									
		52	30	30	35	38	44	48	51	55	61	65	69	75	77							
		56	29	29	34	38	43	46	51	53	57	63	67	72	77	81	87	90	92			
	60	28	28	32	37	41	45	50	52	57	61	65	67	73	77	81	85	90	92			
	10N@5.2'	36	30	38	45	51	58	65	72	77	84	92										
		40	29	34	40	46	52	59	66	74	75	87	92	99								
		44	27	31	37	43	47	54	61	65	69	76	80	87	98							
		48	26	31	38	41	48	51	56	63	67	70	77	83	93	102						
		52	25	30	33	40	43	50	53	57	65	68	72	80	80	93	101					
56		24	28	33	38	44	48	52	58	60	66	70	74	82	82	86	94					
60	23	28	33	36	40	46	53	55	61	65	69	72	76	83	84	90	101					
54' 0"	8N@6.75'	36	33	33	39	45	49	56	61	68	75	78										
		40	31	31	37	41	46	50	57	62	67	71	79	80								
		44	29	29	34	38	44	48	51	57	63	65	71	77	81							
		48	28	28	33	38	42	45	50	53	58	63	67	72	74	78	82					
		52	27	27	31	35	40	43	47	51	56	60	64	68	73	77	81	82				
		56	27	27	30	35	38	42	46	50	54	58	62	65	67	71	75	80	84			
	60	25	25	31	34	36	41	45	49	52	56	59	63	65	69	72	76	80				
	64	27	27	31	35	37	40	44	47	50	54	57	61	65	68	71	75	79				
	9N@6.0'	36	37	37	42	49	55	63	70	78	82	91										
		40	34	34	40	46	51	57	64	69	79	79	92									
		44	32	32	38	44	48	54	58	65	70	73	81	86								
		48	31	31	35	42	46	52	56	59	67	72	75	82	83							
52		29	29	34	40	43	49	54	57	61	67	70	76	84	86	89						
56		30	30	35	38	42	48	51	55	59	63	68	71	78	82	86	93					
60	29	29	34	37	43	46	50	53	57	60	64	70	73	77	81	85	89					
64	29	29	34	38	41	45	48	51	55	59	66	70	73	76	80	85	89					

(Continued)

**JOIST GIRDERS  
DESIGN GUIDE WEIGHT TABLE FOR JOIST GIRDERS—(Continued)**

Based on Allowable Tensile Stress of 30,000 psi (207 MPa)  
Joist Girder Weight—Pounds Per Linear Foot (× 14.59 for N/m)

SPAN	NO. OF JOIST SPACES	PANEL PT. LOAD	4K	5K	6K	7K	8K	9K	10K	11K	12K	13K	14K	15K	16K	17K	18K	19K	20K		
		x 4.448 for kN																			
		Depth in Inches																			
x 304.8 for mm		x 25.4 for mm																			
54' 0" (cont.)	10N@5.4'	36	45	45	51	58	67	76	80												
		40	40	40	47	53	61	68	77	80											
		44	40	40	44	50	56	62	70	78	82										
		48	34	34	41	47	54	57	65	71	78	83									
		52	35	35	42	45	50	56	60	67	72	74	81	85							
		56	34	34	39	44	48	53	57	63	68	74	76	82	86						
		60	34	34	37	44	46	50	56	61	64	72	75	77	84						
64	34	34	38	40	46	50	55	60	63	66	74	76	78	84	89						
55' 0"	8N@6.88'	36	34	34	40	45	51	56	63	68	78	78									
		40	31	31	37	43	46	53	56	62	69	71	79	84							
		44	31	31	34	40	44	49	54	57	63	69	73	80	80						
		48	28	28	33	38	42	45	50	55	59	65	67	72	78	80	82				
		52	27	27	32	36	40	44	49	53	56	60	66	68	72	78	83				
		56	26	26	32	35	39	43	47	51	54	57	61	65	69	73	77	81	85		
		60	25	25	31	35	37	42	46	49	52	56	60	62	67	71	74	78	81		
	64	26	26	31	35	37	40	44	48	50	54	57	61	65	68	71	75	79			
	68	27	27	31	34	37	40	44	48	51	53	57	59	63	67	70	73	75			
	9N@6.11'	36	37	37	44	50	55	63	70	78											
		40	34	34	40	46	53	59	64	71	79	84									
		44	32	32	38	44	49	54	60	65	70	80	81								
		48	32	32	36	42	45	52	56	61	67	72	75	82	87						
		52	31	31	35	41	45	50	54	58	63	69	73	76	84						
56		30	30	35	38	42	48	51	55	62	64	70	75	78	82	86					
60		30	30	35	38	43	46	50	53	58	63	66	72	78	81	87	90	93			
64	29	29	34	38	41	45	50	53	58	62	66	68	74	78	82	87	91				
68	29	29	34	37	41	46	49	52	56	60	63	67	72	75	77	82	86				

55' 0" (cont.)	10N@5.5'	36	45	45	51	60	67	76	88												
		40	41	41	48	55	63	68	77	81											
		44	40	40	46	50	56	64	70	79	82										
		48	37	37	43	47	54	59	65	71	80	83									
		52	35	35	41	46	51	56	62	70	72	80	84								
		56	36	36	39	45	48	53	59	63	71	74	82	86	88						
		60	35	35	37	44	47	52	57	61	67	73	75	84	87						
		64	34	34	37	40	47	51	55	60	64	68	74	77	85	87	89				
	68	35	35	37	38	47	49	53	58	64	67	71	77	78	84	89					
	11N@5.0'	36	46	46	54	65	71	80													
		40	45	45	50	58	68	73	81												
		44	41	41	47	53	60	70	74	82											
		48	38	38	44	51	58	65	71	80	82										
		52	37	37	42	48	56	59	67	72	81	84									
56		36	36	43	46	51	57	63	69	74	82	86									
60		36	36	40	46	50	55	61	65	73	77	84	87	88							
64		35	35	39	46	48	54	60	63	71	76	78	85	89							
68	35	35	39	44	48	53	58	63	67	73	78	80	88								
56' 0"	8N@7.0'	36	35	35	40	45	52	56	63	70	78	78									
		40	31	31	37	43	48	53	56	64	69	76	79								
		44	31	31	35	41	44	50	54	57	63	70	73	80	81						
		48	30	30	33	39	43	48	52	56	59	65	70	74	78						
		52	28	28	32	36	40	46	49	53	58	60	66	68	73	78	83				
		56	27	27	32	35	39	44	47	51	54	59	61	67	69	73	77	81	85		
		60	26	26	31	35	38	42	46	48	52	56	60	63	69	72	75	80	84		
		64	26	26	31	35	37	42	44	48	51	55	57	62	65	69	72	76	79		
	68	27	27	32	34	38	41	45	47	51	55	57	59	64	68	72	75	79			
	9N@6.22'	36	39	39	45	52	57	63	70	78											
		40	36	36	43	46	53	60	64	71	79	83									
		44	33	33	38	44	51	54	61	65	72	80	81								
		48	32	32	38	42	47	52	59	62	67	72	81	82							
		52	31	31	36	41	46	50	53	60	64	68	73	76	83						
56		30	30	35	40	44	48	51	56	62	65	70	75	78	82	86					
60		30	30	34	38	43	46	51	56	59	64	67	72	77	81	87	90	93			
64		31	31	34	38	41	45	50	54	58	61	66	69	74	78	82	87	91			
68	29	29	34	38	41	46	48	52	56	60	63	67	72	77	82	86	89				

(Continued)

**JOIST GIRDERS  
DESIGN GUIDE WEIGHT TABLE FOR JOIST GIRDERS—(Continued)**

Based on Allowable Tensile Stress of 30,000 psi (207 MPa)  
Joist Girder Weight—Pounds Per Linear Foot ( × 14.59 for N/m)

SPAN	NO. OF JOIST SPACES	PANEL PT. LOAD	4K	5K	6K	7K	8K	9K	10K	11K	12K	13K	14K	15K	16K	17K	18K	19K	20K	
		x 4.448 for kN																		
		Depth in Inches																		
		x 304.8 for mm																		
56' 0"	10N@5.6'	36	45	45	52	60	68	76	88											
		40	42	42	48	55	63	68	77	89										
		44	40	40	46	53	58	67	70	79	82									
		48	37	37	43	48	54	60	69	72	80	83								
		52	35	35	42	47	51	58	64	69	74	81	84							
		56	36	36	39	45	48	55	59	65	71	75	82	86						
		60	35	35	37	44	47	54	57	63	67	75	76	83	87					
	64	35	35	38	42	47	51	55	61	65	70	76	78	85						
	68	35	35	38	41	47	50	53	60	63	67	72	78	79	85	90				
	11N@5.1'	36	35	47	53	60	67	74												
		40	34	41	48	54	61	68	76											
		44	31	39	45	52	59	63	70	77	82									
		48	31	37	43	50	56	61	65	72	79	84								
		52	30	35	42	48	52	58	66	70	74	81	86							
56		29	34	40	46	53	56	61	68	72	75	83	88							
60		29	34	38	44	48	55	62	63	70	74	78	85	89						
64	28	34	38	43	49	54	58	64	68	72	79	80	87	89						
68	27	33	39	43	47	52	59	62	66	70	74	82	83	90	91	96				
58' 0"	9N@6.44'	36	39	39	45	53	61	67	77	82										
		40	37	37	43	49	56	62	68	75	79									
		44	34	34	41	45	51	57	63	70	72	80								
		48	32	32	38	43	48	53	58	64	71	74	81	86						
		52	32	32	36	42	46	52	56	60	66	72	75	83	83					
		56	30	30	35	41	44	49	54	58	62	67	73	77	85	92				
		60	31	31	35	39	43	48	52	55	61	63	69	75	79	83	87	94		
		64	31	31	36	38	44	47	50	53	58	62	67	71	76	82	87	89	90	
		68	32	32	34	38	42	45	49	53	59	62	66	68	73	77	81	86	91	
		72	31	31	35	39	42	47	49	53	57	61	64	68	73	76	78	82	86	

58' 0"	10N@5.8'	36	48	48	55	65	69	79															
		40	44	44	50	57	66	70	80														
		44	40	40	46	53	61	69	75	81													
		48	39	39	45	50	57	63	70	77	82												
		52	37	37	43	47	53	59	66	71	78	81											
		56	36	36	42	46	52	56	61	70	73	80	82	88									
		60	37	37	40	45	48	53	60	64	72	74	81	83	89								
		64	36	36	37	44	48	50	59	62	67	73	76	82	85	93							
		68	36	36	38	40	48	51	56	61	64	68	75	77	84	87	89						
		72	35	35	38	40	47	50	54	60	64	66	72	77	79	84	89	89				94	
			11N@5.27'	36	41	47	54	61	68	79													
				40	36	42	49	58	65	72	80												
				44	33	42	49	56	63	67	77	78											
				48	33	38	44	50	57	64	71	79	80										
52	32			38	45	48	55	59	66	74	81	81											
56	30			35	41	46	54	60	65	69	76	82	84										
60	30			36	40	47	51	56	63	66	71	77	85	86	91								
64	30			36	39	44	50	57	60	64	72	73	79	87	88	93							
68	29	34	39	45	51	56	60	65	67	74	78	82	89	91	96								
72	29	35	39	45	49	54	61	62	68	73	77	80	85	92	93	96			98				
60' 0"	9N@6.67'	40	38	40	44	49	56	62	68	75	80												
		44	38	38	42	47	53	57	64	70	80	80											
		48	37	38	39	45	50	55	60	65	71	78	81										
		52	36	37	38	44	47	50	54	61	63	69	73	77									
		56	36	36	36	42	46	49	54	58	63	68	70	76	78	82							
		60	35	35	36	40	45	49	54	58	62	68	70	76	78	78	87						
		64	35	35	35	37	43	47	51	52	59	60	65	67	73	73	81	82					
		68	34	34	34	37	43	47	50	53	58	59	65	68	73	75	81	83	93				
72	33	33	34	38	43	46	50	53	58	60	65	68	74	78	82	88	93						

(Continued)

**JOIST GIRDERS  
DESIGN GUIDE WEIGHT TABLE FOR JOIST GIRDERS—(Continued)**

Based on Allowable Tensile Stress of 30,000 psi (207 MPa)  
Joist Girder Weight—Pounds Per Linear Foot (× 14.59 for N/m)

SPAN	NO. OF JOIST SPACES	PANEL PT. LOAD	4K	5K	6K	7K	8K	9K	10K	11K	12K	13K	14K	15K	16K	17K	18K	19K	20K	
		× 4.448 for kN																		
		Depth in Inches																		
× 304.8 for mm		× 25.4 for mm																		
60' 0"	10N@6.0'	40	32	42	49	55	62	69	78											
		44	31	41	49	55	61	69	78	82	94	96								
		48	30	37	45	52	58	68	70	80	82	95	97							
		52	29	35	42	48	52	58	65	72	75	80	87	92						
		56	28	34	42	47	50	57	64	67	74	78	85	89	96					
		60	28	33	41	46	49	55	62	66	72	76	83	87	95					
		64	25	32	39	43	48	52	58	64	66	74	78	80	85	85				
		68	24	30	39	42	48	51	58	63	65	72	77	76	83	84	90	90		
	72	24	38	39	41	48	51	57	61	64	70	76	78	80	84	90	90			
	11N@5.45'	40	33	42	51	58	65	73	77											
		44	33	40	46	53	60	67	74	79										
		48	30	36	44	48	55	62	69	76	81									
		52	30	35	42	48	55	59	65	71	78	82								
		56	29	34	40	46	51	57	65	66	73	79	85							
		60	28	33	39	45	51	55	60	66	71	76	82	86						
		64	28	33	39	45	47	55	60	64	69	76	78	84	89					
		68	28	33	37	42	48	55	56	62	67	71	78	79	87	91				
	72	28	32	38	42	49	51	58	61	65	72	73	81	82	89	94				
	12N@5.0'	40	39	47	53	64	73	81												
		44	38	47	53	64	70	81	93	94										
		48	37	43	51	58	66	74	82	94	96									
		52	32	39	46	52	57	64	71	79	84									
		56	31	38	44	52	57	62	68	75	83	86								
		60	31	38	44	52	57	62	68	75	83	86	99							
64		30	35	40	47	54	58	65	70	77	78	85	91							
68		30	35	41	48	53	57	64	68	73	80	87	89	93						
72	30	37	41	48	53	58	62	66	73	79	84	91	92							

**Division IV—DESIGN STANDARD FOR STRUCTURAL JOINTS  
USING HIGH-STRENGTH BOLTS**

**Based on the Allowable Stress Design Specification for Structural Joints Using  
ASTM A 325 or A 490 Bolts**

**Approved by the Research Council on Structural Connections of the Engineering  
Foundation, November 18, 1985, and endorsed by American Institute of Steel  
Construction and by Industrial Fasteners Institute**

**SECTION 2220 — SCOPE**

This division relates to the allowable stress design for strength and slip resistance of structural joints using A 325 high-strength bolts, A 490 heat-treated high-strength bolts or equivalent fasteners, and for the installation of such bolts in connections of structural steel members. The division relates only to those aspects of the connected materials that bear upon the performance of the fasteners.

Construction shall conform to applicable requirements of this code except as otherwise provided herein.

**SECTION 2221 — BOLTS, NUTS, WASHERS AND PAINT**

**2221.1 Bolt Specifications.** Bolts shall conform to the requirements of U.B.C. Standard 22-1 except as provided in Section 2221.4. The designer shall specify the type of bolts to be used.

**2221.2 Bolt Geometry.** Bolt dimensions shall conform to Table 22-IV-F, except as provided in Section 2221.4. The length of bolts shall be such that the end of the bolt will be flush with or outside the face of the nut.

**2221.3 Nut Specifications.** Nuts shall conform to the chemical and mechanical requirements of Tables 22-IV-G, 22-IV-H and 22-IV-I. The grade and surface finish of nuts for each bolt type shall be as follows:

<b>A 325 Bolt Type</b>	<b>Nut Specifications, Grade and Finish</b>
1 and 2, plain (uncoated)	C, C3, D, DH and DH3 or 2 and 2H; plain
1 and 2, galvanized	DH or 2H; galvanized
3 plain	C3 and DH3
<b>A 490 Bolt Type</b>	<b>Nut Specifications, Grade and Finish</b>
1 and 2, plain	DH and DH3 or 2H; plain
3 plain	DH3

Nut dimensions shall conform to the requirements of Table 22-IV-J except as provided in Section 2221.4.

**2221.4 Alternate Fastener Designs.** Other fasteners or fastener assemblies which meet the materials, manufacturing, chemical composition and mechanical property requirements of A 325 or A 490 high-strength bolts and which have a body diameter and bearing areas under the head and nut not less than those provided by a bolt and nut of the same nominal dimensions prescribed by Sections 2221.2 and 2221.3, may be used. Such alternate fasteners may differ in other dimensions from those of the specified bolts and nuts. Their installation procedure and inspection may differ from procedures specified for regular high-strength bolts in Sections 2227 and 2228. When a different installation procedure or inspection is used, it shall be detailed in a supplemental specification applying to the alternate fastener and that specification must be approved by the engineer responsible for the design of the structure.

**2221.5 Washers.** Flat circular washers and square or rectangular beveled washers shall conform to the requirements of Tables 22-IV-K, 22-IV-L, 22-IV-M and 22-IV-N.

**2221.6 Load-indicating Devices.** Load-indicating devices may be used in conjunction with bolts, nuts and washers specified in Section 2221.1 through 2221.3, provided they satisfy the requirements of Section 2227.4.4. Their installation procedure and inspection shall be detailed in supplemental specifications provided by the manufacturer and subject to the approval of the engineer responsible for the design of the structure.

**2221.7 Faying Surface Coatings.** Paint, if used on faying surfaces of connections which are not specified to be slip critical, may be of any formulation. Paint, used on the faying surfaces of connections specified to be slip critical, shall be qualified by approved test methods to determine the slip coefficient for coatings used in bolted joints.

## SECTION 2222 — BOLTED PARTS

**2222.1 Connected Material.** All material within the grip of the bolt shall be steel. There shall be no compressible material such as gaskets or insulation within the grip. Bolted steel parts shall fit solidly together after the bolts are tightened and may be coated or noncoated. The slope of the surfaces of parts in contact with the bolt head or nut shall not exceed 1:20 with respect to a plane normal to the bolt axis.

**2222.2 Surface Conditions.** When assembled, all joint surfaces, including surfaces adjacent to the bolt head and nut, shall be free of scale, except tight mill scale, and shall be free of dirt or other foreign material. Burrs that would prevent solid seating of the connected parts in the snug tight condition shall be removed.

Paint is permitted on the faying surfaces unconditionally in connections, except in slip-critical connections as defined in Section 2224.1.

The faying surfaces of slip-critical connections shall meet the requirements of the following paragraphs, as applicable.

1. In noncoated joints, paint, including any inadvertent overspray, shall be excluded from areas closer than one bolt diameter but not less than 1 inch from the edge of any hole and all areas within bolt pattern.

2. Joints specified to have painted faying surfaces shall be blast cleaned and coated with a paint which has been qualified as Class A or B in accordance with the requirements of Section 2221.7, except as provided in Section 2222.2, Item 3.

3. Subject to the approval of the building official, coatings providing a slip coefficient less than 0.33 may be used, provided the mean slip coefficient is established by test in accordance with the requirements of Section 2221.7 and the allowable slip load per unit area established. The allowable slip load per unit shall be taken as equal to the allowable slip load per unit area from Table 22-IV-C for Class A coatings as appropriate for the hole type and bolt type times the slip coefficient determined by test divided by 0.33.

4. Coated joints shall not be assembled before the coatings have cured for the minimum time used in the qualifying test.

5. Galvanized faying surfaces shall be hot dip galvanized in accordance with Table 22-IV-O and shall be roughened by means of hand wire brushing. Power wire brushing is not permitted.

**2222.3 Hole Types.** Hole types recognized under this specification are standard holes, oversize holes, short slotted holes and long slotted holes. The nominal dimensions for each type hole shall not be greater than those shown in Table 22-IV-A. Holes shall not be more than  $1/32$  inch (0.8 mm) larger in diameter than the true decimal equivalent of the nominal diameter. The slightly conical hole that naturally results from punching operations is considered acceptable. The width of slotted holes which are produced by flame cutting or a combination of drilling or punching and flame cutting shall generally not be more than  $1/32$  inch (0.8 mm) greater than the nominal width, except that gouges not more than  $1/16$  inch (1.6 mm) deep shall be permitted. For statically loaded connections,

the flame-cut surface need not be ground. For dynamically loaded connections, the flame-cut surface shall be ground smooth.

## SECTION 2223 — DESIGN FOR STRENGTH OF BOLTED CONNECTIONS

**2223.1 Allowable Strength.** The allowable working stress in shear and bearing, independent of the method of tightening, for A 325 and A 490 bolts shall be as set forth in Table 22-IV-B. The allowable working stress in axial tension for A 325 and A 490 bolts which are tightened to the minimum fastener tension shall be in accordance with Table 22-IV-D. The allowable working stresses in Table 22-IV-B are to be used in conjunction with the cross-sectional area of the bolt corresponding to the nominal diameter.

**2223.2 Bearing Force.** The computed bearing force shall be assumed to be distributed over an area equal to the nominal bolt diameter times the thickness of the connected part.

A value of allowable bearing pressure on the connected material at a bolt greater than permitted by Table 22-IV-B may be justified, provided deformation around the bolt hole is not a design consideration and adequate pitch and end distance  $L$  is provided according to:

$$F_p = LF_u/2d \leq 1.5F_u$$

### WHERE:

$d$  = bolt diameter.

$F_p$  = allowable bearing pressure at a bolt.

$F_u$  = specified minimum tensile strength of connected part.

**2223.3 Prying Action.** The force in bolts required to support loads by means of direct tension shall be calculated considering the effects of the external load and any tension resulting from prying action produced by deformation of the connected parts.

**2223.4 Tensile Fatigue.** When subject to tensile fatigue loading, the tensile stress in the bolt due to the combined applied load and prying forces shall not exceed the following values, depending upon the bolt grade and number of cycles, and the prying force shall not exceed 60 percent of the externally applied load.

Number of Cycles	A 325	A 490
	× 6.89 for MPa	
Not more than 20,000	44	54
From 20,000 to 500,000	40	49
More than 500,000	31	38

Bolts shall be tensioned to requirements of Table 22-IV-D.

## SECTION 2224 — DESIGN CHECK FOR SLIP RESISTANCE

**2224.1 Slip-critical Joints.** Slip-critical joints are defined as joints in which slip would be detrimental to the serviceability of the structure. They include:

1. Joints subject to fatigue loading.
2. Joints with bolts installed in oversized holes.
3. Except where the engineer intends otherwise and so indicates in the plans or specifications, joints with bolts installed in slotted holes where the force on the joint is in a direction other than normal (between approximately 80 and 100 degrees) to the axis of the slot.
4. Joints subject to significant load reversal.

5. Joints in which welds and bolts are in transmitting load at a common faying surface.
6. Joints in which any slip would be critical to the performance of the joint or the structure and so designated on the contract plans and specifications.

**2224.2 Allowable Slip Load.** In addition to the requirements of Section 2223, the force on a slip-critical joint shall not exceed the allowable resistance  $P_s$  of the connection according to:

$$P_s = F_s A_b N_b N_s$$

**WHERE:**

- $A_b$  = area corresponding to the nominal body area of the bolt.
- $F_s$  = allowable slip load per unit area of bolt from Table 22-IV-C.
- $N_b$  = number of bolts in the joint.
- $N_s$  = number of slip planes.

Class A, B or C surface conditions of the bolted parts as defined in Table 22-IV-C shall be used in joints designated as slip-critical except as permitted in Section 2222.2, Item 3.

**SECTION 2225 — INCREASE IN ALLOWABLE STRESSES**

When an increase in working stress for loads in combination with wind or seismic forces is permitted, increases in working stresses may be applied with wind or seismic forces. The increases in working stresses may be applied to the allowable stresses in Sections 2223 and 2224. When the effect of loads in combination with wind or seismic forces are accounted for by reduction in the load factors, the allowable stresses in Sections 2223 and 2224 shall not be increased.

**SECTION 2226 — DESIGN DETAILS OF BOLTED CONNECTIONS**

**2226.1 Standard Holes.** In the absence of approval by the engineer for use of other hole types, standard holes shall be used in high-strength bolted connections.

**2226.2 Oversize and Slotted Holes.** When approved by the building official, oversize, short-slotted holes or long-slotted holes may be used, subject to the following joint detail requirements:

1. Oversize holes may be used in all plies of connections in which the allowable slip resistance of the connection is greater than the applied load.
2. Short-slotted holes may be used in any or all plies of connections designed on the basis of allowable stress on the fasteners in Table 22-IV-B, provided the load is applied approximately normal (between 80 and 100 degrees) to the axis of the slot. Short-slotted holes may be used without regard for the direction of applied load in any or all plies of connections in which the allowable slip resistance is greater than the applied force.
3. Long-slotted holes may be used in one of the connected parts at any individual faying surface in connections designed on the basis of allowable stress on the fasteners in Table 22-IV-B, provided the load is applied approximately normal (between 80 and 100 degrees) to the axis of the slot. Long-slotted holes may be used in one of the connected parts at any individual faying surface without regard for the direction of applied load on connections in which the allowable slip resistance is greater than the applied force.
4. Fully inserted finger shims between the faying surfaces of load transmitting elements of connections are not to be considered a long-slot element of a connection.

**2226.3 Washer Requirements.** Design details shall provide for washers in high-strength bolted connections as follows:

1. Where outer face of the bolted parts has a slope greater than 1 unit vertical in 20 units horizontal (5% slope) with respect to a plane normal to the bolt axis, a hardened beveled washer shall be used to compensate for the lack of parallelism.
2. Hardened washers are not required for connections using A 325 and A 490 bolts except as required in Section 2226.3, Items 3 through 7 for slip-critical connections and connections subject to direct tension or as required by Section 2227.3 for shear/bearing connections.
3. Hardened washers shall be used under the element turned in tightening when the tightening is to be performed by calibrated wrench method.
4. Irrespective of the tightening method, hardened washers shall be used under both the head and the nut when A 490 bolts are to be installed and tightened to the tension specified in Table 22-IV-D in material having a specified yield point less than 40 ksi (276 kPa).
5. Where A 325 of any diameter or A 490 bolts equal to or less than 1 inch (25.4 mm) in diameter are to be installed and tightened in an oversize or short-slotted hole in an outer ply, a hardened washer conforming to Section 2221.5 shall be used.
6. When A 490 bolts over 1 inch in diameter are to be installed and tightened in an oversize or short slotted hole in an outer ply, hardened washers conforming to Section 2221.5, except washers with  $\frac{5}{16}$ -inch (7.9 mm) minimum thickness, shall be used under both the head and the nut in lieu of standard thickness hardened washers. Multiple hardened washers with combined thickness equal to or greater than  $\frac{5}{16}$  inch (7.9 mm) do not satisfy this requirement.
7. Where A 325 bolts of any diameter or A 490 bolts equal to or less than 1 inch (25.4 mm) in diameter are to be installed and tightened in a long-slotted hole in an outer ply, a plate washer or continuous bar of at least  $\frac{5}{16}$ -inch (7.9 mm) thickness with standard holes shall be provided. These washers or bars shall have a size sufficient to completely cover the slot after installation and shall be of structural grade material, but need not be hardened except as follows: When A 490 bolts over 1 inch (25.4 mm) in diameter are to be used in long-slotted holes in external plies, a single hardened washer conforming to Section 2221.5 but with  $\frac{5}{16}$ -inch (7.9 mm) minimum thickness shall be used in lieu of washers or bars of structural grade material. Multiple hardened washers with combined thickness equal to or greater than  $\frac{5}{16}$  inch (7.9 mm) do not satisfy this requirement.
8. Alternate design fasteners meeting the requirements of Section 2221.4 with a geometry which provides a bearing circle on the head or nut with a diameter equal to or greater than the diameter of hardened washers meeting the requirements of Section 2221.5 satisfy the requirements for washers specified in Section 2226.3, Items 4 and 5.

## SECTION 2227 — INSTALLATION AND TIGHTENING

**2227.1 Handling and Storage of Fasteners.** Fasteners shall be protected from dirt and moisture at the jobsite. Only as many fasteners as are anticipated to be installed and tightened during a work shift shall be taken from protected storage. Fasteners not used shall be returned to protected storage at the end of the shift. Fasteners shall not be cleaned of lubricant that is present in the as-delivered condition. Fasteners for slip-critical connections which must be cleaned of accumulated rust or dirt resulting from on-site conditions shall be cleaned and relubricated prior to installation.

**2227.2 Tension Calibrator.** A tension-measuring device shall be provided at jobsites where bolts in slip-critical joints or connections subject to direct tension are being installed and tightened. The tension-measuring device shall be used to confirm: (1) the suitability to satisfy the requirements of Table 22-IV-D of the complete fastener assembly, including lubrication if required to be used in the work, (2) calibration of wrenches, if applicable, and (3) the understanding and proper use by the bolting crew of the method to be used. The frequency of confirmation testing, the number of tests to be performed and the test procedure shall be as specified in Section 2227.4, as applicable. The accuracy of the tension-measuring device shall be confirmed through calibration by an approved testing agency at least annually.

**2227.3 Joint Assembly and Tightening of Shear/Bearing Connections.** Bolts in connections not requiring full pretension shall be installed in properly aligned holes, but need only be tightened to the snug-tight condition. The snug-tight condition is defined as the tightness that exists when all plies in a joint are in firm contact. This may be attained by a few impacts of an impact wrench or the tightening a person can achieve with full strength with an ordinary spud wrench. If a slotted hole occurs in an outer ply, a flat hardened washer or common plate washer shall be installed over the slot. Bolts which may be tightened only to a snug-tight condition shall be clearly identified on the drawings.

**2227.4 Joint Assembly and Tightening of Connections Requiring Full Pretension.**

**2227.4.1 General.** In connections requiring full pretension, fasteners, together with washers of size and quality specified, located as required by Section 2226.3 shall be installed in properly aligned holes and tightened by one of the methods described in Section 2227.4 to at least the minimum tension specified in Table 22-IV-D when all the fasteners are tight. Tightening may be done by turning the bolt while the nut is prevented from rotating when it is impractical to turn the nut. Impact wrenches, if used, shall be of adequate capacity and sufficiently supplied with air to perform the required tightening of each bolt in approximately 10 seconds.

**2227.4.2 Turn-of-nut tightening.** When turn-of-nut tightening is used, hardened washers are not required except as may be specified in Section 2226.3.

A representative sample of not less than three bolts and nuts of each diameter, length and grade to be used in the work shall be checked at the start of work in a device capable of indicating bolt tension. The test shall demonstrate that the method of estimating the snug-tight condition and controlling turns from snug tight to be used by the bolting crews develops a tension not less than 5 percent greater than the tension required by Table 22-IV-D.

Bolts shall be installed in all holes of the connection and brought to a snug-tight condition. "Snug tight" is defined as the tightness that exists when the plies of the joint are in firm contact. This may be attained by a few impacts of an impact wrench or the tightening a person can achieve with full strength with an ordinary spud wrench. Snug tightening shall progress systematically from the most rigid part of the connection to the free edges, and then the bolts of the connection shall be retightened in a similar systematic manner as necessary until all bolts are simultaneously snug tight and the connection shall be tightened further by the applicable amount of rotation specified in Table 22-IV-E. During the tightening operation there shall be no rotation of the part not turned by the wrench. Tightening shall progress systematically from the most rigid part of the joint to its free edges.

**2227.4.3 Calibrated wrench tightening.** Calibrated wrench tightening may be used only when installation procedures are calibrated on a daily basis and when a hardened washer is used under the element turned in tightening. This specification does not recognize standard torques determined from tables or from formulas which are assumed to relate torque to tension.

When calibrated wrenches are used for installation, they shall be set to provide a tension not less than 5 percent in excess of the minimum tension specified in Table 22-IV-D. The installation procedures shall be calibrated at least once each working day for each bolt diameter, length and grade using fastener assemblies that are being installed in the work. Calibration shall be accomplished in a device capable of indicating actual bolt tension by tightening three typical bolts of each diameter, length and grade from the bolts being installed and with a hardened washer from the washers being used in the work under the element turned in tightening. Wrenches shall be recalibrated when significant difference is noted in the surface condition of the bolts threads, nuts or washers. It shall be verified during actual installation in the assembled steel work that the wrench adjustment selected by the calibration does not produce a nut or bolt head rotation from snug tight greater than that permitted in Table 22-IV-E. If manual torque wrenches are used, nuts shall be turned in the tightening direction when torque is measured.

When calibrated wrenches are used to install and tension bolts in a connection, bolts shall be installed with hardened washers under the element turned in tightening bolts in all holes of the connection and brought to a snug-tight condition. Following this initial tightening operation, the connection shall be tightened using the calibrated wrench. Tightening shall progress systematically from the most rigid part of the joint to its free edges. The wrench shall be returned to “touch up” previously tightened bolts which may have been relaxed as a result of the subsequent tightening of adjacent bolts until all bolts are tightened to the prescribed amount.

**2227.4.4 Installation of alternate design bolts.** When fasteners which incorporate a design feature intended to indirectly indicate the bolt tension or to automatically provide the tension required by Table 22-IV-D and which have been qualified under Section 2221.4 are to be installed, a representative sample of not less than three bolts of each diameter, length and grade shall be checked at the jobsite in a device capable of indicating bolt tension. The test assembly shall include flat hardened washers, if required in the actual connection, arranged as in the actual connections to be tensioned. The calibration test shall demonstrate that each bolt develops a tension not less than 5 percent greater than the tension required by Table 22-IV-D. Manufacturer’s installation procedure as required by Section 2221.4 shall be followed for installation of bolts in the calibration device and in all connections.

When alternate design features of the fasteners involve an irreversible mechanism such as yield or twist-off of an element, bolts shall be installed in all holes of the connection and initially brought to a snug-tight condition. All fasteners shall then be tightened, progressing systematically from the most rigid part of the connection of the free edges in a manner that will minimize relaxation of previously tightened fasteners prior to final twist-off or yielding of the control or indicator element of the individual fasteners. In some cases, proper tensioning of the bolts may require more than a single cycle of systematic tightening.

**2227.4.5 Direct-tension indicator tightening.** Tightening of bolts using direct-tension-indicator devices is permitted, provided the suitability of the device can be demonstrated by testing a representative sample of not less than three devices for each diameter and grade of fastener in a calibration device capable of indicating bolt tension. The test assembly shall include flat hardened washers, if required in the actual connection, arranged as those in the actual connections to be tensioned. The calibration test shall demonstrate that the device indicates a tension not less than 5 percent greater than that required by Table 22-IV-D. Manufacturer’s installation procedure as required by Section 2221.4 shall be followed for installation of bolts in the calibration device and in all connections. Special attention shall be given to proper installation of flat hardened washers when load-indicating devices are used with bolts installed in oversize or slotted holes and when the load indicating devices are used under the turned elements.

When the direct tension involves an irreversible mechanism such as yielding or fracture of an element, bolts shall be installed in all holes of the connection and brought to snug-tight conditions. All fasteners shall then be tightened, progressing systematically from the most rigid part of the connection to the free edges in a manner that will minimize relaxation of previously tightened fasteners prior to final twist-off or yielding of the control or indicator element of the individual devices. In some cases, proper tensioning of the bolts may require more than a single cycle of systematic tightening.

**2227.5 Reuse of Bolts.** A 490 and galvanized A 325 bolts shall not be reused. Other A 325 bolts may be reused if approved by the building official. Touching up or retightening previously tightened bolts which may have been loosened by the tightening of adjacent bolts shall not be considered as reuse provided the snugging up continues from the initial position and does not require greater rotation, including the tolerance, than that required by Table 22-IV-E.

## SECTION 2228 — INSPECTION

**2228.1 Inspector Responsibility.** While the work is in progress, the special inspector shall determine that the requirements of Sections 2221, 2222 and 2227 are met. Such inspections may be per-

formed on a periodic basis in accordance with the requirements of Section 1701.5, Item 6, of the code. The special inspector shall observe the calibration procedures when such procedures are required by the plans or specifications and shall monitor the installation of bolts to determine that all plies of connected material have been drawn together and that the selected procedure is properly used to tighten all bolts.

In addition, all connections specified to be slip critical or subject to axial tension, the special inspector shall assure that the specified procedure was followed to achieve the pretension specified in Table 22-IV-D. Bolts installed by procedures in Section 2227.4 may reach tensions substantially greater than values given in Table 22-IV-D, but this shall not be cause for rejection.

Bolts in connections identified as not being slip critical nor subject to direct tension need not be inspected for bolt tension other than to ensure that the plies of the connected elements have been brought into snug contact.

**2228.2 Arbitration Inspection.** When high-strength bolts in slip-critical connections and connections subject to direct tension have been installed by any of the tightening methods in Section 2227.4 and inspected in accordance with Section 2228.1 and a disagreement exists as to the minimum tension of the installed bolts, the following arbitration procedure may be used. Other methods for arbitration inspection may be used if approved by the building official.

1. The special inspector shall use a manual torque wrench which indicates torque by means of a dial or which may be adjusted to give an indication that the job inspecting torque has been reached.

2. This standard does not recognize standard torques determined from tables or from formulas which are assumed to relate torque to tension. Testing using such standard torques shall not be considered valid.

3. A representative sample of five bolts from the diameter, length and grade of the bolts used in the work shall be tightened in the tension measuring device by a convenient means to an initial condition equal to approximately 15 percent of the required fastener tension and then to the minimum tension specified in Table 22-IV-D. Tightening beyond the initial condition must not produce greater nut rotation than one and one-half times that permitted in Table 22-IV-E. The job inspecting torque shall be taken as the average of three values thus determined after reflecting the high and low values. The inspecting wrench shall then be applied to the tightened bolts in the work and the torque necessary to turn the nut or head 5 degrees [approximately 1 inch (25 mm) at 12-inch (305 mm) radius] in the tightening direction shall be determined.

4. Bolts represented by the sample in the foregoing paragraph which have been tightened in the structure shall be inspected by applying, in the tightening direction, the inspecting wrench and its job torque to 10 percent of the bolts, but not less than two bolts, selected at random in each connection in question. If no nut or bolt head is turned by application of the job inspecting torque, the connection shall be accepted as properly tightened. If any nut or bolt is turned by the application of the job inspecting torque, all bolts in the connection shall be tested, and all bolts whose nut or head is turned by the job inspecting torque shall be tightened and reinspected. Alternatively, the fabricator or erector, at his option, may retighten all of the bolts in the connection and then resubmit the connection for the specified inspection.

**2228.3 Delayed Verification Inspection.** The procedure specified in Sections 2228.1 and 2228.2 are intended for inspection of bolted connections and verification of pretension at the time of tensioning the joint. If verification of bolt tension is required after a passage of a period of time and exposure of the completed joints, the procedures of Section 2228.2 will provide indication of bolt tension which is of questionable accuracy. Procedures appropriate to the specific situation should be used for verification of bolt tension. This might involve use of the arbitration inspection procedure contained herein, or might require the development and use of alternate procedures.

TABLE 22-IV-A—NOMINAL HOLE DIMENSIONS

BOLT DIAMETER	HOLE DIMENSIONS			
	Standard (Diameter)	Oversize (Diameter)	Short Slot (Width x Length)	Long Slot (Width x Length)
× 25.4 for mm				
1/2	9/16	5/8	9/16 × 11/16	9/16 × 1 1/4
5/8	11/16	13/16	11/15 × 7/8	11/16 × 1 9/16
3/4	13/16	15/16	13/16 × 1	13/16 × 1 7/8
7/8	15/16	1 1/16	15/16 × 1 1/8	15/16 × 2 3/16
1	1 1/16	1 1/4	1 1/16 × 1 5/16	1 1/16 × 2 1/2
≥ 1 1/8	d + 1/16	d + 5/16	(d + 1/16) × (d + 3/8)	(d + 1/16) × (2.5 × d)

TABLE 22-IV-B—ALLOWABLE WORKING STRESS<sup>1</sup> ON FASTENERS OR CONNECTED MATERIAL (ksi) (× 6.89 for MPa)

LOAD CONNECTION	A 325	A 490
Applied static tension <sup>2, 3</sup>	44	54
Shear on bolt with threads in shear plane.	21 <sup>4</sup>	28 <sup>4</sup>
Shear on bolt without threads in shear plane.	30 <sup>4</sup>	40 <sup>4</sup>
Bearing on connected material with single bolt in line of force in a standard or short-slotted hole.	1.0F <sub>u</sub> <sup>5</sup>	
Bearing on connected material with two or more bolts in line of force in standard or short-slotted holes.	1.2F <sub>u</sub> <sup>5</sup>	
Bearing on connected material in long-slotted holes.	1.0F <sub>u</sub> <sup>5</sup>	

<sup>1</sup>Ultimate failure load divided by factor of safety.

<sup>2</sup>Bolts must be tensioned to requirements of Table 22-IV-D.

<sup>3</sup>See Section 2223.4 for bolts subject to tensile fatigue.

<sup>4</sup>In connections transmitting axial force whose length between extreme fasteners measured parallel to the line of force exceeds 50 inches (1270 mm), tabulated values shall be reduced 20 percent.

<sup>5</sup>F<sub>u</sub> = specified minimum tensile strength of connected part.

Connections using high-strength bolts in slotted holes with the load applied in a direction other than approximately normal (between 80 and 100 degrees) to the axis of the hole and connections with bolts in oversize holes shall be designated for resistance against slip at working load in accordance with Section 222.4.

Tabulated values apply when the distance L parallel to the line of force from the center of the bolt to the edge of the connected part is not less than 1 1/2d and the distance from the center of a bolt to the center of an adjacent bolt is not less than 3 (d). When either of these conditions is not satisfied, the distance L requirement of Section 2223.2 determines allowable bearing stress.

Except as may be justified under provisions of Section 2223.2.

**TABLE 22-IV-C—ALLOWABLE LOAD FOR SLIP-CRITICAL CONNECTIONS**  
(Slip Load per Unit of Bolt Area, ksi) (x 6.89 for MPa)

CONTACT SURFACE OF BOLTED PARTS	HOLE TYPE AND DIRECTION OF LOAD APPLICATION							
	Any Direction				Transverse		Parallel	
	Standard		Oversize and Short Slot		Long Slots		Long Slots	
	A 325	A 490	A 325	A 490	A 325	A 490	A 325	A 490
Class A (Slip Coefficient 0.33) Clean mill scale and blast-cleaned surfaces with Class A coatings <sup>1</sup>	17	21	15	18	12	15	10	13
Class B (Slip Coefficient 0.50) Blast-cleaned surfaces and blast-cleaned surfaces with Class B coatings <sup>1</sup>	28	34	24	29	20	24	17	20
Class C (Slip Coefficient 0.40) Hot dip galvanized and roughened surfaces	22	27	19	23	16	19	14	16

<sup>1</sup>Coatings classified as Class A or Class B includes those coatings which provide a mean slip coefficient not less than 0.33 or 0.50, respectively, as determined by approved methods.

**TABLE 22-IV-D—FASTENER TENSION REQUIRED FOR SLIP-CRITICAL CONNECTIONS AND CONNECTIONS SUBJECT TO DIRECT TENSION**

NOMINAL BOLT SIZE, INCHES	MINIMUM TENSION <sup>1</sup> IN 1000's OF POUNDS (kips)	
	x 4448 for N	
	A 325 Bolts	A 490 Bolts
x 25.4 for mm		
1/2	12	15
5/8	19	24
3/4	28	35
7/8	39	49
1	51	64
1 1/8	56	80
1 1/4	71	102
1 3/8	85	121
1 1/2	103	143

<sup>1</sup>Equal to 70 percent of specified minimum tensile strength of bolts (as specified for tests of full-size A 325 and A 490 bolts with UNC threads loaded in axial tension) rounded to the nearest kip.

**TABLE 22-IV-E—NUT ROTATION FROM SNUG-TIGHT CONDITION<sup>1,2</sup>**

BOLT LENGTH (Underside of head to end of bolt)	DISPOSITION OF OUTER FACE OF BOLTED PARTS		
	Both faces normal to bolt axis	One face normal to bolt axis and other sloped not more than 1:20 (beveled washer not used)	Both faces sloped not more than 1:20 from normal to the bolt axis (beveled washer not used)
Up to and including 4 diameters	1/3 turn	1/2 turn	2/3 turn
Over 4 diameters but not exceeding 8 diameters	1/2 turn	2/3 turn	5/6 turn
Over 8 diameters but not exceeding 12 diameters <sup>3</sup>	2/3 turn	5/6 turn	1 turn

<sup>1</sup>For bolts installed by 1/2 turn and less, the tolerance shall be plus or minus 30 degrees; for bolts installed by 2/3 turn and more, the tolerance shall be plus or minus 45 degrees.

<sup>2</sup>Applicable only to connections in which all material within the grip of the bolt is steel.

<sup>3</sup>The rotation shall be determined by actual test in a suitable tension measuring device which simulates conditions of solidly fitted steel.

TABLE 22-IV-F—DIMENSIONS OF HEAVY HEX STRUCTURAL BOLTS<sup>1</sup>

× 25.4 for mm										
NOMINAL SIZE	E		F		H	R		L <sub>T</sub>	Y	RUNOUT OF BEARING SURFACE FIM <sup>7</sup>
	BODY DIAMETER <sup>3, 4</sup>		WIDTH ACROSS FLATS <sup>5, 6</sup>		HEIGHT	RADIUS OF FILLET		THREAD LENGTH <sup>2</sup>	TRANSITION THREAD LENGTH <sup>2</sup>	
	MAX.	MIN.	BASIC/MAX.	MIN.	MIN.	MAX.	MIN.	BASIC	MAX.	MAX.
1/2	0.515	0.482	0.875	0.850	0.302	0.031	0.009	1.00	0.19	0.016
5/8	0.642	0.605	1.062	1.031	0.378	0.062	0.021	1.25	0.22	0.019
3/4	0.768	0.729	1.250	1.212	0.455	0.062	0.021	1.38	0.25	0.022
7/8	0.895	0.852	1.438	1.394	0.531	0.062	0.031	1.50	0.28	0.025
1	1.022	0.976	1.625	1.575	0.591	0.093	0.062	1.75	0.31	0.028
1 1/8	1.149	1.098	1.812	1.756	0.658	0.093	0.062	2.00	0.34	0.032
1 1/4	1.277	1.223	2.000	1.938	0.749	0.093	0.062	2.00	0.38	0.035
1 3/8	1.404	1.345	2.188	2.119	0.810	0.093	0.062	2.25	0.44	0.038
1 1/2	1.531	1.470	2.375	2.300	0.902	0.093	0.062	2.25	0.44	0.041

(Continued)

## FOOTNOTES TO TABLE 22-IV-F

- <sup>1</sup>**Identification Symbols.** Identification marking symbols on the tops of heads for bolt sizes  $\frac{5}{8}$  inch (16 mm) and smaller shall project not less than 0.005 inch (0.13 mm) above the surface nor more than 0.015 inch (0.38 mm) over the specified maximum head height. Bolt sizes larger than  $\frac{5}{8}$  inch (16 mm) shall project not less than the equivalent in inches of 0.0075 times the basic bolt diameter above the surface nor more than 0.030 inch (0.76 mm) over the specified maximum head height.
- <sup>2</sup>The length of thread on bolts shall be controlled by the grip gauging length  $L_G$  max. and body length  $L_B$  min. as set forth in the following:
- Grip gauging length,  $L_G$  max., is the distance measured parallel to the axis of bolt from the underhead bearing surface to the face of a noncounterbored or noncountersunk standard GO thread ring gauge assembled by hand as far as the thread will permit. It shall be used as the criterion for inspection. The maximum grip gauging length, as calculated and rounded to two decimal places for any bolt not threaded full length, shall be equal to the nominal bolt length minus the basic thread length ( $L_G$  max. =  $L$  nom -  $L_T$ ). For bolts which are threaded full length,  $L_B$  max. defines the unthreaded length under the head and shall not exceed the length of 2.5 times the thread pitch for sizes up to and including 1 inch (25 mm), and 3.5 times the thread pitch for sizes larger than 1 inch (25 mm).  $L_G$  max. represents the minimum design grip length of the bolt and shall be used for determining thread availability when selecting bolt lengths even though usable threads may extend beyond this point.
- Basic thread length,  $L_T$ , is a reference dimension, intended for calculation purposes only, which represents the distance from the extreme end of the bolt to the last complete (full form) thread.
- Body length,  $L_B$  min., is the distance measured parallel to the axis of bolt from the underhead bearing surface to the last scratch of thread or to the top of the extrusion angle. It shall be used as a criterion for inspection. The minimum body length as calculated and rounded to two decimal places shall be equal to the maximum grip gauging length minus the maximum transition thread length ( $L_B$  min. =  $L_G$  max. -  $Y$  max.). Bolts of nominal lengths which have a calculated  $L_B$  min. length equal to or shorter than 2.5 times the thread pitch for sizes 1 inch (25 mm) and smaller and 3.5 times the thread pitch for sizes larger than 1 inch (25 mm) shall be threaded for full length.
- Transition thread length,  $Y$ , is a reference dimension, intended for calculation purposes only, which represents the length of incomplete threads and tolerance on grip gauging length.
- The major diameter of incomplete thread shall not exceed the actual major diameter of the full form thread.
- Threads, when rolled, shall be in the unified inch coarse or 8 thread series (UNRC or 8 UNR Series), Class 2A. Threads produced by other methods may be unified inch coarse or 8 thread series (UNC or 8 UN Series), Class 2A.
- <sup>3</sup>There may be a reasonable swell or fin under the head, or die seam on the body not to exceed the basic bolt diameter by the following:
- 0.030 inch (0.76 mm) for sizes  $\frac{1}{2}$  inch (13 mm)
  - 0.050 inch (1.27 mm) for sizes  $\frac{5}{8}$  inch (16 mm) and  $\frac{3}{4}$  inch (19 mm)
  - 0.060 inch (1.52 mm) for sizes over  $\frac{3}{4}$  inch (19 mm) to  $1\frac{1}{4}$  inches (32 mm)
  - 0.090 inch (2.29 mm) for sizes over  $1\frac{1}{4}$  inches (32 mm)
- <sup>4</sup>Shanks of bolts shall be straight within the following limits: for bolts with nominal lengths to and including 12 inches (305 mm), the maximum camber shall be 0.006 inch (0.15 mm) per inch (25 mm) of bolt length, and for bolts with nominal lengths over 12 inches (305 mm) to and including 24 inches (610 mm), the maximum camber shall be 0.008 inch (0.20 mm) per inch (25 mm) of length.
- <sup>5</sup>Maximum width across flats shall not be exceeded. No transverse section through the head between 25 and 75 percent of actual head height as measured from the bearing surface shall be less than the minimum width across flats.
- <sup>6</sup>The axis of the head shall be located at true position with respect to the axis of the body (determined over a distance under the head equal to one diameter) within a tolerance zone having a diameter equivalent to six percent of the maximum width across flats, regardless of feature size.
- <sup>7</sup>Bearing surface shall be flat and washer faced. Diameter of bearing surface shall be equal to the maximum width across flats within a tolerance of minus 10 percent.
- Thickness of the washer face shall be not less than 0.015 inch (0.38 mm) nor greater than 0.025 inch (0.64 mm) for bolt sizes  $\frac{3}{4}$  inch (19 mm) and smaller and not less than 0.015 inch (0.38 mm) nor greater than 0.035 inch (0.89 mm) for sizes larger than  $\frac{3}{4}$  inch (19 mm).
- The plane of the bearing surface shall be perpendicular to the axis of the body within the full indicator movement (FIM) limits specified. Measurement of FIM shall be made as close to the periphery of the bearing surface as possible while the bolt is being held in a collet or other gripping device at a distance of one bolt diameter from the underside of the head.

**TABLE 22-IV-G—CHEMICAL REQUIREMENTS FOR GRADES O, A, B, C, D, DH AND 2, 2H NUTS**

GRADE OF NUT	COMPOSITION, percentage				
	Analysis	Carbon	Manganese, min.	Phosphorus, max.	Sulfur, max.
O, A, B, C	heat product	0.55 max	...	0.12	0.15 <sup>2</sup>
		0.58 max	...	0.13 <sup>1</sup>	...
D <sup>3</sup>	heat product	0.55 max	0.30	0.04	0.05
		0.58 max	0.27	0.048	0.058
DH <sup>3</sup> 2 and 2H	heat product ---	0.20-0.55	0.60	0.04	0.05
		0.18-0.58	0.57	0.48	0.08
		0.40 min.	---	0.040	0.05

<sup>1</sup>Acid bessemer steel only.

<sup>2</sup>Sulfur content may be 0.23 maximum for Grades O, A and B nuts if agreed between the manufacturer and the purchaser.

<sup>3</sup>For D and DH nuts, sulfur content may be 0.05 to 0.15 percent, in which, case manganese must be a minimum of 1.35 percent.

TABLE 22-IV-H—CHEMICAL REQUIREMENTS FOR GRADES C3 AND DH3 NUTS

ELEMENT	COMPOSITION, percentage							GRADE DH3 NUTS
	Classes for Grade C3 Nuts <sup>1</sup>							
	N	A	B	C	D	E	F	
Carbon:	...	0.33-0.40	0.38-0.48	0.15-0.25	0.14-0.25	0.20-0.25	0.20-0.25	0.20-0.53
Heat analysis	...	0.31-0.42	0.36-0.50	0.14-0.26	0.14-0.26	0.18-0.27	0.19-0.26	0.19-0.55
Product analysis								
Manganese:	...	0.90-1.20	0.70-0.90	0.80-1.35	0.40-1.20	0.60-1.00	0.90-1.20	0.40 max
Heat analysis	...	0.86-1.24	0.67-0.93	0.76-1.39	0.36-1.24	0.56-1.04	0.86-1.24	0.37 min
Product analysis								
Phosphorus:	0.07-0.15	0.040 max	0.06-0.12	0.035 max	0.040 max	0.040 max	0.040 max	0.046 max
Heat analysis	0.07-0.155	0.045 max	0.06-1.25	0.040 max	0.045 max	0.045 max	0.045 max	0.052 max
Product analysis								
Sulfur:	0.050 max	0.050 max	0.050 max	0.040 max	0.050 max	0.040 max	0.040 max	0.050 max
Heat analysis	0.055 max	0.055 max	0.055 max	0.045 max	0.055 max	0.045 max	0.045 max	0.055 max
Product analysis								
Silicon:	0.20-0.90	0.15-0.35	0.30-0.50	0.15-0.35	0.25-0.50	0.15-0.35	0.15-0.35	...
Heat analysis	0.15-0.95	0.13-0.37	0.25-0.55	0.13-0.37	0.20-0.55	0.13-0.37	0.13-0.37	...
Product analysis								
Copper:	0.25-0.55	0.25-0.45	0.25-0.40	0.20-0.50	0.30-0.50	0.30-0.60	0.25-0.40	0.20 min <sup>2</sup>
Heat analysis	0.22-0.58	0.22-0.48	0.17-0.43	0.17-0.53	0.27-0.53	0.27-0.63	0.17-0.43	0.17 min
Product analysis								
Nickel:	1.00 max	0.25-0.45	0.50-0.80	0.25-0.50	0.50-0.80	0.30-0.60	0.20-0.40	0.20 min
Heat analysis	1.03 max	0.22-0.48	0.47-0.83	0.22-0.53	0.47-0.83	0.27-0.63	0.17-0.43	0.17 min
Product analysis								
Chromium:	0.30-1.25	0.45-0.65	0.50-0.75	0.30-0.50	0.50-1.00	0.60-0.90	0.45-0.65	0.45 min
Heat analysis	0.25-1.30	0.42-0.68	0.47-0.83	0.27-0.53	0.45-1.05	0.55-0.95	0.42-0.68	0.42 min
Product analysis								
Vanadium:	...	...	...	0.20 min	...	...	...	.
Heat analysis	...	...	...	0.10 min	...	...	...	.
Product analysis								
Molybdenum:	...	...	0.06 max	...	0.10 max	...	...	0.15 min <sup>2</sup>
Heat analysis	...	...	0.07 max	...	0.11 max	...	...	0.14 min
Product analysis								
Titanium:	...	...	...	...	0.05 max	...	...	...
Heat analysis	...	...	...	...	...	...	...	...
Product analysis								

<sup>1</sup>C3 nuts may be made of any of the above-listed material classes. Selection of the class shall be at the option of the manufacturer.

<sup>2</sup>Nickel or molybdenum may be used.

TABLE 22-IV-1—MECHANICAL REQUIREMENTS

GRADE OF NUT	NOMINAL NUT SIZE (inches) × 25.4 for mm	STYLE OF NUT	PROOF LOAD STRESS, ksi <sup>1</sup>		HARDNESS			
			× 6.89 for MPa		Brinell		Rockwell	
			Non-Zinc-coated Nuts <sup>2</sup>	Zinc-coated Nuts <sup>2</sup>	min.	max.	min.	max.
Nuts with UNC, BUN, 6 UN and Coarser Pitch Threads								
O	1/4 to 1 1/2	square	69	52	103	302	B55	C32
A	1/4 to 1 1/2	square	90	68	116	302	B68	C32
O	1/4 to 1 1/2	hex	69	52	103	302	B55	C32
A	1/4 to 1 1/2	hex	90	68	116	302	B68	C32
B	1/4 to 1	hex	120	90	121	302	B69	C32
B	1 1/8 to 1 1/2	hex	105	79	121	302	B69	C32
D <sup>3</sup>	1/4 to 1 1/2	hex	135	135	159	352	B84	C38
DH <sup>4</sup>	1/4 to 1 1/2	hex	150	150	248	352	C24	C38
A	1/4 to 4	heavy hex	100	75	116	302	B68	C32
B	1/4 to 1	heavy hex	133	100	121	302	B69	C32
B	1 1/8 to 1 1/2	heavy hex	116	87	121	302	B69	C32
C <sup>3</sup>	1/4 to 4	heavy hex	144	144	143	352	B78	C38
C <sup>3</sup>	1/4 to 4	heavy hex	144	144	143	352	B78	C38
D <sup>3</sup>	1/4 to 4	heavy hex	150	150	159	352	B84	C38
DH <sup>4</sup>	1/4 to 4	heavy hex	175	175	248	352	C24	C38
DH <sup>3</sup>	1/4 to 4	heavy hex	175	175	248	352	C24	C38
A	1/4 to 1 1/2	hex thick	100	75	116	302	B68	C32
B	1/4 to 1	hex thick	133	100	121	302	B69	C32
B	1 1/8 to 1 1/2	hex thick	116	87	121	302	B69	C32
D <sup>3</sup>	1/4 to 1 1/2	hex thick	150	150	159	352	B84	C38
DH <sup>4</sup>	1/4 to 1 1/2	hex thick	175	175	248	352	C24	C38

(Continued)

TABLE 22-IV-1—MECHANICAL REQUIREMENTS—(Continued)

GRADE OF NUT	NOMINAL NUT SIZE (inches) × 25.4 for mm	STYLE OF NUT	PROOF LOAD STRESS, ksi <sup>1</sup>		HARDNESS			
			× 6.89 for MPa		Brinell		Rockwell	
			Non-Zinc-coated Nuts <sup>2</sup>	Zinc-coated Nuts <sup>2</sup>	min.	max.	min.	max.
Nuts with UNF, 12 UN and Finer Pitch Threads								
O	1/4 to 1 1/2	hex	65	49	103	302	B55	C32
A	1/4 to 1 1/2	hex	80	60	116	302	B68	C32
B	1/4 to 1	hex	109	82	121	302	B69	C32
B	1 1/8 to 1 1/2	hex	94	70	121	302	B69	C32
D <sup>3</sup>	1/4 to 1 1/2	hex	135	135	159	352	B84	C38
DH <sup>4</sup>	1/4 to 1 1/2	hex	150	150	248	352	C24	C38
A	1/4 to 4	heavy hex	90	68	116	302	B68	C32
B	1/4 to 1	heavy hex	120	90	121	302	B69	C32
B	1/4 to 1 1/2	heavy hex	105	79	121	302	B69	C32
D <sup>3</sup>	1/4 to 4	heavy hex	150	150	159	352	B84	C38
DH <sup>4</sup>	1/4 to 4	heavy hex	175	175	248	352	C24	C38
A	1/4 to 1 1/2	hex thick	90	68	116	302	B68	C32
B	1/4 to 1	hex thick	120	90	121	302	B69	C32
B	1 1/8 to 1 1/2	hex thick	105	79	121	302	B69	C32
D <sup>3</sup>	1/4 to 1 1/2	hex thick	150	150	159	352	B84	C38
DH <sup>4</sup>	1/4 to 1 1/2	hex thick	175	175	248	352	C24	C38

<sup>1</sup>To determine nut proof load in pounds (N), multiply the appropriate nut proof load stress by the tensile stress area of the thread.

<sup>2</sup>Non-zinc-coated nuts are nuts intended for use with externally threaded fasteners which have a plain (nonplated or noncoated) finish or have a plating or coating of insufficient thickness to necessitate overtapping the nut thread to provide assemblability. Zinc-coated nuts are nuts intended for use with externally threaded fasteners which are hot-dip zinc-coated, mechanically zinc-coated, or have a plating or coating of sufficient thickness to necessitate overlapping the nut thread to provide assemblability.

<sup>3</sup>Nuts made in accordance to the requirements of Grade 2 or 2H, and marked with their grade symbol are acceptable equivalents for Grades C and D nuts.

<sup>4</sup>Nuts made in accordance with the requirements of Grade 2H, and marked with its grade symbol are an acceptable equivalent for Grade DH nuts.

GRADE AND TYPE	COMPLETED NUTS			SAMPLE NUT AFTER TREATMENT	
	Brinell Hardness	Rockwell Hardness		Brinell Hardness, min.	Rockwell Hardness B Scale, min.
		C Scale	B Scale		
2	159 to 352	...	84 min.	159	84
2H	248 to 352	24 to 38	...	179	89

TABLE 22-IV-J—DIMENSIONS OF HEAVY HEX NUTS (Inches)<sup>1,2,3,4</sup>

NOMINAL SIZE	F		G	H	HEAVY HEX NUTS SPECIFIED PROOF LOAD <sup>5</sup>		
	WIDTH ACROSS FLATS <sup>6</sup>		WIDTH ACROSS CORNERS <sup>7</sup>		THICKNESS HEAVY HEX NUTS	UP TO 150,000 psi (1030 MPa)	150,000 psi (1030 MPa) AND GREATER
	× 25.4 for mm						
× 25.4 for mm	BASIC/MAX.	MIN.	MAX.	MIN.	MIN.	RUNOUT OF BEARING FACE, FIR MAX.	
1/4	0.500	0.488	0.577	0.556	0.218	0.017	0.011
5/16	0.562	0.546	0.650	0.622	0.280	0.020	0.012
3/8	0.688	0.669	0.794	0.763	0.341	0.021	0.014
7/16	0.750	0.728	0.866	0.830	0.403	0.022	0.015
1/2	<b>0.875</b>	<b>0.850</b>	<b>1.010</b>	<b>0.969</b>	<b>0.464</b>	0.023	0.016
9/16	0.938	0.909	1.083	1.037	0.526	0.024	0.017
5/8	<b>1.062</b>	<b>1.031</b>	<b>1.227</b>	<b>1.175</b>	<b>0.587</b>	0.025	0.018
3/4	<b>1.250</b>	<b>1.212</b>	<b>1.443</b>	<b>1.382</b>	<b>0.710</b>	0.027	0.020
7/8	<b>1.438</b>	<b>1.394</b>	<b>1.660</b>	<b>1.589</b>	<b>0.833</b>	0.029	0.022
1	<b>1.625</b>	<b>1.575</b>	<b>1.876</b>	<b>1.796</b>	<b>0.956</b>	0.031	0.024
1 1/8	<b>1.812</b>	<b>1.756</b>	<b>2.093</b>	<b>2.002</b>	<b>1.079</b>	0.033	0.027
1 1/4	<b>2.000</b>	<b>1.938</b>	<b>2.309</b>	<b>2.209</b>	<b>1.187</b>	0.035	0.030
1 3/8	<b>2.188</b>	<b>2.119</b>	<b>2.526</b>	<b>2.416</b>	<b>1.310</b>	0.038	0.033
1 1/2	<b>2.375</b>	<b>2.300</b>	<b>2.742</b>	<b>2.622</b>	<b>1.433</b>	0.041	0.036
1 5/8	2.562	2.481	2.959	2.828	1.556	0.044	0.038
1 3/4	<b>2.750</b>	<b>2.662</b>	<b>3.175</b>	<b>3.035</b>	<b>1.679</b>	0.048	0.041
1 7/8	2.938	2.844	3.392	3.242	1.802	0.051	0.044

(Continued)  
**TABLE 22-IV-J—DIMENSIONS OF HEAVY HEX NUTS (Inches)<sup>1,2,3,4</sup>—(Continued)**

NOMINAL SIZE	F		G	H	HEAVY HEX NUTS SPECIFIED PROOF LOAD <sup>5</sup>		
	WIDTH ACROSS FLATS <sup>6</sup>		WIDTH ACROSS CORNERS <sup>7</sup>		THICKNESS HEAVY HEX NUTS	UP TO 150,000 psi (1030 MPa)	150,000 psi (1030 MPa) AND GREATER
	× 25.4 for mm						
× 25.4 for mm	BASIC/MAX.	MIN.	MAX.	MIN.	MIN.	RUNOUT OF BEARING FACE, FIR MAX.	
2	<b>3.125</b>	<b>3.025</b>	<b>3.606</b>	<b>3.449</b>	<b>1.925</b>	0.055	0.047
2 <sup>1</sup> / <sub>4</sub>	3.500	3.388	4.041	3.862	2.155	0.061	0.052
2 <sup>1</sup> / <sub>2</sub>	3.875	3.750	4.474	4.275	2.401	0.068	0.058
2 <sup>3</sup> / <sub>4</sub>	4.250	4.112	4.907	4.688	2.647	0.074	0.064
3	4.625	4.475	5.340	5.102	2.893	0.081	0.070
3 <sup>1</sup> / <sub>4</sub>	5.000	4.838	5.774	5.515	3.124	0.087	0.075
3 <sup>1</sup> / <sub>2</sub>	5.375	5.200	6.207	5.928	3.370	0.094	0.081
3 <sup>3</sup> / <sub>4</sub>	5.750	5.562	6.640	6.341	3.616	0.100	0.087
4	6.125	5.925	7.073	6.755	3.862	0.107	0.093

<sup>1</sup>Unification: Bold type indicates products unified dimensionally with British and Canadian standards. Unification of fine thread products is limited to sizes 1 inch (25 mm) and under.

<sup>2</sup>Concentricity of tapped hole: Axis of tapped hole shall be concentric with axis of nut body within a tolerance equal to 3 percent (6 percent FIR) of the maximum width across flats.

<sup>3</sup>Countersink: Tapped hole shall be countersunk on the bearing face or faces. The maximum countersink diameter shall be the thread basic (nominal) major diameter plus 0.030 inch (0.76 mm) for <sup>3</sup>/<sub>8</sub> inch (9.5 mm) nominal size nuts and smaller and 1.08 times the basic major diameter for nuts larger than <sup>3</sup>/<sub>8</sub> inch (9.5 mm). No part of the threaded portion shall project beyond the bearing surface.

<sup>4</sup>Threads: Threads shall be unified coarse, fine or 8 thread series (UNC, UNF or 8 UN series), Class 2B.

<sup>5</sup>Tops and bearing surfaces of nuts: Nuts in sizes <sup>7</sup>/<sub>16</sub> inch (11 mm) nominal size and smaller shall be double chamfered. Larger size nuts shall be double chamfered or have washer faced bearing surface and chamfered top.

The diameter of chamfer circle on double chamfered nuts and diameter of washer face shall be within the limits of the maximum width across flats and 95 percent of the minimum width across flats.

The tops of washer faced nuts shall be flat and the diameter of chamfer circle shall be equal to the maximum width across flats within a tolerance of minus 15 percent.

The length of chamfer at hex corners shall be from 5 to 15 percent of the basic thread diameter. The surface of chamfer may be slightly convex or rounded.

Bearing surfaces shall be flat and perpendicular to the axis of the threaded hole within the FIR limits specified for the respective nut type and strength level.

<sup>6</sup>Width across flats: Maximum width across flats shall not be exceeded. No transverse section through the nut between 25 and 75 percent of the actual nut thickness as measured from the bearing surface shall be less than the minimum width across flats.

<sup>7</sup>Corner fill: A rounding or lack of fill at junction of hex corners with chamfer shall be permissible provided the width across corners is within specified limits at and beyond a distance equal to 17.5 percent of the basic thread diameter from the chamfered faces.

TABLE 22-IV-K—CHEMICAL REQUIREMENTS

ELEMENT	COMPOSITION, percentage	
	Carbon Steel Washers	Weathering Steel Washers
Phosphorus, max.		
Heat analysis	0.040	0.040
Product analysis	0.050	0.045
Sulfur, max.		
Heat analysis	0.050	0.050
Product analysis	0.060	0.055
Silicon		
Heat analysis	...	0.15–0.35
Product analysis	...	0.13–0.37
Chromium		
Heat analysis	...	0.45–0.65
Product analysis	...	0.42–0.68
Nickel		
Heat analysis	...	0.25–0.45
Product analysis	...	0.22–0.48
Copper		
Heat analysis	...	0.25–0.45
Product analysis	...	0.22–0.48

TABLE 22-IV-L—HARDENED CIRCULAR AND CLIPPED CIRCULAR WASHERS<sup>1</sup>

BOLT SIZE (Inches)	CIRCULAR AND CLIPPED CIRCULAR				CLIPPED
	Nominal Outside Diameter (O.D.) (Inches)	Normal Inside Diameter (I.D.) (Inches)	Thickness (T) (Inches)		Minimum Edge Distance (E) <sup>2</sup> (Inches)
			min.	max.	
× 25.4 for mm					
1/4	5/8	9/32	0.051	0.080	7/32
5/16	11/16	11/32	0.051	0.080	9/32
3/8	13/16	13/32	0.051	0.080	11/32
7/16	59/64	15/32	0.051	0.080	13/32
1/2	1 1/16	17/32	0.097	0.177	7/16
5/8	1 5/16	11/16	0.122	0.177	9/16
3/4	1 15/32	13/16	0.122	0.177	21/32
7/8	1 3/4	15/16	0.136	0.177	25/32
1	2	1 1/8	0.136	0.177	7/8
1 1/8	2 1/4	1 1/4	0.136	0.177	1
1 1/4	2 1/2	1 3/8	0.136	0.177	1 3/32
1 3/8	2 3/4	1 1/2	0.136	0.177	1 7/32
1 1/2	3	1 5/8	0.136	0.177	1 5/16
1 3/4	3 3/8	1 7/8	0.178 <sup>3</sup>	0.28 <sup>3</sup>	1 17/32
2	3 3/4	2 1/8	0.178 <sup>3</sup>	0.28 <sup>3</sup>	1 3/4
2 1/4	4	2 3/8	0.24 <sup>4</sup>	0.34 <sup>4</sup>	2
2 1/2	4 1/2	2 5/8	0.24 <sup>4</sup>	0.34 <sup>4</sup>	2 3/16
2 3/4	5	2 7/8	0.24 <sup>4</sup>	0.34 <sup>4</sup>	2 13/32
3	5 1/2	3 1/8	0.24 <sup>4</sup>	0.34 <sup>4</sup>	2 5/8
3 1/4	6	3 3/8	0.24 <sup>4</sup>	0.34 <sup>4</sup>	2 7/8
3 1/2	6 1/2	3 5/8	0.24 <sup>4</sup>	0.34 <sup>4</sup>	3 1/16
3 3/4	7	3 7/8	0.24 <sup>4</sup>	0.34 <sup>4</sup>	3 5/16
4	7 1/2	4 1/8	0.24 <sup>4</sup>	0.34 <sup>4</sup>	3 1/2

<sup>1</sup> Tolerances are as noted in Table 22-IV-N.

<sup>2</sup> Clipped edge, *E*, shall not be closer than 7/8 of the bolt diameter from the center of the washer.

<sup>3</sup> 3/16 inch (4.8 mm) nominal.

<sup>4</sup> 1/4 inch (6.4 mm) nominal.

TABLE 22-IV-M—HARDENED BEVELED WASHERS<sup>1</sup>

BOLT SIZE (Inches)	SQUARE BEVELED AND CLIPPED SQUARE BEVELED <sup>2</sup>			CLIPPED	
	Minimum Side Dimension (A) (Inches)	Nominal Inside Diameter (I.D.) (Inches)	Mean Thickness (T) (Inches)	Slope or Taper in Thickness	Nominal Edge Distance (E) <sup>3</sup> (Inches)
× 25.4 for mm					
1/2	1 3/4	17/32	5/16	1:6	7/16
5/8	1 3/4	11/16	5/16	1:6	9/16
3/4	1 3/4	13/16	5/16	1:6	21/32
7/8	1 3/4	15/16	5/16	1:6	25/32
1	1 3/4	1 1/8	5/16	1:6	7/8
1 1/8	2 1/4	1 1/4	5/16	1:6	1
1 1/4	2 1/4	1 3/8	5/16	1:6	1 3/32
1 3/8	2 1/4	1 1/2	5/16	1:6	1 7/32
1 1/2	2 1/4	1 5/8	5/16	1:6	1 5/16

<sup>1</sup>Tolerances are as noted in Table 22-IV-N.

<sup>2</sup>Rectangular beveled washers shall conform to the dimensions shown above, except that one side may be longer than that shown for the A dimension.

<sup>3</sup>Clipped edge E shall not be closer than 7/8 of the bolt diameter from the center of the washer.

TABLE 22-IV-N—WASHER DIMENSION TOLERANCES

	TO 1 1/2 IN. (38 mm) NOMINAL BOLT SIZE, INCL.	OVER 1 1/2 IN. (38 mm) NOMINAL BOLT SIZE, INCL.	OVER 3 TO 4 IN. (76 to 102 mm) NOMINAL BOLT SIZE, INCL.
	× 25.4 for mm		
Nominal diameter of hole, in.	-0, + 1/32	-0, + 1/16	-0, + 1/8
Nominal outside diameter, in.	± 1/32	± 1/16	± 1/8
Flatness: max. deviation from straightedge placed on cut side shall not exceed (in.)	0.010	0.015	0.032
Concentricity, in.: center of hole to outside diameter	0.030 FIR <sup>1</sup>	0.090 FIR <sup>1</sup>	0.250 FIR <sup>1</sup>
Burr shall not project above immediately adjacent washer surface more than (in.)	0.010	0.015	0.025

<sup>1</sup>Full indicator runout.

TABLE 22-IV-O—WEIGHT OF ZINC COATING FOR VARIOUS THICKNESSES OF BASE METAL

SPECIFIED BASE METAL THICKNESS (Inch)	MINIMUM WEIGHT OF ZINC COATING oz./ft. <sup>2</sup> OF SURFACE		EQUIVALENT THICKNESS OF ZINC COATING, mils <sup>1</sup>	
	× 304.8 for g/m <sup>2</sup>		× 0.0254 for mm	
× 25.4 for mm	Average of Specimen Tested	Any Individual Specimen or Computed Value <sup>2</sup>	Average of Specimen Tested	Any Individual Specimen or Computed Value
22 gauge (0.0299) to under $\frac{1}{16}$	1.10	0.85	1.87	1.45
$\frac{1}{16}$ to under $\frac{1}{8}$	1.50	1.25	2.55	2.13
$\frac{1}{8}$ to under $\frac{1}{4}$	2.00	1.80	3.40	3.06
$\frac{1}{4}$ or over	2.30	2.00	3.91	3.40
For wire in assemblies (diameters):				
Under $\frac{3}{16}$	1.00	0.75	1.70	1.28
$\frac{3}{16}$ to under $\frac{1}{4}$	1.50	1.25	2.55	2.13
$\frac{1}{4}$ or over	2.00	1.80	3.40	3.06

<sup>1</sup>Equivalent thickness of zinc coating is based upon mathematical calculations and does not take into consideration the iron content of the coating.

<sup>2</sup>Computed average of at least five spot measurements.

**Division V—DESIGN STANDARD FOR SPECIFICATION FOR THE DESIGN OF  
COLD-FORMED STEEL STRUCTURAL MEMBERS****Based on Specification for Design of Cold-formed Steel Structural Members, of  
the American Iron and Steel Institute (1986 with December 1989 Addendum)**

Section 2229 of this division contains the exceptions to the referenced specification. Section 2230 of this division, "Specification for the Design of Cold-formed Steel Structural Members," is reproduced with permission of the publisher.

**SECTION 2229 — AMENDMENTS**

The American Iron and Steel Institute (AISI) specification adopted by this standard applies to the design of cold-formed steel structural members except as modified by this part. Where other codes, standards or specifications are referred to in this standard, they are to be considered as only an indication of an acceptable method or material that can be used with the approval of the building official.

**1. Sections A4.1 and A4.2 are deleted.**

**2. Section A4.4, modify as follows:** Where load combinations specified by Section 1603.6 include wind or earthquake loads, the resulting forces may be multiplied by 0.75 for strength determination. Such reduction shall not be allowed in combination with reductions in accordance with Section 1603.5.

**3. Section A6.** Whenever reference is made to American Iron and Steel Code "Specification for the Design, Fabrication and Erection of Structural Steel Buildings," such reference shall be taken as Division IX.

Whenever reference is made to the Research Council for Structural Connections "Specifications for Structural Joints Using ASTM A 325 or A 490 Bolts," such reference shall be taken as Division IV.

Whenever reference is made to the Steel Joist Institute "Standard Specifications Load Tables and Weight Tables for Steel Joists and Joist Girders," such reference shall be taken as Division III.

**SECTION 2230 — ADOPTION**

Reproduced with permission from the American Iron and Steel Institute, 1133 15th Street, N.W., Washington, DC 20005. Persons desiring to reprint in whole or in part any portion of this specification must secure permission from the American Iron and Steel Institute.

**SPECIFICATION FOR THE DESIGN OF COLD-FORMED  
STEEL STRUCTURAL MEMBERS****AUGUST 19, 1986, EDITION****WITH****DECEMBER 11, 1989, ADDENDUM****AMERICAN IRON AND STEEL INSTITUTE****1133 15th STREET, NW****WASHINGTON, DC 20005-2701**

This publication is for general information only. The information in it should not be used without first securing competent advice with respect to its suitability for any given application. The publication of the information is not intended as a representation or warranty on the part of American Iron and Steel Institute—or any other person named herein—that the information is suitable for any general or particular use or of freedom from infringement of any patent or patents. Anyone making use of the information assumes all liability arising from such use.

1st Printing—January, 1991  
Produced by Computerized Structural Design, Inc.  
Milwaukee, Wisconsin  
Copyright American Iron and Steel Institute 1986, 1989

**TABLE OF CONTENTS**  
**SPECIFICATION FOR THE DESIGN OF**  
**COLD-FORMED STEEL STRUCTURAL MEMBERS**  
**AUGUST 19, 1986, EDITION**  
**WITH**  
**DECEMBER 11, 1989, ADDENDUM**

**SYMBOLS AND DEFINITIONS**

**A. GENERAL PROVISIONS**

- A1 Limits of Applicability and Terms
  - A1.1 Scope and Limits of Applicability
  - A1.2 Terms
  - A1.3 Units of Symbols and Terms
- A2 Non-Conforming Shapes and Construction
- A3 Material
  - A3.1 Applicable Steels
  - A3.2 Other Steels
  - A3.3 Ductility
  - A3.4 Delivered Minimum Thickness
- A4 Loads
  - A4.1 Dead Load (Deleted per Part I)
  - A4.2 Live Load (Deleted per Part I)
  - A4.3 Impact Load
  - A4.4 Wind or Earthquake Loads (Modified per Part I)
  - A4.5 Ponding
- A5 Structural Analysis and Design
  - A5.1 Design Basis
  - A5.2 Yield Point and Strength Increase from Cold Work of Forming
    - A5.2.1 Yield Point
    - A5.2.2 Strength Increase from Cold Work of Forming
  - A5.3 Serviceability and Durability
- A6 Reference Documents (Modified per Part I)

**B. ELEMENTS**

- B1 Dimensional Limits and Considerations
  - B1.1 Flange Flat-Width-to-Thickness Considerations
  - B1.2 Maximum Web Depth-to-Thickness Ratio
- B2 Effective Widths of Stiffened Elements
  - B2.1 Uniformly Compressed Stiffened Elements
  - B2.2 Uniformly Compressed Stiffened Elements with Circular Holes
  - B2.3 Effective Width of Webs and Stiffened Elements with Stress Gradient
- B3 Effective Widths of Unstiffened Elements
  - B3.1 Uniformly Compressed Unstiffened Elements
  - B3.2 Unstiffened Elements and Edge Stiffeners with Stress Gradient
- B4 Effective Widths of Elements with an Edge Stiffener or One Intermediate Stiffener
  - B4.1 Uniformly Compressed Elements with an Intermediate Stiffener
  - B4.2 Uniformly Compressed Elements with an Edge Stiffener
- B5 Effective Widths of Edge Stiffened Elements with Intermediate Stiffeners or Stiffened Elements with More Than One Intermediate Stiffener

- B6 Stiffeners
  - B6.1 Transverse Stiffeners
  - B6.2 Shear Stiffeners
  - B6.3 Non-Conforming Stiffeners

**C. MEMBERS**

- C1 Properties of Sections
- C2 Tension Members
- C3 Flexural Members
  - C3.1 Strength for Bending Only
    - C3.1.1 Nominal Section Strength
    - C3.1.2 Lateral Buckling Strength
    - C3.1.3 Beams Having One Flange Through-Fastened to Deck or Sheathing
  - C3.2 Strength for Shear Only
  - C3.3 Strength for Combined Bending and Shear
  - C3.4 Web Crippling Strength
  - C3.5 Combined Bending and Web Crippling Strength
- C4 Concentrically Loaded Compression Members
  - C4.1 Sections Not Subject to Torsional or Torsional-Flexural Buckling
  - C4.2 Doubly- or Singly-Symmetric Sections Subject to Torsional or Torsional-Flexural Buckling
  - C4.3 Nonsymmetric Sections
- C5 Combined Axial Load and Bending
- C6 Cylindrical Tubular Members
  - C6.1 Bending
  - C6.2 Compression
  - C6.3 Combined Bending and Compression

**D. STRUCTURAL ASSEMBLIES**

- D1 Built-Up Sections
  - D1.1 I—Sections Composed of Two Channels
  - D1.2 Spacing of Connections in Compression Elements
- D2 Mixed Systems
- D3 Lateral Bracing
  - D3.1 Symmetrical Beams and Columns
  - D3.2 Channel-Section and Z-Section Beams
    - D3.2.1 Anchorage of Bracing for Roof Systems Under Gravity Load With Top Flange Connected to Sheathing
    - D3.2.2 Neither Flange Connected to Sheathing
  - D3.3 Laterally Unbraced Box Beams
- D4 Wall Studs and Wall Stud Assemblies
  - D4.1 Wall Studs in Compression
  - D4.2 Wall Studs in Bending
  - D4.3 Wall Studs with Combined Axial Load and Bending
- D5 Floor, Roof or Wall Steel Diaphragm Construction

**E. CONNECTIONS AND JOINTS**

- E1 General Provisions
- E2 Welded Connections
  - E2.1 Groove Welds in Butt Joints
  - E2.2 Arc Spot Welds
  - E2.3 Arc Seam Welds
  - E2.4 Fillet Welds
  - E2.5 Flare Groove Welds
  - E2.6 Resistance Welds
- E3 Bolted Connections

- E3.1 Spacing and Edge Distance
- E3.2 Tension in Connected Part
- E3.3 Bearing
- E3.4 Shear and Tension in Bolts
- E4 Shear Rupture
- E5 Connections to Other Materials
  - E5.1 Bearing
  - E5.2 Tension
  - E5.3 Shear

**F. TESTS FOR SPECIAL CASES**

- F1 Tests for Determining Structural Performance
- F2 Tests for Confirming Structural Performance
- F3 Tests for Determining Mechanical Properties
  - F3.1 Full Section
  - F3.2 Flat Elements of Formed Sections
  - F3.3 Virgin Steel

**SYMBOLS AND DEFINITIONS**

Symbol	Definition	Section
A	Full unreduced cross-sectional area of the member	C3.1.1, C3.1.2, C4, C6.2, D4.1
A	Contact area	E5.1
A <sub>b</sub>	b <sub>1</sub> t + A <sub>s</sub> , for transverse stiffeners at interior support and under concentrated load, and b <sub>2</sub> t + A <sub>s</sub> , for transverse stiffeners at end support	B6.1, E3.4
A <sub>c</sub>	18t <sup>2</sup> + A <sub>s</sub> , for transverse stiffeners at interior support and under concentrated load, and 10t <sup>2</sup> + A <sub>s</sub> , for transverse stiffeners at end support	B6.1
A <sub>e</sub>	Effective area at the stress F <sub>n</sub>	C4, C6.2, D4.1
A <sub>n</sub>	Net area of cross section	C2, E3.2
A <sub>s</sub>	Cross-sectional area of transverse stiffeners	B4, B4.1, B4.2, B6.1
A' <sub>s</sub>	Effective area of stiffener	B4, B4.1, B4.2
A <sub>st</sub>	Gross area of shear stiffener	B6.2
A <sub>wn</sub>	Net web area	E4
A <sub>1</sub>	Bearing area	E5.1
A <sub>2</sub>	Full cross-sectional area of concrete support	E5.1
a	Shear panel length of the unreinforced web element. For a reinforced web element, the distance between transverse stiffeners	B6.2, C3.2, D3.2
a	Lateral deflection of the compression flange at assumed load, q	C3.1.3
a	Length of bracing interval	D3.2
B	Stud spacing	D4, D4.1
B <sub>c</sub>	Term for determining the tensile yield point of corners	A5.2.2
b	Effective design width of compression element	B2.1, B2.2, B2.3, B3.1, B3.2, B4.1, B4.2, B5
b	Overall width of compression flange, C or Z	D3.2.1

$b_d$	Effective widths for deflection calculations	B2.1, B2.2
$b_e$	Effective design width of sub-element or element	A1.2, E2.3, B5
$b_o$	See Figure B4.1	B4, B4.1, B5
$C$	For flexural members, ratio of the total corner cross-sectional area of the controlling flange to the full cross-sectional area of the controlling flange	A5.2.2
$C_b$	Bending coefficient dependent on moment gradient	C3.1.1
$C_m$	End moment coefficient in interaction formula	C5
$C_{ms}$	Coefficient for lateral bracing of C- and Z-section	D3.2.1
$C_{mx}, C_{my}$	End moment coefficient in interaction formula	C5
$C_s$	Coefficient for lateral torsional buckling	C3.1.1
$C_{TF}$	End moment coefficient in interaction formula	C3.1.1
$C_{th}, C_{tr}$	Coefficient for lateral bracing of C- and Z-sections	D3.2.1.
$C_v$	Shear stiffener coefficient	B6.2
$C_w$	Torsional warping constant of the cross-section	C3.1.1
$C_y$	Compression strain factor	C3.1.1
$C_o$	Initial column imperfection	D4.1
$C_1$	Term used to compute shear strain in wall board	B4, B4.1, D4.2
$C_2$	Coefficient as defined in Figure B4-2	B4, B4.2
$c$	Distance from the neutral axis to the extreme fiber of untwisted section	C3.1.3
$c_f$	Amount of curling	B1.1b
$D$	Outside diameter of cylindrical tube	C6.1, C6.2, D4.2
$D$	Dead load, includes weight of the test specimen	F1
$D$	Overall depth of lip	B1.1, B4, D1.1
$D$	Shear stiffener coefficient	B6.2
$D_o$	Initial column imperfection	D4.1
$d$	Depth of section	B1.1b, B4, C3.1.1, C3.1.3, D1.1, D3.2.1, D4, D4.1, E3.4
$d$	Width of arc seam weld	E2.3
$d$	Visible diameter of outer surface of arc spot weld	E2.2
$d$	Diameter of bolt	E3, E3.1, E3.2
$d_a$	Average diameter of the arc spot weld at mid-thickness of $t$	E2.2
$d_a$	Average width of seam weld	E2.3
$d_e$	Effective diameter of fused area	E2.2
$d_e$	Effective width of arc seam weld at fused surfaces	E2, E2.3
$d_h$	Diameter of standard hole	B2.2, E3.1, E4
$d_s$	Reduced effective width of stiffener	B4, B4.2
$d'_s$	Actual effective width of stiffener	B4, B4.2

$d_{wc}$	Coped web depth	E4
E	Modulus of elasticity of steel (29,500 ksi) (203 395 MPa)	B1.1b, B2.1, B6.1, C3.1.1, C3.1.3, C3.2., C3.5.2, C4, C4.1, C5, C6.1, D1.2, D4.1, D4.2, E2.2
$E_o$	Initial column imperfection; a measure of the initial twist of the stud from the initial, ideal, unbuckled location	D4.1
$E_t$	Term used to compute shear strain in wallboard	D4.1
$E'$	Inelastic modulus of elasticity	D4.1
$e_{min}$	Minimum allowable distance measured in the line of force from the centerline of a weld to the nearest edge of an adjacent weld or to the end of the connected part which the force is directed	E2.2
$e_{min}$	The distance $e$ measured in the line of force from the center of a standard hole to the nearest edge of an adjacent hole or to the end of the connected part toward which the force is directed	E3.1
$e_y$	Yield strain = $F_y/E$	C3.1.1
$F_D$	Dead load factor	F1
$F_e$	Elastic buckling stress	C4, C4.1, C4.2, C4.3, C6.2, D4.1
$F_L$	Live load factor	F1
$F_n$	Nominal buckling stress	C4, C6.2, D4.2
$F_p$	Allowable bearing stress	E3.3, E5.1
$F_{sy}$	Yield point as specified in Sections A3.1 or A3.2	A3.3.2, E2.2, E3.1, E3.2
$F_t$	Nominal tension stress limit on net section	E3.2, E3.4
$F'_t$	Allowable tension stress for bolts subject to combination of shear and tension	E3.4
$F_u$	Tensile strength as specified in Sections A3.1 or A3.2, or as reduced for low ductility steel	A3.3, A3.3.2, E2.2, E2.3, E2.4, E2.5, E3.1, E3.2, E3.3, E4
$F_{uv}$	Ultimate tensile strength of virgin steel specified by Section A3 or established in accordance with Section F3.3	A5.2.2, E2.2
$F_v$	Allowable shear stress on the gross area of a bolt	E3.4
$F_{wy}$	Yield point for design of transverse stiffeners	B6.1
$F_{xx}$	Strength level designation in AWS electrode classification	E2.2, E2.3, E2.4, E2.5
$F_y$	Yield point used for design, not to exceed the specified yield point or established in accordance with Section F3, or as increased for cold work of forming in Section A5.5.2 or as reduced for low ductility steels in Section A3.3.2	A1.2, A3.3, A5.2.1, A5.2.2, B2.1, B5, B6.1, C2, C3.1, C3.1.1, C3.1.3, C3.2, C3.5.2, C4, C6.1, C6.2,

		D1.2, D4, D4.2, E2
$F_{ya}$	Average yield point of section	A5.2.2
$F_{yc}$	Tensile yield point of corners	A5.2.2
$F_{yf}$	Weighted average tensile yield point of the flat portions	F3.2, A5.2.2
$F_{ys}$	Yield point of stiffener steel	B6.1
$F_{yv}$	Tensile yield point of virgin steel specified by Section A3 or established in accordance with Section F3.3	A5.2.2
$f$	Stress in the compression element computed on the basis of the effective design width	B2.1, B2.2, B3.2, B4, B4.1
$f_{av}$	Average computed stress in the full, unreduced flange width	B1.1b
$f_b$	Maximum bending stress equal to the bending moment divided by appropriate section modulus of member	C3.1.3
$f_c$	Computed stress at design load in the cover plate or sheet	D1.2
$f'_c$	Specified compression stress of concrete	E5.1
$f_d$	Computed compressive stress in the element being considered. Calculations are based on the effective section at the load for which deflections are determined	B2.1, B2.2, B3.1, B4.1, B4.2
$f_{d1}, f_{d2}$	Computed stresses $f_1$ and $f_2$ as shown in Figure B2.3-1. Calculations are based on the effective section at the load for which deflections are determined	B2.3
$f_{d3}$	Computed stress $f_3$ in edge stiffener, as shown in Figure B4-2. Calculations are based on the effective section at the load for which deflections are determined	B3.2
$f_t$	The computed maximum compressive stress due to twisting and lateral bending	C3.1.3
$f_v$	Computed shear stress on a bolt	E4
$f_1, f_2$	Web stresses defined by Figure B2.3-1	B2.3
$f_3$	Edge stiffener stress defined by Figure B4.2	B3.2
$G$	Shear modulus for steel = 11,300 ksi (77 857 MPa)	C3.1.1, D4.1
$G'$	Inelastic shear modulus	D4.1
$g$	Vertical distance between two rows of connections nearest to the top and bottom flanges	D1.1
$h$	Depth of flat portion of web measured along the plane of web	B1.2, B6.2, C3.2, C3.4, C3.5.2
$I_a$	Adequate moment of inertia of stiffener so that each component will behave as a stiffened element	B1.1, B4, B4.1, B4.2
$I_b$	Moment of inertia of the full unreduced section about the bending axis	C5
$I_o$	Moment of inertia of effective section about its major axis	C3.1.3

$I_s$	Actual moment of inertia of the full stiffener about its own centroidal axis parallel to the element to be stiffened	B1.1, B4, B4.1, B4.2, B5
$I_{sf}$	Moment of inertia of the full area of the multiple stiffened element, including the intermediate stiffeners, about its own centroidal axis parallel to the element to be stiffened	B5
$I_{yc}$	Moment of inertia of the compression portion of a section about the centroidal axis of the entire section parallel to the web, using the full unreduced section	C3.1.2
$I_x, I_y$	Moment of inertia of full section about principal axis	D3.2.2, D1.1
$I_{xy}$	Product of inertia of full section about major and minor centroidal axes	D3.2.2, D4.1
$J$	St. Venant torsion constant	C3.1.1
$j$	Section property for torsional-flexural buckling	C3.1.1
$K$	Effective length factor	C3.1.3, C4, C4.1, C5
$K'$	A constant	D3.2.2
$K_b$	Effective length factor in the plane of bending	C5
$K_t$	Effective length factor for torsion	C3.1.2
$K_x$	Effective length factor for bending about x-axis	C3.1.2
$K_y$	Effective length factor for bending about y-axis	C3.1.2
$k$	Plate buckling coefficient	B2.1, B2.3, B3.1, B3.2, B4, B4.1, B4.2
$k_v$	Shear buckling coefficient	B6.2, C3.2
$L$	Full span for simple beams, distance between inflection points for continuous beams, twice the length of cantilever beams	B1.1c, D3.2.1
$L$	Length of seam weld not including the circular ends	E2.3
$L$	Length of fillet weld	E2.4, E2.5
$L$	Unbraced length of member	C3.1.2, C3.1.3, C4.1, D1.1, D4, D4.1
$L$	Live load	F1
$L_a$	Length of the portion of the span between supports where the flange that is not connected to the sheathing is in compression	C3.1.3
$L_{st}$	Length of transverse stiffener	B6.1
$L_t$	Unbraced length of compression member for torsion	C3.1.1
$L_x$	Unbraced length of compression member for bending about x-axis	C3.1.1
$L_y$	Unbraced length of compression member for bending about y-axis	C3.1.1
$M$	Applied bending moment	C3.3, C3.5.1, C3.5.2

$M_a$	Allowable bending moment permitted if bending stress only exists	C3.1, C3.3, C3.5.1, C3.5.2, C6.1
$M_{ax}, M_{ay}$	Allowable moments about the centroidal axes determined in accordance with Section C3	C5
$M_{axo}, M_{ayo}$	Allowable moments about the centroidal axes determined in accordance with Section 3.1 excluding the provisions of Section 3.1.2	C3.3, C3.5
$M_c$	Critical moment	C3.1.2
$M_e$	Elastic critical moment	C3.1.2
$M_n$	Nominal moment strength	C3.1, C3.1.1, C3.1.2, C3.1.3, C6.1
$M_x, M_y$	Applied moments about the centroidal axes determined in accordance with Section C3	C5
$M_y$	Moment causing a maximum strain of $e_y$	B2.1, C3.1
$M_1$	Smaller end moment	C3.1.1, C5
$M_2$	Larger end moment	C3.1.1, C5
$m$	Distance from the shear center of one channel to the mid-plane of its web	D3.2.2, D1.1
$m$	$0.192 (F_{uv}/F_{yv}) - 0.068$	A5.2.2
$N$	Actual length of bearing	D3.6
$n$	Number of holes	E4
$n_p$	Number of parallel purlin lines	D3.2.1
$P$	Concentrated load or reaction	C3.5
$P$	Applied axial load	C5, D4.1
$P$	Force transmitted by bolt	E3, E3.1
$P$	Force transmitted by weld	E2, E2.2
$P_a$	Allowable concentrated load or reaction for one transverse stiffener	B6.1
$P_{ao}$	Allowable axial load determined in accordance with Section C4 for $L = 0$	C5
$P_L$	Force to be resisted by intermediate beam brace	B3.2.2
$P_n$	Nominal axial strength of member	C4, C6.2
$P_n$	Nominal strength of connection component	E2, E2.2, E2.3, E2.4, E2.5
$\bar{Q}$	Design shear rigidity for sheathing on both sides of the wall assembly	D4.1
$q$	Uniformly distributed load in the plane of the web	C3.1.3, D1.1
$q_w$	Allowable uniform load	C3.1.3
$\bar{q}$	Design shear rigidity for sheathing per inch of stud spacing	D4.1
$\bar{q}_o$	Factor used to determine design shear rigidity	D4.1
$q_u$	Maximum uniformly distributed load in the plane of the web	C3.1.3
$R$	Inside bend radius	A5.2.2, C3.4
$R$	Reduction Factor	C3.1.3
$R$	Coefficient	C4, C6.2
$R$	Required load-carrying capacity	F1

r	Radius of gyration of full unreduced cross section	C3.1.1, C4, C4.1
r	Force transmitted by the bolt or bolts at the section considered, divided by the tension force in member at that section	E3.2
r <sub>cy</sub>	Radius of gyration of one channel about its centroidal axis parallel to web	D1.1
r <sub>o</sub>	Polar radius of gyration of cross section about the shear center	C3.1.1, C4.2, D4.1
r <sub>x</sub> , r <sub>y</sub>	Radius of gyration of cross section about centroidal principal axis	C3.1.1
r <sub>I</sub>	Radius of gyration of I-section about the axis perpendicular to the direction in which buckling would occur for the given conditions of end support and intermediate bracing	D1.1
S	$1.28 \sqrt{E/f}$	B4, B4.1
S <sub>a</sub>	In-plane load-carrying capacity for diaphragms	D5
S <sub>c</sub>	Elastic section modulus of the effective section calculated at a stress M <sub>c</sub> /S <sub>f</sub> in the extreme compression fiber	C3.1.1, C3.1.2, C4
S <sub>e</sub>	Elastic section modulus of the effective section calculated with extreme compression or tension fiber at F <sub>y</sub>	C3.1.1, C3.1.3
S <sub>f</sub>	Elastic section modulus of full unreduced section for the extreme compression fiber	C3.1.1, C3.1.2, C6.1
S <sub>f</sub>	Nominal diaphragm shear strength	D5
s <sub>max</sub>	Maximum permissible longitudinal spacing of welds or other connectors joining two channels to form an I-section	D1.1
s	Fastener spacing	D1.2, D4.1
s	Spacing in line of stress of welds, rivets, or bolts connecting a compression coverplate or sheet to a non-integral stiffener or other element	E3.2
s	Weld spacing	D1.1
T <sub>a</sub>	Allowable tensile strength	C2
T <sub>n</sub>	Nominal tensile strength	C2
T <sub>s</sub>	Strength of connection in tension	D1.1
t	Base steel thickness of any element or section	A1.2, A3.4, A5.2.1, B1.1, B1.1b, B1.2, B2.1, B4, B4.1, B4.2, B5, B6.1, C3.1.1., C3.1.3, C3.2, C3.4, C3.5.2, C4, C6.1, C6.2, D1.2, D4, E2.4, E2.5
t	Total thickness of the two welded sheets	E2.2
t	Thickness of thinnest connected part	E2.2, E3.1, E4
t <sub>s</sub>	Equivalent thickness of a multiple-stiffened element	B5, B6.1

$t_w$	Effective throat of weld	E2.4, E2.5
$V$	Actual shear force	C3.3
$V_a$	Allowable shear force	B6.2, C3.2, C3.3
$W$	Total load supported by the purlin lines between adjacent supports, lbs.	D3.2.1.
$w$	Flat width of element exclusive of radii	A1.2, E1.1, B2.1, E2.2, B3.1, E4, B4.1, B4.2, E5, C3.1.1., C3.1.3, C4, D1.2
$w$	Flat width of the beam flange which contacts the bearing plate	C3.5
$w_f$	Width of flange projection beyond the web or half the distance between webs for box- or U-type sections	B1.1
$w_f$	Projection of flanges from inside face of web	D1.1
$w_1, w_2$	Leg on weld	E2.4
$x$	Distance from concentrated load to brace	D3.2
$x_o$	Distance from shear center to centroid along the principal x-axis	C3.1.1, C4.2, D4.1
$Y$	Yield point of web steel divided by yield point of stiffener steel	B6.2
$1/\alpha_x$	Magnification factors	C5
$1/\alpha_y$		
$\beta$	Coefficient	C4.2, D4.1
$\gamma$	Actual shear strain in the sheathing	D4.1
$\bar{\gamma}$	Permissible shear strain of the sheathing	D4.1
$\theta$	Angle between web and bearing surface $>45^\circ$ but not more than $90^\circ$	C3.4
$\theta$	Angle between the vertical and the plane of the web of the Z-section, degrees	D3.2.1
$\sigma$	Stress related to shear strain in sheathing	D4.1
$\sigma_{CR}$	Theoretical elastic buckling stress	D4.1
$\sigma_t$	Torsional buckling stress	C3.1.1, C4.2, D4.1
$\rho$	Reduction factor	B2.1
$\lambda, \lambda_c$	Slenderness factors	B2.1, C3.5
$\psi$	$f_2/f_1$	B2.3
$\Omega_b$	Factor of safety for bearing	E3.3
$\Omega_c$	Factor of safety for axial compression	B6.1, C4, C5, C6.2, D4.1
$\Omega_e$	Factor of safety for sheet tearing	E2.2, E3.1
$\Omega_f$	Factor of safety for flexure	C3.1, C6.1
$\Omega_s$	Factor of safety for diaphragm shear	D5
$\Omega_{st}$	Factor of safety for end crushing of transverse stiffener	B6.1
$\Omega_t$	Factor of safety for tension on net section	C2, E3.2
$\Omega_v$	Factor of safety for shear rupture	E4
$\Omega_w$	Factor of safety for welded connections	E2

## A. GENERAL PROVISIONS

### A1 Limits of Applicability and Terms

#### A1.1 Scope and Limits of Applicability

This Specification shall apply to the design of structural members cold-formed to shape from carbon or low-alloy steel sheet, strip, plate or bar not more than one inch in thickness and used for load-carrying purposes in buildings. It may also be used for structures other than buildings provided appropriate allowances are made for dynamic effects. Appendices to this Specification shall be considered as integral parts of the Specification.

#### A1.2 Terms

Where the following terms appear in this Specification they shall have the meaning herein indicated:

- (a) *Stiffened or Partially Stiffened Compression Elements.* A stiffened or partially stiffened compression element is a flat compression element (i.e., a plane compression flange of a flexural member or a plane web or flange of a compression member) of which both edges parallel to the direction of stress are stiffened either by a web, flange, stiffening lip, intermediate stiffener, or the like.
- (b) *Unstiffened Compression Elements.* An unstiffened compression element is a flat compression element which is stiffened at only one edge parallel to the direction of stress.
- (c) *Multiple-Stiffened Elements.* A multiple-stiffened element is an element that is stiffened between webs, or between a web and a stiffened edge, by means of intermediate stiffeners which are parallel to the direction of stress. A *sub-element* is the portion between adjacent stiffeners or between web and intermediate stiffener or between edge and intermediate stiffener.
- (d) *Flat-Width-to-Thickness Ratio.* The flat width of an element measured along its plane, divided by its thickness.
- (e) *Effective Design Width.* Where the flat width of an element is reduced for design purposes, the reduced design width is termed the effective width or effective design width.
- (f) *Thickness.* The thickness,  $t$ , of any element or section shall be the base steel thickness, exclusive of coatings.
- (g) *Torsional-Flexural Buckling.* Torsional-flexural buckling is a mode of buckling in which compression members can bend and twist simultaneously.
- (h) *Point-Symmetric Section.* A point-symmetric section is a section symmetrical about a point (centroid) such as a Z-section having equal flanges.
- (i) *Yield Point.* Yield point,  $F_y$  or  $F_{sy}$ , as used in this Specification shall mean yield point or yield strength.
- (j) *Stress.* Stress as used in this Specification means force per unit area.
- (k) *Confirmatory Test.* A confirmatory test is a test made, when desired, on members, connections, and assemblies designed according to the provisions of Sections A through E of this Specification or its specific references, in order to compare actual versus calculated performance.
- (l) *Performance Test.* A performance test is a test made on structural members, connections, and assemblies whose performance cannot be determined by the provisions of Sections A through E of this Specification or its specific references.
- (m) *Virgin Steel.* Virgin steel refers to steel as received from the steel producer or warehouse before being cold worked as a result of fabricating operations.
- (n) *Virgin Steel Properties.* Virgin steel properties refer to mechanical properties of virgin steel such as yield point, tensile strength, and elongation.

- (o) *Specified Minimum Yield Point.* The specified minimum yield point is the lower limit of yield point which must be equaled or exceeded in a specification test to qualify a lot of steel for use in a cold-formed steel structural member designed at that yield point.
- (p) *Cold-Formed Steel Structural Members.* Cold-formed steel structural members are shapes which are manufactured by press-braking blanks sheared from sheets, cut lengths of coils or plates, or by roll forming cold- or hot-rolled coils or sheets; both forming operations being performed at ambient room temperature, that is, without manifest addition of heat such as would be required for hot forming.

### A1.3 Units of Symbols and Terms

The Specification is written so that any compatible system of units may be used except where explicitly stated otherwise in the text of these provisions.

### A2 Non-Conforming Shapes and Construction

The provisions of the Specification are not intended to prevent the use of alternate shapes or constructions not specifically prescribed herein. Such alternates shall meet the provisions of Section F of the Specification and be approved by the appropriate building code authority.

## A3 Material

### A3.1 Applicable Steels

This Specification requires the use of steel of structural quality as defined in general by the provisions of the following specifications of the American Society for Testing and Materials:

A36/A36M, A242/A242M, A441M, A446/A446M, A500, A529/A529M, A570/A570M, A572/A572M, A588/A588M, A606, A607, A611, A715 and A792.

### A3.2 Other Steels

The listing in Section A3.1 does not exclude the use of steel up to and including one inch in thickness ordered or produced to other than the listed specifications provided such steel conforms to the chemical and mechanical requirements of one of the listed specifications or other published specification which establishes its properties and suitability, and provided it is subjected by either the producer or the purchaser to analyses, tests and other controls to the extent and in the manner prescribed by one of the listed specifications and Section A3.3.

### A3.3 Ductility

Steels not listed in Section A3.1 and used for structural members and connections shall comply with one of the following ductility requirements:

**A3.3.1** The ratio of tensile strength to yield point shall not be less than 1.08, and the total elongation shall not be less than 10 percent for a two-inch (51 mm) gage length or 7 percent for an eight-inch (203 mm) gage length standard specimen tested in accordance with ASTM A370. If these requirements cannot be met, the following criteria shall be satisfied: (1) local elongation in a  $1/2$  inch (12.7 mm) gage length across the fracture shall not be less than 20%, (2) uniform elongation outside the fracture shall not be less than 3%. When material ductility is determined on the basis of the local and uniform elongation criteria, the use of such material is restricted to the design of purlins and girts\* in accordance with Sections C3.1.1(a), C3.1.2, and C3.1.3. For purlins and girts subject to combined axial load and bending moment (Section C5),  $P/P_a$  shall not exceed 0.15. The provisions of Chapters B through E of this Specification are limited to steels conforming to these requirements.

**A3.3.2** Steels conforming to A446 Grade E and A611 Grade E and other steels which do not meet the provisions of Section A3.3.1 may be used for particular configurations provided (1) the yield strength,  $F_y$ , used for design in Chapters B, C and D is taken as 75 percent of the specified minimum yield point or 60 ksi (413.7 MPa), whichever is less and (2) the tensile strength,  $F_u$ , used for design

\* Horizontal structural members which support roof deck or panel covering and applied loads principally by bending.

in Chapter E is taken as 75 percent of the specified minimum tensile stress or 62 ksi (427.5 MPa), whichever is less. Alternatively, the suitability of such steels for the configuration shall be demonstrated by load tests in accordance with Section F1. Allowable loads based on these tests shall not exceed the loads calculated according to Chapters B through E, using the specified minimum yield point,  $F_{sy}$ , for  $F_y$  and the specified minimum tensile strength,  $F_u$ .

Allowable loads based on existing use shall not exceed the loads calculated according to Chapters B through E, using the specified minimum yield point,  $F_{sy}$ , for  $F_y$  and the specified minimum tensile strength,  $F_u$ .

#### **A3.4 Delivered Minimum Thickness**

The uncoated minimum steel thickness of the cold-formed product as delivered to the job site shall not at any location be less than 95 percent of the thickness,  $t$ , used in its design; however, thicknesses may be less at bends, such as corners, due to cold-forming effects.

#### **A4 Loads**

##### **A4.1 Dead Load**

(Deleted per Section 2229.)

##### **A4.2 Live Load**

(Deleted per Section 2229.)

##### **A4.3 Impact Load**

For structures carrying live loads which induce impact, the assumed live load shall be increased sufficiently to provide for impact.

##### **A4.4 Wind or Earthquake Loads**

(Modified see Section 2229.)

##### **A4.5 Ponding**

Unless a roof surface is provided with sufficient slope toward points of free drainage or adequate individual drains to prevent the accumulation of rainwater, the roof system shall be investigated by rational analysis to assure stability under ponding conditions.

#### **A5 Structural Analysis and Design**

##### **A5.1 Design Basis**

This Specification is based upon the allowable stress concept presented in terms of allowable moments and loads. The allowable moments and loads are determined by dividing the corresponding nominal capacities by an accepted factor of safety.

##### **A5.2 Yield Point and Strength Increase from Cold Work of Forming**

###### **A5.2.1 Yield Point**

The yield point used in design,  $F_y$ , shall not exceed the specified minimum yield point of steels as listed in Section A3.1 or A3.2, as established in accordance with Chapter F, or as increased for cold work of forming in Section A5.2.2, or as reduced for low ductility steels in Section A3.3.2.

###### **A5.2.2 Strength Increase from Cold Work of Forming**

Strength increase from cold work of forming may be obtained by substituting  $F_{ya}$  for  $F_y$ , where  $F_{ya}$  is the average yield point of the full section. Such increase shall be limited to Sections C3.1 (excluding Section C3.1.1(b)), C4, C5, C6 and D4. The limitations and methods for determining  $F_{ya}$  are as follows:

- (a) For axially loaded compression members and flexural members whose proportions are such that the quantity  $\rho$  is unity as determined according to Section B2 for each of the component

elements of the section, the design yield stress,  $F_{ya}$ , of the steel shall be determined on the basis of one of the following methods:

- (1) full section tensile tests [see paragraph (a) of Section F3.1]
- (2) stub column tests [see paragraph (b) of Section F3.1]
- (3) computed as follows:

$$F_{ya} = CF_{yc} + (1-C)F_{yf} \quad (\text{Eq. A5.2.2-1})$$

**WHERE:**

$F_{ya}$  = Average tensile yield point of the steel in the full flange sections of flexural members

$C$  = For compression members, ratio of the total corner cross-sectional area to the total cross-sectional area of the full section; for flexural members, ratio of the total corner cross-sectional area of the controlling flange to the full cross-sectional area of the controlling flange

$F_{yf}$  = Weighted average tensile yield point of the flat portions established in accordance with Section F3.2 or virgin yield point if tests are not made

$F_{yc}$  =  $B_c F_{yv} / (R/t)^m$ , tensile yield point of corners (Eq. A5.2.2-2)

**WHEN:**

$F_{uv}/F_{yv} > 1.2$ ,  $R/t < 7$ , minimum included angle  $< 120^\circ$

$B_c = 3.69 (F_{uv}/F_{yv}) - 0.819 (F_{uv}/F_{yv})^2 - 1.79$  (Eq. A5.2.2-3)

$m = 0.192 (F_{uv}/F_{yv}) - 0.068$  (Eq. A5.2.2-4)

$R$  = Inside bend radius

$F_{yv}$  = Tensile yield point of virgin steel\*\* specified by Section A3 or established in accordance with Section F3.3

$F_{uv}$  = Ultimate tensile strength of virgin steel\*\* specified by Section A3 or established in accordance with Section F3.3

- (b) For axially loaded tension members the yield point of the steel shall be determined by either method (1) or method (3) prescribed in paragraph (a) of this Section.
- (c) The effect of any welding on mechanical properties of a member shall be determined on the basis of tests of full section specimens containing within the gage length, such welding as the manufacturer intends to use. Any necessary allowance for such effect shall be made in the structural use of the member.

**A5.3 Serviceability and Durability**

A structure shall be designed to perform its required functions during its expected life, including serviceability and durability considerations.

**A6 Reference Documents**

See Part I for modifications to this section.

This Specification recognizes other published and latest approved specifications and manuals for designs contemplated herein, as follows:

- American National Standards Institute, ANSI A58.1-1982, "Minimum Design Loads in Buildings and Other Structures," American National Standards Institute, Inc. (ANSI), 1430 Broadway, New York, New York 10018
- American Institute of Steel Construction, "Specification for the Design, Fabrication and Erection of Structural Steel for Buildings," American Institute of Steel Construction (AISC), One East Wacker Drive, Chicago, Illinois 60601, November 1, 1978
- American Welding Society, AWS D1.3-81, "Structural Welding Code—Sheet Steel," American Welding Society (AWS), 550 N.W. LeJeune Road, Miami, Florida 33126

\*\* Virgin steel refers to the condition (i.e., coiled or straight) of the steel prior to the cold-forming operation.

- Research Council on Structural Connections, Allowable Stress Design, "Specification for Structural Joints Using ASTM A325 or A490 Bolts," Research Council on Structural Connections (RCSC), American Institute of Steel Construction (AISC), One East Wacker Drive, Chicago, Illinois 60601, November 13, 1985.
- Metal Building Manufacturers Association, *Low Rise Building Systems Manual*, Metal Building Manufacturers Association (MBMA), 1230 Keith Building, Cleveland, Ohio 44115, 1986
- Steel Deck Institute, "Design Manual for Composite Decks, Formed Decks, and Roof Decks," Steel Deck Institute, Inc. (SDI), P.O. Box 9506, Canton, Ohio 44711, 1984
- Steel Joist Institute, "Standard Specifications Load Tables and Weight Tables for Steel Joists and Joist Girders," Steel Joist Institute (SJI), Suite A, 1205 48th Avenue North, Myrtle Beach, South Carolina 29577, 1986
- Rack Manufacturers Institute, "Specification for the Design, Testing and Utilization of Industrial Steel Storage Racks," Rack Manufacturers Institute (RMI), 8720 Red Oak Boulevard, Suite 201, Charlotte, North Carolina 28210, 1985
- American Iron and Steel Institute, "Stainless Steel Cold-Formed Structural Design Manual," 1974 Edition, American Iron and Steel Institute (AISI), 1133 15th Street, N.W., Washington, D.C. 20005
- American Society of Civil Engineers, "ASCE Standard, Specification for the Design and Construction of Composite Slabs," American Society of Civil Engineers (ASCE), 345 East 47th Street, New York, New York 10017, October, 1984
- American Iron and Steel Institute, "Tentative Criteria for Structural Applications of Steel Tubing and Pipe," American Iron and Steel Institute (AISI), 1133 15th Street, N.W., Washington, D.C. 20005, August, 1976

In addition to the above references this Specification recognizes the following standards from the American Society for Testing and Materials (ASTM), 1916 Race Street, Philadelphia, Pennsylvania 19013:

ASTM A36/A36M-84a, Structural Steel

ASTM A194-88, Carbon and Alloy Steel Nuts for Bolts for High-Pressure and High-Temperature Service

ASTM A242/A242M-85, High-Strength Low-Alloy Structural Steel

ASTM A307-84 (Type A), Carbon Steel Externally and Internally Threaded Standard Fasteners

ASTM A325-84, High Strength Bolts for Structural Steel Joints

ASTM A354-84 (Grade BD), Quenched and Tempered Alloy Steel Bolts, Studs, and Other Externally Threaded Fasteners (for diameter of bolt smaller than 1/2 inch)

ASTM A370-77<sup>e</sup> Mechanical Testing of Steel Products

ASTM A441M-85, High-Strength Low-Alloy Structural Manganese Vanadium Steel

ASTM A446/A446M-85 (Grades A, B, C, D, & F) Steel, Sheet, Zinc-Coated (Galvanized) by the Hot-Dip Process, Structural (Physical) Quality

ASTM A449-84a, Quenched and Tempered Steel Bolts and Studs (for diameter of bolt smaller than 1/2 inch)

ASTM A490-84, Quenched and Tempered Alloy Steel Bolts for Structural Steel Joints

ASTM A500-84, Cold-Formed Welded and Seamless Carbon Steel Structural Tubing in Rounds and Shapes

ASTM A529/A529M-85, Structural Steel with 42 ksi Minimum Yield Point (1/2 in. Maximum Thickness)

ASTM A563-88a, Carbon and Alloy Steel Nuts

ASTM A570/A570M-85 Steel, Sheet and Strip, Carbon, Hot-Rolled, Structural Quality

ASTM A572/A572M-85, High-Strength Low-Alloy Columbium-Vanadium Steels of Structural Quality

- ASTM A588/A588M-85, High-Strength Low-Alloy Structural Steel with 50 ksi Minimum Yield Point to 4 in. Thick
- ASTM A606-85 Steel, Sheet and Strip, High Strength, Low Alloy, Hot-Rolled and Cold-Rolled, with Improved Atmospheric Corrosion Resistance
- ASTM A607-85 Steel Sheet and Strip, High Strength, Low Alloy, Columbium or Vanadium, or both, Hot-Rolled and Cold-Rolled
- ASTM A611-85 (Grades A, B, C, & D) Steel, Sheet, Carbon, Cold-Rolled, Structural Quality
- ASTM A715-85 (Grades 50 & 60) Sheet Steel and Strip, High-Strength, Low-Alloy, Hot-Rolled, With Improved Formability
- ASTM A792-85a (Grades 33, 37, 40 & 50) Steel Sheet, Aluminum-Zinc Alloy-Coated by the Hot-Dip Process, General Requirements
- ASTM F436-86, Hardened Steel Washers
- ASTM F844-83(1988), Washers, Steel, Plain (Flat), Unhardened for General Use
- ASTM F959-85, Compressible Washer-Type Direct Tension Indicators for Use with Structural Fasteners

**B. ELEMENTS****B1 Dimensional Limits and Considerations****B1.1 Flange Flat-Width-to-Thickness Considerations**(a) *Maximum Flat-Width-to-Thickness Ratios*

Maximum allowable overall flat-width-to-thickness ratios,  $w/t$ , disregarding intermediate stiffeners and taking as  $t$  the actual thickness of the element, shall be as follows:

- |   |     |
|---|-----|
| (1) Stiffened compression element having <i>one</i> longitudinal edge connected to a web or flange element, the other stiffened by:     |     |
| Simple lip  | 60  |
| Any other kind of stiffener having $I_s > I_a$ and $D/w < 0.8$ according to Section B4.2  | 90  |
| (2) Stiffened compression element with <i>both</i> longitudinal edges connected to other stiffened elements                             | 500 |
| (3) Unstiffened compression element and elements with an edge stiffener having $I_s < I_a$ and $D/w \leq 0.8$ according to Section B4.2 | 60  |

**Note:** Unstiffened compression elements that have  $w/t$  ratios exceeding approximately 30 and stiffened compression elements that have  $w/t$  ratios exceeding approximately 250 are likely to develop noticeable deformation at the full allowable load, without affecting the ability of the member to carry design loads.

Stiffened elements having  $w/t$  ratios larger than 500 may be used with safety to support loads, but substantial deformation of such elements under load may occur and may render inapplicable the design formulas of this Specification.

(b) *Flange Curling*

Where the flange of a flexural member is unusually wide and it is desired to limit the maximum amount of curling or movement of the flange toward the neutral axis, the following formula applies to compression and tension flanges, either stiffened or unstiffened:

$$w_f = \sqrt{0.061tdE/f_{av}} - \sqrt[4]{(100c_t/d)} \quad (\text{Eq. B1.1-1})$$

For SI:  $\times 25.4$  for mm

**WHERE:**

$w_f$  = Width of flange projecting beyond the web; or half of the distance between webs for box- or U-type beams

$t$  = Flange thickness

$d$  = Depth of beam

$c_f$  = Amount of curling

$f_{av}$  = Average stress in the full, unreduced flange width. (Where members are designed by the effective design width procedure, the average stress equals the maximum stress multiplied by the ratio of the effective design width to the actual width.)

(c) *Shear Lag Effects—Unusually Short Spans Supporting Concentrated Loads*

Where the span of the beam is less than  $30w_f$  ( $w_f$  as defined below) and it carries one concentrated load, or several loads spaced farther apart than  $2w_f$ , the effective design width of any flange, whether in tension or compression, shall be limited to the following:

**TABLE B1.1**  
**SHORT, WIDE FLANGES MAXIMUM ALLOWABLE RATIO OF**  
**EFFECTIVE DESIGN WIDTH TO ACTUAL WIDTH**

$L/w_f$	Ratio	$L/w_f$	Ratio
30	1.00	14	0.82
25	0.96	12	0.78
20	0.91	10	0.73
18	0.89	8	0.67
16	0.86	6	0.55

**WHERE:**

$L$  = Full span for simple beams; or the distance between inflection points for continuous beams; or twice the length of cantilever beams.

$w_f$  = Width of flange projection beyond the web for I-beam and similar sections or half the distance between webs of box or U-type sections.

For flanges of I-beams and similar sections stiffened by lips at the outer edges,  $w_f$  shall be taken as the sum of the flange projection beyond the web plus the depth of the lip.

**B1.2 Maximum Web Depth-to-Thickness Ratio**

The ratio,  $h/t$ , of the webs of flexural members shall not exceed the following limitations:

(a) For unreinforced webs:  $(h/t)_{max} = 200$

(b) For webs which are provided with transverse stiffeners satisfying the requirements of Section B6.1:

(1) When using bearing stiffeners only,  $(h/t)_{max} = 260$

(2) When using bearing stiffeners and intermediate stiffeners,  
 $(h/t)_{max} = 300$

In the above,

$h$  = Depth of flat portion of web measured along the plane of web

$t$  = Web thickness

Where a web consists of two or more sheets, the  $h/t$  ratio shall be computed for the individual sheets.

**B2 Effective Widths of Stiffened Elements**

**B2.1 Uniformly Compressed Stiffened Elements**

(a) *Load Capacity Determination*

The effective widths,  $b$ , of uniformly compressed elements shall be determined from the following formulas:

$$b = w \text{ when } \lambda \leq 0.673 \quad (\text{Eq. B2.1-1})$$

$$b = \rho w \text{ when } \lambda > 0.673 \quad (\text{Eq. B2.1-2})$$

**WHERE:**

w = Flat width as shown in Figure B2.1

$$\rho = (1 - 0.22/\lambda)/\lambda \quad (\text{Eq. B2.1-3})$$

$\lambda$  is a slenderness factor determined as follows:

$$\lambda = \frac{1.052}{\sqrt{k}} \left( \frac{w}{t} \right) \sqrt{\frac{f}{E}} \quad (\text{Eq. B2.1-4})$$

**WHERE:**

f for load capacity determination is as follows:

For flexural members:

- (1) If Procedure I of Section C3.1.1 is used,  $f = F_y$  if the initial yielding is in compression in the element considered.  
If the initial yielding is in tension, the compressive stress,  $f$ , in the element considered shall be determined on the basis of the effective section at  $M_y$  (moment causing initial yield).
- (2) If Procedure II of Section C3.1.1 is used then  $f$  is the stress in the element considered at  $M_n$  determined on the basis of the effective section.
- (3) If Section C3.1.2. is used, then  $f = \frac{M_c}{S_r}$  as described in that Section in determining  $S_c$ .

For compression members  $f$  is taken equal to  $F_n$  as determined in Section C4 or D4 as applicable.

E = Modulus of elasticity

k = Plate buckling coefficient

= 4 for stiffened elements supported by a web on each longitudinal edge. Values for different types of elements are given in the applicable sections.

(b) *Deflection Determination*

The effective widths,  $b_d$ , used in computing deflections shall be determined from the following formulas:

$$b_d = w \text{ when } \lambda \leq 0.673 \quad (\text{Eq. B2.1-5})$$

$$b_d = \rho w \text{ when } \lambda > 0.673 \quad (\text{Eq. B2.1-6})$$

**WHERE:**

w = Flat width

$\rho$  = Reduction factor determined by either of the following two procedures:

- (1) Procedure I.  
A low estimate of the effective width may be obtained from Eqs. B2.1-3 and B2.1-4 where  $f_d$  is substituted for  $f$  where  $f_d$  is the computed compressive stress in the element being considered.
- (2) Procedure II.  
For stiffened elements supported by a web on each longitudinal edge an improved estimate of the effective width can be obtained by calculating  $\rho$  as follows:

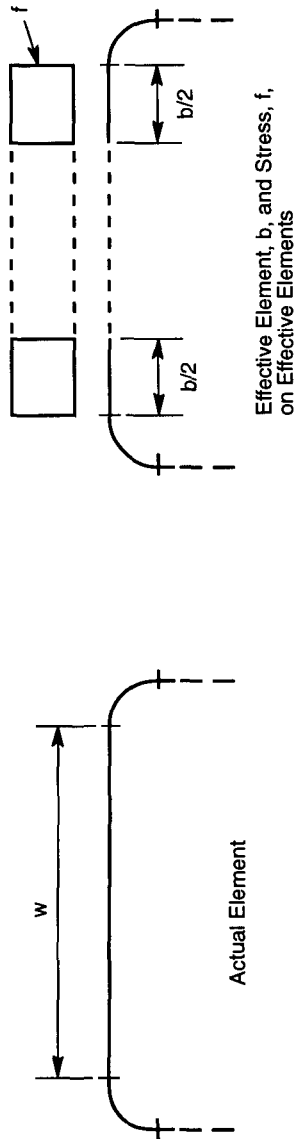

Figure B2.1-1 Stiffened Elements

$$\rho = 1 \text{ when } \lambda \leq 0.673 \quad (\text{Eq. B2.1-7})$$

$$\rho = (1.358 - 0.461/\lambda) / \lambda \text{ when } 0.673 < \lambda < \lambda_c \quad (\text{Eq. B2.1-8})$$

$$\rho = (0.41 + 0.59 \sqrt{F_y/f_d} - 0.22/\lambda) / \lambda \text{ when } \lambda \geq \lambda_c \quad (\text{Eq. B2.1-9})$$

$\rho$  shall not exceed 1.0 for all cases.

**WHERE:**

$$\lambda_c = 0.256 + 0.328 (w/t) \sqrt{F_y/E} \quad (\text{Eq. B2.1-10})$$

and  $\lambda$  is as defined by Eq. B2.1-4 except that  $f_d$  is substituted for  $f$ .

**B2.2 Uniformly Compressed Stiffened Elements with Circular Holes**(a) *Load Capacity Determination*

The effective width,  $b$ , of stiffened elements with uniform compression having circular holes shall be determined as follows:

for  $0.50 \geq \frac{d_h}{w} \geq 0$ , and  $\frac{w}{t} \leq 70$   
center-to-center spacing of holes  $> 0.50w$ , and  $3d_h$ ,

$$b = w - d_h \text{ when } \lambda \leq 0.673 \quad (\text{Eq. B2.2-1})$$

$$b = \frac{w \left[ 1 - \frac{(0.22)}{\lambda} - \frac{(0.8d_h)}{w} \right]}{\lambda} \text{ when } \lambda > 0.673 \quad (\text{Eq. B2.2-2})$$

$b$  shall not exceed  $w - d_h$

**WHERE:**

$w$  = Flat width

$d_h$  = Diameter of holes

$\lambda$  is as defined in Section B2.1.

(b) *Deflection Determination*

The effective width,  $b_d$ , used in deflection calculations shall be equal to  $b$  determined in accordance with Procedure I of Section B2.2a except that  $f_d$  is substituted for  $f$ , where  $f_d$  is the computed compressive stress in the element being considered.

**B2.3 Effective Width of Webs and Stiffened Elements with Stress Gradient**(a) *Load Capacity Determination*

The effective widths,  $b_1$  and  $b_2$ , as shown in Figure B2.3-1 shall be determined from the following formulas:

$$b_1 = b_e / (3 - \psi) \quad (\text{Eq. B2.3-1})$$

For  $\psi \leq -0.236$

$$b_2 = b_e / 2 \quad (\text{Eq. B2.3-2})$$

$b_1 + b_2$  shall not exceed the compression portion of the web calculated on the basis of effective section

For  $\psi > -0.236$

$$b_2 = b_e - b_1 \quad (\text{Eq. B2.3-3})$$

**WHERE:**

$b_e$  = Effective width  $b$  determined in accordance with Section B2.1 with  $f_1$  substituted for  $f$  and with  $k$  determined as follows:

$$k = 4 + 2(1 - \psi)^3 + 2(1 - \psi) \quad (\text{Eq. B2.3-4})$$

$$\psi = f_2/f_1$$

$f_1, f_2$  = Stresses shown in Figure B2.3-1 calculated on the basis of effective section.  $f_1$  is compression (+) and  $f_2$  can be either tension (-) or compression. In case  $f_1$  and  $f_2$  are both compression,  $f_1 \geq f_2$

(b) *Deflection Determination*

The effective widths in computing deflections at a given load shall be determined in accordance with Section B2.3a except that  $f_{d1}$  and  $f_{d2}$  are substituted for  $f_1$  and  $f_2$ , where  $f_{d1}, f_{d2}$  = Computed stresses  $f_1$  and  $f_2$  as shown in Figure B2.3-1. Calculations are based on the effective section at the load for which deflections are determined.

**B3 Effective Widths of Unstiffened Elements**

**B3.1 Uniformly Compressed Unstiffened Elements**

(a) *Load Capacity Determination*

Effective widths,  $b$ , of unstiffened compression elements with uniform compression shall be determined in accordance with Section B2.1a with the exception that  $k$  shall be taken as 0.43 and  $w$  as defined in Figure B3.1-1.

(b) *Deflection Determination*

The effective widths used in computing deflections shall be determined in accordance with Procedure I of Section B 2.1b except that  $f_d$  is substituted for  $f$  and  $k = 0.43$ .

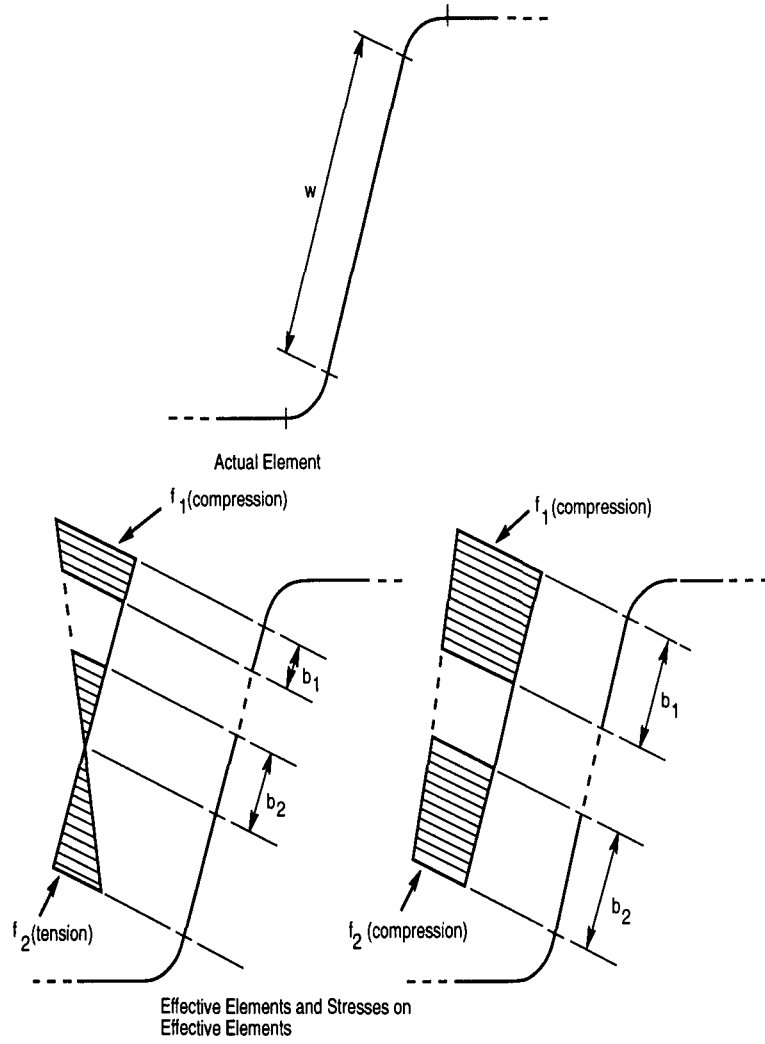

Figure B2.3-1 Stiffened Elements with Stress Gradient and Webs

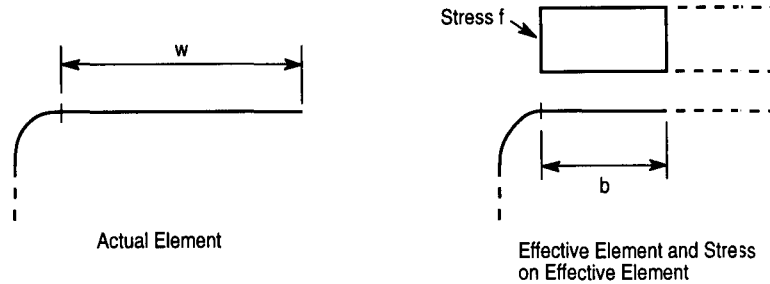

Figure B3.1-1 Unstiffened Element with Uniform Compression

### B3.2 Unstiffened Elements and Edge Stiffeners with Stress Gradient

(a) *Load Capacity Determination*

Effective widths,  $b$ , of unstiffened compression elements and edge stiffeners with stress gradient shall be determined in accordance with Section B2.1a with  $f = f_3$  as in Figure B4-2 in the element and  $k = 0.43$ .

(b) *Deflection Determination*

Effective widths,  $b$ , of unstiffened compression elements and edge stiffeners with stress gradient shall be determined in accordance with Procedure I Section B2.1b except that  $f_{d3}$  is substituted for  $f$  and  $k = 0.43$ .

### B4 Effective Widths of Elements with an Edge Stiffener or One Intermediate Stiffener

The following notation is used in this section.

$$S = 1.28 \sqrt{E/f}$$

$k$  = Buckling coefficient

$b_o$  = Dimension defined in Figure B4-1

$d, w, D$  = Dimensions defined in Figure B4-2

$d_s$  = Reduced effective width of the stiffener as specified in this section.  $d_s$ , calculated according to Section B4.2, is to be used in computing the overall effective section properties (see Figure B4-2)

$d'_s$  = Effective width of the stiffener calculated according to Section B3.1 (see Figure B4-2)

$C_1, C_2$  = Coefficients defined in Figure B4-2

$A_s$  = Reduced area of the stiffener as specified in this section.  $A_s$  is to be used in computing the overall effective section properties. The centroid of the stiffener is to be considered located at the centroid of the full area of the stiffener, and the moment of inertia of the stiffener about its own centroidal axis shall be that of the full section of the stiffener.

$I_a$  = Adequate moment of inertia of stiffener, so that each component element will behave as a stiffened element.

$I_s, A'_s$  = Moment of inertia of the full stiffener about its own centroidal axis parallel to the element to be stiffened and the effective area of the stiffener, respectively. For edge stiff-

eners the round corner between the stiffener and the element to be stiffened shall not be considered as a part of the stiffener.

For the stiffener shown in Figure B4-2:

$$I_s = (d^3 t \sin^2 \theta) / 12 \quad (\text{Eq. B4-2})$$

$$A'_s = d'_s t \quad (\text{Eq. B4-3})$$

#### B4.1 Uniformly Compressed Elements with an Intermediate Stiffener

##### (a) Load Capacity Determination

Case I:  $b_o/t \leq S$  (Eq. B4.1-1)

$$I_a = 0 \text{ (no intermediate stiffener needed)} \quad (\text{Eq. B4.1-2})$$

$$b = w \quad (\text{Eq. B4.1-3})$$

$$A_s = A'_s \quad (\text{Eq. B4.1-4})$$

Case II:  $S < b_o/t < 3S$  (Eq. B4.1-5)

$$I_a/t^4 = [50(b_o/t)/S] - 50 \quad (\text{Eq. B4.1-6})$$

$b$  and  $A_s$  shall be calculated according to Section B2.1a where

$$k = 3(I_s/I_a)^{1/2} + 1 \leq 4 \quad (\text{Eq. B4.1-7})$$

$$A_s = A'_s (I_s/I_a) \leq A'_s \quad (\text{Eq. B4.1-8})$$

Case III:  $b_o/t \geq 3S$

$$I_a/t^4 = [128(b_o/t)/S] - 285 \quad (\text{Eq. B4.1-9})$$

$b$  and  $A_s$  are calculated according to Section B2.1a where

$$k = 3(I_s/I_a)^{1/3} + 1 \leq 4 \quad (\text{Eq. B4.1-10})$$

$$A_s = A'_s (I_s/I_a) \leq A'_s \quad (\text{Eq. B4.1-11})$$

##### (b) Deflection Determination

Effective widths shall be determined as in Section B4.1a except that  $f_d$  is substituted for  $f$ .

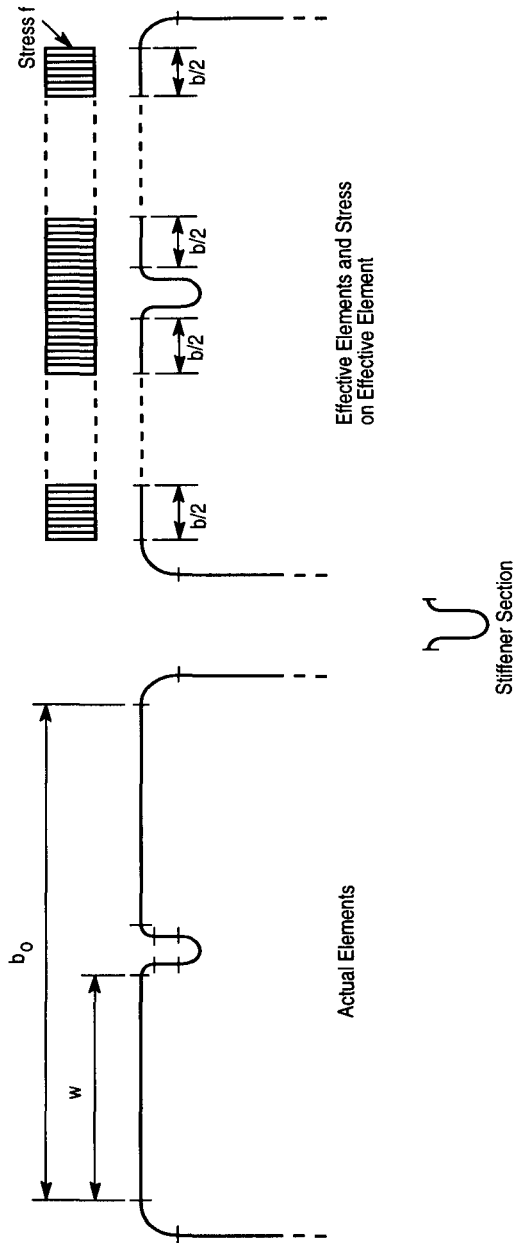

Figure B4-1 Elements with Intermediate Stiffener

**B4.2 Uniformly Compressed Elements with an Edge Stiffener***(a) Load Capacity Determination*Case I:  $w/t \leq S/3$ 

(Eq. B4.2-1)

$$I_a = 0 \text{ (no edge stiffener needed)}$$

(Eq. B4.2-2)

$$b = w$$

(Eq. B4.2-3)

$$d_s = d'_s \text{ for simple lip stiffener}$$

(Eq. B4.2-4)

$$A_s = A'_s \text{ for other stiffener shapes}$$

(Eq. B4.2-5)

Case II:  $S/3 < w/t < S$ 

$$I_a/t^4 = 399 \{ [(w/t)/S] - 0.33 \}^3$$

(Eq. B4.2-6)

$$n = 1/2$$

$$C_2 = I_s/I_a \leq 1$$

(Eq. B4.2-7)

$$C_1 = 2 - C_2$$

(Eq. B4.2-8)

b shall be calculated according to Section B2.1 where

$$k = [4.82 - 5(D/w)](I_s/I_a)^n + 0.43 \leq 5.25 - 5(D/w)$$

(Eq. B4.2-9)

for  $0.8 \geq D/w > 0.25$ 

$$k = 3.57(I_s/I_a)^n + 0.43 \leq 4.0$$

(Eq. B4.2-10)

for  $(D/w) \leq 0.25$ 

$$d_s = d'_s (I_s/I_a) \leq d'_s$$

(Eq. B4.2-11)

for simple lip stiffener

$$A_s = A'_s (I_s/I_a) \leq A'_s$$

(Eq. B4.2-12)

for other stiffener shape

Case III:  $w/t \geq S$ 

$$I_a/t^4 = [115 (w/t)/S] + 5$$

(Eq. B4.2-13)

 $C_1, C_2, b, k, d_s, A_s$  are calculated per Case II with  $n = 1/3$ .*(b) Deflection Determination*Effective widths shall be determined as in Section B4.2a except that  $f_d$  is substituted for  $f$ .

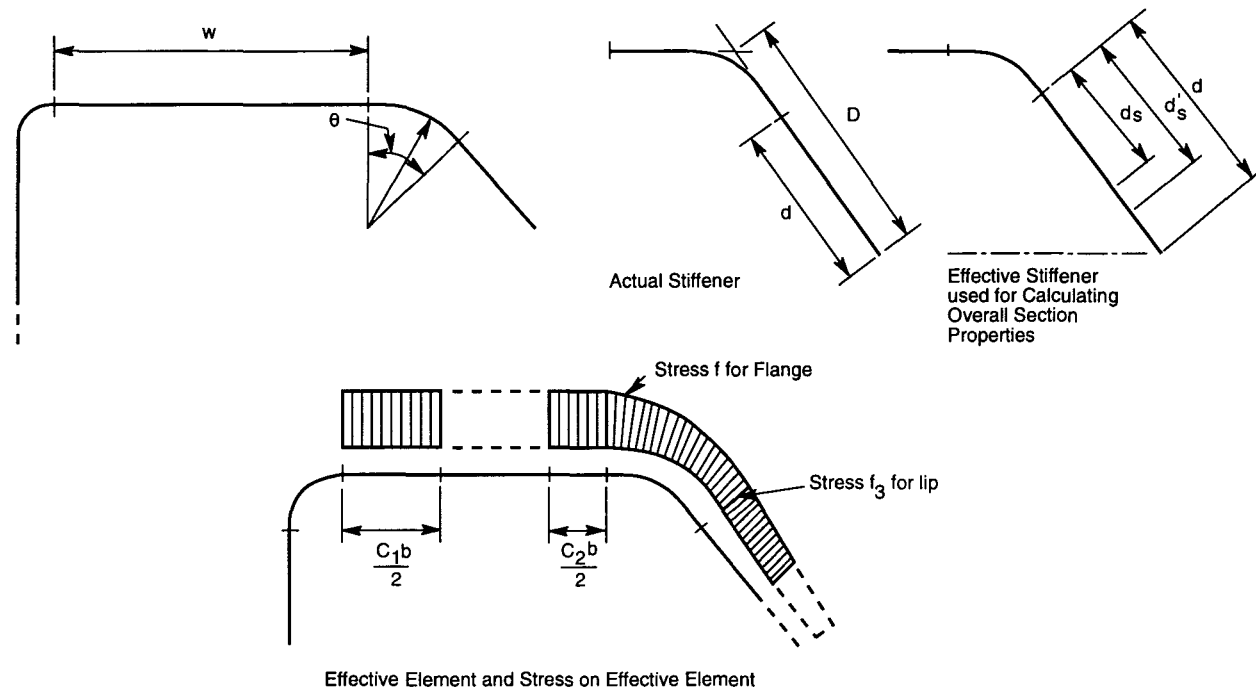

Figure B4-2 Elements with Edge Stiffener

**B5 Effective Widths of Edge Stiffened Elements with Intermediate Stiffeners or Stiffened Elements with More Than One Intermediate Stiffener**

For the determination of the effective width, the intermediate stiffener of an edge stiffened element or the stiffeners of a stiffened element with more than one stiffener shall be disregarded unless each intermediate stiffener has the minimum  $I_s$  as follows:

$$I_{\min} = [3.66 \sqrt{(w/t)^2 - (0.136E)/F_y}]t^4 \quad (\text{Eq. B5-1})$$

but not less than  $18.4 t^4$

**WHERE:**

$w/t$  = Width-thickness ratio of the larger stiffened sub-element

$I_s$  = Moment of inertia of the full stiffener about its own centroid axis parallel to the element to be stiffened

- (a) If the spacing of intermediate stiffeners between two webs is such that for the sub-element between stiffeners  $b < w$  as determined in Section B2.1, only two intermediate stiffeners (those nearest each web) shall be considered effective.
- (b) If the spacing of intermediate stiffeners between a web and an edge stiffener is such that for the sub-element between stiffeners  $b < w$  as determined in Section B2.1, only one intermediate stiffener, that nearest the web, shall be considered effective.
- (c) If intermediate stiffeners are spaced so closely that for the elements between stiffeners  $b = w$  as determined in Section B2.1, all the stiffeners may be considered effective. In computing the flat-width to thickness ratio of the entire multiple-stiffened element, such element shall be considered as replaced by an "equivalent element" without intermediate stiffeners whose width,  $b_o$ , is the full width between webs or from web to edge stiffener, and whose equivalent thickness,  $t_s$ , is determined as follows:

$$t_s = \sqrt[3]{12I_{st}/b_o} \quad (\text{Eq. B5-2})$$

**WHERE:**

$I_{st}$  = Moment of inertia of the full area of the multiple-stiffened element, including the intermediate stiffeners, about its own centroidal axis. The moment of inertia of the entire section shall be calculated assuming the "equivalent element" to be located at the centroidal axis of the multiple stiffened element, including the intermediate stiffener. The actual extreme fiber distance shall be used in computing the section modulus.

- (d) If  $w/t > 60$ , the effective width,  $b_e$ , of the sub-element or element shall be determined from the following formula:

$$\frac{b_e}{t} = \frac{b}{t} - 0.10 \left[ \frac{w}{t} - 60 \right] \quad (\text{Eq. B5-3})$$

**WHERE:**

$w/t$  = flat-width ratio of sub-element or element

$b$  = effective design width determined in accordance with the provisions of Section B2.1, in.

$b_e$  = effective design width of sub-element or element to be used in design computations, in.

For computing the effective structural properties of a member having compression sub-elements or element subject to the above reduction in effective width, the area of stiffeners (edge stiffener or intermediate stiffeners) shall be considered reduced to an effective area as follows:

For  $60 < w/t < 90$ :

$$A_{ef} = \alpha A_{st} \quad (\text{Eq. B5-4})$$

**WHERE:**

$$\alpha = (3 - 2b_e/w) - \frac{1}{30} \left[ 1 - \frac{b_e}{w} \right] \left[ \frac{w}{t} \right] \quad (\text{Eq. B5-4})$$

For  $w/t \geq 90$ :

$$A_{ef} = (b_e/w) A_{st} \quad (\text{Eq. B5-6})$$

In the above expressions,  $A_{ef}$  and  $A_{st}$  refer only to the area of the stiffener section, exclusive of any portion of adjacent elements.

The centroid of the stiffener is to be considered located at the centroid of the full area of the stiffener, and the moment of inertia of the stiffener about its own centroidal axis shall be that of the full section of the stiffener.

**B6 Stiffeners**

**B6.1 Transverse Stiffeners**

Transverse stiffeners attached to beam webs at points of concentrated loads or reactions, shall be designed as compression members. Concentrated loads or reactions shall be applied directly into the stiffeners, or each stiffener shall be fitted accurately to the flat portion of the flange to provide direct load bearing into the end of the stiffener. Means for shear transfer between the stiffener and the web shall be provided according to Chapter E. The concentrated loads or reactions shall not exceed the smaller of the allowable loads,  $P_a$ , given by (a) and (b) as follows:

$$(a) P_a = P_n / \Omega_{st} \quad (\text{Eq. B6.1-1})$$

**WHERE:**

$$P_n = F_{wy} A_c \quad (\text{Eq. B6.1-2})$$

$$\Omega_{st} = 2.00$$

$$A_c = 18t^2 + A_s, \text{ for transverse stiffeners at interior support and under concentrated load} \quad (\text{Eq. B6.1-3})$$

$$A_c = 10t^2 + A_s, \text{ for transverse stiffeners at end support} \quad (\text{Eq. B6.1-4})$$

$$F_{wy} = \text{Lower value of beam web, } F_y \text{ or stiffener section, } F_{ys}$$

$$(b) P_a = P_n / \Omega_c \quad (\text{Eq. B6.1-5})$$

**WHERE:**

$$P_n = \text{Nominal axial load evaluated according to Section C4(a) with } A_e \text{ replaced by } A_b$$

$$\Omega_c = \text{Factor of safety for axial compression evaluated according to Section C4(a)}$$

$$A_b = b_1 t + A_s, \text{ for transverse stiffeners at interior support and under concentrated load} \quad (\text{Eq. B6.1-6})$$

$$A_b = b_2 t + A_s, \text{ for transverse stiffeners at end support} \quad (\text{Eq. B6.1-7})$$

$$A_s = \text{Cross sectional area of transverse stiffeners}$$

$$b_1 = 25t [0.0024(L_{st}/t) + 0.72] \leq 25t \quad (\text{Eq. B6.1-8})$$

$$b_2 = 12t [0.0044(L_{st}/t) + 0.83] \leq 12t \quad (\text{Eq. B6.1-9})$$

$$L_{st} = \text{Length of transverse stiffener}$$

$$t = \text{Base thickness of beam web}$$

The  $w/t_s$  ratio for the stiffened and unstiffened elements of cold-formed steel transverse stiffeners shall not exceed  $1.28 \sqrt{(E/F_{ys})}$  and  $0.37 \sqrt{(E/F_{ys})}$  respectively, where  $F_{ys}$  is the yield stress,  $F_y$ , and  $t_s$  the thickness of the stiffener steel.

**B6.2 Shear Stiffeners**

Where shear stiffeners are required, the spacing shall be such that the web shear force shall not exceed the allowable shear force,  $V_a$ , permitted by Section C3.2, and the ratio  $a/h$  shall not exceed  $[260/(h/t)]^2$  nor 3.0.

The actual moment of inertia,  $I_s$ , of a pair of attached shear stiffeners, or of a single shear stiffener, with reference to an axis in the plane of the web, shall have a minimum value of

$$I_{s\min} = 5ht^3[h/a - 0.7(a/h)] \geq (h/50)^4 \quad (\text{Eq. B6.2-1})$$

The gross area of shear stiffeners shall be not less than

$$A_{st} = \frac{1 - C_v}{2} \left[ \frac{a}{h} - \frac{(a/h)^2}{(a/h) + \sqrt{1 + (a/h)^2}} \right] YDht \quad (\text{Eq. B6.2-2})$$

**WHERE:**

$$C_v = \frac{45,000k_v}{F_y(h/t)^2} \text{ when } C_v \leq 0.8 \quad (\text{Eq. B6.2-3})$$

$$\text{For SI: } C_v = \frac{1.55Ek_v}{F_y(h/t)^2} \text{ when } C_v \leq 0.8$$

$$C_v = \frac{190}{h/t} \left( \sqrt{\frac{k_v}{F_y}} \right) \text{ when } C_v > 0.8 \quad (\text{Eq. B6.2-4})$$

$$\text{For SI: } C_v = \frac{1.12}{h/t} \left( \sqrt{\frac{Ek_v}{F_y}} \right) \text{ when } C_v > 0.8$$

$$k_v = 4.00 + \frac{5.34}{(a/h)^2} \text{ when } a/h \leq 1.0 \quad (\text{Eq. B6.2-5})$$

$$k_v = 5.34 + \frac{4.00}{(a/h)^2} \text{ when } a/h > 1.0 \quad (\text{Eq. B6.2-6})$$

$a$  = Distance between transverse stiffeners

$Y$  =  $\frac{\text{Yield point of web steel}}{\text{Yield point of stiffener steel}}$

$D$  = 1.0 for stiffeners furnished in pairs

$D$  = 1.8 for single-angle stiffeners

$D$  = 2.4 for single-plate stiffeners

$t$  and  $h$  are as defined in Section B1.2

**B6.3 Non-Conforming Stiffeners**

The allowable load carrying capacity of members with transverse stiffeners that do not meet the requirements of Sections B6.1 or B6.2, such as stamped or rolled-in transverse stiffeners shall be determined by tests in accordance with Chapter F of this Specification.

**C. MEMBERS****C1 Properties of Sections**

Properties of sections (cross-sectional area, moment of inertia, section modulus, radius of gyration, etc.) shall be determined in accordance with conventional methods of structural design. Prop-

erties shall be based on the full cross section of the members (or net sections where the use of net section is applicable) except where the use of a reduced cross section, or effective design width, is required.

### C2 Tension Members

For axially loaded tension members, the applied tensile force shall not exceed  $T_a$  determined as follows:

$$T_a = T_n / \Omega_t \quad (\text{Eq. C2-1})$$

**WHERE:**

- $T_n$  = Strength of member when loaded in tension  
=  $A_n F_y$  (Eq. C2-2)
- $\Omega_t$  = Factor of safety for tension  
= 1.67
- $A_n$  = Net area of the cross section
- $F_y$  = Design yield stress as determined in Section A5.2.1

### C3 Flexural Members

#### C3.1 Strength for Bending Only

In flexural members, the applied moment uncoupled from axial load, shear, and local concentrated forces or reactions shall not exceed the allowable  $M_a$  calculated as follows:

$$M_a = M_n / \Omega_f \quad (\text{Eq. C3.1-1})$$

**WHERE:**

- $M_n$  = Smaller of the nominal moment strengths calculated according to Sections C3.1.1, C3.1.2, and C3.1.3
- $\Omega_f$  = Factor of safety for bending  
= 1.67

#### C3.1.1 Nominal Section Strength

Section strength shall be calculated either on the basis of initiation of yielding in the effective section (Procedure I) or on the basis of the inelastic reserve capacity (Procedure II) as applicable.

(a) Procedure I—Based on Initiation of Yielding

Effective yield moment based on section strength,  $M_n$ , shall be determined as follows:

$$M_n = S_e F_y \quad (\text{Eq. C3.1.1-1})$$

**WHERE:**

- $F_y$  = Design yield stress as determined in Section A5.2.1
  - $S_e$  = Elastic section modulus of the effective section calculated with the extreme compression or tension fiber at  $F_y$
- (b) Procedure II—Based on Inelastic Reserve Capacity
- The inelastic flexural reserve capacity may be used when the following conditions are met:
- (1) The member is not subject to twisting or to lateral, torsional, or torsional-flexural buckling.
  - (2) The effect of cold forming is not included in determining the yield point  $F_y$ .
  - (3) The ratio of the depth of the compressed portion of the web to its thickness does not exceed  $\lambda_1$ .
  - (4) The shear force does not exceed  $0.35F_y$  times the web area,  $h \times t$ .
  - (5) The angle between any web and the vertical does not exceed 30 degrees.

The nominal moment strength,  $M_n$ , shall not exceed either  $1.25 S_e F_y$  determined according to Procedure I or that causing a maximum compression strain of  $C_y e_y$  (no limit is placed on the maximum tensile strain).

**WHERE:**

$e_y$  = Yield strain =  $F_y/E$

$E$  = Modulus of elasticity

$C_y$  = Compression strain factor determined as follows:

- (a) Stiffened compression elements without intermediate stiffeners

$C_y = 3$  for  $w/t \leq \lambda_1$

$$C_y = 3 - 2 \left( \frac{w/t - \lambda_1}{\lambda_2 - \lambda_1} \right) \text{ for } \lambda_1 < \frac{w}{t} \lambda_2$$

$C_y = 1$  for  $w/t \geq \lambda_2$

**WHERE:**

$$\lambda_1 = \frac{1.11}{\sqrt{F_y/E}} \quad (\text{Eq. C3.1.1-2})$$

$$\lambda_2 = \frac{1.28}{\sqrt{F_y/E}} \quad (\text{Eq. C3.1.1-3})$$

- (b) Unstiffened compression elements

$C_y = 1$

- (c) Multiple-stiffened compression elements and compression elements with edge stiffeners

$C_y = 1$

When applicable, effective design widths defined in Section B3.1 shall be used in calculating section properties.  $M_n$  shall be calculated considering equilibrium of stresses, assuming an ideally elastic-plastic stress-strain curve which is the same in tension as in compression, assuming small deformation and assuming that plane sections remain plane during bending. Combined bending and web crippling shall be checked by provisions of Section C3.5.

**C3.1.2 Lateral Buckling Strength**

For the laterally unbraced segments of singly-, doubly-, and point-symmetric sections\* subject to lateral buckling,  $M_n$  shall be determined as follows:

$$M_n = S_c \frac{M_c}{S_f} \quad (\text{Eq. C3.1.2-1})$$

**WHERE:**

$S_f$  = Elastic section modulus of the full unreduced section for the extreme compression fiber

$S_c$  = Elastic section modulus of the effective section calculated at a stress  $M_c/S_f$  in the extreme compression fiber

$M_c$  = Critical moment calculated according to (a) or (b) below:

\*The provisions of this Section apply to I-, Z-, C- and other singly-symmetric section flexural members (not including multiple-web deck, U- and closed box-type members, and curved or arch members). The provisions of this Section do not apply to laterally unbraced compression flanges of otherwise laterally stable sections. Refer to C3.1.3 for C- and Z-purlins in which the tension flange is attached to sheathing.

(a) For singly-, doubly-, and point-symmetric sections:

For  $M_e > 0.5M_y$

$$M_c = M_y \left( 1 - \frac{M_y}{4M_e} \right) \quad (\text{Eq. C3.1.2-2})$$

For  $M_e \leq 0.5M_y$

$$M_c = M_e \quad (\text{Eq. C3.1.2-3})$$

**WHERE:**

$M_y$  = Moment causing initial yield at the extreme compression fiber of the full section  
=  $S_f F_y$  (Eq. C3.1.2-4)

$M_e$  = Elastic critical moment computed by the following equations:

$$= C_b r_0 A \sqrt{\sigma_{cy} \sigma_t} \quad (\text{Eq. C3.1.2-5})$$

for bending about the symmetry axis. For singly-symmetric sections, x-axis is the axis of symmetry oriented such that the shear center has a negative x-coordinate. For point-symmetric sections, use  $0.5 M_e$ .

Alternatively,  $M_e$  can be calculated using the formula for doubly-symmetric I-sections or point-symmetric sections given in (b) below

$$= C_s A \sigma_{ex} [j + C_s \sqrt{j^2 + r_0^2 (\sigma_t / \sigma_{ex})}] / C_{TF} \quad (\text{Eq. C3.1.2-6})$$

for bending about the centroidal axis perpendicular to the symmetry axis for singly symmetric sections only

$C_s$  = +1 for moment causing compression on the shear center side of the centroid

$C_s$  = -1 for moment causing tension on the shear center side of the centroid

$$\sigma_{ex} = \frac{\pi^2 E}{(K_x L_x / r_x)^2} \quad (\text{Eq. C3.1.2-7})$$

$$\sigma_{ex} = \frac{\pi^2 E}{(K_y L_y / r_y)^2} \quad (\text{Eq. C3.1.2-8})$$

$$\sigma_t = \frac{1}{A r_0^2} \left[ GJ + \frac{\pi^2 E C_w}{(K_t L_t)^2} \right] \quad (\text{Eq. C3.1.2-9})$$

$A$  = Full cross-sectional area

$C_b$  = Bending coefficient which can conservatively be taken as unity, or calculated from

$$C_b = 1.75 + 1.05[(M_1/M_2)] + 0.3 [(M_1/M_2)]^2 \leq 2.3$$

**WHERE:**

$M_1$  is the smaller and  $M_2$  the larger bending moment at the ends of the unbraced length, taken about the strong axis of the member, and where  $M_1/M_2$ , the ratio of end moments, is positive when  $M_1$  and  $M_2$  have the same sign (reverse curvature bending) and negative when they are of opposite sign (single curvature bending). When the bending moment at any point within an unbraced length is larger than that at both ends of this length, and for members subject to combined axial load and bending moment (Section C5),  $C_b$  shall be taken as unity.

$$C_{TF} = 0.6 - 0.4 (M_1/M_2)$$

**WHERE:**

$M_1$  is the smaller and  $M_2$  the larger bending moment at the ends of the unbraced length, and where  $M_1/M_2$ , the ratio of end moments, is positive when  $M_1$  and  $M_2$  have the same

sign (reverse curvature bending) and negative when they are of opposite sign (single curvature bending). When the bending moment at any point within an unbraced length is larger than that at both ends of this length, and for members subject to combined axial load and bending moment (Section C5),  $C_{TF}$  shall be taken as unity.

$$r_o = \text{Polar radius of gyration of the cross section about the shear center} \\ = \sqrt{r_x^2 + r_y^2 + x_o^2} \quad (\text{Eq. C3.1.2-10})$$

$r_x, r_y$  = Radii of gyration of the cross section about the centroidal principal axes

$E$  = Modulus of elasticity

$G$  = Shear modulus

$K_x, K_y, K_t$  = Effective length factors for bending about the x- and y-axes, and for twisting

$L_x, L_y, L_t$  = Unbraced length of compression member for bending about the x- and y-axes, and for twisting

$x_o$  = Distance from the shear center to the centroid along the principal x-axis, taken as negative

$J$  = St. Venant torsion constant of the cross section

$C_w$  = Torsional warping constant of the cross section

$$j = \frac{1}{2I_y} \left[ \int_a x^3 dA + \int_a xy^2 dA \right] - x_o \quad (\text{Eq. C3.1.2-11})$$

(b) For I- or Z-sections bent about the centroidal axis perpendicular to the web (x-axis):

In lieu of (a), the following equations may be used to evaluate  $M_c$ :

For  $M_e > 2.78M_y$

$$M_c = M_y \quad (\text{Eq. C3.1.2-12})$$

For  $2.78M_y > M_e > 0.56M_y$

$$M_c = \frac{10}{9} M_y \left( 1 - \frac{10M_y}{36M_e} \right) \quad (\text{Eq. C3.1.2-13})$$

For  $M_e \leq 0.56M_y$

$$M_c = M_e \quad (\text{Eq. C3.1.2-14})$$

#### WHERE:

$M_e$  = Elastic critical moment determined either as defined in (a) above or as follows:

$$= \pi^2 E C_b \frac{dI_{yc}}{L^2} \text{ for doubly-symmetric I-sections} \quad (\text{Eq. C3.1.2-15})$$

$$= \frac{\pi^2 E C_b dI_{yc}}{2L^2} \text{ for point-symmetric Z-sections} \quad (\text{Eq. C3.1.2-16})$$

$d$  = Depth of section

$L$  = Unbraced length of the member

$I_{yc}$  = Moment of inertia of the compression portion of a section about the centroidal axis of the entire section parallel to the web, using the full unreduced section

Other terms are defined in (a).

#### C3.1.3 Beams Having One Flange Through-Fastened to Deck or Sheathing

This section does not apply to a continuous beam for the region between inflection points adjacent to a support, or to a cantilever beam.

The nominal moment strength of a Channel or Z-section loaded in a plane parallel to the web, with the tension flange attached to deck or sheathing and with the compression flange laterally unbraced shall be determined as follows:

$$M_n = R S_e F_y \quad (\text{Eq. C3.1.3-1})$$

**WHERE:**

- R = 0.40 for simple span C sections
- = 0.50 for simple span Z sections
- = 0.60 for continuous span C sections
- = 0.70 for continuous span Z sections
- $S_e$  and  $F_y$  are defined in Section C3.1.1

The reduction factor, R, shall be limited to roof and wall systems meeting the following conditions:

- Member depth less than 11.5 inches (292 mm)
- The flanges are edge stiffened compression elements
- $60 \leq \text{depth/thickness} \leq 170$
- $2.8 \leq \text{depth/flange width} \leq 4.5$
- $16 \leq \text{flat width/thickness of flange} \leq 43$
- For continuous span systems, the lap length at each interior support in each direction (distance from center of support to end of lap) shall not be less than:
  - 1.5d for zee sections
  - 3.0d for channel sections
- Member span length no greater than 33 feet (10 058 mm)
- For continuous span systems, the longest member span shall not be more than 20% greater than the shortest span
- Both flanges are prevented from moving laterally at the supports
- Roof or wall panels shall be steel sheets, minimum of 0.019 in. (0.48 mm) coated thickness, having a minimum rib depth of 1 in. (25 mm), spaced a maximum of 12 in. (305 mm) on centers and attached in a manner to effectively inhibit relative movement between the panel and purlin flange
- Insulation shall be glass fiber blanket 0 inch to 6 inches (0 mm to 152 mm) thick compressed between the member and panel in a manner consistent with the fastener being used
- Fastener type: minimum No. 12 self-drilling or self-tapping sheet metal screws or  $3/16$ -in. (4.8 mm) rivets, washers  $1/2$  in. (13 mm) diameter
- Fasteners shall not be standoff type screws
- Fasteners shall be spaced not greater than 12 in. (305 mm) on centers and placed near the center of the beam flange

If variables fall outside any of the above stated limits, the user must perform full scale tests in accordance with Section F1 of the Specification, or apply another rational analysis procedure. In any case, the user is permitted to perform tests, in accordance with Section F1, as an alternate to the procedure described in this section.

**C3.2 Strength for Shear Only**

The shear force at any section shall not exceed the allowable shear,  $V_a$ , calculated as follows:

$$(a) \text{ For } h/t \leq 1.38 \sqrt{Ek_v/F_y} \\ V_a = 0.38t^2 \sqrt{k_v F_y E} \leq 0.4F_y h t \quad (\text{Eq. C3.2-1})$$

$$(b) \text{ For } h/t > 1.38 \sqrt{Ek_v/F_y} \\ V_a = 0.53Ek_v t^3 / h \quad (\text{Eq. C3.2-2})$$

**WHERE:**

$t$  = Web thickness

$h$  = Depth of the flat portion of the web measured along the plane of the web

$k_v$  = Shear buckling coefficient determined as follows:

1. For unreinforced webs,  $k_v = 5.34$

2. For beam webs with transverse stiffeners satisfying the requirements of Section B6

when  $a/h \leq 1.0$

$$k_v = 4.00 + \frac{5.34}{(a/h)^2} \quad (\text{Eq. C3.2-3})$$

when  $a/h > 1.0$

$$k_v = 5.34 + \frac{4.00}{(a/h)^2} \quad (\text{Eq. C3.2-4})$$

**WHERE:**

$a$  = the shear panel length for unreinforced web element

= distance between transverse stiffeners for web elements.

For a web consisting of two or more sheets, each sheet shall be considered as a separate element carrying its share of the shear force.

**C3.3 Strength for Combined Bending and Shear**

For beams with unreinforced webs, the moment,  $M$ , and shear,  $V$ , shall satisfy the following interaction equation:

$$(M/M_{axo})^2 + (V/V_a)^2 \leq 1.0 \quad (\text{Eq. C3.3-1})$$

For beams with transverse web stiffeners, the moment,  $M$ , and shear,  $V$ , shall not exceed  $M_a$  and  $V_a$ , respectively. When  $M/M_{axo} > 0.5$  and  $V/V_a > 0.7$ , then  $M$  and  $V$  shall satisfy the following interaction equation:

$$0.6 (M/M_{axo}) + (V/V_a) \leq 1.3 \quad (\text{Eq. C3.3-2})$$

In the above:

$M_a$  = Allowable moment when bending alone exists

$M_{axo}$  = Allowable moment about the centroidal axes determined in accordance with Section C3.1 excluding the provisions of Section C3.1.2,

$V_a$  = Allowable shear force when shear alone exists

**C3.4 Web Crippling Strength**

These provisions are applicable to webs of flexural members subject to concentrated loads or reactions, or the components thereof, acting perpendicular to the longitudinal axis of the member, acting in the plane of the web under consideration, and causing compressive stresses in the web.

To avoid crippling of unreinforced flat webs of flexural members having a flat width ratio,  $h/t$ , equal to or less than 200, concentrated loads and reactions shall not exceed the values of  $P_a$  given in

Table C3.4-1. Webs of flexural members for which  $h/t$  is greater than 200 shall be provided with adequate means of transmitting concentrated loads and/or reactions directly into the webs.

The formulas in Table C3.4-1 apply to beams when  $R/t \leq 6$  and to deck when  $R/t \leq 7$ ,  $N/t \leq 210$  and  $N/h \leq 3.5$ .

$P_a$  represents the concentrated load or reaction for one solid web connecting top and bottom flanges. For two or more webs,  $P_a$  shall be computed for each individual web and the results added to obtain the allowable load or reaction for the multiple web.

For built-up I-sections, or similar sections, the distance between the web connector and beam flange shall be kept as small as practical.

TABLE C3.4-1  
 $P_a$

		Shapes Having Single Webs		Shapes Having Multiple Webs <sup>(1)</sup>
		Stiffened Flanges	Unstiffened Flanges	Stiffened and Unstiffened Flanges
Opposing Loads Spaced $> 1.5h$ <sup>(2)</sup>	End Reaction <sup>(3)</sup> Interior Reaction <sup>(4)</sup>	Eq. C3.4-1 Eq. C3.4-4	Eq. C3.4-2 Eq. C3.4-4	Eq. C3.4-3 Eq. C3.4-5
Opposing Loads Spaced $\leq 1.5h$ <sup>(5)</sup>	End Reaction <sup>(3)</sup> Interior Reaction <sup>(4)</sup>	Eq. C3.4-6 Eq. C3.4-8	Eq. C3.4-6 Eq. C3.4-8	Eq. C3.4-7 Eq. C3.4-9

Footnotes and Equation References to Table C3.4-1:

- (1) I-sections made of two channels connected back to back or similar sections which provide a high degree of restraint against rotation of the web (such as I-sections made by welding two angles to a channel).
- (2) At locations of one concentrated load or reaction acting either on the top or bottom flange, when the clear distance between the bearing edges of this and adjacent opposite concentrated loads or reactions is greater than  $1.5h$ .
- (3) For end reactions of beams or concentrated loads on the end of cantilevers when the distance from the edge of the bearing to the end of the beam is less than  $1.5h$ .
- (4) For reactions and concentrated loads when the distance from the edge of bearing to the end of the beam is equal to or greater than  $1.5h$ .
- (5) At locations of two opposite concentrated loads or of a concentrated load and an opposite reaction acting simultaneously on the top and bottom flanges, when the clear distance between their adjacent bearing edges is equal to or less than  $1.5h$ .

Equations for Table C3.4-1:

$$t^2 k C_3 C_4 C_\theta [179 - 0.33(h/t)] [1 + 0.01(N/t)] \quad (\text{Eq. C3.4-1})$$

$$t^2 k C_3 C_4 C_\theta [117 - 0.15(h/t)] [1 + 0.01(N/t)] \quad (\text{Eq. C3.4-2})$$

When  $N/t > 60$ , the factor  $[1 + 0.01(N/t)]$  may be increased to  $[0.71 + 0.015(N/t)]$

$$t^2 F_y C_6 (5.0 + 0.63 \sqrt{N/t}) \quad (\text{Eq. C3.4-3})$$

$$t^2 k C_1 C_2 C_\theta [291 - 0.40(h/t)] [1 + 0.007(N/t)] \quad (\text{Eq. C3.4-4})$$

When  $N/t > 60$ , the factor  $[1 + 0.007(N/t)]$  may be increased to  $[0.75 + 0.011(N/t)]$

$$t^2 F_y C_5 (0.88 + 0.12m) (7.50 + 1.63 \sqrt{N/t}) \quad (\text{Eq. C3.4-5})$$

$$t^2 k C_3 C_4 C_\theta [132 - 0.31(h/t)] [1 + 0.01(N/t)] \quad (\text{Eq. C3.4-6})$$

$$t^2 F_y C_8 (0.64 + 0.31m)(5.0 + 0.63 \sqrt{N/t}) \quad (\text{Eq. C3.4-7})$$

$$t^2 k C_1 C_2 C_\theta [417 - 1.22(h/t)] [1 + 0.0013(N/t)] \quad (\text{Eq. C3.4-8})$$

$$t^2 F_y C_7 (0.82 + 0.15m)(7.50 + 1.63 \sqrt{N/t}) \quad (\text{Eq. C3.4-9})$$

For **SI (Equations C3.4-1 through C3.4-9)**:  $\times 4,448$  for N

In the above-referenced formulas:

$P_a$  = Allowable concentrated load or reaction per web, kips (N)

$$C_1 = (1.22 - 0.22k) \quad (\text{Eq. C3.4-10})$$

$$C_2 = (1.06 - 0.06R/t) \leq 1.0 \quad (\text{Eq. C3.4-11})$$

$$C_3 = (1.33 - 0.33k) \quad (\text{Eq. C3.4-12})$$

$$C_4 = 0.50 < (1.15 - 0.15R/t) \leq 1.0 \quad (\text{Eq. C3.4-13})$$

$$C_5 = (1.49 - 0.53k) \geq 0.6 \quad (\text{Eq. C3.4-14})$$

$$C_6 = 1 + \left( \frac{h/t}{750} \right) \text{ when } h/t \leq 150 \quad (\text{Eq. C3.4-15})$$

$$= 1.20, \text{ when } h/t > 150 \quad (\text{Eq. C3.4-16})$$

$$C_7 = 1/k, \text{ when } h/t \leq 66.5 \quad (\text{Eq. C3.4-17})$$

$$= \left[ 1.10 - \frac{h/t}{665} \right] \frac{1}{k}, \text{ when } h/t > 66.5 \quad (\text{Eq. C3.4-18})$$

$$C_8 = \left[ 0.98 - \frac{h/t}{865} \right] \frac{1}{k} \quad (\text{Eq. C3.4-19})$$

$$C_\theta = 0.7 + 0.3 (\theta / 90)^2 \quad (\text{Eq. C3.4-20})$$

$F_y$  = Design yield stress of the web, see Section A5.2.1

$h$  = Depth of the flat portion of the web measured along the plane of the web

$$k = F_y / 33 \quad (\text{Eq. C3.4-21})$$

For **SI**:  $k = F_y / 227$

$$m = t / 0.075 \quad (\text{Eq. C3.4-22})$$

$t$  = Web thickness, inches (mm)

$N$  = Actual length of bearing, inches (mm). For the case of two equal and opposite concentrated loads distributed over unequal bearing lengths, the smaller value of  $N$  shall be taken

$R$  = Inside bend radius

$\theta$  = Angle between the plane of the web and the plane of the bearing surface  $\geq 45^\circ$ , but not more than  $90^\circ$

### C3.5 Combined Bending and Web Crippling Strength

Unreinforced flat webs of shapes subjected to a combination of bending and concentrated load or reaction shall be designed to meet the following requirements:

For shapes having single unreinforced webs:

$$1.2 (P/P_a) + (M/M_{axo}) < 1.5 \quad (\text{Eq. C3.5-1})$$

Exception: At the interior supports of continuous spans, the above formula is not applicable to deck or beams with two or more single webs, provided the compression edges of adjacent webs are

laterally supported in the negative moment region by continuous or intermittently connected flange elements, rigid cladding, or lateral bracing, and the spacing between adjacent webs does not exceed 10 inches.

For shapes having multiple unreinforced webs such as I-sections made of two channels connected back-to-back, or similar sections which provide a high degree of restraint against rotation of the web (such as I-sections made by welding two angles to a channel);

$$1.1 (P/P_a) + (M/M_{axo}) < 1.5 \quad (Eq. C3.5-2)$$

Exception: When  $h/t \leq 2.33/\sqrt{F_y/E}$  and  $\lambda \leq 0.673$ , the allowable concentrated load or reaction may be determined by Section C3.4.

In the above formulas:

$P$  = Concentrated load or reaction in the presence of bending moment

$P_a$  = Allowable concentrated load or reaction in the absence of bending moment determined in accordance with Section C3.4

$M$  = Applied bending moment at, or immediately adjacent to, the point of application of the concentrated load or reaction

$M_{axo}$

= Allowable moment about the centroidal axes determined in accordance with Section C3.1 excluding the provisions of Section C3.1.2

$w$  = Flat width of the beam flange which contacts the bearing plate

$t$  = Thickness of the web or flange

$\lambda$  = Slenderness factor given by Section B2.1

#### C4 Concentrically Loaded Compression Members

This section applies to members in which the resultant of all loads acting on the member is an axial load passing through the centroid of the effective section calculated at the stress,  $F_n$ , defined in this section.

(a) The axial load shall not exceed  $P_a$  calculated as follows:

$$P_a = P_n/\Omega_c \quad (Eq. C4-1)$$

**WHERE:**

$$P_n = A_e F_n \quad (Eq. C4-2)$$

$A_e$  = Effective area at the stress  $F_n$ . For sections with circular holes,  $A_e$  shall be determined according to Section B2.2a, subject to the limitations of that section. If the number of holes in the effective length region times the hole diameter divided by the effective length does not exceed 0.015,  $A_e$  can be determined ignoring the holes.

$F_n$  is determined as follows:

$$\text{For } F_e > F_y/2 \quad F_n = F_y (1 - F_y/4F_e) \quad (Eq. C4-3)$$

$$\text{For } F_e \leq F_y/2 \quad F_n = F_e \quad (Eq. C4-4)$$

$F_e$  is the least of the elastic flexural, torsional and torsional-flexural buckling stress determined according to Sections C4.1 through C4.3.

$\Omega_c$  = Factor of safety for axial compression

= 1.92, except when  $F_e$  is determined according to Section C4.1 for fully effective sections having wall thicknesses greater than or equal to 0.09 inches and  $F_e > F_y/2$ . In this case,

$$\Omega_c = \frac{5}{3} + \frac{3}{8}R - \frac{1}{8}R^3$$

**WHERE:**

$$R = \sqrt{F_y/2F_c}$$

- (b) For C- and Z-shapes, and single-angle sections with unstiffened flanges,  $P_n$  shall be taken as the smaller of  $P_n$  calculated above and  $P_n$  calculated as follows:

$$P_n = \frac{A\pi^2E}{25.7(w/t)^2} \quad (\text{Eq. C4-5})$$

**WHERE:**

A = Area of the full, unreduced cross section

w = Flat width of the unstiffened element

t = Thickness of the unstiffened element

- (c) Angle sections shall be designed for the applied axial load, P, acting simultaneously with a moment equal to PL/1000 applied about the minor principal axis causing compression in the tips of the angle legs.
- (d) The slenderness ratio, KL/r, of all compression members preferably should not exceed 200, except that during construction only, KL/r preferably should not exceed 300.

**C4.1 Sections Not Subject to Torsional or Torsional-Flexural Buckling**

For doubly-symmetric sections, closed cross sections and any other sections which can be shown not to be subject to torsional or torsional-flexural buckling, the elastic flexural buckling stress,  $F_e$ , shall be determined as follows:

$$F_e = \frac{\pi^2E}{(KL/r)^2} \quad (\text{Eq. C4.1-1})$$

**WHERE:**

E = Modulus of elasticity

K = Effective length factor\*

L = Unbraced length of member

r = Radius of gyration of the full, unreduced cross section

**C4.2 Doubly- or Singly-Symmetric Sections Subject to Torsional or Torsional-Flexural Buckling**

For sections subject to torsional or torsional-flexural buckling,  $F_e$  shall be taken as the smaller of  $F_e$  calculated according to Section C4.1 and  $F_e$  calculated as follows:

$$F_e = \frac{1}{2\beta} \left[ (\sigma_{ex} + \sigma_t) - \sqrt{(\sigma_{ex} + \sigma_t)^2 - 4\beta\sigma_{ex}\sigma_t} \right] \quad (\text{Eq. C4.2-1})$$

Alternatively, a conservative estimate of  $F_e$  can be obtained using the following equation:

$$F_e = \frac{\sigma_t\sigma_{ex}}{\sigma_t + \sigma_{ex}} \quad (\text{Eq. C4.2-2})$$

\*In frames where lateral stability is provided by diagonal bracing, shear walls, attachment to an adjacent structure having adequate lateral stability, or floor slabs or roof decks secured horizontally by walls or bracing systems parallel to the plane of the frame, and in trusses, the effective length factor, K, for compression members which do not depend upon their own bending stiffness for lateral stability of the frame or truss, shall be taken as unity, unless analysis shows that a smaller value may be used. In a frame which depends upon its own bending stiffness for lateral stability, the effective length, KL, of the compression members shall be determined by a rational method and shall not be less than the actual unbraced length.

where  $\sigma_t$  and  $\sigma_{ex}$  are as defined in C3.1.2(b)

$$\beta = 1 - (x_o/r_o)^2 \quad (\text{Eq. C4.2-3})$$

For singly-symmetric sections, the x-axis is assumed to be the axis of symmetry.

### C4.3 Nonsymmetric Sections

For shapes whose cross sections do not have any symmetry, either about an axis or about a point,  $F_e$  shall be determined by rational analysis. Alternatively, compression members composed of such shapes may be tested in accordance with Chapter F.

### C5 Combined Axial Load and Bending

The axial force and bending moments shall satisfy the following interaction equations:

$$\frac{P}{P_a} + \frac{C_{mx}M_x}{M_{ax}\alpha_x} + \frac{C_{my}M_y}{M_{ay}\alpha_y} \leq 1.0 \quad (\text{Eq. C5-1})$$

$$\frac{P}{P_{a0}} + \frac{M_x}{M_{ax}} + \frac{M_y}{M_{ay}} \leq 1.0 \quad (\text{Eq. C5-2})$$

When  $P/P_a \leq 0.15$ , the following formula may be used in lieu of the above two formulas:

$$\frac{P}{P_a} + \frac{M_x}{M_{ax}} + \frac{M_y}{M_{ay}} \leq 1.0 \quad (\text{Eq. C5-3})$$

#### WHERE:

$P$  = Applied axial load

$M_x$  and  $M_y$  = Applied moments with respect to the centroidal axes of the effective section determined for the axial load alone. For angle sections,  $M_y$  shall be taken either as the applied moment or the applied moment plus  $PL/1000$ , whichever results in a lower value of  $P_a$ .

$P_a$  = Allowable axial load determined in accordance with Section C4

$P_{a0}$  = Allowable axial load determined in accordance with Section C4, with  $F_n = F_y$

$M_{ax}$  and  $M_{ay}$  = Allowable moments about the centroidal axes determined in accordance with Section C3

$1/\alpha_x, 1/\alpha_y$  = Magnification factors

$$= 1/[1 - (\Omega_c P/P_{cr})] \quad (\text{Eq. C5-4})$$

$\Omega_c$  = Factor of safety used in determining  $P_a$

$I_b$  = Moment of inertia of the full, unreduced cross section about the axis of bending

$$P_{cr} = \frac{\pi^2 EI_b}{(K_b L_b)^2} \quad (\text{Eq. C5-5})$$

$L_b$  = Actual unbraced length in the plane of bending

$K_b$  = Effective length factor in the plane of bending

$C_{mx}, C_{my}$  = Coefficients whose value shall be taken as follows:

1. For compression members in frames subject to joint translation (sidesway)

$$C_m = 0.85$$

2. For restrained compression members in frames braced against joint translation and not subject to transverse loading between their supports in the plane of bending

$$C_m = 0.6 - 0.4 (M_1/M_2) \quad (\text{Eq. C5-6})$$

#### WHERE:

$M_1/M_2$  is the ratio of the smaller to the larger moment at the ends of that portion of the member under consideration which is unbraced in the plane of bending.  $M_1/M_2$  is positive when the member is bent in reverse curvature and negative when it is bent in single curvature.

3. For compression members in frames braced against joint translation in the plane of loading and subject to transverse loading between their supports, the value of  $C_{in}$  may be determined by rational analysis. However, in lieu of such analysis, the following values may be used:
- (a) for members whose ends are restrained,  $C_m = 0.85$ ,
  - (b) for members whose ends are unrestrained,  $C_m = 1.0$ .

### C6 Cylindrical Tubular Members

The requirements of this Section apply to cylindrical tubular members having a ratio of outside diameter to wall thickness,  $D/t$ , not greater than  $0.441 E/F_y$ .

#### C6.1 Bending

For flexural members, the actual moment uncoupled from axial load, shear, and local concentrated forces or reactions shall not exceed  $M_a$  calculated as follows:

$$M_a = M_n / \Omega_f \quad (\text{Eq. C6.1-1})$$

**WHERE:**

$$\begin{aligned} M_n &= \text{Nominal moment} \\ \Omega_f &= \text{Factor of safety for bending} \\ &= 1.67 \end{aligned}$$

For  $D/t \leq 0.070 E/F_y$

$$M_n = 1.25 F_y S_f \quad (\text{Eq. C6.1-2})$$

For  $0.070 E/F_y < D/t \leq 0.319 E/F_y$

$$M_n = \left[ 0.970 + 0.020 \frac{E/F_y}{D/t} \right] F_y S_f \quad (\text{Eq. C6.1-3})$$

For  $0.319 E/F_y < D/t \leq 0.441 E/F_y$

$$M_n = [0.328E/(D/t)] S_f \quad (\text{Eq. C6.1-4})$$

**WHERE:**

$S_f$  = Elastic section modulus of the full, unreduced cross section

#### C6.2 Compression

The requirements of this Section apply to members in which the resultant of all loads and moments acting on the member is equivalent to a single force in the direction of the member axis passing through the centroid of the section.

The axial load shall not exceed  $P_a$  calculated as follows:

$$P_a = P_n / \Omega_c \quad (\text{Eq. C6.2-1})$$

**WHERE:**

$$P_n = F_n A_e \quad (\text{Eq. C6.2-2})$$

For  $F_e$  greater than  $F_y/2$

$$\begin{aligned} F_n &= \text{Flexural buckling stress} \\ &= F_y [1 - F_y/4F_e] \end{aligned} \quad (\text{Eq. C6.2-3})$$

$F_e$  = The elastic flexural buckling stress determined according to Section C4.1

$\Omega_c$  = Factor of safety for axial compression

$$\begin{aligned} &= \frac{5}{3} + \frac{3}{8}R - \frac{1}{8}R^3 \end{aligned} \quad (\text{Eq. C6.2-4})$$

$$R = \sqrt{F_y/2F_c} \quad (\text{Eq. C6.2-5})$$

$$A_e = [1 - (1 - R^2)(1 - A_o/A)]A \quad (\text{Eq. C6.2-6})$$

$$A_o = \left[ \frac{0.037}{\frac{DF_y}{E}} + 0.667 \right] A \leq A \text{ for } \frac{D}{t} \leq 0.441 \frac{E}{F_y} \quad (\text{Eq. C6.2-7})$$

A = Area of the unreduced cross section

For  $F_c \leq F_y/2$

$F_n = F_c$

$\Omega_c =$  Factor of safety for axial compression  
= 1.92

$A_e = A$

### C6.3 Combined Bending and Compression

Combined bending and compression shall satisfy the provisions of Section C5.

## D. STRUCTURAL ASSEMBLIES

### D1 Built-Up Sections

#### D1.1 I-Sections Composed of Two Channels

The maximum permissible longitudinal spacing of welds or other connectors  $s_{max}$ , joining two channels to form an I-section shall be

(a) For compression members:

$$s_{max} = \frac{Lr_{cy}}{2r_1} \quad (\text{Eq. D1.1-1})$$

#### WHERE:

L = Unbraced length of compression member

$r_1$  = Radius of gyration of the I-section about the axis perpendicular to the direction in which buckling would occur for the given conditions of end support and intermediate bracing

$r_{cy}$  = Radius of gyration of one channel about its centroidal axis parallel to the web

(b) For flexural members:

$$s_{max} = L / 6 \quad (\text{Eq. D1.1-2})$$

In no case shall the spacing exceed the value

$$s_{max} = \frac{2gT_s}{mq} \quad (\text{Eq. D1.1-3})$$

#### WHERE:

L = Span of beam

$T_s$  = Strength of connection in tension

g = Vertical distance between the two rows of connections nearest to the top and bottom flanges

q = Intensity of load on the beam (For methods of determination, see below).

m = Distance from the shear center of one channel to the mid-plane of its web.

For simple channels without stiffening lips at the outer edges.

$$m = \frac{w_t^2}{2w_t + d/3} \quad (\text{Eq. D1.1-4})$$

For channels with stiffening lips at the outer edges,

$$m = \frac{w_f dt}{4I_x} \left[ w_f d + 2D \left( d - \frac{4D^2}{3d} \right) \right] \quad (\text{Eq. D1.1-5})$$

$w_f$  = Projection of flanges from the inside face of the web (For channels with flanges of unequal width,  $w_f$  shall be taken as the width of the wider flange)

$d$  = Depth of channel or beam

$D$  = Overall depth of lip

$I_x$  = Moment of inertia of one channel about its centroidal axis normal to the web.

The intensity of load,  $q$ , is obtained by dividing the magnitude of concentrated loads or reactions by the length of bearing. For beams designed for a uniformly distributed load,  $q$  shall be taken equal to three times the intensity of the uniformly distributed design load. If the length of bearing of a concentrated load or reaction is smaller than the weld spacing,  $s$ , the required strength of the welds or connections closest to the load or reaction is

$$T_s = Pm/2g \quad (\text{Eq. D1.1-6})$$

The required maximum spacing of connections,  $s_{max}$ , depends upon the intensity of the load directly at the connection. Therefore, if uniform spacing of connections is used over the whole length of the beam, it shall be determined at the point of maximum local load intensity. In cases where this procedure would result in uneconomically close spacing, either one of the following methods may be adopted: (a) the connection spacing may be varied along the beam according to the variation of the load intensity; or (b) reinforcing cover plates may be welded to the flanges at points where concentrated loads occur. The shear strength of the connections joining these plates to the flanges shall then be used for  $T_s$ , and  $g$  shall be taken as the depth of the beam.

### D1.2 Spacing of Connections in Compression Elements

The spacing,  $s$ , in the line of stress, of welds, rivets, or bolts connecting a cover plate, sheet, or a non-integral stiffener in compression to another element shall not exceed

- that which is required to transmit the shear between the connected parts on the basis of the design strength per connection specified elsewhere herein; nor
- $1.16t = \sqrt{E/f_c}$ , where  $t$  is the thickness of the cover plate or sheet, and  $f_c$  is the stress at design load in the cover plate or sheet; nor
- three times the flat width,  $w$ , of the narrowest unstiffened compression element tributary to the connections, but need not be less than  $1.11t\sqrt{E/f_y}$  if  $w/t < 0.50\sqrt{E/f_y}$ , or  $1.33t\sqrt{E/f_y}$  if  $w/t \geq 0.50\sqrt{E/f_y}$ , unless closer spacing is required by (a) or (b) above.

In the case of intermittent fillet welds parallel to the direction of stress, the spacing shall be taken as the clear distance between welds, plus one-half inch (13 mm). In all other cases, the spacing shall be taken as the center-to-center distance between connections.

Exception: The requirements of this Section do not apply to cover sheets which act only as sheathing material and are not considered as load-carrying elements.

### D2 Mixed Systems

The design of members in mixed systems using cold-formed steel components in conjunction with other materials shall conform to this Specification and the applicable specification of the other material.

### D3 Lateral Bracing

Braces shall be designed to restrain lateral bending or twisting of a loaded beam or column, and to avoid local crippling at the points of attachment.

### D3.1 Symmetrical Beams and Columns

Braces and bracing systems, including connections, shall be designed considering strength and stiffness requirements.

### D3.2 Channel-Section and Z-Section Beams

The following provisions for bracing to restrain twisting of channels and Z-sections used as beams loaded in the plane of the web, apply only when (a) the top flange is connected to deck or sheathing material in such a manner as to effectively restrain lateral deflection of the connected flange, or (b) neither flange is so connected. When both flanges are so connected, no further bracing is required.

#### D3.2.1 Anchorage of Bracing for Roof Systems Under Gravity Load With Top Flange Connected to Sheathing

For channels and Z-sections designed according to Section C3.1.1, and having deck or sheathing fastened directly to the top flanges in such a manner shown to effectively inhibit relative movement between the deck or sheathing and the purlin flange, provisions shall be made to restrain the flanges so that the maximum top flange lateral displacements with respect to the purlin reaction points do not exceed the span length divided by 360. If the top flanges of all purlins face in the same direction, anchorage of the restraint system must be capable of satisfying the requirements of Sections D3.2.1(a) and D3.2.1(b). If the top flanges of adjacent lines of purlins face in opposite directions, the provisions of Section D3.2.1(a) and D3.2.1(b) do not apply.

Anchored braces may be connected to only one line of purlins in each purlin bay of each roof slope if provision is made to transmit forces from other purlin lines through the roof deck and its fastening system. Anchored braces shall be as close as possible to the flange which is connected to the deck or sheathing. Anchored braces shall be provided for each purlin bay.

For bracing arrangements other than those covered in Sections D3.2.1(a) and D3.2.1(b), tests in accordance with Chapter F shall be performed so that the type and/or spacing of braces selected are such that the test strength of the braced Z-section assembly is equal to or greater than 5/3 times its flexural design strength, instead of that required by Chapter F.

#### (a) Channel Sections

For roof systems using channel sections for purlins with all compression flanges facing in the same direction, a restraint system capable of resisting 0.05W, in addition to other loading, shall be provided where W is the load supported by all purlin lines being restrained. Where more than one brace is used at a purlin line, the restraint force 0.05W shall be divided equally between all braces.

#### (b) Z-Sections

For roof systems having a diaphragm stiffness of at least 2,000 lb/in. (350 N/m), having four to twenty Z-purlin lines with all top flanges facing in the direction of the upward roof slope, and with restraint braces at the purlin supports, midspan or one-third points, each brace shall be designed to resist a force determined as follows:

##### (1) Single-Span System with Restraints at the Supports:

$$P_L = 0.5 \left[ \frac{0.220b^{1.50}}{n_p^{0.72}d^{0.90}t^{0.60}} - \sin \theta \right] W \quad (\text{Eq. D3.2.1-1})$$

##### (2) Single-Span System with Third-Point Restraints:

$$P_L = 0.5 \left[ \frac{0.474b^{1.22}}{n_p^{0.57}d^{0.89}t^{0.33}} - \sin \theta \right] W \quad (\text{Eq. D3.2.1-2})$$

##### (3) Single-Span System with Midspan Restraint:

$$P_L = \left[ \frac{0.224b^{1.32}}{n_p^{0.65}d^{0.83}t^{0.50}} - \sin \theta \right] W \quad (\text{Eq. D3.2.1-3})$$

(4) Multiple-Span System with Restraints at the Supports:

with

$C_{tr} = 0.63$  for braces at end supports of multiple-span systems

$$P_L = C_{tr} \left[ \frac{0.053b^{1.88}L^{0.13}}{n_p^{0.95}d^{1.07}t^{0.94}} - \sin \theta \right] W \quad (\text{Eq. D3.2.1-4})$$

$C_{tr} = 0.87$  for braces at the first interior supports

$C_{tr} = 0.81$  for all other braces

(5) Multiple-Span System with Third-Point Restraints:

$$P_L = C_{th} \left[ \frac{0.181b^{1.15}L^{0.25}}{n_p^{0.54}d^{1.11}t^{0.29}} - \sin \theta \right] W \quad (\text{Eq. D3.2.1-5})$$

with

$C_{th} = 0.57$  for outer braces in exterior spans

$C_{th} = 0.48$  for all other braces

(6) Multiple-Span System with Midspan Restraints:

$$P_L = C_{ms} \left[ \frac{0.116b^{1.32}L^{0.18}}{n_p^{0.70}d^{1.00}t^{0.50}} - \sin \theta \right] W \quad (\text{Eq. D3.2.1-6})$$

with

$C_{ms} = 1.05$  for braces in exterior spans

$C_{ms} = 0.90$  for all other braces

**WHERE:**

$b$  = Flange width, in. (mm)

$d$  = Depth of section, in. (mm)

$t$  = Thickness, in. (mm)

$L$  = Span length, in. (mm)

$\theta$  = Angle between the vertical and the plane of the web of the Z-section, degrees

$n_p$  = Number of parallel purlin lines

$W$  = Total load supported by the purlin lines between adjacent supports, pounds (N)

The force,  $P_L$ , is positive when restraint is required to prevent movement of the purlin flanges in the upward roof slope direction.

For systems having less than four purlin lines, the brace force can be determined by taking 1.1 times the force found from Equations D3.2.1-1 through D3.2.1-6, with  $n_p = 4$ . For systems having more than twenty purlin lines, the brace force can be determined from Equations D3.2.1-1 through D3.2.1-6, with  $n_p = 20$ .

**D3.2.2 Neither Flange Connected to Sheathing**

Each intermediate brace, at the top and bottom flange, shall be designed to resist a lateral force,  $P_L$ , determined as follows:

- (a) For uniform loads,  $P_L = 1.5K'$  times the load within a distance  $0.5a$  each side of the brace.
- (b) For concentrated loads,  $P_L = 1.0K'$  times each concentrated load within a distance  $0.3a$  each side of the brace, plus  $1.4K'[1-(x/a)]$  times each concentrated load located farther than  $0.3a$  but not farther than  $1.0a$  from the brace.

In the above formulas:

For channels and Z-sections:

$x$  = Distance from the concentrated load to the brace

$a$  = Distance between center line of braces

For channels:

$$K' = m/d \quad (\text{Eq. D3.2.2-1})$$

**WHERE:**

$m$  = Distance from the shear center to the mid-plane of the web, as specified in Section D1.1

$d$  = Depth of channel

For Z-sections:

$$K' = I_{xy}/I_x \quad (\text{Eq. D3.2.2-2})$$

**WHERE:**

$I_{xy}$  = Product of inertia of the full section about centroidal axes parallel and perpendicular to the web

$I_x$  = Moment of inertia of the full section about the centroidal axis perpendicular to the web

Braces shall be designed to avoid local crippling at the points of attachment to the member.

Braces shall be attached both to the top and bottom flanges of the sections, at the ends and at intervals not greater than one-quarter of the span length, in such a manner as to prevent tipping at the ends and lateral deflection of either flange in either direction at intermediate braces. If one-third or more of the total load on the beam is concentrated over a length of one-twelfth or less of the span of the beam, an additional brace shall be placed at or near the center of this loaded length.

Exception: When all loads and reactions on a beam are transmitted through members which frame into the section in such a manner as to effectively restrain the section against rotation and lateral displacement, no other braces will be required.

### D3.3 Laterally Unbraced Box Beams

For closed box-type sections used as beams subject to bending about the major axis, the ratio of the laterally unsupported length to the distance between the webs of the section shall not exceed  $0.086 E/F_y$ .

### D4 Wall Studs and Wall Stud Assemblies

The safe load-carrying capacity of a stud may be computed on the basis of Section C (neglecting sheathing and using steel only) or on the basis that sheathing (attached to one or both sides of the stud) furnishes adequate lateral and rotational support to the stud in the plane of the wall, provided that the stud, sheathing, and attachments comply with the following requirements:

Both ends of the stud shall be braced to restrain rotation about the longitudinal stud axis and horizontal displacement perpendicular to the stud axis; however, the ends may or may not be free to rotate about both axes perpendicular to the stud axis. The sheathing shall be connected to the top and bottom members of the wall assembly to enhance the restraint provided to the stud and stabilize the overall assembly.

When sheathing is utilized for stability of the wall studs, the sheathing shall retain adequate strength and stiffness for the expected service life of the wall and additional bracing shall be provided as required for adequate structural integrity during construction and in the completed structure.

The equations given are based on solid-web steel studs and are applicable within the following limits:

Yield point,  $F_y \leq 50$  ksi (345 MPa)

Section depth,  $d \leq 6.0$  in. (152 mm)

Thickness,  $t \leq 0.075$  in. (1.9 mm)

Overall length,  $L \leq 16$  ft. (4877 mm)

Stud spacing,  $B$ , not less than 12 in. (305 mm) nor greater than 24 in. (610 mm)

Studs with perforations shall be designed using the results of stub column tests and/or rational analysis.

#### D4.1 Wall Studs in Compression

For studs having identical sheathing attached to both flanges, and neglecting any rotational restraint provided by the sheathing\*, the applied axial load,  $P$ , shall not exceed  $P_a$  calculated as follows:

$$P_a = A_e F_n / \Omega_c \quad (\text{Eq. D4.1-1})$$

##### WHERE:

$A_e$  = Effective area determined at  $F_n$

$\Omega_c$  = Factor of safety for axial compression, i.e., in accordance with Section C4(a) when either Sections D4.1(a) or D4.1(b) govern or 1.92 when Section D4.1(c) governs.

$F_n$  = The lowest value determined by the following three conditions:

- (a) To prevent column buckling between fasteners in the plane of the wall,  $F_n$  shall be calculated according to Section C4 with  $KL$  equal to two times the distance between fasteners.
- (b) To prevent flexural and/or torsional overall column buckling,  $F_n$  shall be calculated in accordance with Section C4 with  $F_e$  taken as the smaller of the two  $\sigma_{CR}$  values specified for the following section types, where  $\sigma_{CR}$  is the theoretical elastic buckling stress under concentric loading.
  - (1) Singly-symmetric channels and C-Sections

$$\sigma_{CR} = \sigma_{ey} + \bar{Q}_a \quad (\text{Eq. D4.1-2})$$

$$\sigma_{CR} = \frac{1}{2} \beta \left[ (\sigma_{ex} + \sigma_{IQ}) - \sqrt{(\sigma_{ex} + \sigma_{IQ})^2 - (4\beta\sigma_{ex}\sigma_{IQ})} \right] \quad (\text{Eq. D4.1-3})$$

- (2) Z-Sections

$$\sigma_{CR} = \sigma_t + \bar{Q}_t \quad (\text{Eq. D4.1-4})$$

$$\sigma_{CR} = \frac{1}{2} \left\{ (\sigma_{ex} + \sigma_{ey} + \bar{Q}_a) - \sqrt{[(\sigma_{ex} + \sigma_{ey} + \bar{Q}_a)^2 - 4(\sigma_{ex}\sigma_{ey} + \sigma_{ex}\bar{Q}_a - \sigma_{exy}^2)]} \right\} \quad (\text{Eq. D4.1-5})$$

- (3) I-Sections (doubly-symmetric)

$$\sigma_{CR} = \sigma_{ey} + \bar{Q}_a \quad (\text{Eq. D4.1-6})$$

$$\sigma_{CR} = \sigma_{ex} \quad (\text{Eq. D4.1-7})$$

In the above formulas:

$$\sigma_{ex} = \frac{\pi^2 E}{(L/r_x)^2} \quad (\text{Eq. D4.1-8})$$

$$\sigma_{exy} = (\pi^2 E I_{xy}) / (AL^2) \quad (\text{Eq. D4.1-9})$$

$$\sigma_{ey} = \frac{\pi^2 E}{(L/r_y)^2} \quad (\text{Eq. D4.1-10})$$

\*Studs with sheathing on one flange only, or with unidentical sheathing on both flanges, or having rotational restraint that is not neglected, or having any combination of the above, shall be designed in accordance with the same basic analysis principles used in deriving the provisions of this Section.

$$\sigma_t = \frac{1}{Ar_o^2} \left[ GJ + \frac{\pi^2 EC_w}{(L)^2} \right] \quad (Eq. D4.1-11)$$

$$\sigma_{tQ} = \sigma_t + \bar{Q}_t \quad (Eq. D4.1-12)$$

$\bar{Q}$  =  $\bar{q}$  B = Design shear rigidity for sheathing on both sides of wall assembly

$\bar{q}$  = Design shear rigidity for sheathing per inch of stud spacing (see Table D4)

B = Stud spacing

$$\bar{Q}_a = \bar{Q} / A \quad (Eq. D4.1-13)$$

A = Area of full unreduced cross section

L = Length of stud

$$\bar{Q}_t = (\bar{Q}d^2) / (4Ar_o^2) \quad (Eq. D4.1-14)$$

d = Depth of section

$I_{xy}$  = Product of inertia

- (c) To prevent shear failure of the sheathing, a value of  $F_n$  shall be used in the following equations so that the shear strain of the sheathing,  $\gamma$ , does not exceed the permissible shear strain,  $\bar{\gamma}$ . The shear strain,  $\gamma$ , shall be determined as follows:

$$\gamma = (\pi / L) [C_1 + (E_1 d/2)] \quad (Eq. D4.1-15)$$

**WHERE:**

$C_1$  and  $E_1$  are the absolute values of  $C_1$  and  $E_1$  specified below for each section type:

- (1) Singly-Symmetric Channels and C-Sections

$$C_1 = (F_n C_o) / (\sigma_{ey} - F_n + \bar{Q}_a) \quad (Eq. D4.1-16)$$

$$E_1 = \frac{F_n[(\sigma_{ex} - F_n)(r_o^2 E_o - x_o D_o) - F_n x_o (D_o - x_o E_o)]}{(\sigma_{ex} - F_n)r_o^2(\sigma_{tQ} - F_n) - (F_n x_o)^2} \quad (Eq. D4.1-17)$$

- (2) Z-Sections

$$C_1 = \frac{F_n[C_o(\sigma_{ex} - F_n) - D_o \sigma_{exy}]}{(\sigma_{ey} - F_n + \bar{Q}_a)(\sigma_{ex} - F_n) - \sigma_{exy}^2} \quad (Eq. D4.1-18)$$

$$E_1 = (F_n E_o) / (\sigma_{tQ} - F_n) \quad (Eq. D4.1-19)$$

- (3) I-Sections

$$C_1 = (F_n C_o) / (\sigma_{ey} - F_n + \bar{Q}_a) \quad (Eq. D4.1-20)$$

$$E_1 = 0$$

**WHERE:**

$x_o$  = distance from shear center to centroid along principal x-axis, in. (absolute value)

$C_o$ ,  $E_o$ , and  $D_o$  are initial column imperfections which shall be assumed to be at least

$$C_o = L/350 \text{ in a direction parallel to the wall} \quad (Eq. D4.1-21)$$

$$D_o = L/700 \text{ in a direction perpendicular to the wall} \quad (Eq. D4.1-22)$$

$$E_o = L/(d \times 10,000), \text{ rad.}, \text{ a measure of the initial twist of the stud from the initial, ideal, unbuckled shape} \quad (Eq. D4.1-23)$$

If  $F_n > 0.5 F_y$ , then in the definitions for  $\sigma_{ey}$ ,  $\sigma_{ex}$ ,  $\sigma_{exy}$  and  $\sigma_{tQ}$ , the parameters E and G shall be replaced by E' and G', respectively, as defined below:

$$E' = 4EF_n (F_y - F_n) / F_y^2 \quad (Eq. D4.1-24)$$

$$G' = G (E'/E) \quad (Eq. D4.1-25)$$

Sheathing parameters  $\bar{q}_o$  and  $\bar{\gamma}$  may be determined from representative full-scale tests, conducted and evaluated as described by published documented methods or from the small-scale-test values given in Table D4.

#### D4.2 Wall Studs in Bending

For studs having identical sheathing attached to both flanges, and neglecting any rotational restraint provided by the sheathing,\* the allowable moments are  $M_{axo}$  and  $M_{ayo}$

where

$M_{axo}$  and  $M_{ayo}$  = Allowable moments about the centroidal axes determined in accordance with Section C3.1, excluding the provisions of Section C3.1.2 (lateral buckling)

#### D4.3 Wall Studs with Combined Axial Load and Bending

The axial load and bending moments shall satisfy the interaction equations of Section C5 with the following redefined terms:

$P_a$  = Allowable axial load determined according to Section D4.1

$M_{ax}$  and  $M_{ay}$  in Equations C5-1 and C5-3 shall be replaced by allowable moments,  $M_{axo}$  and  $M_{ayo}$ , respectively.

**TABLE D4**  
Sheathing Parameters<sup>(1)</sup>

Sheathing <sup>(2)</sup>	$\bar{q}_o$ <sup>(3)</sup> k/in.	$\bar{\gamma}$ in./in.
	× 175 for N/mm	mm/mm
<sup>3</sup> / <sub>8</sub> to <sup>5</sup> / <sub>8</sub> in. (9.5 mm to 16 mm) thick gypsum	2.0	0.008
Lignocellulosic board	1.0	0.009
Fiberboard (regular or impregnated)	0.6	0.007
Fiberboard (heavy impregnated)	1.2	0.010

(1) The values given are subject to the following limitations:

All values are for sheathing on both sides of the wall assembly.

All fasteners are No. 6, type S-12, self-drilling drywall screws with pan or bugle head, or equivalent, at 6- to 12-inch (152 mm to 305 mm) spacing.

(2) All sheathing is <sup>1</sup>/<sub>2</sub>-inch (13 mm) thick except as noted.

(3)  $\bar{q} = \bar{q}_o (2-s/12)$  (Eq. D4.1-26)

For SI: (3)  $\bar{q} = \bar{q}_o (2-s/304.8)$

where s = fastener spacing, in. (mm)

For other types of sheathing,  $\bar{q}_o$  and  $\bar{\gamma}$  may be determined conservatively from representative small-specimen tests as described by published documented methods.

#### D5 Floor, Roof or Wall Steel Diaphragm Construction

The in-plane structural performance of floor, roof or wall steel diaphragm construction shall be established by calculation or test. The allowable in-plane load carrying capacity  $S_a$  shall be:

$$S_a = S_n / \Omega_s \quad (\text{Eq. D5-1})$$

**WHERE:**

$S_n$  = the nominal diaphragm shear strength

\*Studs with sheathing on one flange only, or with unidentical sheathing on both flanges, or having rotational restraint that is not neglected, or having any combination of the above, shall be designed in accordance with the same basic analysis principles used in deriving the provisions of this Section.

$\Omega_s$  = the factor of safety for diaphragm shear as specified below:

- = 3.0 for welded connections or for combinations of welds and mechanical connections subjected to earthquake loads, or subjected to load combinations which include earthquake loads.
- = 2.5 for mechanical connections subjected to earthquake loads, or subjected to load combinations which include earthquake loads. For backed-up fasteners (bolts, rivets, spreading back fasteners or the like)  $\Omega_s$  may be taken as 2.3.
- = 2.75 for welded connections or for combinations of welds and mechanical connections subjected to wind loads or subjected to load combinations which include wind loads.
- = 2.35 for mechanical connections subjected to wind loads or subjected to load combinations which include wind loads. For backed-up fasteners (bolts, rivets, spreading back fasteners or the like)  $\Omega_s$  may be taken as 2.1.

Although Section A4.4 of the Specification allows forces to be multiplied by 0.75 when the loading consists of wind or seismic loads acting either alone or in combination with other loads, this decrease in loads is not permitted for diaphragms.

For load combinations not involving wind or seismic loads:

$\Omega_s = \frac{2.75}{0.75}$  for welded connections or for combinations of welds and mechanical connections.

$\Omega_s = \frac{2.35}{0.75}$  for mechanical connections.

## E. CONNECTIONS AND JOINTS

### E1 General Provisions

Connections shall be designed to transmit the maximum load in the connected member. Proper regard shall be given to eccentricity.

### E2 Welded Connections

Arc welds on steel where each connected part is over 0.18 inch (4.6 mm) in thickness shall be made in accordance with AISC Specification (Section A6).

Except as modified herein, arc welds on steel where at least one of the connected parts is 0.18 inch (4.6 mm) or less in thickness shall be made in accordance with the AWS D-1.3 (Section A6). Welders and welding procedures shall be qualified as specified in AWS D1.3. These provisions are intended to cover the welding positions as shown in Table E2.

Resistance welds shall be made in conformance with the procedures given in AWS C1.1-66, "Recommended Practices for Resistance Welding" or AWS C1.3-70, "Recommended Practice for Resistance Welding Coated Low Carbon Steels."

TABLE E2

Connection	Welding Position					
	Square Groove Butt Weld	Arc Spot Weld	Arc Seam Weld	Fillet Weld, Lap or T	Flare-Bevel Groove	Flare-V Groove Weld
Sheet to Sheet	F H V OH	— — — —	F H — —	F H V OH	F H V OH	F H V OH
Sheet to Supporting Member	— — — —	F — — —	F — — —	F H V OH	F H V OH	— — — —

(F = flat, H = horizontal, V = vertical, OH = overhead)

The load on each weld shall not exceed  $P_a$ , calculated as follows:

$$P_a = P_n / \Omega_w \quad (\text{Eq. E2-1})$$

**WHERE:**

$\Omega_w$  = Factor of safety for arc welded connections  
= 2.50

$P_n$  = Nominal strength of welds determined according to Sections E2.1 through E2.5.

**E2.1 Groove Welds in Butt Joints**

The maximum load for a groove weld in a butt joint, welded from one or both sides, shall be determined on the basis of the lower strength base steel in the connection, provided that an effective throat equal to or greater than the thickness of the material is consistently obtained.

**E2.2 Arc Spot Welds**

Arc spot welds permitted by this Specification are for welding sheet steel to thicker supporting members in the flat position. Arc spot welds (puddle welds) shall not be made on steel where the thinnest connected part is over 0.15 inch (3.8 mm) thick, nor through a combination of steel sheets having a total thickness over 0.15 inch (3.8 mm).

Weld washers, Figures E2.2(A) and E2.2(B), shall be used when the thickness of the sheet is less than 0.028 inch (0.71 mm). Weld washers shall have a thickness between 0.05 and 0.08 inch (1.3 mm and 2.0 mm) with a minimum prepunched hole of  $3/8$ -inch (9.5 mm) diameter.

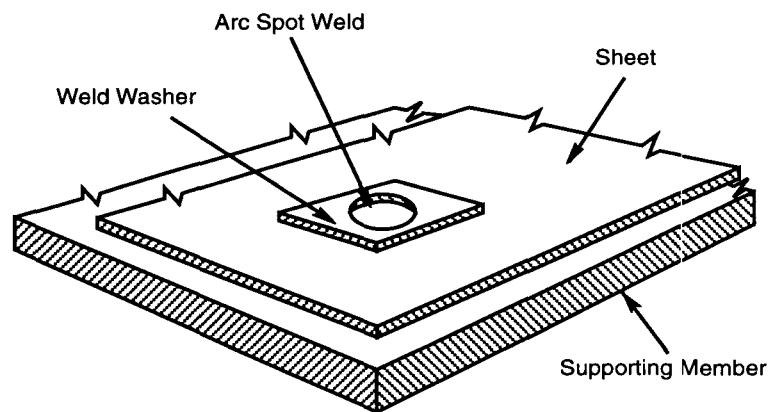

Figure E2.2A Typical Weld Washer

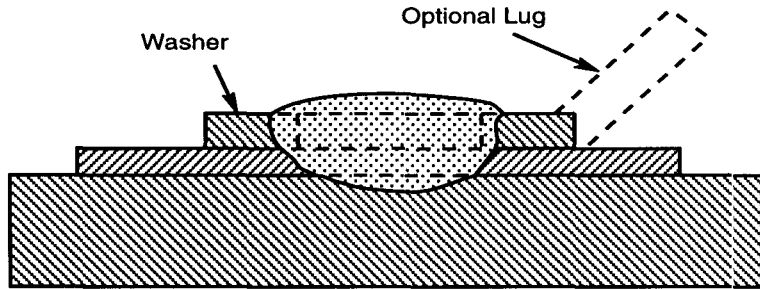

Figure E2.2B Arc Spot Weld Using Washer

Arc spot welds shall be specified by minimum effective diameter of fused area,  $d_e$ . Minimum allowable effective diameter is  $3/8$  inch (9.5 mm).

The nominal shear load,  $P_n$ , on each arc spot weld between sheet or sheets and supporting member shall not exceed the smaller of either

$$P_n = 0.625 d_e^2 F_{xx}; \text{ or} \quad (\text{Eq. E2.2-1})$$

For  $(d_a/t) \leq 0.815 \sqrt{E/F_u}$ :

$$P_n = 2.20 t d_a F_u; \quad (\text{Eq. E2.2-2})$$

For  $0.815 \sqrt{E/F_u} < (d_a/t) < 1.397 \sqrt{E/F_u}$ :

$$P_n = 0.280 \left[ 1 + \frac{5.59t \sqrt{E}}{d_a \sqrt{F_u}} \right] t d_a F_u; \quad (\text{Eq. E2.2-3})$$

For  $(d_a/t) \geq 1.397 \sqrt{E/F_u}$ :

$$P_n = 1.40 t d_a F_u \quad (\text{Eq. E2.2-4})$$

**WHERE:**

$d$  = Visible diameter of outer surface of arc spot weld

$d_a$  = Average diameter of the arc spot weld at mid-thickness of  $t$  [where  $d_a = (d-t)$  for a single sheet, and  $(d - 2t)$  for multiple sheets (not more than four lapped sheets over a supporting member)]

$d_e$  = Effective diameter of fused area

$$d_e = 0.7d - 1.5t \text{ but } \leq 0.55d \quad (\text{Eq. E2.2-5})$$

$t$  = Total combined base steel thickness (exclusive of coatings) of sheets involved in shear transfer

$F_{xx}$  = Stress level designation in AWS electrode classification

$F_{sy}$  = Yield point as specified in Section A3.1 or A3.2

$F_u$  = Tensile strength as specified in Section A3.1 or A3.2 or as reduced for low ductility steel

**Note:** See Figures E2.2(C) and E2.2(D) for diameter definitions.

The distance measured in the line of force from the centerline of a weld to the nearest edge of an adjacent weld or to the end of the connected part toward which the force is directed shall not be less than the value of  $e_{min}$  as given in the following:

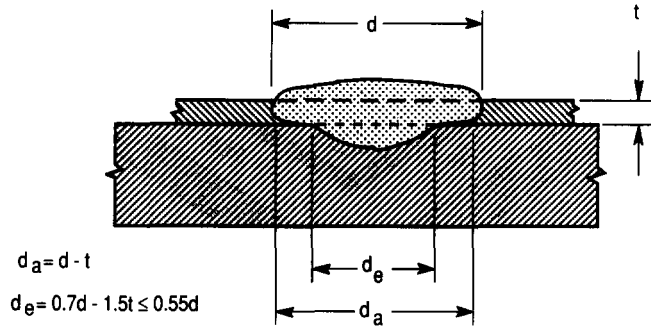

(C) Arc Spot Weld-Single Thickness of Sheet

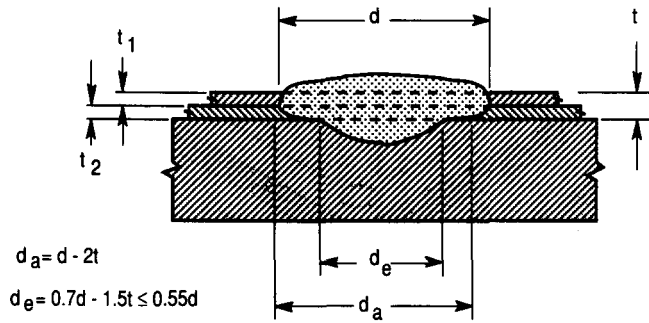

(D) Arc Spot Weld-Double Thickness of Sheet

Figure E2.2 C, D Arc Spot Welds

(Eq. E2.2-6)

$$e_{min} = e \Omega_e$$

WHERE:

$$e = \frac{P}{F_u t} \quad (Eq. E2.2-7)$$

$\Omega_e$  = Factor of safety for sheet tearing

= 2.0 when  $F_u/F_{sy} \geq 1.15$

= 2.22 when  $F_u/F_{sy} < 1.15$

P = Force transmitted by weld

t = Thickness of thinnest connected sheet

**Note:** See Figures E2.2(E) and E2.2(F) for edge distances of arc welds.

In addition, the distance from the centerline of any weld to the end or boundary of the connected member shall not be less than 1.5d. In no case shall the clear distance between welds and the end of member be less than 1.0d.

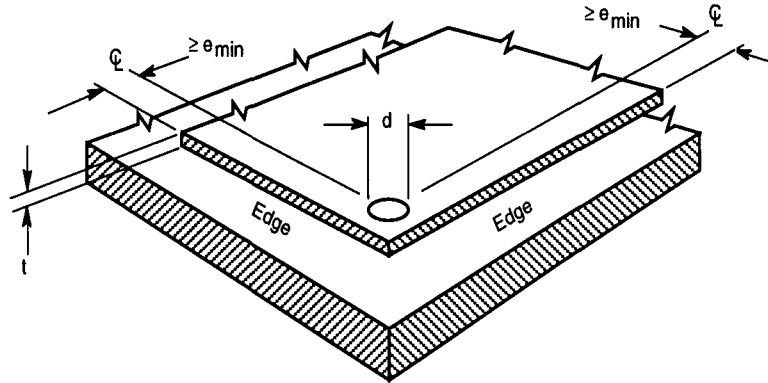

(E) Single Sheet

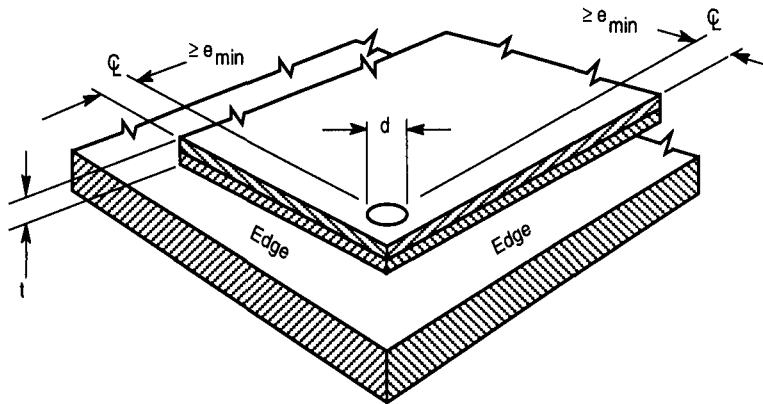

(F) Double Sheet

**Figure E2.2 E, F Edge Distances for Arc Spot Welds**

The nominal tension load,  $P_n$ , on each arc spot weld between sheet and supporting member, shall not exceed:

$$P_n = 0.7 t d_a F_u \quad (\text{Eq. E2.2-8})$$

The following additional limitations for use in Eq. 2.2-8 shall apply:

$$e_{\min} \geq d$$

$$F_{xx} \geq$$

$$60 \text{ ksi (413 MPa)}$$

$$F_u \leq 60 \text{ ksi (413 MPa)}$$

$$t \geq 0.028 \text{ in. (0.71 mm)}$$

If it can be shown by measurement that a given weld procedure will consistently give a larger effective diameter,  $d_e$ , or average diameter,  $d_a$ , as applicable, this larger diameter may be used providing the particular welding procedure used for making those welds is followed.

**E2.3 Arc Seam Welds**

Arc seam welds [Figure E2.3(A)] covered by this Specification apply only to the following joints:

- (a) Sheet to thicker supporting member in the flat position.
- (b) Sheet to sheet in the horizontal or flat position.

The shear load,  $P_n$ , on each arc seam weld shall not exceed either

$$P_n = \left[ \frac{d_e^2}{4} + \frac{LD_e}{3} \right] 2.5F_{xx}; \text{ or} \quad (\text{Eq. E2.3-1})$$

$$P_n = 2.5 tF_u(0.25L + 0.96 d_a) \quad (\text{Eq. E2.3-2})$$

**WHERE:**

$d$  = width of arc seam weld

$L$  = Length of seam weld not including the circular ends  
(For computation purposes,  $L$  shall not exceed  $3d$ .)

$d_a$  = Average width of seam weld

where

$d_a = (d-t)$  for a single sheet, and (Eq. E2.3-3)

$(d-2t)$  for a double sheet (Eq. E2.3-4)

$d_e$  = Effective width of arc seam weld at fused surfaces

$d_e = 0.7d-1.5t$  (Eq. E2.3-5)

and  $F_u$  and  $F_{xx}$  are defined in Section E2.2. The minimum edge distance shall be as determined for the arc spot weld, Section E2.2 [see Figure E2.3(B)].

If it can be shown by measurement that a given weld procedure will consistently give a larger effective width,  $d_e$  or  $d_a$  as applicable, this value may be used providing the particular welding procedure used for making the welds that are measured is followed.

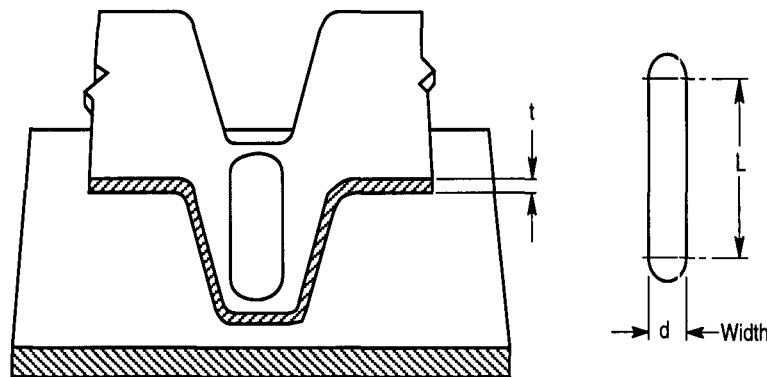

**Figure E2.3A Arc Seam Welds—  
Sheet to Supporting Member in Flat Position**

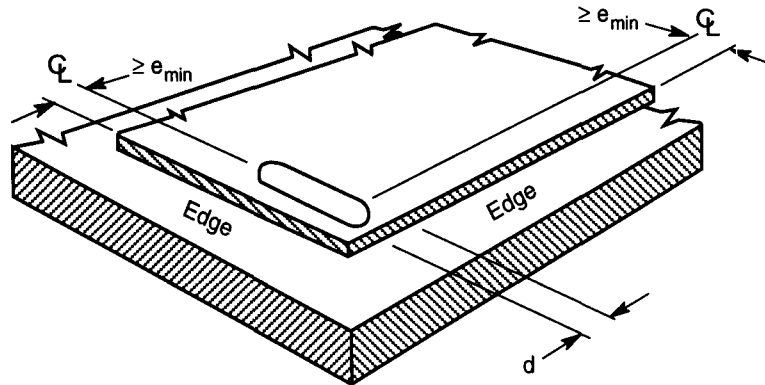

Figure E2.3B Edge Distances for Arc Seam Welds

#### E2.4 Fillet Welds

Fillet welds covered by this Specification apply to the welding of joints in any position, either

- (a) Sheet to sheet, or
- (b) Sheet to thicker steel member.

The shear load,  $P_n$ , on a fillet weld in lap and T-joints shall not exceed the following:

For longitudinal loading:

For  $L/t < 25$  :

$$P_n = \left(1 - \frac{0.01L}{t}\right) tLF_u \quad (\text{Eq. E2.4-1})$$

For  $L/t \geq 25$ :

$$P_n = 0.75 tLF_u \quad (\text{Eq. E2.4-2})$$

For transverse loading:

$$P_n = tLF_u \quad (\text{Eq. E2.4-3})$$

#### WHERE:

$t$  = Least value of  $t_1$  or  $t_2$ , Figure E2.4

In addition, for  $t > 0.150$  inch (3.81 mm), the allowable load for a fillet weld in lap and T-joints shall not exceed:

$$P_n = 0.75 t_w LF_{xx} \quad (\text{Eq. E2.4-4})$$

#### WHERE:

$L$  = Length of fillet weld

$t_w$  = Effective throat =  $0.707 w_1$  or  $0.707 w_2$ , whichever is smaller. A larger effective throat may be taken if it can be shown by measurement that a given welding procedure will consistently give a larger value providing the particular welding procedure used for making the welds that are measured is followed.

$w_1$  and  $w_2$  = leg on weld (see Figure E2.4).

$F_u$  and  $F_{xx}$  are defined in Section E2.2.

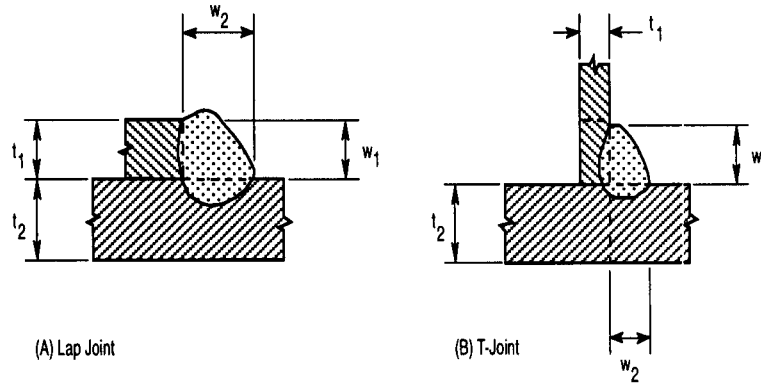

Figure E2.4 Fillet Welds

**E2.5 Flare Groove Welds**

Flare groove welds covered by this Specification apply to welding of joints in any position, either:

- (a) Sheet to sheet for flare-V groove welds, or
- (b) Sheet to sheet for flare-bevel groove welds, or
- (c) Sheet to thicker steel member for flare-bevel groove welds.

The shear load,  $P_n$ , on a weld shall be governed by the thickness,  $t$ , of the sheet steel adjacent to the weld. The load shall not exceed:

For flare-bevel groove welds, transverse loading [see Figure E2.5(A)]:

$$P_n = 0.833tLF_u \tag{Eq. E2.5-1}$$

For flare groove welds, longitudinal loading [see Figures E2.5(B), E2.5(C), and E2.5(D)]:

If the effective throat,  $t_w$ , is equal to or greater than  $t$  but less than  $2t$  or if the lip height is less than weld length,  $L$ , then:

$$P_n = 0.75tLF_u \tag{Eq. E2.5-2}$$

If  $t_w$  is equal to or greater than  $2t$  and the lip height is equal to or greater than  $L$ , then:

$$P_n = 1.50tLF_u \tag{Eq. E2.5-3}$$

In addition, if  $t > 0.15$  inch (3.81 mm), then:

$$P_n = 0.75t_wLF_{xx} \tag{Eq. E2.5-4}$$

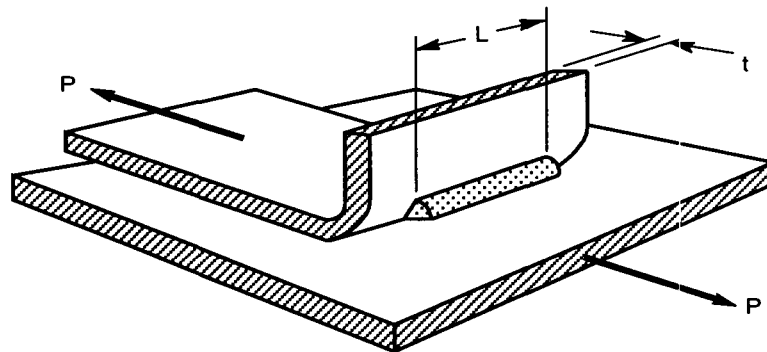

Figure E2.5A Flare-Bevel Groove Weld

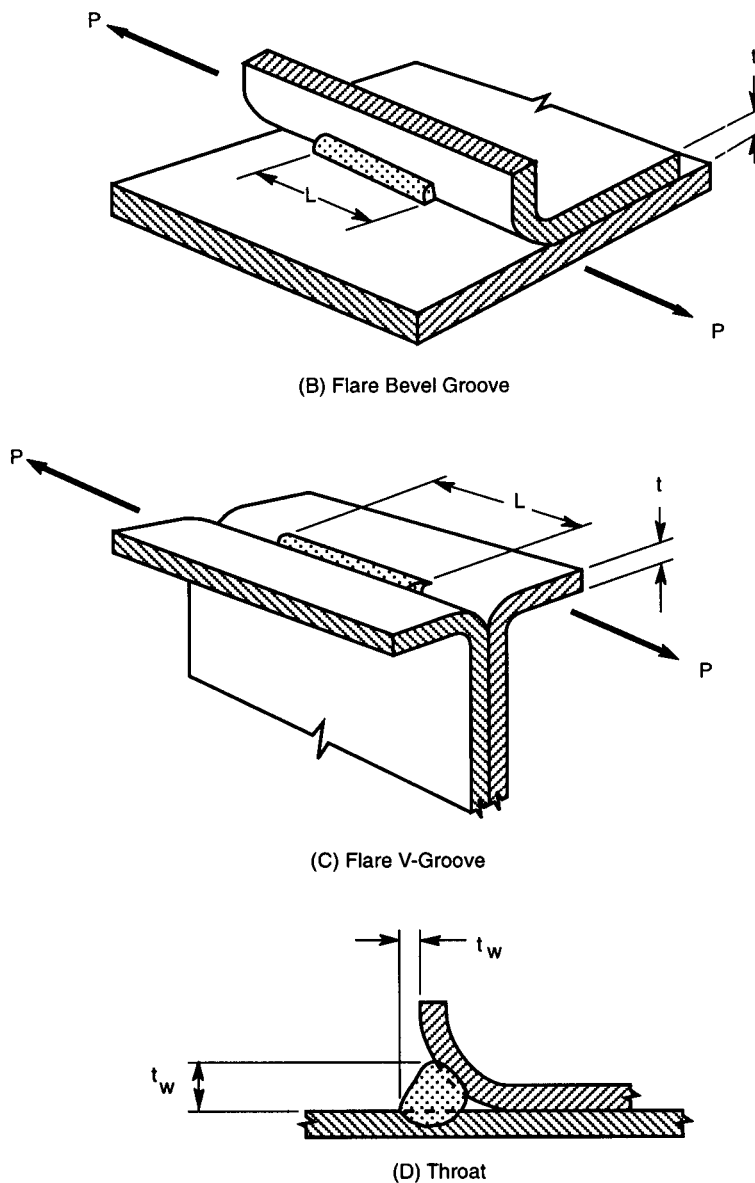

Figure E2.5 B, C, D Shear in Flare Groove Welds

**E2.6 Resistance Welds**

In sheets joined by spot welding the nominal shear strength per spot,  $P_n$ , is as follows:

**TABLE E2.6**

Thickness of Thinnest Outside Sheet, in.	Nominal Shear Strength per Spot, kips	Thickness of Thinnest Outside Sheet, in.	Nominal Shear Strength per Spot, kips
× 25.4 for mm	× 4448 for N	× 25.4 for mm	× 4448 for N
0.010	0.13	0.080	3.33
0.020	0.48	0.090	4.00
0.030	1.00	0.100	4.99
0.040	1.42	0.110	6.07
0.050	1.65	0.125	7.29
0.060	2.28	0.190	10.16
0.070	2.83	0.250	15.00

**E3 Bolted Connections**

The following requirements govern bolted connections of cold-formed steel structural members in which the thickness of the thinnest connected part is less than  $\frac{3}{16}$  inch (4.8 mm) and there are no gaps between connected parts. For bolted connections in which the thinnest connected part is equal to or greater than  $\frac{3}{16}$  inch (4.8 mm), refer to AISC Specification (Section A.6).

Bolts, nuts and washers shall generally conform to one of the following specifications:

A 914, A 307 (Type A), A 325, A 354 (Grade BD), A 449, A 490, A 563, F 436, F 844 and F 959.

When other than the above are used, drawings shall indicate clearly the type and size of fasteners to be employed and the allowable force assumed in design.

Bolts shall be installed and tightened to achieve satisfactory performance of the connections involved under usual service conditions.

The holes for bolts shall not exceed the sizes specified in Table E3, except that larger holes may be used in column base details or structural systems connected to concrete walls.

**TABLE E3**  
**Maximum Size of Bolt Holes, Inches**

Nominal Bolt Diameter, d in.	Standard Hole Diameter, d in.	Oversized Hole Diameter, d in.	Short-Slotted Hole Dimensions, in.	Long-Slotted Hole Dimensions, in.
× 25.4 for mm				
$< \frac{1}{2}$	$d + \frac{1}{32}$	$d + \frac{1}{16}$	$(d + \frac{1}{32})$ by $(d + \frac{1}{4})$	$(d + \frac{1}{32})$ by $(2\frac{1}{2} d)$
$\geq \frac{1}{2}$	$d + \frac{1}{16}$	$d + \frac{1}{8}$	$(d + \frac{1}{16})$ by $(d + \frac{1}{4})$	$(d + \frac{1}{16})$ by $(2\frac{1}{2} d)$

Standard holes shall be used in bolted connections, except that oversized and slotted holes may be used as approved by the designer. The length of slotted holes shall be normal to the direction of the shear load. Washers or backup plates shall be installed over oversized or short-slotted holes in an outer ply unless suitable performance is demonstrated by load tests in accordance with Section F.

**E3.1 Spacing and Edge Distance**

The distance,  $e$ , measured in the line of force from the center of a standard hole to the nearest edge of an adjacent hole or to the end of the connected part toward which the force is directed shall not be less than the value of  $e_{\min}$  determined as follows:

$$e_{\min} = e \Omega_e \quad (\text{Eq. E3.1-1})$$

**WHERE:**

$$e = \frac{P}{F_u t} \quad (\text{Eq. E3.1-2})$$

(a) When  $F_u/F_{sy} \geq 1.15$ :

$$\begin{aligned} \Omega_e &= \text{Factor of safety for sheet tearing} \\ &= 2.0 \end{aligned}$$

(b) When  $F_u/F_{sy} < 1.15$ :

$$\begin{aligned} \Omega_e &= \text{Factor of safety for sheet tearing} \\ &= 2.22 \end{aligned}$$

**WHERE:**

$P$  = Force transmitted by bolt

$t$  = Thickness of thinnest connected part

$F_u$  = Tensile strength of the connected part as specified in Section A3.1 or A3.2

$F_{sy}$  = Yield point of the connected part as specified in Section A3.1 or A3.2

In addition, the minimum distance between centers of bolt holes shall provide sufficient clearance for bolt heads, nuts, washers and the wrench but shall not be less than 3 times the nominal bolt diameter,  $d$ . Also, the distance from the center of any standard hole to the end or other boundary of the connecting member shall not be less than  $1\frac{1}{2}d$ .

For oversized and slotted holes, the distance between edges of two adjacent holes and the distance measured from the edge of the hole to the end or other boundary of the connecting member in the line of stress shall not be less than the value of  $[e_{\min} - (d_h/2)]$ , in which  $e_{\min}$  is the required distance computed from the applicable equation given above, and  $d_h$  is the diameter of a standard hole defined in Table E3. In no case shall the clear distance between edges of two adjacent holes be less than  $2d$  and the distance between the edge of the hole and the end of the member be less than  $d$ .

**E3.2 Tension in Connected Part**

The tension force on the net section of a bolted connection shall not exceed  $T_a$  from Section C2 or  $P_a$  calculated as follows:

$$P_a = P_n / \Omega_t \quad (\text{Eq. E3.2-1})$$

**WHERE:**

$$P_n = A_n F_t$$

$A_n$  = Net section area

$F_t$  and  $\Omega_t$  are determined as follows:

(a) When  $t \geq \frac{3}{16}$  in. (4.8 mm):

See AISC Specification (Reference 3 of Section A6)

(b) When  $t < \frac{3}{16}$  inch (4.8 mm) and washers are provided under both the bolt head and the nut

$$F_t = (1.0 - 0.9r + 3rd/s) F_u \leq F_u \quad (\text{Eq. E3.2-2})$$

$$\begin{aligned} \Omega_t &= \text{Factor of safety for tension on the net section} \\ &= 2.0 \text{ for double shear} \\ &= 2.22 \text{ for single shear} \end{aligned}$$

(c) When  $t < \frac{3}{16}$  inch (4.8 mm) and either washers are not provided under the bolt head and nut, or only one washer is provided under either the bolt head or nut

$$F_t = (1.0 - r + 2.5rd/s) F_u \leq F_u \quad (\text{Eq. E3.2-3})$$

$\Omega_t$  = Factor of safety for tension on the net section  
= 2.22

**WHERE:**

r = Force transmitted by the bolt or bolts at the section considered, divided by the tension force in the member at that section. If r is less than 0.2, it may be taken equal to zero.

s = Spacing of bolts perpendicular to line of stress.

In the case of a single bolt,

s = Width of sheet

$F_t$  = Nominal tension stress limit on net section

$F_u$  = Tensile strength of the connected part as specified in Sections A3.1 or A3.2

d and t are defined in Section E3.1.

**E3.3 Bearing**

The bearing force shall not exceed  $P_a$  calculated as follows:

$$P_a = P_n / \Omega_b \tag{Eq. E3.3-1}$$

**WHERE:**

$$P_n = F_p dt \tag{Eq. E3.3-2}$$

$\Omega_b$  = Safety factor for bearing

= 2.22

$F_p$  = Nominal bearing stress as given in Tables E3.3-1 and E3.3-2.

For conditions not shown, forces shall be determined on the basis of test data using a factor of safety of 2.22.

**TABLE E3.3-1  
Nominal Bearing Stress for Bolted Connections  
with Washers under Both Bolt Head and Nut**

Thickness of connected part, in. × 25.4 for mm	Type of joint	$F_u/F_{sy}$ ratio of connected part	Nominal bearing stress, $F_p$
≥ 0.024 but < $3/16$	Inside sheet of double shear connection	≥ 1.15	3.33 $F_u$
		< 1.15	3.00 $F_u$
	Single shear and outside sheets of double shear connection	No limit	3.00 $F_u$
≥ $3/16$	See AISC Specification (Reference 3 of Section A6)		

**TABLE 3.3-2  
Nominal Bearing Stress for Bolted Connections Without Washers  
Under Both Bolt Head and Nut, or with Only One Washer**

Thickness of connected part, in. × 25.4 for mm	Type of joint	$F_u/F_{sy}$ ratio of connected part	Nominal bearing stress, $F_p$
≥ 0.036 but < $3/16$	Inside sheet of double shear connection	≥ 1.15	3.00 $F_u$
	Single shear and outside sheets of double shear connection	≥ 1.15	2.22 $F_u$
≥ $3/16$	See AISC Specification (Reference 3 of Section A6)		

**E3.4 Shear and Tension in Bolts**

The bolt force resulting from shear, tension or combination of shear and tension shall not exceed allowable bolt force,  $P_a$ , calculated as follows (the factor of safety is included in Tables E3.4-1 and E3.4-2):

$$P_a = A_b F \quad (\text{Eq. E3.4-1})$$

**WHERE:**

$A_b$  = Gross cross-sectional area of bolt

F is given by  $F_v$ ,  $F_t$  or  $F'_t$  in Tables E3.4-1 and E3.4-2.

**TABLE E3.4-1**

Description of Bolts × 25.4 for mm	Allowable Shear Stress*, $F_v$ , ksi × 6.89 for MPa		Allowable Tension Stress, $F_t$ , ksi × 6.89 for MPa
	Threads Not Excluded from Shear Plane	Threads Excluded from Shear Plane	
A325 Bolts	21	30	44
A354 Grade B Bolts ( $1/4$ in. ≤ $d$ < $1/2$ in.)	24	40	49
A449 Bolts ( $1/4$ in. ≤ $d$ < $1/2$ in.)	18	30	40
A490 Bolts	28	40	54
A307 Bolts, Grade A ( $1/4$ in. ≤ $d$ < $1/2$ in.)	9		18
A307 Bolts, Grade A ( $1/4$ in. ≤ $d$ < $1/2$ in.)	10		20

\*Applies to bolts in holes as limited by Table E3. Washers or back-up plates shall be installed over long-slotted holes and the capacity of connections using long-slotted holes shall be determined by load tests in accordance with Section F.

The pullover strength of the connected sheet at the bolt head, nut or washer should be considered where bolt tension is involved. See Section E5.2.

When bolts are subject to a combination of shear and tension, the tension force shall not exceed the allowable force,  $P_a$ , based on  $F'_t$ , given in Table E3.4-2, where  $f_v$ , the shear stress produced by the same forces, shall not exceed the allowable value  $F_v$  given above.

**TABLE E3.4-2**  
**Allowable Tension Stress,  $F'_t$ , for Bolts**  
**Subject to the Combination of Shear and Tension**

Description of Bolts × 25.4 for mm	Threads Not Excluded from Shear Planes × 6.89 for MPa	Threads Excluded from Shear Planes × 6.89 for MPa
A325 Bolts	55 - 1.8 $f_v$ ≤ 44	55 - 1.4 $f_v$ ≤ 44
A354 Grade BD Bolts	61 - 1.8 $f_v$ ≤ 49	61 - 1.4 $f_v$ ≤ 49
A449 Bolts	50 - 1.8 $f_v$ ≤ 40	50 - 1.4 $f_v$ ≤ 40
A490 Bolts	68 - 1.8 $f_v$ ≤ 54	68 - 1.4 $f_v$ ≤ 54
A307 Bolts, Grade A When $1/4$ in. ≤ $d$ < $1/2$ in. When $d$ ≥ $1/2$ in.	23 - 1.8 $f_v$ ≤ 18 26 - 1.8 $f_v$ ≤ 20	

**E4 Shear Rupture**

At beam-end connections, where one or more flanges are coped and failure might occur along a plane through the fasteners, the shear force shall not exceed the allowable shear force  $V_a$ , calculated as follows:

$$V_a = V_n / \Omega_v \quad (\text{Eq. E4-1})$$

**WHERE:**

$$V_n = 0.6 F_u A_{wn} \quad (\text{Eq. E4-2})$$

$$A_{wn} = (d_{wc} - nd_h)t \quad (\text{Eq. E4-3})$$

$d_{wc}$  = Coped web depth

- $n$  = Number of holes in the critical plane  
 $d_h$  = Hole diameter  
 $F_u$  = Tensile strength as specified in Sections A3.1 or A3.2  
 $t$  = Thickness of coped web  
 $\Omega_v$  = Factor of safety for shear rupture  
 = 2.00

## E5 Connections to Other Materials

### E5.1 Bearing

Proper provisions shall be made to transfer bearing forces resulting from axial loads and moments from steel components covered by the Specification to adjacent structural components made of other materials. The bearing force in the contact area shall not exceed the allowable bearing force  $P_a$  calculated as follows:

$$P_a = F_p A$$

#### WHERE:

$A$  = Contact area

$F_p$  = Allowable bearing stress. (The factor of safety is included in values for  $F_p$ .)

In the absence of code regulations for other materials, the following allowable stresses may be used:

$F_p$  = 0.40 ksi (2.76 MPa) on sandstone and limestone

$F_p$  = 0.25 ksi (1.72 MPa) on brick in cement mortar

$F_p$  =  $0.35 f'_c$  on the full area of a concrete support

$F_p$  =  $0.35 f'_c \sqrt{A_2/A_1} \leq 0.7 f'_c$  on less than the full area of a concrete support

#### WHERE:

$f'_c$  = Specified compression strength of concrete

$A_1$  = Bearing area

$A_2$  = Full cross-sectional area of concrete support

### E5.2 Tension

The pull-over shear/tension forces in the steel sheet around the head of the fastener should be considered as well as the pull-out force resulting from axial loads and bending moments transmitted onto the fastener from various adjacent structural components in the assembly.

The allowable tensile strength of the fastener and the allowable imbedment strength of the adjacent structural component shall be determined by applicable product code approvals, or product specifications and/or product literature.

### E5.3 Shear

Proper provisions shall be made to transfer shearing forces from steel components covered by this Specification to adjacent structural components made of other materials. The allowable shear and/or bearing forces on the steel components shall not exceed that allowed by this Specification. The allowable shear force on the fasteners and other material shall not be exceeded. Imbedment requirements are to be met. Proper provision shall also be made for shearing forces in combination with other forces.

## F. TESTS FOR SPECIAL CASES

- (a) Tests shall be made by an independent testing laboratory or by a testing laboratory of a manufacturer.

(b) The provisions of Chapter F do not apply to cold-formed steel diaphragms.

### F1 Tests for Determining Structural Performance

Where the composition or configuration of elements, assemblies, connections, or details of cold-formed steel structural members are such that calculation of their safe load-carrying capacity or deflection cannot be made in accordance with the provisions of this Specification, their structural performance shall be established from tests and evaluated in accordance with the following procedure.

(a) Where practicable, evaluation of tests results shall be made on the basis of the mean values resulting from tests of not fewer than three identical specimens, provided the deviation of any individual test result from the mean value obtained from all tests does not exceed  $\pm 10$  percent. If such deviation from the mean exceeds 10 percent, at least three more tests of the same kind shall be made. The average of the three lowest values of all tests made shall then be regarded as the result of the series of tests.

(b) The required load-carrying capacity shall be:

$$R = D F_D + L F_L \quad (\text{Eq. F1-1})$$

where  $D$  and  $L$  are the dead and live loads, respectively,  $D$  shall include the weight of the test specimen.  $F_D$  and  $F_L$  are the dead and live load factors specified below.  $R$  shall be taken as the largest applicable value determined as follows:

(1) The minimum load-carrying capacity,  $R$ , shall be calculated from the formula

$$R \geq 1.5D + 2L \quad (\text{Eq. F1-2})$$

$R$  shall be multiplied by 1.25 for steels not listed in Section A3.1

$R$  may be divided by  $1\frac{1}{3}$  when the loading consists of wind or earthquake loads alone, or in combination with dead, live, or snow loads, but shall not be less than  $R$  calculated for the combination of dead and live loads only, without wind or earthquake loads.

(2) The load at which distortions interfere with the proper functioning of the specimen in actual use shall not be less than:

$$R \geq D + 1.5L$$

(Eq. F1-3)

(3) The load carrying capacity when limited by connection failure shall not be less than:

$$R \geq 2.5D + 2.5L \quad (\text{Eq. F1-4})$$

(c) If the yield point of the steel from which the tested sections are formed is larger than the specified value, the test results shall be adjusted down to the specified minimum yield point of the steel which the manufacturer intends to use. The test results shall not be adjusted upward if the yield point of the test specimen is less than the minimum specified yield point. Similar adjustments shall be made on the basis of tensile strength instead of yield point where tensile strength is the critical factor.

Consideration must also be given to any variation or differences which may exist between the design thickness and the thickness of the specimens used in the tests.

### F2 Tests for Confirming Structural Performance

The procedures and formulas specified in Section F1 are not applicable to confirmation tests on specimens whose capacities can be computed according to this Specification or its specific references. A successful confirmatory test shall demonstrate a safety factor not less than that implied in the Specification for the type of behavior involved.

### F3 Tests for Determining Mechanical Properties

#### F3.1 Full Section

Tests for determination of mechanical properties of full sections to be used in Section A5.2.2 shall be made as specified below:

(a) Tensile testing procedures shall agree with Standard Methods and Definitions for Mechanical Testing of Steel Products, ASTM A370.

Compressive yield point determinations shall be made by means of compression tests of short specimens of the section.

(b) The comprehensive yield stress shall be taken as the smaller value of either the maximum compressive strength of the sections divided by the cross section area or the stress defined by one of the following methods:

(1) For sharp yielding steel, the yield point shall be determined by the autographic diagram method or by the total strain under load method.

(2) For gradual yielding steel, the yield point shall be determined by the strain under load method or by the 0.2 percent offset method.

When the total strain under load method is used, there shall be evidence that the yield point so determined agrees within 5 percent with the yield point which would be determined by the 0.2 percent offset method.

(c) Where the principal effect of the loading to which the member will be subjected in service will be to produce bending stresses, the yield point shall be determined for the flanges only. In determining such yield points, each specimen shall consist of one complete flange plus a portion of the web of such flat width ratio that the value of  $\rho$  for the specimen is unity.

(d) For acceptance and control purposes, two full section tests shall be made from each lot of not more than 50 tons (45 360 kg) nor less than 30 tons (27 216 kg) of each section, or one test from each lot of less than 30 tons (27 216 kg) of each section. For this purpose, a lot may be defined as that tonnage of one section that is formed in a single production run of material from one heat.

(e) At the option of the manufacturer, either tension or compression tests may be used for routine acceptance and control purposes, provided the manufacturer demonstrates that such tests reliably indicate the yield point of the section when subjected to the kind of stress under which the member is to be used.

### F3.2 Flat Elements of Formed Sections

Tests for determining mechanical properties of flat elements of formed sections and representative mechanical properties of virgin steel to be used in Section A5.2.2 shall be made in accordance with the following provisions:

The yield point of flats,  $F_{yf}$ , shall be established by means of a weighted average of the yield points of standard tensile coupons taken longitudinally from the flat portions of a representative cold-formed member. The weighted average shall be the sum of the products of the average yield point for each flat portion times its cross sectional area, divided by the total area of flats in the cross section. The exact number of such coupons will depend on the shape of the member, i.e., on the number of flats in the cross section. At least one tensile coupon shall be taken from the middle of each flat. If the actual virgin yield point exceeds the specified minimum yield point, the yield point of the flats,  $F_{yf}$ , shall be adjusted by multiplying the test values by the ratio of the specified minimum yield point to the actual virgin yield point.

### F3.3 Virgin Steel

The following provisions apply to steel produced to other than the ASTM Specifications listed in Section A3.1 when used in sections for which the increased yield point of the steel after cold forming shall be computed from the virgin steel properties according to Section A5.2.2. For acceptance and control purposes, at least four tensile specimens shall be taken from each lot as defined in Section F3.1(d) for the establishment of the representative values of the virgin tensile yield point and ultimate strength. Specimens shall be taken longitudinally from the quarter points of the width near the outer end of the coil.

## Division VI—DESIGN STANDARD FOR STEEL STORAGE RACKS

Based on the Specification for the Design, Testing and Utilization of Industrial Steel Storage Racks, 1990 Edition, by the Rack Manufacturers Institute

### SECTION 2231 — GENERAL PROVISIONS

**2231.1 Scope.** This division shall apply to pallet racks, movable shelf racks and stacker-racks made of cold-formed or hot-rolled steel structural members. It shall not apply to other types of racks, such as cantilever racks, drive-in and drive-through racks and rack buildings.

The design of racks not covered by this standard shall be in accordance with the provisions of Section 1630 using the loads as defined in this division.

**EXCEPTION:** The building official may waive the design requirements for storage racks less than or equal to 8 feet (2438 mm) in height.

**2231.2 Definitions.** For the purpose of this division, certain terms are defined as follows:

**FRAMES** are the rigid-connection frames composed of posts and pallet beams in pallet racks, and the upright (trussed) frames.

**MOVABLE-SHELF RACKS** are a type of rack where the shelves are removable and replaceable in multiple locations in the section opening.

**PALLET** is a portable platform on which goods are placed for storage or transportation.

**PALLET GUIDE** is a device to prevent a pallet from sliding off its support beam or rail.

**PALLET RACK** (also **Standard Pallet Rack**) is a rack which utilizes horizontal beams connected to prefabricated upright frames to provide independent, multiple-level storage (usually on either side of an aisle). The horizontal beams support pallets.

**PALLET RACK BEAMS** (also **Shelf Beams**) are horizontal structural members used to support pallets in a rack.

**STACKER RACKS** (also **Stacker Crane Racks**) are a rack arrangement, usually higher than other types of racks, where floor-running storage and retrieval machines are used to shuttle loads. These machines are generally rail mounted and often fully automated and computer controlled.

**STACKER-RACK BEAMS** are horizontal structural members used to support pallets in a stacker rack.

**STEEL STORAGE RACK** is a single or multilevel storage system in single or multi-bays consisting of vertical columns or posts and horizontal beams. Diagonal and horizontal trussed bracing is often used to resist horizontal loads. The beams generally support pallets, and the system may be one of a number of different types (Standard Pallet Rack, Stacker Rack, etc.); see definitions of each type.

**UNIT LOAD** is a standardized load, meaning, for example, pallet load if pallets are used. Also refers to other standardized loads such as barrels which may be stored without pallets.

**2231.3 Materials.** This standard contemplates the use of steel of structural quality as listed in Division I.

Steels not listed in the above provisions are not excluded, provided they conform to the chemical and mechanical requirements of one of the listed specifications or other published specifications which establish their properties and structural suitability; and provided they are subjected by either the producer or the purchaser to analyses, tests and other controls to the extent and in the manner prescribed by one of the two listed specifications, as applicable.

**2231.4 Applicable Design Specifications.** Except as either modified or supplemented herein Division I, shall apply to the design of steel storage racks.

**2231.5 Integrity of Rack Installations.** Individual rack components and assemblies thereof shall comply with this standard.

All rack installations and racks manufactured in conformity with this standard shall display in one or more conspicuous locations a permanent plaque each not less than 50 square inches (32 258 mm<sup>2</sup>) in area and showing the maximum permissible unit load in clear, legible print.

**EXCEPTION:** The building official may waive plaque installation for racks not exceeding 12 feet (3658 mm) in height to top shelf, covering a floor area less than 300 square feet (27.87 m<sup>2</sup>), with a unit load not exceeding 2,500 pounds (11 121 N), and without double stacking on top level.

Load application and rack configuration drawings shall be furnished with each rack installation. The drawings shall present the permissible configurations or limitations as to the maximum number of shelves or rails, the maximum distance between them, and the maximum distance from the floor to the bottom shelf or rail.

The bottom of all posts shall be furnished with bearing plates, according to Section 2236.2. Drive-in, drive-through and stacker racks shall be anchored to the floor by anchor bolts capable of resisting the horizontal shear forces caused by the horizontal and vertical loads on the rack.

The stability of movable-shelf racks shall not be dependent upon movable shelves. Those components which provide stability, such as permanently bolted or welded top shelves and the longitudinal and transverse diagonal bracing, shall be clearly identified on the rack configuration drawings. In specific movable-shelf rack installations where rack height requires it, a conspicuous warning is to be placed in the owner's utilization instruction manual of any restrictions on shelf placement or shelf removal. Such restrictions also are to be permanently posted in locations clearly visible to forklift operators.

Lower portions of posts exposed to damage by forklift trucks or other moving equipment shall have protective devices. If not so protected the rack structure may, at the option of the building official: (1) be designed to maintain its full design load capacity at allowable stresses with the exposed post capacity reduced by one-half, or (2) be designed to maintain its full design load capacity at 50 percent increased allowable stresses with the exposed post assumed to have no carrying capacity.

Where racks are braced against the building structure, the building structure shall be designed for the horizontal and vertical forces listed in Section 2235.1 imposed on the building structure.

Racks shall be installed with a maximum tolerance from the vertical of 1 inch in 10 feet (25.4 mm in 3048 mm) of height. Special conditions may require more restrictive tolerances.

Support of racks by foundations, concrete floor slabs or other means shall be in conformance with Chapter 18.

## **SECTION 2232 — DESIGN PROCEDURES AND DIMENSIONAL LIMITATIONS**

**2232.1 General.** All computations for allowable loads, stresses and deflections shall be in accordance with conventional methods of structural design, and as specified in Section 2231.4, except where modified or supplemented herein. Where adequate methods of design calculations are not available, justification by a testing program acceptable to the building official may be used.

**2232.2 Dimensional Limitations.** The limitations on flat-width ratios and slenderness ratios in Division I and Division V shall apply except for the following conditions:

1. Slenderness limitations shall not be imposed on tension members which do not resist compression forces under any loading condition.
2. The unbraced length of compression or tension members shall be the length between connections to other structural members disposed in the direction of the pertinent radius of gyration, or from such a connection to the nearest attachment to an external fixed structure, such as a floor.

## **SECTION 2233 — ALLOWABLE STRESSES AND EFFECTIVE WIDTHS**

**2233.1 General.** Allowable stresses and effective design widths shall be as specified in Division I and Division V except as provided herein. Allowable stresses for working stress design may be in-

creased one-third when considering wind or earthquake forces either acting alone or when combined with vertical loads.

**2233.2 Perforated Compression Members.** The effect of perforations on the carrying capacity of compression members shall be recognized by modification of the Q-factor. Q-values for perforated compression members shall be determined by stub column tests acceptable to the building official. These members shall be designed in an approved manner. The effects of perforations on the capacity of members may be considered by using the section properties based on the minimum net area.

**2233.3 Torsional-flexural Buckling.** Sections subject to torsional-flexural buckling shall be designed according to Division V.

### SECTION 2234 — PALLET AND STACKER-RACK BEAMS

**2234.1 Allowable Loads.** Where the shape of the cross section permits, allowable loads of pallet-carrying beams shall be determined in accordance with Division I or Division V.

**2234.2 Deflections.** At working load the deflections, including possible deformations in the end connections, shall not exceed 1/180 of the span measured with respect to the beam ends.

**2234.3 Determination by Test.** Where the configuration of the cross section precludes calculation of allowable loads and deflections, determination may be made with a testing program acceptable to the building official.

### SECTION 2235 — FRAME DESIGN

**2235.1 General.** Frames shall be designed for the critical combinations of vertical loads in the most unfavorable positions, horizontal loads as specified in Section 2237.3, and the additional effects of horizontal sway caused by looseness, if any, of the top tie beam to post connections.

**2235.2 Effective Lengths.** Effective lengths based on valid engineering principles shall be used in the design of posts and upright frames.

### SECTION 2236 — CONNECTIONS AND BEARING PLATES

**2236.1 Connections.** Adequate strength of connections to withstand calculated resultant forces and moments, and adequate rigidity where such is required, shall be demonstrated by calculation or by testing in an approved manner.

Beams shall have support connections capable of withstanding an upward force of 1,000 pounds (4448 N) per connection within allowable design values of this code.

For movable-shelf racks, the top shelf and other fixed shelves are to include support connections capable of withstanding an upward force of 1,000 pounds (4448 N) per connection within the allowable design values of this code.

The movable shelves are generally constructed of a set of front and rear longitudinal beams connected to each other rigidly by transverse members. The movable shelves are to be connected in such a way to prevent forward displacement when lifting out the front beam of the shelf.

**2236.2 Bearing Plates.** Provision shall be made to transfer post loads and moments into the floor. Said forces and moments shall be consistent in magnitude, sense and direction with the rack analysis. Allowable bearing stresses on the bottom of base plates shall be determined in accordance with Chapter 19.

### SECTION 2237 — LOADS

**2237.1 Gravity Loads.** Racks shall be designed for dead loads, live loads and unit loads as posted on the rack installation under Section 2231.5.

**2237.2 Vertical Impact.** Unit load-carrying beams, supporting arms, if any, and end connections shall be designed for an additional vertical impact load of 25 percent of one unit load located to produce maximum moments and shears. Impact stresses shall not exceed stresses referenced in Section 2233, nor shall they cause detrimental permanent deformations in connections. When allowable loads are determined by tests, due allowance shall be made for the additional impact load. Impact loads may be omitted when checking beam deflections and designing upright frames, posts and other vertical components.

### 2237.3 Horizontal Loads.

**2237.3.1 General.** All racks shall be designed for the horizontal forces and allowable stresses specified in this standard. These forces shall not cause permanent distortions of connections when subject to test, or permanent residual sway deflections (of the entire rack when subject to full-scale rack tests) larger than 20 percent of the sway deflections measured under the simultaneous action of horizontal and vertical loads.

**2237.3.2 Horizontal stability.** Horizontal stability shall be determined by applying horizontal forces simultaneously at all beam-to-post connections equal to 1.5 percent of the maximum live load plus dead load at the connection. The forces shall be applied separately in each of the two principal directions of the rack and in conjunction with full dead and live loads.

**2237.3.3 Stacker racks or racks wholly or partially supporting moving equipment.** Racks shall be designed for maximum forces and their locations, transmitted from moving equipment to racks, and applicable longitudinal and transverse impact factors due to moving equipment.

Devices acting as bumpers to stop moving equipment shall be considered in the design.

Forces described in this subsection need not act concurrently with those described in Sections 2237.3.2 and 2237.5.1.

**2237.4 Wind Loads.** Outdoor racks exposed to wind shall be designed for the wind loads prescribed by Chapter 16 acting on the horizontal projection of rack plus contents. For stability, consideration shall be given to loading conditions which produce large wind forces combined with small stabilizing gravity forces, such as racks fully loaded, but with unit loads of much smaller weight than the maximum posted unit load.

Forces described in Sections 2237.3.2 and 2237.5.1 need not act concurrently with wind loads. Forces described in Section 2237.3.3 shall act concurrently with wind forces for design purposes.

### 2237.5 Earthquake Loads.

**2237.5.1 General.** Steel storage racks which are not connected to buildings or other structures shall be designed to resist seismic forces in conformance with this standard.

**2237.5.2 Minimum earthquake forces.** The total minimum lateral force shall be determined by the following formula:

$$V = (ZIC/R_w) W$$

#### WHERE:

$C$  =  $1.25 S/T^{2/3}$ . The value of  $C$  need not exceed 2.75 and may be used for any structure without regard to soil type or structure period.  $T$  is the fundamental period of vibration of the rack in seconds in the direction under consideration. Properly substantiated calculations or test data for establishing the period,  $T$ , shall be submitted. The minimum value of  $C/R_w$  shall be 0.075.

$I$  = occupancy importance factor as specified in Table 16-K.

$R_w$  = 6.0 for racks or portions thereof where lateral stability is dependent upon diagonal or x-bracing. Connection for the bracing members shall be capable of developing the required strength of the members.

$R_w$  = 8.0 for racks where the lateral stability is wholly dependent on moment-resistant frame action.

$S$  = the site soil coefficient for soil characteristics given in Table 16-J.

$V$  = total lateral seismic force assumed to act nonconcurrently in the direction of each of the main axes of the rack. For racks having more than two storage levels, the total lateral force,  $V$ , shall be distributed over the height of the rack in accordance with

$$F_i = \frac{VW_i h_i}{\sum_{i=1}^n W_i h_i}$$

in which  $F_i$  is the lateral force applied at level  $i$ ;  $W_i$  is the portion of the total weight,  $W$ , which is assigned to level  $i$ ;  $h_i$  is the height of level  $i$  above the base of the rack; and  $n$  is the total number of storage levels. The lateral force,  $V$ , shall be distributed in proportion to the total weight,  $W$ .

$W$  = weight of rack structure plus contents. Where a number of storage racks are interconnected so there are a minimum of four columns in any direction on each column line designed to resist horizontal forces,  $W$  may be equal to the total dead load plus 50 percent of the rack-rated capacity. In Seismic Zones 3 and 4, wholesale and retail areas, the 50 percent may only be used when combined with  $C/R_w = 0.50$ .

$Z$  = numerical coefficient dependent upon the zone as determined by Figure 2 in Chapter 16. For locations in Seismic Zone 1,  $Z = 0.075$ . For locations in Seismic Zone 2A,  $Z = 0.150$ . For locations in Seismic Zone 2B,  $Z = 0.200$ . For locations in Seismic Zone 3,  $Z = 0.300$ . For locations in Seismic Zone 4,  $Z = 0.400$ .

Other  $R_w$  values may be considered based on submission of substantiating data.

**2237.6 Storage Racks in Buildings.** Storage racks located in buildings at levels above the ground level, rack buildings or racks which depend upon attachments to buildings or other structures at other than the floor level for their lateral stability, shall be designed to resist earthquake forces that consider the responses of the building and storage rack to earthquake ground motions as specified in Chapter 16, Division III.

#### 2237.7 Other Considerations.

**2237.7.1 Overturning.** In determining overturning moments, the total weight shall be assumed to act at a height equal to 1.15 times the distance from the floor to the actual center of gravity of all the horizontal forces.

Equal safety against an overturning moment shall be provided when only the top level of the rack is loaded, in which case it is to be assumed that the force acts through the center of gravity of the top load.

**2237.7.2 Torsional forces.** Torsional forces shall be considered based on the critical combination of loaded and unloaded storage spaces.

**2237.7.3 Concurrent forces.** Forces described in Sections 2237.3.2, 2237.3.3 and 2237.4, need not be assumed to act concurrently with earthquake loads.

### SECTION 2238 — SPECIAL RACK DESIGN PROVISIONS

**2238.1 Stability of Truss-braced Upright Frames.** The maximum allowable compression stress in the posts of truss-braced upright frames shall be determined from Division I and Division V.

**2238.2 Overturning and Height-to-Depth Ratio.** Overturning shall be based on the critical combination of vertical and horizontal loads. Stabilizing forces provided by anchor bolts to the

floor shall not be considered to resist overturning unless the anchors are specifically designed and installed to resist the uplift forces. Unless all columns are so anchored, the minimum ratio between righting moment and overturning moment shall be 1.5. Sections 2237.4 and 2237.7 shall be considered in the design.

The height-to-depth ratio of a storage rack shall not exceed 6 to 1 measuring to the top of the top-most load unless the rack is anchored or braced externally.

**2238.3 Connections to Buildings.** Connections of racks to buildings, if any, shall be designed and installed to prevent reactions or displacements of the buildings or racks from damaging one another. Section 2237.5 shall be considered.

**Division VII—DESIGN STANDARD FOR STRUCTURAL APPLICATIONS OF  
STEEL CABLES FOR BUILDINGS**

**Based on the *Criteria for Structural Applications of Steel Cables for Buildings*,  
1973 Edition.**

**SECTION 2239 — SCOPE**

This standard is intended to provide for the design, fabrication and erection of cables used as load-carrying members in building structures or parts thereof.

**SECTION 2240 — MATERIAL**

**2240.1 Cables.** Cable shall be either zinc-coated steel structural strand, zinc-coated steel structural wire rope or equivalent.

**2240.2 Poured Zinc Fittings.** Zinc used for attaching fittings shall be at least equal to the grade designated as "high grade."

**SECTION 2241 — LOAD COMBINATIONS FOR SELECTION OF CABLES**

The effective design breaking strength of the cable shall be equal to or greater than the largest value produced by the following cable tension conditions:

- |                        |              |
|------------------------|--------------|
| 1. $2.2 T_1$           | 4. $2.0 T_4$ |
| 2. $1.6 T_1 + 2.7 T_2$ | 5. $2.0 T_5$ |
| 3. $2.2 T_3$           | 6. $2.0 T_6$ |

**WHERE:**

- $T_1$  = net tension in cable due to dead load and prestress.
- $T_2$  = change in cable tension due to the application of live load.
- $T_3$  = net tension in cable due to dead load, prestress and live load.
- $T_4$  = net tension in cable due to dead load, prestress, live load and wind or earthquake.
- $T_5$  = net tension in cable during erection of the structure.
- $T_6$  = net tension in cable due to dead load, prestress and wind.

**SECTION 2242 — DESIGN CONSIDERATIONS**

The design and analysis shall be based on the following considerations, in addition to those mentioned elsewhere in this standard.

1. The effective design breaking strength shall be equal to the specified minimum breaking strength, except that when saddles are used the effective design breaking strength shall be reduced as follows:

RATIO OF SADDLE RADIUS TO STRAND DIAMETER	RATIO OF SADDLE RADIUS TO WIRE ROPE DIAMETER	EFFECTIVE DESIGN BREAKING STRENGTH AS PERCENT OF SPECIFIED MINIMUM BREAKING STRENGTH
20 and over	15 and over	100
19	14	95
18	13	90
15	12	85
16	11	80
15 minimum	10 minimum	75

2. Cables shall be assumed to have no resistance to bending.
3. Elastic stretch of the cables and deformation of the supporting structure shall be taken into account in the design.
4. Displacement resulting from changes in magnitude and position of the load and its effects on cable stresses shall be considered.

#### **SECTION 2243 — DEFLECTIONS**

Cables supporting floors and roofs shall be proportioned with due regard to the deflection produced by the design loads.

Cables supporting floors and roofs shall be so proportioned that the maximum deflection under the combined action of applied loads and cable stretch will not damage the supported structure of finishes.

#### **SECTION 2244 — END FITTINGS, SADDLES AND CLAMPS**

**2244.1 End Fittings.** In general, end fittings for anchored cables shall be designed and attached to develop the breaking strength of the cables.

End fittings shall be so positioned that visual inspection of the fittings and wire rope near the fittings can be accomplished. Such an arrangement shall not provide a collection point for dirt, moisture or other corrosive agents.

**2244.2 Saddles.** Saddles shall be designed with due consideration of bearing pressures, bend radii and groove diameters. All surfaces in contact with cables shall be smooth. The ends of grooves shall be contoured to avoid excessive bending and/or chafing of the cable.

**2244.3 Clamps.** Clamps shall be designed with due consideration of bearing pressures, deflection angles, holding power and groove diameters. All surfaces in contact with cables shall be smooth. All edges that contact the cable shall be sufficiently rounded to suit all conditions of design and erection.

#### **SECTION 2245 — PROTECTIVE COATINGS**

Unless environmental conditions warrant the use of coating with other types of materials, or leaving the cables uncoated, cables shall have protection at least equivalent to Class A zinc coating on all wires as specified in Section 2240.1.

#### **SECTION 2246 — FABRICATION**

**2246.1 General.** Cables for building structures shall be fabricated in accordance with the best current practice.

**2246.2 Splices.** Splicing of finished cables between end fittings shall not be permitted.

**2246.3 Prestretching.** Cables shall be fabricated to achieve the minimum values for the modulus of elasticity specified by the designer.

**2246.4 Cable Length Measurements.** Length measurements shall be made under loadings specified by the designer.

**2246.5 Striping.** Cables shall be longitudinally striped while under the specified loadings established for length measurement.

#### **SECTION 2247 — ERECTION**

**2247.1 Bracing.** Temporary bracing shall be introduced wherever necessary to accommodate all loads to which the structure may be subjected during construction, including erection equipment and the operation of same. Such bracing shall be left in place as long as may be required for safety.

**2247.2 Adequacy of Temporary Connections.** As erection progresses, temporary connections shall be adequate for the most severe combinations of loads that may be encountered.

**2247.3 Cable Installation.** Care shall be exercised during erection to avoid damaging the cables and their coatings.

Each cable shall be positioned such that the relative turns from one end socket to the other end socket (external turns) are a maximum of 10 degrees. This will establish the theoretical position of the longitudinal stripe line as the line from striped end socket to striped end socket. At any cross section between sockets, the maximum turns of a point on the actual stripe line relative to a point on the theoretical position of the stripe line shall be  $\pm 90$  degrees (internal turns).

Fittings fastened to intermediate points along the cable shall be fastened to the cable in a position within a 10-degree turn from the actual stripe line. A positive twist may be induced in the cable as the fitting is positioned to the structure.

**2247.4 Intermediate Fittings.** Intermediate fittings shall be designed and attached in a manner to prevent damage to the cable.

**2247.5 Permanent Fittings Attached in the Field.** When permanent fittings are attached to cables in the field, the work shall be performed in accordance with the suggestions of the cable manufacturer.

**Division VIII—DESIGN STANDARD FOR LOAD AND RESISTANCE FACTOR  
DESIGN FOR STRUCTURAL STEEL BUILDINGS****Based on Load and Resistance Factor Design Specification  
for Structural Steel Buildings of the  
American Institute of Steel Construction, Inc.****(September 1, 1986, with Supplement No. 1, January 1, 1989)**

Section 2248 of this division contains the exceptions to the referenced specification. Section 2249 of this division is "Load and Resistance Factor Design Specification for Structural Steel Buildings" and Supplement No. 1, reproduced with permission of the publisher.

**NOTE:** 1 Pa = 1 N/m<sup>2</sup>, 1 MPa = 1 N/mm<sup>2</sup>

**SECTION 2248 — SCOPE**

The American Institute of Steel Construction specification adopted by this division applies to the design, fabrication, erection and quality control of structural steel except as modified by this part. Where other codes, standards or specifications are referred to in this standard, they are to be considered as only an indication of an acceptable method or material that can be used with the approval of the building official.

**1. Appendices.** Appendices Sections B5 Local Buckling, E3 Columns and Other Compression Members, F1 Design for Flexure, F4 Web-tapered Members, G Plate Girders, H3 Members under Torsion and Combined Forces, K2 Ponding and K4 Fatigue are specifically adopted and made a part of this standard.

**2. Sec. A1 is amended as follows:**

This standard is intended as an alternative to Division IX.

**3. Sec. A2.1 is amended by changing the last sentence as follows:**

For the design of cold-formed steel structural members, which profiles contain rounded corners and slender flat elements, the provisions of Divisions V and X shall apply. (Note: If the proposed Division X, based on AISI "Load and Resistance Factor Design for Cold-formed Steel Structural Members," is adopted, this cross-reference should be added.)

**4. Sec. A4 is amended as follows:**

The nominal loads shall be the minimum design loads required by the code, and the load combinations shall be as specified in Section A4.1.

**5. Sec. A6 is amended further by substituting "Division IV" for Research Council for Structural Connections "Specifications for Structural Joints Using ASTM A 325 or A 490 Bolts."**

**SECTION 2249 — ADOPTION**

Reproduced with permission from the American Institute of Steel Construction, 1 East Wacker Drive, Suite 3100, Chicago, Illinois 60601. Persons desiring to reprint in whole or in part any portion of this specification must secure permission from the American Institute of Steel Construction, Inc.

## TABLE OF CONTENTS

### NOMENCLATURE

#### A. GENERAL PROVISIONS

##### A1. Scope (Modified per Section 2248)

##### A2. Limits of Applicability

1. Structural Steel Defined (Modified per Section 2248)
2. Types of Construction

##### A3. Material

1. Structural Steel
2. Steel Castings and Forgings
3. Bolts
4. Anchor Bolts and Threaded Rods
5. Filler Metal and Flux for Welding
6. Stud Shear Connectors

##### A4. Loads and Load Combinations (Modified per Section 2248)

1. Loads, Load Factors and Load Combinations
2. Impact
3. Crane Runway Horizontal Forces

##### A5. Design Basis

1. Required Strength at Factored Loads
2. Limit States
3. Design for Strength
4. Design for Serviceability and Other Considerations

##### A6. Referenced Codes and Standards (Modified per Section 2248)

##### A7. Design Documents

1. Plans
2. Standard Symbols and Nomenclature
3. Notation for Welding

#### B. DESIGN REQUIREMENTS

##### B1. Gross Area

##### B2. Net Area

##### B3. Effective Net Area

##### B4. Stability

##### B5. Local Buckling

1. Classification of Steel Sections
2. Sections for Plastic Analysis
3. Slender Compression Elements

##### B6. Bracing at Supports

##### B7. Limiting Slenderness Ratios

#### C. FRAME AND OTHER STRUCTURES

##### C1. Second Order Effects

##### C2. Frame Stability

1. Braced Frames
2. Unbraced Frames

**D. TENSION MEMBERS**

- D1. Design Tensile Strength**
- D2. Built-up Members**
- D3. Eyebars and Pin-connected Members**

**E. COLUMNS AND OTHER COMPRESSION MEMBERS**

- E1. Effective Length and Slenderness Limitations**
  - 1. Effective Length
  - 2. Plastic Analysis
- E2. Design Compressive Strength**
- E3. Flexural-torsional Buckling**
- E4. Built-up Members**
- E5. Pin-connected Compression Members**

**F. BEAMS AND OTHER FLEXURAL MEMBERS**

- F1. Design for Flexure**
  - 1. Unbraced Length for Plastic Analysis
  - 2. Flexural Design Strength
  - 3. Compact Section Members with  $L_b \leq L_r$
  - 4. Compact Section Members with  $L_b > L_r$
  - 5. Tees and Double-angle Beams
  - 6. Noncompact Plate Girders
  - 7. Nominal Flexural Strength of Other Sections
- F2. Design for Shear**
  - 1. Web Area Determination
  - 2. Design Shear Strength
- F3. Transverse Stiffeners**
- F4. Web-tapered Members (see Appendix F4)**

**G. PLATE GIRDERS****H. MEMBERS UNDER TORSION AND COMBINED FORCES**

- H1. Symmetric Members Subject to Bending and Axial Force**
  - 1. Doubly and Singly Symmetric Members in Flexure and Tension
  - 2. Doubly and Singly Symmetric Members in Flexure and Compression
- H2. Unsymmetric Members and Members under Torsion and Combined Torsion, Flexure and/or Axial Force**
- H3. Alternate Interaction Equations for Members under Combined Stress (see Appendix H3)**

**I. COMPOSITE MEMBERS**

- I1. Design Assumptions**
- I2. Compression Members**
  - 1. Limitations
  - 2. Design Strength
  - 3. Columns with Multiple Steel Shapes
  - 4. Load Transfer
- I3. Flexural Members**
  - 1. Effective Width

2. Strength of Beams with Shear Connectors
3. Strength of Concrete-encased Beams
4. Strength during Construction
5. Formed Steel Deck
6. Design Shear Strength

**I4. Combined Compression and Flexure**

**I5. Shear Connectors**

1. Materials
2. Horizontal Shear Force
3. Strength of Stud Shear Connectors
4. Strength of Channel Shear Connectors
5. Required Number of Shear Connectors
6. Shear Connector Placement and Spacing

**I6. Special Cases**

**J. CONNECTIONS, JOINTS AND FASTENERS**

**J1. General Provisions**

1. Design Basis
2. Simple Connections
3. Moment Connections
4. Compression Members with Bearing Joints
5. Minimum Strength of Connections
6. Placement of Welds and Bolts
7. Bolts in Combination with Welds
8. High-strength Bolts in Combination with Rivets
9. Limitations on Bolted and Welded Connections

**J2. Welds**

1. Groove Welds
2. Fillet Welds
3. Plug and Slot Welds
4. Design Strength
5. Combination of Welds
6. Matching Steel

**J3. Bolts, Threaded Parts and Rivets**

1. High-strength Bolts
2. Effective Bearing Area
3. Design Tension or Shear Strength
4. Combined Tension and Shear in Bearing-type Connections
5. High-strength Bolts in Slip-critical Joints
6. Bearing Strength at Bolt Holes
7. Size and Use of Holes
8. Long Grips
9. Minimum Spacing
10. Minimum Edge Distance
11. Maximum Edge Distance and Spacing

**J4. Design Shear Rupture Strength**

**J5. Connecting Elements**

1. Eccentric Connections
2. Design Strength of Connecting Elements

**J6. Fillers****J7. Splices****J8. Bearing Strength**

1. Milled or Finished Surfaces
2. Expansion Rollers and Rockers

**J9. Column Bases and Bearing on Concrete****J10. Anchor Bolts and Embedments**

1. Anchor Bolts
2. Embedments
3. Prestressed Embedments

**K. STRENGTH DESIGN CONSIDERATIONS****K1. Webs and Flanges with Concentrated Forces**

1. Design Basis
2. Local Flange Bending
3. Local Web Yielding
4. Web Crippling
5. Sidesway Web Buckling
6. Compression Buckling of the Web
7. Compression Members with Web Panels Subject to High Shear
8. Stiffener Requirements for Concentrated Loads

**K2. Ponding****K3. Torsion****K4. Fatigue****L. SERVICEABILITY DESIGN CONSIDERATIONS****L1. Camber****L2. Expansion and Contraction****L3. Deflections, Vibration and Drift**

1. Deflections
2. Vibration
3. Drift

**L4. Connection Slip (see Section J3.5)****L5. Corrosion****M. FABRICATION, ERECTION AND QUALITY CONTROL****M1. Shop Drawings****M2. Fabrication**

1. Cambering, Curving and Straightening
2. Thermal Cutting
3. Planning of Edges
4. Welded Construction
5. Bolted Construction
6. Compression Joints

7. Dimensional Tolerances
8. Finishing of Column Bases

**M3. Shop Painting**

1. General Requirements
2. Inaccessible Surfaces
3. Contact Surfaces
4. Finished Surfaces
5. Surfaces Adjacent to Field Welds

**M4. Erection**

1. Alignment of Column Bases
2. Bracing
3. Alignment
4. Fit of Column Compression Joints
5. Field Welding
6. Field Painting
7. Field Connections

**M5. Quality Control**

1. Cooperation
2. Rejections
3. Inspection of Welding
4. Inspection of Slip-critical High-strength Bolted Connections
5. Identification of Steel

**B. APPENDICES**

**B. DESIGN REQUIREMENTS**

**B5. Local Buckling**

3. Slender Compression Elements

**E. COLUMNS AND OTHER COMPRESSION MEMBERS**

**E3. Flexural-torsional Buckling**

**F. BEAMS AND OTHER FLEXURAL MEMBERS**

**F1. Design for Flexure**

7. Nominal Flexural Strength of Other Sections

**F4. Web-tapered Members**

1. General Requirements
2. Design Tensile Strength
3. Design Compressive Strength
4. Design Flexural Strength
5. Design Shear Strength
6. Combined Flexure and Axial Force

**G. PLATE GIRDERS**

**G1. Limitations**

**G2. Design Flexural Strength**

**G3. Design Shear Strength with Tension Field Action**

**G4. Transverse Stiffeners**

**G5. Flexure-shear Interaction**

**H. MEMBERS UNDER TORSION AND COMBINED FORCES**

**H3. Alternate Interaction Equations for Members under Combined Stress**

**K. STRENGTH DESIGN CONSIDERATIONS****K2. Ponding****K4. Fatigue**

1. Loading Conditions; Type and Location of Material
2. Design Stress Range
3. Design Strength of Bolts in Tension

**NUMERICAL VALUES****NOMENCLATURE**

The section number in parentheses after the definition of a symbol refers to the section where the symbol is first defined.

$A$	Cross-sectional area, in. <sup>2</sup> (mm <sup>2</sup> ) (F1.3)
$A_B$	Loaded area of concrete, in. <sup>2</sup> (mm <sup>2</sup> ) (I2.4)
$A_b$	Nominal body area of a fastener, in. <sup>2</sup> (mm <sup>2</sup> ) (J3.4)
$A_b$	Area of an upset rod based on the major diameter of its threads, in. <sup>2</sup> (mm <sup>2</sup> ) (J3.3)
$A_c$	Area of concrete, in. <sup>2</sup> (mm <sup>2</sup> ) (I2.2)
$A_c$	Area of concrete slab within effective width, in. <sup>2</sup> (mm <sup>2</sup> ) (I5.2)
$A_e$	Effective net area, in. <sup>2</sup> (mm <sup>2</sup> ) (I2.2)
$A_f$	Area of flange, in. <sup>2</sup> (mm <sup>2</sup> ) (Appendix F4)
$A_g$	Gross area, in. <sup>2</sup> (mm <sup>2</sup> ) (B1)
$A_n$	Net area, in. <sup>2</sup> (mm <sup>2</sup> ) (B2)
$A_{ns}$	Net area subject to shear, in. <sup>2</sup> (mm <sup>2</sup> ) (J4)
$A_{pb}$	Projected bearing area, in. <sup>2</sup> (mm <sup>2</sup> ) (D3, J8.1)
$A_r$	Area of reinforcing bars, in. <sup>2</sup> (mm <sup>2</sup> ) (I2.2)
$A_s$	Area of steel cross section, in. <sup>2</sup> (mm <sup>2</sup> ) (I2.2, I5.2)
$A_{sc}$	Cross-sectional area of stud shear connector, in. <sup>2</sup> (mm <sup>2</sup> ) (I5.3)
$A_{sf}$	Shear area on the failure path, in. <sup>2</sup> (mm <sup>2</sup> ) (D3)
$A_w$	Web area, in. <sup>2</sup> (mm <sup>2</sup> ) (F2.1)
$A_1$	Area of steel bearing concentrically on a concrete support, in. <sup>2</sup> (mm <sup>2</sup> ) (J9)
$A_2$	Total cross-sectional area of a concrete support, in. <sup>2</sup> (mm <sup>2</sup> ) (J9)
$B$	Factor for bending stress in web-tapered members, in. (mm), defined by Formulas A-F4-7 through A-F4-10 (Appendix F4)
$B_1, B_2$	Factors used in determining $M_u$ for combined bending and axial forces when first order analysis is employed (H1)
$C_b$	Bending coefficient dependent on moment gradient (F1.3)
$C_m$	Coefficient applied to bending term in interaction formula for prismatic members and dependent on column curvature caused by applied moments (H1)
$C'_m$	Coefficient applied to bending term in interaction formula for tapered members and dependent on axial stress at the small end of the member (Appendix F4)
$C_p$	Ponding flexibility coefficient for primary member in a flat roof (K2)
$C_{PG}$	Plate girder coefficient (Appendix G2)
$C_s$	Ponding flexibility coefficient for secondary member in a flat roof (K2)
$C_v$	Ratio of "critical" web stress, according to linear buckling theory, to the shear yield stress of web material (Appendix G4)

$C_w$	Warping constant, in. <sup>6</sup> (mm <sup>6</sup> ) (F1.3)
$D$	Outside diameter of circular hollow section, in. (mm) (Appendix B5.3)
$D$	Dead load due to the self-weight of the structural and permanent elements on the structure (A4.1)
$D$	Factor used in Formula A-G4-2, dependent on the type of transverse stiffeners used in a plate girder (Appendix G4)
$E$	Modulus of elasticity of steel [29,000 ksi (200 000 N/mm <sup>2</sup> )] (E2)
$E$	Earthquake load (A4.1)
$E_c$	Modulus of elasticity of concrete, ksi (N/mm <sup>2</sup> ) (I2.2)
$E_m$	Modified modulus of elasticity, ksi (N/mm <sup>2</sup> ) (I2.2)
$F_{BM}$	Nominal strength of the base material to be welded, ksi (N/mm <sup>2</sup> ) (J2.4)
$F_{EXX}$	Classification strength of weld metal, ksi (N/mm <sup>2</sup> ) (A3.5 and J2.4)
$F_a$	Axial design strength, ksi (N/mm <sup>2</sup> ) (A5.1)
$F_{b\gamma}$	Flexural stress for tapered members defined by Formulas A-F4-4 and A-F4-5 (Appendix F4)
$F_{cr}$	Critical stress, ksi (N/mm <sup>2</sup> ) (E2)
$F_e$	Elastic buckling stress, ksi (N/mm <sup>2</sup> ) (Appendix E3)
$F_{ex}$	Elastic flexural buckling stress about the major axis, ksi (N/mm <sup>2</sup> ) (Appendix E3)
$F_{ey}$	Elastic flexural buckling stress about the minor axis, ksi (N/mm <sup>2</sup> ) (Appendix E3)
$F_{ez}$	Elastic torsional buckling stress about the major axis, ksi (N/mm <sup>2</sup> ) (Appendix E3)
$F_{my}$	Modified yield stress for composite columns, ksi (N/mm <sup>2</sup> ) (I2.2)
$F_n$	Nominal shear rupture strength, ksi (N/mm <sup>2</sup> ) (J4)
$F_r$	Compressive residual stress in flange, ksi (N/mm <sup>2</sup> ) (F1.3)
$F_{\gamma g}$	Stress for tapered members defined by Formula A-F4-4 (Appendix F4)
$F_u$	Specified minimum tensile strength of the type of steel being used, ksi (N/mm <sup>2</sup> ) (D1)
$F_w$	Nominal strength of the weld electrode material, ksi (N/mm <sup>2</sup> ) (J2.4)
$F_{wg}$	Stress for tapered members defined by Formula A-F4-7, ksi (N/mm <sup>2</sup> ) (J2.4)
$F_y$	Specified minimum yield stress of the type of steel being used, ksi (N/mm <sup>2</sup> ). As used in this specification, "yield stress" denotes either the specified minimum yield point (for those steels that have a yield point) or specified yield strength (for those steels that do not have a yield point)
$F_{yf}$	Specified minimum yield stress of the flange, ksi (N/mm <sup>2</sup> ) (B5.1)
$F_{ym}$	Yield stress obtained from mill test reports or from physical tests, ksi (N/mm <sup>2</sup> ) (N2)
$F_{yr}$	Specified minimum yield stress of reinforcing bars, ksi (N/mm <sup>2</sup> ) (I2.2)
$F_{ys}$	Static yield stress, ksi (N/mm <sup>2</sup> ) (N2)
$F_{yst}$	Specified minimum yield stress of the stiffener material, ksi (N/mm <sup>2</sup> ) (Appendix G4)
$F_{yw}$	Specified minimum yield stress of the web, ksi (N/mm <sup>2</sup> ) (F2.2)
$G$	Shear modulus of elasticity of steel, ksi (N/mm <sup>2</sup> ) [ $G = 11,200$ ksi ( $G = 77\,000$ N/mm <sup>2</sup> )] (F1.3)
$H$	Horizontal force, kips (N) (H1.2)
$H_s$	Length of stud connector after welding, in. (mm) (I3.5)
$I$	Moment of inertia, in. <sup>4</sup> (mm <sup>4</sup> )
$I_d$	Moment of inertia of the steel deck supported on secondary members, in. <sup>4</sup> (mm <sup>4</sup> ) (K2)
$I_p$	Moment of inertia of primary members, in. <sup>4</sup> (mm <sup>4</sup> ) (K2)
$I_s$	Moment of inertia of secondary members, in. <sup>4</sup> (mm <sup>4</sup> ) (K2)
$I_{st}$	Moment of inertia of a transverse stiffener, in. <sup>4</sup> (mm <sup>4</sup> ) (Appendix G4)

$J$	Torsional constant for a section, in. <sup>4</sup> (mm <sup>4</sup> ) (F1.3)
$K$	Effective length factor for prismatic member (C2)
$K_s$	Slip coefficient (J3)
$K_z$	Effective length factor for torsional buckling (Appendix E3)
$K_\gamma$	Effective length factor for a tapered member (Appendix F4.3)
$L$	Unbraced length of member measured between the center of gravity of the bracing members, in. (E2)
$L$	Story height, in. (mm) (H1.2)
$L$	Distance in line of force from center of a standard or oversized hole or from the center of the end of a slotted hole to an edge of a connected part, in. (mm) (J3.6)
$L$	Live load due to occupancy (A4.1)
$L_b$	Laterally unbraced length; length between points which are either braced against lateral displacement of compression flange or braced against twist of the cross section, in. (mm) (F1.1)
$L_c$	Length of channel shear connector, in. (mm) (I5.4)
$L_p$	Limiting laterally unbraced length for full plastic bending capacity, uniform moment case ( $C_b = 1.0$ ), in. (mm) (F1.3)
$L_p$	Column spacing in direction of girder, in. (mm) (K2)
$L_{pd}$	Limiting laterally unbraced length for plastic analysis, in. (mm) (F1.1)
$L_r$	Limiting laterally unbraced length for inelastic lateral-torsional buckling, in. (mm) (F1.3)
$L_r$	Roof live load (A4.1)
$L_s$	Column spacing perpendicular to direction of girder, in. (mm) (K2)
$M_1$	Smaller moment at end of unbraced length of beam or beam-column, kip-in. (N·m) (F1.1)
$M_2$	Larger moment at end of unbraced length of beam or beam-column, kip-in. (N·m) (F1.3)
$M_{cr}$	Elastic buckling moment, kip-in. (N·m) (F1.4)
$M_{lt}$	Required flexural strength in member due to lateral frame translation, kip-in. (N·m) (H1)
$M_n$	Nominal flexural strength, kip-in. (N·m) (F1.2)
$M'_{nx},$ $M'_{ny}$	Flexural strength defined in Formulas A-H3-7 and A-H3-8 for use in alternate interaction equations for combined bending and axial force, kip-in. (N·m) (Appendix H3)
$M_{nt}$	Required flexural strength in member assuming there is no lateral translation of the frame, kip-in. (N·m) (H1)
$M_p$	Plastic bending moment, kip-in. (N·m) (F1.1)
$M'_p$	Moment defined in Formulas A-H3-5 and A-H3-6, for use in alternate interaction equations for combined bending and axial force, kip-in. (N·m) (Appendix H3)
$M_r$	Limiting buckling moment, $M_{cr}$ , when $\lambda = \lambda_r$ and $C_b = 1.0$ , kip-in. (N·m) (F1.3)
$M_u$	Required flexural strength, kip-in. (N·m) (H1)
$N$	Length of bearing, in. (mm) (K1.3)
$N_r$	Number of stud connectors in one rib at a beam intersection (I3.5)
$P$	Force transmitted by one fastener to the critical connected part, kips (N) (J3.9)
$P_e$	Euler buckling strength, kips (N) (H1)
$P_e$	Elastic buckling load, kips (N) (I4)
$P_n$	Nominal axial strength (tension or compression), kips (N) (D1)
$P_p$	Bearing load on concrete, kips (N) (J9)
$P_u$	Required axial strength (tension or compression), kips (N) (H1)
$P_y$	Yield strength, kips (N) (B5.1)

$Q$	Full reduction factor for slender compression elements (Appendix E3)
$Q_a$	Reduction factor for slender stiffened compression elements (Appendix B5)
$Q_n$	Nominal strength of one stud shear connector, kips (N) (I5)
$Q_s$	Reduction factor for slender unstiffened compression elements (Appendix B5.3)
$R$	Nominal load due to initial rainwater or ice exclusive of the ponding contribution (A4.1)
$R_{PG}$	Plate girder bending strength-reduction factor (Appendix G)
$R_e$	Hybrid girder factor (Appendix F1.7)
$R_n$	Nominal resistance (A5.3)
$R_v$	Web shear strength, kips (N) (K1.7)
$S$	Elastic section modulus, in. <sup>3</sup> (mm <sup>3</sup> )
$S$	Spacing of secondary members, in. (mm) (K2)
$S$	Snow load (A4.1)
$S'_x$	Elastic section modulus of larger end of tapered member about its major axis, in. <sup>3</sup> (mm <sup>3</sup> ) (Appendix F4)
$(S_x)_{eff}$	Effective section modulus about major axis, in. <sup>3</sup> (mm <sup>3</sup> ) (Appendix F1.7)
$S_{xt}, S_{xc}$	Elastic section modulus referred to tension and compression flanges, respectively, in. <sup>3</sup> (mm <sup>3</sup> ) (Appendix G2)
$T$	Required tension force, kips (N) (J3.5)
$T$	Factored applied tension force per bolt, kips (N) (J3.5)
$T_b$	Specified pretension load in high-strength bolt, kips (N) (J3.5)
$U$	Reduction coefficient, used in calculating effective net area (B3)
$V$	Shear force, kips (N) (J10.2)
$V_n$	Nominal shear strength, kips (N) (F2.2)
$V_u$	Required shear strength, kips (N) (Appendix G4)
$W$	Wind load (A4.1)
$X_1$	Beam buckling factor defined by Formula F1-8 (F1.3)
$X_2$	Beam buckling factor defined by Formula F1-9 (F1.3)
$Z$	Plastic section modulus, in. <sup>3</sup> (mm <sup>3</sup> )
$a$	Clear distance between transverse stiffeners, in. (mm) (F2.2)
$a$	Distance between connectors in a built-up member, in. (mm) (E4)
$a$	Shortest distance from edge of pin hole to edge of member measured parallel to direction of force, in. (mm) (D3)
$a_r$	Ratio of web area to compression flange area (Appendix G2)
$b$	Compression element width (Table B5.1)
$b_e$	Reduced effective width for slender compression elements, in. (mm) (Appendix B5.3)
$b_{eff}$	Effective edge distance, in. (mm) (D3)
$b_f$	Flange width, in. (mm) (K1.5)
$c_1, c_2, c_3$	Numerical coefficients (I2.2)
$d$	Nominal fastener diameter, in. (mm) (J3.6)
$d$	Overall depth of member, in. (mm) (F2.1)
$d$	Pin diameter, in. (mm) (D3)
$d$	Roller diameter, in. (mm) (J8.2)
$d_L$	Depth at larger end of unbraced tapered segment, in. (mm) (Appendix F4)
$d_c$	Web depth clear of fillets, in. (mm) (K1.5)
$d_h$	Diameter of a standard size hole, in. (mm) (J3.9)

$d_o$	Depth at smaller end of unbraced tapered segment, in. (mm) (Appendix F4)
$e$	Base of natural logarithm = 2.71828. . .
$f$	Computed compressive stress in the stiffened element, ksi (N/mm <sup>2</sup> ) (Appendix B5.3)
$f_a$	Computed axial stress in column, ksi (N/mm <sup>2</sup> ) (A5.1)
$f_{b1}$	Smallest computed bending stress at one end of a tapered segment, ksi (N/mm <sup>2</sup> ) (Appendix F4)
$f_{b2}$	Largest computed bending stress at one end of a tapered segment, ksi (N/mm <sup>2</sup> ) (Appendix F4)
$f'_c$	Specified compressive strength of concrete, ksi (N/mm <sup>2</sup> ) (I2.2)
$f_o$	Stress due to $1.2D + 1.2R$ , ksi (N/mm <sup>2</sup> ) (Appendix K2)
$f_t$	Computed tension stress in bolts or rivets, ksi (N/mm <sup>2</sup> ) (J3.4)
$f_{un}$	Required normal stress, ksi (N/mm <sup>2</sup> ) (H2)
$f_{uv}$	Required shear stress, ksi (N/mm <sup>2</sup> ) (H2)
$f_v$	Computed shear stress in bolts or rivets, ksi (N/mm <sup>2</sup> ) (J3.4)
$g$	Transverse center-to-center spacing (gage) between fastener gage lines, in. (mm) (B2)
$g$	Acceleration due to gravity = 32.2 ft./sec. <sup>2</sup> (9.8 m/s <sup>2</sup> ) (A4.3)
$h$	Clear distance between flanges less the fillet or corner radius for rolled shapes; and for built-up sections, the distance between adjacent lines of fasteners or the clear distance between flanges when welds are used, in. (mm) (B5.1)
$h_c$	Assumed web depth for stability, in. (mm) (B5.1)
$h_r$	Nominal rib height, in. (mm) (I3.5)
$h_s$	Factor used in Formula A-F4-6 for web-tapered members (Appendix F4.3)
$h_w$	Factor used in Formula A-F4-7 for web-tapered members (Appendix F4.3)
$j$	Factor defined by Formula F3-1 for minimum moment of inertia for a transverse stiffener (F3)
$k$	Web plate buckling coefficient (F2.2)
$k$	Distance from outer face of flange to web toe of fillet, in. (mm) (K1.3)
$l$	Largest laterally unbraced length along either flange at the point of load, in. (mm) (K1.5)
$l$	Length of bearing, in. (mm) (J8.2)
$m$	Ratio of web to flange yield stress or critical stress in hybrid beams (Appendix G2)
$r$	Governing radius of gyration, in. (mm) (E2)
$r_i$	Minimum radius of gyration of individual component in a built-up member, in. (mm) (E4)
$r_T$	Radius of gyration of compression flange plus one third of the compression portion of the web taken about an axis in the plane of the web, in. (mm) (Appendix F1.7)
$r_{T_o}$	Radius of gyration, $r_T$ , for the smaller end of a tapered member, in. (mm) (Appendix F4.3)
$r_m$	Radius of gyration of the steel shape, pipe or tubing in composite columns. For steel shapes it may not be less than 0.3 times the overall thickness of the composite section, in. (mm) (I2)
$\bar{r}_o$	Polar radius of gyration about the shear center, in. (mm) (Appendix E3)
$r_{ox}, r_{oy}$	Radius of gyration about $x$ and $y$ axes at the smaller end of a tapered member, respectively, in. (mm) (Appendix F4.3)
$r_x, r_y$	Radius of gyration about $x$ and $y$ axes, respectively, in. (mm) (F1.1, E3)
$s$	Longitudinal center-to-center spacing (pitch) of any two consecutive holes, in. (mm) (B2)
$t$	Thickness of connected part, in. (mm) (J3.6)
$t$	Thickness of the critical part, in. (mm) (J3.9)
$t_f$	Flange thickness, in. (mm) (B5.1)

$t_f$	Flange thickness of channel shear connector, in. (mm) (I5.4)
$t_w$	Web thickness of channel shear connector, in. (mm) (I5.4)
$t_w$	Web thickness, in. (mm) (F2.1)
$w$	Plate width; distance between welds, in. (mm) (B3)
$w$	Unit weight of concrete, lbs./cu. ft. (N/m <sup>3</sup> ) (I2)
$w_r$	Average width of concrete rib or haunch, in. (mm) (I3.5)
$x$	Subscript relating symbol to strong axis bending
$x_o, y_o$	Coordinates of the shear center with respect to the centroid, in. (mm) (Appendix E3)
$y$	Subscript relating symbol to weak axis bending
$z$	Distance from the smaller end of tapered member used in Formula A-F4-1 for the variation in depth, in. (mm) (Appendix F4)
$\Delta_{oh}$	Translation deflection of the story under consideration, in. (mm) (H1)
$\gamma$	Depth tapering ratio (Appendix F4) Subscript for tapered members (Appendix F4)
$\zeta$	Exponent for alternate beam-column interaction equation (Appendix H3)
$\eta$	Exponent for alternate beam-column interaction equation (Appendix H3)
$\lambda_c$	Column slenderness parameter (E2)
$\lambda_e$	Equivalent slenderness parameter (Appendix E3)
$\lambda_{eff}$	Effective slenderness ratio defined by Formula A-F4-2 (Appendix F4)
$\lambda_p$	Limiting slenderness parameter for compact element (B5.1)
$\lambda_r$	Limiting slenderness parameter for noncompact element (B5.1)
$\mu$	Coefficient of friction (J10.2)
$\phi$	Resistance factor (A5.3)
$\phi_b$	Resistance factor for flexure (B1)
$\phi_c$	Resistance factor for compression (E2)
$\phi_c$	Resistance factor for axially loaded composite columns (I2.2)
$\phi_{sf}$	Resistance factor for shear on the failure path (D3)
$\phi_t$	Resistance factor for tension (D1)
$\phi_v$	Resistance factor for shear (F2.2)

## CHAPTER A

### GENERAL PROVISIONS

#### A1. SCOPE

Modified per Part I.

This standard is intended as an alternative to Chapter 22, Division IX.

#### A2. LIMITS OF APPLICABILITY

##### 1. Structural Steel Defined. Modified per Part I.

As used in this Specification, the term *structural steel* refers to the steel elements of the structural steel frame essential to the support of the design loads. Such elements are generally enumerated in Section 2.1 of the AISC *Code of Standard Practice for Steel Buildings and Bridges*, 1986. For the design of cold-formed steel structural members, which profiles contain rounded corners and slender flat elements, the provisions of Chapter 22, Division V, shall apply.

**2. Types of Construction.** Two basic types of construction and associated design assumptions are permissible under the conditions stated herein, and each will govern in a specific manner the size of members and the types and strength of their connections. Both types must comply with the stability requirements of Section B4.

Type FR (fully restrained), commonly designated as “rigid-frame” (continuous frame), assumes that beam-to-column connections have sufficient rigidity to hold the original angles between intersecting members virtually unchanged.

Type PR (partially restrained) assumes that the connections of beams and girders possess an insufficient rigidity to hold the original angles between intersecting members virtually unchanged.

The design of all connections shall be consistent with assumptions as to type of construction called for on the design drawings.

The FR construction is permitted under the LRFD Specification.

The use of Type PR construction under this Specification depends on the evidence of predictable proportion of full end restraint. Where the connection restraint is ignored, commonly designated “simple framing,” it is assumed that under gravity loads the ends of the beams and girders are connected for shear only and are free to rotate. For “simple framing” the following requirements apply:

- a. The connections and connected members must be adequate to carry the factored gravity loads as “simple beams.”
- b. The connections and connected members shall be adequate to resist the factored lateral loads.
- c. The connections shall have sufficient inelastic rotation capacity to avoid overload of fasteners or welds under combined factored gravity and lateral loading.

When the rotational restraint of the connections is used in the design of the connected members or for the stability of the structure as a whole, the capacity of the connection for such restraint shall be established by analytical or empirical means.

Type PR construction may necessitate some inelastic, but self-limiting, deformation of a structural steel part.

### A3. MATERIAL

**1. Structural Steel.** Material conforming to one of the following standard specifications is approved for use under this Specification:

A36, A53 Grade B, A242, A441, A500, A501, A514, A529, A570 Grades 40, 45 and 50, A572, A588, A606, A607 and A618.

Certified mill test reports or certified reports of tests made by the fabricator or a testing laboratory in accordance with ASTM A6 or A568, as applicable, shall constitute sufficient evidence of conformity with one of the above ASTM standards. If requested, the fabricator shall provide an affidavit stating that the structural steel furnished meets the requirements of the grade specified.

Unidentified steel, if surface conditions are acceptable according to criteria contained in ASTM A6, may be used for unimportant members or details, where the precise physical properties and weldability of the steel would not affect the strength of the structure.

For A6 Group 4 and 5 rolled shapes to be used as members subject to primary tensile stresses due to tension or flexure, toughness need not be specified if splices are made by bolting. If such members are spliced using full penetration welds, the steel shall be specified in the contract document to be supplied with Charpy V-Notch testing in accordance with ASTM A6, Supplementary Requirement S5. The impact test shall meet a minimum average value of 20 ft-lbs. (27.1 N·m) absorbed energy at + 70°F. (21°C.).

The above supplementary toughness requirements shall also be considered for welded full-penetration joints other than splices in heavy rolled and built-up members subject to primary tensile stresses.

Additional requirements for joints in heavy rolled and built-up members are given in Sections J1.10, J1.11, J2.7, J2.8 and M2.2.

**2. Steel Castings and Forgings.** Cast steel shall conform to one of the following standard specifications:

A27 Grade 65-25 and A148 Grade 80-50.

Steel forgings shall conform to the following standard specification:

A668.

Certified test reports shall constitute sufficient evidence of conformity with the standards.

**3. Bolts.** Steel bolts shall conform to one of the following standard specifications:

A307, A325, A449, A490, A563 and F436.

A449 bolts may be used only in connections requiring bolt diameters greater than  $1\frac{1}{2}$  inches (38 mm) and shall not be used in slip-critical connections. A449 material is acceptable for high-strength anchor bolts and threaded rods of any diameter.

Manufacturer's certification shall constitute sufficient evidence of conformity with the standards.

**4. Anchor Bolts and Threaded Rods.** Anchor bolt and threaded rod steel shall conform to one of the following standard specifications:

A36, A354, A588, A687 and ANSI B18.1-72, Grade 2A tolerance.

Steel bolts conforming to other provisions of Section A3 may be used as anchor bolts.

Manufacturer's certification shall constitute sufficient evidence of conformity with the standards.

**5. Filler Metal and Flux for Welding.** Welding electrodes and fluxes shall conform to one of the following specifications of the American Welding Society.\*

A5.1, A5.5, A5.17, A5.18, A5.20, A5.23, A5.28 and A5.29.

Manufacturer's certification shall constitute sufficient evidence of conformity with the standards.

**6. Stud Shear Connectors.** Steel stud shear connectors shall conform to the requirements of approved national standards.

Manufacturer's certification shall constitute sufficient evidence of conformity with the code.

#### A4. LOADS AND LOAD COMBINATIONS

Modified per Part I.

The nominal loads shall be the minimum design loads required by the code and the load combinations shall be as specified in Section A4.1.

**1. Loads, Load Factors and Load Combinations.** The following nominal loads are to be considered:

$D$  = dead load due to the weight of the structural elements and the permanent features on the structure

$L$  = live load due to occupancy and moveable equipment

$L_r$  = roof live load

$W$  = wind load

---

\*Approval of these welding electrode specifications is given without regard to weld metal notch toughness requirements, which are generally not critical for building construction.

$S$  = snow load

$E$  = earthquake load

$R$  = load due to initial rainwater or ice exclusive of the ponding contribution

The required strength of the structure and its elements must be determined from the appropriate critical combination of factored loads. The most critical effect may occur when one or more loads are not acting. The following load combinations and the corresponding load factors shall be investigated:

$$1.4D \quad (A4-1)$$

$$1.2D + 1.6L + 0.5(L_r \text{ or } S \text{ or } R) \quad (A4-2)$$

$$1.2D + 1.6(L_r \text{ or } S \text{ or } R) + (0.5L \text{ or } 0.8W) \quad (A4-3)$$

$$1.2D + 1.3W + 0.5L + 0.5(L_r \text{ or } S \text{ or } R) \quad (A4-4)$$

$$1.2D + 1.5E + (0.5L \text{ or } 0.2S) \quad (A4-5)$$

$$0.9D - (1.3W \text{ or } 1.5E) \quad (A4-6)$$

**EXCEPTION:** The load factor on  $L$  in combinations A4-3, A4-4 and A4-5 shall equal 1.0 for garages, areas occupied as places of public assembly and all areas where the live load is greater than 100 psf (4.8 kN/m<sup>2</sup>).

**2. Impact.** For structures carrying live loads which induce impact, the assumed nominal live load shall be increased to provide for this impact in Formulas (A4- 2) and (A4-3).

If not otherwise specified, the increase shall be:

For supports of elevators and elevator machinery	100%
For supports of light machinery, shaft or motor driven, not less than	20%
For supports of reciprocating machinery or power driven units, not less than	50%
For hangers supporting floors and balconies	33%
For cab-operated traveling crane support girders and their connections	25%
For pendant-operated traveling crane support girders and their connections	10%

**3. Crane Runway Horizontal Forces.** The nominal lateral force on crane runways to provide for the effect of moving crane trolleys shall be a minimum of 20 percent of the sum of weights of the lifted load and of the crane trolley, but exclusive of other parts of the crane. The force shall be assumed to be applied at the top of the rails, acting in either direction normal to the runway rails, and shall be distributed with due regard for lateral stiffness of the structure supporting the rails.

The longitudinal force shall be a minimum of 10 percent of the maximum wheel loads of the crane applied at the top of the rail, unless otherwise specified.

## A5. DESIGN BASIS

**1. Required Strength at Factored Loads.** The required strength of structural members and connections shall be determined by structural analysis for the appropriate factored load combinations given in Section A4.

Design by either elastic or plastic analysis is permitted, except that plastic analysis is permitted only for steels with yield stress not exceeding 65 ksi (450 N/mm<sup>2</sup>) and is subject to provisions of Sections B5.2, C2, E1.2, F1.1, H1 and I1.

Except for hybrid girders and members of A514 steel, beams and girders (including members designed on the basis of composite action) which meet the requirements of the above, and are continuous over supports or are rigidly framed to columns by means of rivets, high-strength bolts, or welds, may be proportioned for <sup>9</sup>/<sub>10</sub> of the negative moments produced by gravity loading which are maximum at points of support, provided that, for such members, the maximum positive moment shall be increased by <sup>1</sup>/<sub>10</sub> of the average negative moments. This reduction shall not apply to mo-

ments produced by loading on cantilevers. If the negative moment is resisted by a column rigidly framed to the beam or girder, the  $1/10$  reduction may be used in proportioning the column for the combined axial and bending loading, provided that the stress,  $f_a$ , due to any concurrent axial load on the member, does not exceed  $0.15F_a$ .

**2. Limit States.** LRFD is a method of proportioning structures so that no applicable limit state shall be exceeded when the structure is subjected to all appropriate factored load combinations.

Strength limit states are related to safety and concern maximum load carrying capacity. Serviceability limit states are related to performance under normal service conditions. The term "resistance" includes both strength limit states and serviceability limit states.

**3. Design for Strength.** The design strength of each structural component or assemblage shall equal or exceed the required strength based on the factored nominal loads. The design strength  $\phi R_n$  is calculated for each applicable limit state as the nominal strength,  $R_n$ , multiplied by a resistance factor,  $\phi$ . The required strength is determined for each applicable load combination as stipulated in Section A4.

Nominal strength,  $R_n$ , and resistance factors,  $\phi$ , are given in the appropriate chapters. Additional strength considerations are given in Chapter K.

**4. Design for Serviceability and Other Considerations.** The overall structure and the individual members, connections and connectors should be checked for serviceability. Provisions for design for serviceability are given in Chapter L.

## A6. REFERENCED CODES AND STANDARDS

Modified per Part I.

American National Standards Institute

B18.1-72

A58.1-82

American Society for Testing and Materials

A6-84c

A27-84

A36-84a

A53-84a

A148-84

A242-84

A307-84

A325-84

A354-84b

A441-84

A449-84a

A490-84

A500-84

A501-84

A514-84a

A529-84

A563-84

A570-84a

A572-84

A588-84a

A606-84

A607-84a

A618-84

A668-83

A687-84

C33-85

C330-85

F436-84

American Welding Society

A5.1-81

A5.5-81

A5.17-80

A5.18-79

A5.20-79

A5.23-80

A5.28-79

A5.29-80

D1.1-85

International Conference of Building Officials

U.B.C. Chapter 22, Division IV

## A7. DESIGN DOCUMENTS

**1. Plans.** The design plans shall show a complete design with sizes, sections and relative locations of the various members. Floor levels, column centers and offsets shall be dimensioned. Drawings shall be drawn to a scale large enough to show the information clearly.

Design documents shall indicate the type or types of construction as defined in Section A2.2 and include the nominal loads and design strengths if necessary for preparation of shop drawings.

Where joints are to be assembled with high-strength bolts, the design documents shall indicate the connection type (slip-critical, tension or bearing).

Camber of trusses, beams and girders, if required, shall be called for in the design documents. The requirements for stiffeners and bracing shall be shown on the design documents.

**2. Standard Symbols and Nomenclature.** Welding and inspection symbols used on plans and shop drawings shall preferably be the American Welding Society symbols. Other adequate welding symbols may be used, provided a complete explanation thereof is shown in the design documents.

**3. Notation for Welding.** Notes shall be made in the design documents and on the shop drawings of those joints or groups of joints in which the welding sequence and technique of welding should be carefully controlled to minimize distortion.

Weld lengths called for in the design documents and on the shop drawings shall be the net effective lengths.

## CHAPTER B

### DESIGN REQUIREMENTS

This chapter contains provisions which are common to the Specification as a whole.

#### B1. GROSS AREA

The gross area  $A_g$  of a member at any point is the sum of the products of the thickness and the gross width of each element measured normal to the axis of the member. For angles, the gross width is the sum of the widths of the legs less the thickness.

Plate girders, coverplated beams and rolled or welded beams shall be proportioned on the basis of the gross section. No deduction shall be made for shop or field bolt holes in either flange, unless the reduction of the area of either flange by such holes calculated in accordance with the provisions of Section B2 exceeds 15 percent of the gross flange area, in which case the area in excess of 15 percent shall be deducted.

Hybrid girders may be proportioned on the basis of their gross section, provided that they are not required to resist an axial force greater than  $\phi_b$  times  $0.15 A_g F_{yf}$ . No limit is placed on the flexural stress in the web.

Flanges of welded plate girders may be varied in thickness or width by splicing plates or by using cover plates.

#### B2. NET AREA

The net area,  $A_n$ , of a member is the sum of the products of the thickness and the net width of each element computed as follows:

In computing net area for tension, the width of a bolt hole shall be taken as  $1/16$ -inch (2 mm) greater than the nominal dimension of the hole normal to the direction of applied stress. For shear, the width shall be taken as the nominal dimension of the hole.

For a chain of holes extending across a part in any diagonal or zigzag line, the net width of the part shall be obtained by deducting from the gross width the sum of the diameters or slot dimensions as provided in Section J3.7 of all holes in the chain, and adding, for each gage space in the chain, the quantity  $s^2/4g$ .

**WHERE:**

- $g$  = transverse center-to-center spacing (gage) between fastener gage lines, in. (mm)
- $s$  = longitudinal center-to-center spacing (pitch) of any two consecutive holes, in. (mm)

For angles, the gage for holes in opposite adjacent legs shall be the sum of the gages from the back of the angles less the thickness.

The critical net area,  $A_n$ , of the part is obtained from that chain which gives the least net width.

In determining the net area across plug or slot welds, the weld metal shall not be considered as adding to the net area.

**B3. EFFECTIVE NET AREA**

When the load is transmitted directly to each of the cross-sectional elements by connectors, the effective net area,  $A_e$ , is equal to the net area,  $A_n$ .

When the load is transmitted by bolts or rivets through some, but not all, of the cross-sectional elements of the member, the effective net area,  $A_e$ , shall be computed as:

$$A_e = U A_n \tag{B3-1}$$

**WHERE:**

- $A_n$  = net area of the member, in.<sup>2</sup> (mm<sup>2</sup>)
- $U$  = reduction coefficient

When the load is transmitted by welds through some, but not all, of the cross-sectional elements of the member, the effective net area  $A_e$  shall be computed as:

$$A_e = U A_g \tag{B3-2}$$

**WHERE:**

- $A_g$  = gross area of member, in.<sup>2</sup> (mm<sup>2</sup>)

Unless a larger coefficient can be justified by tests or other rational criteria, the following values of  $U$  shall be used:

- a. W, M or S shapes with flange widths not less than two thirds the depth, and structural tees cut from these shapes, provided the connection is to the flanges. Bolted or riveted connections shall have no fewer than three fasteners per line in the direction of stress . . . . .  $U = 0.90$
- b. W, M or S shapes not meeting the conditions of Subparagraph a, structural tees cut from these shapes and all other shapes, including built-up cross sections. Bolted or riveted connections shall have no fewer than three fasteners per line in the direction of stress . . . . .  $U = 0.85$
- c. All members with bolted or riveted connections having only two fasteners per line in the direction of stress . . . . .  $U = 0.75$

When load is transmitted by transverse welds to some, but not all, of the cross-sectional elements of W, M or S shapes and structural tees cut from these shapes,  $A_e$  shall be taken as the area of the directly connected elements.

When the load is transmitted to a plate by longitudinal welds along both edges at the end of the plate, the length of the welds shall not be less than the width of the plate. The effective net area,  $A_e$ , shall be computed as:

$$A_e = U A_g \tag{B3-2}$$

Unless a larger coefficient can be justified by tests or other rational criteria, the following values of  $U$  shall be used:

- a. When  $l > 2w$  . . . . .  $U = 1.0$
- b. When  $2w > l > 1.5w$  . . . . .  $U = 0.87$

c. When  $1.5w > lw$  .....  $U = 0.75$

**WHERE:**

$l$  = weld length, in. (mm)

$w$  = plate width (distance between welds), in. (mm)

**B4. STABILITY**

General stability shall be provided for the structure as a whole and for each compression element.

Consideration shall be given to significant load effects resulting from the deflected shape of the structure or of individual elements of the lateral-load-resisting system.

**B5. LOCAL BUCKLING**

**1. Classification of Steel Sections.** Steel sections are classified as compact, noncompact and slender element sections. For a section to qualify as compact, its flanges shall be continuously connected to the web or webs and the width-thickness ratios of its compression elements must not exceed the limiting width-thickness ratios  $\lambda_p$  from Table B5.1. If the width-thickness ratio of one or more compression elements exceeds  $\lambda_p$ , but does not exceed  $\lambda_r$ , the section is noncompact. If the width-thickness ratio exceeds  $\lambda_r$  from Table B5.1, the element is referred to as a slender compression element.

For unstiffened elements which are supported along only one edge, parallel to the direction of the compression force, the width shall be taken as follows:

- a. For flanges of I-shaped members and tees, the width  $b$  is half the full nominal width.
- b. For legs of angles and flanges of channels and tees, the width  $b$  is the full nominal dimension.
- c. For plates, the width  $b$  is the distance from the free edge to the first row of fasteners or line of welds.
- d. For stems of tees,  $d$  is taken as the full nominal depth.

For stiffened elements, i.e., supported along two edges parallel to the direction of the compression force, the width shall be taken as follows:

- a. For webs of rolled or formed sections,  $h$  is the clear distance between flanges less the fillet or corner radius at each flange;  $h_c$  is twice the distance from the neutral axis to the inside face of the compression flange less the fillet or corner radius.
- b. For webs of built-up sections,  $h$  is the distance between adjacent lines of fasteners or the clear distance between flanges when welds are used, and  $h_c$  is twice the distance from the neutral axis to the nearest line of fasteners at the compression flange or the inside face of the compression flange when welds are used.
- c. For flange or diaphragm plates in built-up sections, the width  $b$  is the distance between adjacent lines of fasteners or lines of welds.
- d. For flanges of rectangular hollow structural sections, the width  $b$  is the clear distance between webs less the inside corner radius on each side. If the corner radius is not known, the flat width may be taken as the total section width minus three times the thickness.

For tapered flanges of rolled sections, the thickness is the nominal value half-way between the free edge and the corresponding face of the web.

**TABLE B5.1**  
**Limiting Width-Thickness Ratios for Compression Elements**

Description of Element	Width-Thickness Ratio	Limiting Width-Thickness Ratios	
		$\lambda_p$	$\lambda_r$
Flanges of I-shaped rolled beams and channels in flexure	$b/t$	$65/\sqrt{F_y^c}$	$141/\sqrt{F_y - 10}$
Flanges of I-shaped hybrid or welded beams in flexure	$b/t$	$65/\sqrt{F_{yf}^c}$	$\frac{106}{\sqrt{F_{yw} - 16.5}}$
Flanges of I-shaped sections in pure compression, plates projecting from compression elements; outstanding legs of pairs of angles in continuous contact; flanges of channels in pure compression	$b/t$	NA	$95/\sqrt{F_y}$
Flanges of square and rectangular box and hollow structural sections of uniform thickness subject to bending or compression; flange cover plates and diaphragm plates between lines of fasteners or welds	$b/t$	$190/\sqrt{F_y}$	$238/\sqrt{F_y - F_r^e}$
Unsupported width of cover plates perforated with a succession of access holes <sup>b</sup>	$b/t$	NA	$317/\sqrt{F_y - F_r^e}$
Legs of single angle struts; legs of double angle struts with separators; unstiffened elements, i.e., supported along one edge	$b/t$	NA	$76/\sqrt{F_y}$
Stems of tees	$d/t$	NA	$127/\sqrt{F_y}$
All other uniformly compressed stiffened elements, i.e., supported along two edges	$b/t$ $h_c/t_w$	NA	$253/\sqrt{F_y}$
Webs in flexural compression <sup>a</sup>	$h_c/t_w$	$640/\sqrt{F_y^c}$	$970/\sqrt{F_y}$
Webs in combined flexural and axial compression	$h_c/t_w$	for $P_u/\phi_b P_y \leq 0.125$ $\frac{640}{\sqrt{F_y}} \left( 1 - \frac{2.75 P_u}{\phi_b P_y} \right)^c$ for $P_u/\phi_b P_y > 0.125$ $\frac{191}{\sqrt{F_y}} \left( 2.33 - \frac{P_u}{\phi_b P_y} \right) \geq \frac{253^c}{\sqrt{F_y}}$	$970/\sqrt{F_y}$
Circular hollow sections In axial compression In flexure	$D/t$	$2,070/F_y^d$ $2,070/F_y^d$	$3,300/F_y$ $8,970/F_y$

<sup>a</sup>For hybrid beams, use the yield strength of the flange,  $F_{yf}$ , instead of  $F_y$ .  
<sup>b</sup>Assumes net area of plate at widest hole.  
<sup>c</sup>Assumes an inelastic rotation capacity of 3. For structures in zones of high seismicity, a greater rotation capacity may be required. See Table C-B5.1.  
<sup>d</sup>For plastic design use  $1,300/F_y$ .  
<sup>e</sup> $F_r$  = compressive residual stress in flange  
= 10 ksi for rolled shapes  
= 16.5 ksi for welded shapes.

**NOTE:** See next page for metric conversions.

TABLE B5.1  
Limiting Width-Thickness Ratios for Compression Elements

Description of Element	Width-Thickness Ratio	Limiting Width-Thickness Ratios	
		$\lambda_p$	$\lambda_r$
Flanges of I-shaped rolled beams and channels in flexure	$b/t$	$0.38 \sqrt{\frac{E^c}{F_y}}$	$0.83 / \sqrt{\frac{E}{F_y - F_r}}$
Flanges of I-shaped hybrid or welded beams in flexure	$b/t$	$0.38 \sqrt{\frac{E^c}{F_{yf}}}$	$0.62 \sqrt{\frac{E^c}{F_y - F_r}}$
Flanges of I-shaped sections in pure compression, plates projecting from compression elements; outstanding legs of pairs of angles in continuous contact; flanges of channels in pure compression	$b/t$	NA	$0.56 \sqrt{\frac{E}{F_y}}$
Flanges of square and rectangular box and hollow structural sections of uniform thickness subject to bending or compression; flange cover plates and diaphragm plates between lines of fasteners or welds	$b/t$	$1.12 \sqrt{\frac{E}{F_y}}$	$1.40 \sqrt{\frac{E^c}{F_y - F_r}}$
Unsupported width of cover plates perforated with a succession of access holes <sup>b</sup>	$b/t$	NA	$1.86 \sqrt{\frac{E^c}{F_y - F_r}}$
Legs of single angle struts; legs of double angle struts with separators; unstiffened elements, i.e., supported along one edge	$b/t$	NA	$0.45 \sqrt{\frac{E}{F_y}}$
Stems of tees	$d/t$	NA	$0.75 \sqrt{\frac{E}{F_y}}$
All other uniformly compressed stiffened elements, i.e., supported along two edges	$b/t$ $h_c/t_w$	NA	$1.49 \sqrt{\frac{E}{F_y}}$
Webs in flexural compression <sup>a</sup>	$h_c/t_w$	$3.76 \sqrt{\frac{E^c}{F_y}}$	$5.70 \sqrt{\frac{E}{F_y}}$
Webs in combined flexural and axial compression	$h_c/t_w$	for $P_u/\phi_b P_y \leq 0.125$ $3.76 \sqrt{\frac{E}{F_y}} \left(1 - \frac{2.75 P_u}{\phi_b P_y}\right)^c$	$5.70 \sqrt{\frac{E}{F_y}}$
		for $P_u/\phi_b P_y > 0.125$ $1.12 \sqrt{\frac{E}{F_y}} \left(2.33 - \frac{P_u}{\phi_b P_y}\right) \leq 1.49 \sqrt{\frac{E^c}{F_y}}$	
Circular hollow sections In axial compression In flexure	$D/t$	$0.07(E/F_y)^d$ $0.07(E/F_y)^d$	$0.11 (E/F_y)$ $0.31 (E/F_y)$

<sup>a</sup>For hybrid beams, use the yield strength of the flange,  $F_{yf}$ , instead of  $F_y$ .  
<sup>b</sup>Assumes net area of plate at widest hole.  
<sup>c</sup>Assumes an inelastic rotation capacity of 3. For structures in zones of high seismicity, a greater rotation capacity may be required. See Table C-B5.1.  
<sup>d</sup>For plastic design use  $0.045 (E/F_y)$ .  
<sup>e</sup> $F_r$  = compressive residual stress in flange  
= 70 N/mm<sup>2</sup> for rolled shapes  
= 115 N/mm<sup>2</sup> for welded shapes.

**2. Sections for Plastic Analysis.** Plastic analysis is permitted when flanges subject to compression involving hinge rotation and all webs have a width-thickness ratio less than or equal to the limiting  $\lambda_p$  from Table B5.1. For circular hollow sections, see Footnote d of Table B5.1.

Plastic analysis shall be subject to the limitations as outlined in Section A5.1.

**3. Slender Compression Elements.** For the flexural design of I-shaped sections, channels and rectangular or circular sections with slender compression elements, see Appendix F1.7. For other shapes in flexure or members in axial compression that have slender compression elements, see Appendix B5.3. For plate girders with  $h_c/t_w > 970/\sqrt{F_{yf}}$  (For SI:  $5.70\sqrt{E/F_{yf}}$ ), see Appendix G.

## B6. BRACING AT SUPPORTS

At points of support for beams, girders and trusses, restraint against rotation about their longitudinal axis shall be provided unless restraint against rotation is otherwise assured.

## B7. LIMITING SLENDERNESS RATIOS

For members whose design is based on compressive force, the slenderness ratio  $Kl/r$  preferably should not exceed 200.

For members whose design is based on tensile force, the slenderness ratio  $L/r$  preferably should not exceed 300. The above limitation does not apply to rods in tension. Such tension members may be subject to compressive force not exceeding 50 percent of the design compressive strength when such compressive force is due to wind or earthquake.

# CHAPTER C

## FRAMES AND OTHER STRUCTURES

This chapter specifies general requirements to assure stability of the structure as a whole.

### C1. SECOND ORDER EFFECTS

Second order ( $P\Delta$ ) effects shall be considered in the design of frames.

### C2. FRAME STABILITY

**1. Braced Frames.** In trusses and frames where lateral stability is provided by diagonal bracing, shear walls or equivalent means, the effective length factor,  $K$ , for compression members shall be taken as unity, unless structural analysis shows that a smaller value may be used.

The vertical bracing system for a braced multistory frame shall be adequate, as determined by structural analysis, to prevent buckling of the structure and maintain the lateral stability of the structure, including the overturning effects of drift, under the factored loads given in Section A4.

The vertical bracing system for a multistory frame may be considered to function together with in-plane shear-resisting exterior and interior walls, floor slabs and roof decks, which are properly secured to the structural frames. The columns, girders, beams and diagonal members, when used as the vertical bracing system, may be considered to comprise a vertical cantilever, simply connected truss in the analyses for frame buckling and lateral instability. Axial deformation of all members in the vertical bracing system shall be included in the lateral stability analysis.

Girders and beams included in the vertical bracing system of a braced multistory frame shall be proportioned for axial force and moment caused by concurrent factored horizontal and gravity loads.

**2. Unbraced Frames.** In frames where lateral stability depends upon the bending stiffness of rigidly connected beams and columns, the effective length factor,  $K$ , of compression members shall be determined by structural analysis and shall not be less than unity.

Analysis of the required strength of unbraced multistory frames shall include the effects of frame instability and column axial deformation under the factored loads given in Section A4.

In plastic design, the axial force in the columns caused by factored gravity plus factored horizontal loads shall not exceed  $0.75 A_g F_y$ .

## CHAPTER D

### TENSION MEMBERS

This chapter applies to prismatic members subject to axial tension caused by static forces acting through the centroidal axis. For members subject to combined axial tension and flexure, see Section H1. For members subject to fatigue, see Section K4. For tapered members, see Appendix F4. For threaded rods, see Section J3.

#### D1. DESIGN TENSILE STRENGTH

The design strength of tension members  $\phi_t P_n$  shall be the lower value obtained according to the limit states of yielding in the gross section and fracture in the net section.

a. For yielding in the gross section:

$$\begin{aligned} \phi_t &= 0.90 \\ P_n &= F_y A_g \end{aligned} \tag{D1-1}$$

b. For fracture in the net section:

$$\begin{aligned} \phi_t &= 0.75 \\ P_n &= F_u A_e \end{aligned} \tag{D1-2}$$

#### WHERE:

- $A_e$  = effective net area, in.<sup>2</sup> (mm<sup>2</sup>)
- $A_g$  = gross area of member, in.<sup>2</sup> (mm<sup>2</sup>)
- $F_y$  = specified minimum yield stress, ksi (N/mm<sup>2</sup>)
- $F_u$  = specified minimum tensile strength, ksi (N/mm<sup>2</sup>)
- $P_n$  = nominal axial strength, kips (N)

When members without holes are fully connected by welds, the effective net section used in Formula (D1-2) shall be computed using the smaller of the gross area of the member or the effective area of the welds as defined in Section J2. When holes are present in a welded member between end connections, or at the welded connection in the case of plug or slot welds, the net section through the holes shall be used in Formula (D1-2).

#### D2. BUILT-UP MEMBERS

The longitudinal spacing of connectors between elements in continuous contact consisting of a plate and a shape or two plates shall not exceed:

24 times the thickness of the thinner plate or 12 inches (305 mm) for painted members or unpainted members not subject to corrosion.

14 times the thickness of the thinner plate or 7 inches (180 mm) for unpainted members of weathering steel subject to atmospheric corrosion.

The longitudinal spacing of connectors between components should preferably limit the slenderness ratio in any component between the connectors to 300 or less.

Either perforated cover plates or tie plates without lacing may be used on the open sides of built-up tension members. Tie plates shall have a length not less than two thirds the distance between the lines of welds or fasteners connecting them to the components of the member. The thickness of such tie plates shall not be less than  $1/50$  of the distance between these lines. The longitudinal spacing of intermittent welds or fasteners at tie plates shall not exceed 6 inches (152 mm). The spacing of tie plates shall be such that the slenderness ratio of any component in the length between tie plates should preferably not exceed 300.

### D3. EYEBARS AND PIN-CONNECTED MEMBERS

The design strength of eyebars shall be determined in accordance with Section D1 with  $A_g$  taken as the cross-sectional area of the body.

Eyebars shall be of uniform thickness, without reinforcement at the pin holes, and have circular heads whose periphery is concentric with the pin hole.

The radius of transition between the circular head and the eyebar body shall not be less than the head diameter.

The width of the body of the eyebars shall not exceed eight times its thickness.

The thickness can be less than  $1/2$  inch (13 mm) only if external nuts are provided to tighten pin plates and filler plates into snug contact. The width  $b$  from the hole edge to the plate edge perpendicular to the direction of applied load shall be greater than two thirds and, for the purpose of calculation, not more than  $3/4$  times the eyebar body width.

The pin diameter shall not be less than  $7/8$  times the eyebar body width.

The pin-hole diameter shall not be more than  $1/32$ -inch (1.0 mm) greater than the pin diameter.

For steels having a yield stress greater than 70 ksi (480 N/mm<sup>2</sup>), the hole diameter shall not exceed five times the plate thickness and the width of the eyebar body shall be reduced accordingly. In pin-connected members, the pin hole shall be located midway between the edges of the member in the direction normal to the applied force. For pin-connected members in which the pin is expected to provide for relative movement between connected parts while under full load, the diameter of pin hole shall not be more than  $1/32$  inch (1.0 mm) greater than the diameter of the pin. The width of the plate beyond the pin hole shall be not less than the effective width on either side of the pin hole.

In pin-connected plates other than eyebars, the design strength shall be determined according to Formula (D1-2) and the bearing strength of the projected area of pin shall be determined according to Section J8. The minimum net area beyond the bearing end of the pin hole, parallel to the axis of the member, shall not be less than two thirds of the net area required for strength across the pin hole.

The design strength of a pin-connected member  $\phi_t P_n$  shall be the lowest value of the following limit states:

- a. Tension on the net effective area:

$$\phi_t = 0.75$$

$$P_n = 2tb_{eff}F_u \quad (D3-1)$$

- b. Shear on the effective area:

$$\phi_{sf} = 0.75$$

$$P_n = A_{sf}F_y \quad (D3-2)$$

- c. Bearing on the projected area of the pin:

$$\phi = 1.0$$

$$P_n = A_{pb}F_y \quad (D3-3)$$

#### WHERE:

- $a$  = shortest distance from edge of the pin hole to the edge of the member measured parallel to the direction of the force, in. (mm)

$A_{pb}$  = projected bearing area, in.<sup>2</sup> (mm<sup>2</sup>)

$A_{sf}$  =  $2t(a + d/2)$ , in.<sup>2</sup> (mm<sup>2</sup>)

$b_{eff}$  =  $2t + 0.63$  (For **SI**:  $2t + 16$ ), but not more than the actual distance from the edge of the hole to the edge of the part measured in the direction normal to the applied force, in. (mm)

$d$  = pin diameter, in. (mm)

$t$  = thickness of plate, in. (mm)

The corners beyond the pin hole may be cut 45 degrees to the axis of the member, provided the net area beyond the pin hole, on a plane perpendicular to the cut, is not less than that required beyond the pin hole parallel to the axis of the member.

Thickness limitations on both eyebars and pin-connected plates may be waived whenever external nuts are provided so as to tighten pin plates and filler plates into snug contact. When the plates are thus contained, the bearing strength shall be determined according to Section J8.

## CHAPTER E

### COLUMNS AND OTHER COMPRESSION MEMBERS

This section applies to prismatic members subject to axial compression through the centroidal axis. For members subject to combined axial compression and flexure, see Chapter H. For tapered members, see Appendix F4.

#### E1. EFFECTIVE LENGTH AND SLENDERNESS LIMITATIONS

**1. Effective Length.** The effective length factor,  $K$ , shall be determined in accordance with Section C2.

**2. Plastic Analysis.** Plastic analysis, as limited in Section A5.1, is permitted if the column slenderness parameter  $\lambda_c$  defined by Formula (E2-4) does not exceed 1.5K.

#### E2. DESIGN COMPRESSIVE STRENGTH

The design strength of compression members whose elements have width-thickness ratios less than  $\lambda_r$  of Section B5.1 is  $\phi_c P_n$ .

$$\phi_c = 0.85$$

$$P_n = A_g F_{cr} \quad (\text{E2-1})$$

for  $\lambda_c \leq 1.5$

$$F_{cr} = (0.658^{\lambda_c^2}) F_y \quad (\text{E2-2})$$

for  $\lambda_c \leq 1.5$

$$F_{cr} = \left[ \frac{0.877}{\lambda_c^2} \right] F_y \quad (\text{E2-3})$$

where

$$\lambda_c = \frac{Kl}{r\pi} \sqrt{\frac{F_y}{E}} \quad (\text{E2-4})$$

$A_g$  = gross area of member, in.<sup>2</sup> (mm<sup>2</sup>)

$E$  = modulus of elasticity, ksi (N/mm<sup>2</sup>)

$F_y$  = specified yield stress, ksi (N/mm<sup>2</sup>)

- $K$  = effective length factor  
 $l$  = unbraced length of member, in. (mm)  
 $r$  = governing radius of gyration about plane of buckling, in. (mm)

For members whose elements do not meet the requirements of Section B5.1, see Appendix B5.3.

### E3. FLEXURAL-TORSIONAL BUCKLING

Singly symmetric and unsymmetric columns, such as angle or tee-shaped columns, and doubly symmetric columns such as cruciform or built-up columns with very thin walls, may require consideration of the limit states of flexural-torsional and torsional buckling. See Appendix E3 for the determination of design strength for these limit states.

### E4. BUILT-UP MEMBERS

At the ends of built-up compression members bearing on base plates or milled surfaces, all components in contact with one another shall be connected by a weld having a length not less than the maximum width of the member or by bolts spaced longitudinally not more than four diameters apart for a distance equal to one and one-half times the maximum width of the member.

Along the length of built-up compression members between the end connections required above, longitudinal spacing for intermittent welds, bolts or rivets shall be adequate to provide for the transfer of calculated stress. However, where a component of a built-up compression member consists of an outside plate, except as provided in the next sentence, the maximum spacing shall not exceed the thickness of the thinner outside plate times  $127/\sqrt{F_y}$  (For SI:  $0.75 \sqrt{E/F_y}$ ) or 12 inches (305 mm), when intermittent welds are provided along the edges of the components or when fasteners are provided on all gage lines at each section. When fasteners are staggered, the maximum spacing on each gage line shall not exceed the thickness of the thinner outside plate times  $190/\sqrt{F_y}$  (For SI:  $1.12 \sqrt{E/F_y}$ ) or 18 inches (457 mm).

For unpainted built-up members made of weathering steel which will be exposed to atmospheric corrosion, the fasteners connecting a plate and a shape or two-plate components in contact with one another shall not exceed 14 times the thickness of the thinnest part or 7 inches (180 mm), and the maximum edge distance shall not exceed eight times the thickness of the thinnest part, or 5 inches (127 mm).

Compression members composed of two or more shapes shall be connected to one another at intervals such that the slenderness ratio  $L/r$  of either shape, between the fasteners, does not exceed the governing slenderness ratio of the built-up member. The least radius of gyration,  $r$ , shall be used in computing the slenderness ratio of each component part.

The design strength of built-up members composed of two or more shapes shall be determined in accordance with Section E2 or Appendix E3 subject to the following modification. If the buckling mode involves relative deformation that produces shear forces in the connectors between individual shapes,  $Kl/r$  is replaced by  $(Kl/r)_m$  determined as follows:

- a. for snug-tight bolted connectors:

$$\left(\frac{Kl}{r}\right)_m = \sqrt{\left(\frac{Kl}{r}\right)_o^2 + \left(\frac{a}{r_i}\right)^2} \quad (E4-1)$$

- b. for welded connectors and for fully tightened bolted connectors as required for slip-critical joints:

$$\text{with } \frac{a}{r_i} > 50$$

$$\left(\frac{Kl}{r}\right)_m = \sqrt{\left(\frac{Kl}{r}\right)_o^2 + \left(\frac{a}{r_i} - 50\right)^2} \quad (\text{E4-2})$$

with  $\frac{a}{r_i} \leq 50$

$$\left(\frac{Kl}{r}\right)_m = \left(\frac{Kl}{r}\right)_o \quad (\text{E4-3})$$

where

$a$  = distance between connectors

$\frac{a}{r_i}$  = largest column slenderness of individual components

$\left(\frac{Kl}{r}\right)_o$  = column slenderness of built-up member acting as a unit

$\left(\frac{Kl}{r}\right)_m$  = modified column slenderness of built-up member

$r_i$  = minimum radius of gyration of individual component

Open sides of compression members built up from plates or shapes shall be provided with continuous cover plates perforated with a succession of access holes. The unsupported width of such plates at access holes, as defined in Section B5.1, is assumed to contribute to the design strength, provided that:

- a. The width-thickness ratio conforms to the limitations of Section B5.1.
- b. The ratio of length (in direction of stress) to width of hole shall not exceed two.
- c. The clear distance between holes in the direction of stress shall be not less than the transverse distance between nearest lines of connecting fasteners or welds.
4. The periphery of the holes at all points shall have a minimum radius of 1<sup>1</sup>/<sub>2</sub> inches (38 mm).

The function of perforated cover plates may be performed by lacing with tie plates at each end and at intermediate points if the lacing is interrupted. Tie plates shall be as near the ends as practicable. In main members providing design strength, the end tie plates shall have a length of not less than the distance between the lines of fasteners or welds connecting them to the components of the member. Intermediate tie plates shall have a length not less than <sup>1</sup>/<sub>2</sub> of this distance. The thickness of tie plates shall not be less than <sup>1</sup>/<sub>50</sub> of the distance between lines of welds or fasteners connecting them to the segments of the members. In welded construction, the welding on each line connecting a tie plate shall aggregate not less than <sup>1</sup>/<sub>3</sub> the length of the plate. In bolted and riveted construction, the spacing in the direction of stress in tie plates shall not be more than six diameters and the tie plates shall be connected to each segment by at least three fasteners.

Lacing, including flat bars, angles, channels or other shapes employed as lacing, shall be so spaced that the  $L/r$  ratio of the flange included between their connections shall not exceed the governing slenderness ratio for the member as a whole. Lacing shall be proportioned to provide a shearing strength normal to the axis of the member equal to 2 percent of the compressive design strength of the member. The  $L/r$  ratio for lacing bars arranged in single systems shall not exceed 140. For double lacing this ratio shall not exceed 200. Double lacing bars shall be joined at their intersections. For lacing bars in compression,  $L$  may be taken as the unsupported length of the lacing bar between welds or fasteners connecting it to the components of the built-up member for single lacing, and 70 percent of that distance for double lacing. The inclination of lacing bars to the axis of the member should preferably be not less than 60° for single lacing and 45° for double lacing. When the distance between the lines of welds or fasteners in the flanges is more than 15 inches, the lacing shall be double or be made of angles.

## E5. PIN-CONNECTED COMPRESSION MEMBERS

Pin-connections of pin-connected compression members shall conform to the requirements of Section D3 except Formulas (D1-1) and (D3-2) do not apply.

## CHAPTER F

### BEAMS AND OTHER FLEXURAL MEMBERS

This section applies to singly or doubly symmetric beams including hybrid beams and girders loaded in the plane of symmetry. It also applies to channels loaded in a plane passing through the shear center parallel to the web or restrained against twisting at load points and points of support. For design flexural strength for members not covered in Section F1, see Appendix F1.7. For members subject to combined flexural and axial force, see Section H1. For unsymmetric beams and beams subject to torsion combined with flexure, see Section H2.

### F1. DESIGN FOR FLEXURE

**1. Unbraced Length for Plastic Analysis.** Plastic analysis, as limited in Section A5, shall be permitted when the laterally unbraced length,  $L_b$ , of the compression flange at plastic hinge locations associated with the failure mechanism, for a compact section bent about the major axis, does not exceed  $L_{pd}$ , determined as follows:

- a. For doubly symmetric and singly symmetric I-shaped members with the compression flange larger than the tension flange (including hybrid members) loaded in the plane of the web.

$$L_{pd} = \frac{3,600 + 2,200(M_1/M_p)}{F_y} r_y \quad (\text{F1-1})$$

For SI:

$$L_{pd} = \left[ 0.12 + 0.076 \left( \frac{M_1}{M_p} \right) \right] \left[ \frac{E}{F_y} \right] r_y$$

**WHERE:**

- $F_y$  = specified minimum yield stress of the compression flange, ksi (N/mm<sup>2</sup>)  
 $M_1$  = smaller moment at end of unbraced length of beam, kip-in. (N·mm)  
 $M_p$  = plastic moment (=  $F_y Z$  for homogeneous sections; computed from fully plastic stress distribution for hybrids), kip-in. (N·mm)  
 $r_y$  = radius of gyration about minor axis, in. (mm)

( $M_1/M_p$ ) is positive when moments cause reverse curvature

- b. For solid rectangular bars and symmetric box beams

$$L_{pd} = \frac{5,000 + 3,000(M_1/M_p)}{F_y} r_y \geq 3,000 r_y / F_y \quad (\text{F1-2})$$

For SI:

$$L_{pd} = \left[ 0.17 + 0.10 \left( \frac{M_1}{M_2} \right) \right] \left[ \frac{E}{F_y} \right] r_y \geq 0.10 \frac{E}{F_y} r_y$$

There is no limit on  $L_b$  for members with circular or square cross sections or for any beam bent about its minor axis.

In the region of the last hinge to form, and in regions not adjacent to a plastic hinge, the flexural design strength shall be determined in accordance with Section F1.2.

**2. Flexural Design Strength.** The flexural design strength, determined by the limit state of lateral-torsional buckling, is  $\phi_b M_n$ , where the nominal strength,  $M_n$ , shall be determined in accordance with the following sections, and  $\phi_b = 0.90$ .

**3. Compact Section Members with  $L_b \leq L_r$ .** For laterally unsupported compact section members bent about the major axis:

$$M_n = C_b \left[ M_p - (M_p - M_r) \left( \frac{L_b - L_p}{L_r - L_p} \right) \right] \leq M_p \quad (\text{F1-3})$$

**WHERE:**

$C_b = 1.75 + 1.05(M_1/M_2) + 0.3(M_1/M_2)^2 \leq 2.3$  where  $M_1$  is the smaller end moment in the unbraced segment of the beam;  $M_1/M_2$  is positive when the moments cause reverse curvature and negative when bent in single curvature.

$C_b = 1.0$  for unbraced cantilevers and for members where the moment within a significant portion of the unbraced segment is greater than or equal to the larger of the segment end moments. For the use of larger  $C_b$  values, recognized design procedures shall be used.

$L_b =$  distance between points braced against lateral displacement of the compression flange, or between points braced to prevent twist of the cross section.

For I-shaped members including hybrid sections and channels bent about their major axis:

$$L_p = \frac{300r_y}{\sqrt{F_{yf}}} \quad (\text{F1-4})$$

For SI: 
$$L_p = 1.76r_y \sqrt{\frac{E}{F_{yf}}}$$

For solid rectangular bars and box beams:

$$L_p = \frac{3,750r_y}{M_p} \sqrt{JA} \quad (\text{F1-5})$$

For SI: 
$$L_p = \frac{0.13r_y E}{M_p} \sqrt{JA}$$

**WHERE:**

$A =$  cross-sectional area, in.<sup>2</sup> (mm<sup>2</sup>)

$J =$  torsional constant, in.<sup>4</sup> (mm<sup>4</sup>)

The limiting laterally unbraced length,  $L_r$ , and the corresponding buckling moment  $M_r$  shall be determined as follows:

- a. For I-shaped members, doubly symmetric and singly symmetric with the compression flange larger than or equal to the tension flange, and channels loaded in the plane of the web:

$$L_r = \frac{r_y X_1}{(F_{yw} - F_r)} \sqrt{1 + \sqrt{1 + X_2(F_{yw} - F_r)^2}} \quad (\text{F1-6})$$

$$M_r = (F_{yw} - F_r)S_x \quad (\text{F1-7})$$

**WHERE:**

$$X_1 = \frac{\pi}{S_x} \sqrt{\frac{EGJA}{2}} \quad (\text{F1-8})$$

$$X_2 = 4 \frac{C_w}{I_y} \left( \frac{S_x}{GJ} \right)^2 \quad (\text{F1-9})$$

- $C_w$  = warping constant, in.<sup>6</sup> (mm<sup>6</sup>)  
 $E$  = modulus of elasticity of steel [29,000 ksi (200 000 N/mm<sup>2</sup>)]  
 $F_r$  = compressive residual stress in flange; 10 ksi (70 N/mm<sup>2</sup>) for rolled shapes, 16.5 ksi (115 N/mm<sup>2</sup>) for welded shapes  
 $F_{yw}$  = yield stress of web, ksi (N/mm<sup>2</sup>)  
 $G$  = shear modulus of elasticity of steel [11,200 ksi (77 000 N/mm<sup>2</sup>)]  
 $I_y$  = moment of inertia about y-axis, in.<sup>4</sup> (mm<sup>4</sup>)  
 $S_x$  = section modulus about major axis, in.<sup>3</sup> (mm<sup>3</sup>)  
 b. For symmetric box section bent about the major axis and loaded in the plane of symmetry,  $M_r$  and  $L_r$  shall be determined from Formulas F1-7 and F1-10, respectively.  
 c. For solid rectangular bars bent about the major axis:

$$L_r = \frac{57,000 r_y \sqrt{JA}}{M_r} \quad (\text{F1-10})$$

For SI:

$$L_r = \frac{2 r_y E \sqrt{JA}}{M_r}$$

$$M_r = F_y S_x \quad (\text{F1-11})$$

**4. Compact Section Members with  $L_b > L_r$ .** For laterally unsupported members with compact section members bent about the major axis:

$$M_n = M_{cr} \leq C_b M_r \quad (\text{F1-12})$$

where  $M_{cr}$  is the critical elastic moment, determined as follows:

- a. For I-shaped members, doubly symmetric and singly symmetric with compression flange larger than the tension flange (including hybrid members) and channels loaded in the plane of the web:

$$M_{cr} = C_b \frac{\pi}{L_b} \sqrt{EI_y GJ + \left(\frac{\pi E}{L_b}\right)^2 I_y C_w} \quad (\text{F1-13})$$

$$= \frac{C_b S_x X_1 \sqrt{2}}{L_b/r_y} \sqrt{1 + \frac{X_1^2 X_2}{2(L_b/r_y)^2}}$$

- b. For solid rectangular bars and symmetric box sections:

$$M_{cr} = \frac{57,000 C_b \sqrt{JA}}{L_b/r_y} \quad (\text{F1-14})$$

For SI:

$$M_{cr} = \frac{2 C_b E \sqrt{JA}}{L_b/r_y}$$

**5. Tees and Double-angle Beams.** The nominal strength of tees and double-angle beams loaded in the plane of symmetry, with flange and web slenderness ratios less than the corresponding values of

$\lambda_r$  in Table B5.1.

$$M_n = M_{cr} = \frac{C_b \pi \sqrt{EI_y GJ}}{L_b} [B + \sqrt{1 + B^2}] \leq M_y \quad (\text{F1-15})$$

$$B = \pm 2.3 (d/L_b) \sqrt{I_y/J} \quad (\text{F1-16})$$

The plus sign for  $B$  applies when the stem is in tension and the minus sign applies when the stem is in compression.

**6. Noncompact Plate Girders.** The nominal strength of a doubly symmetric, single-web plate girder, including hybrid sections, shall be calculated by the provisions of Appendix F1.7 if  $h_c/t_w \leq 970/\sqrt{F_{yf}}$  (For SI:  $5.70\sqrt{E/F_{yf}}$ ) or by the provisions of Appendix G if  $h_c/t_w > 970/\sqrt{F_{yf}}$  (For SI:  $5.70\sqrt{E/F_{yf}}$ ).

**7. Nominal Flexural Strength of Other Sections.** There is no lateral-torsional buckling limit state for circular or square shapes or for any shape bent about its minor axis.

For the nominal strength  $M_n$  of other cross section types, including noncompact sections or sections with slender elements, see Appendix F1.7. See Appendix G for design of plate girders with slender webs.

## F2. DESIGN FOR SHEAR

This section applies to the web (or webs in the case of multiple web members) of singly or doubly symmetric beams, including hybrid beams, subject to shear in the plane of symmetry, and channels subject to shear in the web. Where failure might occur by shear along a plane through fasteners, refer to Section J4. For members subjected to high shear from concentrated loads, see Section K1.7.

**1. Web Area Determination.** The web area,  $A_w$ , shall be taken as the overall depth,  $d$ , times the web thickness,  $t_w$ .

**2. Design Shear Strength.** The design shear strength of webs is  $\phi_v V_n$  where  $\phi_v = 0.90$  and the nominal shear strength,  $V_n$ , determined as follows:

$$\text{For } \frac{h}{t_w} \leq 187 \sqrt{k/F_{yw}} \quad (\text{For SI: } \frac{h}{t_w} \leq 1.10 \sqrt{kE/F_{yw}}) \\ V_n = 0.6 F_{yw} A_w \quad (\text{F2-1})$$

$$\text{for } 187 \sqrt{k/F_{yw}} < \frac{h}{t_w} \leq 234 \sqrt{k/F_{yw}} \quad (\text{For SI: } 1.10 \sqrt{kE/F_{yw}} \leq \frac{h}{t_w} \leq 1.37 \sqrt{kE/F_{yw}}) \\ V_n = 0.6 F_{yw} A_w \frac{187 \sqrt{k/F_{yw}}}{h/t_w} \quad (\text{F2-2})$$

$$\text{For SI:} \quad V_n = 0.6 F_{yw} A_w \frac{1.10 \sqrt{kE/F_{yw}}}{h/t_w}$$

$$\text{for } \frac{h}{t_w} > 234 \sqrt{k/F_{yw}} \quad (\text{For SI: } \frac{h}{t_w} > 1.37 \sqrt{kE/F_{yw}}) \\ V_n = A_w \frac{26,400k}{(h/t_w)^2} \quad (\text{F2-3})$$

$$\text{For SI:} \quad V_n = A_w \frac{0.91 Ek}{(h/t_w)^2}$$

The web plate buckling coefficient,  $k$ , is given by

$$k = 5 + \frac{5}{(a/h)^2} \quad (\text{F2-4})$$

Except that  $k$  shall be taken as 5 if  $a/h$  exceeds 3.0 or  $[260/(h/t_w)]^2$ . When stiffeners are not required,  $k = 5$ . In unstiffened girders,  $h/t$  shall not exceed 260.

Maximum  $(h/t_w)$  limits are given in Appendix G1.

An alternative design method for plate girders utilizing tension field action is given in Appendix G.

### F3. TRANSVERSE STIFFENERS

Transverse stiffeners are not required when  $h/t_w \leq 418 \sqrt{F_{yw}}$  (For SI:  $h/t_w \leq 2.45 \sqrt{E/F_{yw}}$ ), or when the required shear,  $V_u$ , as determined by structural analysis for the factored loads, is less than or equal to  $\phi_v V_n$  for  $k = 5$  given in Section F2. Transverse stiffeners used to develop the web design shear strength as provided in Section F2 shall have a moment of inertia about an axis in the web center for stiffener pairs or about the face in contact with the web plate for single stiffeners, which shall not be less than  $at_w^3 j$ , where

$$j = \frac{2.5}{(a/h)^2} - 2 \geq 0.5 \quad (\text{F3-1})$$

Intermediate stiffeners may be stopped short of the tension flange, provided bearing is not needed to transmit a concentrated load or reaction. The weld by which intermediate stiffeners are attached to the web shall be terminated not less than four times or more than six times the web thickness from the near toe of the web-to-flange weld. When single stiffeners are used, they shall be attached to the compression flange, if it consists of a rectangular plate, to resist any uplift tendency due to torsion in the plate. When lateral bracing is attached to a stiffener or a pair of stiffeners, these in turn shall be connected to the compression flange to transmit 1 percent of the total flange stress, unless the flange is composed only of angles.

Bolts connecting stiffeners to the girder web shall be spaced not more than 12 inches (305 mm) on center. If intermittent fillet welds are used, the clear distance between welds shall not be more than 16 times the web thickness or more than 10 inches (254 mm).

### F4. WEB-TAPERED MEMBERS

See Appendix F4.

## CHAPTER G

### G. PLATE GIRDERS

Plate girders shall be distinguished from beams on the basis of the web slenderness ratio,  $h_c/t_w$ . When this value is greater than  $970/\sqrt{F_{yf}}$  (For SI:  $5.70/\sqrt{E/F_{yf}}$ ), the provisions of Appendix G shall apply for design flexural strength, otherwise Appendix F1.7 is applicable.

For design shear strength and transverse stiffener design, see appropriate sections in Chapter F, or see Appendices G3 and G4 if tension field action is utilized.

## CHAPTER H

### H. MEMBERS UNDER TORSION AND COMBINED FORCES

This section applies to prismatic members subjected to axial force and flexure about one or both axes of symmetry, with or without torsion, and torsion only. For web-tapered members, see Appendix F4.

**H1. SYMMETRIC MEMBERS SUBJECT TO BENDING AND AXIAL FORCE**

**1. Doubly and Singly Symmetric Members in Flexure and Tension.** The interaction of flexure and tension in symmetric shapes shall be limited by Formulas H1-1a and H1-1b.

for  $\frac{P_u}{\phi P_n} \geq 0.2$

$$\frac{P_u}{\phi P_n} + \frac{8}{9} \left( \frac{M_{ux}}{\phi_b M_{nx}} + \frac{M_{uy}}{\phi_b M_{ny}} \right) \leq 1.0 \quad (\text{H1-1a})$$

for  $\frac{P_u}{\phi P_n} < 0.2$

$$\frac{P_u}{2\phi P_n} + \left( \frac{M_{ux}}{\phi_b M_{nx}} + \frac{M_{uy}}{\phi_b M_{ny}} \right) \leq 1.0 \quad (\text{H1-1b})$$

**WHERE:**

$M_n$  = nominal flexural strength determined in accordance with Section F1, kip-in. (N·mm)

$M_u$  = required flexural strength, kip-in. (N·mm)

$P_n$  = nominal tensile strength determined in accordance with Section D1, kips (N)

$P_u$  = required tensile strength, kips (N)

$\phi_b$  = resistance factor for flexure = 0.90

$\phi_t$  = resistance factor for tension,  $\phi_t = 0.90$  (see Section D1)

Second order effects may be considered in the determination of  $M_u$  for use in Formulas H1-1a and H1-1b. A more detailed analysis of the interaction of flexure and tension may be made in lieu of using Formulas H1-1a and H1-1b.

**2. Doubly and Singly Symmetric Members in Flexure and Compression.** The interaction of flexure and compression in symmetric shapes shall be limited by Formulas H1-1a and H1-1b where

$M_n$  = nominal flexural strength determined in accordance with Subsection b, below, kip-in. (N·mm)

$M_u$  = required flexural strength determined in accordance with Subsection a, below, kip-in. (N·mm)

$P_n$  = nominal compressive strength determined in accordance with Section E2, kips (N)

$P_u$  = required compressive strength, kips (N)

$\phi_b$  = resistance factor for flexure = 0.90

$\phi_c$  = resistance factor for compression,  $\phi_c = 0.85$  (see Section E2)

**a. Determination of  $M_u$ .** In structures designed on the basis of elastic analysis,  $M_u$  may be determined from a second order elastic analysis using factored loads. In structures designed on the basis of plastic analysis,  $M_u$  shall be determined from a plastic analysis that satisfies the requirements of Sections C1 and C2. In structures designed on the basis of elastic first order analysis the following procedure for the determination of  $M_u$  may be used in lieu of a second order analysis:

$$M_u = B_1 M_{nt} + B_2 M_{lt} \quad (\text{H1-2})$$

**WHERE:**

$$B_1 = \frac{C_m}{(1 - P_u/P_e)} \geq 1$$

$C_m$  = a coefficient whose value shall be taken as follows:

$M_{lt}$  = required flexural strength in member as a result of lateral translation of the frame only, kip-in. (N·mm)

$M_{nt}$  = required flexural strength in member assuming there is no lateral translation of the frame, kip-in. (N·mm)

$P_e = A_g F_y / \lambda_c^2$  where  $\lambda_c$  is defined by Formula E2-4 with  $K \leq 1.0$  in the plane of bending

i. For restrained compression members in frames braced against joint translation and not subject to transverse loading between their supports in the plane of bending,

$$C_m = 0.6 - 0.4(M_1/M_2) \tag{H1-4}$$

where  $M_1/M_2$  is the ratio of the smaller to larger moments at the ends of that portion of the member unbraced in the plane of bending under consideration.  $M_1/M_2$  is positive when the member is bent in reverse curvature, negative when bent in single curvature.

ii. For compression members in frames braced against joint translation in the plane of loading and subjected to transverse loading between their supports, the value of  $C_m$  can be determined by rational analysis. In lieu of such analysis, the following values may be used:

- for members whose ends are restrained . . . . .  $C_m = 0.85$
- for members whose ends are unrestrained . . . . .  $C_m = 1.0$

$$B_2 = \frac{1}{1 - \Sigma P_u \left( \frac{\Delta_{oh}}{\Sigma HL} \right)} \tag{H1-5}$$

or

$$B_2 = \frac{1}{1 - \frac{\Sigma P_u}{\Sigma P_e}} \tag{H1-6}$$

$\Sigma P_u$  = required axial load strength of all columns in a story, kips (N)

$\Delta_{oh}$  = translation deflection of the story under consideration, in. (mm)

$\Sigma H$  = sum of all story horizontal forces producing  $\Delta_{oh}$ , kips (N)

$L$  = story height, in. (mm)

$P_e = A_g F_y / \lambda_c^2$ , kips (N/mm<sup>2</sup>), where  $\lambda_c$  is the slenderness parameter defined by Formula E2-4, in which the effective length factor,  $K$ , in the plane of bending shall be determined in accordance with Section C2.2, but shall not be less than unity.

**b. Determination of  $M_n$ .** In the use of Formulas H1-1a and H1-1b,  $M_{nx}$  shall be determined in accordance with Section F1. The actual value of  $C_b$  specified in Section F1.3 may be used, provided that the maximum moment,  $M_{ux}$ , occurs at the end of the member or at the end of an unbraced segment of a member. When the maximum moment occurs between the ends,  $M_{nx}$  shall be determined with  $C_b = 1.0$ . When Formula H1-2 is used for determining  $M_u$ , the maximum moment for a braced member bent about the strong axis and laterally braced only at its ends will occur at an end whenever the calculated value of  $B_1$  is equal to or less than 1.

**H2. UNSYMMETRIC MEMBERS AND MEMBERS UNDER TORSION AND COMBINED TORSION, FLEXURE AND/OR AXIAL FORCE**

The design strength,  $\phi F_y$ , of the member shall equal or exceed the required strength expressed in terms of the normal stress,  $f_{un}$ , or the shear stress,  $f_{uv}$ , determined by elastic analysis for the factored loads:

a. For the limit state of yielding under normal stress:

$$f_{un} \leq \phi F_y \tag{H2-1}$$

$$\phi = 0.90$$

b. For the limit state of yielding under shear stress:

$$f_{uv} \text{ or } \leq 0.6 \phi F_y \tag{H2-2}$$

$$\phi = 0.90$$

For the limit state of buckling:

$$f_{un} \text{ or } f_{uv} \leq \phi_c F_{cr}, \text{ as applicable.} \quad (\text{H2-3})$$

**WHERE:**

$\phi_c = 0.85$  and  $F_{cr}$  shall be determined from Formula A-E3-2 or E3-3, as applicable.

Some constrained local yielding shall be permitted in areas adjacent to areas which remain elastic.

**H3. ALTERNATE INTERACTION EQUATIONS FOR MEMBERS UNDER COMBINED STRESS**

See Appendix H3.

**CHAPTER I**

**COMPOSITE MEMBERS**

**General.** This chapter applies to composite columns composed of rolled or built-up structural steel shapes, pipe or tubing and structural concrete acting together and to steel beams supporting a reinforced concrete slab so interconnected that the beams and the slab act together to resist bending. Simple and continuous composite beams with shear connectors and concrete-encased beams, constructed with or without temporary shores, included.

**11. DESIGN ASSUMPTIONS**

**Force Determination.** In determining forces in members and connections of a structure that includes composite beams, consideration must be given to the effective sections at the time each increment of load is applied.

**Elastic Analysis.** For an elastic analysis of continuous composite beams without haunched ends, it is acceptable to assume that the stiffness of a beam is uniform throughout the beam length and may be computed using the moment of inertia of the composite transformed section in the positive moment region.

**Plastic Analysis.** When plastic analysis is used, the strength of flexural composite members shall be determined from plastic stress distributions as specified in I3.

**Plastic Stress Distribution for Positive Moment.** If the slab in the positive moment region is connected to the steel beam with shear connectors, a concrete stress of  $0.85f'_c$  shall be assumed uniformly distributed throughout the effective compression zone. Concrete tensile strength shall be neglected. A uniformly distributed steel stress of  $F_y$  shall be assumed throughout the tension zone and throughout the compression zone in the structural steel section. The net tensile force in the steel section shall be equal to the compressive force in the concrete slab.

**Plastic Stress Distribution for Negative Moment.** If the slab in the negative moment region is connected to the steel beam with shear connectors, a tensile stress of  $F_{yr}$  shall be assumed in all adequately developed longitudinal reinforcing bars within the effective width of the concrete slab. Concrete tensile strength shall be neglected. A uniformly distributed steel stress of  $F_y$  shall be assumed throughout the tension zone and throughout the compression zone in the structural steel section. The net compressive force in the steel section shall be equal to the total tensile force in the reinforcing steel.

**Elastic Stress Distribution.** When a determination of elastic stress distribution is required, strains in steel and concrete shall be assumed directly proportional to the distance from the neutral axis. The stress shall equal strain times  $E$  or  $E_c$ . Concrete tensile strength shall be neglected. Maximum stress in the steel shall not exceed  $F_y$ . Maximum compressive stress in the concrete shall not exceed  $0.85f'_c$ . In composite hybrid beams, the maximum stress in the steel flange shall not exceed

$F_{yf}$  but the strain in the web may exceed the yield strain; the stress shall be taken as  $F_{yw}$  at such locations.

**Fully Composite Beam.** Shear connectors are provided in sufficient numbers to develop the maximum flexural strength of the composite beam. For elastic stress distribution it shall be assumed that no slip occurs.

**Partially Composite Beam.** The shear strength of shear connectors governs the flexural strength of the partially composite beam. Elastic computations such as those for deflections, fatigue and vibrations shall include the effect of slip.

**Concrete-encased Beam.** A beam totally encased in concrete cast integrally with the slab shall be assumed to be interconnected to the concrete by natural bond, without additional anchorage, provided that: (1) concrete cover over beam sides and soffit is at least 2 inches (51 mm); (2) the top of the beam is at least 1 1/2 inches (38 mm) below the top and 2 inches (51 mm) above the bottom of the slab; and (3) concrete encasement contains adequate mesh or other reinforcing steel to prevent spalling of concrete.

**Composite Column.** A steel column fabricated from rolled or built-up steel shapes and encased in structural concrete or fabricated from steel pipe or tubing and filled with structural concrete.

## 12. COMPRESSION MEMBERS

**1. Limitations.** To qualify as a composite column, the following limitations shall be met.

a. The cross-sectional area of the steel shape, pipe or tubing must comprise at least 4 percent of the total composite cross section.

b. Concrete encasement of a steel core shall be reinforced with longitudinal load-carrying bars, longitudinal bars to restrain concrete and lateral ties. Longitudinal load carrying bars shall be continuous at framed levels; longitudinal restraining bars may be interrupted at framed levels. The spacing of ties shall be not greater than  $2/3$  of the least dimension of the composite cross section. The cross-sectional area of the transverse and longitudinal reinforcement shall be at least 0.007 square inch per inch (0.18 mm<sup>2</sup> per mm) of bar spacing. The encasement shall provide at least 1.5 inches (38 mm) of clear cover outside of both transverse and longitudinal reinforcement.

c. Concrete shall have a specified compressive  $f'_c$  strength of not less than 3 ksi (21 N/mm<sup>2</sup>) nor more than 8 ksi (55 N/mm<sup>2</sup>) for normal-weight concrete and not less than 4 ksi (28 N/mm<sup>2</sup>) for light-weight concrete.

d. The specified minimum yield stress of structural steel and reinforcing bars used in calculating the strength of a composite column shall not exceed 55 ksi (380 N/mm<sup>2</sup>).

e. The minimum wall thickness of structural steel pipe or tubing filled with concrete shall be equal to  $b \sqrt{F_y/3E}$  for each face of width  $b$  in rectangular sections and  $D \sqrt{F_y/8E}$  for circular sections of outside diameter  $D$ .

**2. Design Strength.** The design strength of axially loaded composite columns is  $\phi_c P_n$ , where  $\phi_c = 0.85$  and the nominal axial compressive strength,  $P_n$ , shall be determined from Formulas E2-1 through E2-4 with the following modifications:

a.  $A_s$  = gross area of steel shape, pipe or tubing; in.<sup>2</sup> (mm<sup>2</sup>) (replaces  $A_g$ )

$r_m$  = radius of gyration of the steel shape, pipe or tubing except that for steel shapes, it shall not be less than 0.3 times the overall thickness of the composite cross section in the plane of buckling, in. (replaces  $r$ )

b. Replace  $F_y$  with modified yield stress,  $F_{my}$ , from Formula I2-1 and replace  $E$  with modified modulus of elasticity,  $E_m$ , from Formula I2-2.

$$F_{my} = F_y + c_1 F_{yr} (A_r/A_s) + c_2 f'_c (A_c/A_s) \quad (I2-1)$$

$$E_m = E + c_3 E_c (A_c/A_s) \quad (I2-2)$$

**WHERE:**

$A_c$  = area of concrete, in.<sup>2</sup> (mm<sup>2</sup>)

$A_r$  = area of longitudinal reinforcing bars, in.<sup>2</sup> (mm<sup>2</sup>)

$A_s$  = area of steel, in.<sup>2</sup> (mm<sup>2</sup>)

$E$  = modulus of elasticity of steel, ksi (N/mm<sup>2</sup>)

$E_c$  = modulus of elasticity of concrete,\* ksi (N/mm<sup>2</sup>) as given in Section 2608 (f) of the code

$F_y$  = specified minimum yield stress of steel shape, pipe or tubing, ksi (N/mm<sup>2</sup>)

$F_{yr}$  = specified minimum yield stress of longitudinal reinforcing bars, ksi (N/mm<sup>2</sup>)

$f'_c$  = specified compressive strength of concrete, ksi (N/mm<sup>2</sup>)

$c_1, c_2,$

$c_3$  = numerical coefficients. For concrete-filled pipe and tubing:  $c_1 = 1.0$ ,  $c_2 = 0.85$  and  $c_3 = 0.4$ ; for concrete encased shapes  $c_1 = 0.7$ ,  $c_2 = 0.6$  and  $c_3 = 0.2$

**3. Columns with Multiple Steel Shapes.** If the composite cross section includes two or more steel shapes, the shapes must be interconnected with lacing, tie plates or batten plates to prevent buckling of individual shapes before hardening of concrete.

**4. Load Transfer.** The portion of the design strength of axially loaded composite columns resisted by concrete shall be developed by direct bearing at connections. When the supporting concrete area is wider than the loaded area on one or more sides and otherwise restrained against lateral expansion on the remaining sides, the maximum design strength of concrete shall be  $1.7\phi_c f'_c A_B$ , where  $\phi_c = 0.60$  is the resistance factor in bearing on concrete and  $A_B$  is the loaded area.

**13. FLEXURAL MEMBERS**

**1. Effective Width.** The portion of the effective width of the concrete slab on each side of the beam center line shall not exceed:

- a. One eighth of the beam span, center to center of supports;
- b. One half the diameter to the centerline of the adjacent beam; or
- c. The distance from the beam centerline to the edge of the slab.

**2. Strength of Beams with Shear Connectors.** 1. The positive design flexural strength,  $\phi_b M_n$ , shall be determined as follows:

- a. For  $h_c/t_w \leq 640/\sqrt{F_{yf}}$  (For SI:  $h_c/t_w \leq 3.76\sqrt{E/F_{yf}}$ ):  
 $\phi_b = 0.85$ ;  $M_n$  shall be determined from the plastic stress distribution on the composite section.
- b. For  $h_c/t_w > 640/\sqrt{F_{yf}}$  (For SI:  $h_c/t_w > 3.76\sqrt{E/F_{yf}}$ ):  
 $\phi_b = 0.90$ ;  $M_n$  shall be determined from the superposition of elastic stresses, considering the effects of shoring.

The negative design flexural strength,  $\phi_b M_n$ , shall be determined for the steel section alone, in accordance with the requirements of Section F.

Alternatively, the negative design flexural strength,  $\phi_b M_n$ , may be computed with  $\phi_b = 0.85$  and  $M_n$  determined from the plastic stress distribution on the composite section, provided that:

- a. Steel beam is an adequately braced compact section, as defined in Section B5.
- b. Shear connectors connect the slab to the steel beam in the negative moment region.

\* $E_c$  may be computed from  $E_c = w^{1.5} \sqrt{f'_c}$  (For SI:  $E_c = 0.041 w^{1.5} \sqrt{f'_c}$ ) where  $w$ , the unit weight of concrete, is expressed in lbs./cu.ft. (kg/m<sup>3</sup>) and  $f'_c$  is expressed in ksi (N/mm<sup>2</sup>).

c. Slab reinforcement parallel to the steel beam, within the effective width of the slab, is properly developed.

**3. Strength of Concrete-encased Beams.** The design flexural strength,  $\phi_b M_n$ , shall be computed with  $\phi_b = 0.90$  and  $M_n$  determined from the superposition of elastic stresses, considering the effects of shoring.

Alternatively, the design flexural strength,  $\phi_b M_n$ , may be computed with  $\phi_b = 0.90$  and  $M_n$  determined from the plastic stress distribution on the steel section alone.

**4. Strength During Construction.** When temporary shores are not used during construction, the steel section alone shall have adequate strength to support all loads applied prior to the concrete attaining 75 percent of its specified strength,  $f'_c$ . The design flexural strength of the steel section shall be determined in accordance with the requirements of Section F1.

#### 5. Formed Steel Deck

**a. General.** The design flexural strength,  $\phi_b M_n$ , of composite construction consisting of concrete slabs on formed steel deck connected to steel beams shall be determined by the applicable portions of Section I3.2, with the following modifications:

This section is applicable to decks with nominal rib height not greater than 3 inches (76 mm). The average width of concrete rib or haunch,  $w_r$ , shall be not less than 2 inches (51 mm) but shall not be taken in calculations as more than the minimum clear width near the top of the steel deck. See Section I3.5c for additional restrictions.

The concrete slab shall be connected to the steel beam with welded stud shear connectors  $3/4$  inch (19 mm) or less in diameter. Studs may be welded either through the deck or directly to the steel beam. Stud shear connectors, after installation, shall extend not less than  $1\frac{1}{2}$  inches (38 mm) above the top of the steel deck.

The slab thickness above the steel deck shall not be less than 2 inches (51 mm).

**b. Deck Ribs Oriented Perpendicular to Steel Beam.** Concrete below the top of the steel deck shall be neglected in determining section properties and in calculating  $A_c$  for deck ribs oriented perpendicular to the steel beams.

The spacing of stud shear connectors along the length of a supporting beam shall not exceed 32 inches (815 mm).

The nominal strength of a stud shear connector shall be the value stipulated in Section I5 multiplied by the following reduction factor:

$$\frac{0.85}{\sqrt{N_r}} (w_r/h_r) [(H_s/h_r) - 1.0] \leq 1.0 \quad (I3-1)$$

#### WHERE:

$h_r$  = nominal rib height, in. (mm)

$H_s$  = length of stud connector after welding, in. (mm), not to exceed the value  $(h_r + 3)$  [For SI:  $(h_r + 75$  mm)] in computations, although actual length may be greater

$N_r$  = number of stud connectors in one rib at a beam intersection, not to exceed three in computations, although more than three studs may be installed

$w_r$  = average width of concrete rib or haunch (as defined in Section I3.5a), in.

To resist uplift, steel deck shall be anchored to all supporting members at a spacing not to exceed 16 inches (410 mm). Such anchorage may be provided by stud connectors, a combination of stud connectors and arc spot (puddle) welds or other devices specified by the designer.

**c. Deck Ribs Oriented Parallel to Steel Beam.** Concrete below the top of the steel deck may be included in determining section properties and shall be included in calculating  $A_c$  in Section I5.

Steel deck ribs over supporting beams may be split longitudinally and separated to form a concrete haunch.

When the nominal depth of steel deck is  $1\frac{1}{2}$  inches (38 mm) or greater, the average width,  $w_r$ , of the supported haunch or rib shall be not less than 2 inches (51 mm) for the first stud in the transverse row, plus 4 stud diameters for each additional stud.

The nominal strength of a stud shear connector shall be the value specified in Section I5, except that when  $w_r/h_r$  is less than 1.5, the value from Section I.5 shall be multiplied by the following reduction factor:

$$0.6 (w_r/h_r) [(H_s/h_r) - 1.0] \leq 1.0 \quad (\text{I3-2})$$

where  $h_r$  and  $H_s$  are as defined in Section I3.5b and  $w_r$  is the average width of concrete rib or haunch as defined in Section I3.5a.

**6. Design Shear Strength.** The design shear strength of composite beams shall be determined by the shear strength of the steel web, in accordance with Section F2.

#### 14. COMBINED COMPRESSION AND FLEXURE

The interaction of axial compression and flexure in the plane of symmetry on composite members shall be limited by Formulas H1-1 through H1-6 with the following modifications:

$F_{my}$  = modified yield stress, ksi (N/mm<sup>2</sup>), see Section I2

$M_n$  = nominal flexural strength determined from plastic stress distribution on the composite cross section except as provided below, kip-in. (N-mm)

$P_e$  =  $A_s F_{my} / \lambda_c^2$ , elastic buckling load, kips (N)

$\lambda_c$  = column slenderness parameter defined by Formula E2-4 as modified in Section I2.2

$\phi_b$  = resistance factor for flexure from Section I3

$\phi_c$  = 0.85

When the axial term in Formulas H1-1a and H1-1b is less than 0.3, the nominal flexural strength,  $M_n$ , shall be determined by straight-line transition between the nominal flexural strength determined from the plastic distribution on the composite cross sections at  $(P_u/\phi_b P_n) = 0.3$  and the flexural strength at  $P_u = 0$  as determined in Section I3. If shear connectors are required at  $P_u = 0$ , they shall be provided whenever  $P_u/\phi_b P_n$  is less than 0.3.

#### 15. SHEAR CONNECTORS

This section applies to the design of stud and channel shear connectors. The design of connectors of other types, shall be in accordance with Section I6.

**1. Materials.** Shear connectors shall be headed steel studs not less than four stud diameters in length after installation, or hot-rolled steel channels. The stud connectors shall conform to the requirements of Section A3.6. The channel connectors shall conform to the requirements of Section A3. Shear connectors shall be embedded in concrete slabs made with ASTM C 33 aggregate or with rotary kiln produced aggregates conforming to ASTM C 330, with concrete unit weight not less than 90 pcf (1440 kg/m<sup>3</sup>).

**2. Horizontal Shear Force.** Except for concrete-encased beams as defined in Section I1, the entire horizontal shear at the interface between the steel beam and the concrete slab shall be assumed to be transferred by shear connectors. For composite action with concrete subject to flexural compression, the total horizontal shear force between the point of maximum positive moment and the point of zero moment shall be taken as the smallest of the following: (1)  $0.85 f'_c A_c$ ; (2)  $A_s F_y$ ;<sup>\*</sup> and (3)  $\Sigma Q_n$ .

#### WHERE:

$A_c$  = area of concrete slab within effective width, in.<sup>2</sup> (mm<sup>2</sup>)

<sup>\*</sup>For hybrid beams, the yield force must be computed separately for each component of the cross section;  $A_s F_y$  of the entire cross section is the sum of the component yield forces.

- $A_s$  = area of steel cross section, in.<sup>2</sup> (mm<sup>2</sup>)  
 $f'_c$  = specified compressive strength of concrete, ksi (N/mm<sup>2</sup>)  
 $F_y$  = minimum specified yield stress, ksi (N/mm<sup>2</sup>)  
 $\Sigma Q_n$  = sum of nominal strengths of shear connectors between the point of maximum positive moment and the point of zero moment, kips (N)

In continuous composite beams where longitudinal reinforcing steel in the negative moment regions is considered to act compositely with the steel beam, the total horizontal shear force between the point of maximum negative moment and the point of zero moment shall be taken as the smaller of  $A_r F_{yr}$  and  $\Sigma Q_n$ ;

**WHERE:**

- $A_r$  = area of adequately developed longitudinal reinforcing steel within the effective width of the concrete slab, in.<sup>2</sup> (mm<sup>2</sup>)  
 $F_{yr}$  = minimum specified yield stress of the reinforcing steel, ksi (N/mm<sup>2</sup>)  
 $\Sigma Q_n$  = sum of nominal strengths of shear connectors between the point of maximum negative moment and the point of zero moment, kips (N)

**3. Strength of Stud Shear Connectors.** The nominal strength of one stud shear connector embedded in a solid concrete slab is

$$Q_n = 0.5 A_{sc} \sqrt{f'_c E_c} \leq A_{sc} F_u \quad (15-1)$$

**WHERE:**

- $A_{sc}$  = cross-sectional area of a stud shear connector, in.<sup>2</sup> (mm<sup>2</sup>)  
 $E_c$  = modulus of elasticity of concrete, \*ksi (N/mm<sup>2</sup>)  
 $f'_c$  = specified compressive strength of concrete, ksi (N/mm<sup>2</sup>)  
 $F_u$  = minimum specified tensile strength of a stud shear connector, ksi (N/mm<sup>2</sup>)

For a stud shear connector embedded in a slab on a formed steel deck, refer to Section I3 for reduction factors given by Formulas I3-1 and I3-2 as applicable. The reduction factors should be applied only to  $0.5A_{sc} \sqrt{f'_c E_c}$  term in Formula I5-1.

**4. Strength of Channel Shear Connectors.** The nominal strength of one channel shear connector embedded in a solid concrete slab is

$$Q_n = 0.3 (t_f + 0.5 t_w) L_c \sqrt{f'_c E_c} \quad (15-2)$$

**WHERE:**

- $L_c$  = length of channel shear connector, in. (mm)  
 $t_f$  = flange thickness of channel shear connector, in. (mm)  
 $t_w$  = web thickness of channel shear connector, in. (mm)

**5. Required Number of Shear Connectors.** The number of shear connectors required between the section of maximum bending moment, positive or negative, and the adjacent section of zero moment shall be equal to the horizontal shear force as determined in Section I5.2 divided by the nominal strength of one shear connector as determined from Section I5.3 or Section I5.4.

**6. Shear Connector Placement and Spacing.** Shear connectors required on each side of the point of maximum bending moment, positive or negative, may be distributed uniformly between that point and the adjacent points of zero moment. However, the number of shear connectors placed between any concentrated load and the nearest point of zero moment shall be sufficient to develop the maximum moment required at the concentrated load point.

---

\* $E_c$  may be computed from  $E_c = w^{1.5} \sqrt{f'_c}$  (For SI:  $E_c = 0.041 w^{1.5} \sqrt{f'_c}$  ) where  $w$ , the unit weight of concrete, is expressed in lbs./cu.ft. (kg/m<sup>3</sup>) and  $f'_c$  is expressed in ksi (N/mm<sup>2</sup>).

Except for connectors installed in the ribs of formed steel decks, shear connectors shall have at least 1 inch (25 mm) of lateral concrete cover. Unless located over the web, the diameter of studs shall not be greater than 2.5 times the thickness of the flange to which they are welded. The minimum center to center spacing of stud connectors shall be 6 diameters along the longitudinal axis of the supporting composite beam and 4 diameters transverse to the longitudinal axis of the supporting composite beam, except that within the ribs of formed steel decks the center to center spacing may be as small as 4 diameters in any direction. The maximum center to center spacing of shear connectors shall not exceed 8 times the total slab thickness.

## 16. SPECIAL CASES

When composite construction does not conform to the requirements of Section I1 through Section I5, the strength of shear connectors and details of construction shall be established by a suitable test program.

# CHAPTER J

## CONNECTIONS, JOINTS AND FASTENERS

### J1. GENERAL PROVISIONS

**1. Design Basis.** Connections consist of connecting elements (e.g., stiffeners, gussets, angles, brackets) and connectors (welds, bolts, rivets). These components shall be proportioned so that their design strength equals or exceeds the required strength determined by (a) structural analysis for factored loads acting on the structure or (b) a specified proportion of the strength of the connected members, whichever is appropriate.

**2. Simple Connections.** Except as otherwise indicated in the design documents, connections of beams, girders or trusses shall be designed as flexible, and may ordinarily be proportioned for the reaction shears only. Flexible beam connections shall accommodate end rotations of unrestrained (simple) beams. To accomplish this, inelastic deformation in the connection is permitted.

**3. Moment Connections.** End connections of restrained beams, girders and trusses shall be designed for the combined effect of forces resulting from moment and shear induced by the rigidity of the connections.

**4. Compression Members with Bearing Joints.** When columns bear on bearing plates or are finished to bear at splices, there shall be sufficient connectors to hold all parts securely in place.

When other compression members are finished to bear, the splice material and its connectors shall be arranged to hold all parts in line and shall be proportioned for 50 percent of the factored strength of the member.

All compression joints shall be proportioned to resist any tension developed by the factored loads specified by Formula A4-6.

**5. Minimum Strength of Connections.** Except for lacing, sag rods or girts, connections providing design strength shall be designed to support a factored load not less than 10 kips (44.5 kN).

**6. Placement of Welds and Bolts.** Groups of welds or bolts at the ends of any member which transmit axial force into that member shall be sized so that the center of gravity of the group coincides with the center of gravity of the member, unless provision is made for the eccentricity. The foregoing provision is not applicable to end connections of statically-loaded single angle, double angle and similar members.

**7. Bolts in Combination with Welds.** In new work, A307 bolts or high-strength bolts proportioned as bearing-type connections shall not be considered as sharing the load in combination with

welds. Welds, if used, shall be provided to carry the entire force in the connection. High-strength bolts proportioned for slip-critical connections may be considered as sharing the load with the welds.

In making welded alterations to structures, existing rivets and high-strength bolts tightened to the requirements for slip-critical connections may be utilized for carrying loads resulting from existing dead loads, and the welding need only provide the additional design strength required.

**8. High-strength Bolts in Combination with Rivets.** In both new work and alterations, in connections designed as slip-critical connections in accordance with the provisions of Section J3, high-strength bolts may be designed to share the load with rivets.

**9. Limitations on Bolted and Welded Connections.** Fully tensioned high-strength bolts (see Table J3.1) or welds shall be used for the following connections:

Column splices in all tier structures 200 feet (60 960 mm) or more in height.

Column splices in tier structures 100 to 200 feet (30 480 mm to 60 960 mm) in height, if the least horizontal dimension is less than 40 percent of the height.

Column splices in tier structures less than 100 feet (30 480 mm) in height, if the least horizontal dimension is less than 25 percent of the height.

Connections of all beams and girders to columns and of any other beams and girders on which the bracing of columns is dependent, in structures over 125 feet (38 100 mm) in height.

In all structures carrying cranes of over 5-ton (44.5 kN) capacity: roof-truss splices and connections of trusses to columns, column splices, column bracing, knee braces and crane supports.

Connections for supports of running machinery, or of other live loads which produce impact or reversal of stress.

Any other connections stipulated on the design plans.

In all other cases connections may be made with A307 bolts or snug-tight high-strength bolts.

For the purpose of this Section, the height of a tier structure shall be taken as the vertical distance from the curb level to the highest point of the roof beams in the case of flat roofs, or to the mean height of the gable in the case of roofs having a slope of more than  $2\frac{2}{3}$  in 12 (2.22 in 10). Where the curb level has not been established, or where the structure does not adjoin a street, the mean level of the adjoining land shall be used instead of curb level. Penthouses may be excluded in computing the height of structure.

## 10. Splices In Heavy Sections

This paragraph applies to ASTM A6 Group 4 and 5 rolled shapes, or shapes built-up by welding plates more than 2 inches (51 mm) thick together to form the cross section,\* and where the cross section is to be spliced and subject to primary tensile stresses due to tension or flexure. When tensile forces in these sections are to be transmitted through splices by full-penetration groove welds, material notch-toughness requirements as given in Section A3.1a, weld across hole details as given in J1.11, welding preheat requirements as given in J2.7 and the thermal-cut surface preparation and inspection requirements as given in M2.2 apply.

At tension splices in Group 4 and 5 shapes and built-up members of material more than 2 inches (51 mm) thick, weld tabs and backing shall be removed and the surfaces ground smooth.

When splicing ASTM A6 Group 4 and 5 rolled shapes or shapes built-up by welding plates more than 2 inches (51 mm) thick to form a cross section, and where the section is to be used as a primary

---

\*When the individual elements of the cross section are spliced prior to being joined to form the cross section in accordance with ASW D1.1, Article 3.4.6, the applicable provisions of AWS D1.1 apply in lieu of the requirement of this section.

compression member, all weld access holes required to facilitate groove welding operations shall satisfy the provisions of J1.11.

Alternatively, splicing of such members subject to compression, including members which are subject to tension due to wind or seismic loads, may be accomplished using splice details which do not induce large weld shrinkage strains such as partial penetration flange groove welds with fillet-welded surface lap plate splices on the web or with bolted or combination bolted/fillet-welded lap plate splices.

### 11. Beam Copes and Weld Access Holes

All weld access holes required to facilitate welding operations shall have a length from the toe of the weld preparation not less than  $1\frac{1}{2}$  times the thickness of the material in which the hole is made. The height of the access hole shall be adequate for deposition of sound weld metal in the adjacent plates and provide clearance for weld tabs for the weld in the material in which the hole is made but not less than the thickness of the material. In hot-rolled shapes and built-up shapes, all beam copes and weld access holes shall be shaped free of notches or sharp reentrant corners except when fillet web-to-flange welds are used in built-up shapes, access holes are permitted to terminate perpendicular to the flange.

For Group 4 and 5 shapes and built-up shapes of material more than 2 inches (51 mm) thick, the thermally cut surfaces of beam copes and weld access holes shall be ground to bright metal and inspected by either magnetic particle or dye penetrant methods. If the curved transition portion of weld access holes and beam copes are formed by predrilled or sawed holes, that portion of the access hole or cope need not be ground. Weld access holes and beam copes in other shapes need not be ground nor inspected by dye penetrant or magnetic particle.

## J2. WELDS

All provisions of American Welding Society *Structural Welding Code—Steel*, AWS D1.1, except Sections 2.3, 2.4, 2.5, 8.13.1, 9, and 10 as applicable, apply to work performed under this Specification.

### 1. Groove Welds

**a. Effective Area.** The effective area of groove welds shall be considered as the effective length of the weld times the effective throat thickness.

The effective length of a groove weld shall be the width of the part joined.

The effective throat thickness of a complete-penetration groove weld shall be the thickness of the thinner part joined.

The effective throat thickness of a partial-penetration groove weld shall be as shown in Table J2.1.

The effective throat thickness of a flare groove weld when flush to the surface of a bar or 90° bend in a formed section shall be as shown in Table J2.2. Random sections of production welds for each welding procedure, or such test sections as may be required by design documents, shall be used to verify that the effective throat is consistently obtained.

Larger effective throat thicknesses than those in Table J2.2 are permitted, provided the fabricator can establish by qualification that he can consistently provide such larger effective throat thicknesses. Qualification shall consist of sectioning the weld normal to its axis, at mid-length and terminal ends. Such sectioning shall be made on a number of combinations of material sizes representative of the range to be used in the fabrication or as required by the designer.

**b. Limitations.** The minimum effective throat thickness of a partial-penetration groove weld shall be as shown in Table J2.4. Weld size is determined by the thicker of the two parts joined, except that the weld size need not exceed the thickness of the thinnest part joined when a larger size is required

by calculated strength. For this exception, particular care shall be taken to provide sufficient preheat for soundness of the weld.

TABLE J2.1  
Effective Throat Thickness of Partial Penetration Groove Welds

Welding Process	Welding Position	Included Angle at Root of Groove	Effective Throat Thickness
Shielded metal arc Submerged arc Gas metal arc Flux-cored arc	All	J or U joint	Depth of chamfer
		Bevel or V joint ≥ 60°	
		Bevel or V joint < 60° but ≥ 45°	Depth of chamfer minus 1/8-in. (3 mm)

TABLE J2.2  
Effective Throat Thickness of Flare Groove Welds

Type of Weld	Radius (R) of Bar or Bend	Effective Throat Thickness
Flare bevel groove	All	$5/16 R$
Flare V-groove	All	$1/2 R^*$
*Use $3/8 R$ for Gas Metal Arc Welding (except short circuiting transfer process) when $R \geq 1$ in. (25 mm)		

## 2. Fillet Welds

**a. Effective Area.** The effective area of fillet welds shall be taken as the effective length times the effective throat thickness.

The effective length of fillet welds, except fillet welds in holes and slots, shall be the overall length of full-size fillets, including returns.

The effective throat thickness of a fillet weld shall be the shortest distance from the root of the joint to the face of the diaphragmatic weld, except that for fillet welds made by the submerged arc process, the effective throat thickness shall be taken equal to the leg size for 3/8 inch (9.5 mm) and smaller fillet welds, and equal to the theoretical throat plus 0.11 inch (2.8 mm) for fillet welds over 3/8 inch (9.5 mm).

For fillet welds in holes and slots, the effective length shall be the length of the centerline of the weld along the center of the plane through the throat. In the case of overlapping fillets, the effective area shall not exceed the nominal cross-sectional area of the hole or slot, in the plane of the faying surface.

**b. Limitations.** The *minimum size of fillet welds* shall be as shown in Table J2.5.

TABLE J2.4  
Minimum Effective Throat Thickness of  
Partial-penetration Groove Welds

Material Thickness of Thicker Part Joined (in.)	Minimum Effective Throat Thickness <sup>a</sup> (in.)
× 25.4 for mm	
To 1/4 inclusive	1/8
Over 1/4 to 1/2	3/16
Over 1/2 to 3/4	1/4
Over 3/4 to 1 1/2	5/16
Over 1 1/2 to 2 1/4	3/8
Over 2 1/2 to 6	1/2
Over 6	5/8
<sup>a</sup> See Sect. J2.	

TABLE J2.5  
Minimum Size of Fillet Welds

Material Thickness of Thicker Part Joined (in.)	Minimum Size of Fillet Weld <sup>a</sup> (in.)
× 25.4 for mm	
To 1/4 inclusive	1/8
Over 1/4 to 1/2	3/16
Over 1/2 to 3/4	1/4
Over 3/4	5/16
<sup>a</sup> Leg dimension of fillet welds.	

Minimum weld size is determined by the thicker of the two parts joined, except that the weld size need not exceed the thickness of the thinner part. For this exception, particular care shall be taken to provide sufficient preheat for soundness of the weld. Weld sizes larger than the thinner part joined are permitted if required by calculated strength. In the as-welded condition, the distance between the edge of the base metal and the toe of the weld may be less than 1/16 inch (1.6 mm) provided the weld size is clearly verifiable.

The *maximum size of fillet welds* that may be used along edges of connected parts shall be:

Along edges of material less than 1/4-inch (6.4 mm) thick, not greater than the thickness of the material.

Along edges of material 1/4 inch (6.4 mm) or more in thickness, not greater than the thickness of the material minus 1/16 inch (1.6 mm), unless the weld is especially designated on the drawings to be built out to obtain full-throat thickness.

The *effective length of fillet welds* designed on the basis of strength shall not be less than 4 times the nominal size, or else the size of the weld shall be considered not to exceed one fourth of its effective length. If longitudinal fillet welds are used alone in end connections of flat bar tension members, the length of each fillet weld shall be not less than the perpendicular distance between them. The transverse spacing of longitudinal fillet welds used in end connections of tension members shall not exceed 8 inches (203 mm), unless the member is designed on the basis of effective net area in accordance with Section B3.

*Intermittent fillet welds* may be used to transfer calculated stress across a joint or faying surfaces when the strength required is less than that developed by a continuous fillet weld of the smallest

permitted size, and to join components of built-up members. The effective length of any segment of intermittent fillet welding shall be not less than four times the weld size, with a minimum of 1½ inches (38 mm).

In *lap joints*, the minimum amount of lap shall be five times the thickness of the thinner part joined, but not less than 1 inch (25 mm). Lap joints joining plates or bars subjected to axial stress shall be fillet welded along the end of both lapped parts, except where the deflection of the lapped parts is sufficiently restrained to prevent opening of the joint under maximum loading.

*Side or end fillet welds* terminating at ends or sides, respectively, of parts or members shall, wherever practical, be returned continuously around the corners for a distance not less than two times the nominal size of the weld. This provision shall apply to side and top fillet welds connecting brackets, beam seats and similar connections, on the plane about which bending moments are computed. For framing angles and simple end plate connections which depend upon flexibility of the outstanding legs for connection flexibility, end returns shall not exceed four times the nominal size of the weld. Fillet welds which occur on opposite sides of a common plane shall be interrupted at the corner common to both welds. End returns shall be indicated on the design and detail drawings.

*Fillet welds in holes or slots* may be used to transmit shear in lap joints or to prevent the buckling or separation of lapped parts and to join components of built-up members. Such fillet welds may overlap, subject to the provisions of Section J2. Fillet welds in holes or slots are not to be considered plug or slot welds.

### 3. Plug and Slot Welds

**a. Effective Area.** The effective shearing area of plug and slot welds shall be considered as the nominal cross-sectional area of the hole or slot in the plane of the faying surface.

**b. Limitations.** Plug or slot welds may be used to transmit shear in lap joints or to prevent buckling of lapped parts and to join component parts of built-up members.

The diameter of the holes for a plug weld shall not be less than the thickness of the part containing it plus 5/16 inch (7.9 mm), rounded to the next larger odd 1/16 inch (1.6 mm), or greater than two and one-fourth times the thickness of the weld metal.

The minimum center-to-center spacing of plug welds shall be four times the diameter of the hole.

The length of slot for a slot weld shall not exceed 10 times the thickness of the weld. The width of the slot shall not be less than the thickness of the part containing it plus 5/16 inch (7.9 mm), rounded to the next larger odd 1/16 inch (1.6 mm), nor shall it be larger than two and one-fourth times the thickness of the weld. The ends of the slot shall be semicircular or shall have the corners rounded to a radius not less than the thickness of the part containing it, except those ends which extend to the edge of the part.

The minimum spacing of lines of slot welds in a direction transverse to their length shall be four times the width of the slot. The minimum center-to-center spacing in a longitudinal direction on any line shall be two times the length of the slot.

The thickness of plug or slot welds in material 5/8 inch (16 mm) or less in thickness shall be equal to the thickness of the material. In material over 5/8 inch (16 mm) in thickness, the thickness of the weld shall be at least one half the thickness of the material but not less than 5/8 inch (16 mm).

**4. Design Strength.** The design strength of welds shall be the lower value of  $\phi F_{BM}$  and  $\phi F_w$ , when applicable, where  $F_{BM}$  and  $F_w$  are the nominal strengths of the base material and the weld electrode material, respectively. The values of  $\phi$ ,  $F_{BM}$  and  $F_w$  and limitations thereon are given in Table J2.3.

**5. Combination of Welds.** If two or more of the general types of welds (groove, fillet, plug, slot) are combined in a single joint, the design strength of each shall be separately computed with reference to the axis of the group in order to determine the design strength of the combination.

**6. Matching Steel.** The choice of electrode for use with complete-penetration groove welds subject to tension normal to the effective area is dictated by the requirements for matching steels given in approved national standards.

**7. MIXED WELD METAL**

When notch-toughness is specified, the process consumables for all weld metal, tack welds, root pass and subsequent passes, deposited in a joint shall be compatible to assure notch-tough composite weld metal.

**8. PREHEAT FOR HEAVY SHAPES**

For A6 Group 4 and 5 shapes and welded built-up members made of plates more than 2 inches (51 mm) thick, a preheat equal to or greater than 350°F. (176.7°C.) shall be used when making groove-weld splices.

**J3. BOLTS, THREADED PARTS AND RIVETS**

**1. High-strength Bolts.** Except as otherwise provided in this standard, use of high-strength bolts shall conform to the provisions of Chapter 22, Division IV.

If required to be tightened to more than 50 percent of their minimum specified tensile strength, A449 bolts in tension and bearing-type shear connections shall have a F436 hardened washer installed under the bolt head, and the nuts shall meet the requirements of A563. When assembled, all joint surfaces, including those adjacent to the washers, shall be free of scale, except tight mill scale. Except as noted below, all A325 and A490 bolts shall be tightened to a bolt tension not less than that given in Table J3.1. Tightening shall be done by the turn-of-nut method, a direct tension indicator or by calibrated wrench.

TABLE J2.3  
Design Strength of Welds

Types of Weld and Stress <sup>a</sup>	Material	Resistance Factor $\phi$	Nominal strength $F_{DM}$ or $F_w$	Required Weld strength level <sup>b,c</sup>
Complete Penetration Groove Weld				
Tension normal to effective area	Base	0.90	$F_y$	"Matching" weld must be used.
Compression normal to effective area	Base	0.90	$F_y$	Weld metal with a strength level equal to or less than "matching" may be used.
Tension or compression parallel to axis of weld				
Shear on effective area	Base weld electrode	0.90 0.80	$0.60F_y$ $0.60F_{EXX}$	
Partial Penetration Groove Welds				
Compression normal to effective area	Base	0.90	$F_y$	Weld metal with a strength level equal to or less than "matching" weld metal may be used.
Tension or compression parallel to axis of weld <sup>d</sup>				
Shear parallel to axis of weld	Base <sup>e</sup> weld electrode	0.75	$0.60F_{EXX}$	
Tension normal to effective area	Base weld electrode	0.90 0.80	$F_y$ $0.60F_{EXX}$	
Fillet Welds				
Stress on effective area	Base <sup>e</sup> weld electrode	0.75	$0.60F_{EXX}$	Weld metal with a strength level equal to or less than "matching" weld metal may be used.
Tension or compression parallel to axis of weld <sup>d</sup>	Base	0.90	$F_y$	
Plug or Slot Welds				
Shear parallel to faying surfaces (on effective area)	Base <sup>e</sup> weld electrode	0.75	$0.60F_{EXX}$	Weld metal with a strength level equal to or less than "matching" weld metal may be used.
<sup>a</sup> For definition of effective area, see Sect. J2. <sup>b</sup> For "matching" weld metal, see Table 4.1.1, AWS D1.1. <sup>c</sup> Weld metal one strength level stronger than "matching" weld metal will be permitted. <sup>d</sup> Fillet welds and partial-penetration groove welds joining component elements of built-up members, such as flange-to-web connections, may be designed without regard to the tensile or compressive stress in these elements parallel to the axis of the welds. <sup>e</sup> The design of connected material is governed by Sect. J4.				

TABLE J3.1  
Minimum Bolt Tension, kips<sup>a</sup>  
(× 4448 for N)

Bolt Size, in.	A325 Bolts	A490 Bolts
× 25.4 for mm		
1/2	12	15
5/8	19	24
3/4	28	35
7/8	39	49
1	51	64
1 1/8	56	80
1 1/4	71	102
1 3/8	85	121
1 1/2	103	148

<sup>a</sup>Equal to 0.70 of minimum tensile strength of bolts, rounded off to nearest kip, as specified in ASTM specifications for A325 and A490 bolts with UNC threads.

Bolts in connections not subject to tension loads, where slip can be permitted and where loosening or fatigue due to vibration or load fluctuations are not design considerations, need only to be tightened to the snug-tight condition. The snug-tight condition is defined as the tightness attained by a few impacts of an impact wrench or the full effort of a worker with an ordinary spud wrench and must bring the connected plies into firm contact. The nominal strength value given in Table J3.2 for bearing-type connections shall be used for bolts tightened to the snug-tight condition. Bolts to be tightened only to the snug-tight condition shall be clearly identified on the design and erection drawings.

**2. Effective Bearing Area.** The effective bearing area of bolts, threaded parts and rivets shall be the diameter multiplied by the length in bearing, except that for countersunk bolts and rivets, one half the depth of the countersink shall be deducted.

**3. Design Tension or Shear Strength.** The design strength of bolts and threaded parts shall be taken as the product of the resistance factor,  $\phi$ , and the nominal strength given in Table J3.2 of the unthreaded nominal body area of bolts and threaded parts other than upset rods (see Footnote c of Table J3.2). High-strength bolts required to support the applied load by means of direct tension shall be proportioned so that their average required strength, computed on the basis of nominal bolt area and independent of any initial tightening force, will not exceed the design strength. The applied load shall be the sum of the factored external loads and any tension resulting from prying action produced by deformation of the connected parts.

TABLE J3.2  
Design Strength of Fasteners

Description of Fasteners	Tensile Strength		Shear Strength in Bearing-type Connections	
	× 6.89 for N/mm <sup>2</sup>			
Description of Fasteners	Resistance Factor $\phi$	Nominal Strength, ksi	Resistance Factor $\phi$	Nominal Strength, ksi
A307 bolts	0.75	45.0 <sup>a</sup>	0.60	27.0 <sup>b,e</sup>
A325 bolts, when threads are <i>not</i> excluded from shear planes		90.0 <sup>d</sup>	0.65	54.0 <sup>e</sup>
A325 bolts, when threads are <i>are</i> excluded from shear planes		90.0 <sup>d</sup>		72.0 <sup>e</sup>
A490 bolts, when threads are <i>not</i> excluded from shear planes		112.5 <sup>d</sup>		67.5 <sup>e</sup>
A490 bolts, when threads are <i>are</i> excluded from the shear planes		112.5 <sup>d</sup>		90.0 <sup>e</sup>
Threaded parts meeting the requirements of Sect. A3, when threads are <i>not</i> excluded from the shear planes		$0.75F_u$ <sup>a,c</sup>		$0.45F_u$
Threaded parts meeting the requirements of Sect. A3, when threads are <i>are</i> excluded from the shear planes		$0.75F_u$ <sup>a,c</sup>		$0.60F_u$
A502, Gr. 1, hot-driven rivets		45.0 <sup>a</sup>		36.0 <sup>e</sup>
A502, Gr. 2 & 3, hot-driven rivets		60.0 <sup>a</sup>		48.0 <sup>e</sup>

<sup>a</sup>Static loading only.  
<sup>b</sup>Threads permitted in shear planes.  
<sup>c</sup>The nominal tensile strength of the threaded portion of an upset rod, based upon the cross-sectional area at its major diameter,  $A_b$ , shall be larger than the nominal body area of the rod before upsetting times  $F_y$ .  
<sup>d</sup>For A 325 and A490 bolts subject to tensile fatigue loading, see Appendix K4.  
<sup>e</sup>When bearing-type connections used to splice tension members have a fastener pattern whose length, measured parallel to the line of force, exceeds 50 in. (1270 mm), tabulated values shall be reduced by 20%.

TABLE J3.3  
Tension Stress Limit ( $F_t$ ), ksi, for Fasteners  
in Bearing-type Connections

Description of Fasteners	Threads Included in the Shear Plane	Threads Excluded from the Shear Plane
	× 6.89 for N/mm <sup>2</sup>	
A307 bolts	$39 - 1.8f_v \leq 30$	
A325 bolts	$85 - 1.8f_v \leq 68$	$85 - 1.4f_v \leq 68$
A490 bolts	$106 - 1.8f_v \leq 84$	$106 - 1.4f_v \leq 84$
Threaded parts A 449 bolts over 1 1/2-in. diameter	$0.73F_u - 1.8f_v \leq 0.56F_u$	$0.73F_u - 1.4f_v \leq 0.56F_u$

A502 Gr. 1 rivets	$44 - 1.3t_r \leq 34$
A502 Gr. 2 rivets	$59 - 1.3t_r \leq 45$

**4. Combined Tension and Shear in Bearing-type Connections.** Bolts and rivets subject to combined tension and shear shall be so proportioned that the tension stress,  $f_t$ , produced by factored loads on the nominal body area,  $A_b$ , does not exceed the values computed from the formulas in Table J3.3. The value of  $f_y$ , the shear produced by the same factored loads, shall not exceed the values for shear given in Section J3.3.

**5. High-strength Bolts in Slip-critical Joints.** The design shear resistance of slip-critical joints shall be determined by using the tabulated values from Table J3.4 multiplied by  $\phi = 1.0$ , except  $\phi = 0.85$  for the long-slotted holes when the load is in the direction of the slot. The shear on the bolt due to service loads shall be less than the tabulated values. When the loading combination includes wind or seismic loads in addition to dead and live loads, the total of the combined load effects, at service loads, may be multiplied by 0.75 in accordance with ANSI 58.1.

When specified by the designer, the nominal slip resistance for connections having special faying surface conditions may be increased to the applicable values in RCSC Load and the Resistance Factor Design Specification.

When a bolt in a slip-critical connection is subjected to a service tensile force  $T$ , the nominal resistance in Table J3.4 shall be multiplied by the reduction factor  $(1 - T/T_b)$  where  $T_b$  is the minimum pretension load from Table J3.1.

**6. Bearing Strength at Bolt Holes.** When  $L$  is not less than  $1\frac{1}{2}d$  and the distance center to center of bolts is not less than  $3d$ , the design bearing strength on two or more bolts in the line of force is  $\phi R_n$ , where  $\phi = 0.75$ .

TABLE J3.4  
Nominal Slip-critical Shear Strength, ksi,  
of High-strength Bolts<sup>a</sup>

Type of Bolt	Nominal Shear Strength		
	× 6.89 for N/mm <sup>2</sup>		
	Standard Size Holes	Oversized and Short-slotted Holes	Long-slotted Holes <sup>b</sup>
A325	17	15	12
A490	21	18	15

<sup>a</sup>Class A (slip coefficient 0.33). Clean mill scale and blast cleaned surfaces with Class A coatings. For design strengths with other coatings see RCSC "Load and Resistance Factor Design Specification for Structural Joints Using ASTM A325 or A490 Bolts."  
<sup>b</sup>Tabulated values are for the case of load application transverse to the slot. When the load is parallel to the slot, multiply tabulated values by 0.85.

In standard or short-slotted holes,

$$R_n = 2.4 dtF_u \tag{J3-1a}$$

In long-slotted holes perpendicular to the load,

$$R_n = 2.0 dtF_u \tag{J3-1b}$$

For the bolt closest to the edge, in all connections not covered by Formulas J3- 1a and J3-1b, the design bearing of a single bolt, or two or more bolts in line of force, each with an end distance less than  $1\frac{1}{2}d$ , shall be determined by  $\phi R_n$ , where  $\phi = 0.75$ .

$$R_n = LtF_u \quad (J3-1c)$$

If deformation around the bolt hole is not a design consideration and adequate spacing and edge distance as required by Sections J3.9 and J3.10 is provided, the following formula may be used in lieu of Formulas J3-1a and J3-1b, where  $\phi = 0.75$ .

$$R_n = 3.0 dtF_u \quad (J3-1d)$$

**WHERE:**

- $d$  = nominal dia. of bolt, in. (mm)
- $F_u$  = specified tensile strength of connected part, ksi (N/mm<sup>2</sup>)
- $L$  = distance in line of force from the center of a standard or oversized hole or from the center of the end of a slotted hole to an edge of a connected part, in. (mm)
- $t$  = thickness of connected part, in. (mm)

**7. Size and Use of Holes.**

a. The *maximum sizes* of holes for rivets and bolts are given in Table J3.5, except that larger holes, required for tolerance on location of anchor bolts in concrete foundations, may be used in column base details.

**TABLE J3.5**  
**Nominal Hole Dimensions**

Bolt Diameter	Hole Dimensions			
	Standard (Diameter)	Oversize (Diameter)	Shot-slot (Width × length)	Long-slot (Width × length)
(× 25.4 for mm)				
1/2	9/16	5/8	9/16 × 11/16	9/16 × 11/4
5/8	11/16	13/16	11/16 × 7/8	11/16 × 15/16
3/4	13/16	15/16	13/16 × 1	13/16 × 17/8
7/8	15/16	11/8	15/16 × 11/8	15/16 × 23/16
1	11/16	11/4	11/16 × 15/16	11/16 × 21/2
≥ 11/8	$d + 1/16$	$d + 5/16$	$(d + 1/16) × (d + 3/8)$	$(d + 1/16) × (2.5 × d)$

b. *Standard holes* shall be provided in member-to-member connections, unless oversized, short-slotted or long-slotted holes in bolted connections are approved by the designer. Finger shims up to 1/4 inch (6 mm) may be introduced into slip-critical connections designed on the basis of standard holes without reducing the nominal shear strength of the fastener to that specified for slotted holes.

c. *Oversized holes* may be used in any or all plies of slip-critical connections, but they shall not be used in bearing-type connections. Hardened washers shall be installed over oversized holes in an outer ply.

d. *Short-slotted holes* may be used in any or all plies of slip-critical or bearing-type connections. The slots may be used without regard to direction of loading in slip-critical connections, but the length shall be normal to the direction of the load in bearing-type connections. Washers shall be installed over short-slotted holes in an outer ply; when high-strength bolts are used, such washers shall be hardened.

e. *Long-slotted holes* may be used in only one of the connected parts of either a slip-critical or bearing-type connection at an individual faying surface. Long-slotted holes may be used without regard to direction of loading in slip-critical connections, but shall be normal to the direction of load in bearing-type connections. Where long-slotted holes are used in an outer ply, plate washers or a continuous bar with standard holes, having a size sufficient to completely cover the slot after instal-

lation, shall be provided. In high-strength bolted connections, such plate washers or continuous bars shall not be less than  $5/16$ -inch (7.9 mm) thick and shall be of structural grade material, but need not be hardened. If hardened washers are required for use of high-strength bolts, the hardened washers shall be placed over the outer surface of the plate washer or bar.

f. When A490 bolts over 1 inch (25 mm) in diameter are used in slotted or oversized holes in external plies, a single hardened washer conforming to F436, except with  $5/16$ -inch (7.9 mm) minimum thickness, shall be used in lieu of the standard washer.

**8. Long Grips.** A307 bolts providing design strength, and for which the grip exceeds five diameters, shall have their number increased 1 percent for each additional  $1/16$  inch (1.6 mm) in the grip.

**TABLE J3.6**  
Values of Spacing Increment  $C_1$ , in.

Nominal Diameter of Fastener	Oversized Holes	Slotted Holes		
		Perpendicular to Line of Force	Parallel to Line of Force	
			Short-slots	Long-slots <sup>a</sup>
× 25.4 for mm				
≤ $7/8$	$1/8$	0	$3/16$	$1\frac{1}{2}d - 1/16$
1	$3/16$	0	$1/4$	$1\frac{1}{2}d - 1/16$
≥ $1\frac{1}{8}$	$1/4$	0	$5/16$	$1\frac{1}{2}d - 1/16$

<sup>a</sup>When length of slot is less than maximum allowed in Table J3.5,  $C_1$  may be reduced by the difference between the maximum and actual slot lengths.

**9. Minimum Spacing.** The distance between centers of standard, oversized or slotted fastener holes shall not be less than three times the nominal diameter of the fastener, or less than that required by the following paragraph, if applicable.

Along a line of transmitted forces, the distance between centers of holes shall not be less than  $3d$  when  $R_n$  is determined by J3-1a and J3-1b. Otherwise the distance between centers of holes shall not be less than the following:

a. For standard holes:

$$\frac{P}{\phi F_u t} + \frac{d_h}{2} \tag{J3-2}$$

**WHERE:**

$d_h$  = diameter of standard size hole, in. (mm)

$F_u$  = specified minimum tensile strength of the critical connected part, ksi (N/mm<sup>2</sup>)

$P$  = force transmitted by one fastener to the critical connected part, kips (N)

$t$  = thickness of the critical connected part, in. (mm)

$\phi$  = 0.75

b. For oversized and slotted holes, the distance required for standard holes in Subparagraph a, above, plus the applicable increment  $C_1$  from Table J3.6, but the clear distance between holes shall not be less than one bolt diameter.

**10. Minimum Edge Distance.** The distance from the center of a standard hole to an edge of a connected part shall not be less than the applicable value from Table J3.7 or the value from Formula J3-3, as applicable.

Along a line of transmitted force, in the direction of the force, the distance from the center of a standard hole to the edge of the connected part shall not be less than  $1\frac{1}{2}d$  when  $R_n$  is determined by Formulas J3-1a or J3-1b. Otherwise the edge distance shall not be less than

$$\frac{P}{\phi F_u t} \quad (J3-3)$$

where  $\phi$ ,  $P$ ,  $F_u$ ,  $t$  are defined in Section J3.9.

**TABLE J3.7**  
**Minimum Edge Distance, in.**  
(Center of Standard Hole<sup>a</sup> to Edge of Connected Part)

Nominal Rivet or Bolt Diameter (in.)	At Sheared Edges	At Rolled Edges of Plates, Shapes or Bars of Gas Cut Edges <sup>b</sup>
× 25.4 for mm		
1/2	7/8	3/4
5/8	1 1/8	7/8
3/4	1 1/4	1
7/8	1 1/2 <sup>c</sup>	1 1/3
1	1 3/4 <sup>c</sup>	1 1/4
1 1/8	2	1 1/2
1 1/4	2 1/4	1 5/8
Over 1 1/4	1 3/4 × Diameter	1 1/4 × Diameter
<sup>a</sup> For oversized or slotted holes, see Table J3.8. <sup>b</sup> All edge distances in this column may be reduced 1/8-in. (3 mm) when the hole is at a point where stress does not exceed 25% of the maximum design strength in the element. <sup>c</sup> These may be 1 1/4 in. (32 mm) at the ends of beam connection angles.		

The distance from the center of an oversized or slotted hole to an edge of a connected part shall not be less than that required for a standard hole plus the applicable increment,  $C_2$ , from Table J3.8.

**11. Maximum Edge Distance and Spacing.** The maximum distance from the center of any rivet or bolt to the nearest edge of parts in contact shall be 12 times the thickness of the connected part under consideration, but shall not exceed 6 inches (152 mm). Bolted joints in unpainted steel exposed to atmospheric corrosion require special limitations on pitch and edge distance. See Section E4.

**J4. DESIGN SHEAR RUPTURE STRENGTH**

The design strength for the limit state of rupture along a shear failure path in main members shall be taken as  $\phi F_n A_{ns}$ .

**WHERE:**

$$\begin{aligned} A_{ns} &= \text{net area subject to shear.} \\ F_n &= 0.6 F_u \\ \phi &= 0.75 \end{aligned} \quad (J4-1)$$

**J5. CONNECTING ELEMENTS**

This section applies to the design of connecting elements, such as stiffeners, gussets, angles and brackets and the panel zones of beam-to-column connections.

**1. Eccentric Connections.** Intersecting axially stressed members shall have their gravity axes intersect at one point, if practical; if not, provision shall be made for bending and shearing stresses due to the eccentricity.

**TABLE J3.8**  
Values of Edge Distance Increment  $C_2$ , in.

Nominal Diameter of Fastener (in.)	Oversized Holes	Slotted Holes		
		Perpendicular to Edge		Parallel to Edge
		Short Slots	Long Slots <sup>a</sup>	
× 25.4 for mm				
≤ 7/8	1/16	1/8	$3/4d$	0
1	1/8	1/8		
≤ 1 1/8	1/8	3/16		

<sup>a</sup>When length of slot is less than maximum allowable (see Table J3.5),  $C_2$  may be reduced by one-half the difference between the maximum and actual slot lengths.

**2. Design Strength of Connecting Elements.** The design strength  $\phi R_n$  of welded, bolted and riveted connecting elements statically loaded in tension (e.g., splice and gusset plates) shall be the lower value obtained according to the limit states of yielding, fracture of the connecting element and block shear rupture.

- a. For yielding of the connecting element:

$$\begin{aligned} \phi &= 0.90 \\ R_n &= A_g F_y \end{aligned} \tag{J5-1}$$

- b. For fracture of the connecting element where  $A_n \leq 0.85 A_g$ :

$$\begin{aligned} \phi &= 0.75 \\ R_n &= A_n F_u \end{aligned} \tag{J5-2}$$

- c. For block shear rupture: Block shear is a failure mode in which the resistance is determined by the sum of the shear strength on a failure path(s) and the tensile strength on a perpendicular segment. When ultimate strength on the net section is used to determine the resistance on one segment, yielding on the gross section shall be used on the perpendicular segment:  $\phi = 0.75$ . Design strength shall be the larger of the two failure modes.

At beam end connections where the top flange is coped, and in similar situations, failure can occur by shear along a plane through the fasteners, acting in combination with tension along a perpendicular plane. In such cases, the ultimate strength on the net section (shear or tension) shall be used to determine the resistance of one segment and yielding on the gross section (shear or tension) shall be used for the perpendicular segment, with  $\phi = 0.75$  for both. By alternating the choice of which segment resistance is based on ultimate strength, two possible values of design strength are obtained. The larger value shall be taken as the design strength.

For all other connecting elements, the design strength  $\phi R_n$  shall be determined for the applicable limit state to insure that the design strength is equal to or greater than the required strength, where  $R_n$  is the nominal strength appropriate to the geometry and type of loading on the connecting element. The shear limit state is governed by:

$$\begin{aligned} \phi &= 0.80 \\ R_n &= 0.7A_g F_y \end{aligned} \tag{J5-3}$$

**J6. FILLERS**

In welded construction, any filler 1/4 inch (6.4 mm) or more in thickness shall extend beyond the edges of the splice plate and shall be welded to the part on which it is fitted with sufficient weld to transmit the splice plate load, applied at the surface of the filler. The welds joining the splice plate to the filler shall be sufficient to transmit the splice plate load and shall be long enough to avoid over-

loading the filler along the toe of the weld. Any filler less than 1/4-inch (6.4 mm) thick shall have its edges made flush with the edges of the splice plate and the weld size shall be the sum of the size necessary to carry the splice plus the thickness of the filler plate.

When bolts or rivets carrying loads pass through fillers thicker than 1/4 inch, except in connections designed as slip-critical connections, the fillers shall be extended beyond the splice material and the filler extension shall be secured by enough bolts or rivets to distribute the total stress in the member uniformly over the combined section of the member and the filler, or an equivalent number of fasteners shall be included in the connection.

**J7. SPLICES**

Groove-welded splices in plate girders and beams shall develop the full strength of the smaller spliced section. Other types of splices in cross sections of plate girders and beams shall develop the strength required by the forces at the point of splice.

**J8. BEARING STRENGTH**

The strength of surfaces in bearing is  $\phi R_n$ , where  $\phi = 0.75$  and  $R_n$  is defined below for various types of bearing.

**1. Milled or Finished Surfaces.** For milled surfaces, pins in reamed, drilled or bored holes, and ends of fitted bearing stiffeners,

$$R_n = 2.0 F_y A_{pb} \tag{J8-1}$$

**WHERE:**

- $A_{pb}$  = projected bearing area, in.<sup>2</sup> (mm<sup>2</sup>)
- $F_y$  = specified minimum yield stress, ksi (N/mm<sup>2</sup>)

**2. Expansion Rollers and Rockers.** For expansion rollers and rockers,

$$R_n = 1.5 (F_y - 13) ld/20 \tag{J8-2}$$

For SI:  $R_n = 1.5 (F_y - 90) ld/20$

**WHERE:**

- $d$  = diameter, in. (mm)
- $l$  = length of bearing, in. (mm)

**J9. COLUMN BASES AND BEARING ON CONCRETE**

Proper provision shall be made to transfer the column loads and moments to the footings and foundations.

In the absence of code regulations, design bearing loads on concrete may be taken as  $\phi_c P_p$ :

On the full area of a concrete support . . . . .  $P_p = 0.85f'_c A_1$

On less than the full area of a concrete support . . . . .  $P_p = 0.85f'_c A_1 \sqrt{A_2/A_1}$

**WHERE:**

- $A_1$  = area of steel concentrically bearing on a concrete support, in. (mm<sup>2</sup>)
- $A_2$  = maximum area of the portion of the supporting surface that is geometrically similar to and concentric with the loaded area, in.<sup>2</sup> (mm<sup>2</sup>)
- $\phi_c = 0.60$
- $\sqrt{A_2/A_1} \leq 2$

**J10. ANCHOR BOLTS AND EMBEDMENTS**

**1. Anchor Bolts.** Anchor bolts shall be designed to provide resistance to all design conditions on completed structures of tension and shear at the bases of columns, including the net tensile components of any bending moment which may result from column base restraint.

**2. Embedments.** The concrete structure shall be designed to safely support the loads from the embedment with an appropriate factor of safety to ensure that the embedment strength is not reduced as a result of local or gross failure of the supporting concrete structure.

The strength and design of the structural steel elements of the embedment shall be in accordance with this specification. Bolts, studs and bars functioning as embedment anchors resisting tensile loads shall be designed to transfer the design load to the concrete by means of bond, shear, bearing or a combination thereof.

Shear loads shall be considered to be transmitted by the embedment to the concrete by either shear lugs or shear friction.

The friction force  $V$ , kips (N), to resist shear shall be computed as follows:

$$V = \mu P \quad (\text{J10-1})$$

**WHERE:**

$P$  = normal force, kips (N)

$\mu$  = coefficient of friction

The coefficient of friction,  $\mu$ , shall be 0.90 for concrete placed against as-rolled steel with contact plane a full plate thickness below the concrete surface; 0.70 for concrete or grout placed against as-rolled steel with contact plane coincidental with the concrete surface; 0.55 for grouted conditions with the contact plane between grout and as-rolled steel above the concrete surface.

**3. Prestressed Embedments.** Anchorage to concrete structures by means of post-tensioned high-strength steel members is permissible. The material and the design requirements of the high-strength steel members and associated anchorage, as well as the fabrication and installation procedures, shall conform to the appropriate provisions of applicable codes.

## CHAPTER K

### STRENGTH DESIGN CONSIDERATIONS

This chapter covers additional member strength design considerations related to introduction of concentrated forces, ponding, torsion and fatigue.

#### K1. WEBS AND FLANGES WITH CONCENTRATED FORCES

**1. Design Basis.** Members with concentrated loads applied normal to *one flange* and symmetric to the web shall have a flange and web design strength sufficient to satisfy the local flange bending, web yielding strength, web crippling and side-sway web buckling criteria of Sections K1.2, K1.3, K1.4 and K1.5. Members with concentrated loads applied to *both flanges* shall have a web design strength sufficient to satisfy the web yielding, web crippling and column web buckling criteria of Sections K1.3, K1.4 and K1.6.

Where pairs of stiffeners are provided on opposite sides of the web, at concentrated loads, and extend at least half the depth of the member, Sections K1.2 and K1.3 need not be checked.

For column webs subject to high shears, see Section K1.7; for bearing stiffeners, see Section K1.8.

**2. Local Flange Bending.** The flange design strength in bending due to a tensile load shall be  $\phi R_n$ , kips (N).

**WHERE:**

$F_{yf}$  = specified minimum yield stress of flange, ksi (N/mm<sup>2</sup>)

$$R_n = 6.25t_f^2 F_{yf} \quad (\text{K1-1})$$

$t_f$  = thickness of the loaded flange, in. (mm)

$\phi$  = 0.90

If the length of loading measured across the member flange is less than  $0.15b$ , where  $b$  is the member flange width, Formula (K1-1) need not be checked.

**3. Local Web Yielding.** The design strength of the web at the toe of the fillet under concentrated loads shall be  $\phi R_n$ , kips (N), where  $\phi = 1.0$  and  $R_n$  is determined as follows:

- a. When the force to be resisted is a concentrated load producing tension or compression, applied at a distance from the member end that is greater than the depth of the member,

$$R_n = (5k + N) F_{yw} t_w \quad (\text{K1-2})$$

- b. When the force to be resisted is a concentrated load applied at or near the end of the member,

$$R_n = (2.5k + N) F_{yw} t_w \quad (\text{K1-3})$$

**WHERE:**

$F_{yw}$  = specified minimum yield stress of the web, ksi (N/mm<sup>2</sup>)

$k$  = distance from outer face of flange to web toe of fillet, in. (mm)

$N$  = length of bearing, in. (mm)

$t_w$  = web thickness, in. (mm)

**4. Web Crippling.** For unstiffened portions of webs of members under concentrated loads, the design compressive strength shall be  $\phi R_n$ , kips, where  $\phi = 0.75$  and the nominal strength,  $R_n$ , is determined as follows:

- a. When the concentrated load is applied at a distance not less than  $d/2$  from the end of the member:

$$R_n = 135t_w^2 \left[ 1 + 3 \left( \frac{N}{d} \right) \left( \frac{t_w}{t_f} \right)^{1.5} \right] \sqrt{F_{yw} t_f / t_w} \quad (\text{K1-4})$$

For SI: 
$$R_n = 0.80t_w^2 \left[ 1 + 3 \left( \frac{N}{d} \right) \left( \frac{t_w}{t_f} \right)^{1.5} \right] \sqrt{EF_{yw} (t_f / t_w)}$$

- b. When the concentrated load is applied less than a distance  $d/2$  from the end of the member:

$$R_n = 68t_w^2 \left[ 1 + 3 \left( \frac{N}{d} \right) \left( \frac{t_w}{t_f} \right)^{1.5} \right] \sqrt{F_{yw} t_f / t_w} \quad (\text{K1-5})$$

For SI: 
$$R_n = 0.40t_w^2 \left[ 1 + 3 \left( \frac{N}{d} \right) \left( \frac{t_w}{t_f} \right)^{1.5} \right] \sqrt{EF_{yw} (t_f / t_w)}$$

**WHERE:**

$d$  = overall depth of the member, in. (mm)

$t_f$  = flange thickness, in. (mm)

If stiffeners are provided and extend at least one-half the web depth, Formulas (K1-4) and (K1-5) need not be checked.

**5. Sidesway Web Buckling.** For webs of members with flanges not restrained against relative movement by stiffeners or lateral bracing and subject to concentrated compressive loads, the design compressive strength shall be  $\phi R_n$ , kips (N), where  $\phi = 0.85$  and the nominal strength,  $R_n$ , shall be determined as follows:

- a. If the loaded flange is restrained against rotation and  $(d_c/t_w)/(\rho/b_f)$  is less than 2.3:

$$R_n = \frac{12,000t_w^3}{h} \left[ 1 + 0.4 \left( \frac{d_c/t_w}{l/b_f} \right)^3 \right] \quad (\text{K1-6})$$

For SI:

$$R_n = \frac{0.40Et_w^3}{h} \left[ 1 + 0.4 \left( \frac{d_c/t_w}{l/b_f} \right)^3 \right]$$

b. If the loaded flange is *not* restrained against rotation and  $(d_c/t_w)/(l/b_f)$  is less than 1.7:

$$R_n = \frac{12,000t_w^3}{h} \left[ 0.4 \left( \frac{d_c/t_w}{l/b_f} \right)^3 \right] \quad (\text{K1-7})$$

For SI:

$$R_n = \frac{0.40Et_w^3}{h} \left[ 0.4 \left( \frac{d_c/t_w}{l/b_f} \right)^3 \right]$$

**WHERE:**

$b_f$  = flange width, in. (mm)

$d_c$  =  $d - 2k$  = web depth clear of fillets, in. (mm)

$l$  = largest laterally unbraced length along either flange at the point of load, in. (mm)

$t_w$  = web thickness, in. (mm)

Formulas (K1-6) and (K1-7) need not be checked providing  $(d_c/t_w)/(l/b_f)$  exceeds 2.3 or 1.7, respectively, or for webs subject to distributed load.

If a concentrated load is located at a point where the web flexural stress due to factored load is below yielding, 24,000 (0.8E) may be used in lieu of 12,000 (0.40E) in Formulas (K1-6) and (K1-7).

**6. Compression Buckling of the Web.** For unstiffened portions of webs of members under concentrated loads to both flanges, the design compressive strength shall be  $\phi R_n$ , kips (N), where

$$\phi = 0.90$$

$$R_n = \frac{4,100t_w^3 \sqrt{F_{yw}}}{d_c} \quad (\text{K1-8})$$

For SI:

$$R_n = \frac{24t_w^3 \sqrt{EF_{yw}}}{d_c}$$

$R_n$  may be exceeded provided that a transverse stiffener or pair of stiffeners is attached to the web to satisfy Section F3.

**7. Compression Members with Web Panels Subject to High Shear.** For compression members subject to high shear stress in the web, the design web shear strength shall be  $\phi R_v$ , kips (N), where  $\phi = 0.90$  and  $R_v$  shall be determined as follows:

a. For  $P_u \leq 0.75 P_n$ :

$$R_v = 0.7 F_y d_c t_w \quad (\text{K1-9})$$

b. For  $P_u > 0.75 P_n$ :

$$R_v = 0.7 F_y d_c t_w [1.9 - 1.2 (P_u/P_n)] \quad (\text{K1-10})$$

**WHERE:**

$P_n$  = nominal axial strength, kips (N)

$P_u$  = required axial strength, kips (N)

**8. Stiffener Requirements for Concentrated Loads.** When required, stiffeners shall be placed in pairs at unframed ends of beams and girders. They shall be placed in pairs at points of concentrated load on the interior of beams, girders or columns if the load exceeds the nominal strength,  $\phi R_n$ , as determined from Sections K1.2 through K1.6, as applicable.

If the concentrated load, tension or compression exceeds the criteria for  $\phi R_n$  of Section K1.2 or K1.3, respectively, stiffeners need not extend more than one half the depth of the web, except as follows:

If concentrated compressive loads are applied to the members and if the load exceeds the compressive strength of the web  $\phi R_n$  given in Section K1.4 or K1.6, the stiffeners shall be designed as axially compressed members (columns) in accordance with requirements of Section E2 with an effective length equal to  $0.75h$ , a cross section composed of two stiffeners and a strip of the web having a width of  $25t_w$ , at interior stiffeners and  $12t_w$  at the ends of members.

When the load normal to the flange is tensile, the stiffeners shall be welded to the loaded flange. When the load normal to the flange is compressive, the stiffeners shall either bear on or be welded to the loaded flange.

**K2. PONDING**

The roof system shall be investigated by structural analysis to assure adequate strength and stability under ponding conditions, unless the roof surface is provided with sufficient slope toward points of free drainage or adequate individual drains to prevent the accumulation of rainwater.

The roof system shall be considered stable and no further investigation is needed if:

$$C_p + 0.9C_s \leq 0.25 \quad (\text{K2-1})$$

$$\text{and } I_d \geq 25 (S^4) 10^{-6} \quad [\text{For SI: } I_d \geq 12.1 (S^4) 10^{-10}] \quad (\text{H2-2})$$

**WHERE:**

$$C_p = \frac{32L_s L_p^4}{10^7 I_p} \quad \text{For SI: } \frac{\gamma L_s L_p^4}{\pi^4 E I_p}$$

$$C_s = \frac{32S L_s^4}{10^7 I_s} \quad \text{For SI: } \frac{\gamma S L_s^4}{\pi^4 E I_s}$$

$I_d$  = moment of inertia of the steel deck supported on secondary members, in.<sup>4</sup> per ft. (mm<sup>4</sup> per mm)

$I_p$  = moment of inertia of primary members, in.<sup>4</sup> (mm<sup>4</sup>)

$I_s$  = moment of inertia of secondary members, in.<sup>4</sup> (mm<sup>4</sup>)

$L_p$  = column spacing in direction of girder (length of primary members), ft. (mm)

$L_s$  = column spacing perpendicular to direction of girder (length of secondary members), ft. (mm)

$S$  = spacing of secondary members, ft. (mm)

$\gamma$  = the unit mass of water in kg/mm<sup>3</sup> times the acceleration of gravity in mm/s<sup>2</sup>,  $9.81 \times 10^{-6}$  N/mm<sup>2</sup>.

For trusses and steel joists, the moment of inertia,  $I_s$ , shall be decreased 15 percent when used in the above equation. A steel deck shall be considered a secondary member when it is directly supported by the primary members.

See Appendix K2 for an alternate determination of flat roof framing stiffness.

**K3. TORSION**

For limiting values of normal and shear stress, due to torsion and other loading, see Section H2. Some constrained local yielding may be permitted.

**K4. FATIGUE**

Few members or connections in conventional buildings need to be designed for fatigue, since most load changes in such structures occur only a small number of times or produce only minor stress fluctuations. The occurrence of full design wind or earthquake loads is too infrequent to warrant consideration in fatigue design. However, crane runways and supporting structures for machinery and equipment are often subject to fatigue loading conditions.

Members and their connections subject to fatigue loading shall be proportioned in accordance with the provisions of Appendix K4 for service loads.

**CHAPTER L****SERVICEABILITY DESIGN CONSIDERATIONS**

This chapter is intended to provide design guidance for serviceability considerations not covered elsewhere. Serviceability is a state in which the function of a building, its appearance, maintainability, durability and comfort of its occupants are preserved under normal usage.

The general design requirement for serviceability is given in Section A5.4. Limiting values of structural behavior to ensure serviceability (e.g., maximum deflections, accelerations, etc.) shall be chosen with due regard to the intended function of the structure.

Where necessary, serviceability shall be checked using realistic loads for the appropriate serviceability limit state.

**L1. CAMBER**

If any special camber requirements are necessary to bring a loaded member into proper relation with the work of other trades, as for the attachment of runs of sash, the requirements shall be set forth in the design documents.

Beams and trusses detailed without specified camber shall be fabricated so that after erection any camber due to rolling or shop assembly shall be upward. If camber involves the erection of any member under a preload, this shall be noted in the design documents.

**L2. EXPANSION AND CONTRACTION**

Adequate provision shall be made for expansion and contraction appropriate to the service conditions of the structure.

**L3. DEFLECTIONS, VIBRATION AND DRIFT**

**1. Deflections.** Deformations in structural members and structural systems due to service loads shall not impair the serviceability of the structure.

**2. Vibration.** Vibration shall be considered in designing beams and girders supporting large areas free of partitions or other sources of damping, where vibration due to pedestrian traffic or other sources within the building might not be acceptable.

**3. Drift.** Lateral deflection or drift of structures due to code-specified wind or seismic loads shall not cause collision with adjacent structures or exceed the limiting values of such drifts which may be specified or appropriate.

#### L4. CONNECTION SLIP

For the design of slip-resistant connections, see Section J3.5.

#### L5. CORROSION

When appropriate, structural components shall be designed to tolerate corrosion or shall be protected against corrosion that may impair the strength or serviceability of the structure.

### CHAPTER M

#### FABRICATION, ERECTION AND QUALITY CONTROL

##### M1. SHOP DRAWINGS

Shop drawings giving complete information necessary for the fabrication of the component parts of the structure, including the location, type and size of all welds, bolts and rivets, shall be prepared in advance of the actual fabrication. These drawings shall clearly distinguish between shop and field welds and bolts and shall clearly identify slip-critical, high-strength bolted connections.

Shop drawings shall be made in conformity with the best practice and with due regard to speed and economy in fabrication and erection.

##### M2. FABRICATION

**1. Cambering, Curving and Straightening.** Local application of heat or mechanical means may be used to introduce or correct camber, curvature and straightness. The temperature of heated areas, as measured by approved methods, shall not exceed 1,100°F. (593°C.) for A514 (A514M) steel nor 1,200°F. (649°C.) for other steels.

**2. Thermal Cutting.** Thermal cutting shall preferably be done by machine. Thermally cut edges which will be subjected to substantial stress, or which are to have weld metal deposited on them, shall be reasonably free from notches or gouges; notches or gouges not more than  $\frac{3}{16}$  inch (4.8 mm) deep will be permitted. Notches or gouges greater than  $\frac{3}{16}$  inch (4.8 mm) deep that remain from cutting shall be removed by grinding or repaired by welding. All reentrant corners shall be shaped to provide a smooth transition. If a specific contour is required, it must be shown in the design documents.

##### M2.2 THERMAL CUTTING

Thermally cut free edges which will be subject to substantial tensile stress shall be free of gouges greater than  $\frac{3}{16}$  inch (4.8 mm) deep and sharp notches; gouges greater than  $\frac{3}{16}$  inch (4.8 mm) deep and sharp notches shall be removed by grinding or repaired by welding. Thermally cut edges which are to have weld deposited upon them shall be reasonably free of notches or gouges.

All reentrant corners shall be shaped to a smooth transition. If specific contour is required it must be shown on the contract documents.

Beam copes and weld access holes shall meet the geometrical requirements of Section J1.11. For beam copes and weld access holes in ASTM A6 Groups 4 and 5 shapes and welding built-up shapes with material thickness greater than 2 inches (51 mm), a preheat temperature of not less than 150°F. (65.6°C.) shall be applied prior to thermal cutting.

**3. Planing of Edges.** Planing or finishing of sheared or thermally cut edges of plates or shapes will not be required unless specifically called for in the design documents or included in a stipulated edge preparation for welding.

**4. Welding Construction.** The technique of welding, the workmanship, appearance and quality of welds and the methods used in correcting nonconforming work shall be in accordance with Section 3, Workmanship, and Section 4, Technique, of the *AWS Structural Welding Code—Steel*, D1.1.

**5. Bolted Construction.** All parts of bolted members shall be pinned or bolted and rigidly held together while assembling. Use of a drift pin in bolt holes during assembling shall not distort the metal or enlarge the holes. Poor matching of holes shall be cause for rejection.

If the thickness of the material is not greater than the nominal diameter of the bolt plus  $\frac{1}{8}$  inch (3.2 mm), the holes may be punched. If the thickness of the material is greater than the nominal diameter of the bolt plus  $\frac{1}{8}$  inch (3.2 mm), the holes shall be either drilled or subpunched and reamed. The die for all subpunched holes, and the drill for all subdrilled holes, shall be at least  $\frac{1}{16}$  inch (1.6 mm) smaller than the nominal diameter of the bolt. Holes in A514 steel plates over  $\frac{1}{2}$  inch (13 mm) thick shall be drilled.

Fully inserted finger shims, with a total thickness of not more than  $\frac{1}{4}$  inch (6.4 mm) within a joint, may be used in joints without changing the design load (based upon hole type) for the design of connections. The orientation of such shims is independent of the direction of application of the load.

The use of high-strength bolts shall conform to the requirements of the RCSC Load and Resistance Factor Design Specification for Structural Joints Using ASTM A325 or A490 Bolts.

**6. Compression Joints.** Compression joints which depend on contact bearing as part of the splice capacity shall have the bearing surfaces of individual fabricated pieces prepared by milling, sawing or other suitable means.

**7. Dimensional Tolerances.** Dimensional tolerances shall be as permitted in the *Code of Standard Practice* of the American Institute of Steel Construction, Inc., 1986 edition.

**8. Finishing of Column Bases.** Column bases and base plates shall be finished in accordance with the following requirements:

- a. Steel bearing plates 2 inches (51 mm) or less in thickness may be used without milling, provided a satisfactory contact bearing is obtained. Steel bearing plates over 2 inches (51 mm) but not over 4 inches (102 mm) in thickness may be straightened by pressing or, if presses are not available, by milling for all bearing surfaces (except as noted in subparagraphs b and c of this section), to obtain a satisfactory contact bearing. Steel bearing plates over 4 inches (102 mm) in thickness shall be milled for all bearing surfaces (except as noted in subparagraphs b and c of this section).
- b. Bottom surfaces of bearing plates and column bases which are grouted to ensure full bearing contact on foundations need not be milled.
- c. Top surfaces of bearing plates need not be milled when full-penetration welds are provided between the column and the bearing plate.

### M3. SHOP PAINTING

**1. General Requirements.** Shop painting and surface preparation shall be in accordance with the provisions of the *Code of Standard Practice* of the American Institute of Steel Construction, Inc., 1986 edition.

Unless otherwise specified, steelwork which will be concealed by interior building finish or will be in contact with concrete need not be painted. Unless specifically excluded, all other steelwork shall be given one coat of shop paint.

**2. Inaccessible Surfaces.** Except for contact surfaces, surfaces inaccessible after shop assembly shall be cleaned and painted prior to assembly, if required by the design documents.

**3. Contact Surfaces.** Paint is permitted unconditionally in bearing-type connections. For slip-critical connections where the design is based on special faying surface conditions in accordance with Section J3.5, shop contact surfaces shall be cleaned prior to assembly in accordance with the provisions of the *Code of Standard Practice* of the American Institute of Steel Construction, Inc., 1986 edition, but shall not be painted. Field contact surfaces and surfaces meeting the requirements of Section J3.5 shall be shop cleaned in accordance with the design documents, except as provided by Section M3.5.

**4. Finished Surfaces.** Machine-finished surfaces shall be protected against corrosion by a rust-inhibiting coating that can be removed prior to erection, or which has characteristics that make removal prior to erection unnecessary.

**5. Surfaces Adjacent to Field Welds.** Unless otherwise specified in the design documents, surfaces within 2 inches (51 mm) of any field weld location shall be free of materials that would prevent proper welding or produce toxic fumes during welding.

#### M4. ERECTION

**1. Alignment of Column Bases.** Column bases shall be set level and to correct elevation with full bearing on concrete or masonry.

**2. Bracing.** The frame of steel skeleton buildings shall be carried up true and plumb within the limits defined in the *Code of Standard Practice* of the American Institute of Steel Construction, Inc., 1986 edition. Temporary bracing shall be provided, in accordance with the requirements of the *Code of Standard Practice*, wherever necessary to take care of all loads to which the structure may be subjected, including equipment and the operation of same. Such bracing shall be left in place as long as may be required for safety.

**3. Alignment.** No permanent bolting or welding shall be performed until as much of the structure as will be stiffened thereby has been properly aligned.

**4. Fit of Column Compression Joints.** Lack of contact bearing not exceeding a gap of  $1/16$  inch (1.6 mm), regardless of the type of splice used (partial-penetration groove welded or bolted), shall be acceptable. If the gap exceeds  $1/16$  inch (1.6 mm), and if an engineering investigation shows that sufficient contact area does not exist, the gap shall be packed out with nontapered steel shims. Shims need not be other than mild steel, regardless of the grade of the main material.

**5. Field Welding.** Any shop paint on surfaces adjacent to joints to be field welded shall be wire brushed to reduce the paint film to a minimum.

Field welding of attachments to installed embedments in contact with concrete shall be done in such a manner as to avoid excessive thermal expansion of the embedment which could result in spalling or cracking of the concrete or excessive stress in the embedment anchors.

**6. Field Painting.** Responsibility for touch-up painting, cleaning and field painting shall be allocated in accordance with accepted local practices, and this allocation shall be set forth explicitly in the design documents.

**7. Field Connections.** As erection progresses, the work shall be securely bolted or welded to take care of all dead load, wind and erection stresses.

#### M5. QUALITY CONTROL

The fabricator shall provide quality control procedures to the extent that he deems necessary to assure that all work is performed in accordance with this Specification. In addition to the fabricator's quality control procedures, material and workmanship at all times may be subject to inspection by qualified inspectors representing the purchaser. If such inspection by representatives of the purchaser will be required, it shall be so stated in the design documents.

**1. Cooperation.** As far as possible, all inspection by representatives of the purchaser shall be made at the fabricator's plant. The fabricator shall cooperate with the inspector, permitting access for in-

spection to all places where work is being done. The purchaser's inspector shall schedule his work for minimum interruption to the work of the fabricator.

**2. Rejections.** Material or workmanship not in reasonable conformance with the provisions of this Specification may be rejected at any time during the progress of the work. The fabricator shall receive copies of all reports furnished to the purchaser by the inspection agency.

**3. Inspection of Welding.** The inspection of welding shall be performed in accordance with Section 6 of the *AWS Structural Welding Code—Steel*, D1.1.

When visual inspection is required to be performed by AWS certified welding inspectors, it shall be so specified in the design documents.

When nondestructive testing is required, the process, extent and standards of acceptance shall be clearly defined in the design documents.

**4. Inspection of Slip-critical, High-strength Bolted Connections.** The inspection of slip-critical, high-strength bolted connections shall be in accordance with the provisions of the RCSC Load and Resistance Factor Design Specification for Structural Joints Using ASTM A325 or A490 Bolts.

**5. Identification of Steel.** The fabricator shall be able to demonstrate by a written procedure and by actual practice, a method of material application and identification visible at least through the "fit-up" operation of the main structural elements of a shipping piece.

The identification method shall be capable of verifying proper material application as it relates to:

1. Material specification designation.
2. Heat number, if required.
3. Material test reports for special requirements.

## APPENDIX B

### DESIGN REQUIREMENTS

#### B5. LOCAL BUCKLING

**3. Slender Compression Elements.** Axially loaded members containing elements subject to compression which have a width-thickness ratio in excess of the applicable  $\lambda_r$ , as stipulated in Section B5.1, shall be proportioned according to this Appendix. Flexural members with slender compression elements shall be designed in accordance with Appendix F1.7. Rolled flexural members with proportions not covered by Appendix F1.7 shall be designed in accordance with this Appendix.

**a. Unstiffened Compression Elements.** The design strength of unstiffened compression elements whose width-thickness ratio exceeds the applicable limit  $\lambda_r$ , as stipulated in Section B5.1, shall be subject to a reduction factor  $Q_s$ . The value of  $Q_s$  shall be determined by Formulas (A-B5-1) through (A-B5-6), as applicable. When such elements comprise the compression flange of a flexural member, the maximum required bending stress shall not exceed  $\phi_b F_y Q_s$ , where  $\phi_b = 0.90$ . The design strength of axially loaded compression members shall be modified by the appropriate reduction factor,  $Q_s$ , as provided in paragraph c.

For single angles:

When  $76.0/\sqrt{F_y} < b/t < 155/\sqrt{F_y}$ :

$$Q_s = 1.340 - 0.00447 (b/t)\sqrt{F_y} \quad (\text{A-B5-1})$$

For SI: When  $0.45\sqrt{E/F_y} < b/t < 0.91\sqrt{E/F_y}$ :

$$Q_s = 1.340 - 0.76 (b/t)\sqrt{F_y/E}$$

When  $b/t \geq 155/\sqrt{F_y}$ :

$$Q_s = 15,500/[F_y(b/t)^2] \quad (\text{A-B5-2})$$

For SI: When  $b/t \geq 0.91\sqrt{F_y}$ :

$$Q_s = 0.53E/[F_y(b/t)^2]$$

For angles or plates projecting from columns or other compression members, and for projecting elements of compression flanges of girders:

When  $95.0/\sqrt{F_y} < b/t < 176/\sqrt{F_y}$ :

$$Q_s = 1.415 - 0.00437 (b/t)\sqrt{F_y} \quad (\text{A-B5-3})$$

For SI: When  $0.56\sqrt{E/F_y} < b/t < 1.03\sqrt{E/F_y}$ :

$$Q_s = 1.415 - 0.74 (b/t)\sqrt{F_y/E}$$

When  $b/t \geq 176/\sqrt{F_y}$ :

$$Q_s = 20,000/[F_y(b/t)^2] \quad (\text{A-B5-4})$$

For SI: When  $b/t \geq 1.03\sqrt{E/F_y}$ :

$$Q_s = 0.69E/[F_y(b/t)^2]$$

For stems of tees:

When  $127/\sqrt{F_y} < b/t < 176/\sqrt{F_y}$ :

$$Q_s = 1.908 - 0.00715 (b/t)\sqrt{F_y} \quad (\text{A-B5-5})$$

For SI: When  $0.75\sqrt{E/F_y} < b/t < 1.03\sqrt{E/F_y}$ :

$$Q_s = 1.908 - 1.22 (b/t)\sqrt{F_y/E}$$

When  $b/t \geq 176/\sqrt{f_y}$ :

$$Q_s = 20,000/[F_y(b/t)^2] \quad (\text{A-B5-6})$$

For SI: When  $b/t \geq 1.03\sqrt{E/f_y}$ :

$$Q_s = 0.69E/[F_y(b/t)^2]$$

**WHERE:**

$b$  = width of unstiffened compression element as defined in Section B5.1, in. (mm)

$F_y$  = specified minimum yield stress, ksi (N/mm<sup>2</sup>)

$t$  = thickness of unstiffened element, in. (mm)

Unstiffened elements of tees whose proportions exceed the limits of Section B5.1 shall conform to the limits given in Table A-B5.1.

**b. Stiffened Compression Elements.** When the width-thickness ratio of uniformly compressed stiffened elements (except perforated cover plates) exceeds the limit  $\lambda_r$  stipulated in Section B5.1, a reduced effective width,  $b_e$ , shall be used in computing the design properties of the section containing the element.

TABLE A-B5.1  
Limiting Proportions for Tees

Shape	Ratio of Full Flange Width to Profile Depth	Ratio of Flange Thickness to Web or Stem Thickness
Built-up tees	$\geq 0.50$	$\geq 1.25$
Rolled tees	$\geq 0.50$	$\geq 1.10$

i. For flanges of square and rectangular sections of uniform thickness:

$$b_e = \frac{326t}{\sqrt{f}} \left[ 1 - \frac{64.9}{(b/t)\sqrt{f}} \right] \leq b \quad (\text{A-B5-7})$$

For SI: 
$$b_e = 1.91t \sqrt{\frac{E}{f}} \left[ 1 - \frac{0.38}{(b/t)\sqrt{f}} \sqrt{\frac{E}{f}} \right] \leq b$$

ii. For other uniformly compressed elements:

$$b_e = \frac{326t}{\sqrt{f}} \left[ 1 - \frac{57.2}{(b/t)\sqrt{f}} \right] \leq b \quad (\text{A-B5-8})$$

For SI: 
$$b_e = 1.91t \sqrt{\frac{E}{f}} \left[ 1 - \frac{0.34}{(b/t)\sqrt{f}} \sqrt{\frac{E}{f}} \right] \leq b$$

**WHERE :**

$b$  = actual width of a stiffened compression element, as defined in Section B5.1, in. (mm)

$b_e$  = reduced width, in. (mm)

$f$  = computed elastic compressive stress in the stiffened elements, based on the design properties as specified in Section C of this Appendix, ksi (N/mm<sup>2</sup>). If unstiffened elements are included in the total cross section,  $f$  for the stiffened element must be such that the maximum compressive stress in the unstiffened element does not exceed  $\phi F_{cr}$  as defined in Appendix B5.3c with  $Q = Q_s$  and  $\phi_c = 0.85$ , or  $\phi_b F_y Q_s$  with  $\phi_b = 0.90$ , as applicable.

$t$  = element thickness, in.

iii. For axially loaded circular sections:

Members with diameter-to-thickness ratios,  $D/t$ , greater than  $3,300/F_y$  (For SI:  $0.11E/F_y$ ), but having a diameter-to-thickness ratio of less than  $13,000/F_y$  (For SI:  $0.47E/F_y$ );

$$Q = \frac{1,100}{F_y(D/t)} + \frac{2}{3} \quad (\text{A-B5-9})$$

For SI: 
$$Q = \frac{0.038E}{F_y(D/t)} + \frac{2}{3}$$

**WHERE:**

$D$  = outside diameter, in. (mm)

$t$  = wall thickness, in. (mm)

**c. Design Properties.** Properties of sections shall be determined using the full cross section, except as follows:

In computing the moment of inertia and elastic section modulus of flexural members, the effective width of uniformly compressed stiffened elements, as determined in Appendix B5.3b, shall be used in determining effective cross-sectional properties.

For unstiffened elements of the cross section,  $Q_s$  is determined from Appendix B5.3a. For stiffened elements of the cross section:

$$Q_a = \frac{\text{effective area}}{\text{actual area}} \quad (\text{A-B5-10})$$

where the effective area is equal to the summation of the effective areas of the cross section.

For axially loaded compression members, the gross cross-sectional area and the radius of gyration,  $r$ , shall be computed on the basis of the actual cross section. However, when  $\lambda_c \sqrt{Q} \leq 1.5$ , the critical stress,  $F_{cr}$ , shall be determined by

$$F_{cr} = Q(0.658^{Q\lambda_c^2})F_y \quad (\text{A-B5-11})$$

**WHERE:**

$$Q = Q_s Q_a \quad (\text{A-B5-12})$$

i. Cross sections composed entirely of unstiffened elements,  $Q = Q_s (Q_a = 1.0)$

ii. Cross sections composed entirely of stiffened elements,  $Q = Q_a (Q_s = 1.0)$

iii. Cross sections composed of both stiffened and unstiffened elements,  $Q = Q_s Q_a$

When  $\lambda_c \sqrt{Q} > 1.5$ , the critical stress,  $F_{cr}$ , shall be determined by

$$F_{cr} = \left[ \frac{0.877}{\lambda_c^2} \right] F_y \quad (\text{A-B5-13})$$

## APPENDIX E

### COLUMNS AND OTHER COMPRESSION MEMBERS

#### E3. FLEXURAL-TORSIONAL BUCKLING

This section applies to the strength of singly symmetric and unsymmetric columns for the limiting states of flexural-torsional and torsional buckling.

Torsional buckling of symmetric shapes and flexural-torsional buckling of unsymmetric shapes are modes of buckling usually not considered in the design of hot-rolled columns. (Generally, either these modes do not govern or the critical load differs very little from the weak-axis planar buckling load.) Such buckling modes may, however, control the capacity of columns made from relatively thin plate elements and of unsymmetric columns.

The strength of compression members determined by the limit states of torsional and flexural-torsional buckling is  $\phi_c P_n$ .

**WHERE:**

$A_g$  = gross area of cross section, in.<sup>2</sup> (mm<sup>2</sup>)

- $P_n$  = nominal resistance in compression, kips (N)  
 $= A_g F_{cr}$  (A-E3-1)  
 $Q$  = 1.0 for elements meeting the width-thickness ratios,  $\lambda_r$ , of Section B5.1  
 $= Q_s Q_a$  for elements not meeting the width-thickness ratios  $\lambda_r$  of Section B5.1 and determined in accordance with the provisions of Appendix B5.3  
 $\phi$  = 0.85

The nominal critical stress,  $F_{cr}$ , is determined as follows:

- a. For  $\lambda_e \sqrt{Q} \leq 1.5$ :

$$F_{cr} = Q(0.658^{2\lambda_e^2})F_y \quad (\text{A-E3-2})$$

- b. For  $\lambda_e \sqrt{Q} > 1.5$ :

$$F_{cr} = \left[ \frac{0.877}{\lambda_e^2} \right] F_y \quad (\text{A-E3-3})$$

**WHERE:**

$$\lambda_e = \sqrt{F_y/F_e} \quad (\text{A-E3-4})$$

$F_y$  = specified minimum yield stress of steel, ksi (N/mm<sup>2</sup>)

The critical torsional or flexural-torsional elastic buckling stress,  $F_e$ , is determined as follows:

- a. For doubly symmetric shapes, the critical torsional elastic buckling stress is

$$F_e = \left[ \frac{\pi^2 E C_w}{(K_z L)^2} + GJ \right] \frac{1}{I_x + I_y} \quad (\text{A-E3-5})$$

- b. For singly symmetric shapes, where  $y$  is the axis of symmetry, the critical flexural-torsional elastic buckling stress is

$$F_e = \frac{F_{ey} + F_{ez}}{2H} \left( 1 - \sqrt{1 - \frac{4F_{ey} F_{ez} H}{(F_{ey} + F_{ez})^2}} \right) \quad (\text{A-E3-6})$$

- c. For unsymmetric shapes, the critical flexural-torsional elastic buckling stress,  $F_e$ , is the lowest root of the cubic equation

$$\begin{aligned}
 &(F_e - F_{ex})(F_e - F_{ey})(F_e - F_{ez}) - \\
 &F_e^2(F_e - F_{ey})(x_o/\bar{r}_o)^2 - \\
 &F_e^2(F_e - F_{ex})(y_o/\bar{r}_o)^2 = 0
 \end{aligned} \quad (\text{A-E3-7})$$

**WHERE:**

- $C$  = warping constant, in.<sup>6</sup> (mm<sup>6</sup>)  
 $E$  = modulus of elasticity, ksi (N/mm<sup>2</sup>)  
 $G$  = shear modulus, ksi (N/mm<sup>2</sup>)  
 $I_x, I_y$  = moment of inertia about the principal axes, in.<sup>4</sup> (mm<sup>4</sup>)  
 $J$  = torsional constant, in.<sup>4</sup> (mm<sup>4</sup>)  
 $K_z$  = effective length factor for torsional buckling  
 $x_o, y_o$  = coordinates of shear center with respect to the centroid, in. (mm)

$$\bar{r}_o^2 = x_o^2 + y_o^2 + \frac{I_x + I_y}{A} \quad (\text{A-E3-8})$$

$$H = 1 - \left( \frac{x_o^2 + y_o^2}{r_o^2} \right) \quad (\text{A-E3-9})$$

$$F_{ex} = \frac{\pi^2 E}{(K_x L/r_x)^2} \quad (\text{A-E3-10})$$

$$F_{ey} = \frac{\pi^2 E}{(K_y L/r_y)^2} \quad (\text{A-E3-11})$$

$$F_{ex} = \left( \frac{\pi^2 E C_w}{(K_z L)^2} + GJ \right) \frac{1}{A r_o^2} \quad (\text{A-E3-12})$$

**WHERE:**

- $A$  = cross-sectional area of member, in.<sup>2</sup> (mm<sup>2</sup>)
- $K_x, K_y$  = effective length factors in  $x$  and  $y$  directions
- $L$  = unbraced length, in. (mm)
- $r_x, r_y$  = radii of gyration about the principal axes, in. (mm)

**APPENDIX F**

**BEAMS AND OTHER FLEXURAL MEMBERS**

**F1. DESIGN FOR FLEXURE**

**7. Nominal Flexural Strength.** Table A-F1. 1 provides a tabular summary of Formulas (F1-3) through (F1-16) for determining the nominal flexural strength of beams and girders. For slenderness parameters of cross sections not included in Table A-F1. 1, see Appendix B5.3.

The nominal flexural strength,  $M_n$ , is the lowest value obtained according to the limit states of: (a) lateral-torsional buckling (LTB); (b) flange local buckling (FLB); and (c) web local buckling (WLB).

The nominal flexural strength,  $M_n$ , shall be determined as follows for each limit state:

For  $\lambda \leq \lambda_p$ :

$$M_n = M_p \quad (\text{A-F1-1})$$

For  $\lambda_p < \lambda \leq \lambda_r$ :

For the limit state of lateral-torsional buckling:

$$M_n = C_b \left[ M_p - (M_p - M_r) \left( \frac{\lambda - \lambda_p}{\lambda_r - \lambda_p} \right) \right] \leq M_p \quad (\text{A-F1-2})$$

For the limit states of flange and web local buckling:

$$M_n = M_p - (M_p - M_r) \left( \frac{\lambda - \lambda_p}{\lambda_r - \lambda_p} \right) \quad (\text{A-F1-3})$$

For  $\lambda > \lambda_r$ :

For the limit state of lateral-torsional buckling and for flange local buckling:

$$M_n = M_{cr} = S F_{cr} \quad (\text{A-F1-4})$$

For  $\lambda$  of the flange  $>\lambda_r$  in shapes not included in Table A-F1.1, see Appendix B5.3.

For  $\lambda$  of the web  $>\lambda_r$ , see Appendix G.

For all slenderness parameters, the flexural strength of hybrid sections is limited by the flexural strength of equivalent homogeneous sections made up of the hybrid web and flange steel grade.

The terms used in the above equations are:

$C_b = 1.75 + 1.05(M_1/M_2) + 0.3(M_1/M_2)^2 \leq 2.3$  where  $M_1$  is the smaller and  $M_2$  the larger end-moment in the unbraced segment of the beam;  $M_1/M_2$  is positive when the moments cause reverse curvature.

$F_{cr}$  = critical stress, ksi (N/mm<sup>2</sup>)

$L_b$  = laterally unbraced length, in. (mm)

$M_{cr}$  = buckling moment, kip-in. (N·mm)

$M_n$  = nominal flexural strength, kip-in. (N·mm)

$M_p$  = plastic moment, kip-in. (N·mm)

$M_r$  = limiting buckling moment (equal to  $M_{cr}$  when  $\lambda = \lambda_r$ ), kip-in. (N·mm)

$S$  = section modulus, in.<sup>3</sup> (mm<sup>3</sup>)

$r_y$  = radius of gyration about minor axis, in. (mm)

$\lambda$  = controlling slenderness parameter

= minor axis slenderness ratio,  $L_b/r_y$ , for lateral-torsional buckling

= flange width-thickness ratio,  $b/t$ , for flange local buckling as defined in Section B5.1

= web depth-thickness ratio,  $h/t_w$ , for web local buckling as defined in Section B5.1

$\lambda_p$  = largest value of  $\lambda$  for which  $M_n = M_p$

$\lambda_r$  = largest value of  $\lambda$  for which buckling is inelastic

The applicable limit states and equations for  $M_p$ ,  $M_n$ ,  $F_{cr}$ ,  $\lambda$ ,  $\lambda_p$  and  $\lambda_r$  are given in Table A-F1.1 for the shapes covered in this Appendix. The terms used in the table are:

$A$  = cross-sectional area, in.<sup>2</sup> (mm<sup>2</sup>)

$b$  = flange width, in. (mm)

$d$  = overall depth, in. (mm)

$F_r$  = compressive residual stress in flange

= 10 ksi (70 N/mm<sup>2</sup>) for rolled shapes

= 16.5 ksi (115 N/mm<sup>2</sup>) for welded shapes

$F_y$  = specified minimum yield strength, ksi (N/mm<sup>2</sup>)

$F_{yf}$  = yield strength of the flange, ksi (N/mm<sup>2</sup>)

$F_{yw}$  = yield strength of the web, ksi (N/mm<sup>2</sup>)

$h_c$  = twice the distance from the neutral axis to the inside face of the compression flange less the fillet or corner radius, in. (mm)

$J$  = torsional constant, in.<sup>4</sup> (mm<sup>4</sup>)

$R_e$  = see Appendix G2

$(S_x)_{eff}$  = effective section modulus about major axis, in.<sup>3</sup> (mm<sup>3</sup>)

$S_{xc}$  = section modulus of the outside fiber of the compression flange, in.<sup>3</sup> (mm<sup>3</sup>)

$S_{xt}$  = section modulus of the outside fiber of the tension flange, in.<sup>3</sup> (mm<sup>3</sup>)

$t_f$  = flange thickness, in. (mm)

$t_w$  = web thickness, in. (mm)

$Z$  = plastic section modulus, in.<sup>3</sup> (mm<sup>3</sup>)

TABLE A-F1.1  
Nominal Strength Parameters

Shape	Plastic Moment, $M_p$	Limit State of Buckling	Limiting Buckling Moment, $M_r$	
Channels and doubly and singly symmetric I-shaped beams (including hybrid beams) bent about major axis	$F_y Z_x$ (e)	LTB doubly symmetric members and channels	$(\bar{r}_{yw} - F_r) S_x$	
		LTB singly symmetric members	$(F_{yw} - F_r) S_{xc} \leq F_{yt} S_{xt}$	
		FLB	$(\bar{r}_{yw} - F_r) S_x$	
		WLB	$R_e F_{yt} S_x$	
Channels and doubly symmetric I-shaped members bent about minor axis	$F_y Z_y$	FLB	$F_y S_y$	
Solid symmetric shapes, except rectangular bars, bent about major axis	$F_y Z_x$	Not Applicable		
Solid rectangular bars bent about major axis	$F_y Z_x$	LTB	$F_y S_x$	
Critical Stress, $F_{cr}$	Slenderness Parameters			Limitations
	$\lambda$	$\lambda_p$	$\lambda_r$	
$\frac{C_b X_1 \sqrt{2}}{\lambda} \sqrt{1 + \frac{X_1^2 X_2}{2\lambda^2}}$ (b)	$\frac{L_b}{r_y}$	$\frac{300}{\sqrt{F_{yt}}}$	(a, b)	1. Applicable for I-shaped members $h_c/t_w \leq 970/\sqrt{F_{yt}}$ when $h_c/t_w > 970/\sqrt{F_{yt}}$ See Appendix G 2. When $\lambda > \lambda_r$ a) Applicable for built-up channels if $b/d \leq 0.25$ and $t_f/t_w \leq 3.0$ b) Applicable for rolled channels if $b/d \leq 0.25$ and $t_f/t_w \leq 2.0$
(c)	$\frac{L_b}{r_y}$	$\frac{300}{\sqrt{F_{yt}}}$	Value of $\lambda$ for which $M_{cr} = S_{xc} (F_{yt} - F_r)$	
(g)	$\frac{b}{t}$	$\frac{65}{\sqrt{F_{yt}}}$	(h)	
N.A.	$\frac{h_c}{t_w}$	$\frac{640}{\sqrt{F_{yt}}}$	$\frac{970}{\sqrt{F_{yt}}}$	
Same as for major axis				
Not Applicable				
$\frac{57,000 C_b \sqrt{JA}}{S_x}$	$\frac{L_b}{r_y}$	$\frac{3,750 \sqrt{JA}}{M_p}$	$\frac{57,000 \sqrt{JA}}{M_r}$	

TABLE A-F1.1 (continued)  
Nominal Strength Parameters

Shape	Plastic Moment, $M_p$	Limit State of Buckling	Limiting Buckling Moment, $M_r$
Symmetric box sections loaded in a plane of symmetry	$F_y Z_x$	LTB	$(F_{yt} - F_r) S_x$
		FLB	$F_y S_x$
		WLB	Same as for I-shape
Circular tubes	$F_y Z$	LTB	Not applicable
		FLB	$M_n = \left( \frac{600}{D/t} + F_y \right) S^{(n)}$
		WLB	Not applicable
<p>a <math>\lambda_r = \frac{X_1}{(F_{yw} - F_r)} \sqrt{1 + \sqrt{1 + X_2(F_{yw} - F_r)^2}}</math></p> <p>b <math>X_1 = \frac{\pi}{S_x} \sqrt{\frac{EGJA}{2}}</math> <math>X_2 = 4 \frac{C_w}{I_y} \left( \frac{S_x}{GJ} \right)^2</math></p> <p>c <math>M_{cr} = \frac{57,000 C_b}{L_b} \sqrt{I_y J} (B_1 + \sqrt{1 + B_2 + B_1^2}) \leq S_{xt} F_y</math></p> <p>where</p> $B_1 = 2.25 [2(I_{yc}/I_y) - 1](h/L_b) \sqrt{I_y/J}$ $B_2 = 25(1 - I_{yc}/I_y)(I_{yc}/J)(h/L_b)^2$ <p>If the compression flange is larger than the tension flange, <math>M_{cr}</math> may be evaluated conservatively by the formula for doubly symmetric members, using for <math>X_1</math> and <math>X_2</math> the values for a symmetric section both of whose flanges are the same as the compression flange of the singly symmetric section.</p>			

TABLE A-F1.1 (continued)  
Nominal Strength Parameters

Critical Stress, $F_{cr}$	Slenderness Parameters			Limitations
	$\lambda$	$\lambda_p$	$\lambda_r$	
$\frac{57,000 C_b \sqrt{JA}}{\lambda S_x}$	$\frac{L_b}{r_y}$	$\frac{3,750 \sqrt{JA}}{M_p}$	$\frac{57,000 \sqrt{JA}}{M_r}$	Applicable if $\frac{h_c/t_w}{\sqrt{F_{yt}}} \leq 970$
$\frac{(S_x)_{eff}}{S_x} F_y^{(d)}$	$\frac{b}{t}$	$\frac{190}{F_y}$	$\frac{238}{\sqrt{(F_y - F_r)}}$	LTB applies only if $d > b$
Same as for I-shape				
Not applicable				
$\frac{9,750}{D/t}$	$D/t$	$\frac{2,070}{F_y}$	$\frac{8,970}{F_y}$	$D/t < \frac{13,000}{F_y}$
Not applicable				
<sup>d</sup> $(S_x)_{eff}$ is the section modulus for a section with a compression-flange width, $b_e$ , given $b_e = \frac{326t}{\sqrt{f}} \left( 1 - \frac{64.9}{(b/t)\sqrt{f}} \right)$ for flanges of square and rectangular series of uniform thickness <sup>e</sup> Computed from fully plastic stress distribution for hybrid sections. <sup>f</sup> This equation is to be used in place of Formula A-F1-3. <sup>g</sup> $F_{cr} = \frac{20,000}{\lambda^2}$ for rolled shapes $F_{cr} = \frac{11,200}{\lambda^2}$ for welded shapes <sup>h</sup> $\lambda_r = \frac{141}{\sqrt{F_{yw} - 10}}$ for rolled shapes $\lambda_r = \frac{106}{\sqrt{F_{yw} - 16.5}}$ for welded shapes				

NOTE: See next page for metric conversions.

For SI:

**TABLE A-F1.1**  
**Nominal Strength Parameters**

Shape	Plastic Moment, $M_p$	Limit State of Buckling	Limiting Buckling Moment, $M_r$	
Channels and doubly and singly symmetric I-shaped beams (including hybrid beams) bent about major axis	$F_y Z_x$ (e)	LTB doubly symmetric members and channels	$(F_{yw} - F_r) S_x$	
		LTB singly symmetric members	$(F_{yw} - F_r) S_{xc} \leq F_{yt} S_{xt}$	
		FLB	$(F_{yw} - F_r) S_x$	
		WLB	$R_e F_{yt} S_x$	
Channels and doubly symmetric I-shaped members bent about minor axis	$F_y Z_y$	FLB	$F_y S_y$	
Solid symmetric shapes, except rectangular bars, bent about major axis	$F_y Z_x$	Not Applicable		
Solid rectangular bars bent about major axis	$F_y Z_x$	LTB	$F_y S_x$	
Critical Stress, $F_{cr}$	Slenderness Parameters			Limitations
	$\lambda$	$\lambda_p$	$\lambda_r$	
$\frac{C_b X_1 \sqrt{2}}{\lambda} \sqrt{1 + \frac{X_1^2 X_2}{2\lambda^2}}$ (b)	$\frac{L_b}{r_y}$	$1.76 \sqrt{\frac{E}{F_{yt}}}$	(a, b)	1. Applicable for I-shaped members $h_c/t_w \leq 5.70 \sqrt{E/F_{yt}}$ when $h_c/t_w > 5.70 \sqrt{E/F_{yt}}$ See Appendix G 2. When $\lambda > \lambda_r$ a) Applicable for built-up channels if $b/d \leq 0.25$ and $t_f/t_w \leq 3.0$ b) Applicable for rolled channels if $b/d \leq 0.25$ and $t_f/t_w \leq 2.0$
(c)	$\frac{L_b}{r_y}$	$1.76 \sqrt{\frac{E}{F_{yt}}}$	Value of $\lambda$ for which $M_{cr} = S_{xc} (F_{yt} - F_r)$	
(g)	$\frac{b}{t}$	$0.38 \sqrt{\frac{E}{F_{yt}}}$	(h)	
N.A.	$\frac{h_c}{t_w}$	$3.76 \sqrt{\frac{E}{F_{yt}}}$	$5.70 \sqrt{\frac{E}{F_{yt}}}$	
Same as for major axis				
Not Applicable				
$\frac{2EC_b \sqrt{JA}}{S_x}$	$\frac{L_b}{r_y}$	$\frac{0.13E \sqrt{JA}}{M_p}$	$\frac{2E \sqrt{JA}}{M_r}$	

TABLE A-F1.1 (continued)  
Nominal Strength Parameters

Shape	Plastic Moment, $M_p$	Limit State of Buckling	Limiting Buckling Moment, $M_r$
Symmetric box sections loaded in a plane of symmetry	$F_y Z_x$	LTB	$(F_{yt} - F_t) S_x$
		FLB	$F_y S_x$
		WLB	Same as for I-shape
Circular tubes	$F_y Z$	LTB	Not applicable
		FLB	$M_n = \left( \frac{0.021E}{D/t} + F_y \right) S$
		WLB	Not applicable
<p>a <math>\lambda_r = \frac{X_1}{(F_{yw} - F_t)} \sqrt{1 + \sqrt{1 + X_2(F_{yw} - F_t)^2}}</math></p> <p>b <math>X_1 = \frac{\pi}{S_x} \sqrt{\frac{EGJA}{2}}</math>    <math>X_2 = 4 \frac{C_w}{I_y} \left( \frac{S_x}{GJ} \right)^2</math></p> <p>c <math>M_{cr} = \frac{2EC_b}{L_b} \sqrt{I_y J} (B_1 + \sqrt{1 + B_2 + B_1^2}) \leq S_x F_y</math></p> <p>where</p> $B_1 = 2.25 [2(I_{yc}/I_y) - 1](h/L_b) \sqrt{(I_y/J)} \quad B_2 = 25(1 - I_{yc}/I_y)(I_{yc}/J)(h/L_b)^2$ <p>If the compression flange is larger than the tension flange, <math>M_{cr}</math> may be evaluated conservatively by the formula for doubly symmetric members, using for <math>X_1</math> and <math>X_2</math> the values for a symmetric section both of whose flanges are the same as the compression flange of the singly symmetric section.</p>			

TABLE A-F1.1 (continued)  
Nominal Strength Parameters

Critical Stress, $F_{cr}$	Slenderness Parameters			Limitations
	$\lambda$	$\lambda_p$	$\lambda_r$	
$\frac{2EC_b\sqrt{JA}}{S_x}$	$\frac{L_b}{r_y}$	$\frac{0.13E\sqrt{JA}}{M_p}$	$\frac{2E\sqrt{JA}}{M_r}$	Ap- plies if $\leq 5.70 \sqrt{\frac{E}{F_{yf}}}$ ca- ble if
$\frac{(S_x)_{eff} F_y}{S_x}$	$\frac{b}{t}$	$\frac{0.0066E}{F_y}$	$1.40 \sqrt{\frac{E}{(F_y - F_r)}}$	LTB applies only if $d > b$
Same as for I-shape				
Not applicable				
$\frac{0.34E}{D/t}$	$D/t$	$0.071 \frac{E}{F_y}$	$\frac{0.31E}{F_y}$	$D/t < \frac{0.45E}{F_y}$
Not applicable				
<sup>d</sup> $(S_x)_{eff}$ is the section modulus for a section with a compression-flange width, $b_e$ , given $b_e = 1.91t \sqrt{\frac{E}{t}} \left[ 1 - \frac{0.38}{(b/t)} \sqrt{\frac{E}{f}} \right]$ for flanges of square and rectangular series of uniform thickness <sup>e</sup> Computed from fully plastic stress distribution for hybrid sections. <sup>f</sup> This equation is to be used in place of Formula A-F1-3. <sup>g</sup> $F_{cr} = \frac{0.69E}{\lambda^2}$ for rolled shapes $F_{cr} = \frac{0.39E}{\lambda^2}$ for welded shapes <sup>h</sup> $\lambda_r = 0.83 \sqrt{\frac{E}{F_{yw} - 70}}$ for rolled shapes $\lambda_r = 0.62 \sqrt{\frac{E}{F_{yw} - 115}}$ for welded shapes				

#### F4. WEB-TAPERED MEMBERS

The design of tapered members meeting the requirements of this section shall be governed by the provisions of Chapter F, except as modified by this Appendix.

**1. General Requirements.** In order to qualify under this Specification, a tapered member must meet the following requirements:

- a. It shall possess at least one axis of symmetry which shall be perpendicular to the plane of bending if moments are present.
- b. The flanges shall be of equal and constant area.
- c. The depth shall vary linearly as

$$d = d_o \left( 1 + \gamma \frac{z}{L} \right) \quad (\text{A-F4-1})$$

**WHERE:**

- $d_o$  = depth at smaller end of member, in. (mm)
- $d_L$  = depth at larger end of member, in. (mm)
- $L$  = unbraced length of member measured between the center of gravity of the bracing members, in. (mm)
- $z$  = distance from the smaller end of member, in. (mm)
- $\gamma = (d_L - d_o)/d_o \leq$  the smaller of  $0.268(L/d_o)$  or  $6.0$

**2. Design Tensile Strength.** The design strength of tapered tension members shall be determined in accordance with Section D1.

**3. Design Compressive Strength.** The design strength of tapered compression members shall be determined in accordance with Section E2, using an effective slenderness parameter  $\lambda_{eff}$  computed as follows:

$$\lambda_{eff} = \frac{S}{\pi} \sqrt{\frac{QF_y}{E}} \quad (\text{A-F4-2})$$

**WHERE:**

- $E$  = modulus of elasticity for steel, ksi (N/mm<sup>2</sup>)
- $F_y$  = specified minimum yield stress, ksi (N/mm<sup>2</sup>)
- $K$  = effective length factor for a prismatic member
- $K\gamma$  = effective length factor for a tapered member as determined by a rational analysis
- $Q$  = reduction factor
  - = 1.0 if all elements meet the limiting width-thickness ratios,  $\lambda_r$ , of Section B5.1
  - =  $Q_s Q_u$ , determined in accordance with Appendix B, if any stiffened and/or unstiffened elements exceed the ratios,  $\lambda_r$ , of Section B5.1
- $r_{ox}$  = strong axis radius of gyration at the smaller end of a tapered member, in. (mm)
- $r_{oy}$  = weak axis radius of gyration at the smaller end of a tapered member, in. (mm)
- $S = KL/r_{oy}$  for weak axis bending and  $K\gamma L/r_{ox}$  for strong axis bending

The smallest area of the tapered member shall be used for  $A_g$  in Formula (E2-1).

**4. Design Flexural Strength.** The design flexural strength of tapered flexural members for the limit state of lateral-torsional buckling is  $\phi_b M_n$ , where  $\phi_b = 0.90$  and the nominal strength is

$$M_n = (5/3)S'_x F_{by} \quad (\text{A-F4-3})$$

**WHERE:**

- $S'_x$  = the section modulus of the critical section of the unbraced beam length under consideration

$$F_{by} = \frac{2}{3} \left[ 1.0 - \frac{F_y}{6B \sqrt{F_{sy}^2 + F_{wy}^2}} \right] F_y \leq 0.60F_y \quad (\text{A-F4-4})$$

unless  $F_b \gamma \leq F_y/3$ , in which case

$$F_{by} = B \sqrt{F_{sy}^2 + F_{wy}^2} \quad (\text{A-F4-5})$$

In the above equations,

$$F_{sy} = \frac{12 \times 10^3}{h_s L d_o / A_f} \quad (\text{A-F4-6})$$

For SI: 
$$F_{sy} = \frac{0.41E}{h_s L d_o / A_f}$$

$$F_{wy} = \frac{170 \times 10^3}{(h_w L / r_{T0})^2} \quad (\text{A-F4-7})$$

For SI: 
$$F_{wy} = \frac{5.9E}{(h_w L / r_{T0})^2}$$

**WHERE:**

$A_f$  = area of the compression flange, in.<sup>2</sup> (mm<sup>2</sup>)

$h_s$  = factor equal to  $1.0 + 0.0230\gamma \sqrt{L d_o / A_f}$

$h_w$  = factor equal to  $1.0 + 0.00385 \gamma \sqrt{L / r_{T0}}$

$r_{T0}$  = radius of gyration of a section at the smaller end, considering only the compression flange plus one third of the compression web area, taken about an axis in the plane of the web, in. (mm)

and where  $B$  is determined as follows:

- a. When the maximum moment,  $M_2$ , in three adjacent segments of approximately equal unbraced length is located within the central segment and  $M_1$  is the larger moment at one end of the three-segment portion of a member:\*

$$B = 1.0 + 0.37 \left( 1.0 + \frac{M_1}{M_2} \right) + 0.50\gamma \left( 1.0 + \frac{M_1}{M_2} \right) \geq 1.0 \quad (\text{A-F4-8})$$

- b. When the largest computed bending stress,  $f_{b2}$ , occurs at the larger end of two adjacent segments of approximately equal unbraced lengths and  $f_{b1}$  is the computed bending stress at the smaller end of the two-segment portion of a member:\*\*

$$B = 1.0 + 0.58 \left( 1.0 + \frac{f_{b1}}{f_{b2}} \right) - 0.70\gamma \left( 1.0 + \frac{f_{b1}}{f_{b2}} \right) \geq 1.0 \quad (\text{A-F4-9})$$

\* $M_1/M_2$  is considered as negative when producing single curvature. In the rare case where  $M_1/M_2$  is positive, it is recommended that it be taken as zero.

\*\* $f_{b1}/f_{b2}$  is considered as negative when producing single curvature. If a point of contraflexure occurs in one of two adjacent unbraced segments,  $f_{b1}/f_{b2}$  is considered as positive. The ratio  $f_{b1}/f_{b2} \neq 0$ .

- c. When the largest computed bending stress,  $f_{b2}$ , occurs at the smaller end of two adjacent segments of approximately equal unbraced length and  $f_{b1}$  is the computed bending stress at the larger end of the two-segment portion of a member:\*

$$B = 1.0 + 0.55 \left( 1.0 + \frac{f_{b1}}{f_{b2}} \right) + 2.20\gamma \left( 1.0 + \frac{f_{b1}}{f_{b2}} \right) \geq 1.0 \quad (\text{A-F4-10})$$

In the foregoing,  $\gamma = (d_L - d_o)/d_o$  is calculated for the unbraced length that contains the maximum computed bending stress.

- d. When the computed bending stress at the smaller end of a tapered member or segment thereof is equal to zero:

$$B = \frac{1.75}{1.0 + 0.25 \sqrt{\gamma}} \quad (\text{A-F4-11})$$

where  $\gamma = (d_L - d_o)/d_o$  calculated for the unbraced length adjacent to the point of zero bending stress.

**5. Design Shear Strength.** The design shear strength of tapered flexural members shall be determined in accordance with Section F2.

**6. Combined Flexure and Axial Force.** For tapered members with a single web taper subject to compression and bending about the major axis, Formulas (H1-1) through (H1-3) apply, with the following modifications:  $P_n$  and  $P_{ex}$  shall be determined for the properties of the smaller end, using appropriate effective length factors.  $M_{nx}$ ,  $M_u$  and  $M_{px}$  shall be determined for the larger end;  $M_{nx} = (5/3)S'_x F_b \gamma$ , where  $S'_x$  is the elastic section modulus of the larger end, and  $F_b \gamma$  is the design flexural stress of tapered members.  $C_{mx}$  is replaced by  $C'_m$ , determined as follows:

- a. When the member is subjected to end moments which cause single curvature bending and approximately equal computed moments at the ends:

$$C'_m = 1.0 + 0.1 \left( \frac{P_u}{\phi_b P_{ex}} \right) + 0.3 \left( \frac{P_u}{\phi_b P_{ex}} \right)^2 \quad (\text{A-F4-12})$$

- b. When the computed bending moment at the smaller end of the unbraced length is equal to zero:

$$C'_m = 1.0 + 0.9 \left( \frac{P_u}{\phi_b P_{ex}} \right) + 0.6 \left( \frac{P_u}{\phi_b P_{ex}} \right)^2 \quad (\text{A-F4-13})$$

When the effective slenderness parameter  $\lambda_{eff} \geq 1.0$  and combined stress is checked incrementally along the length, the actual area and the actual section modulus at the section under investigation may be used.

## APPENDIX G

### PLATE GIRDERS

#### G1. LIMITATIONS

Doubly and singly symmetric single-web nonhybrid and hybrid plate girders loaded in the plane of the web may be proportioned according to the provisions of this Appendix or Section F2, provided that these limits are satisfied.

- a. For  $\frac{a}{h} \leq 1.5$ :

---

\* $f_{b1}/f_{b2}$  is considered as negative when producing single curvature. If a point of contraflexure occurs in one of two adjacent unbraced segments,  $f_{b1}/f_{b2}$  is considered as positive. The ratio  $f_{b1}/f_{b2} \neq 0$ .

$$\frac{h}{t_w} \max = \frac{2,000}{\sqrt{F_{yf}}} \quad (\text{A-G1-1})$$

For SI: 
$$\frac{h}{t_w} \max = 11.74 \sqrt{\frac{E}{F_{yf}}}$$

b. For  $\frac{a}{h} > 1.5$ :

$$\frac{h}{t_w} \max = \frac{14,000}{\sqrt{F_{yf}(F_{yf} + 16.5)}} \quad (\text{A-G1-2})$$

For SI: 
$$\frac{h}{t_w} \max = \frac{0.48E}{\sqrt{F_{yf}(F_{yf} + F_r)}}$$

**WHERE:**

$a$  = clear distance between transverse stiffeners, in. (mm)

$F_{yf}$  = specified minimum yield stress of the flange, ksi (N/mm<sup>2</sup>)

$h$  = clear distance between flanges less the fillet or corner radius for rolled shapes; and for built-up sections, the distance between adjacent lines of fasteners or the clear distance between flanges when welds are used, in. (mm)

$t_w$  = web thickness, in. (mm)

In unstiffened girders,  $h/t_w$  must be less than 260.

**G2. DESIGN FLEXURAL STRENGTH**

The design flexural strength for plate girders with slender webs ( $h_c/t_w > 970/\sqrt{F_{yf}}$ ) (For SI:  $h_c/t_w > 5.70\sqrt{E/F_y}$ ) shall be  $\phi_b M_n$ , where  $\phi_b = 0.90$  and  $M_n$  is the lower value obtained according to the limit states of tension-flange yield and compression-flange buckling. When  $h_c/t_w > 970/\sqrt{F_{yf}}$  (For SI:  $h_c/t_w > 5.70\sqrt{E/F_y}$ ), see Appendix F1.7.

For tension-flange yield:

$$M_n = S_x R_{PG} R_e F_{yt} \quad (\text{A-G2-1})$$

For compression-flange buckling:

$$M_n = S_x R_{PG} R_e F_{cr} \quad (\text{A-G2-2})$$

**WHERE:**

$$R_{PG} = 1 - 0.0005 a_r \left( \frac{h_c}{t_w} - \frac{970}{\sqrt{F_{cr}}} \right) \leq 1.0 \quad (\text{A-G2-3})$$

For SI: 
$$R_{PG} = 1 - 0.0005 a_r \left( \frac{h_c}{t_w} - 5.70 \sqrt{\frac{E}{F_{cr}}} \right) \leq 1.0$$

$a_r$  = ratio of web area to compression flange area

$F_{cr}$  = critical compression flange stress, ksi (N/mm<sup>2</sup>)

$F_{yt}$  = yield stress of tension flange, ksi (N/mm<sup>2</sup>)

$h_c$  = twice the distance from the neutral axis to the inside face of the compression flange less the fillet or corner radius, in. (mm)

- $m$  = ratio of web yield stress to flange yield stress or  $F_{cr}$   
 $R_e$  = hybrid girder factor  
 =  $1.0 - 0.1(1.3 + a_r)(0.81 - m) \leq 1.0$  (for nonhybrid girders,  $R_e = 1.0$ )  
 $S_{xc}$  = section modulus referred to compression flange, in.<sup>3</sup> (mm<sup>3</sup>)  
 $S_{xt}$  = section modulus referred to tension flange, in.<sup>3</sup> (mm<sup>3</sup>)

The critical stress,  $F_{cr}$ , to be used is dependent upon the slenderness parameters  $\lambda$ ,  $\lambda_p$ ,  $\lambda_r$ , and  $C_{PG}$  as follows:

- a. For  $\lambda \leq \lambda_p$ :

$$F_{cr} = F_{yf} \quad (\text{A-G2-4})$$

- b. For  $\lambda_p < \lambda \leq \lambda_r$ :

$$F_{cr} = C_b F_{yf} \left[ 1 - \frac{1}{2} \left( \frac{\lambda - \lambda_p}{\lambda_r - \lambda_p} \right) \right] \leq F_{yf} \quad (\text{A-G2-5})$$

- c. For  $\lambda > \lambda_r$ :

$$F_{cr} = \frac{C_{PG}}{\lambda^2} \quad (\text{A-G2-6})$$

In the foregoing, the slenderness parameter shall be determined for both the limit state of lateral-torsional buckling and the limit state of flange local buckling; the slenderness parameter which results in the lowest value of  $F_{cr}$  governs.

For the limit state of lateral-torsional buckling:

$$\lambda = \frac{L_b}{r_T} \quad (\text{A-G2-7})$$

$$\lambda_p = \frac{300}{\sqrt{F_{yf}}} \quad (\text{A-G2-8})$$

For SI: 
$$\lambda_p = 1.76 \sqrt{\frac{E}{F_{yf}}}$$

$$\lambda_r = \frac{756}{\sqrt{F_{yf}}} \quad (\text{A-G2-9})$$

For SI: 
$$\lambda_r = 4.44 \sqrt{\frac{E}{F_{yf}}}$$

$$C_{PG} = 286,000 C_b \quad (\text{A-G2-10})$$

$$\lambda = \frac{b_f}{2_{yf}} \quad (\text{A-G2-11})$$

$$\lambda_p = \frac{65}{\sqrt{F_{yf}}} \quad (\text{A-G2-12})$$

For SI: 
$$\lambda_p = 0.38 \sqrt{\frac{E}{F_{yf}}}$$

$$\lambda_r = \frac{150}{\sqrt{F_{yf}}} \quad (\text{A-G2-13})$$

$$\begin{aligned} \text{For SI:} \quad \lambda_r &= 0.88 \sqrt{\frac{E}{F_{yf}}} \\ C_{PG} &= 11,200 \\ C_b &= 1 \end{aligned} \quad (\text{A-G2-14})$$

The limit state of flexural web local buckling is not applicable.

### G3. DESIGN SHEAR STRENGTH WITH TENSION FIELD ACTION

The design shear strength shall be  $\phi_v V_n$ , kips, where  $\phi_v = 0.90$  and  $V_n$  is determined as follows:

a. For  $h/t_w \leq 187 \sqrt{k/F_{yw}}$  (For SI:  $h/t_w \leq 1.10 \sqrt{kE/F_{yw}}$ ):

$$V_n = 0.6 A_w F_{yw} \quad (\text{A-G3-1})$$

b. For  $h/t_w > 187 \sqrt{k/F_{yw}}$  (For SI:  $h/t_w > 1.10 \sqrt{kE/F_{yw}}$ ):

$$V_n = 0.6 A_w F_{yw} \left( C_v + \frac{1 - C_v}{1.15 \sqrt{1 + (a/h)^2}} \right) \quad (\text{A-G3-2})$$

#### WHERE:

$C_v$  = ratio of "critical" web stress, according to linear buckling theory, to the shear yield stress of web material

except for end-panels in nonhybrid plate girders, for all panels in hybrid and web-tapered plate girders and when  $a/h$  exceeds 3.0 or  $[260/(h/t_w)]^2$ . In these cases, tension field action is not permitted and

$$V_n = 0.6 A_w F_{yw} C_v \quad (\text{A-G3-3})$$

The web plate buckling coefficient,  $k$ , is given as

$$k = 5 + \frac{5}{(a/h)^2} \quad (\text{A-G3-4})$$

except that  $k$  shall be taken as 5.0 if  $a/h$  exceeds 3.0 or  $[260/(h/t_w)]^2$ . The shear coefficient,  $C_v$ , is determined as follows:

For  $187 \sqrt{\frac{k}{F_{yw}}} \leq \frac{h}{t_w} \leq 234 \sqrt{\frac{k}{F_{yw}}}$  (For SI:  $1.10 \sqrt{\frac{kE}{F_{yw}}} \leq \frac{h}{t_w} \leq 1.37 \sqrt{\frac{kE}{F_{yw}}}$ ):

$$C_v = \frac{187 \sqrt{k/F_{yw}}}{h/t_w} \quad (\text{A-G3-5})$$

For SI:  $C_v = \frac{1.10 \sqrt{kE/F_{yw}}}{h/t_w}$

For  $\frac{h}{t_w} > 234 \sqrt{\frac{k}{F_{yw}}}$  (For SI:  $\frac{h}{t_w} > 1.37 \sqrt{\frac{kE}{F_{yw}}}$ ):

$$C_v = \frac{44,000 k}{(h/t_w)^2 F_{yw}} \quad (\text{A-G3-6})$$

For SI:  $C_v = \frac{1.52 kE}{(h/t_w)^2 F_{yw}}$

#### G4. TRANSVERSE STIFFENERS

Transverse stiffeners are not required in plate girders when  $h/t_w < 418/\sqrt{F_{yw}}$  (For **SI**:  $h/t_w \leq 2.45\sqrt{E/F_{yw}}$ , or when the required shear,  $V_u$ , as determined by structural analysis for the factored loads, is less than or equal to  $0.6\phi A_w F_{yw} C_v$ , where  $C_v$  is determined for  $k = 5$  and  $\phi = 0.90$ . Stiffeners may be required in certain portions of a plate girder to develop the required shear or to satisfy the limitations given in Appendix G1.

The moment of inertia,  $I_{st}$ , of a transverse stiffener about an axis in the web center for stiffener pairs or about the face in contact with the web plate for single stiffeners shall not be less than  $at_w^3 j$ , where

$$j = \frac{2.5}{(a/h)^2} - 2 \geq 0.5 \quad (\text{A-G4-1})$$

and the stiffener area,  $A_{st}$ , when designing for tension field action shall not be less than

$$\frac{F_{yw}}{F_{yst}} \left[ 0.15 D h t_w (1 - C_v) \frac{V_u}{\phi_v V_n} - 18 t_w^2 \right] \geq 0 \quad (\text{A-G4-2})$$

**WHERE:**

- $D = 1$  for stiffeners in pairs
- $= 1.8$  for single angle stiffeners
- $= 2.4$  for single plate stiffeners

$F_{yst}$  = specified yield stress of the stiffener material, ksi (N/mm<sup>2</sup>)

$C_v$  and  $V_v$  are defined in Appendix G3, and  $V_u$  is the required shear at the location of the stiffener.

#### G5. FLEXURE-SHEAR INTERACTION

Plate girders with webs that depend on tension field action must satisfy flexure-shear interaction criteria.

When stiffeners are required and

$$\frac{0.6 V_n}{M_n} \leq \frac{V_u}{M_u} \leq \frac{V_n}{0.75 M_n}$$

the following interaction equation must be satisfied:

$$\frac{M_u}{M_n} + .625 \frac{V_u}{V_n} \leq 1.375 \phi \quad (\text{A-G5-1})$$

where  $M_n$  is the nominal flexural strength of plate girders from Appendix G2,  $\phi = 0.90$  and  $V_n$  is the nominal shear strength from Appendix G3, except that  $M_u$  may not exceed  $\phi M_n$  ( $\phi = 0.90$ ) and  $V_u$  may not exceed  $\phi V_n$  ( $\phi = 0.90$ ).

### APPENDIX H

#### MEMBERS UNDER TORSION AND COMBINED FORCES

##### H3. ALTERNATE INTERACTION EQUATIONS FOR MEMBERS UNDER COMBINED STRESS

For biaxially loaded I-shaped members used in braced frames only, the following interaction equations may be used in lieu of Formulas (H1-1a) and (H1-1b).

$$\left(\frac{M_{ux}}{\phi_b M'_{px}}\right)^\zeta + \left(\frac{M_{uy}}{\phi_b M'_{py}}\right)^\zeta \leq 1.0 \quad (\text{A-H3-1})$$

$$\left(\frac{C_{mx} M_{ux}}{\phi_b M'_{nx}}\right)^\eta + \left(\frac{C_{my} M_{uy}}{\phi_b M'_{ny}}\right)^\eta \leq 1.0 \quad (\text{A-H3-2})$$

For  $0.5 \leq b_f/d \leq 1.0$ :

$$\zeta = 1.6 - \frac{P_u/P_y}{2[\ln(P_u/P_y)]} \quad (\text{A-H3-3})$$

For  $b_f/d \geq 0.3$ :

$$\begin{aligned} \eta &= 0.4 + \frac{P_u}{P_y} + \frac{b_f}{d} \geq 1.0 \quad (\text{A-H3-4}) \\ &= 1.0 \text{ for } b_f/d < 0.3 \end{aligned}$$

**WHERE:**

$b_f$  = flange width, in.

$d$  = member depth, in.

$$M'_{px} = 1.2 M_{px} [1 - (P_u/P_y)] \leq M_{px} \quad (\text{A-H3-5})$$

$$M'_{py} = 1.2 M_{py} [1 - (P_u/P_y)^2] \leq M_{py} \quad (\text{A-H3-6})$$

$$M'_{nx} = M_{nx} \left(1 - \frac{P_u}{\phi_c P_n}\right) \left(1 - \frac{P_u}{P_{ex}}\right) \quad (\text{A-H3-7})$$

$$M'_{ny} = M_{ny} \left(1 - \frac{P_u}{\phi_c P_n}\right) \left(1 - \frac{P_u}{P_{ey}}\right) \quad (\text{A-H3-8})$$

**WHERE:**

$C_m$  = coefficient defined in Section H1.

$M_n$  = nominal flexural strength, determined in accordance with Section F1, kip-in. (N·mm)

$M_p$  = plastic moment, kip-in. (N·mm)

$M_u$  = required flexural strength, kip-in. (N·mm)

$P_e$  = Euler buckling strength  $A_g F_y / \lambda_c^2$ , where  $\lambda_c$  is the column slenderness parameter defined by Formula (E2-4), kips (N)

$P_n$  = nominal compressive strength determined in accordance with Section E2, kips (N)

$P_u$  = required axial strength, kips (N)

$P_y$  = compressive yield strength  $A_g F_y$ , kips (N)

$\phi_b$  = resistance factor for flexure = 0.90

$\phi_c$  = resistance factor for compression = 0.85

## APPENDIX K

### STRENGTH DESIGN CONSIDERATIONS

#### K2. PONDING

The provisions of this Appendix may be used when a more exact determination of flat roof framing stiffness is needed than that given by the provision of Section K2 that  $C_p + 0.9C_s \leq 0.25$ .

For any combination of primary and secondary framing, the stress index is computed as

$$U_p = \left( \frac{\phi_b F_y - f_o}{f_o} \right)_p \text{ for the primary member} \quad (\text{A-K2-3})$$

$$U_s = \left( \frac{\phi_b F_y - f_o}{f_o} \right)_s \text{ for the secondary member} \quad (\text{A-K2-4})$$

**WHERE:**

$f_o$  = the stress due to  $1.2D + 1.2R$  ( $D$  = nominal dead load,  $R$  = nominal load due to rain water or ice exclusive of the ponding contribution)\*

$\phi_b$  = resistance factor for flexure = 0.90 (Section F)

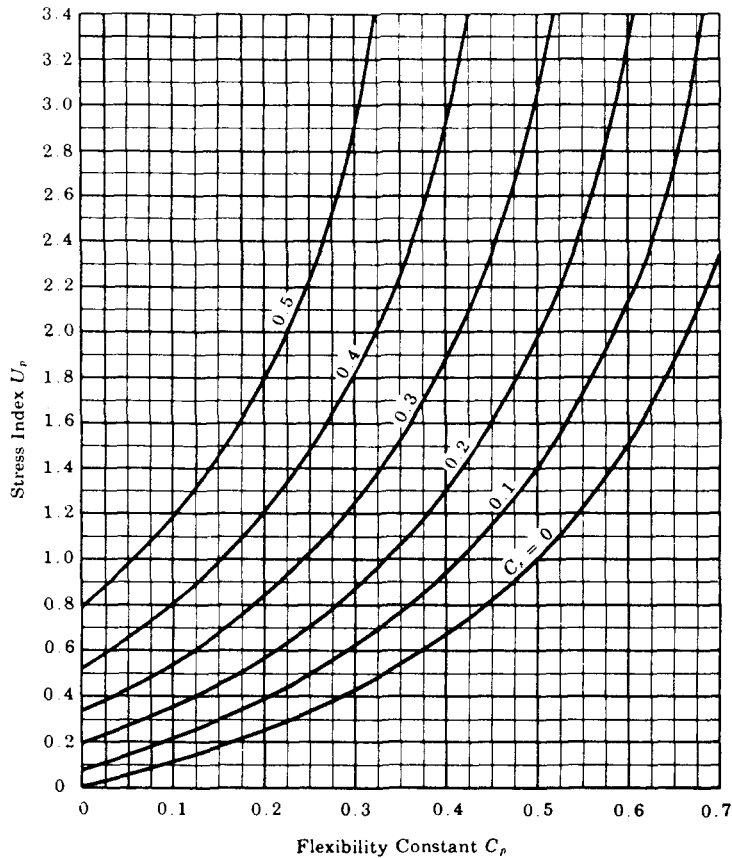

Fig. A-K2.1. Flexibility coefficients for combined primary and secondary systems

Enter Figure A-K2. 1 at the level of the computed stress index,  $U_p$ , determined for the primary beam; move horizontally to the computed  $C_s$ -value of the secondary beams and then downward to the abscissa scale. The combined stiffness of the primary and secondary framing is sufficient to pre-

\*Depending on geographic location, this loading should include such amount of snow as might also be present.

vent ponding if the flexibility constant read from this latter scale is more than the value of  $C_p$  computed for the given primary member; if not, a stiffer primary or secondary beam, or combination of both, is required. In the above,

$$C_p = \frac{32L_s L_p^4}{10^7 I_p} \quad \text{For SI: } C_p = \frac{\gamma L_s L_p^4}{\pi^4 E I_p}$$

$$C_s = \frac{32SL_s^4}{10^7 I_s} \quad \text{For SI: } C_s = \frac{\gamma S L_s^4}{\pi^4 E I_s}$$

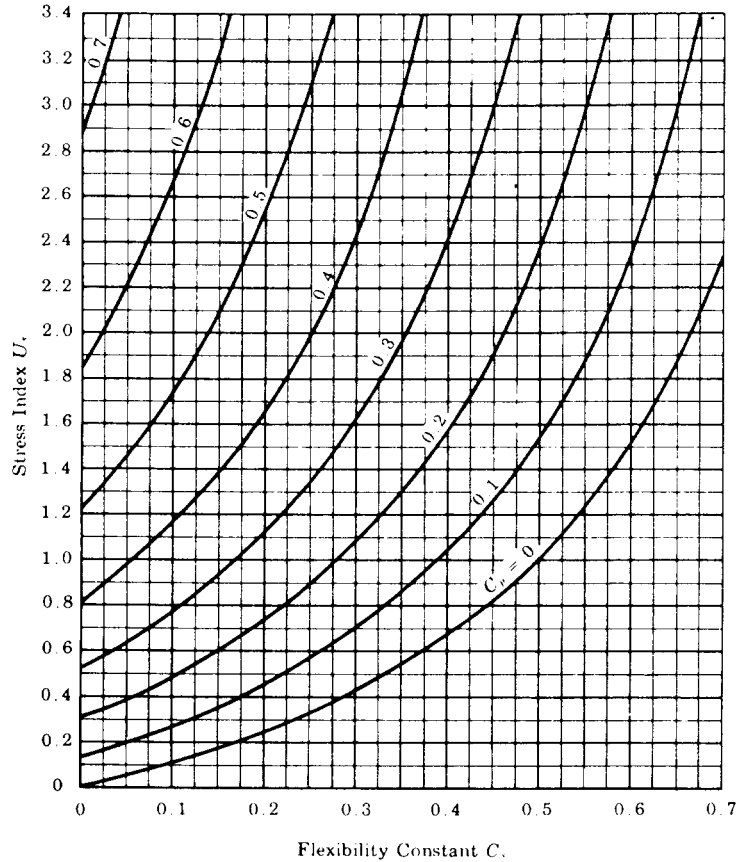

Fig. A-K2.2. Flexibility coefficients for secondary beams alone

**WHERE:**

- $I_p$  = moment of inertia of primary members, in.<sup>4</sup> (mm<sup>4</sup>)
- $I_s$  = moment of inertia of secondary members, in.<sup>4</sup> (mm<sup>4</sup>)
- $L_p$  = column spacing in direction of girder (length of primary members), ft. (m)
- $L_s$  = column spacing perpendicular to direction of girder (length of secondary members), ft. (m)
- $S$  = spacing of secondary members, ft. (m)
- $\gamma$  = the unit mass of water in kg/mm<sup>3</sup> times the acceleration of gravity in mm/s<sup>2</sup>,  $9.81 \times 10^{-6}$  N/mm<sup>2</sup>

Roof framing consisting of a series of equally spaced wall-bearing beams is considered as consisting of secondary members supported on an infinitely stiff primary member. For this case, enter Figure A-H2.2 with the computed stress index  $U_s$ . The limiting value of  $C_s$  is determined by the intercept of a horizontal line representing the  $U_s$ -value and the curve for  $C_p = 0$ .

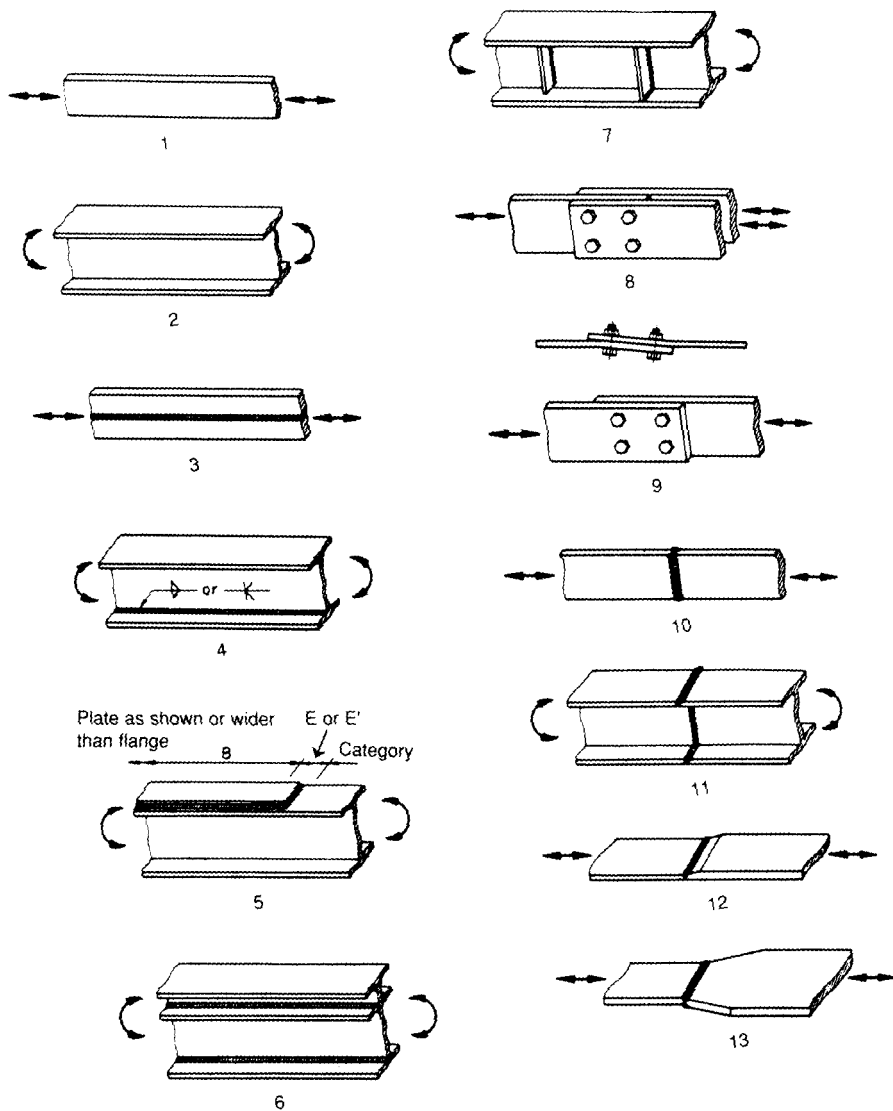

Fig. A-K4.1. Illustrative examples

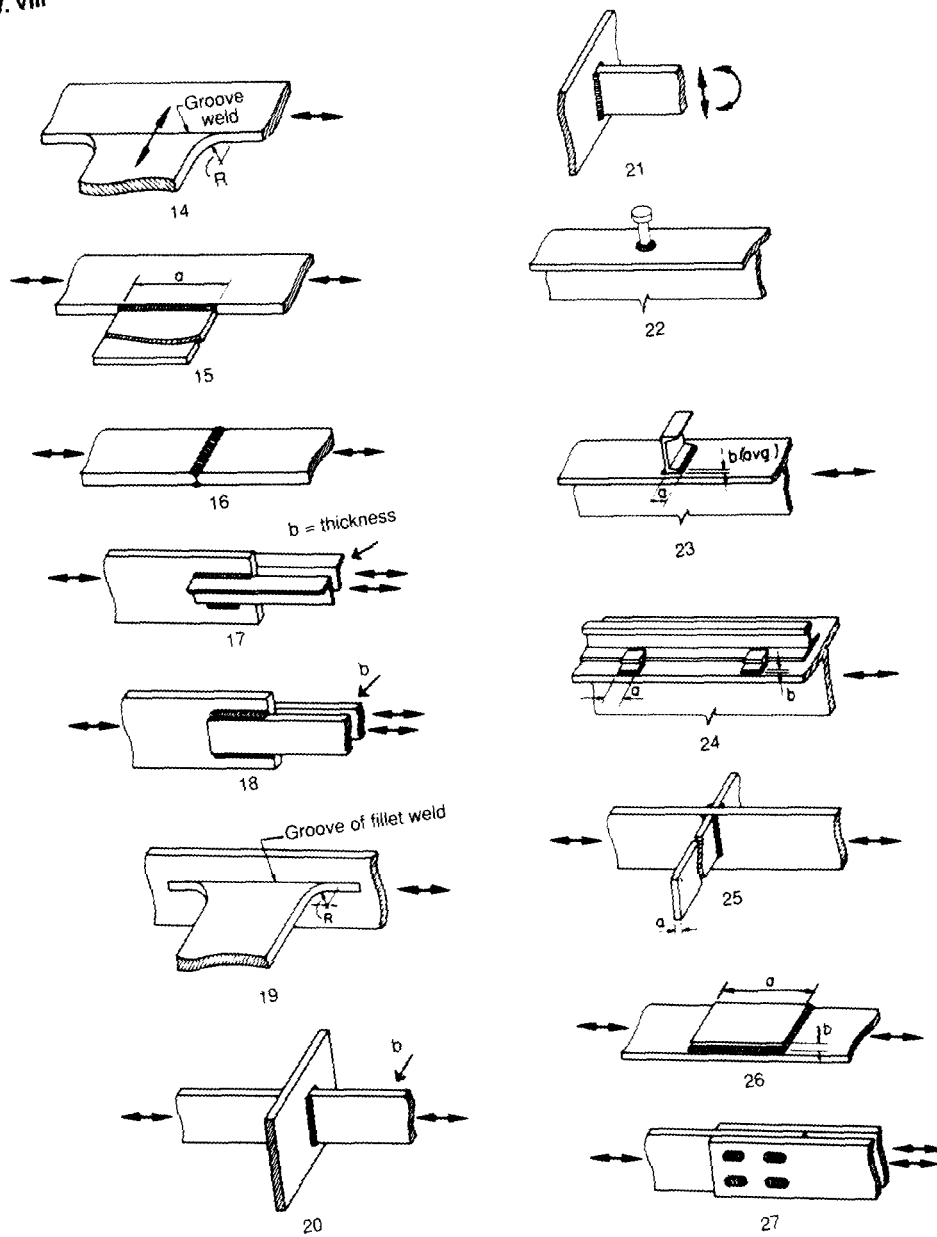

Fig. A-K4.1. Illustrative examples (continued)



The ponding deflection contributed by a metal deck is usually such a small part of the total ponding deflection of a roof panel that it is sufficient merely to limit its moment of inertia [per foot (m) of width normal to its span] to 0.000025 times the fourth power of its span length. However, the stability against ponding of a roof consisting of a metal roof deck of relatively slender depth-span ratio, spanning between beams supported directly on columns, may need to be checked. This can be done using Figure A-K2.1 or A-K2.2 using as  $C_s$  the flexibility constant for one foot width of the roof deck ( $S = 1.0$ ).

Since the shear rigidity of the web system steel joists and trusses is less than that of a solid plate, their moment of inertia should be taken as 85 percent of their chords.

**K4. FATIGUE**

Members and connections subject to fatigue loading shall be proportioned in accordance with the provisions of this Appendix.

Fatigue, as used in this Specification, is defined as the damage that may result in fracture after a sufficient number of fluctuations of stress. Stress range is defined as the magnitude of these fluctuations. In the case of a stress reversal, the stress range shall be computed as the numerical sum of maximum repeated tensile and compressive stresses or the sum of maximum shearing stresses of opposite direction at a given point, resulting from differing arrangement of live load.

**1. Loading Conditions; Type and Location of Material.** In the design of members and connections subject to repeated variation of live load, consideration shall be given to the number of stress cycles, the expected range of stress and the type and location of member or detail.

Loading conditions shall be classified according to Table A-K4.1.

The type and location of material shall be categorized according to Table A-K4.2.

**2. Design Stress Range.** The maximum range of stress at service loads shall not exceed the design stress range specified in Table A-K4.3.

**3. Design Strength of Bolts in Tension.** When subject to tensile fatigue loading, properly tightened A325 or A490 bolts shall be designed for the combined tensile design strength due to external and prying forces within limits given in Table A-K4.4.

TABLE A-K4.1  
Number of Loading Cycles

Loading Condition	From	To
1	20,000 <sup>a</sup>	100,000 <sup>b</sup>
2	100,000	500,000 <sup>c</sup>
3	500,000	2,000,000 <sup>d</sup>
4	Over 2,000,000	

<sup>a</sup>Approximately equivalent to two applications every day for 25 years.  
<sup>b</sup>Approximately equivalent to 10 applications every day for 25 years.  
<sup>c</sup>Approximately equivalent to 50 applications every day for 25 years.  
<sup>d</sup>Approximately equivalent to 200 applications every day for 25 years.

TABLE A-K4.2  
Type and Location of Material

General Condition	Situation	Kind of Stress <sup>a</sup>	Stress Category (see Table A-K4.3)	Illustrative Example Nos. (see Fig. A-K4.1) <sup>b</sup>
	× 25.4 for mm			
Plain Material	Base metal with rolled or cleaned surface. Flame-cut edges with ANSI smoothness of 1,000 or less	T or Rev.	A	1, 2
Built-up Members	Base metal and weld metal in members without attachments, built up plates or shapes connected by continuous full-penetration groove welds or by continuous fillet welds parallel to the direction of applied stress	T or Rev.	B	3, 4, 5, 6
	Base metal and weld metal in members without attachments, built-up plates, or shapes connected by full-penetration groove welds with backing bars not removed, or by partial-penetration groove welds parallel to the direction of applied stress	T or Rev.	B'	3, 4, 5, 6
	Base metal at toe of welds on girder webs or flanges adjacent to welded transverse stiffeners	T or Rev.	C	7
	Base metal at ends of partial length welded coverplates narrower than the flange having square or tapered ends, with or without welds across the ends or wider than flange with welds across the ends Flange thickness 0.8 in. Flange thickness > 0.8 in.	T or Rev. T or Rev.	E E'	5 5
	Base metal at end of partial length welded coverplates wider than the flange without welds across the ends		E'	5
Groove Welds	Base metal and weld metal at full-penetration groove welded splices of pans of similar cross section ground flush, with grinding in the direction of applied stress and with weld soundness established by weld soundness established by radiographic or ultrasonic inspection in accordance with the requirements of 9.25.2 or 9.25.3 of AWS D1.1, U.B.C. Standard No. 27-6.	T or Rev.	B	10, 11
	Base metal and weld metal at full-penetration groove welded splices at transitions in width or thickness, with welds ground to provide slopes no steeper than 1 to 2 1/2 with grinding in the direction of applied stress, and with weld soundness established by radiographic or ultrasonic inspection in accordance with the requirements of 9.25.2 or 9.25.3 of AWS D1.1, U.B.C. Standard No. 27-6.			
	A514 base metal Other base metals	T or Rev. T or Rev.	B' B	12, 13 12, 13

(Continued)

TABLE A-K4.2  
Type and Location of Material—(Continued)

General Condition	Situation	Kind of Stress <sup>a</sup>	Stress Category (see Table A-K4.3)	Illustrative Example Nos. (see Fig. A-K4.1) <sup>b</sup>
	× 25.4 for mm			
Groove Welds (cont.)	Base metal and weld metal at full-penetration groove welded splices, with or without transitions having slopes no greater than 1 to 2 <sup>1</sup> / <sub>2</sub> when reinforcement is not removed but weld soundness is established by radiographic or ultrasonic inspection in accordance with requirements of 9.25.2 or 9.25.3 of AWS 01.1, U.B.C. Standard No. 27-6.	T or Rev.	C	10, 11, 12, 13
Partial-penetration Groove Welds	Weld metal of partial-penetration transverse groove welds, based on effective throat area of the weld or welds	T or Rev.	F <sup>c</sup>	16
Fillet-welded Connections	Base metal at intermittent fillet welds	T or Rev.	E	
	Base metal at junction of axially loaded members with fillet-welded connections. Welds shall be disposed about the axis of the member so as to balance weld stresses <i>b</i> ≤ 1 in. <i>b</i> > 1 in.	T or Rev. T or Rev.	E E'	17, 18 17, 18
	Base metal at members connected with transverse fillet welds <i>b</i> ≤ 1/2 in. <i>b</i> > 1/2 in.	T or Rev.	C See Note <sup>c</sup>	20, 21
Fillet Welds	Weld metal of continuous or intermittent longitudinal or transverse fillet welds	S	F <sup>c</sup>	15, 17, 18, 20, 21
Plug or Slot Welds	Base metal at plug or slot welds	T or Rev.	E	27
	Shear on plug or slot welds	S	F	27
Mechanically Fastened Connections	Base metal at gross section of high-strength bolted slip-critical connections, except axially loaded joints which induce out-of-plane bending in connected material	T or Rev.	B	8
	Base metal at net section of other mechanically fastened joints	T or Rev.	D	8, 9
	Base metal at net section of fully tensioned high-strength, bolted, bearing connections	T or Rev.	B	8, 9

(Continued)

TABLE A-K4.2  
Type and Location of Material—(Continued)

General Condition	Situation	Kind of Stress <sup>a</sup>	Stress Category (see Table A-K4.3)	Illustrative Example Nos. (see Fig. A-K4.1) <sup>b</sup>
	× 25.4 for mm			
Attachments	Base metal at details attached by full-penetration groove welds subject to longitudinal and/or transverse loading when the detail embodies a transition radius $R$ with the weld termination ground smooth and for transverse loading, the weld soundness established by radiographic or ultrasonic inspection in accordance with 9.25.2 or 9.25.3 of AWS 01.1, U.B.C. Standard No. 27-6.			
	Longitudinal loading			
	$R > 24$ in.	T or Rev.	B	14
	$24$ in. $> R > 6$ in.	T or Rev.	C	14
	$6$ in. $> R > 2$ in.	T or Rev.	D	14
	$2$ in. $> R$	T or Rev.	E	14
	Detail base metal for transverse loading: equal thickness and reinforcement removed			
	$R > 24$ in.	T or Rev.	B	14
	$24$ in. $> R > 6$ in.	T or Rev.	C	14
	$6$ in. $> R > 2$ in.	T or Rev.	D	14
	$2$ in. $> R$	T or Rev.	E	14, 15
	Detail base metal for transverse loading: equal thickness and reinforcement not removed			
	$R > 24$ in.	T or Rev.	C	14
$24$ in. $> R > 6$ in.	T or Rev.	C	14	
$6$ in. $> R > 2$ in.	T or Rev.	D	14	
$2$ in. $> R$	T or Rev.	E	14, 15	
Detail base metal for transverse loading: unequal thickness and reinforcement removed				
$R > 24$ in.	T or Rev.	C	14	
$24$ in. $> R > 6$ in.	T or Rev.	C	14	
$6$ in. $> R > 2$ in.	T or Rev.	D	14	
$2$ in. $> R$	T or Rev.	E	14, 15	
Detail base metal for transverse loading: unequal thickness and reinforcement not removed				
all $R$	T or Rev.	E	14, 15	
Detail base metal for transverse loading				
$R > 6$ in.	T or Rev.	C	19	
$6$ in. $> R > 2$ in.	T or Rev.	D	19	
$2$ in. $> R$	T or Rev.	E	19	
Base metal at detail attached by full-penetration groove welds subject to longitudinal loading				
$2 < a < 120$ or $4$ in.	T or Rev.	D	15	
$a > 12b$ or $4$ in. when $b < 1$ in.	T or Rev.	E	15	
$a > 12b$ or $4$ in. when $b > 1$ in.	T or Rev.	E'	15	
Base metal at detail attached by fillet welds or partial-penetration groove welds subject to longitudinal loading				
$a < 2$ in.	T or Rev.	C	15, 23, 24, 25, 26	
$2$ in. $< a < 12b$ or $4$ in.	T or Rev.	D	15, 23, 24, 26	
$a > 12b$ or $4$ in. when $b < 1$ in.	T or Rev.	E	15, 23, 24, 26	
$a > 12b$ or $4$ in. when $b > 1$ in.	T or Rev.	E'	15, 23, 24, 26	

(Continued)

TABLE A-K4.2  
Type and Location of Material—(Continued)

General Condition	Situation	Kind of Stress <sup>a</sup>	Stress Category (see Table A-K4.3)	Illustrative Example Nos. (see Fig. A-K4.1) <sup>b</sup>
	× 25.4 for mm			
Attachments (cont.)	Base metal attached by fillet welds or partial-penetration groove welds subjected to longitudinal loading when the weld termination embodies a transition radius with the weld termination ground smooth: $R > 2$ in. $R < 2$ in.	T or Rev. T or Rev.	D E	19 19
	Fillet-welded attachments where the weld termination embodies a transition radius, weld termination ground smooth, and main material subject to longitudinal loading: Detail base metal for transverse loading: $R > 2$ in. $R < 2$ in.	T or Rev. T or Rev.	D E	19 19
	Base metal at stud-type shear connector attached by fillet weld or automatic end weld	T or Rev.	C	22
	Shear stress on nominal area of stud-type shear connectors	S	F	

<sup>a</sup>"T" signifies range in tensile stress only; "Rev." signifies a range involving reversal of tensile or compressive stress; "S" signifies range in shear, including shear stress reversal.  
<sup>b</sup>These examples are provided as guidelines and are not intended to exclude other reasonably similar situations.  
<sup>c</sup>Allowable fatigue stress range for transverse partial-penetration and transverse fillet welds is a function of the effective throat, depth of penetration and plate thickness.

TABLE A-K4.3  
Allowable Stress Range, ksi  
(× 6.89 for N/mm<sup>2</sup>)

Category (From Table A-K4.2)	Loading Condition 1	Loading Condition 2	Loading Condition 3	Loading Condition 4
A	63	37	24	24
B	49	29	18	16
B'	39	23	15	12
C	35	21	13	10
D	26	16	10	7
E	22	13	8	4.5
E'	16	9.2	5.8	2.6
F	15	12	9	8

Flexural stress range of 12 ksi (82.7 N/mm<sup>2</sup>) permitted at toe of stiffener welds or flanges.

TABLE A-K4.4  
Design Strength of A325 or A490 Bolts Subject to Tension

Number of cycles	Design strength
Not more than 20,000	As specified in Section J3
From 20,000 to 500,000	0.30 $A_b F_u^a$
More than 500,000	0.25 $A_b F_u^a$

<sup>a</sup>At service loads.

## NUMERICAL VALUES

**TABLE 1**  
**Design Strength as a Function of  $F_y$**

$F_y$ (ksi)	Design Stress (ksi)				
	$0.54F_y^a$	$0.55F_y^b$	$0.63F_y^c$	$0.85F_y^d$	$0.90F_y^e$
$\times 6.89$ for $N/mm^2$					
33	17.8	18.5	20.8	28.1	29.7
35	18.9	19.6	22.1	29.8	31.5
36	19.4	20.2	22.7	30.6	32.4
40	21.6	22.4	25.2	34.0	36.0
42	22.7	23.5	26.5	35.7	37.8
45	24.3	25.2	28.4	36.3	40.5
46	24.8	25.8	29.0	39.1	41.4
50	27.0	28.0	31.5	42.5	45.0
55	29.7	30.8	34.7	46.8	49.5
60	32.4	33.6	37.8	51.0	54.0
65	35.1	36.4	41.0	55.3	58.5
70	37.8	39.2	44.1	59.5	63.0
90	46.6	50.4	56.7	76.5	81.0
100	54.0	58.0	63.0	85.0	90.0

<sup>a</sup>See Sect. F2, Formulas F2-1 and F2-2  
<sup>b</sup>See Sect. J5.2, Formula J5-3  
<sup>c</sup>See Sect. K1.7, Formulas K1-9 and K1-10  
<sup>d</sup>See Sect. E2, Formula E2-1  
<sup>e</sup>See Sect. D1, Formula D1-1

TABLE 2  
Design Strength as a Function of  $F_U$

Item	ASTM Designation	$F_y$ (ksi)  × 6.89 for N/mm <sup>2</sup>	$F_U$ (ksi)  × 6.89 for N/mm <sup>2</sup>	Design Strength (ksi)				
				× 6.89 for N/mm <sup>2</sup>				
				Connected Part of Designated Steel		Bolt or Threaded Part of Designed Steel		
				Tension $0.75 \times F_U^a$	Bearing $0.75 \times 2.4F_U^b$	Tension $0.75 \times F_U^a$	Shear $0.65 \times 0.45 F_{Ud}$	Shear $0.65 \times 0.6 F_U^e$
Shapes, Plates, Bars, Sheet and Tubing or Threaded Parts	A36	36	58-80	43.5	104	32.6	17.0	22.6
	A53	35	60	45.0	108	—	—	—
	[ A242 A441 A588 ]	50	70	52.5	126	39.4	20.5	27.3
		46	67	50.3	121	37.7	19.6	26.1
		42	63	47.3	113	35.4	18.4	24.6
		40 <sup>f</sup>	60	45.0	106	33.6	17.6	23.4
	A500	33/39 <sup>g</sup>	45	33.6	81	—	—	—
		42/46 <sup>g</sup>	58	43.5	104	—	—	—
		46/50 <sup>g</sup>	62	46.5	112	—	—	—
	A501	36	56	43.5	104	—	—	—
	A529	42	60-85	45.0	108	33.8	17.6	23.4
	A570	40	55	41.3	99	—	—	—
		42	56	43.5	104	—	—	—
	A572	42	60	45.0	106	33.6	17.6	23.4
		50	65	46.6	117	36.6	19.0	25.4
60		75	56.3	135	42.2	21.9	29.3	
65		60	60.0	144	45.0	23.4	31.2	
A514	100	110-130	62.5	196	61.9	32.2	42.9	
	90	100-130	75.0	160	56.3	29.3	39.0	
A606	45	65	46.6	117	—	—	—	
	50	70	52.5	126	—	—	—	
A607	45	60	45.0	108	—	—	—	
	50	65	46.6	117	—	—	—	
	55	70	52.5	126	—	—	—	
	60	75	56.3	135	—	—	—	
	65	60	60.0	144	—	—	—	
A618	50	70	52.5	126	—	—	—	
	50	65	46.6	117	—	—	—	
Bolts	A449	92	120	—	—	67.5	35.1	46.6
		61	105	—	—	59.1	30.7	41.0
		56	90	—	—	50.6	26.3	35.1

<sup>a</sup>On effective net area, see Sects. D1, J5.2.  
<sup>b</sup>Produced by fastener in shear, see Sect. 33.6. Note that smaller maximum design bearing stresses, as a function of hole spacing, may be required by Sects. J3.9 and J3.10.  
<sup>c</sup>On nominal body area, see Table 33.2.  
<sup>d</sup>Threads not excluded from shear plane, see Table 33.2.  
<sup>e</sup>Threads excluded from shear plane, see Table 33.2.  
<sup>f</sup>For A441 material only.  
<sup>g</sup>Smaller value for circular shapes, larger for square or rectangular shapes.  
 Note: For dimensional and size limitations, see the appropriate Specification.

TABLE 3-36  
Design Stress for Compression Members of  
36 ksi (250 N/mm<sup>2</sup>) Specified Yield Stress Steel,  $\phi_c = 0.85^a$   
( $\times 6.89$  for N/mm<sup>2</sup>)

$\frac{Kl}{r}$	$\phi_c F_{cr}$ (ksi)	$\frac{Kl}{r}$	$\phi_c F_{cr}$ (ksi)	$\frac{Kl}{r}$	$\phi_c F_{cr}$ (ksi)	$\frac{Kl}{r}$	$\phi_c F_{cr}$ (ksi)	$\frac{Kl}{r}$	$\phi_c F_{cr}$ (ksi)
1	30.60	41	28.01	81	21.66	121	14.16	161	8.23
2	30.59	42	27.89	82	21.48	122	13.98	182	8.13
3	30.59	43	27.76	83	21.29	123	13.80	183	8.03
4	30.57	44	27.64	84	21.11	124	13.62	164	7.93
5	30.56	45	27.51	85	20.92	125	13.44	165	7.84
6	30.54	48	27.37	86	20.73	126	13.27	166	7.74
7	30.52	47	27.24	87	20.54	127	13.09	167	7.65
8	30.50	48	27.11	88	20.36	128	12.92	188	7.56
9	30.47	49	26.97	89	20.17	129	12.74	169	7.47
10	30.44	50	26.63	90	19.98	130	12.57	170	7.38
11	30.41	51	26.68	91	19.79	131	12.40	171	7.30
12	30.37	52	26.54	92	19.60	132	12.23	172	7.21
13	30.33	53	26.39	93	19.41	133	12.06	173	7.13
14	30.29	54	26.25	94	19.22	134	11.88	174	7.05
15	30.24	55	26.10	95	19.03	135	11.71	175	6.97
16	30.19	56	25.94	96	18.84	136	11.54	176	6.89
17	30.14	57	25.79	97	18.65	137	11.37	177	6.81
18	30.08	58	25.63	98	18.46	138	11.20	178	6.73
19	30.02	59	25.48	99	18.27	139	11.04	179	6.68
20	29.96	60	25.32	100	18.08	140	10.89	180	6.59
21	29.90	61	25.16	101	17.89	141	10.73	181	6.51
22	29.63	62	24.99	102	17.70	142	10.58	182	6.44
23	29.76	63	24.83	103	17.51	143	10.43	163	6.37
24	29.69	64	24.67	104	17.32	144	10.29	184	6.30
25	29.61	65	24.50	105	17.13	145	10.15	185	6.23
26	29.53	66	24.33	106	16.94	146	10.01	186	6.17
27	29.45	67	24.16	107	16.75	147	9.87	187	6.10
28	29.36	68	23.99	108	16.56	148	9.74	188	6.04
29	29.28	69	23.82	109	16.37	149	9.61	189	5.97
30	29.18	70	23.64	110	16.19	150	9.48	190	5.91
31	29.09	71	23.47	111	16.00	151	9.36	191	5.85
32	28.99	72	23.29	112	15.81	152	9.23	192	5.79
33	28.90	73	23.12	113	15.63	153	9.11	193	5.73
34	28.79	74	22.94	114	15.44	154	9.00	194	5.67
35	28.69	75	22.76	115	15.26	155	8.88	195	5.61
36	28.58	76	22.58	116	15.07	158	8.77	198	5.55
37	28.47	77	22.40	117	14.89	157	8.66	197	5.50
38	28.36	78	22.22	118	14.70	158	8.55	198	5.44
39	28.25	79	22.03	119	14.52	159	8.44	199	5.39
40	28.13	80	21.85	120	14.34	160	8.33	200	5.33

<sup>a</sup>When element width-to-thickness ratio exceeds  $\lambda_r$ , see Appendix B5.3.

TABLE 3-50  
Design Stress for Compression Members of  
50 ksi (345 N/mm<sup>2</sup>) Specified Yield Stress Steel,  $\phi_c = 0.85^a$   
( $\times 6.89$  for N/mm<sup>2</sup>)

$\frac{Kl}{r}$	$\phi_c F_{cr}$ (ksi)	$\frac{Kl}{r}$	$\phi_c F_{cr}$ (ksi)	$\frac{Kl}{r}$	$\phi_c F_{cr}$ (ksi)	$\frac{Kl}{r}$	$\phi_c F_{cr}$ (ksi)	$\frac{Kl}{r}$	$\phi_c F_{cr}$ (ksi)
1	42.50	41	37.59	81	26.31	121	14.57	161	8.23
2	42.49	42	37.36	82	26.00	122	14.33	162	8.13
3	42.47	43	37.13	83	25.68	123	14.10	163	8.03
4	42.45	44	36.89	84	25.37	124	13.88	164	7.93
5	42.42	45	36.65	85	25.06	125	13.66	165	7.84
6	42.39	46	36.41	86	24.75	126	13.44	166	7.74
7	42.35	47	36.16	87	24.44	127	13.23	167	7.65
8	42.30	48	35.91	88	24.13	128	13.02	168	7.56
9	42.25	49	35.66	89	23.82	129	12.82	169	7.47
10	42.19	50	35.40	90	23.51	130	12.62	170	7.38
11	42.13	51	35.14	91	23.20	131	12.43	171	7.30
12	42.05	52	34.88	92	22.89	132	12.25	172	7.21
13	41.98	53	34.61	93	22.58	133	12.06	173	7.13
14	41.90	54	34.34	94	22.28	134	11.88	174	7.05
15	41.81	55	34.07	95	21.97	135	11.71	175	6.97
16	41.71	56	33.79	96	21.67	136	11.54	176	6.89
17	41.61	57	33.51	97	21.36	137	11.37	177	6.81
18	41.51	58	33.23	98	21.06	138	11.20	178	6.73
19	41.39	59	32.95	99	20.76	139	11.04	179	6.66
20	41.28	60	32.67	100	20.46	140	10.89	180	6.59
21	41.15	61	32.38	101	20.16	141	10.73	181	6.51
22	41.02	62	32.09	102	19.86	142	10.58	182	6.44
23	40.89	63	31.80	103	19.57	143	10.43	183	6.37
24	40.75	64	31.50	104	19.28	144	10.29	184	6.30
25	40.60	65	31.21	105	18.98	145	10.15	185	6.23
26	40.45	66	30.91	106	18.69	146	10.01	186	6.17
27	40.29	67	30.61	107	18.40	147	9.87	187	6.10
28	40.13	68	30.31	108	18.12	148	9.74	188	6.04
29	39.97	69	30.01	109	17.83	149	9.61	189	5.97
30	39.79	70	29.70	110	17.55	150	9.48	190	5.91
31	39.62	71	29.40	111	17.27	151	9.36	191	5.85
32	39.43	72	29.09	112	16.99	152	9.23	192	5.79
33	39.25	73	28.79	113	16.71	153	9.11	193	5.73
34	39.06	74	28.48	114	16.42	154	9.00	194	5.67
35	38.86	75	28.17	115	16.13	155	8.88	195	5.61
36	38.66	76	27.86	116	15.86	156	8.77	196	5.55
37	38.45	77	27.55	117	15.59	157	8.66	197	5.50
38	38.24	78	27.24	118	15.32	158	8.55	198	5.44
39	38.03	79	26.93	119	15.07	159	8.44	199	5.39
40	37.81	80	26.62	120	14.82	160	8.33	200	5.33

<sup>a</sup>When element width-to-thickness ratio exceeds  $\lambda_r$ , see Appendix 85.3.

TABLE 4  
Values of  $\phi_c F_{cr} / F_y$ ,  $\phi_c = 0.85$   
For Determining Design Stress for Compression Members for Steel of Any Yield Stress<sup>a</sup>

	$\lambda_c$	$\phi F_{cr}/F_y$	$\lambda_c$	$\phi F_{cr}/F_y$	$\lambda_c$	$\phi F_{cr}/F_y$	$\lambda_c$	$\phi F_{cr}/F_y$
	All grades of steel	0.02	0.850	0.82	0.641	1.62	0.284	2.42
0.04		0.849	0.84	0.632	1.64	0.277	2.44	0.125
0.06		0.849	0.86	0.623	1.66	0.271	2.46	0.123
0.08		0.848	0.88	0.614	1.68	0.264	2.48	0.121
0.10		0.846	0.90	0.605	1.70	0.258	2.50	0.119
0.12		0.845	0.92	0.596	1.72	0.252	2.52	0.117
0.14		0.843	0.94	0.587	1.74	0.246	2.54	0.116
0.16		0.841	0.96	0.578	1.76	0.241	2.56	0.114
0.18		0.839	0.98	0.568	1.78	0.235	2.58	0.112
0.20		0.836	1.00	0.559	1.80	0.230	2.60	0.110
0.22		0.833	1.02	0.550	1.82	0.225	2.62	0.109
0.24		0.830	1.04	0.540	1.84	0.220	2.64	0.107
0.26		0.826	1.06	0.531	1.86	0.215	2.66	0.105
0.28		0.823	1.08	0.521	1.88	0.211	2.68	0.104
0.30		0.819	1.10	0.512	1.90	0.206	2.70	0.102
0.32		0.814	1.12	0.503	1.92	0.202	2.72	0.101
0.34		0.810	1.14	0.493	1.94	0.198	2.74	0.099
0.36		0.805	1.16	0.484	1.96	0.194	2.76	0.098
0.38		0.800	1.18	0.474	1.98	0.190	2.78	0.096
0.40		0.795	1.20	0.465	2.00	0.186	2.80	0.095
0.42		0.789	1.22	0.456	2.02	0.183	2.82	0.094
0.44		0.784	1.24	0.446	2.04	0.179	2.84	0.092
0.46		0.778	1.26	0.437	2.06	0.176	2.86	0.091
0.48		0.772	1.28	0.428	2.08	0.172	2.88	0.090
0.50		0.765	1.30	0.419	2.10	0.169	2.90	0.089
0.52		0.759	1.32	0.410	2.12	0.166	2.92	0.087
0.54		0.752	1.34	0.401	2.14	0.163	2.94	0.086
0.56		0.745	1.36	0.392	2.16	0.160	2.96	0.085
0.58		0.738	1.38	0.383	2.18	0.157	2.98	0.084
0.60		0.731	1.40	0.374	2.20	0.154	3.00	0.083
0.62		0.724	1.42	0.365	2.22	0.151	3.02	0.082
0.64		0.716	1.44	0.357	2.24	0.149	3.04	0.081
0.66		0.708	1.46	0.348	2.26	0.146	3.06	0.080
0.68		0.700	1.48	0.339	2.28	0.143	3.08	0.079
0.70		0.692	1.50	0.331	2.30	0.141	3.10	0.078
0.72		0.684	1.52	0.323	2.32	0.138	3.12	0.077
0.74		0.676	1.54	0.314	2.34	0.136	3.14	0.076
0.76		0.667	1.56	0.306	2.36	0.134	3.16	0.075
0.78		0.659	1.58	0.299	2.38	0.132	3.18	0.074
0.80		0.650	1.60	0.291	2.40	0.129	3.20	0.073

<sup>a</sup>When element width-to-thickness ratios exceed  $\lambda_r$ , see Appendix B5.3.  
Values of  $\lambda_c > 2.24$  exceed  $Kl/r$  of 200 for  $F_y = 36$ .  
Values of  $\lambda_c > 2.64$  exceed  $Kl/r$  of 200 for  $F_y = 50$ .

TABLE 5  
Values of  $Kl/r$  for  $F_y = 36$  and 50 ksi (250 and 345 N/mm<sup>2</sup>)

$\lambda_c$	$Kl/r$		$\lambda_c$	$Kl/r$	
	$F_y = 36$	$F_y = 50$		$F_y = 36$	$F_y = 50$
0.02	1.8	1.5	0.82	73.1	62.0
0.04	3.6	3.0	0.84	74.9	63.6
0.06	5.3	4.5	0.86	76.7	65.1
0.08	7.1	6.1	0.80	78.5	66.6
0.10	8.9	7.6	0.90	80.2	68.1
0.12	10.7	9.1	0.92	82.0	69.6
0.14	12.5	10.6	0.94	83.8	71.1
0.16	14.3	12.1	0.96	85.6	72.6
0.18	16.0	13.6	0.98	87.4	74.1
0.20	17.8	15.1	1.00	89.2	75.7
0.22	19.6	16.6	1.02	90.9	77.2
0.24	21.4	18.2	1.04	92.7	78.7
0.26	23.2	19.7	1.06	94.5	80.2
0.28	25.0	21.2	1.08	96.3	81.7
0.30	26.7	22.7	1.10	98.1	83.2
0.32	28.5	24.2	1.12	99.9	84.7
0.34	30.3	25.7	1.14	101.6	86.3
0.36	32.1	27.2	1.16	103.4	87.8
0.38	33.9	28.8	1.18	105.2	89.3
0.40	35.7	30.3	1.20	107.0	90.8
0.42	37.4	31.8	1.22	108.8	92.3
0.44	39.2	33.3	1.24	110.6	93.8
0.46	41.0	34.8	1.26	112.3	95.3
0.48	42.8	36.3	1.28	114.1	96.8
0.50	44.6	37.8	1.30	115.9	98.4
0.52	46.4	39.3	1.32	117.7	99.9
0.54	48.1	40.9	1.34	119.5	101.4
0.56	49.9	42.4	1.36	121.3	102.9
0.58	51.7	43.9	1.38	123.0	104.4
0.60	53.5	45.4	1.40	124.8	105.9
0.62	55.3	46.9	1.42	126.6	107.4
0.64	57.1	48.4	1.44	128.4	108.9
0.66	58.8	49.9	1.46	130.2	110.5
0.68	60.6	51.4	1.48	132.0	112.0
0.70	62.4	53.0	1.50	133.7	113.5
0.72	64.2	54.5	1.52	135.5	115.0
0.74	66.0	56.0	1.54	137.3	116.5
0.76	67.8	57.5	1.56	139.1	118.0
0.78	69.5	59.0	1.58	140.9	119.5
0.80	71.3	60.5	1.60	142.7	121.1

TABLE 5 (cont'd)  
Values of  $Kl/r$  for  $F_y = 36$  and  $50$  ksi (250 and 345 N/mm<sup>2</sup>)

$\lambda_c$	$Kl/r$		$\lambda_c$	$Kl/r$
	$F_y = 36$	$F_y = 50$		
1.62	144.4	122.6	2.42	183.1
1.64	146.2	124.1	2.44	184.6
1.66	148.0	125.6	2.46	186.1
1.68	149.8	127.1	2.48	187.6
1.70	151.6	128.6	2.50	189.1
1.72	153.4	130.1	2.52	190.7
1.74	155.1	131.6	2.54	192.2
1.76	156.9	133.2	2.56	193.7
1.78	158.7	134.7	2.58	195.2
1.80	160.5	136.2	2.60	196.7
1.82	162.3	137.7	2.62	198.2
1.84	164.1	139.2	2.64	199.7
1.86	165.8	140.7		
1.88	167.6	142.2		
1.90	169.4	143.8		
1.92	171.2	145.3		
1.94	173.0	146.8		
1.96	174.8	148.3		
1.98	176.5	149.8		
2.00	178.3	151.3		
2.02	180.1	152.8		
2.04	181.9	154.3		
2.06	183.7	155.9		
2.08	185.5	157.4		
2.10	187.2	158.9		
2.12	189.0	160.4		
2.14	190.8	161.9		
2.16	192.6	163.4		
2.18	194.4	164.9		
2.20	196.2	166.5		
2.22	197.9	168.0		
2.24	199.7	169.5		
2.26		171.0		
2.28		172.5		
2.30		174.0		
2.32		175.5		
2.34		177.0		
2.36		178.6		
2.38		180.1		
2.40		181.6		

Heavy line indicates  $Kl/r$  of 200.

TABLE 6  
Slenderness Ratios of Elements as a Function of  $F_y$   
From Table B5.1

Ratio	$F_y$ (ksi)					
	× 6.89 for N/mm <sup>2</sup>					
	36	42	46	50	60	65
$65/\sqrt{F_y}$	10.8	10.0	9.6	9.2	8.4	8.1
$76/\sqrt{F_y}$	12.7	11.7	11.2	10.7	9.8	9.4
$95/\sqrt{F_y}$	15.8	14.7	14.0	13.4	12.3	11.8
$106/\sqrt{F_y - 16.5}$	24.0	21.0	19.5	18.3	16.1	15.2
$127/\sqrt{F_y}$	21.2	19.6	18.7	18.0	16.4	15.8
$141/\sqrt{F_y - 10}$	27.7	24.9	23.5	22.3	19.9	19.0
$190/\sqrt{F_y}$	31.7	29.3	28.0	26.9	24.5	23.6
$238/\sqrt{F_y - 10}$	46.7	42.1	39.7	37.6	33.7	32.1
$238/\sqrt{F_y - 16.5}$	53.9	47.1	43.8	41.1	36.1	34.2
$253/\sqrt{F_y}$	42.2	39.0	37.3	35.8	32.7	31.4
$317/\sqrt{F_y - 10}$	62.2	56.0	52.8	50.1	44.8	42.7
$640/\sqrt{F_y}$	107	98.8	94.4	90.5	82.6	79.4
$970/\sqrt{F_y}$	162	150	143	137	125	120
$1,300/F_y$	36.1	31.0	28.3	26.0	21.7	20.0
$2,070/F_y$	57.5	49.3	45.0	41.4	34.5	31.8
$3,300/F_y$	91.7	78.6	71.7	66.0	55.0	50.8
$8,970/F_y$	249	214	195	179	150	138

TABLE 7  
Values of  $C_b$   
For Use in Chapters F and G

$\frac{M_1}{M_2}$	$C_b$	$\frac{M_1}{M_2}$	$C_b$	$\frac{M_1}{M_2}$	$C_b$
-1.00	1.00	-0.45	1.34	0.10	1.86
-0.95	1.02	-0.40	1.38	0.15	1.91
-0.90	1.05	-0.35	1.42	0.20	1.97
-0.85	1.07	-0.30	1.46	0.25	2.03
-0.80	1.10	-0.25	1.51	0.30	2.09
-0.75	1.13	-0.20	1.55	0.35	2.15
-0.70	1.16	-0.15	1.60	0.40	2.22
-0.65	1.19	-0.10	1.65	0.45	2.28
-0.60	1.23	-0.05	1.70	$\geq 0.47$	2.30
-0.55	1.26	0	1.75		
-0.50	1.30	0.05	1.80		

Note 1:  $C_b = 1.75 + 1.05(M_1/M_2) + 0.3(M_1/M_2)^2 \leq 2.3$   
 Note 2:  $M_1/M_2$  positive for reverse curvature and negative for single curvature.

TABLE 8  
Values of  $C_m$   
For Use in Section H1

$\frac{M_1}{M_2}$	$C_m$	$\frac{M_1}{M_2}$	$C_m$	$\frac{M_1}{M_2}$	$C_m$
-1.00	1.00	-0.45	0.78	0.10	0.56
-0.95	0.98	-0.40	0.76	0.15	0.54
-0.90	0.96	-0.35	0.74	0.20	0.52
-0.85	0.94	-0.30	0.72	0.25	0.50
-0.80	0.92	-0.25	0.70	0.30	0.48
-0.75	0.90	-0.20	0.68	0.35	0.46
-0.70	0.88	-0.15	0.66	0.40	0.44
-0.65	0.86	-0.10	0.64	0.45	0.42
-0.60	0.84	-0.05	0.62	0.50	0.40
				0.60	0.36
-0.55	0.82	0	0.60	0.80	0.28
-0.50	0.80	0.05	0.58	1.00	0.20

Note 1:  $C_m = 0.6 - 0.4(M_1/M_2)$ .  
 Note 2:  $M_1/M_2$  is positive for reverse curvature and negative for single curvature.

TABLE 9  
Values of  $P_e/A_g$   
For Use in Section H1 for Steel of Any Yield Stress

$K/r$	$P_e/A_g$ (ksi) (× 6.89 for N/mm <sup>2</sup> )	$K/r$	$P_e/A_g$ (ksi) (× 6.89 for N/mm <sup>2</sup> )	$K/r$	$P_e/A_g$ (ksi) (× 6.89 for N/mm <sup>2</sup> )	$K/r$	$P_e/A_g$ (ksi) (× 6.89 for N/mm <sup>2</sup> )	$K/r$	$P_e/A_g$ (ksi) (× 6.89 for N/mm <sup>2</sup> )	$K/r$	$P_e/A_g$ (ksi) (× 6.89 for N/mm <sup>2</sup> )
21	649.02	51	110.04	81	43.62	111	23.23	141	14.40	171	9.79
22	591.36	52	105.85	82	42.57	112	22.82	142	14.19	172	9.67
23	541.06	53	101.89	83	41.55	113	22.42	143	14.00	173	9.56
24	496.91	54	98.15	84	40.56	114	22.02	144	13.80	174	9.45
25	457.95	55	94.62	85	39.62	115	21.64	145	13.61	175	9.35
26	423.40	56	91.27	86	38.70	116	21.27	146	13.43	176	9.24
27	392.62	57	88.09	87	37.81	117	20.91	147	13.25	177	9.14
28	365.07	58	85.08	88	36.96	118	20.56	148	13.07	178	9.03
29	340.33	59	82.22	89	36.13	119	20.21	149	12.89	179	8.93
30	318.02	60	79.51	90	35.34	120	19.88	150	12.72	180	8.83
31	297.83	61	76.92	91	34.56	121	19.55	151	12.55	181	8.74
32	279.51	62	74.46	92	33.82	122	19.23	152	12.39	182	8.64
33	262.83	63	72.11	93	33.09	123	18.92	153	12.23	183	8.55
34	247.59	64	69.88	94	32.39	124	18.61	154	12.07	184	8.45
35	233.65	65	67.74	95	31.71	125	18.32	155	11.91	185	8.36
36	220.85	66	65.71	96	31.06	126	18.03	156	11.76	186	8.27
37	209.07	67	63.76	97	30.42	127	17.75	157	11.61	187	8.18
38	198.21	68	61.90	98	29.80	128	17.47	158	11.47	188	8.10
39	188.18	69	60.12	99	29.20	129	17.20	159	11.32	189	8.01
40	178.89	70	58.41	100	28.62	130	16.94	160	11.18	190	7.93
41	170.27	71	56.78	101	28.06	131	16.68	161	11.04	191	7.85
42	162.26	72	55.21	102	27.51	132	16.43	162	10.91	192	7.76
43	154.80	73	53.71	103	26.98	133	16.18	163	10.77	193	7.68
44	147.84	74	52.27	104	26.46	134	15.94	164	10.64	194	7.60
45	141.34	75	50.88	105	25.96	135	15.70	165	10.51	195	7.53
46	135.26	76	49.55	106	25.47	136	15.47	166	10.39	196	7.45
47	129.57	77	48.27	107	25.00	137	15.25	167	10.26	197	7.38
48	124.23	78	47.04	108	24.54	138	15.03	168	10.14	198	7.30
49	119.21	79	45.86	109	24.09	139	14.81	169	10.02	199	7.23
50	114.49	80	44.72	110	23.65	140	14.60	170	9.90	200	7.16

Note:  $P_e/A_g = \frac{\pi^2 E}{(K/r)^2}$

TABLE 10-36

$$\frac{\phi_v V_n}{A_w} \text{ (ksi) for Plate Girders by Section F2}$$

For 36 ksi (250 N/mm<sup>2</sup>) Yield Stress Steel, Tension Field Action Not Included  
(× 6.89 for N/mm<sup>2</sup>)

$\frac{h}{t_w}$	Aspect Ratio $a/h$ : Stiffener Spacing to Web Depth													
	0.5	0.6	0.7	0.8	0.9	1.0	1.2	1.4	1.6	1.8	2.0	2.5	3.0	Over 3.0
60	19.4	19.4	19.4	19.4	19.4	19.4	19.4	19.4	19.4	19.4	19.4	19.4	19.4	19.4
70	19.4	19.4	19.4	19.4	19.4	19.4	19.4	19.4	19.4	19.4	19.4	19.4	19.4	19.4
80	19.4	19.4	19.4	19.4	19.4	19.4	19.4	19.4	19.4	19.4	18.9	18.2	17.9	16.9
90	19.4	19.4	19.4	19.4	19.4	19.4	19.4	18.5	17.8	17.2	16.8	16.2	15.9	14.7
100	19.4	19.4	19.4	19.4	19.4	19.2	17.6	16.6	16.0	15.5	14.9	13.8	13.2	11.9
110	19.4	19.4	19.4	19.4	18.4	17.4	16.0	14.8	13.7	12.8	12.3	11.4	10.9	9.8
120	19.4	19.4	19.4	18.1	16.9	16.0	14.0	12.5	11.5	10.8	10.3	9.6	9.2	8.3
130	19.4	19.4	18.2	16.7	15.6	14.1	11.9	10.6	9.8	9.2	8.8	8.2	7.8	7.0
140	19.4	18.8	16.9	15.5	13.5	12.1	10.3	9.2	8.4	7.9	7.6	7.0	6.7	6.1
150	19.4	17.6	15.7	13.5	11.8	10.6	8.9	8.0	7.3	6.9	6.6	6.1	5.9	5.3
160	18.9	16.5	14.1	11.9	10.4	9.3	7.9	7.0	6.5	6.1	5.8	5.4		4.6
170	17.8	15.5	12.5	10.5	9.2	8.2	7.0	6.5	5.7	5.4	5.1			4.1
180	16.8	13.9	11.1	9.4	8.2	7.3	6.2	5.5	5.1	4.8	4.6			3.7
200	14.9	11.2	9.0	7.6	6.6	5.9	5.0	4.5	4.1					3.0
220	12.3	9.3	7.5	6.3	5.5	4.9	4.2							2.5
240	10.3	7.8	6.3	5.3	4.6	4.1								2.1
260	8.8	6.6	5.3	4.5	3.9	3.5								1.8
280	7.6	5.7	4.6	3.9										
300	6.6	5.0	4.0											
320	5.8	4.4												

TABLE 10-50

$$\frac{\phi_v V_n}{A_w} \text{ (ksi) for Plate Girders by Section F2 Aw}$$

For 50 ksi (345 N/mm<sup>2</sup>) Yield Stress Steel, Tension Field Action Not Included  
(× 6.89 for N/mm<sup>2</sup>)

$\frac{h}{t_w}$	Aspect Ratio $a/h$ : Stiffener Spacing to Web Depth													
	0.5	0.6	0.7	0.8	0.9	1.0	1.2	1.4	1.6	1.8	2.0	2.5	3.0	Over 3.0
60	27.0	27.0	27.0	27.0	27.0	27.0	27.0	27.0	27.0	27.0	27.0	27.0	27.0	26.6
70	27.0	27.0	27.0	27.0	27.0	27.0	27.0	27.0	26.9	26.1	25.5	24.6	24.0	22.8
80	27.0	27.0	27.0	27.0	27.0	27.0	26.0	24.5	23.5	22.8	22.3	21.5	20.6	18.6
90	27.0	27.0	27.0	27.0	26.5	25.1	23.1	21.8	20.4	19.2	18.3	17.0	16.3	14.7
100	27.0	27.0	27.0	25.6	23.9	22.6	20.1	17.9	16.5	15.5	14.9	13.8	13.2	11.9
110	27.0	27.0	25.3	23.2	21.7	19.6	16.6	14.8	13.7	12.8	12.3	11.4	10.9	9.8
120	27.0	25.9	23.2	21.1	18.4	16.5	14.0	12.5	11.5	10.8	10.3	9.6	9.2	8.3
130	27.0	23.9	21.4	18.0	15.7	14.1	11.9	10.6	9.8	9.2	8.8	8.2	7.8	7.0
140	25.5	22.2	18.4	15.5	13.5	12.1	10.3	9.2	8.4	7.9	7.6	7.0	6.7	6.1
150	23.8	19.9	16.1	13.5	11.8	10.6	8.9	8.0	7.3	6.9	6.6	6.1	5.9	5.3
160	22.3	17.5	14.1	11.9	10.4	9.3	7.9	7.0	6.5	6.1	5.8	5.4		4.6
170	20.6	15.5	12.5	10.5	9.2	8.2	7.0	6.2	5.7	5.4	5.1			4.1
180	18.3	13.9	11.1	9.4	8.2	7.3	6.2	5.5	5.1	4.8	4.6			3.7
200	14.9	11.2	9.0	7.6	6.6	5.9	5.0	4.5	4.1					3.0
220	12.3	9.3	7.5	6.3	5.5	4.9	4.2							2.5
240	10.3	7.8	6.3	5.3	4.6	4.1								2.1
260	8.8	6.6	5.3	4.5	3.9	3.5								
280	7.6	5.7	4.6	3.9										

TABLE 11-36

$$\frac{\phi_v V_n}{A_w} \text{ (ksi [N/mm}^2\text{)] for Plate Girders by Appendix G}$$

For 36 ksi (250 N/mm<sup>2</sup>) Yield Stress Steel, Tension Field Action Included<sup>b</sup> (*Italic* values indicate gross area, as percent of ( $h \times t_w$ ) required for pairs of intermediate stiffeners of 36 ksi (250 N/mm<sup>2</sup>) yield stress steel with  $V_u / \phi V_n = 1.0$ .)<sup>a</sup>  
( $\times 6.89$  for N/mm<sup>2</sup>)

$\frac{h}{t_w}$	Aspect Ratio $a/h$ : Stiffener Spacing to Web Depth													
	0.5	0.6	0.7	0.8	0.9	1.0	1.2	1.4	1.6	1.8	2.0	2.5	3.0	Over 3.0 <sup>c</sup>
60	19.4	19.4	19.4	19.4	19.4	19.4	19.4	19.4	19.4	19.4	19.4	19.4	19.4	19.4
70	19.4	19.4	19.4	19.4	19.4	19.4	19.4	19.4	19.4	19.4	19.4	19.4	19.4	19.4
80	19.4	19.4	19.4	19.4	19.4	19.4	19.4	19.4	19.4	19.4	19.1	18.6	18.3	16.9
90	19.4	19.4	19.4	19.4	19.4	19.4	19.4	19.0	18.5	18.2	17.8	17.3	16.8	14.7
100	19.4	19.4	19.4	19.4	19.4	19.3	18.6	18.1	17.6	17.2	16.6	15.6	14.9	11.9
110	19.4	19.4	19.4	19.4	19.1	18.7	17.9	17.2	16.3	15.6	15.1	14.0	13.3	9.8
120	19.4	19.4	19.4	19.0	18.5	18.1	17.0	16.0	15.1	14.4	13.9	12.8	12.0	8.3
130	19.4	19.4	19.1	18.6	18.1	17.4	16.1	15.1	14.2	13.5	12.9	11.8	11.0	7.0
140	19.4	19.3	18.7	18.2	17.4	16.6	15.4	14.4	13.5	12.8	12.2	11.0	10.2	6.1
150	19.4	19.0	18.4	17.5	16.7	16.0	14.8	13.8	12.9	12.2	11.6	10.4	9.6	5.3
160	19.3	18.7	17.9	17.0	16.2	15.5	14.3	13.3	12.4	11.7	11.1	9.9		4.6
170	19.1	18.4	17.4	16.6	15.8	15.1	13.9	12.9	12.0	11.3 <i>0.3</i>	10.7 <i>0.4</i>			4.1
180	18.9	18.0	17.1	16.2	15.5	14.8	13.6 <i>0.2</i>	12.6 <i>0.7</i>	11.7 <i>1.1</i>	11.0 <i>1.3</i>	10.4 <i>1.5</i>			3.7
200	18.4	17.3	16.4	15.6 <i>0.1</i>	14.9 <i>0.9</i>	14.2 <i>1.4</i>	13.1 <i>2.1</i>	12.0 <i>2.5</i>	11.2 <i>2.8</i>					3.0
220	17.8	16.9	16.0 <i>1.1</i>	15.2 <i>2.0</i>	14.5 <i>2.6</i>	13.8 <i>3.0</i>	12.7 <i>3.6</i>							2.5
240	17.4	16.5 <i>1.5</i>	15.7 <i>2.7</i>	14.9 <i>3.4</i>	14.2 <i>3.9</i>	13.5 <i>4.3</i>								2.1
260	17.1 <i>1.3</i>	16.2 <i>3.0</i>	15.4 <i>4.0</i>	14.6 <i>4.6</i>	14.0 <i>5.0</i>	13.3 <i>5.4</i>								1.8
280	16.8 <i>2.7</i>	16.0 <i>4.2</i>	15.2 <i>5.0</i>	14.4 <i>5.6</i>										
300	16.6 <i>3.9</i>	15.8 <i>5.2</i>	15.0 <i>5.9</i>											
320	16.4 <i>4.9</i>	15.6 <i>6.0</i>												

<sup>a</sup>For area of single-angle and single-plate stiffeners, or when  $V_u / \phi V_n < 1.0$ , see Formula A-G4-2.  
<sup>b</sup>For end-panels and all panels in hybrid and web-tapered plate girders use Table 10-36.  
<sup>c</sup>Same as for Table 10-36.  
 Note: Girders so proportioned that the computed shear is less than that given in right-hand column do not require intermediate stiffeners.

TABLE 11-50

$$\frac{\phi_v V_n}{A_w} \text{ (ksi [N/mm}^2\text{)] for Plate Girders by Appendix G}$$

For 50 ksi (345 N/mm<sup>2</sup>) Yield Stress Steel, Tension Field Action Included<sup>b</sup> (*Italic* values indicate gross area, as percent of (*h* x *tw*) required for pairs of intermediate stiffeners of 50 ksi (345 N/mm<sup>2</sup>) yield stress steel with  $V_u/\phi V_n = 1.0$ .)<sup>a</sup>  
(× 6.89 for N/mm<sup>2</sup>)

$\frac{h}{t_w}$	Aspect Ratio <i>a/h</i> : Stiffener Spacing to Web Depth													Over 3.0 <sup>c</sup>
	0.5	0.6	0.7	0.8	0.9	1.0	1.2	1.4	1.6	1.8	2.0	2.5	3.0	
60	27.0	27.0	27.0	27.0	27.0	27.0	27.0	27.0	27.0	27.0	27.0	27.0	27.0	26.6
70	27.0	27.0	27.0	27.0	27.0	27.0	27.0	27.0	26.9	26.5	26.1	25.4	24.9	22.8
80	27.0	27.0	27.0	27.0	27.0	27.0	26.5	25.8	25.1	24.6	24.1	23.3	22.4	18.6
90	27.0	27.0	27.0	27.0	26.8	26.3	25.3	24.4	23.4	22.5	21.7	20.2	19.2	14.7
100	27.0	27.0	27.0	26.5	25.9	25.3	24.0	22.5	21.4	20.4	19.6	18.0	17.0	11.9
110	27.0	27.0	26.5	25.8	25.1	24.2	22.4	21.0	19.8	18.8	18.0	16.4	15.3	9.8
120	27.0	26.7	25.9	25.1	24.0	23.0	21.2	19.8	18.6	17.6	16.8	15.2	14.1	8.3
130	27.0	26.2	25.4	24.1	23.0	22.0	20.3	18.9	17.7	16.7	15.9	14.2	13.1	7.0
140	26.7	25.8	24.5	23.3	22.2	21.3	19.6	18.2	17.0	16.0	15.1	13.5	12.3	6.1
150	26.3	25.2	23.9	22.7	21.6	20.7	19.0	17.6	16.4	15.4	14.5	12.9	11.7	5.3
160	26.0	24.6	23.3	22.2	21.1	20.2	18.5	17.1	15.9	14.9	14.0	12.4		4.6
170	25.6	24.1	22.8	21.7	20.7	19.8	18.1	16.7	15.5	14.5	13.6			4.1
180							0.5	1.0	1.2	1.4	1.6			
190							0.4	0.9	1.5	1.9	2.2	2.3	2.5	
200	24.3	23.0	21.8	20.8	19.8	18.9	17.3	15.9	14.7					3.0
210			1.0	1.8	2.3	2.7	3.2	3.5	3.7					
220	23.7	22.5	21.4	20.4	19.4	18.5	16.9							2.5
230		1.7	2.7	3.3	3.8	4.1	4.5							
240	23.2	22.1	21.0	20.0	19.1	18.2								2.1
250	1.8	3.2	4.0	4.6	4.9	5.2								
260	23.0	21.8	20.8	19.8	18.8	18.0								
270	3.2	4.4	5.1	5.6	5.9	6.1								
280	22.7	21.6	20.6	19.6										
290	4.4	5.4	6.0	6.4										

<sup>a</sup>For area of single-angle and single-plate stiffeners, or when  $V_u/\phi V_n < 1.0$ , see Formula A-G4-2.  
<sup>b</sup>For end-panels and all panels in hybrid and web-tapered plate girders use Table 10-50.  
<sup>c</sup>Same as for Table 10-50.  
 Note: Girders so proportioned that the computed shear is less than that given in right-hand column do not require intermediate stiffeners.

TABLE 12  
Nominal Horizontal Shear Load for One Connector  $Q_n$ , kips<sup>a</sup>  
From Formulas I5-1 and I5-2  
( $\times 4.45$  for N)

Connector <sup>b</sup>	Specified Compressive Strength of Concrete, $f'_c$ ksi <sup>d</sup>		
	$\times 6.89$ for N/mm <sup>2</sup>		
$\times 25.4$ for mm	3.0	3.5	4.0
1/2-in. dia. x 2-in. hooked or headed stud	9.4	10.5	11.6
5/8-in. dia. x 2 1/2-in. hooked or headed stud	14.6	16.4	18.1
3/4-in. dia. x 3-in. hooked or headed stud	21.0	23.6	26.1
7/8-in. dia. x 3 1/2-in. hooked or headed stud	28.6	32.1	35.5
Channel C3 x 4.1	10.2 $L_c^c$	11.5 $L_c^c$	12.7 $L_c^c$
Channel C4 x 5.4	11.1 $L_c^c$	12.4 $L_c^c$	13.8 $L_c^c$
Channel C5 x 6.7	11.9 $L_c^c$	13.3 $L_c^c$	14.7 $L_c^c$

<sup>a</sup>Applicable only to concrete made with C33 aggregates.  
<sup>b</sup>The design horizontal loads tabulated may also be used for studs longer than shown.  
<sup>c</sup> $L_c$  = length of channel, inches.  
<sup>d</sup> $F_u > 0.5(f'_c w)^{.75}$ ,  $w = 145$  lbs./cu. ft.

TABLE 13  
Coefficients for Use with Concrete Made with C330 Aggregates  
to Adjust Values from Table 12 for Lightweight Concrete

Specified Compressive Strength of Concrete ( $f'_c$ )	Air Dry Unit Weight of Concrete, pcf						
	$\times 16$ for kg/m <sup>3</sup>						
$\times 6.89$ for N/mm <sup>2</sup>	90	95	100	105	110	115	120
4.0 ksi	0.73	0.76	0.78	0.81	0.83	0.86	0.88
5.0 ksi	0.82	0.85	0.87	0.91	0.93	0.96	0.99

**Division IX—DESIGN STANDARD FOR ALLOWABLE STRESS DESIGN AND  
PLASTIC DESIGN FOR STRUCTURAL STEEL BUILDINGS**

**Based on Specification for Structural Steel Buildings Allowable Stress Design  
and Plastic Design of the American Institute of Steel Construction, Inc.  
(June 1, 1989)**

Section 2250 of this division contains the exceptions to the referenced specification. Section 2251 of this division is "Allowable Stress Design and Plastic Design for Structural Buildings" reproduced with permission of the publisher.

**SECTION 2250 — SCOPE**

Except for the limitations, deletions, modifications or amendments set forth in this section, buildings or structures may be designed in accordance with Section 2251 of this division. When other codes, standards or specifications are referred to in this standard, they are to be considered as only an indication of an acceptable method or material that can be used with the approval of the building official. Part II of this standard is amended as follows:

1. **Sec. A1. Modify as follows:**  
This standard is intended as an alternative to Division VIII.
2. **Sec. A2.1. Modify the last sentence as follows:**  
For the design of cold-formed steel structural members, whose profiles contain rounded comers and slender flat elements, the provisions of Division V shall apply.
3. **Sec. A4. Modify as follows:**  
The nominal loads shall be the minimum design loads required by the code.
4. **Secs. A4.1, A4.4 and A4.5. Delete.**

**SECTION 2251 — ADOPTION**

Reproduced with permission from the American Institute of Steel Construction, 1 East Wacker Drive, Suite 3100, Chicago, Illinois 60601. Persons desiring to reprint in whole or in part any portion of this specification must secure permission from the American Institute of Steel Construction, Inc.

**TABLE OF CONTENTS**

**A. GENERAL PROVISIONS**

- A1. Scope (Modified per Part I)**
- A2. Limits of Applicability**
  1. Structural Steel Defined (Modified per Part I)
  2. Types of Construction
- A3. Material**
  1. Structural Steel
  2. Steel Castings and Forgings
  3. Rivets
  4. Bolts, Washers and Nuts
  5. Anchor Bolts and Threaded Rods
  6. Filler Metal and Flux for Welding
  7. Stud Shear Connectors

- A4. Loads and Forces (Modified per Part I)**
  - 1. Dead Load and Live Load (Deleted per Part I)
  - 2. Impact
  - 3. Crane Runway Horizontal Forces
  - 4. Wind (Deleted per Part I)
  - 5. Other Forces (Deleted per Part I)
- A5. Design Basis**
  - 1. Allowable Stresses
  - 2. Wind and Seismic Stresses
  - 3. Structural Analysis
  - 4. Design for Serviceability and Other Considerations
- A6. Referenced Codes and Standards**
- A7. Design Documents**
  - 1. Plans
  - 2. Standard Symbols and Nomenclature
  - 3. Notation for Welding
- B. DESIGN REQUIREMENTS**
  - B1. Gross Area**
  - B2. Net Area**
  - B3. Effective Net Area**
  - B4. Stability**
  - B5. Local Buckling**
    - 1. Classification of Steel Sections
    - 2. Slender Compression Elements (Deleted per Part I)
  - B6. Rotational Restraint at Points of Support**
  - B7. Limiting Slenderness Ratios**
  - B8. Simple Spans**
  - B9. End Restraint**
  - B10. Proportions of Beams and Girders**
  - B11. Proportioning of Crane Girders**
- C. FRAMES AND OTHER STRUCTURES**
  - C1. General**
  - C2. Frame Stability**
    - 1. Braced Frames
    - 2. Unbraced Frames
- D. TENSION MEMBERS**
  - D1. Allowable Stress**
  - D2. Built-up Members**
  - D3. Pin-connected Members**
    - 1. Allowable Stress
    - 2. Pin-connected Plates
    - 3. Eyebars
- E. COLUMNS AND OTHER COMPRESSION MEMBERS**
  - E1. Effective Length and Slenderness Ratio**
  - E2. Allowable Stress**

- E3. Flexural-torsional Buckling**
- E4. Built-up Members**
- E5. Pin-connected Compression Members**
- E6. Column Web Shear**

**F. BEAMS AND OTHER FLEXURAL MEMBERS**

- F1. Allowable Stress: Strong Axis Bending of I-shaped Members and Channels**
  - 1. Members with Compact Sections
  - 2. Members with Noncompact Sections
  - 3. Members with Compact or Noncompact Sections with Unbraced Length Greater than  $L_c$
- F2. Allowable Stress: Weak Axis Bending of I-shaped Members, Solid Bars and Rectangular Plates**
  - 1. Members with Compact Sections
  - 2. Members with Noncompact Sections
- F3. Allowable Stress: Bending of Box Members, Rectangular Tubes and Circular Tubes**
  - 1. Members with Compact Sections
  - 2. Members with Noncompact Sections
- F4. Allowable Shear Stress**
- F5. Transverse Stiffeners**
- F6. Built-up Members**
- F7. Web-tapered Members (Deleted per Part I)**

**G. PLATE GIRDERS**

- G1. Web Slenderness Limitations**
- G2. Allowable Bending Stress**
- G3. Allowable Shear Stress with Tension Field Action**
- G4. Transverse Stiffeners**
- G5. Combined Shear and Tension Stress**

**H. COMBINED STRESSES**

- H1. Axial Compression and Bending**
- H2. Axial Tension and Bending**

**I. COMPOSITE CONSTRUCTION**

- I1. Definition**
- I2. Design Assumptions**
- I3. End Shear**
- I4. Shear Connectors**
- I5. Composite Beams or Girders with Formed Steel Deck**
  - 1. General
  - 2. Deck Ribs Oriented Perpendicular to Steel Beam or Girder
  - 3. Deck Ribs Oriented Parallel to Steel Beam or Girder
- I6. Special Cases**

**J. CONNECTIONS, JOINTS AND FASTENERS**

- J1. General Provisions**
  - 1. Design Basis

2. Simple Connections
3. Moment Connections
4. Compression Members with Bearing Joints
5. Connections of Tension and Compression Members in Trusses
6. Minimum Connections
7. Splices in Heavy Sections
8. Beam Copes and Weld Access Holes
9. Placement of Welds, Bolts and Rivets
10. Bolts in Combination with Welds
11. High-strength Bolts in Slip-critical Connections in Combination with Rivets
12. Limitations on Bolted and Welded Connections

**J2. Welds**

1. Groove Welds
2. Fillet Welds
3. Plug and Slot Welds
4. Allowable Stresses
5. Combination of Welds
6. Mixed Weld Metal
7. Preheat for Heavy Shapes

**J3. Bolts, Threaded Parts and Rivets**

1. High-strength Bolts
2. Size and Use of Holes
3. Effective Bearing Area
4. Allowable Tension and Shear
5. Combined Tension and Shear in Bearing-type Connections
6. Combined Tension and Shear in Slip-critical Joints
7. Allowable Bearing at Bolt Holes
8. Minimum Spacing
9. Minimum Edge Distance
10. Maximum Edge Distance and Spacing
11. Long Grips

**J4. Allowable Shear Rupture**

**J5. Connecting Elements**

1. Eccentric Connections
2. Allowable Shear Rupture

**J6. Fillers**

**J7. Splices**

**J8. Allowable Bearing Stress**

**J9. Column Bases and Bearing on Masonry and Concrete**

**J10. Anchor Bolts**

**K. SPECIAL DESIGN CONSIDERATIONS**

**K1. Webs and Flanges under Concentrated Forces**

1. Design Basis
2. Local Flange Bending
3. Local Web Yielding

4. Web Crippling
5. Sidesway Web Buckling
6. Compression Buckling of the Web
7. Compression Members with Web Panels Subject to High Shear
8. Stiffener Requirements for Concentrated Loads

**K2. Ponding****K3. Torsion****K4. Fatigue****L. SERVICEABILITY DESIGN CONSIDERATIONS****L1. Camber****L2. Expansion and Contraction****L3. Deflection, Vibration and Drift**

1. Deflection
2. Vibration

**L4. Connection Slip (see Section J3)****L5. Corrosion****M. FABRICATION, ERECTION AND QUALITY CONTROL****M1. Shop Drawings****M2. Fabrication**

1. Cambering, Curving and Straightening
2. Thermal Cutting
3. Planing of Edges
4. Welded Construction
5. High-strength Bolted Construction—Assembly
6. Compression Joints
7. Dimensional Tolerances
8. Finishing of Column Bases

**M3. Shop Painting**

1. General Requirements
2. Inaccessible Surfaces
3. Contact Surfaces
4. Finished Surfaces
5. Surfaces Adjacent to Field Welds

**M4. Erection**

1. Alignment of Column Bases
2. Bracing
3. Alignment
4. Fit of Column Compression Joints
5. Field Welding
6. Field Painting
7. Field Connections

**M5. Quality Control**

1. Cooperation
2. Rejections

3. Inspection of Welding
4. Inspection of Slip-critical, High-strength Bolted Connections
5. Identification of Steel

**N. PLASTIC DESIGN**

**N1. Scope**

**N2. Structural Steel**

**N3. Basis for Maximum Strength Determination**

1. Stability of Braced Frames
2. Stability of Unbraced Frames

**N4. Columns**

**N5. Shear**

**N6. Web Crippling**

**N7. Minimum Thickness (Width-thickness Ratios)**

**N8. Connections**

**N9. Lateral-Bracing**

**N10. Fabrication**

**APPENDICES**

**B. DESIGN REQUIREMENTS**

**B5. Local Buckling**

2. Slender Compression Elements

**F. BEAMS AND OTHER FLEXURAL MEMBERS**

**F7. Web-tapered Members**

1. General Requirements
2. Allowable Tensile Stress
3. Allowable Compressive Stress
4. Allowable Flexural Stress
5. Allowable Shear
6. Combined Flexure and Axial Force

**K. STRENGTH DESIGN CONSIDERATIONS**

**K4. Fatigue**

1. Loading Conditions; Type and Location of Material
2. Allowable Stress Range
3. Tensile Fatigue

**NUMERICAL VALUES**

**SYMBOL**

## CHAPTER A GENERAL PROVISIONS

### A1. SCOPE

Modified—See Part I.

### A2. LIMITS OF APPLICABILITY

**1. Structural Steel Defined.** As used in this Specification, the term *structural steel* refers to the steel elements of the structural steel frame essential to the support of the design loads. Such elements are generally enumerated in Section 2.1 of the AISC *Code of Standard Practice for Steel Buildings and Bridges*. For the design of cold-formed carbon or low-alloy steel structural members, profiles of which contain rounded corners and slender flat elements, the provisions of Chapter 22, Divisions V and X shall apply.

**2. Types of Construction.** Three basic types of construction and associated design assumptions are permissible under the respective conditions stated herein, and each will govern in a specific manner the size of members and the types and strength of their connections:

Type 1, commonly designated as “rigid-frame” (continuous frame), assumes that beam-to-column connections have sufficient rigidity to hold virtually unchanged the original angles between intersecting members.

Type 2, commonly designated as “simple framing” (unrestrained, free-ended), assumes that, insofar as gravity loading is concerned, ends of beams and girders are connected for shear only and are free to rotate under gravity load.

Type 3, commonly designated as “semi-rigid framing” (partially restrained), assumes that the connections of beams and girders possess a dependable and known moment capacity intermediate in degree between the rigidity of Type 1 and the flexibility of Type 2.

The design of all connections shall be consistent with the assumptions as to type of construction called for on the design drawings.

Type 1 construction is unconditionally permitted under this Specification. Two different methods of design are recognized. Within the limitations laid down in Section N1, members of continuous frames or continuous portions of frames may be proportioned, on the basis of their maximum predictable strength, to resist the specified design loads multiplied by the prescribed load factors. Otherwise, Type 1 construction shall be designed, within the limitations of Chapters A through M, to resist the stresses produced by the specified design loads, assuming moment distribution in accordance with the elastic theory.

Type 2 construction is permitted under this Specification, subject to the stipulations of the following paragraph, wherever applicable.

In buildings designed as Type 2 construction (i.e., with beam-to-column connections other than wind connections assumed flexible under gravity loading) the wind moments may be distributed among selected joints of the frame, provided:

1. Connections and connected members have adequate capacity to resist wind moments.
2. Girders are adequate to carry full gravity load as “simple beams.”
3. Connections have adequate inelastic rotation capacity to avoid overstress of the fasteners or welds under combined gravity and wind loading.

Type 3 (semirigid) construction is permitted upon evidence the connections to be used are capable of furnishing, as a minimum, a predictable proportion of full end restraint. The proportioning of main members joined by such connections shall be predicated upon no greater degree of end restraint than this minimum.

Types 2 and 3 construction may necessitate some nonelastic, but self-limiting, deformation of a structural steel part.

### A3. MATERIAL

**1. Structural Steel. a. ASTM designations.** Material conforming to one of the following standard specifications is approved for use under this Specification:

A 36, A 53 (Grade B), A 242, A 441, A 500, A 501, A 514, A 529, A 570 (Grade 40, 45 and 50), A 572, A588, A 606, A 607, A 618, A 709 and A 852.

Certified mill test reports or certified reports of tests made by the fabricator or a testing laboratory in accordance with ASTM A 6 or A 568, as applicable, and the governing specification shall constitute sufficient evidence of conformity with one of the above ASTM standards. Additionally, the fabricator shall, if requested, provide an affidavit stating the structural steel furnished meets the requirements of the grade specified.

**b. Unidentified steel.** Unidentified steel, if free from surface imperfections, is permitted for parts of minor importance, or for unimportant details, where the precise physical properties of the steel and its weldability would not affect the strength of the structure.

**c. Heavy shapes.** For A 6 Groups 4 and 5 rolled shapes to be used as members subject to primary tensile stresses due to tension or flexure, toughness need not be specified if splices are made by bolting. If such members are spliced using full penetration welds, the steel shall be specified in the contract documents to be supplied with Charpy V-Notch testing in accordance with ASTM A 6, Supplementary Requirement S5. The impact test shall meet a minimum average value of 20 ft-lbs. (188.3 N·mm) absorbed energy at 70°F. (21°C.) and shall be conducted in accordance with ASTM A 673 with the following exceptions:

a. The center longitudinal axis of the specimens shall be located as near as practical to midway between the inner flange surface and the center of the flange thickness at the intersection with the web mid-thickness.

b. Tests shall be conducted by the producer on material selected from a location representing the top of each ingot or part of an ingot used to produce the product represented by these tests.

For plates exceeding 2 inches (51 mm) thick used for built-up members with bolted splices and subject to primary tensile stresses due to tension or flexure, material toughness need not be specified. If such members are spliced using full penetration welds, the steel shall be specified in the contract documents to be supplied with Charpy V-Notch testing in accordance with ASTM A 6, Supplementary Requirement S5. The impact test shall be conducted by the producer in accordance with ASTM A 673, Frequency P, and shall meet a minimum average value of 20 ft-lbs. (183 N·mm) absorbed energy at + 70°F. (21°C.).

The above supplementary toughness requirements shall also be considered for welded full-penetration joints other than splices in heavy rolled and built-up members subject to primary tensile stresses.

Additional requirements for joints in heavy rolled and built-up members are given in Sections J1.7, J1.8, J2.6, J2.7 and M2.2.

**2. Steel Castings and Forgings.** Cast steel shall conform to one of the following standard specifications:

A27, Grade 65-36 and A148 Grade 80-50.

Steel forgings shall conform to the following standard specification:

A668

Certified test reports shall constitute sufficient evidence of conformity with the standards.

Allowable stresses shall be the same as those provided for other steels, where applicable.

**3. Rivets.** Steel rivets shall conform to the following standard specification:

A502

Manufacturer's certification shall constitute sufficient evidence of conformity with the standard.

**4. Bolts, Washers and Nuts.** Steel bolts shall conform to one of the following standard specifications:

A307, A325, A449, A490, A563 and F436.

A449 bolts are permitted only in connections requiring bolt diameters greater than 1 1/2 inches (38 mm) and shall not be used in slip-critical connections.

Manufacturer's certification shall constitute sufficient evidence of conformity with the standards.

**5. Anchor Bolts and Threaded Rods.** Anchor bolt and threaded rod steel shall conform to one of the following standard specifications:

Structural Steel, ASTM A 36

A36, A194, Grade 7, A354, A449, A572, A588 and A687.

Threads on bolts and rods shall conform to Unified Standard Series of ANSI B18.1-72 and shall have Class 2A tolerances.

Steel bolts conforming to other provisions of Section A3 are permitted as anchor bolts. A449 material is acceptable for high-strength anchor bolts and threaded rods of any diameter.

Manufacturer's certification shall constitute sufficient evidence of conformity with the standards.

**6. Filler Metal and Flux for Welding.** Welding electrodes and fluxes shall conform to one of the following specifications of the American Welding Society\*:

A5.1, A5.5, A5.17, A5.18, A5.20, A5.23, A5.28 and A5.29.

Manufacturer's certification shall constitute sufficient evidence of conformity with the standards.

**7. Stud Shear Connectors.** Steel stud shear connectors shall conform to the requirement of the *AWS Structural Welding Code—Steel*, D1.1.

Manufacturer's certification shall constitute sufficient evidence of conformity with the code.

**A4. LOADS AND FORCES**

Modified. See Part I.

The nominal loads shall be the minimum design loads required by the code.

**1. Dead Load and Live Load.** Deleted per Part I.

**2. Impact.** For structures carrying live loads\*\* which induce impact, the assumed live load shall be increased sufficiently to provide for same.

If not otherwise specified, the increase shall not be less than:

For supports of elevators . . . . .	100%
For cab-operated traveling crane support girders and their connections . . . . .	25%
For pendant-operated traveling crane support girders and their connections . . . . .	10%
For supports of light machinery, shaft or motor driven . . . . .	20%

\*Approval of these welding electrode specifications is given without regard to weld metal notch toughness requirements, which are generally not critical for building construction.

\*\*Live loads on crane support girders shall be taken as the maximum crane wheel loads.

- For supports of reciprocating machinery or power driven units . . . . . 50%
- For hangers supporting floors and balconies . . . . . 33%

**3. Crane Runway Horizontal Forces.** The lateral force on crane runways to provide for the effect of moving crane trolleys shall not be less than 20 percent of the sum of weights of the lifted load and of the crane trolley, but exclusive of other parts of the crane. The force shall be assumed to be applied at the top of the rails, acting in either direction normal to the runway rails, and shall be distributed with due regard for lateral stiffness of the structure supporting the rails.

The longitudinal tractive force shall not be less than 10 percent of the maximum wheel loads of the crane applied at the top of the rail, unless otherwise specified.

The crane runway shall also be designed for crane stop forces.

**4. Wind.** Deleted per Part I.

**5. Other Forces.** Deleted per Part I.

#### A5. DESIGN BASIS

**1. Allowable Stresses.** Except as provided in Chapter N, all structural members, connections and connectors shall be proportioned so the stresses due to the working loads do not exceed the allowable stresses specified in Chapters D through K. The allowable stresses specified in these chapters do not apply to peak stresses in regions of connections (see also Section B9), provided requirements of Chapter K are satisfied.

For provisions pertaining to plastic design, refer to Chapter N.

**2. Wind and Seismic Stresses.** Allowable stresses may be increased one third above the values otherwise provided when produced by wind or seismic loading, acting alone or in combination with the design dead and live loads, provided the required section computed on this basis is not less than that required for the design dead and live load and impact (if any) computed without the one third stress increase, and further provided that stresses are not otherwise required to be calculated on the basis of reduction factors applied to design loads in combinations.

**3. Structural Analysis.** The stresses in members, connections and connectors shall be determined by structural analysis for the loads defined in Section A4. Selection of the method of analysis is the prerogative of the responsible engineer.

**4. Design for Serviceability and Other Considerations.** The overall structure and the individual members, connections and connectors shall be checked for serviceability in accordance with Chapter L.

#### A6. REFERENCED CODES AND STANDARDS

Where codes and standards are referenced in this Specification, the editions of the following listed adoption dates are intended:

American Institute for Steel Construction

Code of Standard Practice for Steel Buildings and Bridges, 1986.

American National Standards Institute

B18.1-72

A58.1-82

American Society for Testing and Materials

A 6-87d

A 27-87

A 36-87

A 53-88

A 148-84

A 242-87

A 307-86a

A 325-86

A 354-86

A 441-85

A 449-87

A 490-85

A 500-84	A 501-84	A 514-87a
A 529-85	A 563-84	A 570-85
A 572-85	A 588-87	A 606-85
A 607-85	A 618-84	A 668-85a
A 687-84	C 33-86	C 330-87
F 436-86	A 502-83A	A 709-87b
A 852-85		
American Welding Society		
D1.1-88	A5.1-81	A5.5-81
A5.17-80	A5.18-79	A5.20-79
A5.23-80	A5.28-79	A5.29-80
Research Council on Structural Connections		

*Specification for Structural Joints Using ASTM A325 or A490 Bolts, 1985.*

## A7. DESIGN DOCUMENTS

**1. Plans.** The design plans shall show a complete design with sizes, sections and relative locations of the various members. Floor levels, column centers and offsets shall be dimensioned. Drawings shall be drawn to a scale large enough to show the information clearly.

Design documents shall indicate the type or types of construction as defined in Section A2.2 and shall include the loads and design requirements necessary for preparation of shop drawings including shears, moments and axial forces to be resisted by all members and their connections.

Where joints are to be assembled with high-strength bolts, design documents shall indicate the connection type (slip-critical, tension or bearing).

Camber of trusses, beams and girders, if required, shall be called for in the design documents. The requirements for stiffeners and bracing shall be shown on the design documents.

**2. Standard Symbols and Nomenclature.** Welding and inspection symbols used on plans and shop drawings shall preferably be the American Welding Society symbols. Other adequate welding symbols are permitted, provided a complete explanation thereof is shown in the design documents.

**3. Notation for Welding.** Notes shall be made in the design documents and on the shop drawings of those joints or groups of joints in which the welding sequence and technique of welding shall be carefully controlled to minimize distortion.

Weld lengths called for in the design documents and on the shop drawings shall be the net effective lengths.

## CHAPTER B

### DESIGN REQUIREMENTS

This chapter contains provisions which are common to the Specification as a whole.

#### B1. GROSS AREA

The gross area of a member at any point shall be determined by summing the products of the thickness and the gross width of each element as measured normal to the axis of the member.

For angles, the gross width shall be the sum of the widths of the legs less the thickness.

#### B2. NET AREA

The net area,  $A_n$ , of a member is the sum of the products of the thickness and the net width of each element computed as follows:

The width of a bolt or rivet hole shall be taken as  $1/16$  inch (1.6 mm) greater than the nominal dimension of the hole.

For a chain of holes extending across a part in any diagonal or zigzag line, the net width of the part shall be obtained by deducting from the gross width the sum of the diameters or slot dimensions as provided in Section J3.2, of all holes in the chain, and adding, for each gage space in the chain, the quantity

$$s^2/4g$$

**WHERE:**

$s$  = longitudinal center-to-center spacing (pitch) of any two consecutive holes, in. (mm)

$g$  = transverse center-to-center spacing (gage) between fastener gage lines, in. (mm)

For angles, the gage for holes in opposite adjacent legs shall be the sum of the gages from the back of the angles less the thickness.

The critical net area,  $A_n$ , of the part is obtained from that chain which gives the least net width.

In determining the net area across plug or slot welds, the weld metal shall not be considered as adding to the net area.

**B3. EFFECTIVE NET AREA**

When the load is transmitted directly to each of the cross-sectional elements by connectors, the effective net area,  $A_e$ , is equal to the net area  $A_n$ .

When the load is transmitted by bolts or rivets through some but not all of the cross-sectional elements of the member, the effective net area,  $A_e$ , shall be computed as:

$$A_e = UA_n \tag{B3-1}$$

**WHERE:**

$A_n$  = net area of the member, in.<sup>2</sup> (mm<sup>2</sup>)

$U$  = reduction coefficient

When the load is transmitted by welds through some but not all of the cross-sectional elements of the member, the effective net area,  $A_e$ , shall be computed as:

$$A_e = UA_g \tag{B3-2}$$

**WHERE:**

$A_g$  = gross area of member, in.<sup>2</sup> (mm<sup>2</sup>)

Unless a larger coefficient is justified by tests or other criteria, the following values of  $U$  shall be used:

- a. W, M or S shapes with flange widths not less than two thirds the depth, and structural tees cut from these shapes, provided the connection is to the flanges. Bolted or riveted connections shall have no fewer than three fasteners per line in the direction of stress . . . . .  $U = 0.90$
- b. W, M or S shapes not meeting the conditions of Subparagraph a, structural tees cut from these shapes and all other shapes, including built-up cross sections. Bolted or riveted connections shall have no fewer than three fasteners per line in the direction of stress . . . . .  $U = 0.85$
- c. All members with bolted or riveted connections having only two fasteners per line in the direction of stress . . . . .  $U = 0.75$

When load is transmitted by transverse welds to some but not all of the cross-sectional elements of W, M or S shapes and structural tees cut from these shapes,  $A_e$ , shall be taken as the area of the directly connected elements.

When the load is transmitted to a plate by longitudinal welds along both edges at the end of the plate, the length of the welds shall not be less than the width of the plate. The effective net area,  $A_e$ , shall be computed by Equation (B3-2).

Unless a larger coefficient can be justified by tests or other criteria, the following values of  $U$  shall be used:

- a. When  $l > 2w$  .....  $U = 1.0$
- b. When  $2w > l > 1.5w$  .....  $U = 0.87$
- c. When  $1.5w > l > w$  .....  $U = 0.75$

**WHERE:**

- $l$  = weld length, in. (mm)
- $w$  = plate width (distance between welds), in. (mm)

Bolted and riveted splice and gusset plates and other connection fittings subject to tensile force shall be designed in accordance with the provisions of Section D1, where the effective net area shall be taken as the actual net area, except that, for the purpose of design calculations, it shall not be taken as greater than 85 percent of the gross area.

**B4. STABILITY**

General stability shall be provided for the structure as a whole and for each compression element.

Consideration shall be given to significant load effects resulting from the deflected shape of the structure or of individual elements of the lateral load resisting system, including effects on beams, columns, bracing, connections and shear walls.

**B5. LOCAL BUCKLING**

**1. Classification of Steel Sections.** Steel sections are classified as compact, noncompact and slender element sections. For a section to qualify as compact, its flanges must be continuously connected to the web or webs and the width-thickness ratios of its compression elements must not exceed the applicable limiting width-thickness ratios from Table B5.1. Steel sections that do not qualify as compact are classified as noncompact if the width-thickness ratios of the compression elements do not exceed the values shown for noncompact in Table B5.1. If the width-thickness ratios of any compression element exceed the latter applicable value, the section is classified as a slender element section.

For unstiffened elements which are supported along only one edge, parallel to the direction of the compression force, the width shall be taken as follows:

- a. For flanges of I-shaped members and tees, the width  $b$  is half the full nominal width.
- b. For legs of angles and flanges of channels and zees, the width  $b$  is the full nominal dimension.
- c. For plates, the width  $b$  is the distance from the free edge to the first row of fasteners or line of welds.
- d. For stems of tees,  $d$  is taken as the full nominal depth.

For stiffened elements, i.e., supported along two edges parallel to the direction of the compression force, the width shall be taken as follows:

- a. For webs of rolled, built-up or formed sections,  $h$  is the clear distance between flanges.
- b. For webs of rolled, built-up or formed sections,  $d$  is the full nominal depth.
- c. For flange or diaphragm plates in built-up sections, the width  $b$  is the distance between adjacent lines of fasteners or lines of welds.
- d. For flanges of rectangular hollow structural sections, the width  $b$  is the clear distance between webs less the inside corner radius on each side. If the corner radius is not known, the flat width may be taken as the total section width minus three times the thickness.

For tapered flanges of rolled sections, the thickness is the nominal value halfway between the free edge and the corresponding face of the web.

**2. Slender Compression Elements.** For the design of flexural and compressive sections with slender compressive elements, see Appendix B5.

### **B6. ROTATIONAL RESTRAINT AT POINTS OF SUPPORT**

At points of support, beams, girders and trusses shall be restrained against rotation about their longitudinal axis.

### **B7. LIMITING SLENDERNESS RATIOS**

For members whose design is based on compressive force, the slenderness ratio  $Kl/r$  preferably should not exceed 200. If this limit is exceeded, the allowable stress shall not exceed the value obtained from Equation (E2-2).

For members whose design is based on tensile force, the slenderness ratio  $L/r$  preferably should not exceed 300. The above limitation does not apply to rods in tension. Members which have been designed to perform as tension members in a structural system, but experience some compression loading, need not satisfy the compression slenderness limit.

### **B8. SIMPLE SPANS**

Beams, girders and trusses designed on the basis of simple spans shall have an effective length equal to the distance between centers of gravity of the members to which they deliver their end reactions.

### **B9. END RESTRAINT**

When designed on the assumption of full or partial end restraint due to continuous, semi-continuous or cantilever action, the beams, girders and trusses, as well as the sections of the members to which they connect, shall be designed to carry the shears and moments so introduced, as well as all other forces, without exceeding at any point the unit stresses prescribed in Chapters D through F, except that some nonelastic but self-limiting deformation of a part of the connection is permitted when this is essential to avoid overstressing of fasteners.

TABLE B5.1  
Limiting Width-Thickness Ratios  
for Compression Elements

Description of Element	Width-Thickness Ratio	Limiting Width-Thickness Ratios	
		Compact <sup>c</sup>	Noncompact <sup>c</sup>
Flanges of I-shaped rolled beams and channels in flexure <sup>a</sup>	$b/t$	$65/\sqrt{F_y}$	$95/\sqrt{F_y}$
Flanges of I-shaped welded beams in flexure	$b/t$	$65/\sqrt{F_y}$	$95/\sqrt{F_y/k_c^e}$
Outstanding legs of pairs of angles in continuous contact; angles or plates projecting from rolled beams or columns; stiffeners on plate girders	$b/t$	NA	$95/\sqrt{F_y}$
Angles or plates projecting from girders, built-up columns or other compression members; compression flanges of plate girders	$b/t$	NA	$95/\sqrt{F_y/k_c}$
Stems of tees	$d/t$	NA	$127/\sqrt{F_y}$
Unstiffened elements simply supported along one edge, such as legs of single-angle struts, legs of double-angle struts with separators and cross or star-shaped cross sections	$b/t$	NA	$76/\sqrt{F_y}$
Flanges of square and rectangular box and hollow structural sections of uniform thickness subject to bending or compression <sup>d</sup> ; flange cover plates and diaphragm plates between lines of fasteners or welds	$b/t$	$190/\sqrt{F_y}$	$238/\sqrt{F_y}$
Unsupported width of cover plates perforated with a succession of access holes <sup>b</sup>	$b/t$	NA	$317/\sqrt{F_y}$
All other uniformly compressed stiffened elements, i.e., supported along two edges	$b/t$ $h/t_w$	NA	$253/\sqrt{F_y}$
Webs in flexural compression <sup>a</sup>	$d/t$	$640/\sqrt{F_y}$	—
	$h/t_w$	—	$760/\sqrt{F_b}$
Webs in combined flexural and axial compression	$d/t_w$	for $f_a/F_y \leq 0.16$ $\frac{640}{\sqrt{F_y}} \left( 1 - 3.74 \frac{f_a}{F_y} \right)$	—
		for $f_a/F_y > 0.16$ $257/\sqrt{F_y}$	
	$h/t_w$	—	$760/\sqrt{F_b}$
Circular hollow sections In axial compression In flexure	$D/t$	$3,300/F_y$ $3,300/F_y$	— —

<sup>a</sup>For hybrid beams, use the yield strength of the flange  $F_{yf}$  instead of  $F_y$ .  
<sup>b</sup>Assumes net area of plate at widest hole.  
<sup>c</sup>For design of slender sections that exceed the noncompact limits see Appendix B5.  
<sup>d</sup>See also Sect. F3.1.  
<sup>e</sup> $k_c = \frac{4.05}{(h/\eta)^{0.46}}$  if  $h/t > 70$ , otherwise  $k_c = 1.0$ .

NOTE: See next page for metric conversions.

TABLE B5.1  
Limiting Width-Thickness Ratios  
for Compression Elements

Description of Element	Width-Thickness Ratio	Limiting Width-Thickness Ratios	
		Compact	Noncompact <sup>c</sup>
Flanges of I-shaped rolled beams and channels in flexure <sup>a</sup>	$b/t$	$0.38 \sqrt{\frac{E}{F_y}}^c$	$0.56 \sqrt{\frac{E}{F_y}}$
Flanges of I-shaped welded beams in flexure	$b/t$	$0.38 \sqrt{\frac{E}{F_y}}^c$	$\left(0.56 \sqrt{\frac{E}{F_y/k_c}}\right)^c$
Outstanding legs of pairs of angles in continuous contact; angles or plates projecting from rolled beams or columns; stiffeners on plate girders	$b/t$	NA	$0.56 \sqrt{\frac{E}{F_y}}$
Angles or plates projecting from girders, built-up columns or other compression members; compression flanges of plate girders	$b/t$	NA	$0.75 \sqrt{\frac{E}{F_y}}$
Stems of tees	$d/t$	NA	$0.75 \sqrt{\frac{E}{F_y}}$
Unstiffened elements simply supported along one edge, such as legs of single-angle struts, legs of double-angle struts with separators and cross or star-shaped cross sections	$b/t$	NA	$0.45 \sqrt{\frac{E}{F_y}}$
Flanges of square and rectangular box and hollow structural sections of uniform thickness subject to bending or compression <sup>d</sup> ; flange cover plates and diaphragm plates between lines of fasteners or welds	$b/t$	$1.12 \sqrt{\frac{E}{F_y}}$	$1.40 \sqrt{\frac{E}{F_y}}$
Unsupported width of cover plates perforated with a succession of access holes <sup>d</sup>	$b/t$	NA	$1.86 \sqrt{\frac{E}{F_y}}$
All other uniformly compressed stiffened elements, i.e., supported along two edges	$b/t$ $h/t_w$	NA	$1.49 \sqrt{\frac{E}{F_y}}$
Webs in flexural compression <sup>a</sup>	$d/t$	$3.76 \sqrt{\frac{E}{F_y}}$	—
	$h/t_w$	—	$4.47 \sqrt{\frac{E}{F_y}}$
Webs in combined flexural and axial compression	$d/t_w$	for $f_a/F_y \leq 0.16$ $3.76 \sqrt{\frac{E}{F_y}} \left(1 - 3.74 \frac{f_a}{F_y}\right)$	—
		for $f_a/F_y > 0.16$ $1.51 \sqrt{\frac{E}{F_y}}$	
	$h/t_w$	—	$4.47 \sqrt{\frac{E}{F_y}}$

(Continued)

**TABLE B5.1**  
**Limiting Width-Thickness Ratios**  
**for Compression Elements—(Continued)**

Circular hollow sections In axial compression	$D/t$	$0.11 \frac{E}{F}$	—
In flexure		$0.11 \frac{E}{F}$	—
<sup>a</sup> For hybrid beams, use the yield strength of the flange $F_{yf}$ instead of $F_y$ . <sup>b</sup> Assumes net area of plate at widest hole. <sup>c</sup> For design of slender sections that exceed the noncompact limits see Appendix B5. <sup>d</sup> See also Sect. F3.1. <sup>e</sup> $k_c = \frac{4.05}{(h/t)^{0.46}}$ if $h/t > 70$ , otherwise $k_c = 1.0$ .			

### B10. PROPORTIONS OF BEAMS AND GIRDERS

Rolled or welded shapes, plate girders and cover-plated beams shall, in general, be proportioned by the moment of inertia of the gross section. No deduction shall be made for shop or field bolt or rivet holes in either flange provided that

$$0.5F_u A_{fn} \geq 0.6F_y A_{fg} \quad (\text{B10-1})$$

where  $A_{fg}$  is the gross flange area and  $A_{fn}$  is the net flange area, calculated in accordance with the provisions of Sections B1 and B2.

If

$$0.5F_u A_{fn} < 0.6F_y A_{fg} \quad (\text{B10-2})$$

the member flexural properties shall be based on an effective tension flange area,  $A_{fe}$ :

$$A_{fe} = \frac{5}{6} \left( \frac{F_u}{F_y} \right) A_{fn} \quad (\text{B10-3})$$

Hybrid girders may be proportioned by the moment of inertia of their gross section\*, subject to the applicable provisions in Section G1, provided they are not required to resist an axial force greater than  $0.15F_y$  times the area of the gross section, where  $F_y$  is the yield stress of the flange material. To qualify as hybrid girders, the flanges at any given section shall have the same cross-sectional area and be made of the same grade of steel.

Flanges of welded beams or girders may be varied in thickness or width by splicing a series of plates or by the use of cover plates.

The total cross-sectional area of cover plates of bolted or riveted girders shall not exceed 70 percent of the total flange area.

High-strength bolts, rivets or welds connecting flange to web, or cover plate to flange, shall be proportioned to resist the total horizontal shear resulting from the bending forces on the girder. The longitudinal distribution of these bolts, rivets or intermittent welds shall be in proportion to the intensity of the shear. However, the longitudinal spacing shall not exceed the maximum permitted for compression or tension members in Section D2 or E4, respectively. Bolts, rivets or welds connecting flange to web shall also be proportioned to transmit to the web any loads applied directly to the flange, unless provision is made to transmit such loads by direct bearing.

Partial length cover plates shall be extended beyond the theoretical cutoff point and the extended portion shall be attached to the beam or girder by high-strength bolts in a slip-critical connection, rivets or fillet welds adequate, at the applicable stresses allowed in Sections J2.4, J3.4, or K4, to develop the cover plate's portion of the flexural stresses in the beam or girder at the theoretical cutoff point.

\*No limit is placed on the web stresses produced by the applied bending moment for which a hybrid girder is designed, except as provided in Section K4 and Appendix K4.

In addition, for welded cover plates, the welds connecting the cover plate termination to the beam or girder in the length  $a'$ , defined below, shall be adequate, at the allowed stresses, to develop the cover plate's portion of the flexural stresses in the beam or girder at the distance  $a'$  from the end of the cover plate. The length  $a'$ , measured from the end of the cover plate, shall be:

1. A distance equal to the width of the cover plate when there is a continuous weld equal to or larger than three fourths of the plate thickness across the end of the plate and continuous welds along both edges of the cover plate in the length  $a'$ .

2. A distance equal to  $1\frac{1}{2}$  times the width of the cover plate when there is a continuous weld smaller than three fourths of the plate thickness across the end of the plate and continuous welds along both edges of the cover plate in the length  $a'$ .

3. A distance equal to 2 times the width of the cover plate when there is no weld across the end of the plate, but continuous welds along both edges of the cover plate in the length  $a'$ .

### B11. PROPORTIONING OF CRANE GIRDERS

The flanges of plate girders supporting cranes or other moving loads shall be proportioned to resist the horizontal forces produced by such loads.

## CHAPTER C

### FRAMES AND OTHER STRUCTURES

This chapter specifies general requirements to assure stability of the structure as a whole.

#### C1. GENERAL

In addition to meeting the requirements of member strength and stiffness, frames and other continuous structures shall be designed to provide the needed deformation capacity and to assure overall frame stability.

#### C2. FRAME STABILITY

1. **Braced Frames.** In trusses and in those frames where lateral stability is provided by adequate attachment to diagonal bracing, to shear walls, to an adjacent structure having adequate lateral stability or to floor slabs or roof decks secured horizontally by walls or bracing systems parallel to the plane of the frame, the effective length factor  $K$  for the compression members shall be taken as unity, unless analysis shows that a small value is permitted.

2. **Unbraced Frames.** In frames where lateral stability is dependent upon the bending stiffness of rigidly connected beams and columns, the effective length  $Kl$  of compression members shall be determined by analysis and shall not be less than the actual unbraced length.

## CHAPTER D

### TENSION MEMBERS

This section applies to prismatic members subject to axial tension caused by forces acting through the centroidal axis. For members subject to combined axial tension and flexure, see Section H2. For members subject to fatigue, see Section K4. For tapered members, see Appendix F7. For threaded rods, see Section J3.

#### D1. ALLOWABLE STRESS

The allowable stress  $F_t$  shall not exceed  $0.60F_y$  on the gross area nor  $0.50F_u$  on the effective net area. In addition, pin-connected members shall meet the requirements of Section D3.1 at the pin hole.

Block shear strength shall be checked at end connections of tension members in accordance with Section J4.

Eyebars shall meet the requirements of Section D3.1.

## D2. BUILT-UP MEMBERS

The longitudinal spacing of connectors between elements in continuous contact consisting of a plate and a shape or two plates shall not exceed:

24 times the thickness of the thinner plate, or 12 inches (305 mm) for painted members or unpainted members not subject to corrosion.

14 times the thickness of the thinner plate, or 7 inches (178 mm) for unpainted members of weathering steel subject to atmospheric corrosion.

In a tension member the longitudinal spacing of fasteners and intermittent welds connecting two or more shapes in contact shall not exceed 24 inches (610 mm). Tension members composed of two or more shapes or plates separated by intermittent fillers shall be connected to one another at these fillers at intervals such that the slenderness ratio of either component between the fasteners does not exceed 300.

Either perforated cover plates or tie plates without lacing are permitted on the open sides of built-up tension members. Tie plates shall have a length of not less than two thirds the distance between the lines of welds or fasteners connecting them to the components of the member. The thickness of such tie plates shall not be less than one fiftieth of the distance between these lines. The longitudinal spacing of intermittent welds or fasteners at tie plates shall not exceed 6 inches (152 mm).

The spacing of tie plates shall be such that the slenderness ratio of any component in the length between tie plates should preferably not exceed 300.

## D3. PIN-CONNECTED MEMBERS

**1. Allowable Stress.** The allowable stress on the net area of the pinhole for pin-connected members is  $0.45 F_y$ . The bearing stress on the projected area of the pin shall not exceed the stress allowed in Section J8.

The allowable stress on eyebars meeting the requirements of Section D3.3 is  $0.60F_y$  on the body area.

**2. Pin-connected Plates.** The minimum net area beyond the pinhole, parallel to the axis of the member, shall not be less than two thirds of the net area across the pinhole.

The distance used in calculations, transverse to the axis of pin-connected plates or any individual element of a built-up member, from the edge of the pinhole to the edge of the member or element shall not exceed 4 times the thickness at the pin-hole. For calculation purposes, the distance from the edge of the pinhole to the edge of the plate or to the edge of a separated element of a built-up member at the pinhole, shall not be assumed to be more than 1.25 times the diameter of the pinhole.

For pin-connected members in which the pin is expected to provide for relative movement between connected parts while under full load, the diameter of the pin-hole shall not be more than  $1/32$  inch (0.8 mm) greater than the diameter of the pin.

The corners beyond the pinhole may be cut at  $45^\circ$  to the axis of the member, provided the net area beyond the pinhole, on a plane perpendicular to the cut, is not less than that perpendicular to the direction of the applied load.

**3. Eyebars.** Eyebars shall be of uniform thickness, without reinforcement at the pinholes, and have circular heads whose periphery is concentric with the pinhole. The radius of the transition between the circular head and the eyebar body shall not be less than the diameter of the head.

For calculation purposes, the width of the body of an eyebar shall not exceed eight times its thickness.

The thickness may be less than  $1/2$  inch (13 mm) only if external nuts are provided to tighten pin plates and filler plates into snug contact. For calculation purposes, the distance from the hole edge

to plate edge perpendicular to the direction of the applied load shall not be less than two thirds or greater than three fourths times the width of the eyebar body.

The pin diameter shall not be less than seven eighths times the eyebar width.

The pinhole diameter shall be no more than  $1/32$ -inch (0.8 mm) greater than the pin diameter.

For steel having a yield stress greater than 70 ksi (483 N/mm<sup>2</sup>), the hole diameter shall not exceed 5 times the plate thickness and the width of the eyebar shall be reduced accordingly.

## CHAPTER E

### COLUMNS AND OTHER COMPRESSION MEMBERS

This section applies to prismatic members with compact and noncompact sections subject to axial compression through the centroidal axis. For members with slender elements, see Appendix B5.2. For members subject to combined axial compression and flexure, see Chapter H. For tapered members, see Appendix F7.

#### E1. EFFECTIVE LENGTH AND SLENDERNESS RATIO

The effective-length factor  $K$  shall be determined in accordance with Section C2.

In determining the slenderness ratio of an axially loaded compression member, the length shall be taken as its effective length  $Kl$  and  $r$  as the corresponding radius of gyration. For limiting slenderness ratios, see Section B7.

#### E2. ALLOWABLE STRESS

On the gross section of axially loaded compression members whose cross sections meet the provisions of Table B5.1, when  $Kl/r$ , the largest effective slenderness ratio of any unbraced segment is less than  $C_c$ , the allowable stress is:

$$F_a = \frac{\left[ 1 - \frac{(Kl/r)^2}{2C_c^2} \right] F_y}{\frac{5}{3} + \frac{3(Kl/r)}{8C_c} - \frac{(Kl/r)^3}{8C_c^3}} \quad (\text{E2-1})$$

WHERE

$$C_c = \sqrt{\frac{2\pi^2 E}{F_y}}$$

On the gross section of axially loaded compression members, when  $Kl/r$  exceeds  $C_c$ , the allowable stress is:

$$F_a = \frac{12\pi^2 E}{23(Kl/r)^2} \quad (\text{E2-2})$$

#### E3. FLEXURAL-TORSIONAL BUCKLING

Singly symmetric and unsymmetric columns, such as angles or tee-shaped columns, and doubly symmetric columns such as cruciform or built-up columns with very thin walls, may require consideration of flexural-torsional and torsional buckling.

#### E4. BUILT-UP MEMBERS

All parts of built-up compression members and the transverse spacing of their lines of fasteners shall meet the requirements of Section B7.

For spacing and edge distance requirements for weathering steel members, see Section J3.10.

At the ends of built-up compression members bearing on base plates or milled surfaces, all components in contact with one another shall be connected by rivets or bolts spaced longitudinally not more than four diameters apart for a distance equal to one and one-half times the maximum width of the member, or by continuous welds having a length not less than the maximum width of the member.

The longitudinal spacing for intermediate bolts, rivets or intermittent welds in built-up members shall be adequate to provide for the transfer of calculated stress. The maximum longitudinal spacing of bolts, rivets or intermittent welds connecting two rolled shapes in contact shall not exceed 24 inches (610 mm). In addition, for painted members and unpainted members not subject to corrosion where the outside component consists of a plate, the maximum longitudinal spacing shall not exceed:

$127/\sqrt{F_y}$  (For SI:  $0.75\sqrt{E/F_y}$ ) times the thickness of the outside plate or 12 inches (305 mm) when fasteners are not staggered along adjacent gage lines.

$190/\sqrt{F_y}$  (For SI:  $1.12\sqrt{E/F_y}$ ) times the thickness of the outside plate or 13 inches when fasteners are staggered along adjacent gage lines.

Compression members composed of two or more rolled shapes separated by intermittent fillers shall be connected at these fillers at intervals such that the slenderness ratio  $Kl/r$  of either shape, between the fasteners, does not exceed three fourths times the governing slenderness ratio of the built-up member. The least radius of gyration  $r$  shall be used in computing the slenderness ratio of each component part. At least two intermediate connectors shall be used along the length of the built-up member.

All connections, including those at the ends, shall be welded or shall utilize high-strength bolts tightened to the requirements of Table J3.7.

Open sides of compression members built up from plates or shapes shall be provided with lacing having tie plates at each end and at intermediate points if the lacing is interrupted. Tie plates shall be as near the ends as practicable. In main members carrying calculated stress, the end tie plates shall have a length of not less than the distance between the lines of fasteners or welds connecting them to the components of the member. Intermediate tie plates shall have a length not less than one half of this distance. The thickness of tie plates shall not be less than one fiftieth of the distance between the lines of fasteners or welds connecting them to the components of the member. In bolted and riveted construction, the spacing in the direction of stress in tie plates shall not be more than 6 diameters and the tie plates shall be connected to each component by at least 3 fasteners. In welded construction, the welding on each line connecting a tie plate shall aggregate not less than one third the length of the plate.

Lacing, including flat bars, angles, channels or other shapes employed as lacing, shall be so spaced that the ratio  $l/r$  of the flange included between their connections shall not exceed three fourths times the governing ratio for the member as a whole. Lacing shall be proportioned to resist a shearing stress normal to the axis of the member equal to 2 percent of the total compressive stress in the member. The ratio  $l/r$  for lacing bars arranged in single systems shall not exceed 140. For double lacing this ratio shall not exceed 200. Double lacing bars shall be joined at their intersections. For lacing bars in compression the unsupported length of the lacing bar shall be taken as the distance between fasteners or welds connecting it to the components of the built-up member for single lacing, and 70 percent of that distance for double lacing. The inclination of lacing bars to the axis of the member shall preferably not be less than  $60^\circ$  for single lacing and  $45^\circ$  for double lacing. When the distance between the lines of fasteners or welds in the flanges is more than 15 inches (381 mm), the lacing preferably shall be double or be made of angles.

The function of tie plates and lacing may be performed by continuous cover plates perforated with access holes. The unsupported width of such plates at access holes, as defined in Section B5, is assumed available to resist axial stress, provided that: the width-to-thickness ratio conforms to the limitations of Section B5; the ratio of length (in direction of stress) to width of holes shall not exceed

2; the clear distance between holes in the direction of stress shall not be less than the transverse distance between nearest lines of connecting fasteners or welds; and the periphery of the holes at all points shall have a minimum radius of 1½ inches (38 mm).

#### E5. PIN-CONNECTED COMPRESSION MEMBERS

Pin connections of pin-connected compression members shall conform to the requirements of Section D3.

#### E6. COLUMN WEB SHEAR

Column connections must be investigated for concentrated force introduction in accordance with Section K1.

### CHAPTER F

#### BEAMS AND OTHER FLEXURAL MEMBERS

Beams shall be distinguished from plate girders on the basis of the web slenderness ratio  $h/t_w$ . When this value is greater than  $760/\sqrt{F_y}$  (For SI:  $4.47\sqrt{E/F_y}$ ) the allowable bending stress is given in Chapter G. The allowable shear stresses and stiffener requirements are given in Chapter F unless tension field action is used, then the allowable shear stresses are given in Chapter G.

This chapter applies to singly or doubly symmetric beams including hybrid beams and girders loaded in the plane of symmetry. It also applies to channels loaded in a plane passing through the shear center parallel to the web or restrained against twisting at load points and points of support. For members subject to combined flexural and axial force, see Section H1.

#### F1. ALLOWABLE STRESS: STRONG AXIS BENDING OF I-SHAPED MEMBERS AND CHANNELS

**1. Members with Compact Sections.** For members with compact sections as defined in Section B5.1 [excluding hybrid beams and members with yield points greater than 65 ksi (448 N/mm<sup>2</sup>)] symmetrical about, and loaded in, the plane of their minor axis the allowable stress is

$$F_b = 0.66F_y \quad (\text{F1-1})$$

provided the flanges are connected continuously to the web or webs and the laterally unsupported length of the compression flange  $L_b$  does not exceed the value of  $L_c$ , as given by the smaller of:

$$\frac{76b_f}{\sqrt{F_y}} \text{ or } \frac{20,000}{(d/A_f)F_y} \quad (\text{F1-2})$$

For SI: 
$$0.45b_f \sqrt{\frac{E}{F_y}} \text{ or } \frac{0.69E}{(d/A_f)F_y}$$

Members [including composite members and excluding hybrid members and members with yield points greater than 65 ksi (448 N/mm<sup>2</sup>)] which meet the requirements for compact sections and are continuous over supports or rigidly framed to columns, may be proportioned for nine tenths of the negative moments produced by gravity loading when such moments are maximum at points of support, provided that, for such members, the maximum positive moment is increased by one-tenth of the average negative moments. This reduction shall not apply to moments produced by loading on cantilevers. If the negative moment is resisted by a column rigidly framed to the beam or girder, the one-tenth reduction is permitted in proportioning the column for the combined axial and bending loading, provided that the stress  $f_a$  due to any concurrent axial load on the member, does not exceed  $0.15F_a$ .

**2. Members with Noncompact Sections.** For members meeting the requirements of Section F1.1 except that their flanges are noncompact [excluding built-up members and members with yield points greater than 65 ksi (448 N/mm<sup>2</sup>)], the allowable stress is

$$F_b = F_y \left[ 0.79 - 0.002 \frac{b_f}{2t_f} \sqrt{F_y} \right] \quad (\text{F1-3})$$

For SI:

$$F_b = F_y \left[ 0.79 - 0.34 \left( \frac{b_f}{2t_f} \right) \sqrt{\frac{F_y}{E}} \right]$$

For built-up members meeting the requirements of Section F1.1 except that their flanges are noncompact and their webs are compact or noncompact [excluding hybrid girders and members with yield points greater than 65 ksi (448 N/mm<sup>2</sup>)], the allowable stress is

$$F_b = F_y \left[ 0.79 - 0.002 \frac{b_f}{2t_f} \sqrt{\frac{F_y}{k_c}} \right] \quad (\text{F1-4})$$

For SI:

$$F_b = F_y \left[ 0.79 - 0.34 \left( \frac{b_f}{2t_f} \right) \sqrt{\frac{F_y}{Ek_c}} \right]$$

WHERE:

$$k_c = \frac{4.05}{(h/t_w)^{0.46}} \text{ if } h/t_w > 70, \text{ otherwise } k_c = 1.0.$$

For members with a noncompact section (Section B5), but not included above, and loaded through the shear center and braced laterally in the region of compression stress at intervals not exceeding  $76b_f/\sqrt{F_y}$  (For SI:  $0.45b_f/\sqrt{E/F_y}$ ), the allowable stress is

$$F_b = 0.60F_y \quad (\text{F1-5})$$

**3. Members with Compact or Noncompact Sections with Unbraced Length Greater than  $L_c$ .** For flexural members with compact or noncompact sections as defined in Section B5.1, and with unbraced lengths greater than  $L_c$  as defined in Section F1.1, the allowable bending stress in tension is determined from Equation (F1-5).

For such members with an axis of symmetry in, and loaded in the plane of their web, the allowable bending stress in compression is determined as the larger value from Equations (F1-6) or (F1-7) and (F1-8), except that Equation (F1-8) is applicable only to sections with a compression flange that is solid and approximately rectangular in cross section and that has an area not less than the tension flange. Higher values of the allowable compressive stress are permitted if justified by a more precise analysis. Stresses shall not exceed those permitted by Chapter G, if applicable.

For channels bent about their major axis, the allowable compressive stress is determined from Equation (F1-8).

When

$$\sqrt{\frac{102 \times 10^3 C_b}{F_y}} \leq \frac{l}{r_T} \leq \sqrt{\frac{510 \times 10^3 C_b}{F_y}} :$$

For SI:

$$\sqrt{\frac{3.52EC_b}{F_y}} \leq \frac{l}{r_T} \leq \sqrt{\frac{17.59EC_b}{F_y}} :$$

$$F_b = \left[ \frac{2}{3} - \frac{F_y(l/r_T)^2}{1530 \times 10^3 C_b} \right] F_y \leq 0.60F_y \quad (\text{F1-6})$$

$$\text{For SI: } F_b = \left[ \frac{2}{3} - \frac{F_y(l/r_T)^2}{52.75EC_b} \right] F_y \leq 0.60F_y$$

When

$$\frac{l}{r_T} \geq \sqrt{\frac{510 \times 10^3 C_b}{F_y}}$$

$$\text{For SI: } \frac{l}{r_T} \geq \sqrt{\frac{17.59EC_b}{F_y}}$$

$$F_b = \frac{170 \times 10^3 C_b}{(l/r_T)^2} \leq 0.60F_y \quad (\text{F1-7})$$

$$\text{For SI: } F_b = \frac{5.86EC_b}{(l/r_T)^2} \leq 0.60F_y$$

For any value of  $l/r_T$ :

$$F_b = \frac{12 \times 10^3 C_b}{ld/A_f} \leq 0.60F_y \quad (\text{F1-8})$$

$$\text{For SI: } F_b = \frac{0.41EC_b}{ld/A_f} \leq 0.60F_y$$

**WHERE:**

- $l$  = distance between cross sections braced against twist or lateral displacement of the compression flange, in. (mm). For cantilevers braced against twist only at the support,  $l$  may conservatively be taken as the actual length.
- $r_T$  = radius of gyration of a section comprising the compression flange plus one third of the compression web area, taken about an axis in the plane of the web, in. (mm).
- $A_f$  = area of the compression flange, in.<sup>2</sup> (mm<sup>2</sup>)
- $C_b$  =  $1.75 + 1.05 (M_1/M_2) + 0.3 (M_1/M_2)^2$ , but not more than 2.3\*, where  $M_1$  is the smaller and  $M_2$  the larger bending moment at the ends of the unbraced length, taken about the strong axis of the member, and where  $M_1/M_2$  the ratio of end moments, is positive when  $M_1$  and  $M_2$  have the same sign (reverse curvature bending) and negative when they are of opposite signs (single curvature bending). When the bending moment at any point within an unbraced length is larger than that at both ends of this length, the value of  $C_b$  shall be taken as unity. When computing  $F_{bx}$  to be used in Equation (H1-1),  $C_b$  may be computed by the equation given above for frames subject to joint translation, and it shall be taken as unity for frames braced against joint translation.  $C_b$  may conservatively be taken as unity for cantilever beams.

For hybrid plate girders,  $F_y$  for Equations (F1-6) and (F1-7) is the yield stress of the compression flange. Equation (F1-8) shall not apply to hybrid girders.

Section F1.3 does not apply to tee sections if the stem is in compression anywhere along the unbraced length.

---

\*It is conservative to take  $C_b$  as unity. For values smaller than 2.3, see Table 6 in the Numerical Values Section.

**F2. ALLOWABLE STRESS: WEAK AXIS BENDING OF I-SHAPED MEMBERS, SOLID BARS AND RECTANGULAR PLATES**

Lateral bracing is not required for members loaded through the shear center about their weak axis or for members of equal strength about both axes.

**1. Members with Compact Sections.** For doubly symmetrical I- and H-shape members with compact flanges (Section B5) continuously connected to the web and bent about their weak axes (except members with yield points greater than 65 ksi); solid round and square bars; and solid rectangular sections bent about their weaker axes, the allowable stress is

$$F_b = 0.75 F_y \quad (\text{F2-1})$$

**2. Members with Noncompact Sections.** For members not meeting the requirements for compact sections of Section B5 and not covered in Section F3, bent about their minor axis, the allowable stress is

$$F_b = 0.60 F_y \quad (\text{F2-2})$$

Doubly symmetrical I- and H-shape members bent about their weak axes (except members with yield points greater than 65 ksi) with noncompact flanges (Section B5) continuously connected to the web may be designed on the basis of an allowable stress of

$$F_b = F_y \left[ 1.075 - 0.005 \left( \frac{b_f}{2t_f} \right) \sqrt{F_y} \right] \quad (\text{F2-3})$$

$$\text{For SI:} \quad F_b = F_y \left[ 1.075 - 0.85 \left( \frac{b_f}{2t_f} \right) \sqrt{\frac{F_y}{E}} \right]$$

**F3. ALLOWABLE STRESS: BENDING OF BOX MEMBERS, RECTANGULAR TUBES AND CIRCULAR TUBES**

**1. Members with Compact Sections.** For members bent about their strong or weak axes, members with compact sections as defined in Section B5 and flanges continuously connected to the webs, the allowable stress is

$$F_b = 0.66 F_y \quad (\text{F3-1})$$

To be classified as a compact section, a box-shaped member shall have, in addition to the requirements in Section B5, a depth not greater than six times the width, a flange thickness not greater than two times the web thickness and a laterally unsupported length  $L_b$  less than or equal to

$$L_c = \left( 1,950 + 1,200 \frac{M_1}{M_2} \right) \frac{b}{F_y} \quad (\text{F3-2})$$

$$\text{For SI:} \quad L_c = \left( 0.067 + 0.04 \frac{M_1}{M_2} \right) \frac{bE}{F_y}$$

except that it need not be less than  $1,200 (b/F_y)$ , where  $M_1$  is the smaller and  $M_2$  the larger bending moment at the ends of the unbraced length, taken about the strong axis of the member, and where  $M_1/M_2$ , the ratio of end moments, is positive when  $M_1$  and  $M_2$  have the same sign (reverse curvature bending) and negative when they are of opposite signs (single curvature bending).

**2. Members with Noncompact Sections.** For box-type and tubular flexural members that meet the noncompact section requirements of Section B5, the allowable stress is

$$F_b = 0.60 F_y \quad (\text{F3-3})$$

Lateral bracing is not required for a box section whose depth is less than 6 times its width. Lateral-support requirements for box sections of larger depth-to-width ratios must be determined by special analysis.

#### F4. ALLOWABLE SHEAR STRESS

For  $h/t_w \leq 380/\sqrt{F_y}$  (For SI:  $h/t_w \leq 2.24\sqrt{E/F_y}$ ), on the overall depth times the web thickness, the allowable shear stress is

$$F_v = 0.40F_y \quad (\text{F4-1})$$

For  $h/t_w \geq 380/\sqrt{F_y}$  (For SI:  $h/t_w \geq 2.24\sqrt{E/F_y}$ ) the allowable shear stress is on the clear distance between flanges times the web thickness:

$$F_v = \frac{F_y}{2.89} \quad (C_v) \leq 0.40 F_y$$

WHERE:

$$C_v = \frac{45,000k_v}{F_y(h/t_w)^2} \quad \left( \text{For SI: } \frac{1.5k_v E}{F_y(h/t_w)^2} \right) \quad \text{when } C_v \text{ is less than } 0.8$$

$$= \frac{190}{(h/t_w)} \sqrt{\frac{k_v}{F_y}} \quad \left( \text{For SI: } \frac{1.12}{(h/t_w)} \sqrt{\frac{k_v E}{F_y}} \right) \quad \text{when } C_v \text{ is more than } 0.8$$

$$k_v = 4.00 + \frac{5.34}{(a/h)^2} \quad \text{when } a/h \text{ is less than } 1.0$$

$$= 5.34 + \frac{4.00}{(a/h)^2} \quad \text{when } a/h \text{ is more than } 1.0$$

$t_w$  = thickness of web, in. (mm)

$a$  = clear distance between transverse stiffeners, in. (mm)

$h$  = clear distance between flanges at the section under investigation, in. (mm)

For shear rupture on coped beam end connections, see Section J4.

Maximum  $h/t_w$  limits are given in Chapter G.

An alternative design method for plate girders utilizing tension field action is given in Chapter G.

#### F5. TRANSVERSE STIFFENERS

Intermediate stiffeners are required when the ratio  $h/t_w$  is greater than 260 and the maximum web shear stress  $f_v$  is greater than that permitted by Equation (F4-2).

The spacing of intermediate stiffeners, when required, shall be such that the web shear stress will not exceed the value for  $F_v$  given by Equation (F4-2) or (G3-1), as applicable, and

$$\frac{a}{h} \leq \left[ \frac{260}{(h/t_w)} \right]^2 \text{ and } 3.0 \quad (\text{F5-1})$$

#### F6. BUILT-UP MEMBERS

Where two or more rolled beams or channels are used side-by-side to form a flexural member, they shall be connected together at intervals of not more than 5 feet. Through-bolts and separators are permitted, provided that, in beams having a depth of 12 inches or more, no fewer than two bolts shall be used at each separator location. When concentrated loads are carried from one beam to the other, or distributed between the beams, diaphragms having sufficient stiffness to distribute the load shall be riveted, bolted or welded between the beams.

**F1. WEB-TAPERED MEMBERS**

See Appendix F7.

**CHAPTER G****PLATE GIRDERS**

Plate girders shall be distinguished from beams on the basis of the web slenderness ratio  $h/t_w$ . When this value is greater than  $760/\sqrt{f_y}$  (For SI:  $4.47\sqrt{E/f_y}$ ), the provisions of this chapter shall apply for allowable bending stress, otherwise Chapter F is applicable.

For allowable shear stress and transverse stiffener design, see appropriate sections in Chapter F or this chapter if tension field action is utilized.

**G1. WEB SLENDERNESS LIMITATIONS**

When no transverse stiffeners are provided or when transverse stiffeners are spaced more than one and one-half times the distance between flanges

$$\frac{h}{t_w} \leq \frac{14,000}{\sqrt{F_{yf}(F_{yf} + 16.5)}} \quad (\text{G1-1})$$

For SI: 
$$\frac{h}{t_w} \leq \frac{0.48E}{\sqrt{F_{yf}(F_{yf} + 113.7)}}$$

When transverse stiffeners are provided, spaced not more than one and one-half times the distance between flanges

$$\frac{h}{t_w} \leq \frac{2,000}{\sqrt{F_{yf}}} \quad (\text{G1-2})$$

For SI: 
$$\frac{h}{t_w} \leq 11.76 \sqrt{\frac{E}{F_{yf}}}$$

**G2. ALLOWABLE BENDING STRESS**

When the web depth-to-thickness ratio exceeds  $760/\sqrt{F_b}$  (For SI:  $4.47\sqrt{E/F_y}$ ), the maximum bending stress in the compression flange shall not exceed

$$F'_b \leq F_b R_{PG} R_e \quad (\text{G2-1})$$

**WHERE:**

$F_b$  = applicable bending stress given in Chapter F, ksi (N/mm<sup>2</sup>)

$$R_{PG} = 1 - 0.0005 \frac{A_w}{A_f} \left( \frac{h}{t} \frac{760}{\sqrt{F_b}} \right) \leq 1.0$$

For SI: 
$$R_{PG} = 1 - 0.0005 \frac{A_w}{A_f} \left( \frac{4.47h}{t} \sqrt{\frac{E}{F_y}} \right) \leq 1.0$$

$$R_e = \frac{12 + \left(\frac{A_w}{A_f}\right)(3\alpha - \alpha^3)}{12 + 2\left(\frac{A_w}{A_f}\right)} \leq 1.0$$

(nonhybrid girders,  $R_e = 1.0$ )

**WHERE:**

$A_w$  = area of web at the section under investigation, in.<sup>2</sup> (mm<sup>2</sup>)

$A_f$  = area of compression flange, in.<sup>2</sup> (mm<sup>2</sup>)

$\alpha = 0.6 F_{yw} / F_b \leq 1.0$

**G3. ALLOWABLE SHEAR STRESS WITH TENSION FIELD ACTION**

Except as herein provided, the largest average web shear,  $f_v$  in kips per square inch (N/mm<sup>2</sup>), computed for any condition of complete or partial loading, shall not exceed the value given by Equation (F4-2).

Alternatively, for girders other than hybrid girders, if intermediate stiffeners are provided and spaced to satisfy the provisions of Section G4 and if  $C_v \leq 1$ , the allowable shear including tension field action given by Equation (G3-1) is permitted in lieu of the value given by Equation (F4-2).

$$F_v = \frac{F_y}{2.89} \left[ C_v + \frac{1 - C_v}{1.15 \sqrt{1 + (a/h)^2}} \right] \leq 0.40F_y \quad (G3-1)^*$$

**G4. TRANSVERSE STIFFENERS**

Transverse stiffeners shall meet the requirements of Section F5.

In girders designed on the basis of tension field action, the spacing between stiffeners at end panels, at panels containing large holes, and at panels adjacent to panels containing large holes shall be such that  $f_v$  does not exceed the value given by Equation (F4-2).

Bolts and rivets connecting stiffeners to the girder web shall be spaced not more than 12 inches (305 mm) on center. If intermittent fillet welds are used, the clear distance between welds shall not be more than 16 times the web thickness or more than 10 inches (254 mm).

The moment of inertia,  $I_{st}$ , of a pair of intermediate stiffeners, or a single intermediate stiffener, with reference to an axis in the plane of the web, shall be limited as follows:

$$I_{st} \geq \left(\frac{h}{50}\right)^4 \quad (G4-1)$$

The gross area (total area, when stiffeners are furnished in pairs), in square inches (mm<sup>2</sup>), of intermediate stiffeners spaced as required for Equation (G3-1) shall not be less than

$$A_{st} = \frac{1 - C_v}{2} \left[ \frac{a}{h} - \frac{(a/h)^2}{\sqrt{1 + (a/h)^2}} \right] YDht \quad (G4-2)$$

When the greatest shear stress  $f_v$  in a panel is less than that permitted by Equation (G3-1), the reduction of this gross area requirement is permitted in like proportion.

Intermediate stiffeners required by Equation (G3-1) shall be connected for a total shear transfer, in kips per linear inch (N/mm) of single stiffener or pair of stiffeners, not less than

\*Equation (G3-1) recognizes the contribution of tension field action.

$$f_{vs} = h \sqrt{\left(\frac{F_y}{340}\right)^3} \quad (G4-3)$$

For SI:  $\times 6.89$  for N/mm<sup>2</sup>

where  $F_y$  = yield stress of web steel.

This shear transfer may be reduced in the same proportion that the largest computed shear stress,  $f_v$ , in the adjacent panels is less than that permitted by Equation (G3-1). However, rivets and welds in intermediate stiffeners which are required to transmit to the web an applied concentrated load or reaction shall be proportioned for not less than the applied load or reaction.

Intermediate stiffeners may be stopped short of the tension flange, provided bearing is not needed to transmit a concentrated load or reaction. The weld by which intermediate stiffeners are attached to the web shall not be terminated closer than four times or more than six times the web thickness from the near toe of the web-to-flange weld. When single stiffeners are used, they shall be attached to the compression flange, if it consists of a rectangular plate, to resist any uplift tendency due to torsion in the plate. When lateral bracing is attached to a stiffener, or a pair of stiffeners, in turn, these shall be connected to the compression flange to transmit 1 percent of the total flange stress, unless the flange is composed only of angles.

#### G5. COMBINED SHEAR AND TENSION STRESS

Plate girder webs which depend upon tension field action, as provided in Equation (G3-1), shall be so proportioned that bending tensile stress, due to moment in the plane of the girder web, shall not exceed  $0.60F_y$  or

$$\left(0.825 - 0.375 \frac{f_v}{F_v}\right) F_y \quad (G5-1)$$

#### WHERE:

$f_v$  = computed average web shear stress (total shear divided by web area), ksi (N/mm<sup>2</sup>).

$F_y$  = allowable web shear stress according to Equation (G3-1), ksi (N/mm<sup>2</sup>).

The allowable shear stress in the webs of girders having flanges and webs with yield point greater than 65 ksi (448 N/mm<sup>2</sup>) shall not exceed the values given by Equation (F4-2) if the flexural stress in the flange  $f_b$  exceeds  $0.75F_b$ .

## CHAPTER H COMBINED STRESSES

The strength of members subjected to combined stresses shall be determined according to the provisions of this chapter.

This chapter pertains to doubly and singly symmetrical members only. See Chapter E for determination of  $F_a$  and Chapter F for determination of  $F_{bx}$  and  $F_{by}$ .

### H1. AXIAL COMPRESSION AND BENDING

Members subjected to both axial compression and bending stresses shall be proportioned to satisfy the following requirements:

$$\frac{f_a}{F_a} + \frac{C_{mx} f_{bx}}{\left(1 - \frac{f_a}{F_{ex}}\right) F_{bx}} + \frac{C_{my} f_{by}}{\left(1 - \frac{f_a}{F_{ey}}\right) F_{by}} \leq 1.0 \quad (H1-1)$$

$$\frac{f_a}{0.60F_y} + \frac{f_{bx}}{F_{bx}} + \frac{f_{by}}{F_{by}} \leq 1.0 \quad (H1-2)$$

When  $f_a/F_a \leq 0.15$ , Equation (H1-3) is permitted in lieu of Equations (H1-1) and (H1-2):

$$\frac{f_a}{F_a} + \frac{f_{bx}}{F_{bx}} + \frac{f_{by}}{F_{by}} \leq 1.0 \quad (\text{H1-3})$$

In Equations (H1-1), (H1-2) and (H1-3), the subscripts  $x$  and  $y$ , combined with subscripts  $b$ ,  $m$  and  $e$ , indicate the axis of bending about which a particular stress or design property applies, and

$F_a$  = axial compressive stress that would be permitted if axial force alone existed, ksi (N/mm<sup>2</sup>).

$F_b$  = compressive bending stress that would be permitted if bending moment alone existed, ksi (N/mm<sup>2</sup>).

$$F'_e = \frac{12 \pi^2 E}{23(Kl_b/r_b)^2}$$

= Euler stress divided by a factor of safety, ksi (N/mm<sup>2</sup>) (in the expression for  $F'_e$ ,  $l_b$  is the actual unbraced length *in the plane of bending* and  $r_b$  is the corresponding radius of gyration.  $K$  is the effective length factor *in the plane of bending*). As in the case of  $F_a$ ,  $F_b$  and  $F'_e$  may be increased one third in accordance with Section A5.2.

$f_a$  = computed axial stress, ksi (N/mm<sup>2</sup>).

$f_b$  = computed compressive bending stress at the point under consideration, ksi (N/mm<sup>2</sup>).

$C_m$  = Coefficient whose value shall be taken as follows:

a. For compression members in frames subject to joint translation (sidesway),  $C_m = 0.85$ .

b. For rotationally restrained compression members in frames braced against joint translation and not subject to transverse loading between their supports in the plane of bending,  $C_m = 0.6 - 0.4 (M_1/M_2)$

where  $M_1/M_2$  is the ratio of the smaller to larger moments at the ends of that portion of the member unbraced in the plane of bending under consideration.  $M_1/M_2$  is positive when the member is bent in reverse curvature, negative when bent in single curvature.

c. For compression members in frames braced against joint translation in the plane of loading and subjected to transverse loading between their supports, the value of  $C_m$  may be determined by an analysis. However, in lieu of such analysis, the following values are permitted:

i. For members whose ends are restrained against rotation in the plane of bending

$$C_m = 0.85$$

ii. For members whose ends are unrestrained against rotation in the plane of bending

$$C_m = 1.0$$

## H2. AXIAL TENSION AND BENDING

Members subject to both axial tension and bending stresses shall be proportioned at all points along their length to satisfy the following equation:

$$\frac{f_a}{F_t} + \frac{f_{bx}}{F_{bx}} + \frac{f_{by}}{F_{by}} \leq 1.0 \quad (\text{H2-1})$$

where  $f_b$  is the computed bending tensile stress,  $f_a$  is the computed axial tensile stress,  $F_b$  is the allowable bending stress and  $F_t$  is the governing allowable tensile stress defined in Section D1.

However, the computed bending compressive stress arising from an independent load source relative to the axial tension, taken above, shall not exceed the applicable value required in Chapter F.

## CHAPTER I

### COMPOSITE CONSTRUCTION

This chapter applies to steel beams supporting a reinforced concrete slab so interconnected that the beams and the slab act together to resist bending. Simple and continuous composite beams with

shear connectors and concrete encased beams, constructed with or without temporary shores, are included.

### 11. DEFINITION

Two cases of composite members are recognized: totally encased members which depend upon natural bond for interaction with the concrete, and those with shear connectors (mechanical anchorage to the slab) with the steel member not necessarily encased.

A beam totally encased in concrete cast integrally with the slab may be assumed to be connected to the concrete by natural bond, without additional anchorage, provided that:

1. Concrete cover over beam sides and soffit is at least 2 inches (51 mm).
2. The top of the beam is at least 1<sup>1</sup>/<sub>2</sub> inches (38 mm) below the top and 2 inches (51 mm) above bottom of the slab.
3. Concrete encasement contains adequate mesh or other reinforcing steel throughout the whole depth and across the soffit of the beam to prevent spalling of the concrete. Shear connectors must be provided for composite action if the steel member is not totally encased in concrete. The portion of the effective width of the concrete slab on each side of the beam centerline shall not exceed:
  - a. One-eighth of the beam span, center-to-center of supports;
  - b. One-half the distance to the centerline of the adjacent beam; or
  - c. The distance from the beam centerline to the edge of the slab.

### 12. DESIGN ASSUMPTIONS

1. Encased beams shall be proportioned to support, unassisted, all dead loads applied prior to the hardening of the concrete (unless these loads are supported temporarily on shoring) and, acting in conjunction with the slab, to support all dead and live loads applied after hardening of the concrete, without exceeding a computed bending stress of  $0.66F_y$ , where  $F_y$  is the yield stress of the steel beam. The bending stress produced by loads after the concrete has hardened shall be computed on the basis of the section properties of the composite section. Concrete tension stresses shall be neglected. Alternatively, the steel beam alone may be proportioned to resist, unassisted, the positive moment produced by all loads, live and dead, using a bending stress equal to  $0.76F_y$ , in which case temporary shoring is not required.

2. When shear connectors are used in accordance with Section I4, the composite section shall be proportioned to support all of the loads without exceeding the allowable stress prescribed in Section F1.1, even when the steel section is not shored during construction. In positive moment areas, the steel section is exempt from compact flange criteria (Section B5) and there is no limit on the unsupported length of the compression flange.

Reinforcement parallel to the beam within the effective width of the slab, when anchored in accordance with the provisions of the applicable building code, may be included in computing the properties of composite sections, provided shear connectors are furnished in accordance with the requirements of Section I4. The section properties of the composite section shall be computed in accordance with the elastic theory. Concrete tension stresses shall be neglected. For stress computations, the compression area of lightweight or normal-weight concrete shall be treated as an equivalent area of steel by dividing it by the modular ratio  $n$  for normal-weight concrete of the strength specified when determining the section properties. For deflection calculations, the transformed section properties shall be based on the appropriate modular ratio  $n$  for the strength and weight concrete specified, where  $n = E/E_c$ .

In cases where it is not feasible or necessary to provide adequate connectors to satisfy the horizontal shear requirements for full composite action, the effective section modulus shall be determined as

$$S_{eff} = S_s + \sqrt{\frac{V'_h}{V_h}} (S_{tr} - S_s) \quad (I2-1)$$

**WHERE:**

$V_h$  and  $V'_h$  are defined in Section I4.

$S_s$  = section modulus of the steel beam referred to its bottom flange, in.<sup>3</sup> (mm<sup>3</sup>)

$S_{tr}$  = section modulus of the transformed composite section referred to its bottom flange, based upon maximum permitted effective width of concrete flange (Section I1), in.<sup>3</sup> (mm<sup>3</sup>)

For composite beams constructed without temporary shoring, stresses in the steel section shall not exceed  $0.90F_y$ . Stresses shall be computed assuming the steel section alone resists all loads applied before the concrete has reached 75 percent of its required strength and the effective composite section resists all loads applied after that time.

The actual section modulus of the transformed composite section shall be used in calculating the concrete flexural compression stress and, for construction without temporary shores, this stress shall be based upon loading applied after the concrete has reached 75 percent of its required strength. The stress in the concrete shall not exceed  $0.45 f'_c$ .

**I3. END SHEAR**

The web and the end connections of the steel beam shall be designed to carry the total reaction.

**I4. SHEAR CONNECTORS**

Except in the case of encased beams, as defined in Section I2.1, the entire horizontal shear at the junction of the steel beam and the concrete slab shall be assumed to be transferred by shear connectors welded to the top flange of the beam and embedded in the concrete. For full composite action with concrete subject to flexural compression, the total horizontal shear to be resisted between the point of maximum positive moment and points of zero moment shall be taken as the smaller value using Equations (I4-1) and (I4-2):

$$V'_h = 0.85 f'_c A_c / 2 \quad (I4-1)^*$$

and

$$V_h = f_y A_s / 2 \quad (I4-2)$$

**WHERE:**

$f'_c$  = specified compression strength of concrete, ksi (N/mm<sup>2</sup>).

$A_c$  = actual area of effective concrete flange defined in Section I1, in.<sup>2</sup> (mm<sup>2</sup>)

$A_s$  = area of steel beam, in.<sup>2</sup> (mm<sup>2</sup>)

In continuous composite beams where longitudinal reinforcing steel is considered to act compositely with the steel beam in the negative moment regions, the total horizontal shear to be resisted by shear connectors between an interior support and each adjacent point of contraflexure shall be taken as

$$V_h = F_{yr} A_{sr} / 2 \quad (I4-3)$$

**WHERE:**

$A_{sr}$  = total area of longitudinal reinforcing steel at the interior support located within the effective flange width specified in Section I1, in.<sup>2</sup> (mm<sup>2</sup>)

$F_{yr}$  = specified minimum yield stress of the longitudinal reinforcing steel, ksi (N/mm<sup>2</sup>).

For full composite action, the number of connectors resisting the horizontal shear,  $V_h$ , each side of the point of maximum moment, shall not be less than that determined by the relationship  $V_h/q$ ,

\*The term  $1/2 F_{yr} A'_s$ , shall be added to the right-hand side of Equation (I4-1) if longitudinal reinforcing steel with area  $A'_s$  located within the effective width of the concrete flange is included in the properties of the composite section.

where  $q$ , the allowable shear load for one connector, is given in Table I4.1 for flat soffit concrete slabs made with C33 aggregates. For flat soffit concrete slabs made with rotary kiln-produced aggregates, conforming to C330 with concrete unit weight not less than 90 pcf (1442 kg/m<sup>2</sup>), the allowable shear load for one connector is obtained by multiplying the values from Table I4.1 by the coefficient from Table I4.2.

For partial composite action with concrete subject to flexural compression, the horizontal shear  $V'_h$  to be used in computing  $S_{eff}$  shall be taken as the product of  $q$  times the number of connectors furnished between the point of maximum moment and the nearest point of zero moment.

The value of  $V'_h$  shall not be less than one fourth the smaller value of Equation (I4-1), using the maximum permitted effective width of the concrete flange, or Equation (I4-2). The effective moment of inertia for deflection computations shall be determined by:

$$I_{eff} = I_s + \sqrt{\frac{V'_h}{V_h}} (I_{tr} - I_s) \tag{I4-4}$$

**WHERE:**

- $I_s$  = moment of inertia of the steel beam, in.<sup>4</sup> (mm<sup>4</sup>)
- $I_{tr}$  = moment of inertia of the transformed composite section, in.<sup>4</sup> (mm<sup>4</sup>)

**TABLE I4.1**  
Allowable Horizontal  
Shear Load for One Connector ( $q$ ), kips<sup>a</sup>  
(× 4.45 for kN)

Connector <sup>b</sup>	Specified Compressive Strength of Concrete ( $f'_c$ ), ksi		
	× 6.89 for N/mm <sup>2</sup>		
× 25.4 for mm	3.0	3.5	≥ 4.0
1/2" dia. × 2" hooked or headed stud	5.1	5.5	5.9
5/8" dia. × 2 1/2" hooked or headed stud	8.0	8.6	9.2
3/4" dia. × 3" hooked or headed stud	11.5	12.5	13.3
7/8" dia. × 3 1/2" hooked or headed stud	15.6	16.8	18.0
Channel C3 × 4.1	4.3w <sup>c</sup>	4.7w <sup>c</sup>	5.0w <sup>c</sup>
Channel C4 × 5.4	4.6w <sup>c</sup>	5.0w <sup>c</sup>	5.3w <sup>c</sup>
Channel C5 × 6.7	4.9w <sup>c</sup>	5.3w <sup>c</sup>	5.6w <sup>c</sup>

<sup>a</sup>Applicable only to concrete made with ASTM C33 aggregates.  
<sup>b</sup>The allowable horizontal loads tabulated are also permitted for studs longer than shown.  
<sup>c</sup>w = length of channel, in. (mm)

**TABLE I4.2**  
Coefficients for Use with Concrete Made  
with C330 Aggregates

Specified Compressive Strength of Concrete ( $f'_c$ )	Air Dry Unit Weight of Concrete, pcf						
	× 16.02 for kg/m <sup>2</sup>						
× 6.89 for N/mm <sup>2</sup>	90	95	100	105	110	115	120
≤ 4.0 ksi	0.73	0.76	0.78	0.81	0.83	0.86	0.88
≥ 5.0 ksi	0.82	0.85	0.87	0.91	0.93	0.96	0.99

The connectors required on each side of the point of maximum moment in an area of positive bending may be uniformly distributed between that point and adjacent points of zero moment, except that  $N_2$ , the number of shear connectors required between any concentrated load in that area and the nearest point of zero moment, shall not be less than that determined by Equation (I4-5).

$$N_2 = \frac{N_1 \left[ \frac{M\beta}{M_{\max}} - 1 \right]}{\beta - 1} \quad (14-5)$$

**WHERE:**

- $M$  = moment (less than the maximum moment) at a concentrated load point
- $N_1$  = number of connectors required between point of maximum moment and point of zero moment, determined by the relationship  $V_h/q$  or  $V'_h/q$ , as applicable
- $\beta = \frac{S_{tr}}{S_s}$  or  $\frac{S_{eff}}{S_s}$ , as applicable

For a continuous beam, connectors required in the region of negative bending may be uniformly distributed between the point of maximum moment and each point of zero moment.

Shear connectors shall have at least 1 inch (25 mm) of lateral concrete cover, except for connectors installed in the ribs of formed steel decks. Unless located directly over the web, the diameter of studs shall not be greater than  $2^{1/2}$  times the thickness of the flange to which they are welded. The minimum center-to-center spacing of stud connectors shall be 6 diameters along the longitudinal axis of the supporting composite beam and 4 diameters transverse to the longitudinal axis of the supporting composite beam. The maximum center-to-center spacing of stud connectors shall not exceed 8 times the total slab thickness.

**15. COMPOSITE BEAMS OR GIRDERS WITH FORMED STEEL DECK**

Composite construction of concrete slabs on formed steel deck connected to steel beams or girders shall be designed by the applicable portions of Sections I1 through I4, with the following modifications.

**1. General.** 1. Section I5 is applicable to decks with nominal rib height not greater than 3 inches (76 mm).

2. The average width of concrete rib or haunch  $w_r$  shall not be less than 2 inches (51 mm), but shall not be taken in calculations as more than the minimum clear width near the top of the steel deck. See Section I5.3, Subparagraphs 2 and 3, for additional provisions.

3. The concrete slab shall be connected to the steel beam or girder with welded stud shear connectors  $3/4$  in. (19 mm) or less in diameter. Studs may be welded through the deck or directly to the steel member.

4. Stud shear connectors shall extend not less than  $1^{1/2}$  inches (38 mm) above the top of the steel deck after installation.

5. The slab thickness above the steel deck shall not be less than 2 inches (51 mm).

**2. Deck Ribs Oriented Perpendicular to Steel Beam or Girder.** 1. Concrete below the top of the steel deck shall be neglected when determining section properties and in calculating  $A_c$  for Equation (I4-1).

2. The spacing of stud shear connectors along the length of a supporting beam or girder shall not exceed 36 inches (914 mm).

3. The allowable horizontal shear load per stud connector  $q$  shall be the value stipulated in Section I4 (Tables I4.1 and I4.2) multiplied by the following reduction factor:

$$\left( \frac{0.85}{\sqrt{N_r}} \right) \left( \frac{w_r}{h_r} \right) \left( \frac{H_s}{h_r} - 1.0 \right) \leq 1.0 \quad (15-1)$$

**WHERE:**

- $h_r$  = nominal rib height, in. (mm)

$H_s$  = length of stud connector after welding, in. (mm), not to exceed the value  $(h_r + 3)$  in computations, although the actual length may be greater.

$N_r$  = number of stud connectors on a beam in one rib, not to exceed 3 in computations, although more than 3 studs may be installed.

$w_r$  = average width of concrete rib, in. (mm) (see Section I5.1, Subparagraph 2).

4. To resist uplift, the steel deck shall be anchored to all compositely designed steel beams or girders at a spacing not to exceed 16 inches (406 mm). Such anchorage may be provided by stud connectors, a combination of stud connectors and arc spot (puddle) welds, or other devices specified by the designer.

**3. Deck Ribs Oriented Parallel to Steel Beam or Girder.** 1. Concrete below the top of the steel deck may be included when determining section properties and shall be included in calculating  $A_c$  for Equation (I4-1).

2. Steel deck ribs over supporting beams or girders may be split longitudinally and separated to form a concrete haunch.

3. When the nominal depth of steel deck is  $1\frac{1}{2}$  inch (38 mm) or greater, the average width  $w_r$  of the supported haunch or rib shall not be less than 2 inches (51 mm) for the first stud in the transverse row plus four stud diameters for each additional stud.

4. The allowable horizontal shear load per stud connector  $q$  shall be the value stipulated in Section I4 (Tables I4.1 and I4.2), except when the ratio  $w_r/h_r$  is less than 1.5, the allowable load shall be multiplied by the following reduction factor:

$$0.6\left(\frac{w_r}{h_r}\right)\left(\frac{H_s}{h_r} - 1.0\right) \leq 1.0 \quad (15-2)$$

where  $h_r$  and  $H_s$  are as defined in Section I5.2 and  $w_r$  is the average width of concrete rib or haunch (see Section I5.1, Subparagraph 2, and Section I5.3, Subparagraph 3).

## 16. SPECIAL CASES

When composite construction does not conform to the requirements of Sections I1 through I5, the allowable load per shear connector must be established by a suitable test program.

## CHAPTER J

### CONNECTIONS, JOINTS AND FASTENERS

This chapter applies to connections consisting of connecting elements (plates, stiffeners, gussets, angles, brackets) and connectors (welds, bolts, rivets).

#### J1. GENERAL PROVISIONS

**1. Design Basis.** Connections shall be proportioned so that the calculated stress is less than the allowable stress determined (1) by structural analysis for loads acting on the structure or (2) as a specified proportion of the strength of the connected members, whichever is appropriate.

**2. Simple Connections.** Except as otherwise indicated in the design documents, connections of beams, girders or trusses shall be designed as flexible and ordinarily may be proportioned for the reaction shears only. Flexible beam connections shall accommodate end rotations of unrestrained (simple) beams. To accomplish this, in elastic deformation in the connection is permitted.

**3. Moment Connections.** End connections of restrained beams, girders and trusses shall be designed for the combined effect of forces resulting from moment and shear induced by the rigidity of the connections.

**4. Compression Members with Bearing Joints.** When columns bear on bearing plates or are finished to bear at splices, there shall be sufficient connectors to hold all parts securely in place.

When other compression members are finished to bear, the splice material and its connectors shall be arranged to hold all parts in line and shall be proportioned for 50 percent of the strength of the member.

All compression joints shall be proportioned to resist any tension developed by the specified lateral loads acting in conjunction with 75 percent of the calculated dead-load stress and no live load.

**5. Connections of Tension and Compression Members in Trusses.** The connections at ends of tension or compression members in trusses shall develop the force due to the design load, but not less than 50 percent of the effective strength of the member, unless a smaller percentage is justified by engineering analysis that considers other factors including handling, shipping and erection.

**6. Minimum Connections.** Connections carrying calculated stresses, except for lacing, sag bars and girts, shall be designed to support not less than 6 kips (26 688 N).

**7. Splices in Heavy Sections.** This section applies to A6 Group 4 and 5 rolled shapes, or shapes built-up by welding plates more than 2 inches (51 mm) thick together to form the cross section\*, and where the cross section is to be spliced and subject to primary tensile stresses due to tension or flexure.

When tensile forces in these sections are to be transmitted through splices by full-penetration groove welds, material notch-toughness requirements as given in Section A3.1c, weld access holes details as given in Section J1.8, compatible welding procedures as given in Section J2.6, welding preheat requirements as given in Section J2.7 and thermal cut surface preparation and inspection requirements as given in Section M2.2 apply.

At tension splices in these sections, weld tabs and backing shall be removed and the surfaces ground smooth.

When splicing these sections, and where the section is to be used as a primary compression member, all weld access holes required to facilitate groove welding operations shall satisfy the provisions of Section J1.8.

Alternatively, splicing of such members subject to compression, including members which are subject to tension due to wind or seismic loads, may be accomplished using splice details which do not induce large weld shrinkage strains such as partial-penetration flange groove welds with fillet-welded surface lap plate splices on the web, or with bolted or combination bolted/fillet-welded lap plate splices.

**8. Beam Copes and Weld Access Holes.** All weld access holes required to facilitate welding operations shall have a length from the toe of the weld preparation not less than one and one-half times the thickness of the material in which the hole is made. The height of the access hole shall be adequate for deposition of sound weld metal in the adjacent plates and provide clearance for weld tabs. In hot-rolled shapes and built-up shapes, all beam copes and weld access holes shall be shaped free of notches or sharp reentrant corners except that, when fillet web-to-flange welds are used in built-up shapes, access holes are permitted to terminate perpendicular to the flange.

For Group 4 and 5 shapes and built-up shapes of material more than 2 inches (51 mm) thick, the thermally cut surfaces of beam copes and weld access holes shall be ground to bright metal and inspected by either magnetic particle or dye penetrant methods. If the curved transition portion of weld access holes and beam copes are formed by predrilled or sawed holes, that portion of the access hole or cope need not be ground. Weld access holes and beam copes in other shapes need not be ground or inspected by dye penetrant or magnetic particle.

**9. Placement of Welds, Bolts and Rivets.** Groups of welds, bolts or rivets at the ends of any member which transmit axial stress into that member shall be sized so the center of gravity of the

---

\*When the individual elements of the cross section are spliced prior to being joined to form the cross section in accordance with the *Structural Welding Code—Steel*, AWS D1.1, Article 3.4.6, the applicable provisions of the *Structural Welding Code—Steel*, AWS D1.1 apply in lieu of the requirements of this section.

group coincides with the center of gravity of the member, unless provision is made for the eccentricity. The foregoing provision is not applicable to end connections of statically loaded single-angle, double-angle and similar members. Eccentricity between the gravity axes of such members and the gage lines for their riveted or bolted end connections may be neglected in statically loaded members, but shall be considered in members subject to fatigue loading.

See Section E4 for placement of fasteners in built-up members made of weathering steel.

**10. Bolts in Combination with Welds.** In new work, A307 bolts or high-strength bolts used in bearing-type connections shall not be considered as sharing the stress in combination with welds. Welds, if used, shall be provided to carry the entire stress in the connection. High-strength bolts proportioned for slip-critical connections may be considered as sharing the stress with the welds.

In making welded alterations to structures, existing rivets and high-strength bolts tightened to the requirements for slip-critical connections are permitted for carrying stresses resulting from loads present at the time of alteration, and the welding need be adequate to carry only the additional stress.

**11. High-strength Bolts in Slip-critical Connections in Combination with Rivets.** In both new work and alterations, high-strength bolts in slip-critical connections may be considered as sharing the load with rivets.

**12. Limitations on Bolted and Welded Connections.** Fully-tensioned high-strength bolts (see Table J3.7) or welds shall be used for the following connections:

Column splices in all tier structures 200 feet (60.96 m) or more in height

Column splices in tier structures 100 to 200 feet (30.48 m to 60.96 m) in height, if the least horizontal dimension is less than 40 percent of the height

Column splices in tier structures less than 100 feet (30.48 m) in height, if the least horizontal dimension is less than 25 percent of the height

Connections of all beams and girders to columns and of any other beams and girders on which the bracing of columns is dependent, in structures over 125 feet (38.10 m) in height

In all structures carrying cranes of over 5-ton (44 480 N) capacity: roof truss splices and connections of trusses to columns, column splices, column bracing, knee braces and crane supports

Connections for supports of running machinery or of other live loads which produce impact or reversal of stress

Any other connections stipulated on the design plans

In all other cases, connections may be made with high-strength bolts tightened to the snug-tight condition or with A307 bolts

For the purpose of this section, the height of a tier structure shall be taken as the vertical distance from the curb level to the highest point of the roof beams in the case of flat roofs, or to the mean height of the gable in the case of roofs having a rise of more than  $2\frac{2}{3}$  in 12 (22.3%). Where the curb level has not been established, or where the structure does not adjoin a street, the mean level of the adjoining land shall be used instead of curb level. Penthouses may be excluded in computing the height of the structure.

## J2. WELDS

All provisions of American Welding Society's *Structural Welding Code—Steel*, AWS D1.1, except Sections 2.3, 2.4, 2.5, 8.13.1, 9 and 10, apply to work performed under this Specification.

### 1. Groove Welds

**a. Effective area.** The effective area of groove welds shall be considered as the effective length of the weld times the effective throat thickness.

The effective length of a groove weld shall be the width of the part joined.

The effective throat thickness of a complete-penetration groove weld shall be the thickness of the thinner part joined.

The effective throat thickness of a partial-penetration groove weld shall be as shown in Table J2.1.

The effective throat thickness of a flare groove weld when flush to the surface of a bar or 90° bend in a formed section shall be as shown in Table J2.2. Random sections of production welds for each welding procedure, or such test sections as may be required by design documents, shall be used to verify that the effective throat is consistently obtained.

Larger effective throat thicknesses than those in Table J2.2 are permitted, provided the fabricator can establish by qualification that the fabricator can consistently provide such larger effective throat thicknesses. Qualification shall consist of sectioning the weld normal to its axis, at mid-length and terminal ends. Such sectioning shall be made on a number of combinations of material sizes representative of the range to be used in the fabrication or as required by the designer.

**b. Limitations.** The minimum effective throat thickness of a partial-penetration groove weld shall be as shown in Table J2.3. Minimum effective throat thickness is determined by the thicker of the two parts joined, except that the weld size need not exceed the thickness of the thinnest part joined. For this exception, particular care shall be taken to provide sufficient preheat for soundness of the weld.

**2. Fillet Welds**

**a. Effective area.** The effective area of fillet welds shall be taken as the effective length times the effective throat thickness.

**TABLE J2.1**  
Effective Throat Thickness of Partial-penetration Groove Welds

Welding Process	Welding Position	Included Angle at Root of Groove	Effective Throat Thickness
Shielded metal arc Submerged arc Gas metal arc Flux-cored arc	All	J or U joint	Depth of chamfer
		Bevel or V joint ≥ 60°	
		Bevel or V joint < 60° but ≥ 45°	Depth of chamfer minus 1/8-in. (3.2 mm)

**TABLE J2.2**  
Effective Throat Thickness of Flare Groove Welds

Type of Weld	Radius (R) of Bar or Bend	Effective Throat Thickness
		× 25.4 for mm
Flare bevel groove	All	5/16R
Flare V-groove	All	1/2R <sup>a</sup>

<sup>a</sup>Use 3/8R for Gas Metal Arc Welding (except short circuiting transfer process) when R ≥ 1/2-in. (13 mm).

**TABLE J2.3**  
**Minimum Effective Throat Thickness of**  
**Partial-penetration Groove Welds**

Material Thickness of Thicker Part Joined (in.)	Minimum Effective Throat Thickness <sup>a</sup> (in.)
× 25.4 for mm	
To 1/4 inclusive	1/8
Over 1/4 to 1/2	3/16
Over 1/2 to 3/4	1/4
Over 3/4 to 1 1/2	5/16
Over 1 1/2 to 2 1/4	3/8
Over 2 1/4 to 6	1/2
Over 6	5/8

<sup>a</sup>See Sect. J2.

The effective length of fillet welds, except fillet welds in holes and slots, shall be the overall length of full-size fillets, including returns.

The effective throat thickness of a fillet weld shall be the shortest distance from the root of the joint to the face of the diagrammatic weld, except that for fillet welds made by the submerged arc process, the effective throat thickness shall be taken equal to the leg size for 3/8-inch (9.5 mm) and smaller fillet welds, and equal to the theoretical throat plus 0.11 inch (2.8 mm) for fillet welds larger than 3/8 inch (9.5 mm).

For fillet welds in holes and slots, the effective length shall be the length of the centerline of the weld along the center of the plane through the throat. In the case of overlapping fillets, the effective area shall not exceed the nominal cross-sectional area of the hole or slot in the plane of the faying surface.

**b. Limitations.** The *minimum size of fillet welds* shall be as shown in Table J2.4. Minimum weld size is dependent upon the thicker of the two parts joined, except that the weld size need not exceed the thickness of the thinner part. For this exception, particular care shall be taken to provide sufficient preheat for soundness of the weld. Weld sizes larger than the thinner part joined are permitted if required by calculated strength. In the as-welded condition, the distance between the edge of the base metal and the toe of the weld may be less than 1/16 inch (1.6 mm) provided the weld size is clearly verifiable.

The *maximum size of fillet welds* that is permitted along edges of connected parts shall be:

- Material less than 1/4 inch (6.4 mm) thick, not greater than the thickness of the material.
- Material 1/4 inch (6.4 mm) or more in thickness, not greater than the thickness of the material minus 1/16 inch (1.6 mm), unless the weld is especially designated on the drawings to be built out to obtain full-throat thickness.

**TABLE J2.4**  
**Minimum Size of Fillet Welds**

Material Thickness of Thicker Part Joined (in.)	Minimum Size of Fillet Weld <sup>a</sup> (in.)
× 25.4 for mm	
To 1/4 inclusive	1/8
Over 1/4 to 1/2	3/16
Over 1/2 to 3/4	1/4
Over 3/4	5/16

<sup>a</sup>Leg dimension of fillet welds. Single-pass welds must be used.

The *minimum effective length of fillet welds* designed on the basis of strength shall be not less than 4 times the nominal size, or else the size of the weld shall be considered not to exceed one fourth of its effective length. If longitudinal fillet welds are used alone in end connections of flat bar tension members, the length of each fillet weld shall not be less than the perpendicular distance between them. The transverse spacing of longitudinal fillet welds used in end connections of tension members shall not exceed 8 inches (203 mm), unless the member is designed on the basis of effective net area in accordance with Section B3.

*Intermittent fillet welds* are permitted to transfer calculated stress across a joint or faying surfaces when the strength required is less than that developed by a continuous fillet weld of the smallest permitted size, and to join components of built-up members. The effective length of any segment of intermittent fillet welding shall not be less than four times the weld size, with a minimum of 1½ inches (38 mm).

In *lap joints*, the minimum lap shall be five times the thickness of the thinner part joined, but not less than 1 inch (25 mm). Lap joints joining plates or bars subjected to axial stress shall be fillet welded along the end of both lapped parts, except where the deflection of the lapped parts is sufficiently restrained to prevent opening of the joint under maximum loading.

*Fillet welds in holes or slots* are permitted to transmit shear in lap joints or to prevent the buckling or separation of lapped parts and to join components of built-up members. Such fillet welds may overlap, subject to the provisions of Section J2. Fillet welds in holes or slots are not to be considered plug or slot welds.

*Side or end fillet welds* terminating at ends or sides, respectively, of parts or members shall, wherever practicable, be returned continuously around the corners for a distance not less than 2 times the nominal size of the weld. This provision shall apply to side and top fillet welds connecting brackets, beam seats and similar connections, on the plane about which bending moments are computed. For framing angles and simple end plate connections which depend upon flexibility of the outstanding legs for connection flexibility, end returns shall not exceed four times the nominal size of the weld. Fillet welds which occur on opposite sides of a common plane shall be interrupted at the corner common to both welds. End returns shall be indicated on the design and detail drawings.

### 3. Plug and Slot Welds.

**a. Effective area.** The effective shearing area of plug and slot welds shall be considered as the nominal cross-sectional area of the hole or slot in the plane of the faying surface.

**b. Limitations.** Plug or slot welds are permitted to transmit shear in lap joints or to prevent buckling of lapped parts and to join component parts of built-up members.

The diameter of the hole for a plug weld shall not be less than the thickness of the part containing it plus 5/16 inch (7.9 mm), rounded to the next larger odd 1/16 inch (1.6 mm), nor greater than the minimum diameter plus 1/8 inch (3.2 mm) or 2¼ times the thickness of the weld.

The minimum center-to-center spacing of plug welds shall be four times the diameter of the hole.

The minimum spacing of lines of slot welds in a direction transverse to their length shall be four times the width of the slot. The minimum center-to-center spacing in a longitudinal direction on any line shall be two times the length of the slot.

The length of slot for a slot weld shall not exceed 10 times the thickness of the weld. The width of the slot shall not be less than the thickness of the part containing it plus 5/16 inch (7.9 mm), rounded to the next larger odd 1/16 inch (1.6 mm), nor shall it be larger than 2¼ times the thickness of the weld. The ends of the slot shall be semicircular or shall have the corners rounded to a radius not less than the thickness of the part containing it, except those ends which extend to the edge of the part.

The thickness of plug or slot welds in material 5/8 inch (16 mm) or less in thickness shall be equal to the thickness of the material. In material over 5/8 inch (16 mm) thick, the thickness of the weld shall be at least one half the thickness of the material but not less than 5/8 inch (16 mm).

**4. Allowable Stresses.** Except as modified by the provisions of Section K4, welds shall be proportioned to meet the stress requirements given in Table J2.5.

**5. Combination of Welds.** If two or more of the general types of weld (groove, fillet, plug, slot) are combined in a single joint, the effective capacity of each shall be separately computed with reference to the axis of the group in order to determine the allowable capacity of the combination.

**TABLE J2.5**  
**Allowable Stress on Welds<sup>f</sup>**

Type of Weld and Stress <sup>a</sup>	Allowable Stress	Required Weld Strength Level <sup>b,c</sup>
	$\times 6.89$ for N/mm <sup>2</sup>	
Complete-penetration Groove Welds		
Tension normal to effective area	Same as base metal	"Matching" weld metal shall be used.
Compression normal to effective area	Same as base metal	Weld metal with a strength level equal to or less than "matching" weld metal is permitted.
Tension or compression parallel to axis of weld	Same as base metal	
Shear on effective area	$0.30 \times$ nominal tensile strength of weld metal (ksi)	
Partial-penetration Groove Welds <sup>d</sup>		
Compression normal to effective area	Same as base metal	Weld metal with a strength level equal to or less than "matching" weld metal is permitted.
Tension or compression parallel to axis of weld <sup>e</sup>	Same as base metal	
Shear parallel to axis of weld	$0.30 \times$ nominal tensile strength of weld metal (ksi)	
Tension normal to effective area	$0.30 \times$ nominal tensile strength of weld metal (ksi), except tensile stress on base metal shall not exceed $0.60 \times$ yield stress of base metal	
Fillet Welds		
Shear on effective area	$0.30 \times$ nominal tensile strength of weld metal (ksi)	Weld metal with a strength level equal to or less than "matching" weld metal is permitted.
Tension or compression parallel to axis of weld <sup>e</sup>	Same as base metal	
Plug and Slot Welds		
Shear parallel to faying surfaces (on effective area)	$0.30 \times$ nominal tensile strength of weld metal (ksi)	Weld metal with a strength level equal to or less than "matching" weld metal is permitted.
<sup>a</sup> For definition of effective area, see Section J2. <sup>b</sup> For "matching" weld metal, see Table 4.1.1, AWS D1.1. <sup>c</sup> Weld metal one strength level stronger than "matching" weld metal will be permitted. <sup>d</sup> See Section J2.1b for a limitation on use of partial-penetration groove welded joints. <sup>e</sup> Fillet welds and partial-penetration groove welds joining the component elements of built-up members, such as flange-to-web connections, may be designed without regard to the tensile or compressive stress in these elements parallel to the axis of the welds. <sup>f</sup> The design of connected material is governed by Chapters D through G. Also see Commentary Section J2.4.		

**6. Mixed Weld Metal.** When notch-toughness is specified, the process consumables for all weld metal, tack welds, root pass and subsequent passes, deposited in a joint shall be compatible to assure notch-tough composite weld metal.

**7. Preheat for Heavy Shapes.** For ASTM A 6 Group 4 and 5 shapes and welded built-up members made of plates more than 2 inches (51 mm) thick, a preheat equal to or greater than 350°F. (177°C.) shall be used when making groove weld splices.

**J3. BOLTS, THREADED PARTS AND RIVETS**

**1. High-strength Bolts.** Except as otherwise provided in this Specification, use of high-strength bolts shall conform to the provisions of the *Specification for Structural Joints Using ASTM A325 or A490 Bolts* approved by the Research Council on Structural Connections of the Engineering Foundation (RCSC).

If required to be tightened to more than 50 percent of their minimum specified tensile strength, A449 bolts in tension and bearing-type shear connections shall have an F436 hardened washer installed under the bolt head, and the nuts shall meet the requirements of A563.

**2. Size and Use of Holes.** a. The *maximum sizes* of holes for bolts are given in Table J3.1, except that larger holes, required for tolerance on location of anchor bolts in concrete foundations, are permitted in column base details.

b. *Standard holes* shall be provided in member-to-member connections, unless oversized, short-slotted or long-slotted holes in bolted connections are approved by the designer. Finger shims up to 1/4 inch (6.4 mm) may be introduced into slip-critical connections designed on the basis of standard holes without reducing the allowable shear stress of the fastener.

**TABLE J3.1  
Nominal Hole Dimensions**

Bolt Diameter	Hole Dimensions			
	× 25.4 for mm			
Bolt Diameter (× 25.4 for mm)	Standard (Diameter)	Oversized (Diameter)	Short-slot (Width × length)	Long-slot (Width × length)
1/2	9/16	5/8	9/16 × 11/16	9/16 × 1 1/4
5/8	11/16	13/16	11/16 × 7/8	11/16 × 1 9/16
3/4	13/16	15/16	13/16 × 1	13/16 × 1 7/8
7/8	15/16	1 1/16	15/16 × 1 1/8	15/16 × 2 3/16
1	1 1/16	1 1/4	1 1/16 × 1 5/16	1 1/16 × 2 1/2
≥ 1 1/8	d + 1/16	d + 5/16	(d + 1/16) × (d + 3/8)	(d + 1/16) × (2.5 × d)

c. *Oversized holes* are permitted in any or all plies of slip-critical connections, but they shall not be used in bearing-type connections. Hardened washers shall be installed over oversized holes in an outer ply.

d. *Short-slotted holes* are permitted in any or all plies of slip-critical or bearing-type connections. The slots are permitted without regard to direction of loading in slip-critical connections, but the length shall be normal to the direction of the load in bearing-type connections. Washers shall be installed over short-slotted holes in an outer ply; when high-strength bolts are used, such washers shall be hardened.

e. *Long-slotted holes* are permitted in only one of the connected parts of either a slip-critical or bearing-type connection at an individual faying surface. Long-slotted holes are permitted without regard to direction of loading in slip-critical connections, but shall be normal to the direction of load in bearing-type connections. Where long-slotted holes are used in an outer ply, plate washers or a continuous bar with standard holes, having a size sufficient to completely cover the slot after installation, shall be provided. In high-strength bolted connections, such plate washers or continuous bars shall not be less than 5/16 inch (7.9 mm) thick and shall be of structural grade material, but need not be hardened. If hardened washers are required for use of high-strength bolts, the hardened washers shall be placed over the outer surface of the plate washer or bar.

f. When A490 bolts over 1-inch (25 mm) diameter are used in slotted or oversized holes in external plies, a single hardened washer conforming to ASTM F 436, except with  $\frac{5}{16}$  inch (7.9 mm) minimum thickness, shall be used in lieu of the standard washer.

**3. Effective Bearing Area.** The effective bearing area of bolts, threaded parts and rivets shall be the diameter multiplied by the length in bearing, except that for countersunk bolts and rivets one half the depth of the countersink shall be deducted.

**4. Allowable Tension and Shear.** Allowable tension and shear stresses on bolts, threaded parts and rivets shall be as given in Table J3.2, in ksi ( $\text{N}/\text{mm}^2$ ) of the nominal body area of rivets (before driving) or the unthreaded nominal body area of bolts and threaded parts other than upset rods (see Footnote c, Table J3.2). High-strength bolts supporting applied load by direct tension shall be so proportioned that their average tensile stress, computed on the basis of nominal bolt area and independent of any initial tightening force, will not exceed the appropriate stress given in Table J3.2. The applied load shall be the sum of the external load and any tension resulting from prying action produced by deformation of the connected parts.

When specified by the designer, the nominal slip resistance for connections having special faying surface conditions may be increased to the applicable values in the *RCSC Specification for Structural Joints Using ASTM A325 or A490 Bolts*.

Finger shims up to  $\frac{1}{4}$  inch (6.4 mm) may be introduced into slip-critical connections designed on the basis of standard holes without reducing the allowable shear stress of the fastener to that specified for slotted holes.

Design for bolts, threaded parts and rivets subject to fatigue loading shall be in accordance with Appendix K4.3.

TABLE J3.2  
Allowable Stress on Fasteners, ksi

Description of Fasteners	Allowable Tension <sup>g</sup> ( $F_t$ )  $\times 6.89$ for $N/mm^2$	Allowable Shear <sup>g</sup> ( $F_v$ ) $\times 6.89$ for $N/mm^2$				Bearing-type Connections <sup>j</sup>
		Slip-critical Connections <sup>g,i</sup>				
		Standard-size Holes	Over-sized and Short-slotted Holes	Long-slotted holes:		
				Transverse <sup>j</sup> Load	Parallel <sup>j</sup> Load	
A502, Gr. 1, hot-driven rivets	23.0 <sup>a</sup>					17.5 <sup>f</sup>
A502, Gr. 2 and 3, hot-driven rivets	29.0 <sup>a</sup>					22.0 <sup>f</sup>
A307 bolts	20.0 <sup>a</sup>					10.0 <sup>b,i</sup>
Threaded parts meeting the requirements of Sections A3.1 and A3.4 and A449 bolts meeting the requirements of Section A3.4, when threads are not excluded from shear planes	$0.33F_u^{a,c,h}$					$0.17F_u^h$
Threaded parts meeting the requirements of Sections A3.1 and A3.4, and A449 bolts meeting the requirements of Section A3.4, when threads are excluded from shear planes	$0.33F_u^{a,c,h}$					$0.22F_u^h$
A325 bolts, when threads are not excluded from shear planes	44.0 <sup>d</sup>	17.0	15.0	12.0	13.0	21.0 <sup>f</sup>
A325 bolts, when threads are excluded from shear planes	44.0 <sup>d</sup>	17.0	15.0	12.0	13.0	30.0 <sup>f</sup>
A490 bolts, when threads are not excluded from shear planes	54.0 <sup>d</sup>	21.0	18.0	15.0	13.0	28.0 <sup>f</sup>
A490 bolts, when threads are excluded from shear planes	54.0 <sup>d</sup>	21.0	18.0	15.0	13.0	40.0 <sup>f</sup>

<sup>a</sup>Static loading only.  
<sup>b</sup>Threads permitted in shear planes.  
<sup>c</sup>The tensile capacity of the threaded portion of an upset rod, based upon the cross-sectional area at its major thread diameter  $A_b$  shall be larger than the nominal body area of the rod before upsetting times  $0.60F_y$ .  
<sup>d</sup>For A325 and A490 bolts subject to tensile fatigue loading, see Appendix K4.3.  
<sup>e</sup>Class A (slip coefficient 0.33). Clean mill scale and blast-cleaned surfaces with Class A coatings. When specified by the designer, the allowable stress,  $F_v$ , for slip-critical connections having special faying surface conditions may be increased to the applicable value given in the RCSC Specification.  
<sup>f</sup>When bearing-type connections used to splice tension members have a fastener pattern whose length, measured parallel to the line of force, exceeds 50 in., tabulated values shall be reduced by 20%.  
<sup>g</sup>See Section A5.2.  
<sup>h</sup>See Table 2, Numerical Values Section for values for specific ASTM steel specifications.  
<sup>i</sup>For limitations on use of oversized and slotted holes, see Section J3.2.  
<sup>j</sup>Direction of load application relative to long axis of slot.

**5. Combined Tension and Shear in Bearing-type Connections.** Bolts and rivets subject to combined shear and tension shall be so proportioned that the tension stress  $F_t$  in ksi ( $N/mm^2$ ) on the nominal body area  $A_b$  produced by forces applied to the connected parts, shall not exceed the values computed from the equations in Table J3.3, where  $f_v$ , the shear stress produced by the same forces, shall not exceed the value for shear given in Table J3.2. When allowable stresses are increased for wind or seismic loads in accordance with Section A5.2, the constants in the equations listed in Table J3.3 shall be increased by one third, but the coefficient applied to  $f_v$  shall not be increased.

**6. Combined Tension and Shear in Slip-critical Joints.** For A325 and A490 bolts used in slip-critical connections, the maximum shear stress allowed by Table J3.2 shall be multiplied by the reduction factor  $(1 - f_t A_b / T_b)$ , where  $f_t$  is the average tensile stress due to a direct load applied to all of the bolts in a connection and  $T_b$  is the pretension load of the bolt specified in Table J3.7. When allowable stresses are increased for wind or seismic loads in accordance with the provisions of Section A5.2, the reduced allowable shear stress shall be increased by one third.

**7. Allowable Bearing at Bolt Holes.** On the projected area of bolts and rivets in shear connections with the end distance in the line of force not less than  $1\frac{1}{2}d$  and the distance center-to-center of bolts not less than  $3d$ :

1. In standard- or short-slotted holes with two or more bolts in the line of force,

$$F_p = 1.2 F_u \tag{J3-1}$$

**TABLE J3.3**  
Allowable Tension Stress  $F_t$  for Fasteners  
in Bearing-type Connections

Description of Fasteners	Threads Included in Shear Plane	Threads Excluded from Shear Plane
A307 bolts	$26 - 1.8f_v \leq 20$	
A325 bolts	$\sqrt{(44)^2 - 4.39f_v^2}$	$\sqrt{(44)^2 - 2.15f_v^2}$
A490 bolts	$\sqrt{(54)^2 - 3.75f_v^2}$	$\sqrt{(54)^2 - 1.82f_v^2}$
Threaded parts, A449 bolts over $1\frac{1}{2}$ -in. dia.	$0.43F_u - 1.8f_v \leq 0.33F_u$	$0.43F_t - 1.4f_v \leq 0.33F_u$
A502 Gr. 1 rivets	$30 - 1.3f_v \leq 23$	
A502 Gr 2 rivets	$38 - 1.3f_v \leq 29$	

For SI:

**TABLE J3.3**  
Allowable Tension Stress  $F_t$  for Fasteners  
in Bearing-type Connections

Description of Fasteners	Threads Included in Shear Plane	Threads Excluded from Shear Plane
A307 bolts	$179 - 1.8f_v \leq 138$	
A325 bolts	$\sqrt{(303)^2 - 4.39f_v^2}$	$\sqrt{(303)^2 - 2.15f_v^2}$
A490 bolts	$\sqrt{(372)^2 - 3.75f_v^2}$	$\sqrt{(372)^2 - 1.82f_v^2}$
Threaded parts, A449 bolts over $1\frac{1}{2}$ -in. dia.	$0.43F_u - 1.8f_v \leq 0.33F_u$	$0.43F_t - 1.4f_v \leq 0.33F_u$
A502 Gr. 1 rivets	$207 - 1.3f_v \leq 158$	
A502 Gr 2 rivets	$262 - 1.3f_v \leq 200$	

**WHERE:**

$$F_p = \text{allowable bearing stress, ksi (N/mm}^2\text{)}$$

2. In long-slotted holes with the axis of the slot perpendicular to the direction of load and with two or more bolts in the line of force,

$$F_p = 1.0 F_u \tag{J3-2}$$

On the projected area of the bolt or rivet closest to the edge in standard- or short-slotted holes with the edge distance less than  $1\frac{1}{2}d$  and in all connections with a single bolt in the line of force:

$$F_p = L_e F_u / 2d \leq 1.2 F_u \tag{J3-3}$$

**WHERE:**

$$L_e = \text{distance from the free edge to center of the bolt, in. (mm)}$$

$d$  = bolt dia., in. (mm)

If deformation around the hole is not a design consideration and adequate spacing and edge distance is as required by Sections J3.8 and J3.9, the following equation is permitted in lieu of Equation (J3-1):

$$F_p = 1.5F_u \tag{J3-4}$$

and the limit in Equation (J3-3) shall be increased to  $1.5F_u$ .

**8. Minimum Spacing.** The distance between centers of standard, oversized or slotted fastener holes shall not be less than two and two-thirds times the nominal diameter of the fastener or less than that required by the following paragraph, if applicable.

Along a line of transmitted forces, the distance between centers of holes  $s$  shall not be less than  $3d$  when  $F_p$  is determined by Equations (J3-1) and (J3-2). Otherwise, the distance between centers of holes shall not be less than the following:

**a. For standard holes:**

$$s \leq 2P/F_u t + d/2 \tag{J3-5}$$

**WHERE:**

$P$  = force transmitted by one fastener to the critical connected part, kips (N)

$F_u$  = specified minimum tensile strength of the critical connected part, ksi (N/mm<sup>2</sup>)

$t$  = thickness of the critical connected part, in. (mm)

**b. For oversized and slotted holes,** the distance required for standard holes in Subparagraph a (above), plus the applicable increment  $C_1$  from Table J3.4, but the clear distance between holes shall not be less than one bolt diameter.

**9. Minimum Edge Distance.** The distance from the center of a standard hole to an edge of a connected part shall not be less than the applicable value from Table J3.5 or the value from Equation (J3-6), as applicable.

Along a line of transmitted force, in the direction of the force, the distance from the center of a standard hole to the edge of the connected part  $L_e$  shall not be less than  $1\frac{1}{2}d$  when  $F_p$  is determined by Equations (J3-1) or (J3-2). Otherwise the edge distance shall not be less than

$$L_e \leq 2P/F_u t \tag{J3-6}$$

where  $P$ ,  $F_u$ ,  $t$  are as defined in Section J3.8.

**TABLE J3.4**  
Values of Spacing Increment  $C_1$ , in.

Nominal Dia. of Fastener	Oversize Holes	Slotted Holes		
		Perpendicular to Line of Force	Parallel to Line of Force	
			Short-slots	Long-slots <sup>a</sup>
× 25.4 for mm				
≤ 7/8	1/8	0	3/16	1 1/2 d - 1/16
1	3/16	0	1/4	1 7/16
≥ 1 1/8	1/4	0	5/16	1 1/2 d - 1/16

<sup>a</sup>When length of slot is less than maximum allowed in Table J3.1,  $C_1$  may be reduced by the difference between the maximum and actual slot lengths.

**TABLE J3.5**  
**Minimum Edge Distance, in.**  
(Center of Standard Hole<sup>a</sup> to Edge of Connected Part)

Nominal Bolt or Rivet Dia. (in.)	At Sheared Edges	At Rolled Edges of Plates, Shapes or Bars, Gas Cut or Saw-cut Edges <sup>b</sup>
× 25.4 for mm		
1/2	7/8	3/4
5/8	1 1/8	7/8
3/4	1 1/4	1
7/8	1 1/2 <sup>c</sup>	1 1/8
1	1 3/4 <sup>c</sup>	1 1/4
1 1/8	2	1 1/2
1 1/4	2 1/4	1 5/8
Over 1 1/4	1 3/4 x Dia.	1 1/4 x Dia.

<sup>a</sup>For oversized or slotted holes, see Table J3.6.  
<sup>b</sup>All edge distances in this column may be reduced 1/8-in. (3.2 mm) when the hole is at a point where stress does not exceed 25% of the maximum design strength in the element.  
<sup>c</sup>These may be 1 1/4 in. (32 mm) at the ends of beam connection angles.

The distance from the center of an oversized or slotted hole to an edge of a connected part shall not be less than required for a standard hole plus the applicable increment  $C_2$  from Table J3.6.

**10. Maximum Edge Distance and Spacing.** The maximum distance from the center of any rivet or bolt to the nearest edge of parts in contact shall be 12 times the thickness of the connected part under consideration, but shall not exceed 6 inches (152 mm). Bolted joints in unpainted steel exposed to atmospheric corrosion require special limitations on pitch and edge distance.

**TABLE J3.6**  
**Values of Edge Distance Increment  $C_2$ , in.**

Nominal Dia. of Fastener (in.)	Oversized Holes	Slotted Holes		Parallel to Edge
		Perpendicular to Edge		
		Short Slots	Long Slots <sup>a</sup>	
× 25.4 for mm				
≤ 7/8	1/16	1/8	3/4d	0
1	1/8	1/8		
≤ 1 1/8	1/8	3/16		

<sup>a</sup>When length of slot is less than maximum allowable (see Table J3.1),  $C_2$  may be reduced by one-half the difference between the maximum and actual slot lengths.

For unpainted, built-up members made of weathering steel which will be exposed to atmospheric corrosion, the spacing of fasteners connecting a plate and a shape or two-plate components in contact shall not exceed 14 times the thickness of the thinnest part or 7 inches (178 mm), and the maximum edge distance shall not exceed eight times the thickness of the thinnest part, or 5 inches (127 mm).

**11. Long Grips.** A307 bolts which carry calculated stress, with a grip exceeding five diameters, shall have their number increased 1 percent for each additional 1/16 inch (1.6 mm) in the grip.

**TABLE J3.7**  
**Minimum Pretension for Fully-tightened Bolts, kips<sup>a</sup>**

Bolt Size, in.	A325 Bolts	A490 Bolts
× 25.4 for mm	× 4448 for N	
1/2	12	15
5/8	19	24
3/4	28	35
7/8	39	49
1	51	64
1 1/8	56	80
1 1/4	71	102
1 3/8	85	121
1 1/2	103	143

<sup>a</sup>Equal to 0.70 of minimum tensile strength of bolts, rounded off to nearest kip, as specified in ASTM specifications for A325 and A490 bolts with UNC threads.

**J4. ALLOWABLE SHEAR RUPTURE**

At beam end connections where the top flange is coped, and in similar situations where failure might occur by shear along a plane through the fasteners, or by a combination of shear along a plane through the fasteners plus tension along a perpendicular plane:

$$F_v = 0.30F_u \tag{J4-1}$$

acting on the net shear area  $A_v$  and,

$$F_t = 0.50F_u \tag{J4-2}$$

acting on the net tension area  $A_t$ .

The minimum net failure path on the periphery of welded connections shall be checked.\*

**J5. CONNECTING ELEMENTS**

This section applies to the design of connecting elements, such as stiffeners, gussets, angles and brackets and the panel zones of beam-to-column connections.

**1. Eccentric Connections.** Intersecting axially stressed members shall have their gravity axes intersect at one point, if practicable; if not, provision shall be made for bending and shearing stresses due to the eccentricity.

**2. Allowable Shear Rupture.** For situations where failure might occur by shear along a plane through the fasteners, or by a combination of shear along a plane through the fasteners plus tension along a perpendicular plane, see Section J4.

**J6. FILLERS**

In welded construction, any filler 1/4 inch (6.4 mm) or more in thickness shall extend beyond the edges of the splice plate and shall be welded to the part on which it is fitted with sufficient weld to transmit the splice plate stress, applied at the surface of the filler as an eccentric load. The welds joining the splice plate to the filler shall be sufficient to transmit the splice plate stress and shall be long enough to avoid overstressing the filler along the toe of the weld. Any filler less than 1/4-inch (6.4 mm) thick shall have its edges flush with the edges of the splice plate and the weld size shall be the sum of the size necessary to carry the splice plate stress plus the thickness of the filler plate.

When bolts or rivets carrying computed stress pass through fillers thicker than 1/4 inch (6.4 mm), except in slip-critical connections assembled with high-strength bolts, the fillers shall be extended beyond the splice material and the filler extension shall be secured by enough bolts or rivets to distribute the total stress in the member uniformly over the combined section of the member and the

\*See Section B2.

filler, or an equivalent number of fasteners shall be included in the connection. Fillers between  $1/4$ -inch (6.4 mm) and  $3/4$ -inch (19 mm) thick, inclusive, need not be extended and developed, provided the allowable shear stress in the bolts is reduced by the factor,  $0.4(t - 0.25)$  [For SI:  $0.4(t - 6.4)$ ], where  $t$  is the total thickness of the fillers, up to  $3/4$  inch (19 mm).

### J7. SPLICES

Groove welded splices in plate girders and beams shall develop the full strength of the smaller spliced section. Other types of splices in cross sections of plate girders and beams shall develop the strength required by the stresses at the point of splice.

### J8. ALLOWABLE BEARING STRESS

On contact area of milled surfaces and ends of fitted bearing stiffeners; on projected area of pins in reamed, drilled or bored holes:

$$F_p = 0.90F_y^* \quad (J8-1)$$

Expansion rollers and rockers, kips per linear inch (N/mm):

$$F_p = \left( \frac{F_y - 13}{20} \right) 0.66d \quad (J8-2)$$

For SI: 
$$F_p = \left( \frac{F_y - 89.6}{20} \right) 0.66d$$

where  $d$  is the diameter of roller or rocker, inch (mm).

### J9. COLUMN BASES AND BEARING ON MASONRY AND CONCRETE

Proper provision shall be made to transfer the column loads and moments to the footings and foundations.

In the absence of code regulations, the following stresses apply:

On sandstone and limestone . . . . .  $F_p = 0.40$  ksi (2.8 N/mm<sup>2</sup>)

On brick in cement mortar . . . . .  $F_p = 0.25$  ksi (1.7 N/mm<sup>2</sup>)

On the full area of a concrete support . . . . .  $F_p = 0.35f'_c$

On less than the full area of a concrete support . . . . .  $F_p = 0.35f'_c$

#### WHERE:

$f'_c$  = specified compressive strength of concrete, ksi (N/mm<sup>2</sup>)

$A_1$  = area of steel concentrically bearing on a concrete support, in.<sup>2</sup> (mm<sup>2</sup>)

$A_2$  = maximum area of the portion of the supporting surface that is geometrically similar to and concentric with the loaded area, in.<sup>2</sup> (mm<sup>2</sup>)

### J10. ANCHOR BOLTS

Anchor bolts shall be designed to provide resistance to all conditions on completed structures of tension and shear at the bases of columns, including the net tensile components of any bending moment which may result from fixation or partial fixation of columns.

## CHAPTER K

### SPECIAL DESIGN CONSIDERATIONS

This chapter covers member strength design considerations related to concentrated forces, ponding, torsion and fatigue.

\*When parts in contact have different yield stresses,  $F_y$  shall be the smaller value.

## K1. WEBS AND FLANGES UNDER CONCENTRATED FORCES

**1. Design Basis.** Members with concentrated loads applied normal to *one flange* and symmetric to the web shall have a flange and web proportioned to satisfy the local flange bending, web yielding strength, web crippling and sidesway web buckling criteria of Sections K1.2, K1.3, K1.4 and K1.5. Members with concentrated loads applied to *both flanges* shall have a web proportioned to satisfy the web yielding, web crippling and column web buckling criteria of Sections K1.3, K1.4 and K1.6.

Where pairs of stiffeners are provided on opposite sides of the web, at concentrated loads, and extend at least half the depth of the member, Sections K1.2 and K1.3 need not be checked.

For column webs subject to high shears, see Section K1.7; for bearing stiffeners, see Section K1.8.

**2. Local Flange Bending.** A pair of stiffeners shall be provided opposite the tension flange or flange plate of the beam or girder framing into the member when the thickness of the member flange  $t_f$  is less than

$$0.4 \sqrt{\frac{P_{bf}}{F_{yc}}} \quad (\text{K1-1})$$

### WHERE:

$F_{yc}$  = column yield stress, ksi (N/mm<sup>2</sup>)

$P_{bf}$  = the computed force delivered by the flange or moment connection plate multiplied by <sup>5</sup>/<sub>3</sub>, when the computed force is due to live and dead load only, or by <sup>4</sup>/<sub>3</sub>, when the computed force is due to live and dead load in conjunction with wind or earthquake forces, kips (N).

If the length of loading measured across the member flange is less than  $0.15b$ , where  $b$  is the member flange width, Equation (K1-1) need not be checked.

**3. Local Web Yielding.** Bearing stiffeners shall be provided in beams and welded plate girders if the compressive stress at the web toe of the fillets resulting from concentrated loads exceeds  $0.66F_y$ .

a. When the force to be resisted is a concentrated load producing tension or compression, applied at a distance from the member end that is greater than the depth of the member,

$$\frac{R}{t_w(N + 5k)} \leq 0.66F_y \quad (\text{K1-2})$$

b. When the force to be resisted is a concentrated load applied at or near the end of the member,

$$\frac{R}{t_w(N + 2.5k)} \leq 0.66F_y \quad (\text{K1-3})$$

### WHERE:

$R$  = concentrated load or reaction, kips (N)

$t_w$  = thickness of web, in. (mm)

$N$  = length of bearing (not less than  $k$  for end reactions), in. (mm)

$k$  = distance from outer face of flange to web toe of fillet, in. (mm)

**4. Web Crippling.** Bearing stiffeners shall be provided in the webs of members under concentrated loads, when the compressive force exceeds the following limits:

a. When the concentrated load is applied at a distance not less than  $d/2$  from the end of the member:

$$R = 67.5t_w^2 \left[ 1 + 3 \left( \frac{N}{d} \right) \left( \frac{t_w}{t_f} \right)^{1.5} \right] \sqrt{F_{yw} t_f / t_w} \quad (\text{K1-4})$$

$$\text{For SI:} \quad R = 0.40t_w^2 \left[ 1 + 3 \left( \frac{N}{d} \right) \left( \frac{t_w}{t_f} \right)^{1.5} \right] \sqrt{EF_{yw} t_f / t_w}$$

b. When the concentrated load is applied less than a distance  $d/2$  from the end of the member:

$$R = 67.5t_w^2 \left[ 1 + 3 \left( \frac{N}{d} \right) \left( \frac{t_w}{t_f} \right)^{1.5} \right] \sqrt{F_{yw} t_f / t_w} \quad (\text{K1-5})$$

$$\text{For SI:} \quad R = 0.2t_w^2 \left[ 1 + 3 \left( \frac{N}{d} \right) \left( \frac{t_w}{t_f} \right)^{1.5} \right] \sqrt{EF_{yw} t_f / t_w}$$

**WHERE:**

$F_{yw}$  = specified minimum yield stress of beam web, ksi (N/mm)

$d$  = overall depth of the member, in. (mm)

$t_f$  = flange thickness, in. (mm)

If stiffeners are provided and extend at least one-half the web depth, Equations (K1-4) and (K1-5) need not be checked.

**5. Sidesway Web Buckling.** Bearing stiffeners shall be provided in the webs of members with flanges not restrained against relative movement by stiffeners or lateral bracing and subject to concentrated compressive loads, when the compressive force exceeds the following limits:

a. If the loaded flange is restrained against rotation and  $(d_c/t_w)/(l/b_f)$  is less than 2.3:

$$R = \frac{6,800t_w^3}{h} \left[ 1 + 0.4 \left( \frac{d_c/t_w}{l/b_f} \right)^3 \right] \quad (\text{K1-6})$$

$$\text{For SI:} \quad R = \frac{0.23Et_w^3}{h} \left[ 1 + 0.4 \left( \frac{d_c/t_w}{l/b_f} \right)^3 \right]$$

b. If the loaded flange is not restrained against rotation and  $(d_c/t_w)/(l/b_f)$  is less than 1.7:

$$R = \frac{6,800t_w^3}{h} \left[ 0.4 \left( \frac{d_c/t_w}{l/b_f} \right)^3 \right] \quad (\text{K1-7})$$

$$\text{For SI:} \quad R = \frac{0.23Et_w^3}{h} \left[ 0.4 \left( \frac{d_c/t_w}{l/b_f} \right)^3 \right]$$

**WHERE:**

$l$  = largest laterally unbraced length along either flange at the point of load, in. (mm)

$b_f$  = flange width, in. (mm)

$d_c$  =  $d - 2k$  = web depth clear of fillets, in. (mm)

Equations (K1-6) and (K1-7) need not be checked providing  $(d_c/t_w)/(l/b_f)$  exceeds 2.3 or 1.7, respectively, or for webs subject to uniformly distributed load.

**6. Compression Buckling of the Web.** A stiffener or a pair of stiffeners shall be provided opposite the compression flange when the web depth clear of fillets  $d_c$  is greater than

$$\frac{4,100t_{wc}^3\sqrt{F_{yc}}}{P_{bf}} \quad (\text{K1-8})$$

For SI:

$$\frac{0.14Et_{wc}^3\sqrt{F_{yc}}}{P_{bf}}$$

**WHERE:**

$t_{wc}$  = thickness of column web, in. (mm)

**7. Compression Members with Web Panels Subject to High Shear.** Members subject to high shear stress in the web should be checked for conformance with Section F4.

**8. Stiffener Requirements for Concentrated Loads.** Stiffeners shall be placed in pairs at unframed ends or at points of concentrated loads on the interior of beams, girders or columns if required by Sections K1.2 through K1.6, as applicable.

If required by Sections K1.2, K1.3 or Equation (K1-9), stiffeners need not extend more than one half the depth of the web, except as follows:

If stiffeners are required by Sections K1.4 or K1.6, the stiffeners shall be designed as axially compressed members (columns) in accordance with requirements of Section E2 with an effective length equal to  $0.75h$ , a cross section composed of two stiffeners and a strip of the web having a width of  $25t_w$  at interior stiffeners and  $12t_w$  at the ends of members.

When the load normal to the flange is tensile, the stiffeners shall be welded to the loaded flange. When the load normal to the flange is compressive, the stiffeners shall either bear on or be welded to the loaded flange.

When flanges or moment connection plates for end connections of beams and girders are welded to the flange of an I- or H-shape column, a pair of column-web stiffeners having a combined cross-sectional area  $A_{st}$  not less than that computed from Equation (K1-9) shall be provided whenever the calculated value of  $A_{st}$  is positive.

$$A_{st} = \frac{P_{bf} - F_{yc}t_{wc}(t_b + 5k)}{F_{yst}} \quad (\text{K1-9})$$

**WHERE:**

$F_{yst}$  = stiffener yield stress, ksi (N/mm<sup>2</sup>)

$k$  = distance between outer face of column flange and web toe of its fillet, if column is a rolled shape, or equivalent distance if column is a welded shape, in. (mm)

$t_b$  = thickness of flange or moment connection plate delivering concentrated force, in. (mm)

Stiffeners required by the provisions of Equation (K1-9) and Sections K1.2 and K1.6 shall comply with the following criteria:

1. The width of each stiffener plus one-half the thickness of the column web shall not be less than one third the width of the flange or moment connection plate delivering the concentrated force.

2. The thickness of stiffeners shall be not less than one half the thickness of the flange or plate delivering the concentrated load.

3. The weld joining stiffeners to the column web shall be sized to carry the force in the stiffener caused by unbalanced moments on opposite sides of the column.

**K2. PONDING**

The roof system shall be investigated by structural analysis to assure adequate strength and stability under ponding conditions, unless the roof surface is provided with sufficient slope toward points of free drainage or adequate individual drains to prevent the accumulation of rainwater.

The roof system shall be considered stable and not requiring further investigation if:

$$C_p + 0.9 C_s \leq 0.25 \quad (\text{K2-1})$$

$$\text{and } I_d \geq 25 (S^4) 10^{-6} \text{ For SI: } \times 426 \text{ 231 for mm}^4 \quad (\text{K2-2})$$

**WHERE**

$$C_p = \frac{32L_s L_p^4}{10^7 I_p}$$

$$C_s = \frac{32SL_s^4}{10^7 I_s}$$

$L_p$  = column spacing in direction of girder (length of primary members), ft. (mm)

$L_s$  = column spacing perpendicular to direction of girder (length of secondary members), ft. (mm)

$S$  = spacing of secondary members, ft. (mm)

$I_p$  = moment of inertia of primary members, in.<sup>4</sup> (mm<sup>4</sup>)

$I_s$  = moment of inertia of secondary members, in.<sup>4</sup> (mm<sup>4</sup>)

$I_d$  = moment of inertia of the steel deck supported on secondary members, in.<sup>4</sup> per ft. (mm<sup>4</sup>/m)

For trusses and steel joists, the moment of inertia  $I_s$  shall be decreased 15 percent when used in the above equation. A steel deck shall be considered a secondary member when it is directly supported by the primary members.

Total bending stress due to dead loads, gravity live loads (if any) and ponding shall not exceed  $0.80F_y$  for primary and secondary members. Stresses due to wind or seismic forces need not be included in a ponding analysis.

**K3. TORSION**

The effects of torsion shall be considered in the design of members and the normal and shearing stresses due to torsion shall be added to those from all other loads, with the resultants not exceeding the allowable values.

**K4. FATIGUE**

Members and their connections subject to fatigue loading shall be proportioned in accordance with the provisions of Appendix K4.

Few members or connections in conventional buildings need to be designed for fatigue, since most load changes in such structures occur only a small number of times or produce only minor stress fluctuations. The occurrence of full design wind or earthquake loads is too infrequent to warrant consideration in fatigue design. However, crane runways and supporting structures for machinery and equipment are often subject to fatigue loading conditions.

**CHAPTER L****SERVICEABILITY DESIGN CONSIDERATIONS**

This chapter provides design guidance for serviceability considerations not covered elsewhere. Serviceability is a state in which the function of a building, its appearance, maintainability, durability and comfort of its occupants are preserved under normal usage.

Limiting values of structural behavior to ensure serviceability (e.g., maximum deflections, accelerations, etc.) shall be chosen with due regard to the intended function of the structure.

### **L1. CAMBER**

If any special camber requirements are necessary to bring a loaded member into proper relation with the work of other trades, the requirements shall be set forth in the design documents.

Trusses of 80 feet (24 384 mm) or greater span generally shall be cambered for approximately the dead-load deflection. Crane girders of 75 feet (22 860 mm) or greater span generally shall be cambered for approximately the dead-load deflection plus one half the live-load deflection.

Beams and trusses detailed without specified camber shall be fabricated so that after erection any camber due to rolling or shop assembly shall be upward. If camber involves the erection of any member under a preload, this shall be noted in the design documents.

### **L2. EXPANSION AND CONTRACTION**

Provision shall be made for expansion and contraction appropriate to the service conditions of the structure.

### **L3. DEFLECTION, VIBRATION AND DRIFT**

**1. Deflection.** Beams and girders supporting floors and roofs shall be proportioned with due regard to the deflection produced by the design loads. Beams and girders supporting plastered ceilings shall be so proportioned that the maximum live-load deflection does not exceed  $1/360$  of the span.

**2. Vibration.** Beams and girders supporting large open floor areas free of partitions or other sources of damping shall be designed with due regard for vibration.

### **L4. CONNECTION SLIP**

For the design of slip-resistant connections see Section J3.

### **L5. CORROSION**

When appropriate, structural components shall be designed to tolerate corrosion or shall be protected against corrosion that impairs the strength or serviceability of the structure.

Where beams are exposed they shall be sealed against corrosion of interior surfaces or spaced sufficiently far apart to permit cleaning and painting.

## **CHAPTER M**

### **FABRICATION, ERECTION AND QUALITY CONTROL**

#### **M1. SHOP DRAWINGS**

Shop drawings giving complete information necessary for the fabrication of the component parts of the structure, including the location, type and size of all welds, bolts and rivets, shall be prepared in advance of the actual fabrication. These drawings shall clearly distinguish between shop and field welds and bolts and shall clearly identify type of high strength bolted connection (snug-tight or fully tightened bearing, or slip-critical).

Shop drawings shall be made in conformity with the best practice and with due regard to speed and economy in fabrication and erection.

#### **M2. FABRICATION**

**1. Cambering, Curving and Straightening.** Local application of heat or mechanical means are permitted to introduce or correct camber, curvature and straightness. The temperature of heated areas, as measured by approved methods, shall not exceed 1,050°F. (566°C.) for A852 steel, 1,100°F. (593°C.) for A514 steel nor 1,200°F. (649°C.) for other steels. The same limits apply for equivalent grades of A709 steels.

**2. Thermal Cutting.** Thermally cut free edges which will be subject to substantial tensile stress shall be free of gouges greater than  $\frac{3}{16}$  inch (4.8 mm). Gouges greater than  $\frac{3}{16}$ -inch (4.8 mm) deep and sharp notches shall be removed by grinding or repaired by welding. Thermally cut edges which are to have weld deposited upon them shall be reasonably free of notches or gouges.

All reentrant corners shall be shaped to a smooth transition. If specific contour is required, it must be shown on the contract documents.

Beam copes and weld access holes shall meet the geometrical requirements of Section J1.8. Beam copes and weld access holes in A6 Group 4 and 5 shapes and welded built-up shapes with material thickness greater than 2 inches (51 mm) shall be preheated to a temperature of not less than 150°F. (66°C.) prior to thermal cutting.

**3. Planing of Edges.** Planing or finishing of sheared or thermally cut edges of plates or shapes will not be required unless specifically called for in the design documents or included in a stipulated edge preparation for welding.

**4. Welded Construction.** The technique of welding, the workmanship, appearance and quality of welds, and the methods used in correcting nonconforming work shall be in accordance with Section 3—Workmanship and Section 4—Technique of the AWS *Structural Welding Code—Steel*, D1.1.

**5. High-strength Bolted Construction—Assembly.** All parts of bolted members shall be pinned or bolted and held together rigidly while assembling. Use of a drift pin in bolt holes during assembling shall not distort the metal or enlarge the holes. Poor matching of holes shall be cause for rejection.

If the thickness of the material is not greater than the nominal diameter of the bolt plus  $\frac{1}{8}$  inch (3.2 mm), the holes may be punched. If the thickness of the material is greater than the nominal diameter of the bolt plus  $\frac{1}{8}$  inch (3.2 mm), the holes shall be either drilled or sub-punched and reamed. The die for all sub-punched holes and the drill for all sub-drilled holes shall beat least  $\frac{1}{16}$  inch (1.6 mm) smaller than the nominal diameter of the bolt. Holes in A514 steel plates over  $\frac{1}{2}$ -inch (13 mm) thick shall be drilled.

Surfaces of high-strength-bolted parts in contact with the bolt head and nut shall not have a slope of more than 1:20 with respect to a plane normal to the bolt axis. Where the surface of a high-strength-bolted part has a slope of more than 1:20, a beveled washer shall be used to compensate for the lack of parallelism. High-strength-bolted parts shall fit solidly together when assembled and shall not be separated by gaskets or any other interposed compressible materials.

The orientation of fully inserted finger shims, with a total thickness of not more than  $\frac{1}{4}$  inch (6.4 mm) within a joint, is independent of the direction of application of the load.

When assembled, all joint surfaces, including surfaces adjacent to the bolt head and nut, shall be free of scale, except tight mill scale, and shall be free of dirt or other foreign material. Burrs that would prevent solid seating of the connected parts in the snug-tight condition shall be removed. Contact surfaces within slip-critical connections shall be free of oil, paint, lacquer or other coatings, except as listed in Table 3 of the RCSC *Specification for Structural Joints Using ASTM A325 or A490 Bolts*.

The use of high-strength bolts shall conform to the requirements of the RCSC *Specification for Structural Joints Using ASTM A325 or A490 Bolts*.

**G. Compression Joints.** Compression joints which depend on contact bearing as part of the splice capacity shall have the bearing surfaces of individual fabricated pieces prepared by milling, sawing or other suitable means.

**7. Dimensional Tolerances.** Dimensional tolerances shall be as permitted in the *Code of Standard Practice* of the American Institute of Steel Construction, Inc.

**8. Finishing of Column Bases.** Column bases and base plates shall be finished in accordance with the following requirements:

a. Rolled steel bearing plates 2 inches (51 mm) or less in thickness are permitted without milling, provided a satisfactory contact bearing is obtained; rolled steel bearing plates over 2 inches (51 mm) but not over 4 inches (102 mm) in thickness may be straightened by pressing, or if presses are not available, by milling for all bearing surfaces (except as noted in Subparagraphs c. and d. of this section), to obtain a satisfactory contact bearing; rolled steel bearing plates over 4 inches (102 mm) thick shall be milled for all bearing surfaces (except as noted in Subparagraphs c. and d. of this section).

b. Column bases other than rolled steel bearing plates shall be milled for all bearing surfaces (except as noted in Subparagraphs c. and d. of this section).

c. The bottom surfaces of bearing plates and column bases which are grouted to ensure full bearing contact on foundations need not be milled.

d. The top surfaces of base plates with columns full-penetration welded need not be pressed or milled.

### M3. SHOP PAINTING

**1. General Requirements.** Shop painting and surface preparation shall be in accordance with the provisions of the *Code of Standard Practice* of the American Institute of Steel Construction, Inc.

Unless otherwise specified, steelwork which will be concealed by interior building finish or will be in contact with concrete need not be painted. Unless specifically excluded, all other steelwork shall be given one coat of shop paint.

**2. Inaccessible Surfaces.** Except for contact surfaces, surfaces inaccessible after shop assembly shall be cleaned and painted prior to assembly, if required by the design documents.

**3. Contact Surfaces.** Paint is permitted unconditionally in bearing-type connections. For slip-critical connections, the faying surface requirements shall be in accordance with the *RCSC Specification for Structural Joints Using ASTM A325 or A490 Bolts*, paragraph 3. (b).

**4. Finished Surfaces.** Machine-finished surfaces shall be protected against corrosion by a rust-inhibiting coating that can be removed prior to erection, or which has characteristics that make removal prior to erection unnecessary.

**5. Surfaces Adjacent to Field Welds.** Unless otherwise specified in the design documents, surfaces within 2 inches (51 mm) of any field weld location shall be free of materials that would prevent proper welding or produce toxic fumes during welding.

### M4. ERECTION

**1. Alignment of Column Bases.** Column bases shall be set level and to correct elevation with full bearing on concrete or masonry.

**2. Bracing.** The frame of steel skeleton buildings shall be carried up true and plumb within the limits defined in the *Code of Standard Practice* of the American Institute of Steel Construction. Temporary bracing shall be provided, in accordance with the requirements of the *Code of Standard Practice*, wherever necessary to take care of all loads to which the structure may be subjected, including equipment and the operation of same. Such bracing shall be left in place as long as may be required for safety.

Wherever piles of material erection equipment or other loads are supported during erection, proper provision shall be made to take care of stresses resulting from such loads.

**3. Alignment.** No permanent bolting or welding shall be performed until as much of the structure as will be stiffened thereby has been properly aligned.

**4. Fit of Column Compression Joints.** Lack of contact bearing not exceeding a gap of  $1/16$  inch (1.6 mm), regardless of the type of splice used (partial-penetration, groove-welded or bolted), shall be acceptable. If the gap exceeds  $1/16$  inch (1.6 mm), but is less than  $1/4$  inch (6.4 mm), and if an

engineering investigation shows sufficient contact area does not exist, the gap shall be packed with nontapered steel shims. Shims may be of mild steel, regardless of the grade of the main material.

**5. Field Welding.** Shop paint on surfaces adjacent to welds shall be wire-brushed to reduce paint film to a minimum.

**6. Field Painting.** Responsibility for touch-up painting, cleaning and field-painting shall be allocated in accordance with accepted local practices, and this allocation shall be set forth explicitly in the design documents.

**7. Field Connections.** As erection progresses, the work shall be securely bolted or welded to take care of all dead load, wind and erection stresses.

## M5. QUALITY CONTROL

The fabricator shall provide quality control procedures to the extent that he deems necessary to assure that all work is performed in accordance with this Specification. In addition to the fabricator's quality control procedures, material and workmanship at all times may be subject to inspection by qualified inspectors representing the purchaser. If such inspection by representatives of the purchaser will be required, it shall be so stated in design documents.

**1. Cooperation.** As far as possible, all inspection by representatives of the purchaser shall be made at the fabricator's plant. The fabricator shall cooperate with the inspector, permitting access for inspection to all places where work is being done. The purchaser's inspector shall schedule his work for minimum interruption to the work of the fabricator.

**2. Rejections.** Material or workmanship not in reasonable conformance with the provisions of this Specification may be rejected at any time during the progress of the work. The fabricator shall receive copies of all reports furnished to the purchaser by the inspection agency.

**3. Inspection of Welding.** The inspection of welding shall be performed in accordance with Section 6 of the *AWS Structural Welding Code—Steel, D1.1*.

When nondestructive testing is required, the process, extent and standards of acceptance shall be defined clearly in the design documents.

**4. Inspection of Slip-critical, High-strength Bolted Connections.** The inspection of slip-critical, high-strength bolted connections shall be in accordance with the provisions of the *RCSC Allowable Stress Design Specification for Structural Joints Using ASTM A325 or A490 Bolts*.

**5. Identification of Steel.** The fabricator shall be able to demonstrate by a written procedure and by actual practice a method of material application and identification, visible at least through the "fit-up" operation, of the main structural elements of a shipping piece.

The identification method shall be capable of verifying proper material application as it relates to:

1. Material specification designation;
2. Heat number, if required;
3. Material test reports for special requirements.

## CHAPTER N

### PLASTIC DESIGN

#### N1. SCOPE

Subject to the limitations contained herein, simple and continuous beams, braced and unbraced planar rigid frames, and similar parts of structures rigidly constructed so as to be continuous over at

least one interior support,\* are permitted to be proportioned on the basis of plastic design, i.e., on the basis of their maximum strength. This strength, as determined by rational analysis, shall not be less than that required to support a factored load equal to 1.7 times the given live load and dead load, or 1.3 times these loads acting in conjunction with 1.3 times any specified wind or earthquake forces.

Rigid frames shall satisfy the requirements for Type I construction in the plane of the frame, as provided in Section A2.2. This does not preclude the use of some simple connections, provided provisions of Section N3 are satisfied. Type 2 construction is permitted for members between rigid frames. Connections joining a portion of a structure designed on the basis of plastic behavior with a portion not so designed need be no more rigid than ordinary seat-and-top-angle or ordinary web connections.

Where plastic design is used as the basis for proportioning continuous beams and structural frames, the provisions relating to allowable stress are waived. Except as modified by these rules, however, all other pertinent provisions of Chapters A through M shall govern.

Crane runways shall not be designed continuous over interior vertical supports on the basis of maximum strength. However, rigid frame bents supporting crane runways may be considered as coming within the scope of the rules.

## N2. STRUCTURAL STEEL

Structural steel shall conform to one of the following specifications:

A36, A242, A441, A529, A572 and A588.

## N3. BASIS FOR MAXIMUM STRENGTH DETERMINATION

For one- or two-story frames, the maximum strength is permitted to be determined by a routine plastic analysis procedure and ignoring the frame instability effect ( $P\Delta$ ). For braced multistory frames, provisions shall be made to include the frame instability effect in the design of bracing system and frame members. For unbraced multistory frames, the frame instability effect shall be included directly in the calculations for maximum strength.

**1. Stability of Braced Frames.** The vertical bracing system for a plastically designed braced multistory frame shall be adequate, as determined by an analysis, to:

1. Prevent buckling of the structure under factored gravity loads.
2. Maintain the lateral stability of the structure, including the overturning effects of drift, under factored gravity plus factored horizontal loads.

It is permitted to consider that the vertical bracing system functions together with inplane shear-resisting exterior and interior walls, floor slabs and roof decks, if these walls, slabs and decks are secured to the structural frames. The columns, girders, beams and diagonal members, when used as the vertical bracing system, could be considered to comprise a vertical-cantilever, simply connected truss in the analyses for frame buckling and lateral stability. Axial deformation of all members in the vertical bracing system shall be included in the lateral stability analysis. The axial force in these members caused by factored gravity plus factored horizontal loads shall not exceed  $0.85P_y$ , where  $P_y$  is the product of yield stress times the profile area of the member.

Girders and beams included in the vertical bracing system of a braced multistory frame shall be proportioned for axial force and moment caused by the concurrent factored horizontal and gravity loads, in accordance with Equation (N4-2), with  $P_{cr}$ , taken as the maximum axial strength of the beam, based on the actual slenderness ratio between braced points in the plane of bending.

**2. Stability of Unbraced Frames.** The strength of an unbraced multistory frame shall be determined by an analysis which includes the effect of frame instability and column axial deformation.

---

\*As used here, "interior support" includes a rigid-frame knee formed by the junction of a column and a sloping or horizontal beam or girder.

Such a frame shall be designed to be stable under (1) factored gravity loads and (2) factored gravity loads plus factored horizontal loads. The axial force in the columns at factored load levels shall not exceed  $0.75P_y$ .

#### N4. COLUMNS

In the plane of bending of columns which would develop a plastic hinge at ultimate loading, the slenderness ratio  $l/r$  shall not exceed  $C_c$ , as defined in Section E2.

The maximum strength of an axially loaded compression member shall be taken as

$$P_{cr} = 1.7F_aA \quad (\text{N4-1})$$

where  $A$  is the gross area of the member and  $F_a$ , as defined by Equation (E2-1), is based upon the applicable slenderness ratio.

Members subject to combined axial load and bending moment shall be proportioned to satisfy the following interaction formulas:

$$\frac{P}{P_{cr}} + \frac{C_m M}{\left(1 - \frac{P}{P_e}\right) M_m} \leq 1.0 \quad (\text{N4-2})$$

$$\frac{P}{P_y} + \frac{M}{1.18M_p} \leq 1.0; M \leq M_p \quad (\text{N4-3})$$

#### WHERE:

$M$  = maximum factored moment, kip-ft (N·mm)

$P$  = factored axial load, kips (N)

$P_e$  = Euler buckling load, kips (N)

=  $(23/12)F'_c A$ , where  $F'_c$  is as defined in Section H1.

$C_m$  = coefficient defined in Section H1.

$M_m$  = maximum moment that can be resisted by the member in the absence of axial load, kip-ft

$M_p$  = plastic moment, kip-ft (N·mm)

=  $F_y Z$

$Z$  = plastic section modulus, in. (mm)

For columns braced in the weak direction:

$$M_m = M_{px} \quad (\text{N4-4})$$

For columns unbraced in the weak direction:

$$M_m = \left[ 1.07 - \frac{(l/r_y)\sqrt{F_y}}{3160} \right] M_{px} \leq M_{px} \quad (\text{N4-5})$$

For SI:

$$M_m = \left[ 1.07 - \frac{(l/r_y)\sqrt{F_y}}{18.56\sqrt{E}} \right] M_{px} \leq M_{px}$$

#### N5. SHEAR

Unless reinforced by diagonal stiffeners or a doubler plate, the webs of columns, beams and girders, including areas within the boundaries of the connections, shall be so proportioned that

$$V \leq 0.55F_y t_w d \quad (\text{N5-1})$$

#### WHERE:

$V$  = shear that would be produced by the required factored loading, kips (N)

$d$  = depth of the member, in. (mm)  
 $t_w$  = web thickness, in. (mm)

### N6. WEB CRIPPLING

Web stiffeners are required on a member at a point of load application where a plastic hinge would form.

At points on a member where the concentrated load delivered by the flanges of a member framing into it would produce web crippling opposite the compression flange or high-tensile stress in the connection of the tension flange, web stiffeners are required in accordance with the provisions of Section K1.

### N7. MINIMUM THICKNESS (WIDTH-THICKNESS RATIOS)

The width-thickness ratio for flanges of rolled W, M or S shapes and similar built-up, single-web shapes subjected to compression involving hinge rotation under ultimate loading shall not exceed the following values:

$F_y$ (ksi)	$F_y$ (N/mm <sup>2</sup> )	$b_f/2t_f$
36	248	8.5
42	289	8.0
45	310	7.4
50	345	7.0
55	379	6.6
60	413	6.3
65	448	6.0

It is permitted to take the thickness of sloping flanges as their average thickness.

The width-thickness ratio of similarly compressed flange plates in box sections and cover plates shall not exceed  $190/\sqrt{F_y}$  (For SI:  $1.12\sqrt{E/F_y}$ ). For this purpose, the width of a cover plate shall be taken as the distance between longitudinal lines of connecting rivets, high-strength bolts or welds.

The depth-thickness ratio of webs of members subject to plastic bending shall not exceed the value given by Equation (N7-1) or (N7-2), as applicable.

$$\frac{d}{t} = \frac{412}{\sqrt{F_y}} \left( 1 - 1.4 \frac{P}{P_y} \right) \text{ when } \frac{P}{P_y} \leq 0.27 \quad (\text{N7-1})$$

For SI: 
$$\frac{d}{t} = 2.42 \sqrt{\frac{E}{F_y}} \left( 1 - 1.4 \frac{P}{P_y} \right)$$

$$\frac{d}{t} = \frac{257}{\sqrt{F_y}} \text{ when } \frac{P}{P_y} > 0.27 \quad (\text{N7-2})$$

For SI: 
$$\frac{d}{t} = 1.51 \sqrt{\frac{E}{F_y}} \text{ when } \frac{P}{P_y} > 0.27$$

### N8. CONNECTIONS

All connections, the rigidity of which is essential to the continuity assumed as the basis of the analysis, shall be capable of resisting the moments, shears and axial loads to which they would be subjected by the full factored loading, or any probable partial distribution thereof.

Corner connections (haunches) that are tapered or curved for architectural reasons shall be so proportioned that the full plastic bending strength of the section adjacent to the connection can be developed, if required.

Stiffeners shall be used, as required, to preserve the flange continuity of interrupted members at their junction with other members in a continuous frame. Such stiffeners shall be placed in pairs on opposite sides of the web of the member which extends continuously through the joint.

High-strength bolts, A307 bolts, rivets and welds shall be proportioned to resist the forces produced at factored load, using stresses equal to 1.7 times those given in Chapters A through M. In general, groove welds are preferable to fillet welds, but their use is not mandatory.

High-strength bolts are permitted in joints having painted contact surfaces when these joints are of such size that the slip required to produce bearing would not interfere with the formation, at factored loading, of the plastic hinges assumed in the design.

### N9. LATERAL BRACING

Members shall be braced adequately to resist lateral and torsional displacements at the plastic hinge locations associated with the failure mechanism. The laterally unsupported distance  $l_{cr}$  from such braced hinge locations to similarly braced adjacent points on the member or frame shall not exceed the value determined from Equation (N9-1) or (N9-2), as applicable.

$$\frac{l_{cr}}{r_y} = \frac{1,375}{F_y} + 25 \text{ when } +1.0 > \frac{M}{M_p} > -0.5 \quad (\text{N9-1})$$

For SI: 
$$\frac{l_{cr}}{r_y} = \frac{9474}{F_y} + 25 \text{ when } +1.0 > \frac{M}{M_p} > -0.5$$

$$\frac{l_{cr}}{r_y} = \frac{1,375}{F_y} \text{ when } -0.5 \geq \frac{M}{M_p} > -1.0 \quad (\text{N9-2})$$

For SI: 
$$\frac{l_{cr}}{r_y} = \frac{9474}{F_y} \text{ when } -0.5 \geq \frac{M}{M_p} > -1.0$$

#### WHERE:

$r_y$  = radius of gyration of the member about its weak axis, in. (mm)

$M$  = lesser of the moments at the ends of the unbraced segment, kip-ft. (N•mm)

$M/M_p$  = end moment ratio, positive when the segment is bent in reverse curvature and negative when bent in single curvature

The foregoing provisions need not apply in the region of the last hinge to form in the failure mechanism assumed as the basis for proportioning a given member, nor in members oriented with their weak axis normal to the plane of bending. However, in the region of the last hinge to form, and in regions not adjacent to a plastic hinge, the maximum distance between points of lateral support shall be such as to satisfy the requirements of Equations (F1-5), (F1-6), or (F1-7), as well as Equations (H1-1) and (H1-2). For this case, the values of  $f_a$  and  $f_a$  shall be computed from the moment and axial force at factored loading, divided by the applicable load factor.

Members built into a masonry wall and having their web perpendicular to this wall can be assumed to be laterally supported with respect to their weak axis of bending.

### N10. FABRICATION

The provisions of Chapters A through M with respect to workmanship shall govern the fabrication of structures, or portions of structures, designed on the basis of maximum strength, subject to the following limitations:

1. The use of sheared edges shall be avoided in locations subject to plastic hinge rotation at factored loading. If used, they shall be finished smooth by grinding, chipping or planing.
2. In locations subject to plastic hinge rotation at factored loading, holes for rivets or bolts in the tension area shall be sub-punched and reamed or drilled full size.

## APPENDIX B DESIGN REQUIREMENTS

### B5. LOCAL BUCKLING

**2. Slender Compression Elements.** Axially loaded members and flexural members containing elements subject to compression which have a width-thickness ratio in excess of the applicable noncompact value, as stipulated in Section B5.1 shall be proportioned according to this Appendix.

**a. Unstiffened Compression Elements.** The allowable stress of unstiffened compression elements whose width-thickness ratio exceeds the applicable noncompact value as stipulated in Section B5.1 shall be subject to a reduction factor  $Q_s$ . The value of  $Q_s$  shall be determined by Equations (A-B5-1) through (A-B5-6), as applicable, where  $b$  is the width of the unstiffened element as defined in Section B5.1. When such elements comprise the compression flange of a flexural member, the maximum allowable bending stress shall not exceed  $0.60 F_y Q_s$  nor the applicable value as provided in Section F1.3. The allowable stress of axially loaded compression members shall be modified by the appropriate reduction factor  $Q$ , as provided in paragraph c.

For single angles:

$$\text{When } 76.0/\sqrt{F_y} < b/t < 155/\sqrt{F_y} : \quad (\text{A-B5-1})$$

$$Q_s = 1.340 - 0.00447(b/t)\sqrt{F_y}$$

$$\text{For SI: When } 0.45\sqrt{E/F_y} < b/t < 0.91\sqrt{E/F_y} :$$

$$Q_s = 1.340 - 0.76(b/t)\sqrt{F_y/E}$$

$$\text{When } b/t \geq 155/\sqrt{F_y} : \quad (\text{A-B5-2})$$

$$Q_s = 15,500/[F_y(b/t)^2]$$

$$\text{For SI: When } b/t \geq 0.91\sqrt{E/F_y} :$$

$$Q_s = 0.53E/[F_y(b/t)^2]$$

For angles or plates projecting from columns or other compression members, and for projecting elements of compression flanges of beams and girders:

$$\text{When } 95.0/\sqrt{F_y/k_c} < b/t < 195/\sqrt{F_y/k_c} : \quad (\text{A-B5-3})$$

$$Q_s = 1.293 - 0.00309(b/t)\sqrt{F_y/k_c}$$

$$\text{For SI: When } 0.56\sqrt{E/F_y/k_c} < b/t < 1.15\sqrt{E/(F_y/k_c)}$$

$$Q_s = 1.293 - 0.53(b/t)\sqrt{F_y/Ek_c}$$

$$\text{When } b/t > 195/\sqrt{F_y/k_c} : \quad (\text{A-B5-4})$$

$$Q_s = 26,200k_c/[F_y(b/t)^2]$$

For SI: When  $b/t > 1.15\sqrt{E/(F_y/k_c)}$   
 $Q_s = 0.90Ek_c/[F_y(b/t)^2]$

For stems of tees:

When  $127/\sqrt{F_y} < b/t < 176/\sqrt{F_y}$  : (A-B5-5)  
 $Q_s = 1.908 - 0.00715(b/t)\sqrt{F_y}$

For SI: When  $0.75\sqrt{E/F_y} < b/t < 1.04\sqrt{E/F_y}$  :  
 $Q_s = 1.908 - 1.22(b/t)\sqrt{F_y/E}$

When  $b/t > 176/\sqrt{F_y}$  : (A-B5-6)  
 $Q_s = 20,000/[F_y(b/t)^2]$

For SI: When  $b/t > 1.04\sqrt{E/F_y}$   
 $Q_s = 0.69E/[F_y(b/t)^2]$

**WHERE:**

$b$  = width of unstiffened compression element as defined in Section B5.1

$t$  = thickness of unstiffened element, in. (mm)

$F_y$  = specified minimum yield stress, ksi (N/mm<sup>2</sup>)

$k_c = \frac{4.05}{(h/t)^{46}}$  if  $h/t > 70$ , otherwise  $k_c = 1.0$

Unstiffened elements of tees whose proportions exceed the limits of Section B5.1 shall conform to the limits given in Table A-B5.1.

**b. Stiffened Compression Elements.** When the width-thickness ratio of uniformly compressed stiffened elements (except perforated cover plates) exceeds the noncompact limit stipulated in Section B5.1, a reduced effective width  $b_e$  shall be used in computing the design properties of the section containing the element, except that the ratio  $b_e/t$  need not be taken as less than the applicable value permitted in Section B5.1.

For the flanges of square and rectangular sections of uniform thickness:

$$b_e = \frac{253t}{\sqrt{f}} \left[ 1 - \frac{50.3}{(b/t)\sqrt{f}} \right] \leq b \quad (\text{A-B5-7})$$

For SI:  $b_e = 1.49t \sqrt{\frac{E}{f}} \left[ 1 - \frac{0.30}{(b/t)\sqrt{\frac{E}{f}}} \right] \leq b$

For other uniformly compressed elements:

$$b_e = \frac{253t}{\sqrt{f}} \left[ 1 - \frac{44.3}{(b/t)\sqrt{f}} \right] \leq b \quad (\text{A-B5-8})$$

For SI: 
$$b_e = 1.49t \sqrt{\frac{E}{f}} \left[ 1 - \frac{0.26}{(b/t)} \sqrt{\frac{E}{f}} \right] \leq b$$

**WHERE:**

- $b$  = actual width of a stiffened compression element, as defined in Section B5.1, in. (mm)
- $b_e$  = reduced width, in. (mm)
- $t$  = element thickness, in. (mm)
- $f$  = computed compressive stress (axial plus bending stresses) in the stiffened elements, based on the design properties as specified in Appendix B5.2, ksi (N/mm<sup>2</sup>). If unstiffened elements are included in the total cross section,  $f$  for the stiffened element must be such that the maximum compressive stress in the unstiffened element does not exceed  $F_a Q_s$  or  $F_b Q_s$ , as applicable.

**TABLE A-B5.1**  
Limiting Proportions for Channels and Tees

Shape	Ratio of full flange width to profile depth	Ratio of flange thickness to web or stem thickness
Built-up or rolled channels	≤ 0.25	≤ 3.0
	≤ 0.50	≤ 2.0
Built-up tees	≥ 0.50	≥ 1.25
Rolled tees	≥ 0.50	≥ 1.10

When the allowable stresses are increased due to wind or seismic loading in accordance with the provisions of Section A5.2, the effective width  $b_e$  shall be determined on the basis of 0.75 times the stress caused by wind or seismic loading acting alone or in combination with the design dead and live loading.

For axially loaded circular sections:

Members with diameter-to-thickness ratios  $D/t$  greater than  $3,300/F_y$  [For SI:  $(22\ 737)/F_y$ ], but having a diameter-to-thickness ratio of less than  $13,000/F_y$  [For SI:  $(89\ 570)/F_y$ ], shall not exceed the smaller value determined by Section E2 nor

$$F_a = \frac{662}{D/t} + 0.40F_y \quad (\text{A-B5-9})$$

**WHERE:**

- $D$  = outside diameter, in. (mm)
- $t$  = wall thickness, in. (mm)

**c. Design Properties.** Properties of sections shall be determined using the full cross section, except as follows:

In computing the moment of inertia and section modulus of flexural members, the effective width of uniformly compressed stiffened elements, as determined in Appendix B5.2b, shall be used in determining effective cross-sectional properties.

For stiffened elements of the cross section

$$Q_a = \frac{\text{effective area}}{\text{actual area}} \quad (\text{A-B5-10})$$

For unstiffened elements of the cross section,  $Q_s$  is determined from Appendix B5.2a.

For axially loaded compression members the gross cross-sectional area and the radius of gyration  $r$  shall be computed on the basis of the actual cross section.

The allowable stress for axially loaded compression members containing unstiffened or stiffened elements shall not exceed

$$F_a = \frac{Q \left[ 1 - \frac{(Kl/r)^2}{2C'_c{}^2} \right] F_y}{\frac{5}{3} + \frac{3(Kl/r)}{8C'_c} - \frac{(Kl/r)^3}{8C'_c{}^3}} \quad (\text{A-B5-11})$$

when  $Kl/r$  is less than  $C'_c$ , where

$$C'_c = \sqrt{\frac{2\pi^2 E}{QF_y}}$$

and

$$Q = Q_s Q_a$$

a. Cross sections composed entirely of unstiffened elements,

$$Q = Q_s \text{ i.e. } (Q_a = 1.0)$$

b. Cross sections composed entirely of stiffened elements,

$$Q = Q_a \text{ i.e. } (Q_s = 1.0)$$

c. Cross sections composed of both stiffened and unstiffened elements,

$$Q = Q_s Q_a$$

When  $Kl/r$  exceeds  $C'_c$ :

$$F_a = \frac{12\pi^2 E}{23(Kl/r)^2} \quad (\text{A-B5-12})$$

**d. Combined Axial and Flexural Stress.** In applying the provisions of Chapter H to members subject to combined axial and flexural stress and containing stiffened elements whose width-thickness ratio exceeds the applicable noncompact limit given in Section B5.1, the stresses  $F_a$ ,  $f_{bx}$  and  $f_{by}$  shall be calculated on the basis of the section properties as provided in Appendix B5.2c, as applicable. The allowable bending stress  $F_b$  for members containing unstiffened elements whose width-thickness ratio exceeds the noncompact limit given in Section B5.1 shall be the smaller value,  $0.60F_y Q_s$ , or that provided in Section F1.3. The term  $f_a/0.60F_y$  in Equations (H1-2) and (A-F7-13) shall be replaced by  $f_a/0.60F_y Q$ .

## APPENDIX F

### BEAMS AND OTHER FLEXURAL MEMBERS

#### F7. WEB-TAPERED MEMBERS

The design of tapered members meeting the requirements of this section shall be governed by the provisions of Chapter F, except as modified by this Appendix.

**1. General Requirements.** In order to qualify under this Specification, a tapered member must meet the following requirements:

a. It shall possess at least one axis of symmetry which shall be perpendicular to the plane of bending if moments are present.

b. The flanges shall be of equal and constant area.

c. The depth shall vary linearly as

$$d = d_o \left( 1 + \gamma \frac{z}{L} \right) \quad (\text{A-F7-1})$$

**WHERE:**

- $d_o$  = depth at smaller end of member, in. (mm)
- $d_L$  = depth at larger end of member, in. (mm)
- $\gamma = (d_L - d_o)/d_o \leq$  the smaller of 0.268 ( $L/d_o$ ) or 6.0
- $z$  = distance from the smaller end of member, in. (mm)
- $L$  = unbraced length of member measured between the center of gravity of the bracing members, in. (mm)

**2. Allowable Tensile Stress.** The allowable tensile stress of tapered tension members shall be determined in accordance with Section D1.

**3. Allowable Compressive Stress.** On the gross section of axially loaded tapered compression members, the allowable compressive stress, in kips per square inch, shall not exceed the following:

$$F_{ay} = \frac{\left( 1.0 - \frac{S^2}{2C_c^2} \right) F_y}{\frac{5}{3} + \frac{3S}{8C_c} - \frac{S^3}{8C_c^3}} \quad (\text{A-F7-2})$$

When the effective slenderness ratio  $S$  exceeds  $C_c$ :

$$F_{ay} = \frac{12\pi^2 E}{23S^2} \quad (\text{A-F7-3})$$

**WHERE**

- $S = Kl/r_{oy}$  for weak axis bending and  $K_y l/r_{ox}$  for strong axis bending
- $K$  = effective length factor for a prismatic member
- $K_y$  = effective length factor for a tapered member as determined by an analysis
- $l$  = actual unbraced length of member, in. (mm)
- $r_{ox}$  = strong axis radius of gyration at the smaller end of a tapered member, in. (mm)
- $r_{oy}$  = weak axis radius of gyration at the smaller end of a tapered member, in. (mm)

**4. Allowable Flexural Stress.** Tension and compression stresses on extreme fibers of tapered flexural members, in kips per square inch ( $\text{N/mm}^2$ ), shall not exceed the following values:

$$F_{by} = \frac{2}{3} \left[ 1.0 - \frac{F_y}{6B \sqrt{F_{sy}^2 + F_{wy}^2}} \right] F_2 \leq 0.60F_y \quad (\text{A-F7-4})$$

unless  $F_{by} < F_y/3$ , in which case

$$F_{by} = B \sqrt{F_{sy}^2 + F_{wy}^2} \quad (\text{A-F7-5})$$

In the above equations,

$$F_{sy} = \frac{12 \times 10^3}{h_s L d_o / A_f} \quad (\text{A-F7-6})$$

For SI:

$$F_{sy} = \frac{82\,680}{h_s L d_o / A_f}$$

$$F_{w\gamma} = \frac{170 \times 10^3}{(h_w L/r_{T0})^2} \quad (\text{A-F7-7})$$

For SI: 
$$F_{w\gamma} = \frac{1\ 171\ 300}{(h_w L/r_{T0})^2}$$

**WHERE:**

$h_s$  = factor equal to  $1.0 + 0.0230\gamma \sqrt{Ld_o/A_f}$

$h_w$  = factor equal to  $1.0 + 0.00385 \sqrt{L/r_{T0}}$

$r_{T0}$  = radius of gyration to a section at the smaller end, considering only the compression flange plus one third of the compression web area, taken about an axis in the plane of the web, in. (mm)

$A_f$  = area of the compression flange, in.<sup>2</sup> (mm<sup>2</sup>)

and where  $B$  is determined as follows:

a. When the maximum moment  $M_2$  in three adjacent segments of approximately equal unbraced length is located within the central segment and  $M_1$  is the larger moment at one end of the three-segment portion of a member:\*

$$B = 1.0 + 0.37\left(1.0 + \frac{M_1}{M_2}\right) + 0.50\gamma\left(1.0 + \frac{M_1}{M_2}\right) \geq 1.0 \quad (\text{A-F7-8})$$

b. When the largest computed bending stress  $f_{b2}$  occurs at the larger end of two adjacent segments of approximately equal unbraced lengths and  $f_{b1}$  is the computed bending stress at the smaller end of the two-segment portion of a member:\*

$$B = 1.0 + 0.58\left(1.0 + \frac{f_{b1}}{f_{b2}}\right) - 0.70\gamma\left(1.0 + \frac{f_{b1}}{f_{b2}}\right) \geq 1.0 \quad (\text{A-F7-9})$$

c. When the largest computed bending stress  $f_{b2}$  occurs at the smaller end of two adjacent segments of approximately equal unbraced length and  $f_{b1}$  is the computed bending stress at the larger end of the two-segment portion of a member:\*\*

$$B = 1.0 + 0.55\left(1.0 + \frac{f_{b1}}{f_{b2}}\right) + 2.20\gamma\left(1.0 + \frac{f_{b1}}{f_{b2}}\right) \geq 1.0 \quad (\text{A-F7-10})$$

In the foregoing,  $\gamma = (d_L - d_o)/d_o$  is calculated for the unbraced length containing the maximum computed bending stress.

d. When the computed bending stress at the smaller end of a tapered member or segment thereof is equal to zero:

$$B = \frac{1.75}{1.0 + 0.25\sqrt{\gamma}} \quad (\text{A-F7-11})$$

where  $\gamma = (d_L - d_o)/d_o$  calculated for the unbraced length adjacent to the point of zero bending stress.

**5. Allowable Shear.** The allowable shear stress of tapered flexural members shall be in accordance with Section F4.

**6. Combined Flexure and Axial Force.** Tapered members and unbraced segments thereof subjected to both axial compression and bending stresses shall be proportioned to satisfy the following requirement:

\* $M_1/M_2$  is considered as negative when producing single curvature. In the rare case where  $M_1/M_2$  is positive, it is recommended it be taken as zero.

\*\* $f_{b1}/f_{b2}$  is considered as negative when producing single curvature. If a point of contraflexure occurs in one of two adjacent unbraced segments,  $f_{b1}/f_{b2}$  is considered as positive. The ratio  $f_{b1}/f_{b2} = 0$ .

$$\left(\frac{F_{ao}}{F_{ay}}\right) + \frac{C'_m}{\left(1 - \frac{F_{ao}}{F'_{ey}}\right)} \left(\frac{f_{bl}}{F'_{by}}\right) \leq 1.0 \quad (\text{A-F7-12})$$

$$\frac{f_a}{0.60F_y} + \frac{f_b}{F_{by}} \leq 1.0 \quad (\text{A-F7-13})$$

When  $f_{ao}/F_{ay} < 0.15$ , Equation (A-F7-14) is permitted in lieu of Equations (A-F7-12) and (A-F7-13).

$$\left(\frac{f_a}{F_{ay}}\right) + \left(\frac{f_b}{F_{by}}\right) \leq 1.0 \quad (\text{A-F7-14})$$

**WHERE:**

$F_{ay}$  = axial compressive stress permitted in the absence of bending moment, ksi (N/mm<sup>2</sup>)

$F_{by}$  = bending stress permitted in the absence of axial force, ksi (N/mm<sup>2</sup>)

$F'_{ey}$  = Euler stress divided by factor of safety, ksi (N/mm<sup>2</sup>), equal to

$$\frac{12\pi^2 E}{23(K_y l_b / r_{bo})^2}$$

where  $l_b$  is the actual unbraced length in the plane of bending and  $r_{bo}$  is the corresponding radius of gyration at its smaller end

$f_{ao}$  = computed axial stress at the smaller end of the member or unbraced segment thereof, as applicable, ksi (N/mm<sup>2</sup>)

$f_{bl}$  = computed bending stress at the larger end of the member or unbraced segment thereof, as applicable, ksi (N/mm<sup>2</sup>)

$C'_m$  = coefficient applied to bending term in interaction equation

$$= 1.0 + 0.1 \left(\frac{f_{ao}}{F'_{ey}}\right) + 0.6 \left(\frac{f_{ao}}{F'_{ey}}\right)^2$$

when the member is subjected to end moments which cause single curvature bending and approximately equal computed bending stresses at the ends

$$= 1.0 + 0.9 \left(\frac{f_{ao}}{F'_{ey}}\right) + 0.6 \left(\frac{f_{ao}}{F'_{ey}}\right)^2$$

when the computed bending stress at the smaller end of the unbraced length is equal to zero.

When  $Kl/r \geq C_c$  and combined stresses are checked incrementally along the length,  $f_{ao}$  may be replaced by  $f_a$  and  $f_{bl}$  may be replaced by  $f_b$ , in Equations (A-F7-12) and (A-F7-14).

## APPENDIX K

### STRENGTH DESIGN CONSIDERATIONS

#### K4. FATIGUE

Members and connections subject to fatigue loading shall be proportioned in accordance with the provisions of this Appendix.

Fatigue, as used in this Specification, is defined as the damage that may result in fracture after a sufficient number of fluctuations of stress. Stress range is defined as the magnitude of these fluctuations. In the case of a stress reversal, the stress range shall be computed as the numerical sum of maximum repeated tensile and compressive stresses or the sum of maximum shearing stresses of opposite direction at a given point, resulting from differing arrangement of live load.

**1. Loading Conditions; Type and Location of Material.** In the design of members and connections subject to repeated variation of live load, consideration shall be given to the number of stress cycles, the expected range of stress and the type and location of member or detail.

Loading conditions shall be classified according to Table A-K4.1.

The type and location of material shall be categorized according to Table A-K4.2.

**2. Allowable Stress Range.** The maximum stress shall not exceed the basic allowable stress provided in Chapters A through M of this Specification and the maximum range of stress shall not exceed that given in Table A-K4.1.

**TABLE A-K4.1**  
**Number of Loading Cycles**

Loading Condition	From	To
1	20,000 <sup>a</sup>	100,000 <sup>b</sup>
2	100,000	500,000 <sup>c</sup>
3	500,000	2,000,000 <sup>d</sup>
4	Over 2,000,000	

<sup>a</sup>Approximately equivalent to two applications every day for 25 years.  
<sup>b</sup>Approximately equivalent to 10 applications every day for 25 years.  
<sup>c</sup>Approximately equivalent to 50 applications every day for 25 years.  
<sup>d</sup>Approximately equivalent to 200 applications every day for 25 years.

**3. Tensile Fatigue.** When subject to tensile fatigue loading, the tensile stress in A325 or A490 bolts due to the combined applied load and prying forces shall not exceed the following values, and the prying force shall not exceed 60 percent of the externally applied load.

Number of Cycles	(ksi) (N/mm <sup>2</sup> )	(ksi) (N/mm <sup>2</sup> )
Not more than 20,000	44 (303)	54 (372)
From 20,000 to 500,000	40 (276)	49 (338)
More than 500,000	31 (214)	38 (262)

Bolts must be tensioned to the requirements of Table J3.7.

The use of other bolts and threaded parts subjected to tensile fatigue loading is not permitted.

TABLE A-K4.2  
Stress Category Classifications

General Condition	Situation	Kind of Stress <sup>a</sup>	Stress Category (see Table A-K4.3)	Illustrative Example Nos. (see Fig. A-K4.1) <sup>b</sup>
Plain Material	Base metal with rolled or cleaned surface. Flame-cut edges with ANSI smoothness of 1,000 or less	T or Rev.	A	1, 2
Built-up Members	Base metal in members without attachments, built-up plates or shapes connected by continuous full-penetration groove welds or by continuous fillet welds parallel to the direction of applied stress	T or Rev.	B	3, 4, 5, 6
	Base metal in members without attachments, built-up plates, or shapes connected by full-penetration groove welds with backing bars not removed, or by partial-penetration groove welds parallel to the direction of applied stress	T or Rev.	B'	3, 4, 5, 6
	Base metal at toe of welds on girder webs or flanges adjacent to welded transverse stiffeners	T or Rev.	C	7
	Base metal at ends of partial length welded cover plates narrower than the flange having square or tapered ends, with or without welds across the ends or wider than flange with welds across the ends Flange thickness $\leq 0.8$ in. (20 mm) Flange thickness $> 0.8$ in. (20 mm)	T or Rev. T or Rev.	E E'	5 5
	Base metal at end of partial length welded cover plates wider than the flange without welds across the ends		E'	5
Groove Welds	Base metal and weld metal at full-penetration groove welded splices of parts of similar cross section ground flush, with grinding in the direction of applied stress and with weld soundness established by weld soundness established by radiographic or ultrasonic inspection in accordance with the requirements of 9.25.2 or 9.25.3 of AWS D1.1	T or Rev.	B	10, 11
	Base metal and weld metal at full-penetration groove welded splices at transitions in width or thickness, with welds ground to provide slopes no steeper than 1 to 2 $\frac{1}{2}$ with grinding in the direction of applied stress, and with weld soundness established by radiographic or ultrasonic inspection in accordance with the requirements of 9.25.2 or 9.25.3 of AWS D1.1 A514 base metal Other base metals	T or Rev. T or Rev.	B' B	12, 13 12, 13
	Base metal and weld metal at full-penetration groove welded splices, with or without transitions having slopes no greater than 1 to 2 $\frac{1}{2}$ when reinforcement is not removed but weld soundness is established by radiographic or ultrasonic inspection in accordance with requirements of 9.25.2 or 9.25.3 of AWS D1.1	T or Rev.	C	10, 11, 12, 13

(Continued)

TABLE A-K4.2  
Stress Category Classifications—Continued

General Condition	Situation	Kind of Stress <sup>a</sup>	Stress Category (see Table A-K4.3)	Illustrative Example Nos. (see Fig. A-K4.1) <sup>b</sup>
Partial-penetration Groove Welds	Weld metal of partial-penetration transverse groove welds, based on effective throat area of the weld or welds	T or Rev.	F <sup>c</sup>	16
Fillet-welded Connections	Base metal at intermittent fillet welds	T or Rev.	E	
	Base metal at junction of axially loaded members with fillet-welded end connections. Welds shall be disposed about the axis of the member so as to balance weld stresses $b \leq 1$ in. (25 mm) $b > 1$ in. (25 mm)	T or Rev. T or Rev.	E E'	17, 18 17, 18
	Base metal at members connected with transverse fillet welds $b \leq 1/2$ in. (13 mm) $b > 1/2$ in. (13mm)	T or Rev.	C See Note <sup>c</sup>	20, 21
Fillet Welds	Weld metal of continuous or intermittent longitudinal or transverse fillet welds	S	F <sup>c</sup>	15, 17, 18, 20, 21
Plug or Slot Welds	Base metal at plug or slot welds	T or Rev.	E	27
	Shear on plug or slot welds	S	F	27
Mechanically Fastened Connections	Base metal at gross section of high-strength bolted slip-critical connections, except axially loaded joints which induce out-of-plane bending in connected material	T or Rev.	B	8
	Base metal at net section of other mechanically fastened joints	T or Rev.	D	8, 9
	Base metal at net section of fully tensioned high-strength, bolted-bearing connections	T or Rev.	B	8, 9
Attachments	Base metal at details attached by full-penetration groove welds subject to longitudinal and/or transverse loading when the detail embodies a transition radius $R$ with the weld termination ground smooth and for transverse loading, the weld soundness established by radiographic or ultrasonic inspection in accordance with 9.25.2 or 9.25.3 of AWS D1.1  Longitudinal loading $R > 24$ in. (610 mm) $24$ in. (610 mm) $> R > 6$ in. (152 mm) $6$ in. (152 mm) $> R > 2$ in. (51 mm) $2$ in. (51 mm) $> R$  Detail base metal for transverse loading: equal thickness and reinforcement removed $R > 24$ in. (610 mm) $24$ in. (610 mm) $> R > 6$ in. (152 mm) $6$ in. (152 mm) $> R > 2$ in. (51 mm) $2$ in. (51 mm) $> R$  Detail base metal for transverse loading: equal thickness and reinforcement not removed $R > 24$ in. (610 mm) $24$ in. (610 mm) $> R > 6$ in. (152 mm) $6$ in. (152 mm) $> R > 2$ in. (51 mm) $2$ in. (51 mm) $> R$	T or Rev.	B	14
		T or Rev.	C	14
		T or Rev.	D	14
		T or Rev.	E	14
		T or Rev.	B	14
		T or Rev.	C	14
		T or Rev.	D	14
		T or Rev.	E	14, 15
		T or Rev.	C	14
		T or Rev.	C	14
		T or Rev.	D	14
		T or Rev.	E	14, 15

(Continued)

TABLE A-K4.2  
Stress Category Classifications—Continued

General Condition	Situation	Kind of Stress <sup>a</sup>	Stress Category (see Table A-K4.3)	Illustrative Example Nos. (see Fig. A-K4.1) <sup>b</sup>	
Attachments (cont.)	Detail base metal for transverse loading: unequal thickness and reinforcement removed $R > 2$ in. (51 mm) $2$ in. (51 mm) $> R$	T or Rev. T or Rev.	D E	14 14,15	
	Detail base metal for transverse loading: unequal thickness and reinforcement not removed all $R$	T or Rev.	E	14, 15	
	Detail base metal for transverse loading $R > 6$ in. (152 mm) $6$ in. (152 mm) $> R > 2$ in. (51 mm) $2$ in. (51 mm) $> R$	T or Rev. T or Rev. T or Rev.	C D E	19 19 19	
	Base metal at detail attached by full-penetration groove welds subject to longitudinal loading $2 < a < 12b$ or 4 in. (102 mm) $a > 12b$ or 4 in. (102 mm) when $b \leq 1$ in. (25 mm) $a > 12b$ or 4 in. (102 mm) when $b > 1$ in. (25 mm)	T or Rev. T or Rev.	D E	15 15	
		T or Rev.	E'	15	
		Base metal at detail attached by fillet welds or partial-penetration groove welds subject to longitudinal loading $a < 2$ in. (51 mm) $2$ in. (51 mm) $< a < 12b$ or 4 in. (102 mm) $a > 12b$ or 4 in. (102 mm) when $b \leq 1$ in. (25 mm) $a > 12b$ or 4 in. (102 mm) when $b > 1$ in. (25 mm)	T or Rev. T or Rev. T or Rev.	C D E	15, 23, 24, 25, 26 15, 23, 24, 26 15, 23, 24, 26
	T or Rev.		E'	15, 23, 24, 26	
	Base metal attached by fillet welds or partial-penetration groove welds subjected to longitudinal loading when the weld termination embodies a transition radius with the weld termination ground smooth: $R > 2$ in. (51 mm) $R \leq 2$ in. (51 mm)		T or Rev. T or Rev.	D E	19 19
			Fillet-welded attachments where the weld termination embodies a transition radius, weld termination ground smooth, and main material subject to longitudinal loading: Detail base metal for transverse loading: $R > 2$ in. (51 mm) $R < 2$ in. (51 mm)	T or Rev. T or Rev.	D E
Base metal at stud-type shear connector attached by fillet weld or automatic end weld	T or Rev.	C		22	
Shear stress on nominal area of stud-type shear connectors	S	F			

<sup>a</sup>"T" signifies range in tensile stress only; "Rev." signifies a range involving reversal of tensile or compressive stress; "S" signifies range in shear, including shear stress reversal.  
<sup>b</sup>These examples are provided as guidelines and are not intended to exclude other reasonably similar situations.  
<sup>c</sup>Allowable fatigue stress range for transverse partial-penetration and transverse fillet welds is a function of the effective throat, depth of penetration and plate thickness. See Frank and Fisher (1979).

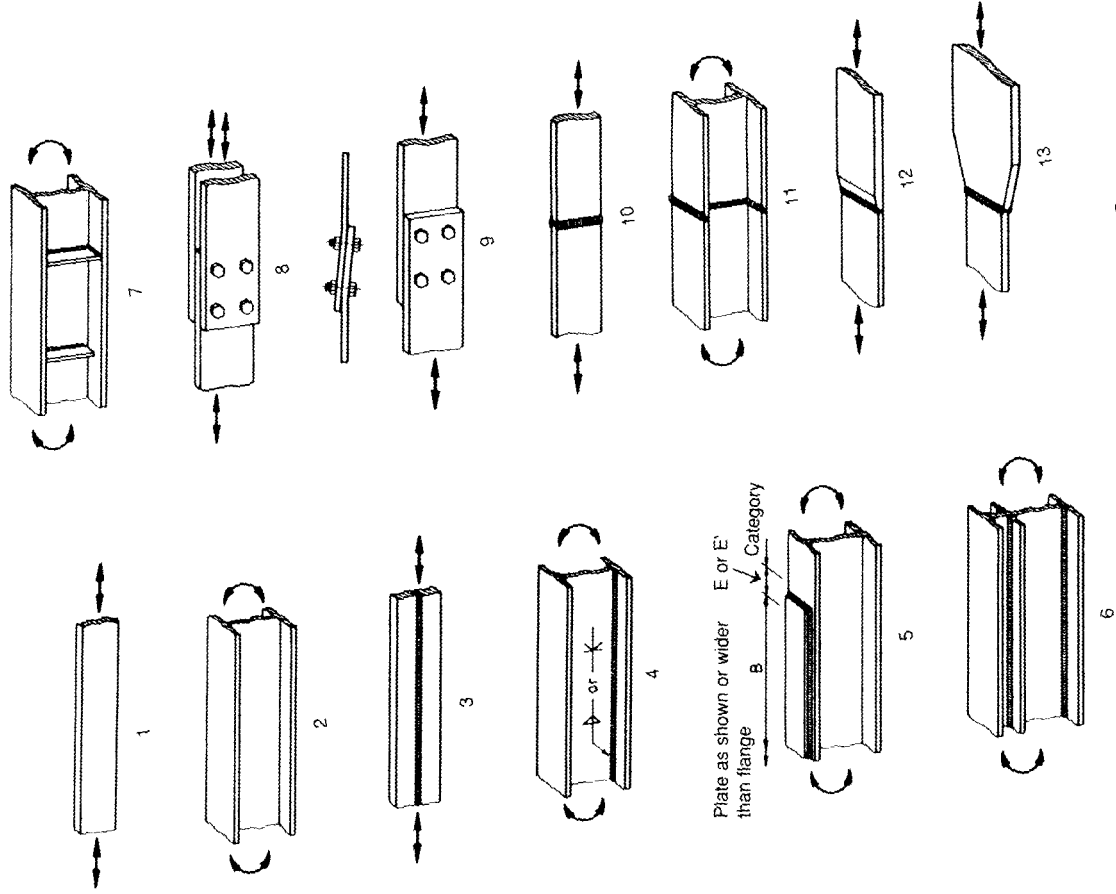

ILLUSTRATIVE EXAMPLES

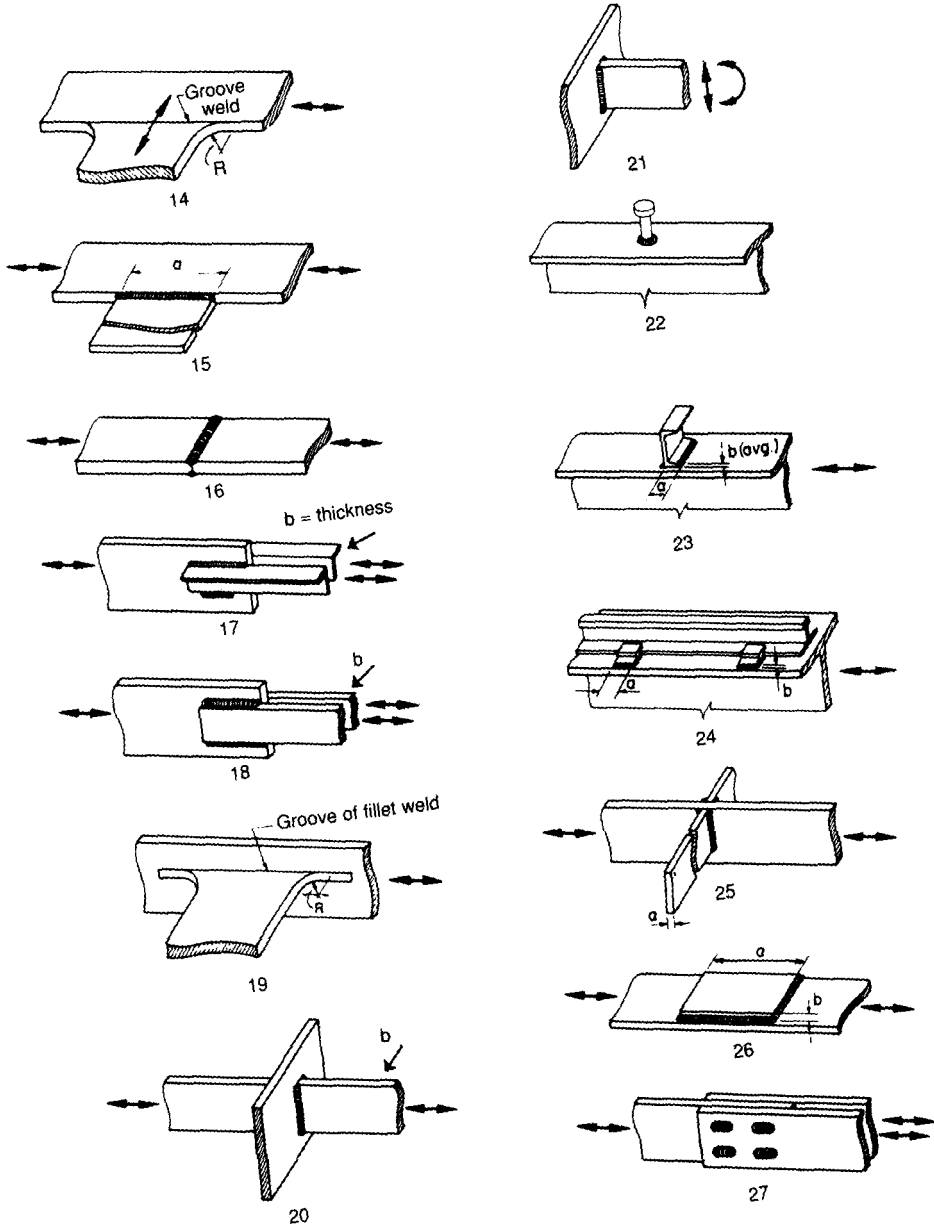

ILLUSTRATIVE EXAMPLES—(Continued)

2-726

Detail base metal for transverse loading: unequal thickness and reinforcement not removed all R	T or Rev.	E	14, 15
Detail base metal for transverse loading R > 6 in. (152 mm) 152 mm > R > 2 in. (51 mm)	T or Rev. T or Rev. T or Rev.	C D E	19 19 19

TABLE A-K4.3  
Allowable Stress Range, ksi

Category (From Table A-K4.2)	Loading Condition 1	Loading Condition 2	Loading Condition 3	Loading Condition 4
	× 6.89 for N/mm <sup>2</sup>			
A	63	37	24	24
8	49	29	18	16
B'	39	23	15	12
C	35	21	13	10 <sup>a</sup>
D	28	16	10	7
E	22	13	8	5
E'	16	9	6	3
F	15	12	9	8

<sup>a</sup>Flexural stress range of 12 ksi (83 N/mm<sup>2</sup>) permitted at toe of stiffener welds on flanges.

TABLE 1  
Allowable Stress as a Function of F<sub>y</sub>

F <sub>y</sub> (ksi)	Design Stress (ksi)					
	0.40F <sub>y</sub> <sup>b,e</sup>	0.45F <sub>y</sub> <sup>a</sup>	0.60F <sub>y</sub> <sup>a,c</sup>	0.66F <sub>y</sub> <sup>c</sup>	0.75F <sub>y</sub> <sup>c</sup>	0.90F <sub>y</sub> <sup>d</sup>
× 6.89 for N/mm <sup>2</sup>						
33	13.2	14.9	19.8	21.8	24.8	29.7
35	14.0	15.8	21.0	23.1	26.3	31.5
36	14.5	16.2	22.0	24.0	27.0	32.4
40	16.0	18.0	24.0	26.4	30.0	36.0
42	16.8	18.9	25.2	27.7	31.5	37.8
45	18.0	20.3	27.0	29.7	33.8	40.5
46	18.4	20.7	27.6	30.4	34.5	41.4
50	20.0	22.5	30.0	33.0	37.5	45.0
55	22.0	24.8	33.0	36.3	41.3	49.5
60	24.0	27.0	36.0	39.6	45.0	54.0
65	26.0	29.3	39.0	42.9	48.8	58.5
70	28.0	31.5	42.0			63.0
90	36.0	40.5	54.0			81.0
100	40.0	45.0	60.0			90.0

<sup>a</sup>See Sect. D1, D3 Tension  
<sup>b</sup>See Sect. D3, F4, K1 Shear  
<sup>c</sup>See Sect. F1, F2 Bending  
<sup>d</sup>See Sect. J8 Bearing  
<sup>e</sup>See Sect. G3 Shear in Plate Girders

TABLE 2  
Allowable Stresses as a Function of  $F_u$

Item	ASTM Designation	$F_y$ (ksi)	$F_u$ (ksi)	Allowable Stress (ksi)				
				Connected Part of Designated Steel		Bolt or Threaded Part of Designated Steel		
				Tension $0.5F_u^a$	Bearing $1.2F_u^b$	Tension $0.33F_u^c$	Shear $0.17F_u^d$	Shear $0.22F_u^e$
× 6.89 for N/mm <sup>2</sup>								
Shapes, Plates, Bars, Sheet and Tubing or Threaded Parts	A36	36	58-80	29.0	69.6	19.1	9.9	12.8
	A53	35	60	30.0	72.0	—	—	—
	[ A242 A441 A588 ]	50	70	35.0	84.0	23.1	11.9	15.4
		46	67	33.5	80.4	22.1	11.4	14.7
		42	63	31.5	75.6	20.8	10.7	13.9
		40 <sup>f</sup>	60	30.0	72.0	19.8	10.2	13.2
	A500	33/39 <sup>g</sup>	45	22.5	54.0	—	—	—
		42/46 <sup>g</sup>	58	29.0	69.6	—	—	—
		46/50 <sup>g</sup>	62	31.0	74.4	—	—	—
	A501	36	58	29.0	69.6	—	—	—
	A529	42	60-85	30.0	72.0	19.8	10.2	13.2
	A570	40	55	27.5	66.0	—	—	—
		42	58	29.0	69.6	—	—	—
	A572	42	60	30.0	72.0	19.8	10.2	13.2
		50	65	32.5	78.0	21.5	11.1	14.3
		60	75	37.5	90.0	24.8	12.8	16.5
		65	60	40.0	96.0	26.4	13.6	17.6
	A514	100	110-130	55.0	132	36.3	18.7	24.2
90		100-130	50.0	120	33.0	17.0	22.0	
A606	45	65	32.5	78.0	—	—	—	
	50	70	35.0	84.0	—	—	—	
A607	45	60	30.0	72.0	—	—	—	
	50	65	32.5	78.0	—	—	—	
	55	70	35.0	84.0	—	—	—	
	60	75	37.5	90.0	—	—	—	
	65	60	40.0	96.0	—	—	—	
	70	65	42.5	102	—	—	—	
A618	50	70	35.0	84.0	—	—	—	
	50	65	32.5	78.0	—	—	—	
A852	70	90-110	45.0	108	—	—	—	
Bolts	A449	92	120	—	—	39.6	20.4	26.4
		81	105	—	—	34.7	17.9	23.1
		58	90	—	—	29.7	15.3	19.8

<sup>a</sup>On effective net area, see Sects. D1, J4.  
<sup>b</sup>Produced by fastener in shear, see Sect. J3.7. Note that smaller maximum design bearing stresses, as a function of hole spacing, may be required by Sects. J3.8 and J3.9.  
<sup>c</sup>On nominal body area, see Table J3.2.  
<sup>d</sup>Threads not excluded from shear plane, see Table J3.2.  
<sup>e</sup>Threads excluded from shear plane, see Table J3.2.  
<sup>f</sup>For A441 material only.  
<sup>g</sup>Smaller value for circular shapes, larger for square or rectangular shapes.  
 Note: For dimensional and size limitations, see the appropriate ASTM Specification.

TABLE 3  
VALUES OF  $C_a$

For Determining Allowable Stress When  $Kl/r \leq C_c$  for Steel of Any Yield Stress  
(by Eq.  $F_a = C_a F_y$ )<sup>a</sup>

$\frac{Kl/r}{C_c}$	$C_a$	$\frac{Kl/r}{C_c}$	$C_a$	$\frac{Kl/r}{C_c}$	$C_a$	$\frac{Kl/r}{C_c}$	$C_a$
.01	.599	.26	.548	.51	.472	.76	.375
.02	.597	.27	.546	.52	.469	.77	.371
.03	.596	.28	.543	.53	.465	.78	.366
.04	.594	.29	.540	.54	.462	.79	.362
.05	.593	.30	.538	.55	.458	.80	.357
.06	.591	.31	.535	.56	.455	.81	.353
.07	.589	.32	.532	.57	.451	.82	.348
.08	.588	.33	.529	.58	.447	.83	.344
.09	.586	.34	.527	.59	.444	.84	.339
.10	.584	.35	.524	.60	.440	.85	.335
.11	.582	.36	.521	.61	.436	.86	.330
.12	.580	.37	.518	.62	.432	.87	.325
.13	.578	.38	.515	.63	.428	.88	.321
.14	.576	.39	.512	.64	.424	.89	.316
.15	.574	.40	.509	.65	.420	.90	.311
.16	.572	.41	.506	.66	.416	.91	.306
.17	.570	.42	.502	.67	.412	.92	.301
.18	.568	.43	.499	.68	.408	.93	.296
.19	.565	.44	.496	.69	.404	.94	.291
.20	.563	.45	.493	.70	.400	.95	.286
.21	.561	.46	.489	.71	.396	.96	.281
.22	.558	.47	.486	.72	.392	.97	.276
.23	.556	.48	.483	.73	.388	.98	.271
.24	.553	.49	.479	.74	.384	.99	.266
.25	.551	.50	.476	.75	.379	1.00	.261

All grades of steel

<sup>a</sup>When ratios exceed the noncompact section limits of Sect. B5.1, use  $\frac{Kl/r}{C_c}$  in lieu of  $\frac{Kl/r}{C_c}$  values and equation  $F_a = C_a Q_a Q_s F_y$  (Appendix Sect. B5).

TABLE 4  
VALUES OF  $C_c$

For Use with Equations (E2-1) and (E2-2) and in Table 3

$F_y$ (ksi) ( $\times 6.89$ for N/mm <sup>2</sup> )	$C_c$	$F_y$ (ksi) ( $\times 6.89$ for N/mm <sup>2</sup> )	$C_c$
33	131.7	46	111.6
35	127.9	50	107.0
36	126.1	55	102.0
39	121.2	60	97.7
40	119.6	65	93.8
42	116.7	90	79.8
45	112.8	100	75.7

TABLE 5  
Slenderness Ratios of Elements as a Function of  $F_y$

Specification Section and Ratios	$F_y$ (ksi)					
	36	42	46	50	60	65
Table B5.1						
$65/\sqrt{F_y}$	10.8	10.0	9.6	9.2	8.4	8.1
$190/\sqrt{F_y}$	31.7	29.3	28.0	26.9	24.5	23.6
$640/\sqrt{F_y}$	106.7	98.8	94.4	90.5	82.6	79.4
$257/\sqrt{F_y}$	42.8	39.7	37.9	36.3	33.2	31.9
Sect. F1.2						
$\sqrt{\frac{102 \times 10^3 C_b}{F_y}}$	$53\sqrt{C_b}$	$49\sqrt{C_b}$	$47\sqrt{C_b}$	$45\sqrt{C_b}$	$41\sqrt{C_b}$	$40\sqrt{C_b}$
$\sqrt{\frac{510 \times 10^3 C_b}{F_y}}$	$119\sqrt{C_b}$	$110\sqrt{C_b}$	$105\sqrt{C_b}$	$101\sqrt{C_b}$	$92\sqrt{C_b}$	$89\sqrt{C_b}$
Table B5.1						
$76/\sqrt{F_y}$	12.7	11.7	11.2	10.7	9.8	9.4
$95/\sqrt{F_y}$	15.8	14.7	14.0	13.4	12.3	11.8
$127/\sqrt{F_y}$	21.2	19.6	18.7	18.0	16.4	15.8
Table B5.1						
$238/\sqrt{F_y}$	39.7	36.7	35.1	33.7	30.7	29.5
$317/\sqrt{F_y}$	52.8	48.9	46.7	44.8	40.9	39.3
$253/\sqrt{F_y}$	42.2	39.0	37.3	35.8	32.7	31.4
Table B5.1—Appendix B5.2b						
$3300/F_y$	91.7	78.6	71.7	66.0	55.0	50.8
$13000/F_y$	361	310	283	260	217	200
Sect. G1						
$\frac{14000}{F_y (F_y + 16.5)}$	322	282	261	243	207	192
$2000/\sqrt{F_y}$	333	309	295	283	258	248

**NOTE:** See next page for metric conversions.

TABLE 5  
Slenderness Ratios of Elements as a Function of  $F_y$

Specification Section and Ratios	$F_y$ (ksi)					
	$\times 6.89$ for N/mm <sup>2</sup>					
	36	42	46	50	60	65
Table B5.1						
$0.38 \sqrt{E/F_y}$	10.8	10.0	9.6	9.2	8.4	8.1
$1.12 \sqrt{E/F_y}$	31.7	29.3	28.0	26.9	24.5	23.6
$3.76 \sqrt{E/F_y}$	106.7	98.8	94.4	90.5	82.6	79.4
$1.51 \sqrt{E/F_y}$	42.8	39.7	37.9	36.3	33.2	31.9
Sect. F1.2						
$\sqrt{\frac{3.52EC_b}{F_y}}$	$53 \sqrt{C_b}$	$49 \sqrt{C_b}$	$47 \sqrt{C_b}$	$45 \sqrt{C_b}$	$41 \sqrt{C_b}$	$40 \sqrt{C_b}$
$\sqrt{\frac{17.59EC_b}{F_y}}$	$119 \sqrt{C_b}$	$110 \sqrt{C_b}$	$105 \sqrt{C_b}$	$101 \sqrt{C_b}$	$92 \sqrt{C_b}$	$89 \sqrt{C_b}$
Table B5.1						
$0.45 \sqrt{E/F_y}$	12.7	11.7	11.2	10.7	9.8	9.4
$0.56 \sqrt{E/F_y}$	15.8	14.7	14.0	13.4	12.3	11.8
$0.75 \sqrt{E/F_y}$	21.2	19.6	18.7	18.0	16.4	15.8
Table B5.1						
$1.40 \sqrt{E/F_y}$	39.7	36.7	35.1	33.7	30.7	29.5
$1.86 \sqrt{E/F_y}$	52.8	48.9	46.7	44.8	40.9	39.3
$1.49 \sqrt{E/F_y}$	42.2	39.0	37.3	35.8	32.7	31.4
Table B5.1—Appendix B5.2b						
$0.11 E/F_y$	91.7	78.6	71.7	66.0	55.0	50.8
$0.43 E/F_y$	361	310	283	260	217	200
Sect. G1						
$\frac{0.48E}{F_y (F_y + 113.7)}$	322	282	261	243	207	192
$11.76 \sqrt{E/F_y}$	333	309	295	283	258	248

TABLE 6  
Values of  $C_b$   
For Use in Equations (F1-6), (F1-7) and (F1-8)

$\frac{M_1}{M_2}$	$C_b$	$\frac{M_1}{M_2}$	$C_b$	$\frac{M_1}{M_2}$	$C_b$
-1.00	1.00	-0.45	1.34	0.10	1.86
-0.95	1.02	-0.40	1.38	0.15	1.91
-0.90	1.05	-0.35	1.42	0.20	1.97
-0.85	1.07	-0.30	1.46	0.25	2.03
-0.80	1.10	-0.25	1.51	0.30	2.09
-0.75	1.13	-0.20	1.55	0.35	2.15
-0.70	1.16	-0.15	1.60	0.40	2.22
-0.65	1.19	-0.10	1.65	0.45	2.28
-0.60	1.23	-0.05	1.70	$\geq 0.47$	2.30
-0.55	1.26	0	1.75		
-0.50	1.30	0.05	1.80		

Note 1:  $C_b = 1.75 + 1.05(M_1/M_2) + 0.3(M_1/M_2)^2 \leq 2.3$   
 Note 2:  $M_1/M_2$  positive for reverse curvature and negative for single curvature.

TABLE 7  
Values of  $C_m$   
For Use in Equation (H1-1)

$\frac{M_1}{M_2}$	$C_b$	$\frac{M_1}{M_2}$	$C_b$	$\frac{M_1}{M_2}$	$C_b$
-1.00	1.00	-0.45	0.78	0.10	0.56
-0.95	0.98	-0.40	0.76	0.15	0.54
-0.90	0.96	-0.35	0.74	0.20	0.52
-0.85	0.94	-0.30	0.72	0.25	0.50
-0.80	0.92	-0.25	0.70	0.30	0.48
-0.75	0.90	-0.20	0.68	0.35	0.46
-0.70	0.88	-0.15	0.66	0.40	0.44
-0.65	0.86	-0.10	0.64	0.45	0.42
-0.60	0.84	-0.05	0.62	0.50	0.40
				0.60	0.36
-0.55	0.82	0	0.60	0.80	0.28
-0.50	0.80	0.05	0.58	1.00	0.20

Note 1:  $C_m = 0.6 - 0.4(M_1/M_2)$ .  
 Note 2:  $M_1/M_2$  is positive for reverse curvature and negative for single curvature.

TABLE 8  
Values of  $F'_e$   
For Use in Equation (H1-1), for Steel of Any Yield Stress

	$\frac{K'l_b}{r_b}$	$F'_e$ (ksi)	$\frac{K'l_b}{r_b}$	$F'_e$ (ksi)	$\frac{K'l_b}{r_b}$	$F'_e$ (ksi)	$\frac{K'l_b}{r_b}$	$F'_e$ (ksi)	$\frac{K'l_b}{r_b}$	$F'_e$ (ksi)
	× 6.89 for N/mm <sup>2</sup>									
All grades of steel	21	338.62	51	57.41	81	22.76	111	12.12	141	7.51
	22	308.54	52	55.23	82	22.21	112	11.90	142	7.41
	23	282.29	53	53.16	83	21.68	113	11.69	143	7.30
	24	259.26	54	51.21	84	21.16	114	11.49	144	7.20
	25	238.93	55	49.37	85	20.67	115	11.29	145	7.10
	26	220.90	56	47.62	86	20.19	116	11.10	146	7.01
	27	204.84	57	45.96	87	19.73	117	10.91	147	6.91
	28	190.47	58	44.39	88	19.28	118	10.72	148	6.82
	29	177.56	59	42.90	89	18.85	119	10.55	149	6.73
	30	165.92	60	41.48	90	18.44	120	10.37	150	6.64
	31	155.39	61	40.13	91	18.03	121	10.20	151	6.55
	32	145.83	62	38.85	92	17.64	122	10.03	152	6.46
	33	137.13	63	37.62	93	17.27	123	9.87	153	6.38
	34	129.18	64	36.46	94	16.90	124	9.71	154	6.30
	35	121.90	65	35.34	95	16.55	125	9.56	155	6.22
	36	115.22	66	34.28	96	16.20	126	9.41	156	6.14
	37	109.08	67	33.27	97	15.87	127	9.26	157	6.06
	38	103.42	68	32.29	98	15.55	128	9.11	158	5.98
	39	98.18	69	31.37	99	15.24	129	8.97	159	5.91
	40	93.33	70	30.48	100	14.93	130	8.84	160	5.83
	41	88.83	71	29.62	101	14.64	131	8.70	161	5.76
	42	84.65	72	28.21	102	14.35	132	8.57	162	5.69
	43	80.76	73	28.02	103	14.08	133	8.44	163	5.62
	44	77.13	74	27.27	104	13.81	134	8.32	164	5.55
	45	73.74	75	26.55	105	13.54	135	8.19	165	5.49
	46	70.57	76	25.85	106	13.29	136	8.07	166	5.42
	47	67.60	77	25.19	107	13.04	137	7.96	167	5.35
	48	64.81	78	24.54	108	12.80	138	7.84	168	5.29
	49	62.20	79	23.93	109	12.57	139	7.73	169	5.23
	50	59.73	80	23.33	110	12.34	140	7.62	170	5.17

Note:  $F'_e = \frac{12\pi^2 E}{23(K'l_b/r_b)^2}$

## SYMBOLS

The section numbers in parentheses after the definition of a symbol refers to the section where the symbol is first used.

- $A$  Gross area of an axially loaded compression member, in.<sup>2</sup> (mm<sup>2</sup>) (N4)
- $A_b$  Nominal body area of a fastener, in.<sup>2</sup> (mm<sup>2</sup>) (J3.5); area of an upset rod based upon the major diameter of its threads, i.e., the diameter of a coaxial cylinder which would bound the crests of the threads, in.<sup>2</sup> (mm<sup>2</sup>) (J3.4)
- $A_c$  Actual area of effective concrete flange in composite design, in.<sup>2</sup> (mm<sup>2</sup>) (I4)
- $A_e$  Effective net area of an axially loaded tension member, in.<sup>2</sup> (mm<sup>2</sup>) (B3)
- $A_f$  Area of compression flange, in.<sup>2</sup> (mm<sup>2</sup>) (F1.1)
- $A_{fe}$  Effective tension flange area, in.<sup>2</sup> (mm<sup>2</sup>) (B10)
- $A_{fg}$  Gross beam flange area, in.<sup>2</sup> (mm<sup>2</sup>) (B10)
- $A_{fn}$  Net beam flange area, in.<sup>2</sup> (mm<sup>2</sup>) (B10)
- $A_g$  Gross area of member, in.<sup>2</sup> (mm<sup>2</sup>) (B3)
- $A_n$  Net area of an axially loaded tension member, in.<sup>2</sup> (mm<sup>2</sup>) (B2)
- $A_s$  Area of steel beam in composite design, in.<sup>2</sup> (mm<sup>2</sup>) (I4)
- $A's$  Area of compressive reinforcing steel, in.<sup>2</sup> (mm<sup>2</sup>) (I4)
- $A_{sr}$  Area of reinforcing steel providing composite action at point of negative moment, in.<sup>2</sup> (mm<sup>2</sup>) (I4)
- $A_{st}$  Cross-sectional area of stiffener or pair of stiffeners, in.<sup>2</sup> (mm<sup>2</sup>) (G4)
- $A_t$  Net tension area, in.<sup>2</sup> (mm<sup>2</sup>) (J4)
- $A_v$  Net shear area, in.<sup>2</sup> (mm<sup>2</sup>) (J4)
- $A_w$  Area of girder web, in.<sup>2</sup> (mm<sup>2</sup>) (G2)
- $A_1$  Area of steel concentrically bearing on a concrete support, in.<sup>2</sup> (mm<sup>2</sup>) (J9)
- $A_2$  Maximum area of the portion of the supporting surface that is geometrically similar to and concentric with the loaded area, in.<sup>2</sup> (mm<sup>2</sup>) (J9)
- $B$  Bending coefficient dependent upon computed moment or stress at the ends of unbraced segments of a tapered member (Appendix F7.4)
- $C_a$  Coefficient used in Table 4 of Numerical Values
- $C_b$  Bending coefficient dependent upon moment gradient (F1. 3)
- $C_c$  Column slenderness ratio separating elastic and inelastic buckling (E2)
- $C'_c$  Slenderness ratio of compression elements (Appendix B5.2)
- $C_h$  Coefficient used in Table 12 of Numerical Values
- $C_m$  Coefficient applied to bending term in interaction equation for prismatic members and dependent upon column curvature caused by applied moments (H1)
- $C'm$  Coefficient applied to bending term in interaction equation for tapered members and dependent upon axial stress at the small end of the member (Appendix F7.6)

- $C_p$  Stiffness factor for primary member in a flat roof (K2)
- $C_s$  Stiffness factor for secondary member in a flat roof (K2)
- $C_v$  Ratio of "critical" web stress, according to the linear buckling theory, to the shear yield stress of web material (F4)
- $C_1$  Increment used in computing minimum spacing of oversized and slotted holes (J3.8)
- $C_2$  Increment used in computing minimum edge distance for oversized and slotted holes (J3.9)
- $D$  Factor depending upon type of transverse stiffeners (G4); outside diameter of tubular member, in. (Appendix B5.2)
- $E$  Modulus of elasticity of steel [29,000 ksi (199 810 N/mm<sup>2</sup>)] (E2)
- $E_c$  Modulus of elasticity of concrete, ksi (N/mm<sup>2</sup>) (I2)
- $F_a$  Axial compressive stress permitted in a prismatic member in the absence of bending moment, ksi (N/mm<sup>2</sup>) (E2)
- $F_a\gamma$  Axial compressive stress permitted in a tapered member in the absence of bending moment, ksi (N/mm<sup>2</sup>) (Appendix F7.3)
- $F_b$  Bending stress permitted in a prismatic member in the absence of axial force, ksi (N/mm<sup>2</sup>) (F1.1)
- $F'_b$  Allowable bending stress in compression flange of plate girders as reduced for hybrid girders or because of large web depth-to-thickness ratio, ksi (N/mm<sup>2</sup>) (G2)
- $F_{a\gamma}$  Bending stress permitted in a tapered member in the absence of axial force, ksi (N/mm<sup>2</sup>) (Appendix F7.6)
- $F'_e$  Euler stress for a prismatic member divided by factor of safety, ksi (N/mm<sup>2</sup>) (H1)
- $F'_e\gamma$  Euler stress for a tapered member divided by factor of safety, ksi (N/mm<sup>2</sup>) (Appendix F7.6)
- $F_p$  Allowable bearing stress, ksi (N/mm<sup>2</sup>) (J3.7)
- $F_{s\gamma}$  St. Venant torsion resistance bending stress in a tapered member, ksi (N/mm<sup>2</sup>) (Appendix F7.4)
- $F_t$  Allowable axial tensile stress, ksi (N/mm<sup>2</sup>) (D1)
- $F_u$  Specified minimum tensile strength of the type of steel or fastener being used, ksi (N/mm<sup>2</sup>) (B10)
- $F_v$  Allowable shear stress, ksi (N/mm<sup>2</sup>) (F4)
- $F_{w\gamma}$  Flange warping torsion resistance bending stress in a tapered member, ksi (N/mm<sup>2</sup>) (Appendix F7.4)
- $F_y$  Specified minimum yield stress of the type of steel being used, ksi (N/mm<sup>2</sup>) (B5.1). As used in this Specification, "yield stress" denotes either the specified minimum yield point (for those steels with a yield point) or specified minimum yield strength (for those steels without a yield point)
- $F_{yc}$  Specified minimum column yield stress, ksi (N/mm<sup>2</sup>) (K1.2)
- $F_{yf}$  Specified minimum yield stress of flange, ksi (N/mm<sup>2</sup>) (Table B5.1)
- $F_{yr}$  Specified minimum yield stress of the longitudinal reinforcing steel, ksi (N/mm<sup>2</sup>) (I4)
- $F_{yst}$  Specified minimum stiffener yield stress, ksi (N/mm<sup>2</sup>) (K1.8)

- $F_{yw}$  Specified minimum yield stress of beam web, ksi ( $N/mm^2$ ) (B5.1)
- $H_s$  Length of a stud shear connector after welding, in. (mm) (I5.2)
- $I_d$  Moment of inertia of steel deck supported on secondary members, in.<sup>4</sup> (mm<sup>4</sup>) (K2)
- $I_{eff}$  Effective moment of inertia of composite sections for direction computations, in.<sup>4</sup> (mm<sup>4</sup>) (I4)
- $I_p$  Moment of inertia of primary member in flat roof framing, in.<sup>4</sup> (mm<sup>4</sup>) (K2)
- $I_s$  Moment of inertia of secondary member in flat roof framing, in.<sup>4</sup> (mm<sup>4</sup>) (K2); moment of inertia of steel beam in composite construction, in.<sup>4</sup> (mm<sup>4</sup>) (I4)
- $I_{tr}$  Moment of inertia of transformed composite section, in.<sup>4</sup> (mm<sup>4</sup>) (I4)
- $K$  Effective length factor for a prismatic member (B7)
- $K_\gamma$  Effective length factor for a tapered member (Appendix F7.3)
- $L$  Unbraced length of tensile members, in. (B7); actual unbraced length of a column, in. (C2); unbraced length of member measured between the centers of gravity of the bracing members, in. (mm) (Appendix F7.1)
- $L_c$  Maximum unbraced length of the compression flange at which the allowable bending stress may be taken at  $0.66 F_y$  or as determined by Specification Equation (F1-3) or Equation (F2-3), when applicable, ft. (mm) (F1)
- $L_e$  Distance from free edge to center of the bolt, in. (mm) (J3.6)
- $L_p$  Length of primary member in flat roof framing, ft. (mm) (K2)
- $L_s$  Length of secondary member in flat roof framing, ft. (mm) (K2)
- $M$  Moment, kip-ft. ( $N\cdot mm$ ) (I4); maximum factored bending moment, kip-ft. ( $N\cdot mm$ ) (N4)
- $M_1$  Smaller moment at end of unbraced length of beam-column (F3.1); larger moment at one end of three-segment portion of a tapered member (Appendix F7.4)
- $M_2$  Larger moment at end of unbraced length of beam-column (F3.1); maximum moment in three adjacent segments of a tapered member (Appendix F7.4)
- $M_m$  Critical moment that can be resisted by a plastically designed member in the absence of axial load, kip-ft. ( $N\cdot mm$ ) (N4)
- $M_p$  Plastic moment, kip-ft. ( $N\cdot mm$ ) (N4)
- $N$  Length of bearing of applied load, in. (mm) (K1.3)
- $N_r$  Number of stud shear connectors on a beam in one transverse rib of a metal deck, not to exceed 3 in calculations (I5.2)
- $N_1$  Number of shear connectors required between point of maximum moment and point of zero moment (I4)
- $N_2$  Number of shear connectors required between concentrated load and point of zero moment (I4)
- $P$  Force transmitted by a fastener, kips (N) (J3.8); factored axial load, kips (N3); normal force, kips (N) (J10.2); axial load, kips (N) (C1)
- $P_{bf}$  Factored beam flange or connection plate force in a restrained connection, kips (N) (K1.2)
- $P_{cr}$  Maximum strength of an axially loaded compression member or beam, kips (N) (N3.1)

$P_e$	Euler buckling load, kips (N) (N4)
$P_y$	Plastic axial load, equal to profile area times specified minimum yield stress, kips (N) (N3.1)
$Q$	Full reduction factor for slender compression elements (Appendix B5.2)
$Q_a$	Ratio of effective profile area of an axially loaded member to its total profile area (Appendix B5.2)
$Q_s$	Axial stress reduction factor where width-thickness ratio of unstiffened elements exceeds noncompact section limits given in Section B5 (Appendix B5.2)
$R$	Reaction or concentrated load applied to beam or girder, kips (N) (K1.3); radius, in. (mm) (J2.1)
$R_{PG}$	Plate girder bending strength reduction factor (G2)
$R_e$	Hybrid girder factor (G2)
$S$	Spacing of secondary members in a flat roof, ft (H2); governing slenderness ratio of a tapered member (Appendix F7.3)
$S_{eff}$	Effective section modulus corresponding to partial composite action, in. <sup>3</sup> (mm <sup>3</sup> ) (I2)
$S_s$	Section modulus of steel beam used in composite design, referred to the bottom flange, in. <sup>3</sup> (mm <sup>3</sup> ) (I2)
$S_{tr}$	Section modulus of transformed composite cross section, referred to the bottom flange; based upon maximum permitted effective width of concrete flange, in. <sup>3</sup> (mm <sup>3</sup> ) (I2)
$T_b$	Specified pretension of a high-strength bolt, kips (N) (J3.6)
$U$	Reduction coefficient used in calculating effective net area (B3)
$V$	Shear produced by factored loading, kips (N) (N5); friction force, kips (N) (J10.2)
$V_h$	Total horizontal shear to be resisted by connectors under full composite action, kips (N) (I2)
$V'_h$	Total horizontal shear provided by the connectors providing partial composite action, kips (N) (I2)
$Y$	Ratio of yield stress of web steel to yield stress of stiffener steel (G4)
$Z$	Plastic section modulus, in. <sup>3</sup> (mm <sup>3</sup> ) (N4)
$a$	Clear distance between transverse stiffeners, in. (mm) (F4); dimension parallel to the direction of stress, in. (mm) (Appendix K4)
$a'$	Distance beyond theoretical cut-off point required at ends of welded partial length cover plate to develop stress, in. (mm) (B10)
$b$	Actual width of stiffened and unstiffened compression elements as defined in Section B5.1, in. (mm); dimension normal to the direction of stress, in. (mm) (Appendix K4)
$b_e$	Effective width of stiffened compression element, in. (mm) (Appendix B5.2)
$b_f$	Flange width of rolled beam or plate girder, in. (mm) (F1.1)
$d$	Depth of beam or girder, in. (mm) (B5.1); diameter of a roller or rocker bearing, in. (mm) (J8); nominal diameter of a fastener, in. (mm) (J3.7)
$d_L$	Depth at the larger end of a tapered member, in. (mm) (Appendix F7.1)
$d_c$	Web depth clear of fillets, in. (mm) (K1.5)

- $d_o$  Depth at the smaller end of a tapered member or unbraced segment thereof, in. (mm) (Appendix F7.1)
- $f$  Axial compression stress on member based on effective area, ksi (N/mm<sup>2</sup>) (Appendix B5.2)
- $f_a$  Computed axial stress, ksi (N/mm<sup>2</sup>) (B5.1)
- $f_{a0}$  Computed axial stress at the smaller end of a tapered member or unbraced segment thereof, ksi (N/mm<sup>2</sup>) (Appendix F7.6)
- $f_b$  Computed bending stress, ksi (N/mm<sup>2</sup>) (H1)
- $f_{b1}$  Smallest computed bending stress at one end of a tapered segment, ksi (N/mm<sup>2</sup>) (Appendix F7.4)
- $f_{b2}$  Largest computed bending stress at one end of a tapered segment, ksi (N/mm<sup>2</sup>) (Appendix F7.4)
- $f_{bl}$  Computed bending stress at the larger end of a tapered member or unbraced segment thereof, ksi (N/mm<sup>2</sup>) (Appendix F7.6)
- $f'_c$  Specified compression strength of concrete, ksi (N/mm<sup>2</sup>) (I2)
- $f_t$  Computed tensile stress, ksi (N/mm<sup>2</sup>) (J3.6)
- $f_v$  Computed shear stress, ksi (N/mm<sup>2</sup>) (F5)
- $f_{vs}$  Shear between girder web and transverse stiffeners, kips per linear in. (N/mm) of single stiffener or pair of stiffeners (G4)
- $g$  Transverse spacing between fastener gage lines, in. (mm) (B2)
- $h$  Clear distance between flanges of a beam or girder at the section under investigation, in. (mm) (B5)
- $h_r$  Nominal rib height for steel deck, in. (mm) (I5.2)
- $h_s$  Factor applied to the unbraced length of a tapered member (Appendix F7.4)
- $h_w$  Factor applied to the unbraced length of a tapered member (Appendix F7.4)
- $k$  Distance from outer face of flange to web toe of fillet of rolled shape or equivalent distance on welded section, in. (mm) (K1.3)
- $k_c$  Compression element restraint coefficient (B5)
- $k_v$  Shear buckling coefficient for girder webs (F4)
- $l$  For beams, distance between cross sections braced against twist or lateral displacement of the compression flange, in. (mm) (F1.3); for columns, actual unbraced length of member, in. (mm) (B7); unsupported length of a lacing bar, in. (mm) (E4); weld length, in. (mm) (B3); largest laterally unbraced length along either flange at the point of load, in. (mm) (K1.5)
- $l_b$  Actual unbraced length in plane of bending, in. (mm) (H1)
- $l_{cr}$  Critical unbraced length adjacent to plastic hinge, in. (mm) (N9)
- $n$  Modular ratio ( $E/E_c$ ) (I2)
- $q$  Allowable horizontal shear to be resisted by a shear connector, kips (N) (I4)
- $r$  Governing radius of gyration, in. (mm) (B7)
- $r_T$  Radius of gyration of a section comprising the compression flange plus one third of the compression web area, taken about an axis in the plane of the web, in. (mm) (F1.3)

- $r_{T_o}$  Radius of gyration at the smaller end of a tapered member or unbraced segment thereof, considering only the compression flange plus one third of the compression web area, taken about an axis in the plane of the web, in. (mm) (Appendix F7.4)
- $r_b$  Radius of gyration about axis of concurrent bending, in. (mm) (H1)
- $r_{b_o}$  Radius of gyration about axis of concurrent bending at the smaller end of a tapered member or unbraced segment thereof, in. (mm) (Appendix F7.6)
- $r_o$  Radius of gyration at the smaller end of a tapered member, in. (mm) (Appendix F7.3)
- $s$  Longitudinal center-to-center spacing (pitch) of any two consecutive holes, in. (mm) (B2)
- $t$  Thickness of a connected part, in. (mm) (I3.9); wall thickness of a tubular member, in. (mm) (Appendix B5); compression element thickness, in. (mm) (B5.1); filler thickness, in. (mm) (J6)
- $t_b$  Thickness of beam flange or moment connection plate at rigid beam-to-column connection, in. (mm) (K1.8)
- $t_f$  Flange thickness, in. (mm) (F1.1)
- $t_w$  Web thickness, in. (mm) (B5.1)
- $t_{wc}$  Column web thickness, in. (mm) (K1.6)
- $w$  Length of channel shear connectors, in. (mm) (I4); plate width (distance between welds), in. (mm) (B3)
- $w_r$  Average width of rib or haunch of concrete slab on formed steel deck, in. (mm) (I5.1)
- $x$  Subscript relating symbol to strong axis bending
- $y$  Subscript relating symbol to weak axis bending
- $z$  Distance from the smaller end of a tapered member, in. (mm) (Appendix F7.3)
- $\alpha$   $= 0.6 F_{yw}/F_b < 1.0$  (G2)
- $\beta$  Ratio  $S_{tr}/S_s$  or  $S_{eff}/S_s$  (I4)
- $\gamma$  Tapering ratio of a tapered member or unbraced segment of a tapered member (Appendix F7.1); subscript relating symbol to tapered members
- $\Delta$  Displacement of the neutral axis of a loaded member from its position when the member is not loaded, in. (mm) (C1)
- $\mu$  Coefficient of friction (J10.2)

**Division X—DESIGN STANDARD FOR LOAD AND RESISTANCE FACTOR DESIGN  
SPECIFICATION FOR COLD-FORMED STEEL STRUCTURAL MEMBERS**

**March 16, 1991, Edition  
Cold-Formed Steel Design Manual—Part I**

**American Iron and Steel Institute  
1133 15th Street, NW  
Washington, DC 20005-2701**

**SECTION 2252 — ADOPTION**

This publication is for general information only. The information in it should not be used without first securing competent advice with respect to its suitability for any given application. The publication of the information is not intended as a representation or warranty on the part of American Iron and Steel Institute—or any other person named herein—that the information is suitable for any general or particular use or of freedom from infringement of any patent or patents. Anyone making use of the information assumes all liability arising from such use.

1st Printing—August, 1991

Produced by Computerized Structural Design, Inc.  
Milwaukee, Wisconsin

Copyright American Iron and Steel Institute 1991

**TABLE OF CONTENTS  
LOAD AND RESISTANCE FACTOR DESIGN SPECIFICATION FOR  
COLD-FORMED STEEL STRUCTURAL MEMBERS  
MARCH 16, 1991 EDITION**

**SYMBOLS AND DEFINITIONS**

**A. GENERAL PROVISIONS**

- A1 Limits of Applicability and Terms
  - A1.1 Scope and Limits of Applicability
  - A1.2 Terms
  - A1.3 Units of Symbols and Terms
- A2 Non-Conforming Shapes and Constructions
- A3 Material
  - A3.1 Applicable Steels
  - A3.2 Other Steels
  - A3.3 Ductility
  - A3.4 Delivered Minimum Thickness
- A4 Loads
  - A4.1 Dead Load
  - A4.2 Live or Snow Load
  - A4.3 Impact Load
  - A4.4 Wind or Earthquake Loads
  - A4.5 Ponding
- A5 Structural Analysis and Design
  - A5.1 Design Basis
    - A5.1.1 Limit State—Strength
    - A5.1.2 Limit State—Serviceability
    - A5.1.3 Nominal Loads

- A5.1.4 Load Factors and Load Combinations
    - A5.1.5 Resistance Factors
  - A5.2 Yield Point and Strength Increase from Cold Work of Forming
    - A5.2.1 Yield Point
    - A5.2.2 Strength Increase from Cold Work of Forming
  - A5.3 Durability
- A6 Reference Documents
- B. ELEMENTS**
  - B1 Dimensional Limits and Considerations
    - B1.1 Flange Flat-Width-to-Thickness Considerations
    - B1.2 Maximum Web Depth-to-Thickness Ratio
  - B2 Effective Widths of Stiffened Elements
    - B2.1 Uniformly Compressed Stiffened Elements
    - B2.2 Uniformly Compressed Stiffened Elements with Circular Holes
    - B2.3 Effective Widths of Webs and Stiffened Elements with Stress Gradient
  - B3 Effective Widths of Unstiffened Elements
    - B3.1 Uniformly Compressed Unstiffened Elements
    - B3.2 Unstiffened Elements and Edge Stiffeners with Stress Gradient
  - B4 Effective Widths of Elements with an Edge Stiffener or One Intermediate Stiffener
    - B4.1 Uniformly Compressed Elements with an Intermediate Stiffener
    - B4.2 Uniformly Compressed Elements with an Edge Stiffener
  - B5 Effective Widths of Edge Stiffened Elements with Intermediate Stiffeners or Stiffened Elements with More Than One Intermediate Stiffener
  - B6 Stiffeners
    - B6.1 Transverse Stiffeners
    - B6.2 Shear Stiffeners
    - B6.3 Non-Conforming Stiffeners
- C. MEMBERS**
  - C1 Properties of Sections
  - C2 Tension Members
  - C3 Flexural Members
    - C3.1 Strength for Bending Only
      - C3.1.1 Nominal Section Strength
      - C3.1.2 Lateral Buckling Strength
      - C3.1.3 Beams Having One Flange Through-Fastened to Deck or Sheathing
    - C3.2 Strength for Shear Only
    - C3.3 Strength for Combined Bending and Shear
    - C3.4 Web Crippling Strength
    - C3.5 Combined Bending and Web Crippling Strength
  - C4 Concentrically Loaded Compression Members
    - C4.1 Sections Not Subject to Torsional or Torsional-Flexural Buckling
    - C4.2 Doubly- or Singly-Symmetric Sections Subject to Torsional or Torsional-Flexural Buckling
    - C4.3 Nonsymmetric Sections
  - C5 Combined Axial Load and Bending
  - C6 Cylindrical Tubular Members
    - C6.1 Bending
    - C6.2 Compression
    - C6.3 Combined Bending and Compression
- D. STRUCTURAL ASSEMBLIES**
  - D1 Built-Up Sections
    - D1.1 I—Sections Composed of Two Channels
    - D1.2 Spacing of Connections in Compression Elements

- D2 Mixed Systems
- D3 Lateral Bracing
  - D3.1 Symmetrical Beams and Columns
  - D3.2 Channel-Section and Z-Section Beams
    - D3.2.1 Anchorage of Bracing for Roof Systems Under Gravity Load With Top Flange Connected to Sheathing
    - D3.2.2 Neither Flange Connected to Sheathing
  - D3.3 Laterally Unbraced Box Beams
- D4 Wall Studs and Wall Stud Assemblies
  - D4.1 Wall Studs in Compression
  - D4.2 Wall Studs in Bending
  - D4.3 Wall Studs with Combined Axial Load and Bending

**E. CONNECTIONS AND JOINTS**

- E1 General Provisions
- E2 Welded Connections
  - E2.1 Groove Welds in Butt Joints
  - E2.2 Arc Spot Welds
  - E2.3 Arc Seam Welds
  - E2.4 Fillet Welds
  - E2.5 Flare Groove Welds
  - E2.6 Resistance Welds
- E3 Bolted Connections
  - E3.1 Spacing and Edge Distance
  - E3.2 Tension in Connected Part
  - E3.3 Bearing
  - E3.4 Shear and Tension in Bolts
- E4 Shear Rupture
- E5 Connections to Other Materials
  - E5.1 Bearing
  - E5.2 Tension
  - E5.3 Shear

**F. TESTS FOR SPECIAL CASES**

- F1 Tests for Determining Structural Performance
- F2 Tests for Confirming Structural Performance
- F3 Tests for Determining Mechanical Properties
  - F3.1 Full Section
  - F3.2 Flat Elements of Formed Sections
  - F3.3 Virgin Steel

**SYMBOLS AND DEFINITIONS**

Symbol	Definition	Section
A	Full unreduced cross-sectional area of the member	C3.1.1, C3.1.2, C4, C6.2, D4.1
$A_b$	$b_1t + A_s$ , for transverse stiffeners at interior support and under concentrated load, and $b_2t + A_s$ , for transverse stiffeners at end support	B6.1
$A_b$	Gross cross-sectional area of bolt	E3.4
$A_c$	$18t^2 + A_s$ , for transverse stiffeners at interior support and under concentrated load, and $10t^2 + A_s$ , for transverse stiffeners at end support	B6.1
$A_e$	Effective area at the stress $F_n$	C4, C6.2, D4.1
$A_n$	Net area of cross section	C2, E3.2

$A_s$	Cross-sectional area of transverse stiffeners	B4, B4.1, B4.2, B6.1
$A'_s$	Effective area of stiffener	B4, B4.1, B4.2
$A_{st}$	Gross area of shear stiffener	B6.2
$A_{wn}$	Net web area	E4
$A_1$	Bearing area	E5.1
$A_2$	Full cross sectional area of concrete support	E5.1
$a$	Shear panel length of the unreinforced web element. For a reinforced web element, the distance between transverse stiffeners	B6.2, C3.2
$a$	Length of bracing interval	D3.2
$B$	Stud spacing	D4, D4.1
$B_c$	Term for determining the tensile yield point of corners	A5.2.2
$b$	Effective design width of compression element	B2.1, B2.2, B2.3, B3.1, B3.2, B4.1, B4.2, B5
$b$	Flange width, Z-section	D3.2.1
$b_d$	Effective width for deflection calculation	B2.1, B2.2
$b_e$	Effective design width of sub-element or element	A1.2, B2.3, B5
$b_o$	See Figure B4.1	B4, B4.1, B5
$C$	For flexural members, ratio of the total corner cross-sectional area of the controlling flange to the full cross-sectional area of the controlling flange	A5.2.2
$C_b$	Bending coefficient dependent on moment gradient	C3.1.2
$C_m$	End moment coefficient in interaction formula	C5
$C_{ms}$	Coefficient for lateral bracing of Z-section	D3.2.1
$C_{mx}$	End moment coefficient in interaction formula	C5
$C_{my}$	End moment coefficient in interaction formula	C5
$C_p$	Correction Factor	F1
$C_s$	Coefficient for lateral torsional buckling	C3.1.2
$C_{TF}$	End moment coefficient in interaction formula	C3.1.2
$C_{th}$	Coefficient for lateral bracing of Z-sections	D3.2.1
$C_{tr}$	Coefficient for lateral bracing of Z-sections	D3.2.1
$C_v$	Shear stiffener coefficient	B6.2
$C_w$	Torsional warping constant of the cross-section	C3.1.2
$C_y$	Compression strain factor	C3.1.1
$C_o$	Initial column imperfection	D4.1
$C_1$	Term used to compute shear strain in wall board	B4, B4.1, D4.2
$C_2$	Coefficient as defined in Figure B4-2	B4, B4.2
$c_f$	Amount of curling	B1.1b
$D$	Outside diameter of cylindrical tube	C6, C6.1, C6.2, D4.2
$D$	Overall depth of lip	B1.1, B4, D1.1
$D$	Shear stiffener coefficient	B6.2
$D$	Nominal dead load	A5.1.4
$D_o$	Initial column imperfection	D4.1
$d$	Depth of section	B1.1b, B4, C3.1.1, C3.1.3, D1.1, D3.2.1, D4, D4.1
$d$	Width of arc seam weld	E2.3
$d$	Visible diameter of outer surface of arc spot weld	E2.2
$d$	Diameter of bolt	E3, E3.1, E3.2, E3.4

$d_a$	Average diameter of the arc spot weld at mid-thickness of $t$	E2.2
$d_a$	Average width of seam weld	E2.3
$d_e$	Effective diameter of fused area	E2.2
$d_e$	Effective width of arc seam weld at fused surfaces	E2, E2.3
$d_h$	Diameter of standard hole	B2.2, E3.1, E4
$d_s$	Reduced effective width of stiffener	B4, B4.2
$d'_s$	Actual effective width of stiffener	B4, B4.2
$d_{wc}$	Coped web depth	E4
$E$	Modulus of elasticity of steel ( $29.5 \times 10^3$ ksi) ( $203\ 255$ N/mm <sup>2</sup> )	B1.1b, B2.1, B6.1, C3.1.1 C3.2, C3.5, C4, C4.1, C5, C6.1, D1.2, D4.1, D4.2, E2.2
$E$	Nominal earthquake load	A5.1.4
$E_o$	Initial column imperfection; a measure of the initial twist of the stud from the initial, ideal, unbuckled location	D4.1
$E_l$	Term used to compute shear strain in wallboard	D4.1
$E'$	Inelastic modulus of elasticity	D4.1
$e$	The distance measured in the line of force from the center of a standard hole to the nearest edge of an adjacent hole or to the end of the connected part toward which the force is directed	E3.1
$e_{min}$	Minimum allowable distance measured in the line of force from the centerline of a weld to the nearest edge of an adjacent weld or to the end of the connected part toward which the force is directed	E2.2
$e_y$	Yield strain = $F_y/E$	C3.1.1
$F$	Loads due to fluids	A5.1.4
$F_e$	Elastic buckling stress	C4, C4.1, C4.2, C4.3, C6.2, D4.1
$F_m$	Mean value of the fabrication factor	F1
$F_n$	Nominal buckling stress	C4, C6.2, D4.1
$F_{nt}$	Nominal tensile strength of bolts	E3.4
$F_{nv}$	Nominal shear strength of bolts	E3.4
$F'_{nt}$	Nominal tensile strength for bolts subject to combination of shear and tension	E3.4
$F_{sy}$	Yield point as specified in Sections A3.1 or A3.2	A3.1, A3.2, A3.3.2, E2.2, E3.1, E3.2
$F_u$	Tensile strength as specified in Sections A3.1 or A3.2, or as reduced for low ductility steel	A3.1, A3.2, A3.3, A3.3.2, E2.2, E2.3, E2.4, E2.5, E3.1, E3.2, E3.3, E4
$F_{uv}$	Tensile strength of virgin steel specified by Section A3 or established in accordance with Section F3.3	A3, A5.2.2, E2.2, F3.3
$F_{wy}$	Yield point for design of transverse stiffeners	B6.1
$F_{xx}$	Strength level designation in AWS electrode classification	E2.2, E2.3, E2.4, E2.5
$F_y$	Yield point used for design, not to exceed the specified yield point or established in accordance with Section F3, as increased for cold work of forming in Section A5.2.2 or as reduced for low ductility steels in Section A3.3.2	A1.2, A3.3, A5.2.1, A5.2.2, B2.1, B5, B6.1, C2, C3.1, C3.1.1 C3.1.3, C3.2, C3.5, C4, C6.1, C6.2, D1.2, D4, D4.2, E2

$F_{ya}$	Average yield point of section	A5.2.2
$F_{yc}$	Tensile yield point of corners	A5.2.2
$F_{yf}$	Weighted average tensile yield point of the flat portions	A5.2.2, F3.2
$F_{ys}$	Yield point of stiffener steel	B6.1
$F_{yv}$	Tensile yield point of virgin steel specified by Section A3 or established in accordance with Section F3.3	A3, A5.2.2, F3.3
$f$	Stress in the compression element computed on the basis of the effective design width	B2.1, E2.2, B3.2, B4, B4.1
$f_{av}$	Average computed stress in the full, unreduced flange width	B1.1b
$f_c$	Stress at service load in the cover plate or sheet	D1.2
$f'_c$	Specified compression stress of concrete	E5.1
$f_d$	Computed compressive stress in the element being considered. Calculations are based on the effective section at the load for which deflections are determined.	B2.1, B2.2, B3.1, B4.1, B4.2
$f_{d1}, f_{d2}$	Computed stresses $f_1$ and $f_2$ as shown in Figure B2.3-1. Calculations are based on the effective section at the load for which deflections are determined	B2.3
$f_{d3}$	Computed stress $f_3$ in edge stiffener, as shown in Figure B4-2. Calculations are based on the effective section at the load for which deflections are determined	B3.2
$f_v$	Computed shear stress on a bolt	E4
$f_1, f_2$	Web stresses defined by Figure B2.3-1	B2.3
$f_3$	Edge stiffener stress defined by Figure B4-2	B3.2
$G$	Shear modulus of steel (11,300 ksi) (77 857 N/mm <sup>2</sup> )	C3.1.1, D4.1
$G'$	Inelastic shear modulus	D4.1
$g$	Vertical distance between two rows of connections nearest to the top and bottom flanges	D1.1
$H$	Loads due to the weight and lateral pressure of soil and water in soil	A5.1.4
$h$	Depth of flat portion of web measured along the plane of web	B1.2, B6.2, C3.2, C3.4
$I_a$	Adequate moment of inertia of stiffener so that each component element will behave as a stiffened element	B1.1, B4, B4.1, B4.2
$I_b$	Moment of inertia of the full unreduced section about the bending axis	C5
$I_s$	Actual moment of inertia of the full stiffener about its own centroidal axis parallel to the element to be stiffened	B1.1, B4, B4.1, B4.2, B5
$I_{sf}$	Moment of inertia of the full area of the multiple stiffened element, including the intermediate stiffeners, about its own centroidal axis parallel to the element to be stiffened	B5
$I_x, I_y$	Moment of inertia of full section about principal axis	D1.1, D3.2.2
$I_{xy}$	Product of inertia of full section about major and minor centroidal axes	D3.2.2, D4.1
$I_{yc}$	Moment of inertia of the compression portion of a section about the centroidal axis of the entire section parallel to the web, using the full unreduced section	C3.1.2
$J$	St. Venant torsion constant	C3.1.2

j	Section property for torsional-flexural buckling	C3.1.2
K	Effective length factor	C3.1.2, C4, C4.1, C5
K'	A constant	D3.2.2
K <sub>b</sub>	Effective length factor in the plane of bending	C5
K <sub>t</sub>	Effective length factor for torsion	C3.1.2
K <sub>x</sub>	Effective length factor for bending about x-axis	C3.1.2
K <sub>y</sub>	Effective length factor for bending about y-axis	C3.1.2
k	Plate buckling coefficient	B2.1, B2.3, B3.1, B3.2, B4, B4.1, B4.2
k <sub>v</sub>	Shear buckling coefficient	B6.2, C3.2
L	Full span for simple beams, distance between inflection points for continuous beams, twice the length of cantilever beams	B1.1c, D3.2.1
L	Length of seam weld not including the circular ends	E2.3
L	Length of fillet weld	E2.4, E2.5
L	Unbraced length of member	C3.1.2, C4.1, D1.1, D4, D4.1
L	Nominal live load	A5.1.4
L <sub>r</sub>	Nominal roof live load	A5.1.4
L <sub>st</sub>	Length of transverse stiffener	B6.1
L <sub>t</sub>	Unbraced length of compression member for torsion	C3.1.2
L <sub>x</sub>	Unbraced length of compression member for bending about x-axis	C3.1.2
L <sub>y</sub>	Unbraced length of compression member for bending about y-axis	C3.1.2
M <sub>c</sub>	Critical moment	C3.1.2
M <sub>e</sub>	Elastic critical moment	C3.1.2
M <sub>m</sub>	Mean value of the material factor	F1
M <sub>n</sub>	Nominal flexural strength	C3.1, C3.1.1, C3.1.2, C3.1.3, C6.1
M <sub>nx</sub> , M <sub>ny</sub>	Nominal flexural strengths about the centroidal axes determined in accordance with Section C3	C5
M <sub>nxo</sub> , M <sub>nyo</sub>	Nominal flexural strengths about the centroidal axes determined in accordance with Section C3.1 excluding the provisions of Section C3.1.2	C3.3, C3.5 D4.2, D4.3
M <sub>u</sub>	Required flexural strength	C3.3, C3.5
M <sub>ux</sub>	Required flexural strength about x-axis	C5
M <sub>uy</sub>	Required flexural strength about y-axis	C5
M <sub>y</sub>	Moment causing a maximum strain e <sub>y</sub>	B2.1, C3.1
M <sub>1</sub>	Smaller end moment	C3.1.2, C5
M <sub>2</sub>	Larger end moment	C3.1.2, C5
m	Distance from the shear center of one channel to the mid-plane of its web	D1.1, D3.2.2
N	Actual length of bearing	D3.6
n	Number of holes	E4
n	Number of tests	F1
n <sub>p</sub>	Number of parallel purlin lines	D3.2.1
P	Loads, forces, and effects due to ponding	A5.1.4
P <sub>E</sub>	$\pi^2 EI_b / (K_b L_b)^2$	C5

$P_L$	Force to be resisted by intermediate beam brace	D3.2.1
$P_m$	Mean value of the tested-to-predicted load ratios	F1
$P_n$	Nominal axial strength of member	C4, C6.2
$P_n$	Nominal strength of connection component	E2, E2.2, E2.3, E2.4, E2.5
$P_{no}$	Nominal axial strength of member determined in accordance with Section C4 for $L = 0$	C5
$P_p$	Nominal bearing capacity on concrete	E5.1
$P_s$	Concentrated load or reaction based on factored loads	D1.1
$P_u$	Required axial strength	C5
$\bar{Q}$	Design shear rigidity for sheathing on both sides of the wall assembly	D4.1
$Q_i$	Load effect	F1
$q$	Uniformly distributed factored load in the plane of the web	D1.1
$\bar{q}$	Design shear rigidity for sheathing per inch of stud spacing	D4.1
$\bar{q}_o$	Factor used to determine design shear rigidity	D4.1
$R$	Reduction Factor	C3.1.3
$R$	Coefficient	C4, C6.2
$R$	Inside bend radius	A5.2.2, C3.4
$R_n$	Nominal resistance	A1.2, F1
$R_p$	Average value of all test results	F1
$R_r$	Nominal roof rain load	A5.1.4
$r$	Radius of gyration of full unreduced cross section	C3.1.1, C4, C4.1
$r$	Force transmitted by the bolt or bolts at the section considered, divided by the tension force in the member at that section	E3.2
$r_{cy}$	Radius of gyration of one channel about its centroidal axis parallel to web	D1.1
$r_l$	Radius of gyration of I-section about the axis perpendicular to the direction in which buckling would occur for the given conditions of end support and intermediate bracing	D1.1
$r_o$	Polar radius of gyration of cross section about the shear center	C3.1.1, C4.2, D4.1
$r_x, r_y$	Radius of gyration of cross section about centroidal principal axis	C3.1.1
$S$	$1.28 \sqrt{E/f}$	B4, B4.1
$S$	Nominal snow load	A5.1.4
$S_c$	Elastic section modulus of the effective section calculated at a stress $M_c/S_f$ in the extreme compression fiber	C3.1.1, C3.1.2, C4
$S_e$	Elastic section modulus of the effective section calculated with extreme compression or tension fiber at $F_y$	C3.1.1, C3.1.3
$S_f$	Elastic section modulus of full, unreduced section for the extreme compression fiber	C3.1.1, C3.1.2, C6.1
$s_{max}$	Maximum permissible longitudinal spacing of welds or other connectors joining two channels to form an I-section	D1.1
$s$	Fastener spacing	D1.2, D4.1

s	Spacing in line of stress of welds, rivets, or bolts connecting a compression coverplate or sheet to a non-integral stiffener or other element	E3.2
s	Weld spacing	D1.1
$T_n$	Nominal tensile strength	C2
$T_s$	Design strength of connection in tension	D1.1
t	Base steel thickness of any element or section	A1.2, A3.4, A5.2.1, B1.1, B1.1b, B1.2, B2.1, B4, B4.1, B4.2, B5, B6.1, C3.1.1., C3.2, C3.4, C3.5, C4, C6.1, C5.2, D1.2, D4, E2.4, E2.5
t	Total thickness of the two welded sheets	E2.2
t	Thickness of thinnest connected part	E2.2, E3.1, E4
$t_s$	Equivalent thickness of a multiple-stiffened element	B5, B6.1
$t_w$	Effective throat of weld	E2.4, E2.5
$V_F$	Coefficient of variation of the fabrication factor	F1
$V_M$	Coefficient of variation of the material factor	F1
$V_n$	Nominal shear strength	B6.2, C3.2, C3.3
$V_P$	Coefficient of variation of the tested-to-predicted load ratios	F1
$V_Q$	Coefficient of variation of the load effect	F1
$V_u$	Required shear strength	C3.3
W	Factored load supported by all purlin lines being restrained	D3.2.1
W	Nominal wind load	A5.1.4
w	Flat width of element exclusive of radii	A1.2, B1.1, B2.1, B2.2, B3.1, B4, B4.1, B4.2, B5, C3.1.1, C4, D1.2
w	Flat width of the beam flange which contacts the bearing plate	C3.5
$w_f$	Width of flange projection beyond the web or half the distance between webs for box- or U-type sections	B1.1c
$w_f$	Projection of flanges from inside face of web	B1.1b, D1.1
$w_1$	Leg on weld	E2.4
$w_2$	Leg on weld	E2.4
x	Distance from concentrated load to brace	D3.2
$x_o$	Distance from shear center to centroid along the principal x-axis	C3.1.1, C4.2, D4.1
Y	Yield point of web steel divided by yield point of stiffener steel	B6.2
$1/a_{nx}$ , $1/a_{ny}$	Magnification factors	C5
$\beta$	Coefficient	C4.2, D4.1
$\beta_o$	Target reliability index	F1
$\gamma$	Actual shear strain in the sheathing	D4.1
$\bar{\gamma}$	Permissible shear strain of the sheathing	D4.1
$\gamma_i$	Load factor	F1
$\theta$	Angle between web and bearing surface $>45^\circ$ but no more than $90^\circ$	C3.4
$\theta$	Angle between the vertical and the plane of the web of the Z-section, degrees	D3.2.1

$\sigma$	Stress related to shear strain in sheathing	D4.1
$\sigma_{CR}$	Theoretical elastic buckling stress	D4.1
$\sigma_{ex}$	$(\pi^2 E)/(K_x L_x/r_x)^2$ $(\pi^2 E)/(L/r_x)^2$	C3.1.2, C4.2 D4.1
$\sigma_{exy}$	$(\pi^2 E I_{xy})/(AL^2)$	D4.1
$\sigma_{ey}$	$(\pi^2 E)/(K_y L_y/r_y)^2$ $(\pi^2 E)/(L/r_y)^2$	C3.1.2 D4.1
$\sigma_t$	Torsional buckling stress	C3.1.1, C4.2, D4.1
$\rho$	Reduction factor	B2.1
$\lambda, \lambda_c$	Slenderness factors	B2.1, C3.5
$\psi$	$f_2/f_1$	B2.3
$\phi$	Resistance factor	A5.1.5, E2, E2.1, E2.2, E2.3, E2.4, E2.5, E2.6, E3.1, E3.2, E3.3, E3.4, E4, F1
$\phi_b$	Resistance factor for bending strength	A5.1.5, C3, C3.1.1, C3.1.2, C3.1.3, C3.3, C3.5, C5, C6.1, C6.3, D4.2, D4.3
$\phi_c$	Resistance factor for concentrically loaded compression member	A3.3.1, A5.1.5, B6.1, C4, C5, C6.2, C6.3, D4.1, D4.3
$\phi_c$	Resistance factor for bearing strength	E5.1
$\phi_t$	Resistance factor for tension member	C2
$\phi_v$	Resistance factor for shear strength	B6.2, C3.2, C3.3
$\phi_w$	Resistance factor for web crippling strength	C3.4, C3.5

## A. GENERAL PROVISIONS

A1 Limits of Applicability and Terms. A1.1 Scope and Limits of Applicability. This Load and Resistance Factor Design Specification is an alternate to the Specification for the Design of Cold-Formed Steel Structural Members of the American Iron and Steel Institute.

This Specification shall apply to the design of structural members cold-formed to shape from carbon or low-alloy steel sheet, strip, plate or bar not more than one inch in thickness and used for load-carrying purposes in buildings. It may also be used for structures other than buildings provided appropriate allowances are made for thermal and/or dynamic effects.

A1.2 Terms. (See also Part I of the standard for additional terms.) Where the following terms appear in this Specification they shall have the meaning herein indicated:

- (a) *Stiffened or Partially Stiffened Compression Elements.* A stiffened or partially stiffened compression element is a flat compression element (i.e., a plane compression flange of a flexural member or a plane web or flange of a compression member) of which both edges parallel to the direction of stress are stiffened either by a web, flange, stiffening lip, intermediate stiffener, or the like.
- (b) *Unstiffened Compression Elements.* An unstiffened compression element is a flat compression element which is stiffened at only one edge parallel to the direction of stress.
- (c) *Multiple-Stiffened Elements.* A multiple-stiffened element is an element that is stiffened between webs, or between a web and a stiffened edge, by means of intermediate stiffeners which are parallel to the direction of stress. A *sub-element* is the portion between adjacent stiffeners or between web and intermediate stiffener or between edge and intermediate stiffener.
- (d) *Flat-Width-to-Thickness Ratio.* The flat width of an element measured along its plane, divided by its thickness.

- (e) *Effective Design Width.* Where the flat width of an element is reduced for design purposes, the reduced design width is termed the effective width or effective design width.
- (f) *Thickness.* The thickness,  $t$ , of any element or section shall be the base steel thickness, exclusive of coatings.
- (g) *Torsional-Flexural Buckling.* Torsional-flexural buckling is a mode of buckling in which compression members can bend and twist simultaneously.
- (h) *Point-Symmetric Section.* A point-symmetric section is a section symmetrical about a point (centroid) such as a Z-section having equal flanges.
- (i) *Yield Point.* Yield point,  $F_y$  or  $F_{sy}$ , as used in this Specification shall mean yield point or yield strength.
- (j) *Stress.* Stress as used in this Specification means force per unit area.
- (k) *Confirmatory Test.* A confirmatory test is a test made, when desired, on members, connections, and assemblies designed according to the provisions of Sections A through E of this Specification or its specific references, in order to compare actual versus calculated performance.
- (l) *Performance Test.* A performance test is a test made on structural members, connections, and assemblies whose performance cannot be determined by the provisions of Sections A through E of this Specification or its specific references.
- (m) *Virgin Steel.* Virgin steel refers to steel as received from the steel producer or warehouse before being cold worked as a result of fabricating operations.
- (n) *Virgin Steel Properties.* Virgin steel properties refer to mechanical properties of virgin steel such as yield point, tensile strength, and elongation.
- (o) *Specified Minimum Yield Point.* The specified minimum yield point is the lower limit of yield point which must be equalled or exceeded in a specification test to qualify a lot of steel for use in a cold-formed steel structural member designed at that yield point.
- (p) *Cold-Formed Steel Structural Members.* Cold-formed steel structural members are shapes which are manufactured by press-braking blanks sheared from sheets, cut lengths of coils or plates, or by roll forming cold- or hot-rolled coils or sheets; both forming operations being performed at ambient room temperature, that is, without manifest addition of heat such as would be required for hot forming.
- (q) *LRFD (Load and Resistance Factor Design).* A method of proportioning structural components (members, connectors, connecting elements and assemblages) such that no applicable limit state is exceeded when the structure is subjected to all appropriate load combinations.
- (r) *Design Strength.* Factored resistance or strength (force, moment, as appropriate),  $\phi R_n$ , provided by the structural component.
- (s) *Required Strength.* Load effect (force, moment, as appropriate) acting on the structural component determined by structural analysis from the factored loads (using most appropriate critical load combinations).

A1.3 Units of Symbols and Terms. The Specification is written so that any compatible system of units may be used except where explicitly stated otherwise in the text of these provisions.

A2 Non-Conforming Shapes and Construction. The provisions of the Specification are not intended to prevent the use of alternate shapes or constructions not specifically prescribed herein. Such alternates shall meet the provisions of Section F of the Specification and be approved by the appropriate building code authority.

A3 Material. A3.1 Applicable Steels. This Specification requires the use of steel of structural quality as defined in general by the provisions of the following specifications of the American Society for Testing and Materials:

- ASTM A36/A36M, Structural Steel
- ASTM A242/A242M, High-Strength Low-Alloy Structural Steel
- ASTM A441M, High-Strength Low-Alloy Structural Manganese Vanadium Steel
- ASTM A446/A446M (Grades A, B, C, D, & F) Steel, Sheet, Zinc-Coated (Galvanized) by the Hot-Dip Process, Structural (Physical) Quality
- ASTM A500, Cold-Formed Welded and Seamless Carbon Steel Structural Tubing in Rounds and Shapes
- ASTM A529/A529M, Structural Steel with 42 ksi Minimum Yield Point (1/2 in. Maximum Thickness)
- ASTM A570/A570M Steel, Sheet and Strip, Carbon, Hot-Rolled, Structural Quality
- ASTM A572/A572M, High-Strength Low-Alloy Columbium-Vanadium Steels of Structural Quality
- ASTM A588/A588M, High-Strength Low-Alloy Structural Steel with 50 ksi Minimum Yield Point to 4 in. Thick
- ASTM A606 Steel, Sheet and Strip, High Strength, Low Alloy, Hot-Rolled and Cold-Rolled, with Improved Atmospheric Corrosion Resistance
- ASTM A607 Steel Sheet and Strip, High Strength, Low Alloy, Columbium or Vanadium, or both, Hot-Rolled and Cold-Rolled
- ASTM A611 (Grades A, B, C, & D) Steel, Sheet, Carbon, Cold-Rolled, Structural Quality
- ASTM A715 (Grades 50 and 60) Sheet Steel and Strip, High-Strength, Low-Alloy, Hot-Rolled, With Improved Formability
- ASTM A792 (Grades 33, 37, 40 & 50) Steel Sheet, Aluminum-Zinc Alloy-Coated by the Hot-Dip Process, General Requirements

A3.2 Other Steels. The listing in Section A3.1 does not exclude the use of steel up to and including one inch in thickness ordered or produced to other than the listed specifications provided such steel conforms to the chemical and mechanical requirements of one of the listed specifications or other published specification which establishes its properties and suitability, and provided it is subjected by either the producer or the purchaser to analyses, tests and other controls to the extent and in the manner prescribed by one of the listed specifications and Section A3.3.

A3.3 Ductility. Steels not listed in Section A3.1 and used for structural members and connections shall comply with one of the following ductility requirements:

A3.3.1 The ratio of tensile strength to yield point shall not be less than 1.08 and the total elongation shall not be less than 10 percent for a two-inch (51 mm) gage length or 7 percent for an eight-inch (203 mm) gage length standard specimen tested in accordance with ASTM A370. If these requirements cannot be met, the following criteria shall be satisfied: (1) local elongation in a 1/2 inch (13 mm) gage length across the fracture shall not be less than 20%, (2) uniform elongation outside the fracture shall not be less than 3%. When material ductility is determined on the basis of the local and uniform elongation criteria, the use of such material is restricted to the design of purlins and girts\*\* in accordance with Sections C3.1.1(a), C3.1.2, and C3.1.3. For purlins and girts subject to combined axial load and bending moment (Section C5),  $P_u/\phi_c P_n$  shall not exceed 0.15.

A3.3.2 Steels conforming to ASTM A446 Grade E and A611 Grade E and other steels which do not meet the provisions of Section A3.3.1 may be used for particular configurations provided (1) the yield strength,  $F_y$ , used for design in Chapters B, C and D is taken as 75 percent of the specified minimum yield point or 60 ksi (413 N/mm<sup>2</sup>), whichever is less and (2) the tensile strength,  $F_u$ , used for design in Chapter E is taken as 75 percent of the specified minimum tensile stress or 62 ksi (427 N/mm<sup>2</sup>), whichever is less. Alternatively, the suitability of such steels for the configuration shall be demonstrated by load tests in accordance with Section F1. Design strengths based on these tests

shall not exceed the strengths calculated according to Chapters B through E, using the specified minimum yield point,  $F_{sy}$ , for  $F_y$  and the specified minimum tensile strength,  $F_u$ .

Design strengths based on existing use shall not exceed the strengths calculated according to Chapters B through E, using the specified minimum yield point,  $F_{sy}$ , for  $F_y$  and the specified minimum tensile strength,  $F_u$ .

**A3.4 Delivered Minimum Thickness.** The uncoated minimum steel thickness of the cold-formed product as delivered to the job site shall not at any location be less than 95 percent of the thickness,  $t$ , used in its design; however, lesser thicknesses shall be permitted at bends, such as corners, due to cold-forming effects.

A4 Loads. A4.1 Dead Load (Deleted)

A4.2 Live or Snow Load (Deleted)

A4.3 Impact Load. For structures carrying live loads which induce impact, the assumed live load shall be increased sufficiently to provide for impact.

A4.4 Wind or Earthquake Loads (Deleted)

A4.5 Ponding. Unless a roof surface is provided with sufficient slope toward points of free drainage or adequate individual drains to prevent the accumulation of rainwater, the roof system shall be investigated by rational analysis to assure stability under ponding conditions.

**A5 Structural Analysis and Design.** A5.1 Design Basis. This Specification is based on the Load and Resistance Factor Design concept. Load and Resistance Factor Design is a method of proportioning cold-formed steel structural components (i.e., members, connectors and connections) such that any applicable limit state is not exceeded when the structure is subjected to any appropriate load combination.

Two types of limit states are to be considered: 1) the limit state of the strength required to resist the extreme loads during the intended life of the structure, and 2) the limit state of the ability of the structure to perform its intended function during its life. These limit states will be called the Limit State of Strength and the Limit State of Serviceability, respectively, in these criteria.

**A5.1.1 Limit State—Strength.** The design meets this Specification when the required strengths, as determined from the assigned nominal loads which are multiplied by appropriate load factors, are smaller than or equal to the design strength of each structural component.

The design strength is equal to  $\phi R_n$ , where  $\phi$  is a resistance factor and  $R_n$  is the nominal strength determined according to the formulas given in Chapter C for members, in Chapter D for structural assemblies and in Chapter E for connections. Values of resistance factors  $\phi$  are given in Section A5.1.5 for the appropriate limit states governing member and connection strength.

**A5.1.2 Limit State—Serviceability.** Serviceability is satisfactory if a nominal structural response (e.g. live load deflection) due to the applicable nominal loads is less than or equal to the appropriate acceptable or allowable value of this response.

A5.1.3 Nominal Loads (Amended see Part I)

**A5.1.4 Load Factors and Load Combinations.** The structure and its components must be designed for the appropriate most critical load combination. The following load combinations of the factored nominal loads shall be used in the computation of the required strengths:

1.  $1.4 D + L$
2.  $1.2 D + 1.6 L + 0.5(L_r \text{ or } S \text{ or } R_r)$
3.  $1.2 D + (1.4 L_r \text{ or } 1.6 S \text{ or } 1.6 R_r) + (0.5 L \text{ or } 0.8 W)$
4.  $1.2 D + 1.3 W + 0.5 L + 0.5(L_r \text{ or } S \text{ or } R_r)$
5.  $1.2 D + 1.5 E + (0.5 L \text{ or } 0.2 S)$
6.  $0.9 D - (1.3 W \text{ or } 1.5 E)$

**WHERE:**

- t = Web thickness
- D = nominal dead load
- E = nominal earthquake load
- L = nominal live load
- L<sub>r</sub> = nominal roof live load
- R<sub>r</sub> = nominal roof rain load
- S = nominal snow load
- W = nominal wind load (Exception: For wind load on individual purlins, girts, wall panels and roof decks, multiply the load factor for W by 0.9)

**EXCEPTION:** The load factor for L in combinations (3), (4), and (5) shall be equal to 1.0 for garages, areas occupied as places of public assembly, and all areas where the live load is greater than 100 psf (4.79 kN/m<sup>2</sup>).

When the structural effects of F, H, P or T are significant, they shall be considered in design as the following factored loads: 1.3F, 1.6H, 1.2P, and 1.2T, where

- F = loads due to fluids with well-defined pressures and maximum heights
- H = loads due to the weight and lateral pressure of soil and water in soil
- P = loads, forces, and effects due to ponding
- T = self-straining forces and effects arising from contraction or expansion resulting from temperature change, shrinkage, moisture changes, creep in component materials, movement due to differential settlement, or combinations thereof.

A5.1.5 Resistance Factors. The resistance factors to be used for determining the design strengths,  $\phi R_n$ , of structural members and connections shall be taken as follows:

**Type of Strength Resistance Factor,  $\phi$**

(a) Stiffeners	
Transverse stiffeners	0.85
Shear stiffeners (When $h/t \leq \sqrt{Ek_v/F_y}$ , $\phi = 1.0$ )	0.90
(b) Tension members	0.95
(c) Flexural members	
Bending strength	
For sections with stiffened or partially stiffened compression flanges	0.95
For sections with unstiffened compression flanges	0.90
Laterally unbraced beams	0.90
Beams having one flange through-fastened to deck or sheathing (C- or Z-sections)	0.90
Web design	
Shear strength (when $h/t \leq \sqrt{Ek_v/F_y}$ , $\phi = 1.0$ )	0.90
Web Crippling	
For single unreinforced webs	0.75
For I-sections	0.80
(d) Concentrically loaded compression members	0.85
(e) Combined axial load and bending	
$\phi_c$ for compression	0.85
$\phi_b$ for bending	
Using Section C3.1.1	0.90-0.95
Using Section C3.1.2	0.90
(f) Cylindrical tubular members	
Bending strength	0.95

	Axial compression .....	0.85
(g)	Wall studs and wall stud assemblies	
	Wall studs in compression .....	0.85
	Wall studs in bending	
	For sections with stiffened or partially stiffened compression flanges ....	0.95
	For sections with unstiffened compression flanges .....	0.90
(h)	Welded connections	
	Groove welds	
	Tension or compression .....	0.90
	Shear (welds) .....	0.80
	Shear (base metal) .....	0.90
	Arc spot welds	
	Welds .....	0.60
	Connected part .....	0.50-0.65
	Minimum edge distance .....	0.60-0.70
	Arc seam welds	
	Welds .....	0.60
	Connected part .....	0.60
	Fillet welds	
	Longitudinal loading (connected part) .....	0.55-0.60
	Transverse loading (connected part) .....	0.60
	Welds .....	0.60
	Flare groove welds	
	Transverse loading (connected part) .....	0.55
	Longitudinal loading (connected part) .....	0.55
	Welds .....	0.60
	Resistance Welds .....	0.65
(i)	Bolted connections	
	Minimum spacing and edge distance .....	0.60-0.70
	Tension strength on net section	
	With washers	
	Double shear connection .....	0.65
	Single shear connection .....	0.55
	Without washers .....	0.65
	Bearing strength	
	See Tables E3.3-1 and E3.3-2 .....	0.55-0.70
	Shear strength of bolts .....	0.65
	Tensile strength of bolts .....	0.75
(j)	Shear rupture .....	0.75
(k)	Connections to other materials (Bearing) .....	0.60

A5.2 Yield Point and Strength Increase from Cold Work of Forming. A5.2.1 Yield Point. The yield point used in design,  $F_y$ , shall not exceed the specified minimum yield point of steels as listed in Section A3.1 or A3.2, as established in accordance with Chapter F, or as increased for cold work of forming in Section A5.2.2, or as reduced for low ductility steels in Section A3.3.2.

A5.2.2 Strength Increase from Cold Work of Forming. Strength increase from cold work of forming is allowed by substituting  $F_{ya}$  for  $F_y$ , where  $F_{ya}$  is the average yield point of the full section. Such increase shall be limited to Sections C3.1 (excluding Section C3.1.1(b)), C4, C5, C6 and D4. The limitations and methods for determining  $F_{ya}$  are as follows:

- (a) For axially loaded compression members and flexural members whose proportions are such that the quantity  $\rho$  for load capacity is unity as determined according to Section B2 for each of

the component elements of the section, the design yield stress,  $F_{ya}$ , of the steel shall be determined on the basis of one of the following methods:

- (1) full section tensile tests [see paragraph (a) of Section F3.1]
- (2) stub column tests [see paragraph (b) of Section F3.1]
- (3) computed as follows:

$$F_{ya} = CF_{yc} + (1-C)F_{yf} \quad (\text{Eq. A5.2.2-1})$$

**WHERE:**

$F_{ya}$  = Average yield point of the steel in the full section of compression members or full flange sections of flexural members

$C$  = For compression members, ratio of the total corner cross-sectional area to the total cross-sectional area of the full section; for flexural members, ratio of the total corner cross-sectional area of the controlling flange to the full cross-sectional area of the controlling flange

$F_{yf}$  = Weighted average tensile yield point of the flat portions established in accordance with Section F3.2 or virgin steel yield point if tests are not made

$F_{yc}$  =  $B_c F_{yv} / (R/t)^m$ , tensile yield point of corners. This formula is applicable (Eq. A5.2.2-2) only when  $F_{uv}/F_{yv} \geq 1.2$ ,  $R/t \leq 7$ , and minimum included angle  $\leq 120^\circ$

$$B_c = 3.69 (F_{uv}/F_{yv}) - 0.819 (F_{uv}/F_{yv})^2 - 1.79 \quad (\text{Eq. A5.2.2-3})$$

$$m = 0.192 (F_{uv}/F_{yv}) - 0.068 \quad (\text{Eq. A5.2.2-4})$$

$R$  = Inside bend radius.

$F_{yv}$  = Tensile yield point of virgin steel specified by Section A3 or established in accordance with Section F3.3

$F_{uv}$  = Ultimate tensile strength of virgin steel specified by Section A3 or established in accordance with Section F3.3

- (b) For axially loaded tension members the yield point of the steel shall be determined by either method (1) or method (3) prescribed in paragraph (a) of this Section.
- (c) The effect of any welding on mechanical properties of a member shall be determined on the basis of tests of full section specimens containing within the gage length, such welding as the manufacturer intends to use. Any necessary allowance for such effect shall be made in the structural use of the member.

**A5.3 Durability.** A structure shall be designed to perform its required functions during its expected life for durability considerations.

**A6 Reference Documents.** The following documents are referenced in this Specification:

1. American Society of Civil Engineers, ANSI/ASCE 7-88, "Minimum Design Loads in Buildings and Other Structures," American Society of Civil Engineers (ASCE), 345 East 47th Street, New York, N.Y. 10017
2. American Institute of Steel Construction, "Load and Resistance Factor Design Specification for Structural Steel Buildings," American Institute of Steel Construction (AISC), One East Wacker Drive, Suite 3100, Chicago, Illinois 60601-2001, September 1, 1986
3. American Welding Society, AWS D1.3-89, "Structural Welding Code—Sheet Steel," American Welding Society (AWS), 550 N.W. LeJeune Road, Miami, Florida 33135
4. American Welding Society, AWS C1.1-66, "Recommended Practices for Resistance Welding," American Welding Society (AWS), 550 N.W. LeJeune Road, Miami, Florida 33135
5. American Welding Society, AWS C1.3-70, "Recommended Practices for Resistance Welding Coated Low Carbon Steels," American Welding Society (AWS), 550 N.W. LeJeune Road, Miami, Florida 33135

6. American Society for Testing and Materials (ASTM), 1916 Race Street, Philadelphia, Pennsylvania 19013:

ASTM A36/A36M-84a, Structural Steel

ASTM A194-88, Carbon and Alloy Steel Nuts for Bolts for High-Pressure and High-Temperature Service

ASTM A242/A242M-85, High-Strength Low-Alloy Structural Steel

ASTM A307-84 (Type A), Carbon Steel Externally and Internally Threaded Standard Fasteners

ASTM A325-84, High Strength Bolts for Structural Steel Joints

ASTM A354-84 (Grade BD), Quenched and Tempered Alloy Steel Bolts, Studs, and Other Externally Threaded Fasteners (for diameter of bolt smaller than  $\frac{1}{2}$  inch)

ASTM A370-77, Mechanical Testing of Steel Products

ASTM A441M-85, High-Strength Low-Alloy Structural Manganese Vanadium Steel

ASTM A446/A446M-85 (Grades A, B, C, D, and F), Steel, Sheet, Zinc-Coated (Galvanized) by the Hot-Dip Process, Structural (Physical) Quality

ASTM A449-84a, Quenched and Tempered Steel Bolts and Studs (for diameter of bolt smaller than  $\frac{1}{2}$  inch)

ASTM A490-84, Quenched and Tempered Alloy Steel Bolts for Structural Steel Joints.

ASTM A500-84, Cold-Formed Welded and Seamless Carbon Steel Structural Tubing in Rounds and Shapes

ASTM A529/A529M-85, Structural Steel with 42 ksi Minimum Yield Point ( $\frac{1}{2}$  in. Maximum Thickness)

ASTM A563-88a, Carbon and Alloy Steel Nuts

ASTM A570/A570M-85, Steel, Sheet and Strip, Carbon, Hot-Rolled, Structural Quality

ASTM A572/A572M-85, High-Strength Low-Alloy Columbium-Vanadium Steels of Structural Quality

ASTM A588/A588M-85, High-Strength Low-Alloy Structural Steel with 50 ksi Minimum Yield Point to 4 in. Thick

ASTM A606-85, Steel, Sheet and Strip, High Strength, Low Alloy, Hot-Rolled and Cold-Rolled, with Improved Atmospheric Corrosion Resistance

ASTM A607-85, Steel Sheet and Strip, High Strength, Low Alloy, Columbium or Vanadium, or both, Hot-Rolled and Cold-Rolled

ASTM A611-85 (Grades A, B, C, and D), Steel, Sheet, Carbon, Cold-Rolled, Structural Quality

ASTM A715-85 (Grades 50 and 60), Sheet Steel and Strip, High-Strength, Low-Alloy, Hot-Rolled, With Improved Formability

ASTM A792-85a (Grades 33, 37, 40 and 50), Steel Sheet, Aluminum-Zinc Alloy-Coated by the Hot-Dip Process, General Requirements

ASTM F436-86, Hardened Steel Washers

ASTM F844-83(1988), Washers, Steel, Plain (Flat), Unhardened for General Use

ASTM F959-85, Compressible Washer-Type Direct Tension Indicators for Use with Structural Fasteners

**B. ELEMENTS**

B1 Dimensional Limits and Considerations. B1.1 Flange Flat-Width-to-Thickness Considerations.

(a) *Maximum Flat-Width-to-Thickness Ratios*

Maximum allowable overall flat-width-to-thickness ratios,  $w/t$ , disregarding intermediate stiffeners and taking as  $t$  the actual thickness of the element, shall be as follows:

- |   |     |
|---|-----|
| (1) Stiffened compression element having <i>one</i> longitudinal edge connected to a web or flange element, the other stiffened by:     |     |
| Simple lip  | 60  |
| Any other kind of stiffener having $I_s > I_a$ and $D/w < 0.8$ according to Section B4.2  | 90  |
| (2) Stiffened compression element with <i>both</i> longitudinal edges connected to other stiffened elements                             | 500 |
| (3) Unstiffened compression element and elements with an edge stiffener having $I_s < I_a$ and $D/w \leq 0.8$ according to Section B4.2 | 60  |

**Note:** Unstiffened compression elements that have  $w/t$  ratios exceeding approximately 30 and stiffened compression elements that have  $w/t$  ratios exceeding approximately 250 are likely to develop noticeable deformation at the full design strength, without affecting the ability of the member to develop required strength.

Stiffened elements having  $w/t$  ratios larger than 500 can be used with adequate design strength to sustain the required loads; however, substantial deformations of such elements usually will invalidate the design formulas of this Specification.

(b) *Flange Curling*

Where the flange of a flexural member is unusually wide and it is desired to limit the maximum amount of curling or movement of the flange toward the neutral axis, the following formula applies to compression and tension flanges, either stiffened or unstiffened:

$$w_f = \sqrt{0.061tdE/F_{av}} \sqrt{100c_f/d} \quad (\text{Eq. B.1.1-1})$$

For SI:  $\times 25.4$  for mm

**WHERE:**

$w_f$  = Width of flange projecting beyond the web; or half of the distance between webs for box- or U-type beams

$t$  = Flange thickness

$d$  = Depth of beam

$c_f$  = Amount of curling [The amount of curling that can be tolerated will vary with different kinds of sections and shall be established by the designer. The amount of curling in the order of 5 percent of the depth of the section is usually not considered excessive.]

$f_{av}$  = Average stress in the full, unreduced flange width. (Where members are designed by the effective design width procedure, the average stress equals the maximum stress multiplied by the ratio of the effective design width to the actual width.)

(c) *Shear Lag Effects—Short Spans Supporting Concentrated Loads*

Where the span of the beam is less than  $30w_f$  ( $w_f$  as defined below) and it carries one concentrated load, or several loads spaced farther apart than  $2w_f$ , the effective design width of any flange, whether in tension or compression, shall be limited to the following:

**TABLE B1.1 (C)**  
**SHORT, WIDE FLANGES MAXIMUM ALLOWABLE RATIO OF EFFECTIVE**  
**DESIGN WIDTH TO ACTUAL WIDTH**

$L/w_f$	Ratio	$L/w_f$	Ratio
30	1.00	14	0.82
25	0.96	12	0.78
20	0.91	10	0.73
18	0.89	8	0.67
16	0.86	6	0.55

**WHERE:**

$L$  = Full span for simple beams; or the distance between inflection points for continuous beams; or twice the length of cantilever beams.

$w_f$  = Width of flange projection beyond the web for I-beam and similar sections or half the distance between webs of box or U-type sections.

For flanges of I-beams and similar sections stiffened by lips at the outer edges,  $w_f$  shall be taken as the sum of the flange projection beyond the web plus the depth of the lip.

**B1.2 Maximum Web Depth-to-Thickness Ratio.** The ratio,  $h/t$ , of the webs of flexural members shall not exceed the following limitations:

- (a) For unreinforced webs:  $(h/t)_{\max} = 200$
- (b) For webs which are provided with transverse stiffeners satisfying the requirements of Section B6.1:
  - (1) When using bearing stiffeners only,  $(h/t)_{\max} = 260$
  - (2) When using bearing stiffeners and intermediate stiffeners,  $(h/t)_{\max} = 300$

In the above,

$h$  = Depth of flat portion of web measured along the plane of web  
 $t$  = Web thickness

Where a web consists of two or more sheets, the  $h/t$  ratio shall be computed for the individual sheets.

**B2 Effective Widths of Stiffened Elements B2.1 Uniformly Compressed Stiffened Elements (a) Load Capacity Determination**

The effective widths,  $b$ , of uniformly compressed elements shall be determined from the following formulas:

$$b = w \text{ when } \lambda \leq 0.673 \quad (\text{Eq. B2.1-1})$$

$$b = \rho w \text{ when } \lambda > 0.673 \quad (\text{Eq. B2.1-2})$$

**WHERE:**

$w$  = Flat width as shown in Figure B2.1-1

$$\rho = (1 - 0.22/\lambda) / \lambda \quad (\text{Eq. B2.1-3})$$

$\lambda$  is a slenderness factor determined as follows:

$$\lambda = (1.052 / \sqrt{K}) (w/t) (\sqrt{f/E}) \quad (\text{Eq. B2.1-4})$$

**WHERE:**

$t$  = Thickness of the uniformly compressed stiffened elements, and  
 $f$  for load capacity determination is as follows:

For flexural members:

- (1) If Procedure I of Section C3.1.1 is used,  $f = F_y$  if the initial yielding is in compression in the element considered. If the initial yielding is in tension, the compressive stress,  $f$ , in the element considered shall be determined on the basis of the effective section at  $M_y$  (moment causing initial yield).

- (2) If Procedure II of Section C3.1.1 is used then  $f$  is the stress in the element considered at  $M_n$  determined on the basis of the effective section.
- (3) If Section C3.1.2 is used, then  $f$  is  $M_c/S_f$  as described in that Section in determining  $S_c$ . For compression members  $f$  is taken equal to  $F_n$  as determined in Section C4 or D4.1 as applicable.

$E$  = Modulus of elasticity

$k$  = Plate buckling coefficient

= 4 for stiffened elements supported by a web on each longitudinal edge. Values for different types of elements are given in the applicable sections.

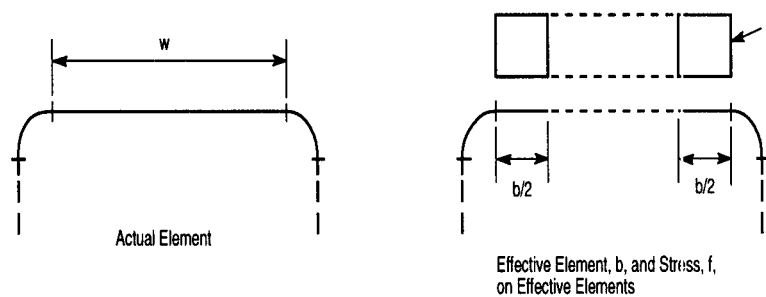

Figure B2.1-1 Stiffened Elements

- (b) *Deflection Determination.* The effective widths,  $b_d$ , used in computing deflection shall be determined from the following formulas:

$$b_d = w \text{ when } \lambda \leq 0.673 \quad (\text{Eq. B2.1-5})$$

$$b_d = \rho w \text{ when } \lambda > 0.673 \quad (\text{Eq. B2.1-6})$$

**WHERE:**

$w$  = Flat width

$\rho$  = Reduction factor determined by either of the following two procedures:

- (1) Procedure I.

A low estimate of the effective width may be obtained from Eqs. B2.1-3 and B2.1-4 where  $f_d$  is substituted for  $f$  where  $f_d$  is the computed compressive stress in the element being considered.

- (2) Procedure II.

For stiffened elements supported by a web on each longitudinal edge an improved estimate of the effective width can be obtained by calculating  $\rho$  as follows:

$$\rho = 1 \text{ when } \lambda \leq 0.673 \quad (\text{Eq. B2.1-7})$$

$$\rho = (1.358 - 0.461/\lambda) / \lambda \text{ when } 0.673 < \lambda < \lambda_c \quad (\text{Eq. B2.1-8})$$

$$\rho = (0.41 + 0.59 \sqrt{F_y/f_d} - 0.22/\lambda) / \lambda \text{ when } \lambda \geq \lambda_c \quad (\text{Eq. B2.1-9})$$

$\rho$  shall not exceed 1.0 for all cases.

**WHERE:**

$$\lambda_c = 0.256 + 0.328 (w/t) \sqrt{F_y/E} \quad (\text{Eq. B2.1-10})$$

and  $\lambda$  is as defined by Eq. B2.1-4 except that  $f_d$  is substituted for  $f$ .

**B2.2 Uniformly Compressed Stiffened Elements with Circular Holes.** (a) *Load Capacity Determination.* The effective width,  $b$ , of stiffened elements with uniform compression having circular holes shall be determined as follows:

for  $0.50 \geq d_h/w \geq 0$ , and  $w/t \leq 70$   
center-to-center spacing of holes  $> 0.50w$ , and  $3d_h$ ,

$$b = w - d_h \text{ when } \lambda \leq 0.673 \quad (\text{Eq. B2.2-1})$$

$$b = w(1 - 0.22/\lambda - 0.8d_h/w)/\lambda \text{ when } \lambda > 0.673 \quad (\text{Eq. B2.2-2})$$

b shall not exceed  $w - d_h$

**WHERE:**

w = Flat width

$d_h$  = Diameter of holes

$\lambda$  is as defined in Section B2.1.

(b) *Deflection Determination.* The effective width,  $b_d$ , used in deflection calculations shall be equal to b determined in accordance with Procedure I of Section B2.2a except that  $f_d$  is substituted for f, where  $f_d$  is the computed compressive stress in the element being considered.

**B2.3 Effective Widths of Webs and Stiffened Elements with Stress Gradient.** (a) *Load Capacity Determination.* The effective widths,  $b_1$  and  $b_2$ , as shown in Figure B2.3-1 shall be determined from the following formulas:

$$b_1 = b_e/(3 - \psi) \quad (\text{Eq. B2.3-1})$$

For  $\psi \leq -0.236$

$$b_2 = b_e/2 \quad (\text{Eq. B2.3-2})$$

$b_1 + b_2$  shall not exceed the compression portion of the web calculated on the basis of effective section

For  $\psi > -0.236$

$$b_2 = b_e - b_1 \quad (\text{Eq. B2.3-3})$$

**WHERE:**

$b_e$  = Effective width b determined in accordance with Section B2.1 with  $f_1$  substituted for f and with k determined as follows:

$$k = 4 + 2(1 - \psi)^3 + 2(1 - \psi) \quad (\text{Eq. B2.3-4})$$

$$\psi = f_2/f_1$$

$f_1, f_2$  = Stresses shown in Figure B2.3-1 calculated on the basis of effective section.

$f_1$  is compression (+) and  $f_2$  can be either tension (-) or compression. In case  $f_1$  and  $f_2$  are both compression,  $f_1 \geq f_2$

(b) *Deflection Determination.* The effective widths in computing deflections at a given load shall be determined in accordance with Section B2.3a except that  $f_{d1}$  and  $f_{d2}$  are substituted for  $f_1$  and  $f_2$ , where  $f_{d1}, f_{d2}$  = Computed stresses  $f_1$  and  $f_2$  as shown in Figure B2.3-1. Calculations are based on the effective section at the load for which deflections are determined.

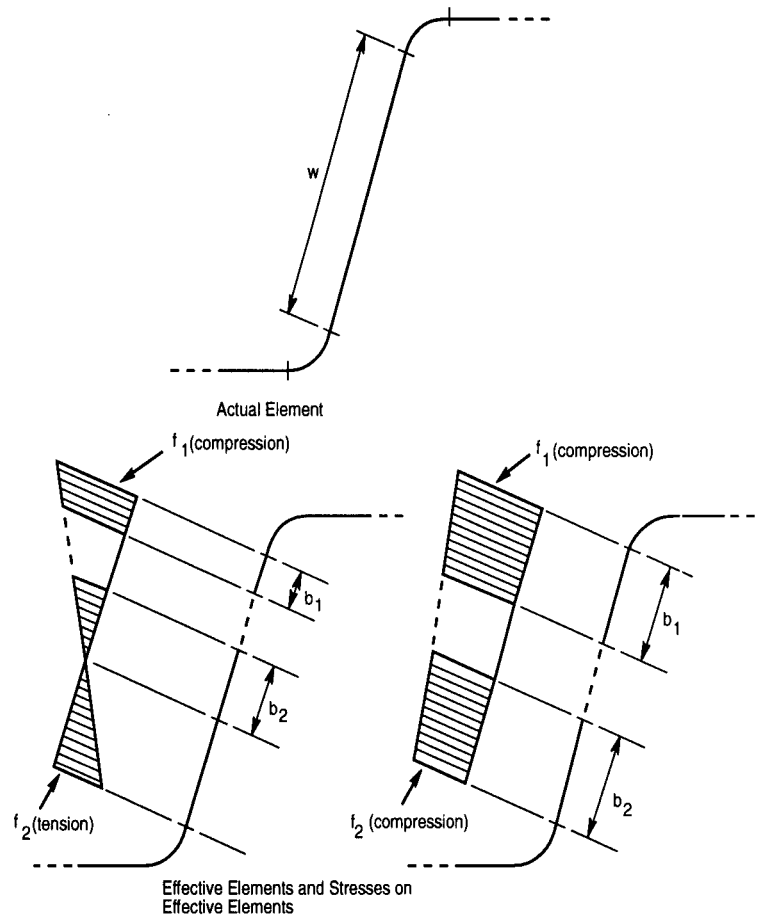

**Figure B2.3-1 Stiffened Elements with Stress Gradient and Webs**

B3 Effective Widths of Unstiffened Elements. B3.1 Uniformly Compressed Unstiffened Elements. (a) *Load Capacity Determination*. Effective widths,  $b$ , of unstiffened compression elements with uniform compression shall be determined in accordance with Section B2.1a with the exception that  $k$  shall be taken as 0.43 and  $w$  as defined in Figure B3.1-1.

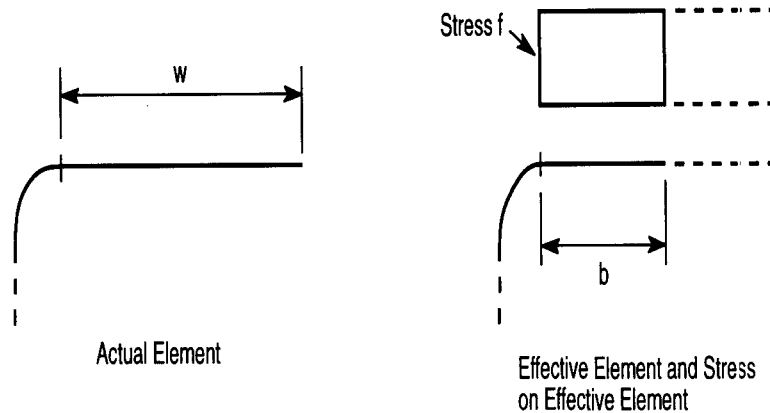

**Figure B3.1-1 Unstiffened Element with Uniform Compression**

(b) *Deflection Determination.* The effective widths used in computing deflections shall be determined in accordance with Procedure I of Section B2.1b except that  $f_d$  is substituted for  $f$  and  $k = 0.43$ .

B3.2 Unstiffened Elements and Edge Stiffeners with Stress Gradient. (a) *Load Capacity Determination.* Effective widths,  $b$ , of unstiffened compression elements and edge stiffeners with stress gradient shall be determined in accordance with Section B2.1a with  $f = f_3$  as in Figure B4-2 in the element and  $k = 0.43$ .

(b) *Deflection Determination.* Effective widths,  $b$ , of unstiffened compression elements and edge stiffeners with stress gradient shall be determined in accordance with Procedure I of Section B2.1b except that  $f_{d3}$  is substituted for  $f$  and  $k = 0.43$ .

B4 Effective Widths of Elements with an Edge Stiffener or One Intermediate Stiffener. The following notation is used in this section.

$$S = 1.28 \sqrt{E/F} \quad (\text{Eq. B4-1})$$

$k$  = Buckling coefficient

$b_o$  = Dimension defined in Figure B4-1

$d, w, D$  = Dimensions defined in Figure B4-2

$d_s$  = Reduced effective width of the stiffener as specified in this section.  $d_s$ , calculated according to Section B4.2, is to be used in computing the overall effective section properties (see Figure B4-2)

$d'_s$  = Effective width of the stiffener calculated according to Section B3.1 (see Figure B4-2)

$C_1, C_2$  = Coefficients defined in Figure B4-2

$A_s$  = Reduced area of the stiffener as specified in this section.  $A_s$  is to be used in computing the overall effective section properties. The centroid of the stiffener is to be considered located at the centroid of the full area of the stiffener, and the moment of inertia of the stiffener about its own centroidal axis shall be that of the full section of the stiffener.

$I_a$  = Adequate moment of inertia of stiffener, so that each component element will behave as a stiffened element.

$I_s, A'_s$  = Moment of inertia of the full stiffener about its own centroidal axis parallel to the element to be stiffened and the effective area of the stiffener, respectively. For edge stiffeners the round corner between the stiffener and the element to be stiffened shall not be considered as a part of the stiffener.

For the stiffener shown in Figure B4-2:

$$I_s = (d^3 t \sin^2 \theta) / 12 \quad (\text{Eq. B4-2})$$

$$A'_s = d'_s t \quad (\text{Eq. B4-3})$$

**B4.1 Uniformly Compressed Elements with an Intermediate Stiffener (a) Load Capacity Determination**

Case I:  $b_o/t \leq S$  (Eq. B4.1-1)

$$I_a = 0 \text{ (no intermediate stiffener needed)} \quad (\text{Eq. B4.1-2})$$

$$b = w \quad (\text{Eq. B4.1-3})$$

$$A_s = A'_s \quad (\text{Eq. B4.1-4})$$

Case II:  $S < b_o/t < 3S$  (Eq. B4.1-5)

$$I_a/t^4 = [50(b_o/t)/S] - 50 \quad (\text{Eq. B4.1-6})$$

$b$  and  $A_s$  are calculated according to Section B2.1a where

$$k = 3(I_s/I_a)^{1/2} + 1 \leq 4 \quad (\text{Eq. B4.1-7})$$

$$A_s = A'_s (I_s/I_a) \leq A'_s \quad (\text{Eq. B4.1-8})$$

Case III:  $b_o/t \geq 3S$

$$I_a/t^4 = [128(b_o/t)/S] - 285 \quad (\text{Eq. B4.1-9})$$

$b$  and  $A_s$  are calculated according to Section B2.1a where

$$k = 3(I_s/I_a)^{1/3} + 1 \leq 4 \quad (\text{Eq. B4.1-10})$$

$$A_s = A'_s (I_s/I_a) \leq A'_s \quad (\text{Eq. B4.1-11})$$

(b) *Deflection Determination.* Effective widths shall be determined as in Section B4.1a except that  $f_d$  is substituted for  $f$ .

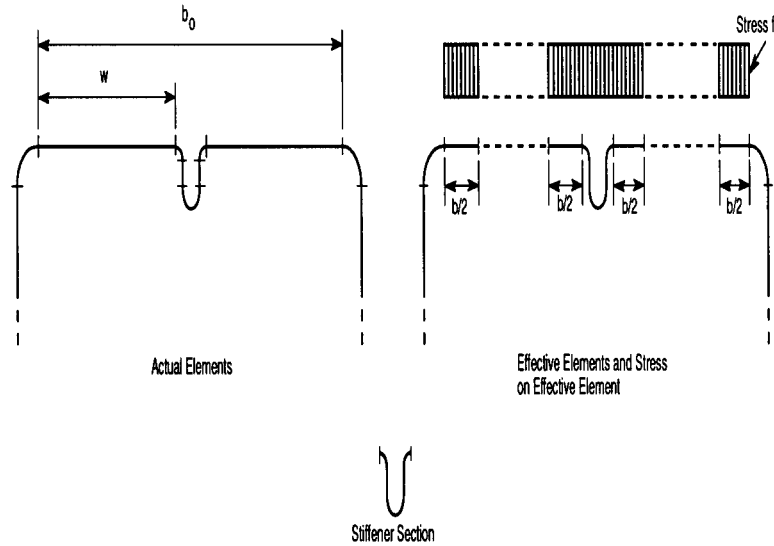

**Figure B4-1 Elements with Intermediate Stiffener**

**B4.2 Uniformly Compressed Elements with an Edge Stiffener. (a) Load Capacity Determination.**

Case I:  $w/t \leq S/3$  (Eq. B4.2-1)

$$I_a = 0 \text{ (no edge stiffener needed)} \quad (\text{Eq. B4.2-2})$$

$$b = w \quad (\text{Eq. B4.2-3})$$

$$d_s = d'_s \text{ for simple lip stiffener} \quad (\text{Eq. B4.2-4})$$

$$A_s = A'_s \text{ for other stiffener shapes} \quad (\text{Eq. B4.2-5})$$

Case II:  $S/3 < w/t < S$

$$I_a/t^4 = 399 \{ [(w/t)/S] - 0.33 \}^3 \quad (\text{Eq. B4.2-6})$$

$$n = 1/2$$

$$C_2 = I_s/I_a \leq 1 \quad (\text{Eq. B4.2-7})$$

$$C_1 = 2 - C_2 \quad (\text{Eq. B4.2-8})$$

b shall be calculated according to Section B2.1 where

$$k = [4.82 - 5(D/w)](I_s/I_a)^n + 0.43 \leq 5.25 - 5(D/w) \quad (\text{Eq. B4.2-9})$$

for  $0.8 \geq D/w > 0.25$

$$k = 3.57(I_s/I_a)^n + 0.43 \leq 4.0 \quad (\text{Eq. B4.2-10})$$

for  $(D/w) \leq 0.25$

$$d_s = d'_s (I_s/I_a) \leq d'_s \quad (\text{Eq. B4.2-11})$$

for simple lip stiffener

$$A_s = A'_s (I_s/I_a) \leq A'_s \quad (\text{Eq. B4.2-12})$$

for other stiffener shape

Case III:  $w/t \geq S$

$$I_a/t^4 = [115 (w/t)/S] + 5 \quad (\text{Eq. B4.2-13})$$

$C_1, C_2, b, k, d_s, A_s$  are calculated per Case II with  $n = 1/3$ .

(b) *Deflection Determination.* Effective widths shall be determined as in Section B4.2a except that  $f_d$  is substituted for  $f$ .

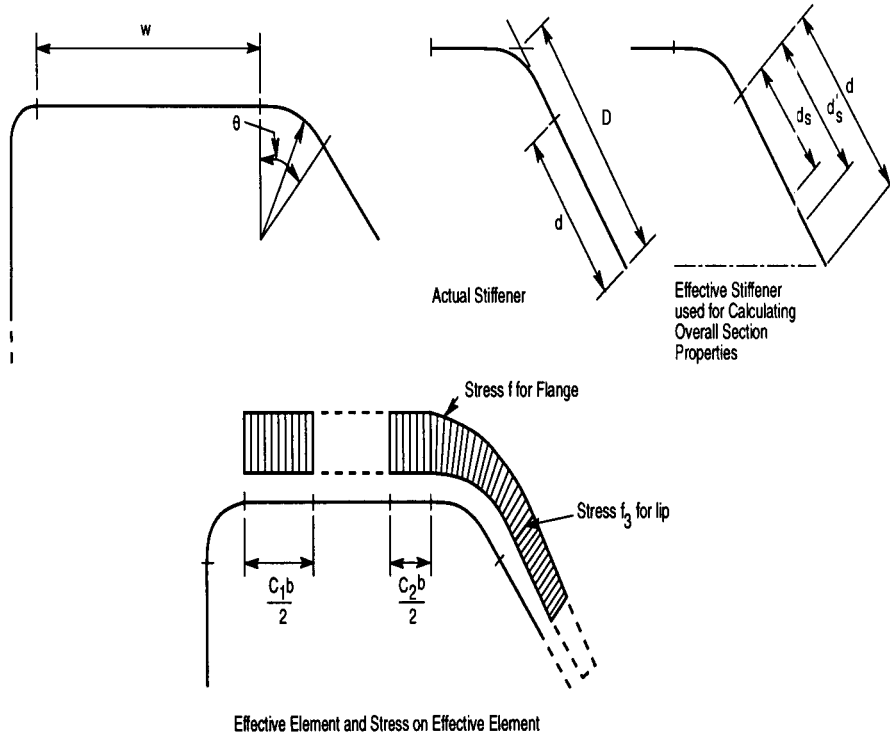

Figure B4-2 Elements with Edge Stiffener

**B5 Effective Widths of Edge Stiffened Elements with Intermediate Stiffeners or Stiffened Elements with More Than One Intermediate Stiffener.** For the determination of the effective width, the intermediate stiffener of an edge stiffened element or the stiffeners of a stiffened element with more than one stiffener shall be disregarded unless each intermediate stiffener has the minimum  $I_s$  as follows:

$$I_{\min} = [3.66 \sqrt{(w/t)^2 - (0.136E/F_y)}]t^4 \quad (\text{Eq. B5-1})$$

but not less than  $18.4 t^4$

**WHERE:**

$w/t$  = Width-thickness ratio of the larger stiffened sub-element

$I_s$  = Moment of inertia of the full stiffener about its own centroidal axis parallel to the element to be stiffened

- (a) If the spacing of intermediate stiffeners between two webs is such that for the sub-element between stiffeners  $b < w$  as determined in Section B2.1, only two intermediate stiffeners (those nearest each web) shall be considered effective.
- (b) If the spacing of intermediate stiffeners between a web and an edge stiffener is such that for the sub-element between stiffeners  $b < w$  as determined in Section B2.1, only one intermediate stiffener, that nearest the web, shall be considered effective.
- (c) If intermediate stiffeners are spaced so closely that for the elements between stiffeners  $b = w$  as determined in Section B2.1, all the stiffeners may be considered effective. In computing the flat-width to thickness ratio of the entire multiple-stiffened element, such element shall be considered as replaced by an "equivalent element" without intermediate stiffeners whose width,  $b_o$ , is the full width between webs or from web to edge stiffener, and whose equivalent thickness,  $t_s$ , is determined as follows:

$$t_s = \sqrt[3]{12I_{st}/b_o} \quad (\text{Eq. B5-2})$$

**WHERE:**

$I_{st}$  = Moment of inertia of the full area of the multiple-stiffened element, including the intermediate stiffeners, about its own centroidal axis. The moment of inertia of the entire section shall be calculated assuming the "equivalent element" to be located at the centroidal axis of the multiple stiffened element, including the intermediate stiffener. The actual extreme fiber distance shall be used in computing the section modulus.

- (d) If  $w/t > 60$ , the effective width,  $b_e$ , of the sub-element or element shall be determined from the following formula:

$$b_e/t = b/t - 0.10(w/t - 60) \quad (\text{Eq. B5-3})$$

**WHERE:**

$w/t$  = flat-width ratio of sub-element or element

$b$  = effective design width determined in accordance with the provisions of Section B2.1

$b_e$  = effective design width of sub-element or element to be used in design computations

For computing the effective structural properties of a member having compression sub-elements or element subject to the above reduction in effective width, the area of stiffeners (edge stiffener or intermediate stiffeners) shall be considered reduced to an effective area as follows:

For  $60 < w/t < 90$ :

$$A_{ef} = \alpha A_{st} \quad (\text{Eq. B5-4})$$

**WHERE:**

$$\alpha = (3 - 2b_e/w) - (1/30)(1 - b_e/w)(w/t) \quad (\text{Eq. B5-5})$$

For  $w/t \geq 90$ :

$$A_{ef} = (b_c/w) A_{st} \quad (Eq. B5-6)$$

In the above expressions,  $A_{ef}$  and  $A_{st}$  refer only to the area of the stiffener section, exclusive of any portion of adjacent elements.

The centroid of the stiffener is to be considered located at the centroid of the full area of the stiffener, and the moment of inertia of the stiffener about its own centroidal axis shall be that of the full section of the stiffener.

**B6 Stiffeners. B6.1 Transverse Stiffeners.** Transverse stiffeners attached to beam webs at points of concentrated loads or reactions, shall be designed as compression members. Concentrated loads or reactions shall be applied directly into the stiffeners, or each stiffener shall be fitted accurately to the flat portion of the flange to provide direct load bearing into the end of the stiffener. Means for shear transfer between the stiffener and the web shall be provided according to Chapter E. Required strengths for the concentrated loads or reactions shall not exceed the design strength,  $\phi_c P_n$ , where  $\phi_c = 0.85$  and  $P_n$  is the smaller value given by (a) and (b) as follows:

$$(a) P_n = F_{wy} A_c \quad (Eq. B6.1-1)$$

$$(b) P_n = \text{Nominal axial strength evaluated according to Section C4(a) with } A_c \text{ replaced by } A_b$$

**WHERE:**

$$A_c = 18t^2 + A_s, \text{ for transverse stiffeners at interior support and under concentrated load} \quad (Eq. B6.1-2)$$

$$A_c = 10t^2 + A_s, \text{ for transverse stiffeners at end support} \quad (Eq. B6.1-3)$$

$$F_{wy} = \text{Lower value of beam web, } F_y \text{ or stiffener section, } F_{ys}$$

$$A_b = b_1 t + A_s, \text{ for transverse stiffeners at interior support and under concentrated load} \quad (Eq. B6.1-4)$$

$$A_b = b_2 t + A_s, \text{ for transverse stiffeners at end support} \quad (Eq. B6.1-5)$$

$$A_s = \text{Cross sectional area of transverse stiffeners}$$

$$b_1 = 25t [0.0024(L_{st}/t) + 0.72] \leq 25t \quad (Eq. B6.1-6)$$

$$b_2 = 12t [0.0044(L_{st}/t) + 0.83] \leq 12t \quad (Eq. B6.1-7)$$

$$L_{st} = \text{Length of transverse stiffener}$$

$$t = \text{Base thickness of beam web}$$

The  $w/t_s$  ratio for the stiffened and unstiffened elements of cold-formed steel transverse stiffeners shall not exceed  $1.28 \sqrt{(E/F_{ys})}$  and  $0.37 \sqrt{(E/F_{ys})}$ , respectively, where  $F_{ys}$  is the yield stress,  $F_y$ , and  $t_s$  the thickness of the stiffener steel.

**B6.2 Shear Stiffeners.** Where shear stiffeners are required, the spacing shall be such that the required shear strength shall not exceed the design shear strength,  $\phi_v V_n$ , permitted by Section C3.2, and the ratio  $a/h$  shall not exceed  $[260/(h/t)]^2$  nor 3.0.

The actual moment of inertia,  $I_s$ , of a pair of attached shear stiffeners, or of a single shear stiffener, with reference to an axis in the plane of the web, shall have a minimum value of

$$I_{smin} = 5ht^3[h/a - 0.7(a/h)] \geq (h/50)^4 \quad (Eq. B6.2-1)$$

The gross area of shear stiffeners shall be not less than

$$A_{st} = [(1 - C_v)/2] \left\{ a/h - (a/h)^2 / [(a/h) + \sqrt{1 + (a/h)^2}] \right\} YDht \quad (Eq. B6.2-2)$$

**WHERE:**

$$C_v = 45,000k_v / [F_y (h/t)^2] \quad (\text{For SI: } C_v = 1.55 k_v E / [F_y (h/t)^2]) \text{ when } C_v \leq 0.8 \quad (Eq. B6.2-3)$$

$$C_v = [190/(h/t)] \sqrt{k_v/F_y} \quad (\text{For SI: } [1.12/(h/t)] \sqrt{E k_v/F_y}) \text{ when } C_v > 0.8 \quad (Eq. B6.2-4)$$

$$k_v = 4.00 + 5.34 / (a/h)^2 \quad \text{when } a/h \leq 1.0 \quad (Eq. B6.2-5)$$

$$k_v = 5.34 + 4.00 / (a/h)^2 \quad \text{when } a/h > 1.0 \quad (\text{Eq. B6.2-6})$$

- $a$  = Distance between transverse stiffeners  
 $Y$  = Yield point of web steel/Yield point of stiffener steel  
 $D$  = 1.0 for stiffeners furnished in pairs  
 $D$  = 1.8 for single-angle stiffeners  
 $D$  = 2.4 for single-plate stiffeners  
 $t$  and  $h$  are as defined in Section B1.2

**B6.3 Non-Conforming Stiffeners.** The design strength of members with transverse stiffeners that do not meet the requirements of Section B6.1 or B6.2, such as stamped or rolled-in transverse stiffeners shall be determined by tests in accordance with Chapter F of this Specification.

### C. MEMBERS

**C1 Properties of Sections.** Properties of sections (cross-sectional area, moment of inertia, section modulus, radius of gyration, etc.) shall be determined in accordance with conventional methods of structural design. Properties shall be based on the full cross section of the members (or net sections where the use of net section is applicable) except where the use of a reduced cross section, or effective design width, is required.

**C2 Tension Members.** For axially loaded tension members, the design tensile strength,  $\phi_t T_n$ , shall be determined as follows:

$$\phi_t = 0.95$$

$$T_n = A_n F_y \quad (\text{Eq. C2-1})$$

**WHERE:**

- $T_n$  = Nominal strength of member when loaded in tension  
 $\phi_t$  = Resistance factor for tension  
 $A_n$  = Net area of the cross section  
 $F_y$  = Design yield stress as determined in Section A5.2.1

For tension members using bolted connections, the design tensile strength shall also be limited by Section E3.2.

**C3 Flexural Members.** **C3.1 Strength for Bending Only.** The design flexural strength,  $\phi_b M_n$ , shall be the smallest of the values calculated according to Sections C3.1.1, C3.1.2, and C3.1.3.

**C3.1.1 Nominal Section Strength.** The design flexural strength,  $\phi_b M_n$ , shall be determined with  $\phi_b = 0.95$  for sections with stiffened or partially stiffened compression flanges and 0.90 for sections with unstiffened compression flanges, and the nominal section strength,  $M_n$ , calculated either on the basis of initiation of yielding in the effective section (Procedure I) or on the basis of the inelastic reserve capacity (Procedure II) as applicable.

(a) Procedure I—Based on Initiation of Yielding. Effective yield moment based on section strength,  $M_n$ , shall be determined as follows:

$$M_n = S_e F_y \quad (\text{Eq. C3.1.1-1})$$

**WHERE:**

- $F_y$  = Design yield stress as determined in Section A5.2.1  
 $S_e$  = Elastic section modulus of the effective section calculated with the extreme compression or tension fiber at  $F_y$

(b) Procedure II—Based on Inelastic Reserve Capacity. The inelastic flexural reserve capacity may be used when the following conditions are met:

- (1) The member is not subject to twisting or to lateral, torsional, or torsional-flexural buckling.
- (2) The effect of cold forming is not included in determining the yield point  $F_y$ .

- (3) The ratio of the depth of the compressed portion of the web to its thickness does not exceed  $\lambda_1$ .
- (4) The shear force does not exceed  $0.35F_y$  times the web area,  $ht$ .
- (5) The angle between any web and the vertical does not exceed 30 degrees.

The nominal flexural strength,  $M_n$ , shall not exceed either  $1.25 S_e F_y$  determined according to Procedure I or that causing a maximum compression strain of  $C_y e_y$  (no limit is placed on the maximum tensile strain).

**WHERE:**

- $e_y$  = Yield strain =  $F_y/E$   
 $E$  = Modulus of elasticity  
 $C_y$  = Compression strain factor determined as follows:

- (a) Stiffened compression elements without intermediate stiffeners

$$C_y = 3 \text{ for } w/t \leq \lambda_1$$

$$C_y = 3 - 2[(w/t) - \lambda_1]/(\lambda_2 - \lambda_1) \text{ for } \lambda_1 < w/t < \lambda_2$$

$$C_y = 1 \text{ for } w/t \geq \lambda_2$$

**WHERE:**

$$\lambda_1 = 1.11/\sqrt{F_y/E} \quad (\text{Eq. C3.1.1-2})$$

$$\lambda_2 = 1.28/\sqrt{F_y/E} \quad (\text{Eq. C3.1.1-2})$$

- (b) Unstiffened compression elements

$$C_y = 1$$

- (c) Multiple-stiffened compression elements and compression elements with edge stiffeners

$$C_y = 1$$

When applicable, effective design widths shall be used in calculating section properties.  $M_n$  shall be calculated considering equilibrium of stresses, assuming an ideally elastic-plastic stress-strain curve which is the same in tension as in compression, assuming small deformation and assuming that plane sections remain plane during bending. Combined bending and web crippling shall be checked by provisions of Section C3.5.

**C3.1.2 Lateral Buckling Strength.** [The provisions of this Section apply to I-, Z-, C- and other singly-symmetric section flexural members (not including multiple-web deck, U- and closed box-type members, and curved or arch members). The provisions of this Section do not apply to laterally unbraced compression flanges of otherwise laterally stable sections. Refer to C3.1.3 for C- and Z-purlins in which the tension flange is attached to sheathing.

The design strength of the laterally unbraced segments of singly-, doubly-, and point-symmetric sections subject to lateral buckling,  $\phi_b M_n$  shall be determined with  $\phi_b = 0.90$  and  $M_n$  calculated as follows:

$$M_n = S_c(M_c/S_f) \quad (\text{Eq. C3.1.2-1})$$

**WHERE:**

$S_f$  = Elastic section modulus of the full unreduced section for the extreme compression fiber

$S_c$  = Elastic section modulus of the effective section calculated at a stress  $M_c / S_f$  in the extreme compression fiber

$M_c$  = Critical moment calculated according to (a) or (b) below:

- (a) For singly-, doubly-, and point-symmetric sections:

For  $M_e > 0.5M_y$

$$M_c = M_y(1 - M_y/4M_e) \quad (\text{Eq. C3.1.2-2})$$

For  $M_e \leq 0.5M_y$

$$M_c = M_e \quad (\text{Eq. C3.1.2-3})$$

**WHERE:**

$$M_y = \text{Moment causing initial yield at the extreme compression fiber of the full section} \\ = S_f F_y \quad (\text{Eq. C3.1.2-4})$$

$M_e$  = Elastic critical moment computed by the following equations:

$$M_e = C_b r_o A \sqrt{\sigma_{ey} \sigma_t} \text{ for bending about the symmetry axis. For singly-symmetric sections, x-axis} \\ \text{is the axis of symmetry oriented such that the shear center has a negative x-coordinate. For} \\ \text{point-symmetric sections, use } 0.5 M_e. \quad (\text{Eq. C3.1.2-5})$$

Alternatively,  $M_e$  can be calculated using the formula for doubly-symmetric I-sections or point-symmetric sections given in (b)

$$M_e = C_s A \sigma_{ex} [j + C_s \sqrt{j^2 + r_o^2 (\sigma_t / \sigma_{ex})}] / C_{TF} \quad (\text{Eq. C3.1.2-6}) \\ \text{for bending about the centroidal axis perpendicular to the symmetry axis for singly-sym-} \\ \text{metric sections only}$$

$C_s$  = +1 for moment causing compression on the shear center side of the centroid

$C_s$  = -1 for moment causing tension on the shear center side of the centroid

$$\sigma_{ex} = \pi^2 E / (K_x L_x / r_x)^2 \quad (\text{Eq. C3.1.2-7})$$

$$\sigma_{ey} = \pi^2 E / (K_y L_y / r_y)^2 \quad (\text{Eq. C3.1.2-8})$$

$$\sigma_t = [1 / (A r_o^2)] [GJ + \pi^2 E C_w / (K_t L_t)^2] \quad (\text{Eq. C3.1.2-9})$$

$A$  = Full cross-sectional area

$C_b$  = Bending coefficient which can conservatively be taken as unity, or calculated from

$$C_b = 1.75 + 1.05(M_1/M_2) + 0.3 (M_1/M_2)^2 \leq 2.3$$

**WHERE:**

$M_1$  is the smaller and  $M_2$  the larger bending moment at the ends of the unbraced length, taken about the strong axis of the member, and where  $M_1/M_2$ , the ratio of end moments, is positive when  $M_1$  and  $M_2$  have the same sign (reverse curvature bending) and negative when they are of opposite sign (single curvature bending). When the bending moment at any point within an unbraced length is larger than that at both ends of this length, and for members subject to combined axial load and bending moment (Section C5),  $C_b$  shall be taken as unity.

$E$  = Modulus of elasticity

$$C_{TF} = 0.6 - 0.4 (M_1/M_2)$$

**WHERE:**

$M_1$  is the smaller and  $M_2$  the larger bending moment at the ends of the unbraced length, and where  $M_1/M_2$ , the ratio of end moments, is positive when  $M_1$  and  $M_2$  have the same sign (reverse curvature bending) and negative when they are of opposite sign (single curvature bending). When the bending moment at any point within an unbraced length is larger than that at both ends of this length, and for members subject to combined axial load and bending moment (Section C5),  $C_{TF}$  shall be taken as unity.

$r_o$  = Polar radius of gyration of the cross section about the shear center

$$= \sqrt{r_x^2 + r_y^2 + x_o^2} \quad (\text{Eq. C3.1.2-10})$$

$r_x, r_y$  = Radii of gyration of the cross section about the centroidal principal axes

$G$  = Shear modulus

$K_x, K_y, K_t$  = Effective length factors for bending about the x- and y-axes, and for twisting

$L_x, L_y, L_t$  = Unbraced length of compression member for bending about the x- and y-axes, and for twisting

$x_o$  = Distance from the shear center to the centroid along the principal x-axis, taken as negative

$J$  = St. Venant torsion constant of the cross section

$C_w$  = Torsional warping constant of the cross section

$$j = [1 / (2I_y)] (\int A x^3 dA + \int A x y^2 dA) - x_o \quad (\text{Eq. C3.1.2-11})$$

(b) For I- or Z-sections bent about the centroidal axis perpendicular to the web (x-axis):

In lieu of (a), the following equations may be used to evaluate  $M_c$ :

For  $M_e \geq 2.78M_y$

$$M_c = M_y \quad (\text{Eq. C3.1.2-12})$$

For  $2.78M_y > M_e > 0.56M_y$

$$M_c = (10/9)M_y (1 - 10M_y/36M_e) \quad (\text{Eq. C3.1.2-13})$$

For  $M_e \leq 0.56M_y$

$$M_c = M_e \quad (\text{Eq. C3.1.2-14})$$

**WHERE:**

$M_e$  = Elastic critical moment determined either as defined in (a) above or as follows:

$$= \pi^2 E C_b d I_{yc} / (L^2) \text{ for doubly-symmetric I-sections} \quad (\text{Eq. C3.1.2-15})$$

$$= \pi^2 E C_b d I_{yc} / (2L^2) \text{ for point-symmetric Z-sections} \quad (\text{Eq. C3.1.2-16})$$

$d$  = Depth of section

$L$  = Unbraced length of the member

$I_{yc}$  = Moment of inertia of the compression portion of a section about the gravity axis of the entire section parallel to the web, using the full unreduced section

Other terms are defined in (a).

C3.1.3 Beams Having One Flange Through-Fastened to Deck or Sheathing. This section does not apply to a continuous beam for the region between inflection points adjacent to a support, or to a cantilever beam.

The design flexural strength,  $\phi_b M_n$ , of a Channel or Z-section loaded in a plane parallel to the web, with the tension flange attached to deck or sheathing and with the compression flange laterally unbraced shall be determined with  $\phi_b = 0.90$  and the nominal flexural strength,  $M_n$ , calculated as follows:

$$M_n = R S_e F_y \quad (\text{Eq. C3.1.3-1})$$

**WHERE:**

$R$  = 0.40 for simple span C sections

= 0.50 for simple span Z sections

= 0.60 for continuous span C sections

= 0.70 for continuous span Z sections

$S_e$  and  $F_y$  are defined in Section C3.1.1

The reduction factor,  $R$ , shall be limited to roof and wall systems meeting the following conditions:

(1) Member depth less than 11.5 inches (292 mm)

(2) The flanges are edge stiffened compression elements

(3)  $60 \leq \text{depth/thickness} \leq 170$

(4)  $2.8 \leq \text{depth/flange width} \leq 4.5$

(5)  $16 \leq \text{flat width/thickness of flange} \leq 43$

(6) For continuous span systems, the lap length at each interior support in each direction (distance from center of support to end of lap) shall not be less than:

1.5d for Zee sections

3.0d for Channel sections

(7) Member span length no greater than 33 feet (10 058 mm)

(8) For continuous span systems, the longest member span shall not be more than 20% greater than the shortest span

- (9) Both flanges are prevented from moving laterally at the supports
- (10) Roof or wall panels shall be steel sheets, minimum of 0.019 in. (0.48 mm) coated thickness, having a minimum rib depth of 1 in. (25 mm), spaced a maximum of 12 in. (305 mm) on centers and attached in a manner to effectively inhibit relative movement between the panel and purlin flange
- (11) Insulation shall be glass fiber blanket 0 to 6 inches (0 to 152 mm) thick compressed between the member and panel in a manner consistent with the fastener being used
- (12) Fastener type: minimum No. 12 self-drilling or self-tapping sheet metal screws or  $3/16$ -inch (4.8 mm) rivets, washers  $1/2$  inch (13 mm) diameter
- (13) Fasteners shall not be standoff type screws
- (14) Fasteners shall be spaced not greater than 12 in. (305 mm) on centers and placed near the center of the beam flange

If variables fall outside any of the above stated limits, the user must perform full scale tests in accordance with Section F1 of the Specification, or apply another rational analysis procedure. In any case, the user is permitted to perform tests, in accordance with Section F1, as an alternate to the procedure described in this section.

C3.2 Strength for Shear Only. The design shear strength,  $\phi_v V_n$ , at any section shall be calculated as follows:

(a) For  $h/t \leq \sqrt{Ek_v/F_y}$

$$\begin{aligned}\phi_v &= 1.0 \\ V_n &= 0.577F_y h t\end{aligned}\quad (\text{Eq. C3.2-1})$$

(b) For  $\sqrt{Ek_v/F_y} < h/t \leq 1.415\sqrt{Ek_v/F_y}$

$$\begin{aligned}\phi_v &= 0.90 \\ V_n &= 0.64t^2 \sqrt{k_v F_y E}\end{aligned}\quad (\text{Eq. C3.2-2})$$

(c) For  $h/t > 1.415\sqrt{Ek_v/F_y}$

$$\begin{aligned}\phi_v &= 0.90 \\ V_n &= 0.905Ek_v t^3/h\end{aligned}\quad (\text{Eq. C3.2-3})$$

**WHERE:**

- $\phi_v$  = Resistance factor for shear
- $V_n$  = Nominal shear strength of beam
- $t$  = Web thickness
- $h$  = Depth of the flat portion of the web measured along the plane of the web
- $k_v$  = Shear buckling coefficient determined as follows:
  1. For unreinforced webs,  $k_v = 5.34$
  2. For beam webs with transverse stiffeners satisfying the requirements of Section B6

when  $a/h \leq 1.0$

$$k_v = 4.00 + 5.34/(a/h)^2 \quad (\text{Eq. C3.2-4})$$

when  $a/h > 1.0$

$$k_v = 5.34 + 4.00/(a/h)^2 \quad (\text{Eq. C3.2-4})$$

**WHERE:**

- $a$  = the shear panel length for unreinforced web element
- = distance between transverse stiffeners for reinforced web elements.

For a web consisting of two or more sheets, each sheet shall be considered as a separate element carrying its share of the shear force.

C3.3 Strength for Combined Bending and Shear For beams with unreinforced webs, the required flexural strength,  $M_u$ , and the required shear strength,  $V_u$ , shall satisfy the following interaction equation:

$$(M_u/\phi_b M_{nxo}) + (V_u/\phi_v V_n)^2 \leq 1.0 \quad (Eq. C3.3-1)$$

For beams with transverse web stiffeners, the required flexural strength,  $M_u$ , and the required shear strength,  $V_u$ , shall not exceed  $\phi_b M_n$  and  $\phi_v V_n$ , respectively. When  $M_u/(\phi_b M_{nxo}) > 0.5$  and  $V_u/(\phi_v V_n) > 0.7$ , then  $M_u$  and  $V_u$  shall satisfy the following interaction equation:

$$0.6(M_u/\phi_b M_{nxo}) + (V_u/\phi_v V_n) \leq 1.3 \quad (Eq. C3.3-2)$$

In the above:

$\phi_b$  = Resistance factor for bending (See Section C3.1)

$\phi_v$  = Resistance factor for shear (See Section C3.2)

$M_n$  = Nominal flexural strength when bending alone exists

$M_{nxo}$  = Nominal flexural strength about the centroidal x-axis determined in accordance with Section C3.1 excluding the provisions of Section C3.1.2

$V_n$  = Nominal shear strength when shear alone exists

C3.4 Web Crippling Strength. These provisions are applicable to webs of flexural members subject to concentrated loads or reactions, or the components thereof, acting perpendicular to the longitudinal axis of the member, and in the plane of the web under consideration, and causing compressive stresses in the web.

To avoid crippling of unreinforced flat webs of flexural members having a flat width ratio,  $h/t$ , equal to or less than 200, the required strength for the concentrated loads and reactions shall not exceed the values of  $\phi_w P_n$ , with  $\phi_w = 0.75$  and  $0.80$  for single unreinforced webs and I-sections, respectively, and  $P_n$  given in Table C3.4-1. Webs of flexural members for which  $h/t$  is greater than 200 shall be provided with adequate means of transmitting concentrated loads and/or reactions directly into the webs.

The formulas in Table C3.4-1 apply to beams when  $R/t \leq 6$  and to deck when  $R/t \leq 7$ ,  $N/t \leq 210$  and  $N/h \leq 3.5$ .

$P_n$  represents the nominal strength for concentrated load or reaction for one solid web connecting top and bottom flanges. For two or more webs,  $P_n$  shall be computed for each individual web and the results added to obtain the nominal load or reaction for the multiple web.

For built-up I-sections, or similar sections, the distance between the web connector and beam flange shall be kept as small as practical.

TABLE C3.4-1  
 $P_n$

		Shapes Having Single Webs		I-Sections or Similar Sections <sup>(1)</sup>
		Stiffened or Partially Stiffened Flanges	Unstiffened Flanges	Stiffened, Partially Stiffened and Unstiffened Flanges
Opposing Loads Spaced $> 1.5h$ <sup>(2)</sup>	End Reaction <sup>(3)</sup>	Eq. C3.4-1	Eq. C3.4-2	Eq. C3.4-3
	Interior Reaction <sup>(4)</sup>	Eq. C3.4-4	Eq. C3.4-4	Eq. C3.4-5
Opposing Loads Spaced $\leq 1.5h$ <sup>(5)</sup>	End Reaction <sup>(3)</sup>	Eq. C3.4-6	Eq. C3.4-6	Eq. C3.4-7
	Interior Reaction <sup>(4)</sup>	Eq. C3.4-8	Eq. C3.4-8	Eq. C3.4-9

Footnotes and Equation References to Table C3.4-1:

- (1) I-sections made of two channels connected back to back or similar sections which provide a high degree of restraint against rotation of the web (such as I-sections made by welding two angles to a channel).

- (2) At locations of one concentrated load or reaction acting either on the top or bottom flange, when the clear distance between the bearing edges of this and adjacent opposite concentrated loads or reactions is greater than 1.5h.
- (3) For end reactions of beams or concentrated loads on the end of cantilevers when the distance from the edge of the bearing to the end of the beam is less than 1.5h.
- (4) For reactions and concentrated loads when the distance from the edge of bearing to the end of the beam is equal to or greater than 1.5h.
- (5) At locations of two opposite concentrated loads or of a concentrated load and an opposite reaction acting simultaneously on the top and bottom flanges, when the clear distance between their adjacent bearing edges is equal to or less than 1.5h.

Equations for Table C3.4-1:

$$t^2 k C_3 C_4 C_\theta [331 - 0.61(h/t)] [1 + 0.01(N/t)] \quad (\text{Eq. C3.4-1})$$

$$t^2 k C_3 C_4 C_\theta [217 - 0.28(h/t)] [1 + 0.01(N/t)] \quad (\text{Eq. C3.4-2})$$

when  $N/t > 60$ , the factor  $[1 + 0.01(N/t)]$  may be increased to  $[0.71 + 0.015(N/t)]$

$$t^2 F_y C_6 (10 + 1.25 \sqrt{N/t}) \quad (\text{Eq. C3.4-3})$$

$$t^2 k C_1 C_2 C_\theta [538 - 0.74(h/t)] [1 + 0.007(N/t)] \quad (\text{Eq. C3.4-4})$$

When  $N/t > 60$ , the factor  $[1 + 0.007(N/t)]$  may be increased to  $[0.75 + 0.011(N/t)]$

$$t^2 F_y C_5 (0.88 + 0.12m) (15 + 3.25 \sqrt{N/t}) \quad (\text{Eq. C3.4-5})$$

$$t^2 k C_3 C_4 C_\theta [244 - 0.57(h/t)] [1 + 0.01(N/t)] \quad (\text{Eq. C3.4-6})$$

$$t^2 F_y C_8 (0.64 + 0.31m) (10 + 1.25 \sqrt{N/t}) \quad (\text{Eq. C3.4-7})$$

$$t^2 k C_1 C_2 C_\theta [771 - 2.26(h/t)] [1 + 0.0013(N/t)] t^2 F_y C_7 (0.82 + 0.15m) \quad (\text{Eq. C3.4-8})$$

$$t^2 F_y C_7 (0.82 + 0.15m) (15 + 3.25 \sqrt{N/t}) \quad (\text{Eq. C3.4-9})$$

For **SI** in Eq. C3.4-1 through C3.4-9: kips  $\times$  4448 for  $N/\text{mm}^2$ .

In the above-referenced formulas:

$\phi_w$  = Resistance factor for web crippling

$P_n$  = Nominal strength for concentrated load or reaction per web

$$C_1 = (1.22 - 0.22k) \quad (\text{Eq. C3.4-10})$$

$$C_2 = (1.06 - 0.06R/t) \leq 1.0 \quad (\text{Eq. C3.4-11})$$

$$C_3 = (1.33 - 0.33k) \quad (\text{Eq. C3.4-12})$$

$$C_4 = (1.15 - 0.15R/t) \leq 1.0 \text{ but not less than } 0.50 \quad (\text{Eq. C3.4-13})$$

$$C_5 = (1.49 - 0.53k) \geq 0.6 \quad (\text{Eq. C3.4-14})$$

$$C_6 = 1 + (h/t)/750, \text{ when } h/t \leq 150 \quad (\text{Eq. C3.4-15})$$

$$= 1.20, \text{ when } h/t > 150 \quad (\text{Eq. C3.4-16})$$

$$C_7 = 1/k, \text{ when } h/t \leq 66.5 \quad (\text{Eq. C3.4-17})$$

$$= [1.10 - (h/t)/665](1/k), \text{ when } h/t > 66.5 \quad (\text{Eq. C3.4-18})$$

$$C_8 = [0.98 - (h/t)/865](1/k) \quad (\text{Eq. C3.4-19})$$

$$C_\theta = 0.7 + 0.3 (\theta / 90)^2 \quad (\text{Eq. C3.4-20})$$

$F_y$  = Design yield stress of the web, see Section A5.2.1

$h$  = Depth of the flat portion of the web measured along the plane of the web

$$k = F_y/33 \text{ (For SI: } k = F_y/227) \quad (\text{Eq. C3.4-21})$$

$$m = t/0.075 \quad (\text{Eq. C3.4-22})$$

$t$  = Web thickness, inches (mm)

$N$  = Actual length of bearing, inches (mm). For the case of two equal and opposite concentrated loads distributed over unequal bearing lengths, the smaller value of  $N$  shall be taken

R = Inside bend radius

$\theta$  = Angle between the plane of the web and the plane of the bearing surface  $\geq 45^\circ$ , but not more than  $90^\circ$

C3.5 Combined Bending and Web Crippling Strength. Unreinforced flat webs of shapes subjected to a combination of bending and concentrated load or reaction shall be designed to meet the following requirements:

(a) For shapes having single unreinforced webs:

$$1.07(P_u/\phi_w P_n) + (M_u/\phi_b M_{nxo}) \leq 1.42 \quad (\text{Eq. C3.5-1})$$

Exception: At the interior supports of continuous spans, the above formula is not applicable to deck or beams with two or more single webs, provided the compression edges of adjacent webs are laterally supported in the negative moment region by continuous or intermittently connected flange elements, rigid cladding, or lateral bracing, and the spacing between adjacent webs does not exceed 10 inches.

(b) For shapes having multiple unreinforced webs such as I-sections made of two channels connected back-to-back, or similar sections which provide a high degree of restraint against rotation of the web (such as I-sections made by welding two angles to a channel);

$$0.82(P_u/\phi_w P_n) + (M_u/\phi_b M_{nxo}) \leq 1.32 \quad (\text{Eq. C3.5-2})$$

Exception: When  $h/t \leq 2.33/\sqrt{F_y/E}$  and  $\lambda \leq 0.673$ , the nominal concentrated load or reaction strength may be determined by Section C3.4. In the above formulas:

$\phi_b$  = Resistance factor for bending (See Section 3.1)

$\phi_w$  = Resistance factor for web crippling (See Section C3.4)

$P_u$  = Required strength for the concentrated load or reaction in the presence of bending moment

$P_n$  = Nominal strength for concentrated load or reaction in the absence of bending moment determined in accordance with Section C3.4

$M_u$  = Required flexural strength at, or immediately adjacent to, the point of application of the concentrated load or reaction  $P_u$

$M_{nxo}$  = Nominal flexural strength about the centroidal x-axis determined in accordance with Section C3.1 excluding the provisions of Section C3.1.2

w = Flat width of the beam flange which contacts the bearing plate

t = Thickness of the web or flange

$\lambda$  = Slenderness factor given by Section B2.1

C4 Concentrically Loaded Compression Members. This section applies to members in which the resultant of all loads acting on the member is an axial load passing through the centroid of the effective section calculated at the stress,  $F_n$ , defined in this section.

(a) The design axial strength,  $\phi_c P_n$ , shall be calculated as follows:

$$\phi_c = 0.85$$

$$P_n = A_e F_n \quad (\text{Eq. C4-1})$$

where

$A_e$  = Effective area at the stress  $F_n$ . For sections with circular holes,  $A_e$  shall be determined according to Section B2.2a, subject to the limitations of that section. If the number of holes in the effective length region times the hole diameter divided by the effective length does not exceed 0.015,  $A_e$  can be determined ignoring the holes.

$F_n$  is determined as follows:

$$\text{For } F_e > F_y/2 \quad F_n = F_y (1 - F_y/4F_e) \quad (\text{Eq. C4-2})$$

$$\text{For } F_e \leq F_y/2 \quad F_n = F_e \quad (\text{Eq. C4-3})$$

$F_e$  is the least of the elastic flexural, torsional and torsional-flexural buckling stress determined according to Sections C4.1 through C4.3.

(b) For C- and Z-shapes, and single-angle sections with unstiffened flanges,  $P_n$  shall be taken as the smaller of  $P_n$  calculated above and  $P_n$  calculated as follows:

$$P_n = A\pi^2E/[25.7(w/t)^2] \quad (\text{Eq. C4-4})$$

where

- A = Area of the full, unreduced cross section
- w = Flat width of the unstiffened element
- t = Thickness of the unstiffened element

(c) Angle sections shall be designed for the required axial strength,  $P_u$ , acting simultaneously with a moment equal to  $P_uL/1000$  applied about the minor principal axis causing compression in the tips of the angle legs.

(d) The slenderness ratio,  $KL/r$ , of all compression members preferably should not exceed 200, except that during construction only,  $KL/r$  preferably should not exceed 300.

C4.1 Sections Not Subject to Torsional or Torsional-Flexural Buckling. For doubly-symmetric sections, closed cross sections and any other sections which can be shown not to be subject to torsional or torsional-flexural buckling, the elastic flexural buckling stress,  $F_e$ , shall be determined as follows:

$$F_e = \pi^2E/(KL/r)^2 \quad (\text{Eq. C4.1-1})$$

where

- E = Modulus of elasticity
- K = Effective length factor [In frames where lateral stability is provided by diagonal bracing, shear walls, attachment to an adjacent structure having adequate lateral stability, or floor slabs or roof decks secured horizontally by walls or bracing systems parallel to the plane of the frame, and in trusses, the effective length factor, K, for compression members which do not depend upon their own bending stiffness for lateral stability of the frame or truss, shall be taken as unity, unless analysis shows that a smaller value may be used. In a frame which depends upon its own bending stiffness for lateral stability, the effective length, KL, of the compression members shall be determined by a rational method and shall not be less than the actual unbraced length.

L = Unbraced length of member

r = Radius of gyration of the full, unreduced cross section

C4.2 Doubly- or Singly-Symmetric Sections Subject to Torsional or Torsional-Flexural Buckling For sections subject to torsional or torsional-flexural buckling,  $F_e$  shall be taken as the smaller of  $F_e$  calculated according to Section C4.1 and  $F_e$  calculated as follows:

$$F_e = (1/2\beta)[(\sigma_{ex} + \sigma_t) - \sqrt{(\sigma_{ex} + \sigma_t)^2 - 4\beta\sigma_{ex}\sigma_t}] \quad (\text{Eq. C4.2-1})$$

Alternatively, a conservative estimate of  $F_e$  can be obtained using the following equation:

$$F_e = \sigma_t\sigma_{ex}/(\sigma_t + \sigma_{ex}) \quad (\text{Eq. C4.2-2})$$

where  $\sigma_t$  and  $\sigma_{ex}$  are as defined in C3.1.2(a) :

$$\beta = 1 - (x_o/r_o)^2 \quad (\text{Eq. C4.2-3})$$

For singly-symmetric sections, the x-axis is assumed to be the axis of symmetry.

C4.3 Nonsymmetric Sections. For shapes whose cross sections do not have any symmetry, either about an axis or about a point,  $F_e$  shall be determined by rational analysis. Alternatively, compression members composed of such shapes may be tested in accordance with Chapter F.

C5 Combined Axial Load and Bending. The required strengths  $P_u$ ,  $M_{ux}$ , and  $M_{uy}$  shall satisfy the following interaction equations:

$$P_u/\phi_c P_n + C_{mx} M_{ux}/\phi_b M_{nx} \alpha_{nx} + C_{my} M_{uy}/\phi_b M_{ny} \alpha_{ny} \leq 1.0 \quad (\text{Eq. C5-1})$$

$$P_u/\phi_c P_{no} + M_{ux}/\phi_b M_{nx} + M_{uy}/\phi_b M_{ny} \leq 1.0 \quad (\text{Eq. C5-2})$$

When  $P_u/\phi_c P_n \leq 0.15$ , the following formula may be used in lieu of the above two formulas:

$$P_u/\phi_c P_n + M_{ux}/\phi_b M_{nx} + M_{uy}/\phi_b M_{ny} \leq 1.0 \quad (\text{Eq. C5-3})$$

where

$P_u$  = Required axial strength

$M_{ux}$  and  $M_{uy}$  = Required flexural strengths with respect to the centroidal axes of the effective section determined for the required axial strength alone. For angle sections,  $M_{uy}$  shall be taken either as the required flexural strength or the required flexural strength plus  $P_u L/1000$ , whichever results in a lower value of  $P_n$ .

$P_n$  = Nominal axial strength determined in accordance with Section C4.

$P_{no}$  = Nominal axial strength determined in accordance with Section C4, with  $F_n = F_y$

$M_{nx}$  and  $M_{ny}$  = Nominal flexural strengths about the centroidal axes determined in accordance with Section C3

$1/\alpha_{nx}, 1/\alpha_{ny}$  = Magnification factors

$$= 1/(1 - P_u/\phi_c P_E) \quad (\text{Eq. C5-4})$$

$\phi_b$  = 0.95 and 0.90 for bending strength (Section C3.1.1) or 0.90 for laterally unbraced beam (Section C3.1.2)

$\phi_c$  = 0.85

$$P_E = \pi^2 EI_b / (K_b L_b)^2 \quad (\text{Eq. C5-5})$$

$I_b$  = Moment of inertia of the full, unreduced cross section about the axis of bending

$L_b$  = Actual unbraced length in the plane of bending

$K_b$  = Effective length factor in the plane of bending

$C_{mx}, C_{my}$  = Coefficients whose value shall be taken as follows:

1. For compression members in frames subject to joint translation (sidesway)

$$C_m = 0.85$$

2. For restrained compression members in frames braced against joint translation and not subject to transverse loading between their supports in the plane of bending

$$C_m = 0.6 - 0.4 (M_1/M_2) \quad (\text{Eq. C5-6})$$

where

$M_1/M_2$  is the ratio of the smaller to the larger moment at the ends of that portion of the member under consideration which is unbraced in the plane of bending.  $M_1/M_2$  is positive when the member is bent in reverse curvature and negative when it is bent in single curvature.

3. For compression members in frames braced against joint translation in the plane of loading and subject to transverse loading between their supports, the value of  $C_m$  may be determined by rational analysis. However, in lieu of such analysis, the following values may be used:

(a) for members whose ends are restrained,  $C_m = 0.85$ ,

(b) for members whose ends are unrestrained,  $C_m = 1.0$ .

**C6 Cylindrical Tubular Members.** The requirements of this Section apply to cylindrical tubular members having a ratio of outside diameter to wall thickness,  $D/t$ , not greater than  $0.441 E/F_y$ .

**C6.1 Bending.** For flexural members, the required flexural strength uncoupled from axial load, shear, and local concentrated forces or reactions shall not exceed  $\phi_b M_n$ , where  $\phi_b = 0.95$  and  $M_n$  is calculated as follows:

For  $D/t \leq 0.070 E/F_y$

$$M_n = 1.25 F_y S_f \quad (\text{Eq. C6.1-1})$$

For  $0.070 E/F_y < D/t \leq 0.319 E/F_y$

$$M_n = [0.970 + 0.020(E/F_y)/(D/t)]F_y S_f \quad (\text{Eq. C6.1-2})$$

For  $0.319 E/F_y < D/t \leq 0.441 E/F_y$

$$M_n = [0.328E/(D/t)]S_f \quad (\text{Eq. C6.1-3})$$

where

$S_f$  = Elastic section modulus of the full, unreduced cross section

**C6.2 Compression.** The requirements of this Section apply to members in which the resultant of all loads and moments acting on the member is equivalent to a single force in the direction of the member axis passing through the centroid of the section.

The design axial strength,  $\phi_c P_n$ , shall be calculated as follows:

$$\phi_c = 0.85$$

$$P_n = F_n A_e \quad (\text{Eq. C6.2-1})$$

In the above equation,

For  $F_e > F_y/2$

$$\begin{aligned} F_n &= \text{Flexural buckling stress} \\ &= F_y [1 - F_y/4F_e] \end{aligned} \quad (\text{Eq. C6.2-2})$$

$F_e$  = The elastic flexural buckling stress determined according to Section C4.1

$$A_e = [1 - (1 - R^2)(1 - A_o/A)]A \quad (\text{Eq. C6.2-3})$$

$$R = \sqrt{F_y/2F_e} \quad (\text{Eq. C6.2-4})$$

$$A_e = [0.037/(DF_v/tE) + 0.667]A \leq A \text{ for } D/t \leq 0.441E/F_y \quad (\text{Eq. C6.2-5})$$

$A$  = Area of the unreduced cross section

For  $F_e \leq F_y/2$

$$F_n = F_e$$

$$A_e = A$$

**C6.3 Combined Bending and Compression.** Combined bending and compression shall satisfy the provisions of Section C5.

## D. STRUCTURAL ASSEMBLIES

**D1 Built-Up Sections.** **D1.1 I-Sections Composed of Two Channels.** The maximum permissible longitudinal spacing of welds or other connectors,  $s_{max}$ , joining two channels to form an I-section shall be

(a) For compression members:

$$s_{max} = Lr_{cy}/(2r_1) \quad (\text{Eq. D1.1-1})$$

where

$L$  = Unbraced length of compression member

$r_1$  = Radius of gyration of the I-section about the axis perpendicular to the direction in which buckling would occur for the given conditions of end support and intermediate bracing

$r_{cy}$  = Radius of gyration of one channel about its centroidal axis parallel to the web

(b) For flexural members:

$$s_{max} = L/6 \quad (\text{Eq. D1.1-2})$$

In no case shall the spacing exceed the value

$$s_{max} = 2gT_s/(mq) \quad (\text{Eq. D1.1-3})$$

where

$L$  = Span of beam

- $T_s$  = Design strength of connection in tension (Section E)  
 $g$  = Vertical distance between the two rows of connections nearest to the top and bottom flanges  
 $q$  = Intensity of factored load on the beam (For methods of determination, see below)  
 $m$  = Distance from the shear center of one channel to the mid-plane of its web.  
 For simple channels without stiffening lips at the outer edges,  
 $m = w_f^2 / (2w_f + d/3)$  (Eq. D1.1-4)  
 For channels with stiffening lips at the outer edges,  
 $m = w_f dt / (4I_x) [w_f d + 2D(d - 4D^2/3d)]$  (Eq. D1.1-5)  
 $w_f$  = Projection of flanges from the inside face of the web (For channels with flanges of unequal width,  $w_f$  shall be taken as the width of the wider flange)  
 $d$  = Depth of channel or beam  
 $D$  = Overall depth of lip  
 $I_x$  = Moment of inertia of one channel about its centroidal axis normal to the web.

The intensity of factored load,  $q$ , is obtained by dividing the magnitude of factored concentrated loads or reactions by the length of bearing. For beams designed for a uniformly distributed load,  $q$  shall be taken equal to three times the intensity of the uniformly distributed factored load. If the length of bearing of a concentrated load or reaction is smaller than the weld spacing,  $s$ , the required design strength of the welds or connections closest to the load or reaction is

$$T_s = P_s / (2g) \quad (\text{Eq. D1.1-6})$$

where  $P_s$  is a concentrated load or reaction based on factored loads.

The required maximum spacing of connections,  $s_{max}$ , depends upon the intensity of the factored load directly at the connection. Therefore, if uniform spacing of connections is used over the whole length of the beam, it shall be determined at the point of maximum local load intensity. In cases where this procedure would result in uneconomically close spacing, either one of the following methods may be adopted: (a) the connection spacing may be varied along the beam according to the variation of the load intensity; or (b) reinforcing cover plates may be welded to the flanges at points where concentrated loads occur. The design shear strength of the connections joining these plates to the flanges shall then be used for  $T_s$ , and  $g$  shall be taken as the depth of the beam.

**D1.2 Spacing of Connections in Compression Elements.** The spacing,  $s$ , in the line of stress, of welds, rivets, or bolts connecting a cover plate, sheet, or a non-integral stiffener in compression to another element shall not exceed

- (a) that which is required to transmit the shear between the connected parts on the basis of the design strength per connection specified elsewhere herein; nor
- (b)  $1.16t \sqrt{E/f_c}$ , where  $t$  is the thickness of the cover plate or sheet, and  $f_c$  is the stress at service load in the cover plate or sheet; nor
- (c) three times the flat width,  $w$ , of the narrowest unstiffened compression element tributary to the connections, but need not be less than  $1.11t \sqrt{E/F_y}$  if  $w/t < 0.50 \sqrt{E/F_y}$ , or  $1.33t \sqrt{E/F_y}$  if  $w/t \geq 0.50 \sqrt{E/F_y}$ , unless closer spacing is required by (a) or (b) above.

In the case of intermittent fillet welds parallel to the direction of stress, the spacing shall be taken as the clear distance between welds, plus one-half inch. In all other cases, the spacing shall be taken as the center-to-center distance between connections.

Exception: The requirements of this Section do not apply to cover sheets which act only as sheathing material and are not considered as load-carrying elements.

**D2 Mixed Systems.** The design of members in mixed systems using cold-formed steel components in conjunction with other materials shall conform to this Specification and the applicable Specification of the other material.

D3 Lateral Bracing. Braces shall be designed to restrain lateral bending or twisting of a loaded beam or column, and to avoid local crippling at the points of attachment.

D3.1 Symmetrical Beams and Columns. Braces and bracing systems, including connections, shall be designed considering strength and stiffness requirements.

D3.2 Channel-Section and Z-Section Beams. The following provisions for bracing to restrain twisting of channels and Z-sections used as beams loaded in the plane of the web, apply only when (a) the top flange is connected to deck or sheathing material in such a manner as to effectively restrain lateral deflection of the connected flange, or (b) neither flange is so connected. When both flanges are so connected, no further bracing is required.

D3.2.1 Anchorage of Bracing for Roof Systems Under Gravity Load With Top Flange Connected to Sheathing. For channels and Z-sections designed according to Section C3.1.1, and having deck or sheathing fastened directly to the top flanges in such a manner shown to effectively inhibit relative movement between the deck or sheathing and the purlin flange, provisions shall be made to restrain the flanges so that the maximum top flange lateral displacements with respect to the purlin reaction points do not exceed the span length divided by 360. If the top flanges of all purlins face in the same direction, anchorage of the restraint system must be capable of satisfying the requirements of Sections D3.2.1(a) and D3.2.1(b). If the top flanges of adjacent lines of purlins face in opposite directions, the provisions of Section D3.2.1(a) and D3.2.1(b) do not apply.

Anchored braces need to be connected to only one line of purlins in each purlin bay of each roof slope if provision is made to transmit forces from other purlin lines through the roof deck and its fastening system. Anchored braces shall be as close as possible to the flange which is connected to the deck or sheathing. Anchored braces shall be provided for each purlin bay.

For bracing arrangements other than those covered in Sections D3.2.1(a) and D3.2.1(b), tests in accordance with Chapter F shall be performed so that the type and/or spacing of braces selected are such that the test strength of the braced Z-section assembly is equal to or greater than its nominal flexural strength, instead of that required by Chapter F.

(a) Channel Sections. For roof systems using channel sections for purlins with all compression flanges facing in the same direction, a restraint system capable of resisting  $0.05W$ , in addition to other loading, shall be provided where  $W$  is the factored load supported by all purlin lines being restrained. Where more than one brace is used at a purlin line, the restraint force  $0.05W$  shall be divided equally between all braces.

(b) Z-Sections. For roof systems having a diaphragm stiffness of at least 2,000 lb/in. (350 N/mm), having four to twenty Z-purlin lines with all top flanges facing in the direction of the upward roof slope, and with restraint braces at the purlin supports, midspan or one-third points, each brace shall be designed to resist a force determined as follows:

For **SI** in (1) through (6) below:  $\times 4.448$  for **N**.

(1) Single-Span System with Restraints at the Supports:  

$$P_L = 0.5[0.220b^{1.50}/(n_p^{0.72}d^{0.90}t^{0.60}) - \sin\theta]W \quad (\text{Eq. D3.2.1-1})$$

(2) Single-Span System with Third-Point Restraints:  

$$P_L = 0.5[0.474b^{1.22}/(n_p^{0.57}d^{0.89}t^{0.33}) - \sin\theta]W \quad (\text{Eq. D3.2.1-2})$$

(3) Single-Span System with Midspan Restraint:  

$$P_L = [0.224b^{1.32}/(n_p^{0.65}d^{0.83}t^{0.50}) - \sin\theta]W \quad (\text{Eq. D3.2.1-3})$$

(4) Multiple-Span System with Restraints at the Supports:  

$$P_L = C_{tr}[0.053b^{1.88}L^{0.13}/(n_p^{0.95}d^{1.07}t^{0.94}) - \sin\theta]W \quad (\text{Eq. D3.2.1-4})$$

with

$C_{tr} = 0.63$  for braces at end supports of multiple-span systems

$C_{tr} = 0.87$  for braces at the first interior supports

$C_{tr} = 0.81$  for all other braces

(5) Multiple-Span System with Third-Point Restraints:  

$$P_L = C_{th}[0.181b^{1.15}L^{0.25}/(n_p^{0.54}d^{1.11}t^{0.29}) - \sin\theta]W \quad (\text{Eq. D3.2.1-5})$$

with

$C_{th} = 0.57$  for outer braces in exterior spans  
 $C_{th} = 0.48$  for all other braces

(6) Multiple-Span System with Midspan Restraints:  

$$P_L = C_{ms}[0.116b^{1.32}L^{0.18}/(n_p^{0.70}d^{1.00}t^{0.50}) - \sin\theta]W \quad (\text{Eq. D3.2.1-6})$$

with

$C_{ms} = 1.05$  for braces in exterior spans  
 $C_{ms} = 0.90$  for all other braces

where

- $b$  = Flange width, in. (mm)
- $d$  = Depth of section, in. (mm)
- $t$  = Thickness, in. (mm)
- $L$  = Span length, in. (mm)
- $\theta$  = Angle between the vertical and the plane of the web of the Z-section, degrees
- $n_p$  = Number of parallel purlin lines
- $W$  = Total factored load supported by the purlin lines between adjacent supports, pounds (N)

The force,  $P_L$ , is positive when restraint is required to prevent movement of the purlin flanges in the upward roof slope direction.

For systems having less than four purlin lines, the brace force can be determined by taking 1.1 times the force found from Equations D3.2.1-1 through D3.2.1-6, with  $n_p = 4$ . For systems having more than twenty purlin lines, the brace force can be determined from Equations D3.2.1-1 through D3.2.1-6, with  $n_p = 20$ .

D3.2.2 Neither Flange Connected to Sheathing. Each intermediate brace, at the top and bottom flange, shall be designed to resist a required lateral force,  $P_L$ , determined as follows:

- (a) For uniform loads,  $P_L = 1.5K'$  times the factored load within a distance  $0.5a$  each side of the brace.
- (b) For concentrated loads,  $P_L = 1.0K'$  times each concentrated load within a distance  $0.3a$  each side of the brace, plus  $1.4K'(1-x/a)$  times each factored concentrated load located farther than  $0.3a$  but not farther than  $1.0a$  from the brace.

In the above formulas:

For channels and Z-sections:

- $x$  = Distance from the concentrated load to the brace
- $a$  = Distance between center line of braces

For channels:

$$K' = m/d \quad (\text{Eq. D3.2.2-1})$$

where

- $m$  = Distance from the shear center to the mid-plane of the web, as specified in Section D1.1
- $d$  = Depth of channel

For Z-sections:

$$K' = I_{xy}/I_x \quad (\text{Eq. D3.2.2-2})$$

where

- $I_{xy}$  = Product of inertia of the full section about centroidal axes parallel and perpendicular to the web

$I_x$  = Moment of inertia of the full section about the centroidal axis perpendicular to the web  
Braces shall be designed to avoid local crippling at the points of attachment to the member.

Braces shall be attached both to the top and bottom flanges of the sections, at the ends and at intervals not greater than one-quarter of the span length, in such a manner as to prevent tipping at the ends and lateral deflection of either flange in either direction at intermediate braces. If one-third or more of the total factored load on the beam is concentrated over a length of one-twelfth or less of the span of the beam, an additional brace shall be placed at or near the center of this loaded length.

Exception: When all loads and reactions on a beam are transmitted through members which frame into the section in such a manner as to effectively restrain the section against rotation and lateral displacement, no other braces will be required.

D3.3 Laterally Unbraced Box Beams. For closed box-type sections used as beams subject to bending about the major axis, the ratio of the laterally unsupported length to the distance between the webs of the section shall not exceed  $0.086 E/F_y$ .

D4 Wall Studs and Wall Stud Assemblies. The design strength of a stud may be computed on the basis of Section C (neglecting sheathing and using steel only) or on the basis that sheathing (attached to one or both sides of the stud) furnishes adequate lateral and rotational support to the stud in the plane of the wall, provided that the stud, sheathing, and attachments comply with the following requirements:

Both ends of the stud shall be braced to restrain rotation about the longitudinal stud axis and horizontal displacement perpendicular to the stud axis; however, the ends may or may not be free to rotate about both axes perpendicular to the stud axis. The sheathing shall be connected to the top and bottom members of the wall assembly to enhance the restraint provided to the stud and stabilize the overall assembly.

When sheathing is utilized for stability of the wall studs, the sheathing shall retain adequate strength and stiffness for the expected service life of the wall and additional bracing shall be provided as required for adequate structural integrity during construction and in the completed structure.

The equations given are based on solid-web steel studs and are applicable within the following limits:

Yield point,  $F_y \leq 50$  ksi (345 N/mm<sup>2</sup>)

Section depth,  $d \leq 6.0$  in. (152 mm)

Thickness,  $t \leq 0.075$  in. (1.91 mm)

Overall length,  $L \leq 16$  ft. (4877 mm)

Stud spacing,  $B$ , not less than 12 in. (305 mm) nor greater than 24 in. (610 mm)

Studs with perforations shall be designed using the results of stub column tests and/or rational analysis.

D4.1 Wall Studs in Compression. For studs having identical sheathing attached to both flanges, and neglecting any rotational restraint provided by the sheathing, the design axial strength,  $\phi_c P_n$ , shall be calculated as follows:

$$\phi_c = 0.85$$

$$P_n = A_e F_n \text{ (Eq. D4.1-1)}$$

where

$\phi_c$  = Resistance factor for axial compression

$A_e$  = Effective area determined at  $F_n$

$F_n$  = The lowest value determined by the following three conditions:

- (a) To prevent column buckling between fasteners in the plane of the wall,  $F_n$  shall be calculated according to Section C4 with  $KL$  equal to two times the distance between fasteners.

(b) To prevent flexural and/or torsional overall column buckling,  $F_n$  shall be calculated in accordance with Section C4 with  $F_e$  taken as the smaller of the two  $\sigma_{CR}$  values specified for the following section types, where  $\sigma_{CR}$  is the theoretical elastic buckling stress under concentric loading.

(1) Singly-symmetric channels and C-Sections

$$\sigma_{CR} = \sigma_{ey} + \bar{Q}_a \quad (\text{Eq. D4.1-2})$$

$$\sigma_{CR} = [1/(2\beta)] [(\sigma_{ex} + \sigma_{tQ}) - \sqrt{(\sigma_{ex} + \sigma_{tQ})^2 - (4\beta\sigma_{ex}\sigma_{tQ})}] \quad (\text{Eq. D4.1-3})$$

(2) Z-Sections

$$\sigma_{CR} = \sigma_t + \bar{Q}_t \quad (\text{Eq. D4.1-4})$$

$$\sigma_{CR} = (1/2) \left\{ (\sigma_{ex} + \sigma_{ey} + \bar{Q}_a) - \sqrt{(\sigma_{ex} + \sigma_{ey} + \bar{Q}_a)^2 - 4(\sigma_{ex}\sigma_{ey} + \sigma_{ex}\bar{Q}_a - \sigma_{exy}^2)} \right\} \quad (\text{Eq. D4.1-5})$$

(3) I-Sections (doubly-symmetric)

$$\sigma_{CR} = \sigma_{ey} + \bar{Q}_a \quad (\text{Eq. D4.1-6})$$

$$\sigma_{CR} = \sigma_{ex} \quad (\text{Eq. D4.1-7})$$

In the above formulas:

$$\sigma_{ex} = \pi^2 E / (L/r_x)^2 \quad (\text{Eq. D4.1-8})$$

$$\sigma_{exy} = (\pi^2 E I_{xy}) / (AL^2) \quad (\text{Eq. D4.1-9})$$

$$\sigma_{ey} = \pi^2 E / (L/r_y)^2 \quad (\text{Eq. D4.1-10})$$

$$\sigma_t = [1/(Ar_o^2)] [GJ + \pi^2 EC_w / (L)^2] \quad (\text{For SI: } \times 6.89 \text{ for N/mm}^2) \quad (\text{Eq. D4.1-11})$$

$$\sigma_{tQ} = \sigma_t + \bar{Q}_t \quad (\text{Eq. D4.1-12})$$

$\bar{Q}$  =  $\bar{q}B$  = Design shear rigidity for sheathing on both sides of the wall assembly

$\bar{q}$  = Design shear rigidity for sheathing per inch (mm) of stud spacing (see Table D4)

$B$  = Stud spacing

$$\bar{Q}_a = \bar{Q}/A \quad (\text{Eq. D4.1-13})$$

$A$  = Area of full unreduced cross section

$L$  = Length of stud

$$\bar{Q}_t = (\bar{Q}d^2)/(4Ar_o^2) \quad (\text{Eq. D4.1-14})$$

$d$  = Depth of section

$I_{xy}$  = Product of inertia

(c) To prevent shear failure of the sheathing, a value of  $F_n$  shall be used in the following equations so that the shear strain of the sheathing,  $\gamma$ , does not exceed the permissible shear strain,  $\bar{\gamma}$ . The shear strain,  $\gamma$ , shall be determined as follows:

$$\gamma = (\pi/L) [C_1 + (E_1 d/2)] \quad (\text{Eq. D4.1-15})$$

where

$C_1$  and  $E_1$  are the absolute values of  $C_1$  and  $E_1$  specified below for each section type:

(1) Singly-Symmetric Channels and C-Sections

$$C_1 = (F_n C_o) / (\sigma_{ey} - F_n + \bar{Q}_a) \quad (\text{Eq. D4.1-16})$$

$$E_1 = \frac{F_n [(\sigma_{ex} - F_n)(r_o^2 E_o - x_o D_o) - F_n x_o (D_o - x_o E_o)]}{(\sigma_{ex} - F_n) r_o^2 (\sigma_{tQ} - F_n) - (F_n x_o)^2} \quad (\text{Eq. D4.1-17})$$

(2) Z-Sections

$$C_1 = \frac{F_n [C_o (\sigma_{ex} - F_n) - D_o \sigma_{exy}]}{(\sigma_{ey} - F_n + \bar{Q}_a) (\sigma_{ex} - F_n) - \sigma_{exy}^2} \quad (\text{Eq. D4.1-18})$$

$$E_1 = (F_n E_o) / (\sigma_{tQ} - F_n) \quad (Eq. D4.1-19)$$

(3) I-Sections

$$C_1 = (F_n C_o) / (\sigma_{ey} - F_n + \bar{Q}_a) \quad (Eq. D4.1-20)$$

$$E_1 = 0$$

where

$x_o$  = distance from shear center to centroid along principal x-axis, in. (absolute value)

$C_o$ ,  $E_o$ , and  $D_o$  are initial column imperfections which shall be assumed to be at least

$$C_o = L/350 \text{ in a direction parallel to the wall} \quad (Eq. D4.1-21)$$

$$D_o = L/700 \text{ in a direction perpendicular to the wall} \quad (Eq. D4.1-22)$$

$$E_o = L/(d \times 10,000), \text{ rad., a measure of the initial twist of the stud from the initial, ideal, unbuckled shape} \quad (Eq. D4.1-23)$$

If  $F_n > 0.5 F_y$ , then in the definitions for  $\sigma_{ey}$ ,  $\sigma_{ex}$ ,  $\sigma_{exy}$  and  $\sigma_{tQ}$ , the parameters  $E$  and  $G$  shall be replaced by  $E'$  and  $G'$ , respectively, as defined below

$$E' = 4EF_n (F_y - F_n) / F_y^2 \quad (Eq. D4.1-24)$$

$$G' = G (E'/E) \quad (Eq. D4.1-25)$$

Sheathing parameters  $\bar{q}_o$  and  $\bar{\gamma}$  may be determined from representative full-scale tests, conducted and evaluated as described by published documented methods (see Commentary), or from the small-scale-test values given in Table D4.

**TABLE D4**  
**Sheathing Parameters<sup>(1)</sup>**

Sheathing <sup>(2)</sup>	$\bar{q}_o$ <sup>(3)</sup> k/in.	$\bar{\gamma}$ in./in.
	$\times 175.1$ for N/mm	mm/mm
<sup>3</sup> / <sub>8</sub> to <sup>5</sup> / <sub>8</sub> in. (9.5 to 15.9 mm) thick gypsum	2.0	0.008
Lignocellulosic board	1.0	0.009
Fiberboard (regular or impregnated)	0.6	0.007
Fiberboard (heavy impregnated)	1.2	0.010

(1) The values given are subject to the following limitations:

All values are for sheathing on both sides of the wall assembly.

All fasteners are No. 6, type S-12, self-drilling drywall screws with pan or bugle head, or equivalent, at 6- to 12-inch (152 mm to 305 mm) spacing.

(2) All sheathing is <sup>1</sup>/<sub>2</sub>-inch (13 mm) thick except as noted.

$$(3) \bar{q} = \bar{q}_o(2 - s/12) \quad (Eq. D4.1-26)$$

where  $s$  = fastener spacing, in. (mm)

For other types of sheathing,  $\bar{q}_o$  and  $\bar{\gamma}$  may be determined conservatively from representative small-specimen tests as described by published documented methods (see Commentary).

**D4.2 Wall Studs in Bending.** For studs having identical sheathing attached to both flanges, and neglecting any rotational restraint provided by the sheathing, the design flexural strengths are  $\phi_b M_{nxo}$  and  $\phi_b M_{nyo}$

where

$$\phi_b = 0.95 \text{ for sections with stiffened or partially stiffened compression flanges}$$

$$= 0.90 \text{ for sections with unstiffened compression flanges}$$

$$M_{nxo} \text{ and } M_{nyo} = \text{Nominal flexural strengths about the centroidal axes determined in accordance with Section C3.1, excluding the provisions of Section C3.1.2 (lateral buckling)}$$

**D4.3 Wall Studs with Combined Axial Load and Bending.** The required axial strength and flexural strength shall satisfy the interaction equations of Section C5 with the following redefined terms:

$P_n$  = Nominal axial strength determined according to Section D4.1  
 $M_{nx}$  and  $M_{ny}$  in Equations C5-1, C5-2 and C5-3 shall be replaced by nominal flexural strengths,  $M_{n xo}$  and  $M_{n yo}$ , respectively.

**E. CONNECTIONS AND JOINTS**

E1 General Provisions. Connections shall be designed to transmit the maximum forces resulting from the factored loads acting on the connected member. Proper regard shall be given to eccentricity.

E2 Welded Connections. The following LRFD design criteria govern welded connections used for cold-formed steel structural members in which the thickness of the thinnest connected part is 0.18 in. (4.6 mm) or less. For welded connections in which the thickness of the thinnest connected part is greater than 0.18 in. (4.6 mm), refer to the AISC's "Load and Resistance Factor Design Specification for Structural Steel Buildings."

Except as modified herein, arc welds on steel where at least one of the connected parts is 0.18 inch (4.6 mm) or less in thickness shall be made in accordance with the AWS D-1.3 (Reference 3 of Section A6) and its Commentary. Welders and welding procedures shall be qualified as specified in AWS D1.3. These provisions are intended to cover the welding positions as shown in Table E2.

Resistance welds shall be made in conformance with the procedures given in AWS C1.1, "Recommended Practices for Resistance Welding" or AWS C1.3, "Recommended Practice for Resistance Welding Coated Low Carbon Steels."

The required strength on each weld shall not exceed the design strength,  $\phi P_n$ ,

where

$\phi$  = Resistance factor for arc welded connections defined in Sections E2.1 through E2.5.

$P_n$  = Nominal strength of welds determined according to Sections E2.1 through E2.5.

TABLE E2

Connection	Welding Position					
	Square Groove Butt Weld	Arc Spot Weld	Arc Seam Weld	Fillet Weld, Lap or T	Flare-Bevel Groove	Flare-V Groove Weld
Sheet to Sheet	F	—	F	F	F	F
	H	—	H	H	H	H
	V	—	—	V	V	V
	OH	—	—	OH	OH	OH
Sheet to Supporting Member	—	F	F	F	F	—
	—	—	—	H	H	—
	—	—	—	V	V	—
	—	—	—	OH	OH	—

(F = flat, H = horizontal, V = vertical, OH = overhead)

E2.1 Groove Welds in Butt Joints. The design strength,  $\phi P_n$ , of a groove weld in a butt joint, welded from one or both sides, shall be determined as follows:

(a) Tension or compression normal to the effective area or parallel to the axis of the weld

$$\phi = 0.90$$

$$P_n = L_t F_y \tag{Eq. E2.1-1}$$

(b) Shear on the effective area

$$\phi = 0.80$$

$$P_n = L_t (0.6 F_{xx}) ; \text{ and} \tag{Eq. E2.1-2}$$

$$\phi = 0.90$$

$$P_n = L t_e (F_y / \sqrt{3}) \quad (\text{Eq. E2.1-3})$$

where

- $\phi$  = Resistance factor for welded connections
- $P_n$  = Nominal strength of a groove weld
- $F_{xx}$  = Strength level designation in AWS electrode classification
- $F_y$  = Specified minimum yield point of the lower strength base steel
- $L$  = Length of weld
- $t_e$  = Effective throat dimension for groove weld

E2.2 Arc Spot Welds. Arc spot welds permitted by this Specification are for welding sheet steel to thicker supporting members in the flat position. Arc spot welds (puddle welds) shall not be made on steel where the thinnest connected part is over 0.15 inch (3.8 mm) thick, nor through a combination of steel sheets having a total thickness over 0.15 inch (3.8 mm).

Weld washers, Figures E2.2(A) and E2.2(B), shall be used when the thickness of the sheet is less than 0.028 inch (0.71 mm). Weld washers shall have a thickness between 0.05 and 0.08 inch (1.3 mm and 2.0 mm) with a minimum pre-punched hole of  $\frac{3}{8}$ -inch (9.5 mm) diameter.

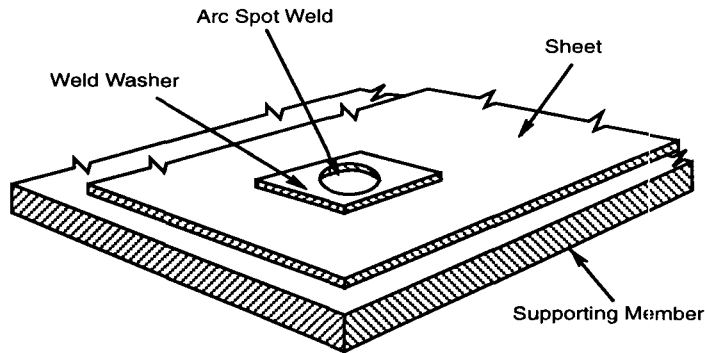

Figure E2.2A Typical Weld Washer

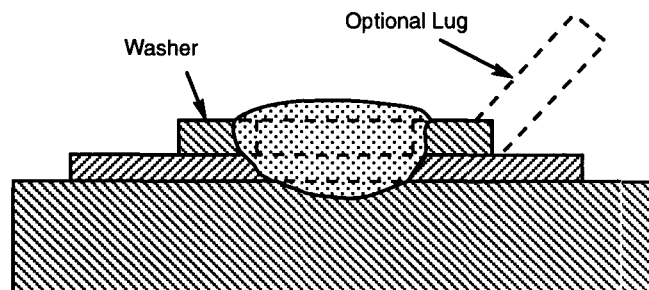

Figure E2.2B Arc Spot Weld Using Washer

Arc spot welds shall be specified by minimum effective diameter of fused area,  $d_e$ . Minimum allowable effective diameter is  $3/8$  inch (9.5 mm).

The design shear strength,  $\phi P_n$ , of each arc spot weld between sheet or sheets and supporting member shall be determined by using the smaller of either

(a)  $\phi = 0.60$   
 $P_n = 0.589 d_e^2 F_{xx}$  ; or (Eq. E2.2-1)

(b) For  $(d_a/t) \leq 0.815 \sqrt{(E/F_u)}$ :  
 $\phi = 0.60$   
 $P_n = 2.20 t d_a F_u$  (Eq. E2.2-2)

For  $0.815 \sqrt{(E/F_u)} < (d_a/t) < 1.397 \sqrt{(E/F_u)}$ :  
 $\phi = 0.50$   
 $P_n = 0.280 [1 + 5.59 \sqrt{(E/F_u)} (d_a/t)] t d_a F_u$  (Eq. E2.2-3)

For  $(d_a/t) \geq 1.397 \sqrt{(E/F_u)}$ :  
 $\phi = 0.50$   
 $P_n = 1.40 t d_a F_u$  (Eq. E2.2-4)

where

$\phi$  = Resistance factor for welded connections

$P_n$  = Nominal shear strength of an arc spot weld

$d$  = Visible diameter of outer surface of arc spot weld

$d_a$  = Average diameter of the arc spot weld at mid-thickness of  $t$  where  $d_a = (d - t)$  for a single sheet, and  $(d - 2t)$  for multiple sheets (not more than four lapped sheets over a supporting member)

$d_e$  = Effective diameter of fused area

$d_e = 0.7d - 1.5t$  but  $\leq 0.55d$  (Eq. E2.2-5)

$t$  = Total combined base steel thickness (exclusive of coatings) of sheets involved in shear transfer

$F_{xx}$  = Stress level designation in AWS electrode classification

$F_u$  = Tensile strength as specified in Section A3.1 or A3.2 or as reduced for low ductility steel.

**Note:** See Figures E2.2(C) and E2.2(D) for diameter definitions

The distance measured in the line of force from the centerline of a weld to the nearest edge of an adjacent weld or to the end of the connected part toward which the force is directed shall not be less than the value of  $e_{min}$  as given on the following page:

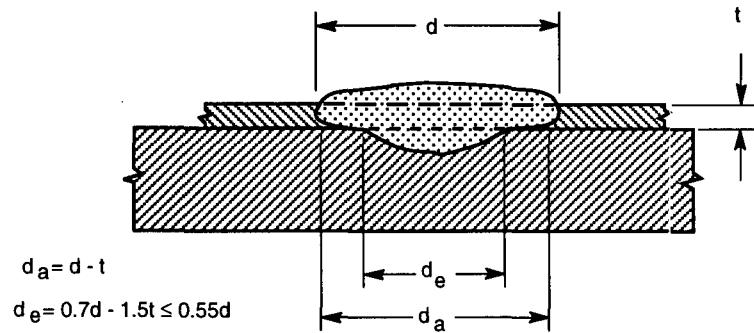

(C) Arc Spot Weld-Single Thickness of Sheet

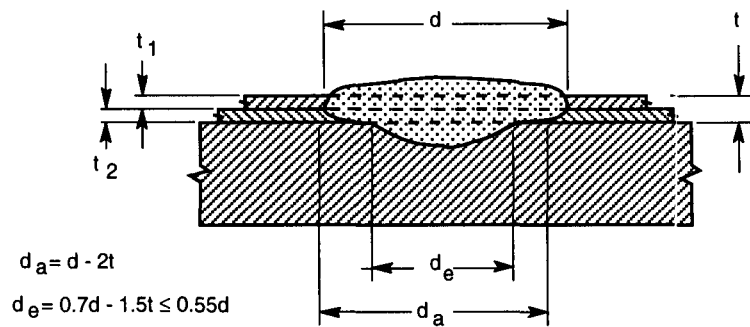

(D) Arc Spot Weld-Double Thickness of Sheet

**Figure E2.2 C, D Arc Spot Welds**

$$e_{min} = P_u / (\phi F_u t) \tag{Eq. E2.2-6}$$

where

- $\phi$  = Resistance factor for welded connections
- = 0.70 when  $F_u / F_{sy} \geq 1.15$
- = 0.60 when  $F_u / F_{sy} < 1.15$

$P_u$  = Required strength transmitted by weld

$t$  = Thickness of thinnest connected sheet

$F_{sy}$  = Yield point as specified in Sections A3.1 or A3.2

**Note:** See Figures E2.2(E) and E2.2(F) for edge distances of arc welds.

In addition, the distance from the centerline of any weld to the end or boundary of the connected member shall not be less than 1.5d. In no case shall the clear distance between welds and the end of member be less than 1.0d.

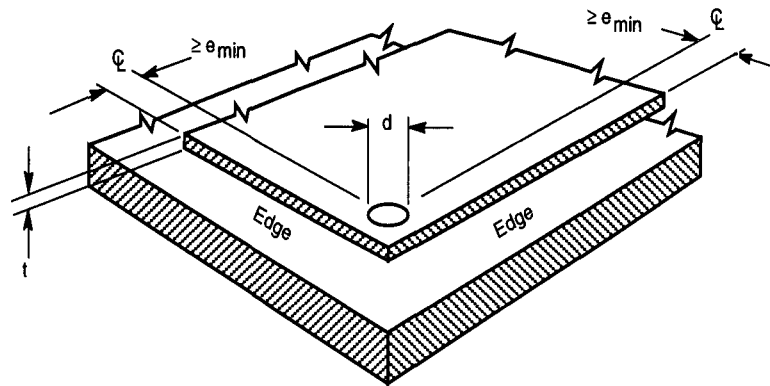

(E) Single Sheet

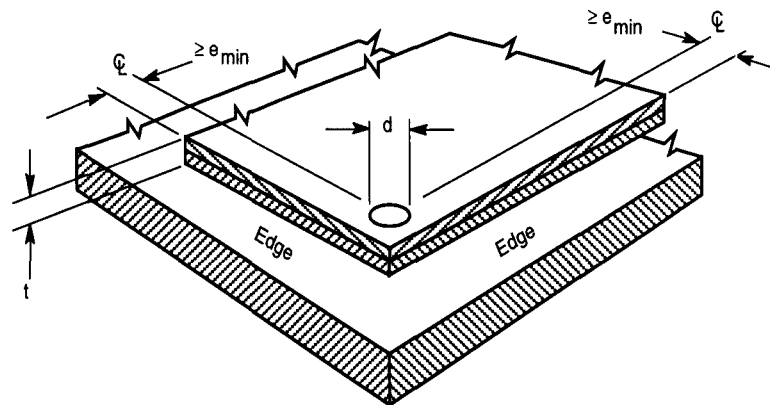

(F) Double Sheet

Figure E2.2 E, F Edge Distances for Arc Spot Welds

The design tensile strength,  $\phi P_n$ , on each arc spot weld between sheet and supporting member, shall be determined as follows:

$$\phi = 0.65$$

$$P_n = 0.7 t d_a F_u$$

(Eq. E2.2-7)

The following additional limitations for use in Eq. 2.2-7 shall apply:

$$e_{min} \geq$$

$$F_{xx} \geq 60 \text{ ksi (414 N/mm}^2\text{)}$$

$$F_u \leq 60 \text{ ksi (414 N/mm}^2\text{)}$$

$$t \geq 0.028 \text{ in. (0.71 mm)}$$

d

If it can be shown by measurement that a given weld procedure will consistently give a larger effective diameter,  $d_e$ , or average diameter,  $d_a$ , as applicable, this larger diameter may be used providing the particular welding procedure used for making those welds is followed.

E2.3 Arc Seam Welds. Arc seam welds [Figure E2.3(A)] covered by this Specification apply only to the following joints:

- (a) Sheet to thicker supporting member in the flat position.
- (b) Sheet to sheet in the horizontal or flat position.

The design shear strength,  $\phi P_n$ , of arc seam welds shall be determined by using the smaller of either

(a)  $\phi = 0.60$   
 $P_n = (nd_e^2/4 + Ld_3)(0.75F_{xx})$ ; or (Eq. E2.3-1)

(b)  $\phi = 0.60$   
 $P_n = 2.5 tF_u(0.25L + 0.96 d_a)$  (Eq. E2.3-2)

where

- $\phi$  = Resistance factor for welded connections
- $P_n$  = Nominal shear strength of an arc seam weld
- $d$  = Width of arc seam weld
- $L$  = Length of seam weld not including the circular ends  
 (For computation purposes,  $L$  shall not exceed  $3d$ )
- $d_a$  = Average width of seam weld

where

$d_a = (d - t)$  for a single sheet, and (Eq. E2.3-3)

$(d - 2t)$  for a double sheet (Eq. E2.3-4)

$d_e =$  Effective width of arc seam weld at fused surfaces

$d_e = 0.7d - 1.5t$  (Eq. E2.3-5)

and  $F_u$  and  $F_{xx}$  are defined in Section E2.2. The minimum edge distance shall be as determined for the arc spot weld, Section E2.2. See Figure E2.3(B).

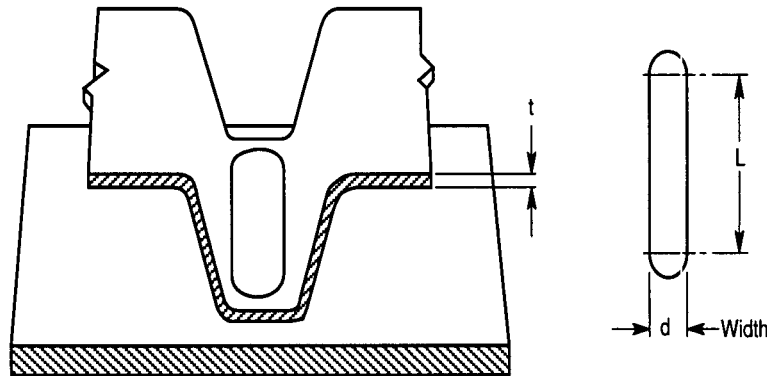

Figure E2.3A Arc Seam Welds – Sheet to Supporting Member in Flat Position

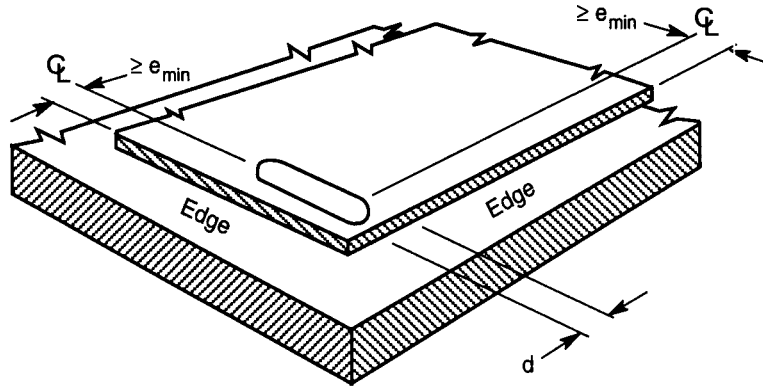

Figure E2.3B Edge Distances for Arc Seam Welds

E2.4 Fillet Welds. Fillet welds covered by this Specification apply to the welding of joints in any position, either

- (a) Sheet to sheet, or
- (b) Sheet to thicker steel member.

The design shear strength,  $\phi P_n$ , of a fillet weld shall be determined as follows:

- (a) For longitudinal loading:

For  $L/t < 25$  :

$$\phi = 0.60$$

$$P_n = 0.75 t_w L F_{xx} \quad (Eq. E2.4-1)$$

For  $L/t \geq 25$ :

$$\phi = 0.55$$

$$P_n = 0.75 t L F_u \quad (Eq. E2.4-2)$$

- (b) For transverse loading:

$$\phi = 0.60$$

$$P_n = t L F_u \quad (Eq. E2.4-3)$$

where  $t$  = Least value of  $t_1$  or  $t_2$ , Figure E2.4

In addition, for  $t > 0.150$  inch (3.8 mm) the design strength determined above shall not exceed the following value of  $\phi P_n$  :

$$\phi = 0.60$$

$$P_n = 0.75 t_w L F_{xx} \quad (Eq. E2.4-4)$$

where

$\phi$  = Resistance factor for welded connections

$P_n$  = Nominal strength of a fillet weld

$L$  = Length of fillet weld

$t_w$  = Effective throat =  $0.707 w_1$  or  $0.707 w_2$ , whichever is smaller. A larger effective throat may be taken if it can be shown by measurement that a given welding procedure will consistently give a larger value providing the particular welding procedure used for making the welds that are measured is followed.

$w_1$  and  $w_2$  = leg on weld (see Figure E2.4).  
 $F_u$  and  $F_{xx}$  are defined in Section E2.2.

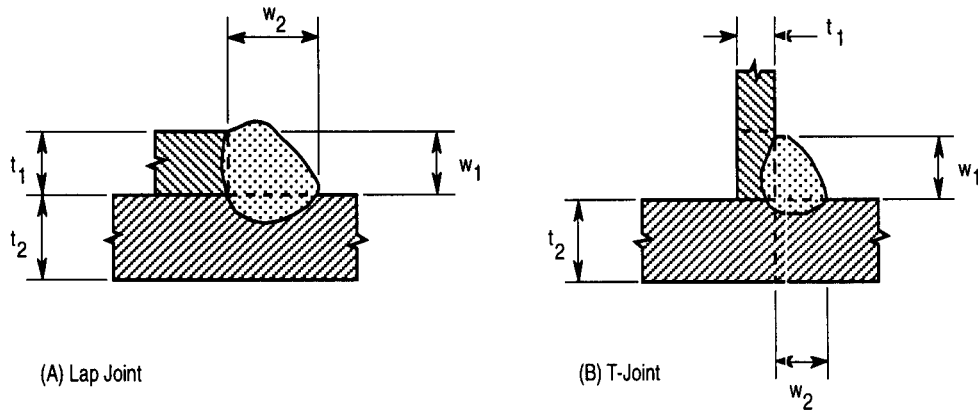

Figure E2.4 Fillet Welds

E2.5 Flare Groove Welds. Flare groove welds covered by this Specification apply to welding of joints in any position, either:

- (a) Sheet to sheet for flare-V groove welds, or
- (b) Sheet to sheet for flare-bevel groove welds, or
- (c) Sheet to thicker steel member for flare-bevel groove welds.

The design shear strength,  $\phi P_n$ , of a flare groove weld shall be determined as follows:

- (a) For flare-bevel groove welds, transverse loading [see Figure E2.5(A)]:

$$\phi = 0.55$$

$$P_n = 0.833tLF_u$$

(Eq. E2.5-1)

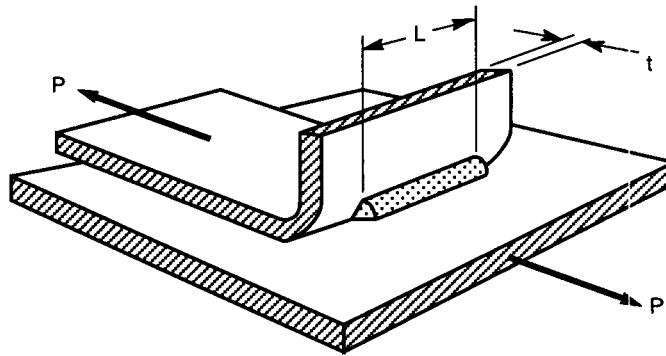

Figure E2.5A Flare-Bevel Groove Weld

- (b) For flare groove welds, longitudinal loading [see Figures E2.5(B), E2.5(C), and E2.5(D)]:

(1) For  $t \leq t_w < 2t$  or if the lip height is less than weld length, L:

$$\phi = 0.55$$

$$P_n = 0.75tLF_u \quad (\text{Eq. E2.5-2})$$

(2) For  $t_w \geq 2t$  and the lip height is equal to or greater than  $L$ :

$$\phi = 0.55$$

$$P_n = 1.50tLF_u \quad (\text{Eq. E2.5-3})$$

In addition, if  $t > 0.15$  inch, the design strength determined above shall not exceed the following value of  $\phi P_n$ :

$$\phi = 0.60$$

$$P_n = 0.75t_wLF_{xx} \quad (\text{Eq. E2.5-4})$$

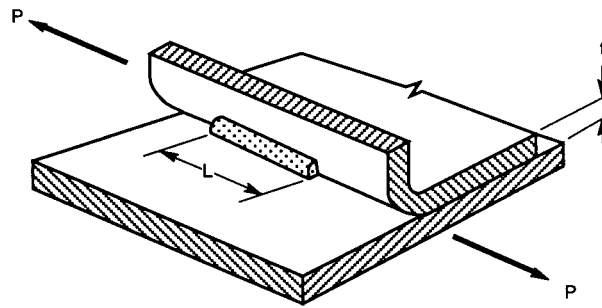

(B) Flare Bevel Groove

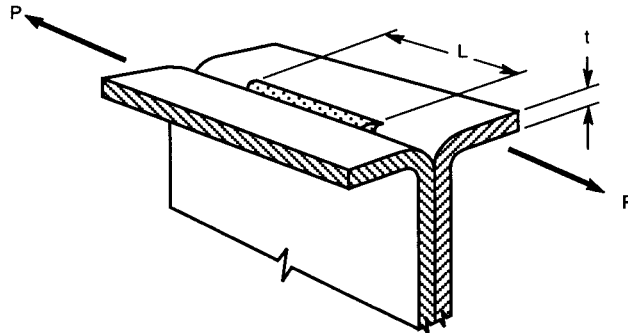

(C) Flare V-Groove

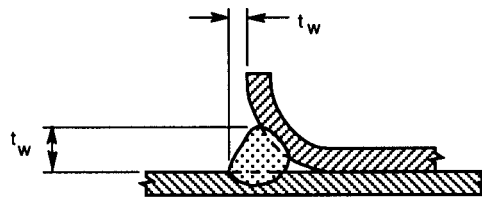

(D) Throat

Figure E2.5 B, C, D Shear in Flare Groove Welds

E2.6 Resistance Welds. The design shear strength,  $\phi P_n$ , of spot welding shall be determined as follows:

$$\phi = 0.65$$

$$P_n = \text{Tabulated value given in Table E2.6}$$

**TABLE E2.6**  
**Nominal Shear Strength of Spot Welding**

Thickness of Thinnest Outside Sheet, in.	Nominal Shear Strength per Spot, kips	Thickness of Thinnest Outside Sheet, in.	Nominal Shear Strength per Spot, kips
× 25.4 for mm	× 4448 for N	× 25.4 for mm	× 4448 for N
0.010	0.13	0.080	3.33
0.020	0.48	0.090	4.00
0.030	1.00	0.100	4.99
0.040	1.42	0.110	6.07
0.050	1.65	0.125	7.29
0.060	2.28	0.190	10.16
0.070	2.83	0.250	15.00

E3 Bolted Connections. The following LRFD design criteria govern bolted connections used for cold-formed steel structural members in which the thickness of the thinnest connected part is less than  $\frac{3}{16}$  inch (4.8 mm). For bolted connections in which the thickness of the thinnest connected part is equal to or greater than  $\frac{3}{16}$  inch (4.8 mm), refer to AISC's "Load and Resistance Factor Design Specification for Structural Steel Buildings," September 1, 1986.

Bolts, nuts, and washers shall generally conform to one of the following specifications:

ASTM A194 Carbon and Alloy Steel Nuts for Bolts for High-Pressure and High-Temperature Service

ASTM A307(Type A), Carbon Steel Externally and Internally Threaded Standard Fasteners

ASTM A325 High Strength Bolts for Structural Steel Joints

ASTM A354 (Grade BD), Quenched and Tempered Alloy Steel Bolts, Studs, and Other Externally Threaded Fasteners (for diameter of bolt smaller than  $\frac{1}{2}$  inch)

ASTM A449 Quenched and Tempered Steel Bolts and Studs (for diameter of bolt smaller than  $\frac{1}{2}$  inch)

ASTM A490 Quenched and Tempered Alloy Steel Bolts for Structural Steel Joints

ASTM A563 Carbon and Alloy Steel Nuts

ASTM F436 Hardened Steel Washers

ASTM F844 Washers, Steel, Plain (Flat), Unhardened for General Use

ASTM F959 Compressible Washer-Type Direct Tension Indicators for Use with Structural Fasteners

When other than the above are used, drawings shall indicate clearly the type and size of fasteners to be employed and the nominal strength assumed in design.

Bolts shall be installed and tightened to achieve satisfactory performance of the connections involved under usual service conditions.

The holes for bolts shall not exceed the sizes specified in Table E3, except that larger holes may be used in column base details or structural systems connected to concrete walls.

**TABLE E3**  
**Maximum Size of Bolt Holes, Inches**

Nominal Bolt Diameter, $d$ in.	Standard Hole Diameter, $d_h$ in.	Oversized Hole Diameter, $d_h$ in.	Short-Slotted Hole Dimensions in.	Long-Slotted Hole Dimensions in.
× 25.4 for mm				
$< 1/2$ $\geq 1/2$	$d + 1/32$ $d + 1/16$	$d + 1/16$ $d + 1/8$	$(d + 1/32)$ by $(d + 1/4)$ $(d + 1/16)$ by $(d + 1/4)$	$(d + 1/32)$ by $(2 - 1/2d)$ $(d + 1/16)$ by $(2 - 1/2d)$

Standard holes shall be used in bolted connections, except that oversized and slotted holes may be used as approved by the designer. The length of slotted holes shall be normal to the direction of the shear load. Washers or backup plates shall be installed over oversized or short-slotted holes in an outer ply unless suitable performance is demonstrated by load tests in accordance with Section F.

E3.1 Spacing and Edge Distance. The design shear strength,  $\phi P_n$ , of the connected part along two parallel lines in the direction of applied force shall be determined as follows:

$$P_n = tF_u \quad (\text{Eq. E3.1-1})$$

(a) When  $F_u/F_{sy} \geq 1.15$ :

$$\phi = 0.70$$

(b) When  $F_u/F_{sy} < 1.15$ :

$$\phi = 0.60$$

where

$\phi$  = Resistance factor

$P_n$  = Nominal resistance per bolt

$e$  = The distance measured in the line of force from the center of a standard hole to the nearest edge of an adjacent hole or to the end of the connected part

$t$  = Thickness of thinnest connected part

$F_u$  = Tensile strength of the connected part as specified in Section A3.1 or A3.2 or as reduced for low-ductility steel

$F_{sy}$  = Yield point of the connected part as specified in Section A3.1 or A3.2 or as reduced for low-ductility steel

In addition, the minimum distance between centers of bolt holes shall provide sufficient clearance for bolt heads, nuts, washers and the wrench but shall not be less than 3 times the nominal bolt diameter,  $d$ . Also, the distance from the center of any standard hole to the end or other boundary of the connecting member shall not be less than  $1\frac{1}{2}d$ .

For oversized and slotted holes, the distance between edges of two adjacent holes and the distance measured from the edge of the hole to the end or other boundary of the connecting member in the line of stress shall not be less than the value of  $e - (d_h/2)$ , in which  $e$  is the required distance computed from the applicable equation given above, and  $d_h$  is the diameter of a standard hole defined in Table E3. In no case shall the clear distance between edges of two adjacent holes be less than  $2d$  and the distance between the edge of the hole and the end of the member be less than  $d$ .

E3.2 Tension in Connected Part. The design tensile strength,  $\phi P_n$ , on the net section of the connected part shall be determined as follows:

(a) Washers are provided under both the bolt head and the nut

$$P_n = (1.0 - 0.9r + 3rd/s) F_u A_n \leq F_u A_n \quad (\text{Eq. E3.2-1})$$

$\phi = 0.65$  for double shear connection

$\phi = 0.55$  for single shear connection

(b) Either washers are not provided under the bolt head and nut, or only one washer is provided under either the bolt head or nut

$$\phi = 0.65$$

$$P_n = (1.0 - r + 2.5rd/s) F_u A_n \leq F_u A_n \quad (Eq. E3.2-2)$$

In addition, the design tensile strength shall not exceed the following values:

$$\phi = 0.95$$

$$P_n = F_y A_n \quad (Eq. E3.2-3)$$

where

$A_n$  = Net area of the connected part

$r$  = Force transmitted by the bolt or bolts at the section considered, divided by the tension force in the member at that section. If  $r$  is less than 0.2, it may be taken equal to zero.

$s$  = Spacing of bolts perpendicular to line of stress.  
In the case of a single bolt,  $s$  = Width of sheet

$F_u$  = Tensile strength of the connected part as specified in Section A3.1 or A3.2 or as reduced for low-ductility steel

$F_y$  = Yield point of the connected part

$d$  and  $t$  are defined in Section E3.1

E3.3 Bearing. The design bearing strength,  $\phi P_n$ , shall be determined by the values of  $\phi$  and  $P_n$  given in Tables E3.3-1 and E3.3-2 for the applicable thickness and  $F_u/F_{sy}$  ratio of the connected part and the type of joint used in the connection.

In Tables E3.3-1 and E3.3-2, the symbols  $\phi$ ,  $P_n$ ,  $d$ ,  $F_u$  and  $t$  were previously defined. For conditions not shown, the design bearing strength of bolted connections shall be determined by tests.

**TABLE E3.3-1**  
**Nominal Bearing Strength for Bolted Connections**  
**with Washers Under Bolt Head and Nut**

Thickness of Connected Part in. ( $\times 25.4$ for mm)	Type of Joint	$F_u/F_{sy}$ ratio of Connected Part	Resistance Factor $\phi$	Nominal Resistance $P_n$
$\geq 0.024$ but $< 3/16$	Inside sheet of double shear connection	$\geq 1.15$	0.55	$3.33F_u dt$
		$< 1.15$	0.65	$3.00F_u dt$
	Single shear and outside sheets of double shear connection	No limit	0.60	$3.00F_u dt$
$\geq 3/16$	See AISC LRFD Specification			

**TABLE E3.3-2**  
**Nominal Bearing Strength for Bolted Connections**  
**without Washers Under Bolt Head and Nut,**  
**or with Only One Washer**

Thickness of Connected Part in. ( $\times 25.4$ for mm)	Type of Joint	$F_u/F_{sy}$ ratio of Connected Part	Resistance Factor $\phi$	Nominal Resistance $P_n$
$\geq 0.036$ but $< 3/16$	Inside sheet of double shear connection	$\geq 1.15$	0.70	$3.00F_u dt$
		$\geq 1.15$	0.65	$2.22F_u dt$
$\geq 3/16$	See AISC LRFD Specification			

E3.4 Shear and Tension in Bolts. The required bolt strength in shear or tension shall not exceed the design strength,  $\phi P_n$ , determined as follows:

$\phi$  = Resistance factor given in Table E3.4-1

$$P_n = A_b F_n \quad (\text{Eq. E3.4-1})$$

where

$A_b$  = Gross cross-sectional area of bolt

$F_n$  is given by  $F_{nv}$  or  $F_{nt}$  in Table E3.4-1.

The pullover strength of the connected sheet at the bolt head, nut or washer should be considered where bolt tension is involved, see Section E5.2.

**TABLE E3.4-1**  
**Nominal Tensile and Shear Strengths for Bolts**

Description of Bolts × 25.4 for mm	Tensile Strength		Shear Strength <sup>1</sup>	
	Resistance Factor $\phi$	Nominal Stress $F_{nt}$ × 6.89 for N/mm <sup>2</sup>	Resistance Factor $\phi$	Nominal Stress $F_{nv}$ × 6.89 for N/mm <sup>2</sup>
A307 Bolts, Grade A ( $1/4$ in. $\leq d < 1/2$ in.)	0.75	40.5	0.65	24.0
A307 Bolts, Grade A ( $d \geq 1/2$ in.)		45.0		27.0
A325 Bolts, when threads are not excluded from shear planes		90.0		54.0
A325 Bolts, when threads are excluded from shear planes		90.0		72.0
A354 Grade B Bolts ( $1/4$ in. $\leq d < 1/2$ in.), when threads are not excluded from shear planes		101.0		59.0
A354 Grade B Bolts ( $1/4$ in. $\leq d < 1/2$ in.), when threads are excluded from shear planes		101.0		90.0
A449 Bolts ( $1/4$ in. $\leq d < 1/2$ in.), when threads are not excluded from shear planes		81.0		47.0
A449 Bolts ( $1/4$ in. $\leq d < 1/2$ in.), when threads are excluded from shear planes		81.0		72.0
A490 Bolts, when threads are not excluded from shear planes		112.5		67.5
A490 Bolts, when threads are excluded from shear planes		112.5		90.0

<sup>1</sup>Applies to bolts in holes as limited by Table E3. Washers or back-up plates shall be installed over long-slotted holes and the capacity of connections using long-slotted holes shall be determined by load tests in accordance with Section F.

When bolts are subject to a combination of shear and tension produced by factored loads, the required tension strength shall not exceed the design strength,  $\phi P_n$ , based on  $\phi = 0.75$  and  $P_n = A_b F'_{nt}$ , where  $F'_{nt}$  is given in Table E3.4-2, in which  $f_v$  is the shear stress produced by the same factored loads. The required shear strength shall not exceed the design shear strength,  $\phi A_b F_{nv}$ , determined in accordance with Table E3.4-1.

**TABLE E3.4-2**  
**Nominal Tension Stress,  $F'_{nt}$ , for Bolts**  
**Subject to the Combination of Shear and Tension**

Description of Bolts	Threads Not Excluded from Shear Planes	Threads Excluded from Shear Planes
$\times 25.4$ for mm	$\times 6.89$ for N/mm <sup>2</sup>	
A325 Bolts	$113-2.4f_v \leq 90$	$113-1.9f_v \leq 50$
A354 Grade BD Bolts	$127-2.4f_v \leq 101$	$127-1.9f_v \leq 101$
A449 Bolts	$101-2.4f_v \leq 81$	$101-1.9f_v \leq 81$
A490 Bolts	$141-2.4f_v \leq 112.5$	$141-1.9f_v \leq 112.5$
A307 Bolts, Grade A when $1/4$ in. $\leq d < 1/2$ in. when $d \geq 1/2$ in.	$47-2.4f_v \leq 40.5$ $52-2.4f_v \leq 45$	

E4 Shear Rupture. At beam-end connections, where one or more flanges are coped and failure might occur along a plane through the fasteners, the required shear strength shall not exceed the design shear strength,  $\phi V_n$ .

where

$$\phi = 0.75$$

$$V_n = 0.6 F_u A_{wn} \quad (\text{Eq. E4-1})$$

$$A_{wn} = (d_{wc} - nd_h)t \quad (\text{Eq. E4-2})$$

$d_{wc}$  = Coped web depth

$n$  = Number of holes in the critical plane

$d_h$  = Hole diameter

$F_u$  = Tensile strength as specified in Section A3.1 or A3.2 or as reduced for low-ductility steel

$t$  = Thickness of coped web

E5 Connections to Other Materials. E5.1 Bearing. Proper provisions shall be made to transfer bearing forces resulting from axial loads and moments from steel components covered by the Specification to adjacent structural components made of other materials. The required bearing strength in the contact area shall not exceed the design strength,  $\phi_c P_p$ .

In the absence of code regulations, the design bearing strength on concrete may be taken as  $\phi_c P_p$ :

On the full area of a concrete support .....  $P_p = 0.85f'_c A_1$

On less than the full area of a concrete support .....  $P_p = 0.85f'_c A_1 \sqrt{A_2/A_1}$

where

$$\phi_c = 0.60$$

$f'_c$  = Specified compression strength of concrete

$A_1$  = Bearing area

$A_2$  = Full cross-sectional area of concrete support

The value of  $\sqrt{A_2/A_1}$  shall not exceed 2.

E5.2 Tension. The pull-over shear/tension forces in the steel sheet around the head of the fastener should be considered as well as the pull-out force resulting from factored axial loads and bending

moments transmitted onto the fastener from various adjacent structural components in the assembly.

The nominal tensile strength of the fastener and the nominal imbedment strength of the adjacent structural component shall be determined by applicable product code approvals, or product specifications and/or product literature.

E5.3 Shear. Proper provisions shall be made to transfer shearing forces from steel components covered by this Specification to adjacent structural components made of other materials. The required shear and/or bearing strength on the steel components shall not exceed that allowed by this Specification. The design shear strength on the fasteners and other material shall not be exceeded. Imbedment requirements are to be met. Proper provision shall also be made for shearing forces in combination with other forces.

## F. TESTS FOR SPECIAL CASES

(a) Tests shall be made by an independent testing laboratory or by a testing laboratory of a manufacturer.

(b) The provisions of Chapter F do not apply to cold-formed steel diaphragms.

F1 Tests for Determining Structural Performance. Where the composition or configuration of elements, assemblies, connections, or details of cold-formed steel structural members are such that calculation of their load-carrying capacity or deflection cannot be made in accordance with the provisions of this Specification, their structural performance shall be established from tests and evaluated in accordance with the following procedure.

(a) Where practicable, evaluation of the test results shall be made on the basis of the average value of test data resulting from tests of not fewer than four identical specimens, provided the deviation of any individual test result from the average value obtained from all tests does not exceed  $\pm 10$  percent. If such deviation from the average value exceeds 10 percent, at least three more tests of the same kind shall be made. The average value of all tests made shall then be regarded as the predicted capacity,  $R_p$ , for the series of the tests. The mean value and the coefficient of variation of the tested-to-predicted load ratios for all tests,  $P_m$  and  $V_p$ , shall be determined for statistical analysis.

(b) The load-carrying capacity of the tested elements, assemblies, connections, or members shall satisfy Eq. F1-1.

$$\phi R_p \geq \sum \gamma_i Q_i \quad (\text{Eq. F1-1})$$

where

$\sum \gamma_i Q_i$  = Required resistance based on the most critical load combination determined in accordance with Section A5.1.4.  $\gamma_i$  and  $Q_i$  are load factors and load effects, respectively.

$R_p$  = Average value of all test results

$\phi$  = Resistance factor

$$= 1.5(M_m F_m P_m) \exp(-\beta_o \sqrt{V_M^2 + V_F^2 + C_p V_p^2 + V_Q^2}), \quad (\text{Eq. F1-2})$$

For beams having tension flange through-fastened to deck or sheathing and with compression flange laterally unbraced,  $\phi$  shall be determined with a coefficient of 1.6 in lieu of 1.5,  $\beta_o = 1.5$ , and  $V_Q = 0.43$ .

$M_m$  = Mean value of the material factor listed in Table F1 for the type of component involved

$F_m$  = Mean value of the fabrication factor listed in Table F1 for the type of component involved

$P_m$  = Mean value of the tested-to-predicted load ratios determined in Section F1(a)

$\beta_o$  = Target reliability index

= 2.5 for structural members and 3.5 for connections

- $V_M$  = Coefficient of variation of the material factor listed in Table F1 for the type of component involved  
 $V_F$  = Coefficient of variation of the fabrication factor listed in Table F1 for the type of component involved  
 $C_P$  = Correction factor  
 $= (n - 1)/(n - 3)$  (Eq. F1-3)  
 $V_P$  = Coefficient of variation of the tested-to-predicted load ratios determined in Section F1(a)  
 $n$  = Number of tests  
 $V_Q$  = Coefficient of variation of the load effect  
 $= 0.21$

**TABLE F1**  
**Statistical Data for the Determination of Resistance Factor**

Type of Component	$M_m$	$V_M$	$F_m$	$V_F$
Transverse Stiffeners	1.10	0.10	1.00	0.05
Shear Stiffeners	1.00	0.06	1.00	0.05
Tension Members	1.10	0.10	1.00	0.05
Flexural Members				
Bending Strength	1.10	0.10	1.00	0.05
Lateral Buckling Strength	1.00	0.06	1.00	0.05
One Flange Through-Fastened to Deck or Sheathing	1.10	0.10	1.00	0.05
Shear Strength	1.10	0.10	1.00	0.05
Combined Bending and Shear	1.10	0.10	1.00	0.05
Web Crippling Strength	1.10	0.10	1.00	0.05
Combined Bending and Web Crippling	1.10	0.10	1.00	0.05
Concentrically Loaded Compression Members	1.10	0.10	1.00	0.05
Combined Axial Load and Bending	1.05	0.10	1.00	0.05
Cylindrical Tubular Members				
Bending Strength	1.10	0.10	1.00	0.05
Axial Compression	1.10	0.10	1.00	0.05
Wall Studs and Wall Stud Assemblies				
Wall Studs in Compression	1.10	0.10	1.00	0.05
Wall Studs in Bending	1.10	0.10	1.00	0.05
Wall Studs with Combined Axial Load and Bending	1.05	0.10	1.00	0.05
Welded Connections				
Arc Spot Welds				
Shear Strength of Welds	1.10	0.10	1.00	0.10
Plate Failure	1.10	0.08	1.00	0.15
Arc Seam Welds				
Shear Strength of Welds	1.10	0.10	1.00	0.10
Plate Tearing	1.10	0.10	1.00	0.10
Fillet Welds				
Shear Strength of Welds	1.10	0.10	1.00	0.10
Plate Failure	1.10	0.08	1.00	0.15
Flare Groove Welds				
Shear Strength of Welds	1.10	0.10	1.00	0.10
Plate Failure	1.10	0.10	1.00	0.10
Resistance Welds	1.10	0.10	1.00	0.10
Bolted Connections				
Minimum Spacing and Edge Distance	1.10	0.08	1.00	0.05
Tension Strength on Net Section	1.10	0.08	1.00	0.05
Bearing Strength	1.10	0.08	1.00	0.05

$n$  = number of tests.

$V_Q$  = coefficient of variation of the load effect.  
= 0.21

The listing in Table F1 does not exclude the use of other documented statistical data if they are established from sufficient results on material properties and fabrication.

For steels not listed in Section A3.1, the values of  $M_m$  and  $V_M$  shall be determined by the statistical analysis for the materials used.

When distortions interfere with the proper functioning of the specimen in actual use, the load effects based on the critical load combination at the occurrence of the acceptable distortion shall also satisfy Eq. F1-1, except that the resistance factor  $\phi$  is taken as unity and that the load factor for dead load may be taken as 1.0.

(c) If the yield point of the steel from which the tested sections are formed is larger than the specified value, the test results shall be adjusted down to the specified minimum yield point of the steel which the manufacturer intends to use. The test results shall not be adjusted upward if the yield point of the test specimen is less than the minimum specified yield point. Similar adjustments shall be made on the basis of tensile strength instead of yield point where tensile strength is the critical factor.

Consideration must also be given to any variation or differences which may exist between the design thickness and the thickness of the specimens used in the tests.

**F2 Tests for Confirming Structural Performance.** For structural members, connections, and assemblies whose capacities can be computed according to this Specification or its specific references, confirmatory tests may be made to demonstrate the load-carrying capacity not less than the nominal resistance,  $R_n$ , specified in this Specification or its specific references for the type of behavior involved.

**F3 Tests for Determining Mechanical Properties.** F3.1 Full Section. Tests for determination of mechanical properties of full sections to be used in Section A5.2.2 shall be made as specified below:

(a) Tensile testing procedures shall agree with Standard Methods and Definitions for Mechanical Testing of Steel Products, ASTM A370. Compressive yield point determinations shall be made by means of compression tests of short specimens of the section.

(b) The compressive yield stress shall be taken as the smaller value of either the maximum compressive strength of the sections divided by the cross section area or the stress defined by one of the following methods:

(1) For sharp yielding steel, the yield point shall be determined by the autographic diagram method or by the total strain under load method.

(2) For gradual yielding steel, the yield point shall be determined by the strain under load method or by the 0.2 percent offset method.

When the total strain under load method is used, there shall be evidence that the yield point so determined agrees within 5 percent with the yield point which would be determined by the 0.2 percent offset method

(c) Where the principal effect of the loading to which the member will be subjected in service will be to produce bending stresses, the yield point shall be determined for the flanges only. In determining such yield points, each specimen shall consist of one complete flange plus a portion of the web of such flat width ratio that the value of  $\rho$  for the specimen is unity.

(d) For acceptance and control purposes, two full section tests shall be made from each lot of not more than 50 tons (45 360 kg) nor less than 30 tons (27 216 kg) of each section, or one test from each lot of less than 30 tons (27 216 kg) of each section. For this purpose a lot may be defined as that tonnage of one section that is formed in a single production run of material from one heat.

(e) At the option of the manufacturer, either tension or compression tests may be used for routine acceptance and control purposes, provided the manufacturer demonstrates that such tests reliably

indicate the yield point of the section when subjected to the kind of stress under which the member is to be used.

**F3.2 Flat Elements of Formed Sections.** Tests for determining mechanical properties of flat elements of formed sections and representative mechanical properties of virgin steel to be used in Section A5.2.2 shall be made in accordance with the following provisions:

The yield point of flats,  $F_{yf}$ , shall be established by means of a weighted average of the yield points of standard tensile coupons taken longitudinally from the flat portions of a representative cold-formed member. The weighted average shall be the sum of the products of the average yield point for each flat portion times its cross sectional area, divided by the total area of flats in the cross section. The exact number of such coupons will depend on the shape of the member, i.e., on the number of flats in the cross section. At least one tensile coupon shall be taken from the middle of each flat. If the actual virgin yield point exceeds the specified minimum yield point, the yield point of the flats,  $F_{yf}$ , shall be adjusted by multiplying the test values by the ratio of the specified minimum yield point to the actual virgin yield point.

### **F3.3 Virgin Steel**

The following provisions apply to steel produced to other than the ASTM Specifications listed in Section A3.1 when used in sections for which the increased yield point of the steel after cold forming shall be computed from the virgin steel properties according to Section A5.2.2. For acceptance and control purposes, at least four tensile specimens shall be taken from each lot as defined in Section F3.1(d) for the establishment of the representative values of the virgin tensile yield point and ultimate strength. Specimens shall be taken longitudinally from the quarter points of the width near the outer end of the coil.

## Chapter 23 WOOD

### Division I—GENERAL

#### SECTION 2301 — SCOPE

The quality and design of wood members and their fastenings shall conform to the provisions of this chapter.

#### SECTION 2302 — DEFINITIONS AND SYMBOLS

**2302.1 Definitions.** The following terms used in this chapter shall have the meanings indicated in this section:

**AFPA** is the American Forest and Paper Association, 1111 19th Street, N.W., Suite 800, Washington, D.C. 20036 (formerly NFOPA, National Forest Products Association).

**AHA** is the American Hardboard Association, Inc., 1210 W. Northwest Highway, Palatine, Illinois 60067.

**AITC** is the American Institute of Timber Construction, 7012 S. Revere Parkway, Suite 140, Englewood, Colorado 80112.

**APA** is the American Plywood Association, 7011 South 19th Street, Tacoma, Washington 98411.

**AWPA** is the American Wood Preservers Association, Post Office Box 285, Woodstock, Maryland 21163-0286.

**BLOCKED DIAPHRAGM** is a diaphragm in which all sheathing edges not occurring on framing members are supported on and connected to blocking.

**BRACED WALL LINE** is a series of braced wall panels in a single story which meets the requirements of Section 2326.11.3.

**BRACED WALL PANEL** is a section of wall braced in accordance with Section 2326.11.3.

**CONVENTIONAL LIGHT-FRAME CONSTRUCTION** is a type of construction whose primary structural elements are formed by a system of repetitive wood-framing members. Refer to Section 2326 for conventional light-frame construction provisions.

**DIAPHRAGM** is a horizontal or nearly horizontal system acting to transmit lateral forces to the vertical resisting elements. When the term "diaphragm" is used, it includes horizontal bracing systems.

**FIBERBOARD** is a fibrous-felted, homogeneous panel made from lignocellulosic fibers (usually wood or cane) and having a density of less than 31 pounds per cubic foot ( $497 \text{ kg/m}^3$ ) but more than 10 pounds per cubic foot ( $160 \text{ kg/m}^3$ ).

**GLUED BUILT-UP MEMBERS** are structural elements, the sections of which are composed of built-up lumber, wood structural panels or wood structural panels in combination with lumber, all parts bonded together with adhesives.

**GRADE (Lumber)**, the classification of lumber in regard to strength and utility in accordance with the grading rules of an approved lumber grading agency.

**HARDBOARD** is a fibrous-felted, homogeneous panel made from lignocellulosic fibers consolidated under heat and pressure in a hot press to a density not less than 31 pounds per cubic foot ( $497 \text{ kg/m}^3$ ).

**NELMA** is the Northeastern Lumber Manufacturers Association, 4 Fundy Road, Falmouth, Maine 04105.

**NHPMA** is the Northern Hardwood and Pine Manufacturers Association (served by NELMA), 4 Fundy Road, Falmouth, Maine 04105.

**NLGA** is the National Lumber Grades Authority, Post Office Box 97, Granges, B.C., Canada V0S 1E0.

**NOMINAL SIZE (Lumber)**, the commercial size designation of width and depth, in standard sawn lumber and glued-laminated lumber grades; somewhat larger than the standard net size of dressed lumber, in accordance with U.B.C. Standard 23-1 for sawn lumber.

**NORMAL LOADING**, a design load that stresses a member or fastening to the full allowable stress tabulated in this chapter. This loading may be applied for approximately 10 years, either continuously or cumulatively, and 90 percent of this load may be applied for the remainder of the life of the member or fastening.

**PARTICLEBOARD** is a manufactured panel product consisting of particles of wood or combinations of wood particles and wood fibers bonded together with synthetic resins or other suitable bonding system by a bonding process in accordance with U.B.C. Standard 23-4.

**PLYWOOD** is a panel of laminated veneers conforming to U.B.C. Standard 23-2 or 23-3.

**RIS** is the Redwood Inspection Service, 591 Redwood Highway, Suite 3100, Mill Valley, California 94941.

**ROTATION** is the torsional movement of a diaphragm about a vertical axis.

**SPIB** is the Southern Pine Inspection Bureau, 4709 Scenic Highway, Pensacola, Florida 32504.

**STRUCTURAL GLUED-LAMINATED TIMBER** is any member comprising an assembly of laminations of lumber in which the grain of all laminations is approximately parallel longitudinally, in which the laminations are bonded with adhesives.

**SUBDIAPHRAGM** is a portion of a larger wood diaphragm designed to anchor and transfer local forces to primary diaphragm struts and the main diaphragm.

**TREATED WOOD** is wood treated with an approved preservative under treating and quality control procedures.

**WCLIB** is the West Coast Lumber Inspection Bureau, 6980 S.W. Varnes Road, Post Office Box 23145, Portland, Oregon 97223.

**WOOD OF NATURAL RESISTANCE TO DECAY OR TERMITES** is the heartwood of the species set forth below. Corner sapwood is permitted on 5 percent of the pieces provided 90 percent or more of the width of each side on which it occurs is heartwood. Recognized species are:

Decay resistant:	Redwood, Cedars, Black Locust
Termite resistant:	Redwood, Eastern Red Cedar

**WOOD STRUCTURAL PANEL** is a structural panel product composed primarily of wood and meeting the requirements of U.B.C. Standard 23-2 or 23-3. Wood structural panels include all-veneer plywood, composite panels containing a combination of veneer and wood-based material, and matformed panels such as oriented strand board and waferboard.

**WWPA** is the Western Wood Products Association, 1500 Yeon Building, Portland, Oregon 97204.

**2302.2 Symbols.** The symbols used in this chapter have the following definitions:

$A$  = area of cross section.

$A_1$  = in fastener group analysis, cross-sectional area of main wood member before boring or grooving, square inches ( $\text{mm}^2$ ).

$A_2$  = in fastener group analysis, sum of cross-sectional areas of wood or metal side member before boring or grooving, square inches ( $\text{mm}^2$ ).

- $b$  = breadth (width) of rectangular member.  
 $C$  = coefficient, constant or factor.  
 $C_c$  = curvature factor.  
 $C_{cs}$  = critical section factor for round timber piles.  
 $C_D$  = load-duration factor.  
 $C_d$  = penetration depth factor.  
 $C_{eg}$  = end grain factor.  
 $C_F$  = size factor for sawn lumber.  
 $C_f$  = form factor.  
 $C_{fu}$  = flat-use factor.  
 $C_g$  = group action factor.  
 $C_{lb}$  = lag screw factor.  
 $C_r$  = repetitive member factor for dimension lumber.  
 $C_{st}$  = metal side plate factor.  
 $C_M$  = wet service factor.  
 $C_T$  = buckling stiffness factor for sawn lumber.  
 $C_m$  = toenail factor.  
 $C_V$  = volume factor for structural glued-laminated timber.  
 $C_{\Delta}$  = geometry factor.  
 $c$  = distance from neutral axis to extreme fiber.  
 $D$  = diameter.  
 $d$  = depth of rectangular member, or least dimension of compression member.  
 $d_e$  = effective depth of member at a connection, inches (mm).  
 $d_n$  = depth of member remaining at a notch, inches (mm).  
 $d_1, d_2$  = cross-sectional dimensions of rectangular compression member in planes of lateral support, inches (mm).  
 $E, E'$  = tabulated and allowable modulus of elasticity, pounds per square inch ( $N/mm^2$ ).  
 $e$  = eccentricity.  
 $F_b, F_b'$  = tabulated and allowable bending design value, pounds per square inch ( $N/mm^2$ ).  
 $F_{bE}$  = critical buckling design value for bending members.  
 $F_c, F_c'$  = tabulated and allowable compression design value parallel to grain, pounds per square inch ( $N/mm^2$ ).  
 $F_{cE}$  = critical buckling design value for compression members.  
 $F_{c\perp}, F_{c\perp}'$  = tabulated and allowable compression design value perpendicular to grain, pounds per square inch ( $N/mm^2$ ).  
 $F_g, F_g'$  = tabulated and allowable bearing design value parallel to grain, pounds per square inch ( $N/mm^2$ ).  
 $F_n$  = allowable unit stress acting perpendicular to the inclined surface, pounds per square inch ( $N/mm^2$ ) (Hankinson's Formula).  
 $F_r$  = allowable unit radial stress.  
 $F_{rc}$  = allowable unit radial stress in compression.  
 $F_{rt}$  = allowable unit radial stress in tension.  
 $F_t, F_t'$  = tabulated and allowable tension design value parallel to grain, pounds per square inch ( $N/mm^2$ ).

- $F_v, F_v'$  = tabulated and allowable shear design value parallel to grain, pounds per square inch (N/mm<sup>2</sup>).
- $F_y$  = bending yield strength of fastener, pounds per square inch (N/mm<sup>2</sup>).
- $F_{\theta}'$  = allowable bearing design value at an angle to grain, pounds per square inch (N/mm<sup>2</sup>).
- $f_b$  = actual unit stress for extreme fiber in bending.
- $f_c$  = actual unit stress in compression parallel to grain.
- $f_{c \perp}$  = actual unit stress in compression perpendicular to grain.
- $f_g$  = actual unit stress in end grain in bearing parallel to grain.
- $f_r$  = actual unit radial stress.
- $f_{rc}$  = actual unit radial stress in compression.
- $f_{rt}$  = actual unit radial stress in tension.
- $f_t$  = actual unit stress in tension parallel to grain.
- $f_v$  = actual unit horizontal shear stress.
- $G$  = specific gravity.
- $g$  = gage of screw.
- $h$  = rise.
- $I$  = moment of inertia, inches<sup>4</sup> (mm<sup>4</sup>).
- $K_{bE}$  = Euler buckling coefficient for beams.
- $K_{cE}$  = Euler buckling coefficient for columns.
- $K_e$  = effective buckling length coefficient for compression members.
- $K_r$  = radial stress coefficient.
- $K_v$  = shear coefficient.
- $K_x$  = spaced column fixity coefficient.
- $L$  = span length of beam, or unsupported length of column, feet (mm).
- $l$  = span length of beam, or unsupported length of column, inch (mm).
- $l_b$  = bearing length, inches (mm).
- $l_c$  = clear span, inches (mm).
- $l_e$  = effective span length of bending member or effective length of compression member, inches (mm).
- $l_e/d$  = slenderness ratio of compression member.
- $l_u$  = laterally unsupported span length of bending member, inches (mm).
- $l_1, l_2$  = distances between points of lateral support of compression member in planes 1 and 2, inches (mm).
- $l_3$  = distance from center of spacer block to centroid of group of split ring or shear plate connectors in end block for a spaced column, inches (mm).
- $M$  = bending moment.
- $m$  = unit bending moment.
- $N$  = acting perpendicular to the inclined surface " $lb$ " (Hankinson's Formula).
- $n$  = number of fasteners in a row.
- $P$  = total concentrated load, or axial compression load.
- $P/A$  = induced axial load per unit of cross-sectional area.
- $p$  = depth of fastener penetration into wood member, inches (mm).
- $Q$  = statical moment of an area about the neutral axis.
- $R$  = radius of curvature.

- $R_B$  = slenderness factor of bending member.  
 $R_H$  = horizontal reaction.  
 $R_V$  = vertical reaction.  
 $r$  = radius of gyration.  
 $S$  = section modulus.  
 $s$  = spacing between adjacent fasteners in a row, inches (mm).  
 $T$  = total axial tension load.  
 $t$  = thickness.  
 $V$  = shear force.  
 $W$  = total uniform load.  
 $w$  = uniform load per unit of length.  
 $x$  = distance from beam support face to load, inches (mm).  
 $\gamma$  = load/slip modulus for a connection, pounds per inch (N/mm).  
 $Z, Z'$  = nominal and allowable lateral design value for a single fastener connection, pounds (N).  
 $\Delta_A$  = allowable deformation or deflection.  
 $\Delta_a$  = actual deformation or deflection.  
 $\theta$  = angle between the direction of load and the direction of grain, degrees (Hankinson's Formula).

## SECTION 2303 — GENERAL

**2303.1 Standard of Quality.** The standards listed below labeled a "U.B.C. standard" are also listed in Chapter 35, Part II, and are part of this code. The other standards listed below are recognized standards. (See Sections 3502 and 3503.)

### 1. Grading rules.

- 1.1 U.B.C. Standard 23-1, Classification, Definition and Methods of Grading for All Species of Lumber
- 1.2 Standard Grading Rules for Canadian Lumber, United States Edition, NLGA
- 1.3 Standard Grading Rules No. 17, WCLIB
- 1.4 Standard Grading Rules, WWPA
- 1.5 Grading Rules, NHPMA
- 1.6 Grading Rules, SPIB
- 1.7 Standard Specifications for Grades of California Redwood Lumber, RIS
- 1.8 Standard Grading Rules, NELMA

### 2. Structural glued-laminated timber.

- 2.1 ANSI/AITC Standard A190.1 and ASTM D 3737, Design and Manufacture of Structural Glued-laminated Timber
- 2.2 Standard Specifications for Structural Glued-laminated Timber of Softwood Species, AITC 117; Manufacturing, AITC 117; Design and Standard Specifications for Hardwood Glued-laminated Timber, AITC 119.
- 2.3 Inspection Manual AITC 200 of the American Institute of Timber Construction, Tests for Structural Glued-laminated Timber.

- 2.4 AITC 500, Determination of Design Values for Structural Glued-laminated Timber in accordance with ASTM D 3737, American Institute of Timber Construction.
- 3. **Preservative treatment by pressure processes and quality control.**
  - Standard Specifications C1, C2, C3, C4, C9, C14, C15, C16, C22, C23, C24, C28 and M4, AWPA
- 4. **Product standards.**
  - 4.1 U.B.C. Standard 23-2, Construction and Industrial Plywood
  - 4.2 U.B.C. Standard 23-3, Performance Standard for Wood-Based Structural-Use Panels
  - 4.3 U.B.C. Standard 23-4, Mat-formed Wood Particleboard
  - 4.4 ANSI 05.1, Wood Poles—Specifications and Dimensions
  - 4.5 ASTM D 25, Round Timber Piles
  - 4.6 ANSI/AHA A194.1, Cellulosic Fiber Insulating Board (Fiberboard)
  - 4.7 ANSI/AHA 135.6, Hardboard Siding
- 5. **Design.**
  - ASTM D 5055, Structural Capacities of Prefabricated Wood I-Joists
- 6. **Fire retardancy.**
  - 6.1 U.B.C. Standard 23-5, Fire-retardant-treated Wood Tests on Durability and Hygroscopic Properties
  - 6.2 U.B.C. Standard 23-6, Fire-retardant-treated Wood
- 7. **Adhesives and glues.**
  - 7.1 ASTM D 3024, Dry Use Adhesives with Protein Base, Casein Type
  - 7.2 ASTM D 2559, Wet Use Adhesives
  - 7.3 APA Specification AFG-01, Adhesives for Field Gluing Plywood to Wood Framing
  - 7.4 ASTM D 1101 and AITC 200 in Testing of Glue Joints in Laminated Wood Product.
- 8. **Design values.**
  - 8.1 ASTM D 1990, Establishing Allowable Properties for Visually-Graded Dimension Lumber from In-Grade Tests of Full-Size Specimens.
  - 8.2 ASTM D 245, Establishing Structural Grades and Related Allowable Properties for Visually Graded Lumber.
  - 8.3 ASTM D 2555, Standard Test Methods for Establishing Clear Wood Strength Values.

**2303.2 Minimum Capacity or Grade.** Minimum capacity of structural framing members may be established by performance tests. When tests are not made, capacity shall be based on allowable stresses and design criteria specified in this code.

Studs, joists, rafters, foundation plates or sills, planking 2 inches (51 mm) or more in depth, beams, stringers, posts, structural sheathing and similar load-bearing members shall be of at least the minimum grades set forth in Table 23-I-A-1, 23-I-A-2 or 23-I-A-3. Approved end-jointed lumber may be used interchangeably with solid-sawn members of the same species and grade. Such use shall include, but not be limited to, light-framing joists, planks and decking.

- Wood structural panels shall be one of the grades specified in U.B.C. Standard 23-2 or 23-3.

**2303.3 Dried Fire-retardant-treated Wood.** Approved fire-retardant-treated wood shall be dried, following treatment, to a maximum moisture content as follows: solid-sawn lumber 2 inches (51 mm) in thickness or less to 19 percent, and plywood to 15 percent.

**2303.4 Metal-plate-connected Wood Trusses.** Metal-plate-connected wood trusses shall conform to the provisions of Section 2311.6 and Division III.

**2303.5 Size of Structural Members.** Sizes of lumber and structural glued-laminated timber referred to in this code are nominal sizes. Computations to determine the required sizes of members shall be based on the net dimensions (actual sizes) and not the nominal sizes.

**2303.6 Shrinkage.** Consideration shall be given in the design to the possible effect of cross-grain dimensional changes considered vertically which may occur in lumber fabricated in a green condition.

**2303.7 Fabrication.** Preparation, fabrication and installation of wood members and their fastenings shall conform to accepted engineering practices and to the requirements of this code.

**2303.8 Workmanship.** All members shall be framed, anchored, tied and braced so as to develop the strength and rigidity necessary for the purposes for which they are used.

**2303.9 Rejection.** The building official may deny permission for the use of a wood member where permissible grade characteristics or defects are present in such a combination that they affect the serviceability of the member.

## SECTION 2304 — STRESSES

**2304.1 General.** Except as hereinafter provided, stresses shall not exceed the allowable unit stresses for the respective species and grades or fabricated products as set forth in Tables 23-I-A-1, 23-I-A-2, 23-I-A-3, 23-I-A-4, and 23-I-A-5 for lumber, and Tables 23-I-C-1, 23-I-C-2 and 23-I-D for structural glued-laminated timber.

Tabulated allowable design values ( $F_b$ ,  $F_t$ ,  $F_v$ ,  $F_c$ ,  $F_{c\perp}$ ,  $E$ ,  $F_g$ ), shall be multiplied by all applicable adjustments factors to determine allowable design values ( $F_b'$ ,  $F_t'$ ,  $F_v'$ ,  $F_c'$ ,  $F_{c\perp}'$ ,  $E'$ ,  $F_g$ ). Table 23-I-A-6 specifies the adjustment factors which apply to each tabulated design value for structural sawn lumber and glued-laminated timber.

The values for  $F_b$  and  $F_c$  tabulated in Tables 23-I-A-1, 23-I-A-2, 23-I-A-4 and 23-I-A-5 for visually graded structural lumber and in Table 23-I-A-3 for machine, stress-rated lumber are for the design of structures when the strength of an individual member is premised on the assumption that each individual piece carries its design load.

The repetitive member adjustment factors for  $F_b$  may be used for the design of an assembly of repetitive framing such as joists, rafters and studs not over 4 inches (102 mm) in thickness spaced not more than 24 inches (610 mm), not less than three in number and joined by transverse load-distributing elements adequate to support the design load.

Values for species and grades not tabulated shall be approved by the building official.

Values for plywood structural panels shall be in accordance with Table 23-I-B. All wood structural panels, when designed to be exposed in outdoor applications, shall be of the exterior type, except as provided in Sections 2322.2 and 2326.12.9.

**2304.2 Wood Poles or Piles.** The values tabulated in Table 23-I-E shall be used for the design of round timber poles and piles.

### 2304.3 Adjustment of Stresses.

**2304.3.1 General.** The allowable unit stresses specified in this chapter shall be subject to the adjustments set forth in the footnotes to the appropriate stress tables and to the requirements of this section.

**2304.3.2 Preservative treatment.** The values for wood pressure impregnated with an approved process and preservative need no adjustment for treatment but are subject to other adjustments.

**2304.3.3 Fire-retardant treatment.** The values for lumber and plywood pressure impregnated with approved fire-retardant chemicals, including fastener values, shall be recommended by the treater and submitted to the building official for approval. Submittal to the building official shall include all substantiating data. Such values shall be developed from approved test methods and procedures that consider potential strength-reduction characteristics, including effects of elevated temperatures and moisture. Other adjustments are applicable, except that the impact load-duration factor shall not apply.

Values for glued-laminated timber, including fastener designer loads, shall be recommended by the treater and submitted to the building official for approval. Submittal to the building official shall include all substantiating data.

In addition to the requirements specified in Section 207, fire-retardant lumber having structural applications shall be tested and identified by an approved inspection agency in accordance with U.B.C. Standard 23-6.

**2304.3.4 Duration of load.** Values for wood and mechanical fastenings (when the wood determines the load capacity) are subject to the following adjustments for the various durations of loading:

1. Where a member is fully stressed to the maximum allowable stress, either continuously or cumulatively, for more than 10 years under the conditions of maximum design load, the values shall not exceed 90 percent of those in the tables.

2. When the accumulated duration of the full maximum load during the life of the member does not exceed the period indicated below, the values may be increased in the tables as follows:

15 percent for two months' duration, as for snow

25 percent for seven days' duration, as for roof loads

33<sup>1</sup>/<sub>3</sub> percent for earthquake

33<sup>1</sup>/<sub>3</sub> percent for wind (for connections and fasteners)

60 percent for wind (members only)

100 percent for impact

except that the increases for wind or earthquake are not combined with the increase allowed in Section 1603.5.

The foregoing increases are not cumulative. For combined duration of loadings the resultant structural members shall not be smaller than required for the longer duration of loading.

The duration of load factors in this item shall not apply to compression-perpendicular-to-grain design values based on a deformation limit, or to modulus of elasticity.

3. Values for normal loading conditions may be used without regard to impact if the stress induced by impact does not exceed the values for normal loading.

**2304.3.5 Size factor adjustment.** Bending, tension and compression parallel to grain design values for visually graded dimension lumber 2 inches to 4 inches (51 mm to 102 mm) thick shall be multiplied by the size factors specified in Tables 23-I-A-1 to 23-I-A-5. When the depth of a rectangular sawn lumber bending member 5 inches (127 mm) or thicker exceeds 12 inches (305 mm), the bending design values,  $F_b$ , shall be multiplied by the size factor,  $C_F$ , as determined by the formula:

$$C_F = (12/d)^{1/9}$$

For SI:

$$C_F = (304.8/d)^{1/9}$$

**WHERE:**

- $C_F$  = size factor.
- $d$  = depth of beam in inches (mm).

For beams of circular cross section that have a diameter greater than 13.5 inches (343 mm), or 12-inch (305 mm) or larger square beams loaded in the plane of the diagonal, the size factor  $C_F$  may be determined on the basis of an equivalent conventionally loaded square beam of the same cross-sectional area.

Size factor adjustments are cumulative with form factor adjustments specified in Section 2304.3.7, except for lumber I beams and box beams, but are not cumulative with slenderness factor adjustments specified in Section 2304.3.6. Volume factor adjustments for glued-laminated members shall be in accordance with Section 2312.4.5. The size factor adjustment shall not apply to machine-stress-rated lumber.

**2304.3.6 Slenderness factor and flexural stress.** When the depth of a bending member exceeds its breadth, allowable design stresses in bending shall be modified as specified in Division VIII, Section 2363.

**EXCEPTION:** Lateral support may be provided in accordance with Section 2306.7 in lieu of the above stress modifications.

**2304.3.7 Form factor adjustments.** The allowable unit stress in bending for nonprismatic members shall not exceed the value established by multiplying such stress by the form factor  $C_f$  determined as follows:

Beam Section	Form Factor ( $C_f$ )
Circular	1.180
Square (with diagonal vertical)	1.414
Lumber I beams and box beams	$0.81 \left[ 1 + \left( \frac{d^2 + 143}{d^2 + 88} - 1 \right) C_g \right]$
For SI:	$0.81 \left[ 1 + \left( \frac{\left(\frac{d}{25.4}\right)^2 + 143}{\left(\frac{d}{25.4}\right)^2 + 88} - 1 \right) C_g \right]$

**WHERE:**

- $C_f$  = form factor.
- $C_g$  = support factor =  $p^2(6 - 8p + 3p^2)(1 - q) + q$ .
- $p$  = ratio of depth of compression flange to full depth of beam.
- $q$  = ratio of thickness of web or webs to the full width of beam.

The form factor adjustment shall be cumulative with the size factor adjustment, except for lumber I beams and box beams.

**2304.3.8 Modulus of elasticity adjustment.** The use of average modulus of elasticity  $E$  values are appropriate for the design of normal wood structural members and assemblies. In special applications where deflections are critical to the stability of structures or structural components, and where exposed to varying temperature and relative humidity under sustained loading conditions, the average values of the modulus of elasticity  $E$  listed in Tables 23-I-A-1, 23-I-A-2, 23-I-C-1, 23-I-C-2, 23-I-D and 23-I-E shall be reduced to account for variability. Coefficients of variation  $C_v$  in the modulus of elasticity  $E$  for lumber and glued-laminated timber are as follows:

	$C_v$
Visually graded sawn lumber	0.25
Machine stress-rated sawn lumber	0.11
Glued-laminated timber	0.10*

\* Applies to six or more laminations.

The average modulus of elasticity  $E$  values listed in the tables shall be multiplied by  $1 - C_v$  or  $1 - 1.65 C_v$  to obtain a modulus of elasticity  $E$  value exceeded by 84 percent or 95 percent individual pieces, respectively.

The duration-of-load adjustments specified in Section 2304.3.4 do not apply to modulus of elasticity values.

**2304.3.9 Temperature.** The allowable unit stresses for untreated and preservative-treated wood specified in this chapter and as modified in this section apply to uses within the range of climatic temperature ordinarily encountered in buildings. When manufacturing or equipment processes subject members to prolonged temperatures above this range, but not exceeding 150°F. (66°C.), the allowable design stresses shall be decreased by the appropriate reduction factors specified in Division VII. Wood members shall not be used in areas subject to temperatures above 150°F. (66°C.) unless the exposure is infrequent and any permanent loss in strength is accounted for in the design.

The allowable unit stresses for fire-retardant-treated solid-sawn lumber and plywood, including fastener values, subject to prolonged elevated temperatures from manufacturing or equipment processes, but not exceeding 150°F. (66°C.), shall be developed from approved test methods that properly consider potential strength-reduction characteristics, including effects of heat and moisture.

**2304.3.10 Moisture service conditions.** Where sawn lumber and fastenings are exposed to service conditions causing the wood to possess more than 19 percent moisture content, the tabulated design values shall be reduced as specified in Table 23-I-A-1, Footnote 6, and Table 23-I-A-2, Footnote 7. Where glued-laminated timber exceeds 16 percent moisture content, the tabulated design values shall be reduced as specified in Table 23-I-C-1, Footnote 2.

**2304.3.11 Bolted joints.** Bolt values used in conjunction with metal side plates shall be in accordance with Division III.

## SECTION 2305 — IDENTIFICATION

All lumber, wood structural panels, particleboard, structural glued-laminated timber, end-jointed lumber, fiberboard sheathing (when used structurally), hardboard siding (when used structurally), piles and poles regulated by this chapter shall conform to the applicable standards or grading rules specified in this code and shall be so identified by the grade mark or a certificate of inspection issued by an approved agency.

All preservatively treated wood required to be treated under Section 2317 shall be identified by the quality mark of an approved inspection agency.

## SECTION 2306 — HORIZONTAL MEMBER DESIGN

**2306.1 Beam Span.** For simple beams, the span shall be taken as the distance from face to face of supports, plus one half the required length of bearing at each end; for continuous beams, the span is the distance between centers of bearings on supports over which the beam is continuous.

### 2306.2 Flexure.

**2306.2.1 Circular cross section.** A beam of circular cross section may be assumed to have the same strength in flexure as a square beam having the same cross-sectional area. If a circular beam is tapered, it shall be considered a beam of variable cross section.

**2306.2.2 Notching.** If possible, notching of beams should be avoided. Notches in sawn lumber bending members shall not exceed one sixth the depth of the member and shall not be located in the middle third of the span. Where members are notched at the ends, the notch depth shall not exceed one fourth the beam depth. The tension side of sawn lumber bending members of 4 inches (102 mm) or greater nominal thickness shall not be notched except at ends of members. Cantilevered portions of beams less than 4 inches (102 mm) in nominal thickness shall not be notched unless the reduced section properties and lumber defects are considered in the design. For effects of notch on shear strength, see Section 2306.4.

**2306.2.3 Lateral moment distribution.** Lateral moment distribution of a concentrated load from a critically loaded beam to adjacent parallel beams shall be calculated.

**2306.3 Horizontal Shear.** The actual shear stress in a solid-sawn or glued-laminated wood beam shall be calculated by means of Formula (6-1).

$$f_v = \frac{3V}{2bd} \quad (6-1)$$

The actual unit shear stress  $f_v$  shall not exceed the allowable for the species and grade as given in Tables 23-I-A-1, 23-I-A-2, 23-I-A-3, 23-I-A-4 and 23-I-A-5 for solid-sawn lumber and in Tables 23-I-C-1, 23-I-C-2 and 23-I-D for glued-laminated lumber, adjusted for duration of loading, as provided in Section 2304.3.4.

When calculating the shear force,  $V$ , distribution of load to adjacent parallel beams by flooring or other members may be considered, and all loads within a distance from either support equal to the depth of the beam may be neglected for beams supported by full bearing on one surface and loads applied to the opposite surface.

**2306.4 Horizontal Shear in Notched Beams.** When rectangular-shaped girders, beams or joists are notched at points of support on the tension side, they shall meet the design requirements of that section in bending and in shear. The actual shear stress at such point shall be calculated by Formula (6-2):

$$f_v = \frac{3V}{2bd_n} \left( \frac{d}{d_n} \right) \quad (6-2)$$

**WHERE:**

$d$  = total depth of beam.

$d_n$  = actual depth of beam at notch.

When girders, beams or joists with circular cross section are notched at points of support on the tension side, they shall meet the design requirements of that section in bending and in shear. The actual shear stress at such point shall be calculated by Formula (6-3).

$$f_v = \left( \frac{3V}{2A_n} \right) \left( \frac{d}{d_n} \right) \quad (6-3)$$

**WHERE:**

$A_n$  = cross-sectional area of notched member.

$d$  = total depth of beam.

$d_n$  = actual depth of beam at notch.

For bending members with other than rectangular or circular cross section and notched at points of support on the tension side, the actual shear stress parallel to grain shall be calculated in accordance with conventional engineering mechanics.

When girders, beams or joists are notched at points of support on the compression side, they shall meet design requirements for that net section in bending and in shear. The shear at such point shall not exceed the value calculated by Formula (6-4):

$$V = \frac{2}{3} F_v b \left[ d - \left( \frac{d - d'}{d'} \right) e \right] \quad (6-4)$$

**WHERE:**

- $d$  = total depth of beam.
- $d'$  = actual depth of beam at notch.
- $e$  = distance notch extends inside the inner edge of support.

The shear for the notch on the compression side shall be further limited to the value determined for a beam of depth  $d'$  if  $e$  exceeds  $d'$ .

The alternate provisions of Division VIII, Section 2364, do not apply when designing notched beams.

**2306.5 Design of Joints in Shear.** Eccentric connector and bolted joints and bearings supported by connectors or bolts shall be designed so that  $f_v$  in Formula (6-5) does not exceed the allowable unit stresses in horizontal shear.

$$f_v = \frac{3V}{2bd_e} \quad (6-5)$$

**WHERE:**

$d_e$  (with connectors) = the depth of the member less the distance from the unloaded edge of member to the nearest edge of the nearest connector.

$d_e$  (with bolts or lag screws) = the depth of the member less the distance from the unloaded edge of the member to the center of the nearest bolt or lag screw.

Allowable unit stresses in shear for joints involving bolts or connectors loaded perpendicular to grain may be 50 percent greater than the horizontal shear values as set forth in Tables 23-I-A-1, 23-I-A-2, 23-I-A-3, 23-I-A-4, 23-I-A-5, 23-I-C-1, 23-I-C-2 and 23-I-D, provided that the joint occurs at least five times the depth of the member from its end. When the joint is less than five times the depth of the member from its end, the induced shear stress is calculated in Formula (6-6).

$$f_v = \frac{3V}{2bd_e} \left( \frac{d}{d_e} \right) \quad (6-6)$$

and the 50 percent increase in design values for shear in joints does not apply.

**2306.6 Compression Perpendicular to Grain.** In applications where deformation is critical, Formula (6-7) shall be used to calculate the compression-perpendicular-to-grain design values.

$$F_{c\perp}' = 0.73 F_{c\perp} \quad (6-7)$$

**WHERE:**

$F_{c\perp}$  = compression-perpendicular-to-grain values from Tables 23-I-A-1 and 23-I-A-2.

$F_{c\perp}'$  = critical compression-perpendicular-to-grain value.

The duration of load modification factors given in Section 2304.3.4 shall not apply to compression-perpendicular-to-grain values for sawn lumber or glued-laminated timber.

The allowable unit stresses for compression perpendicular to grain in Tables 23-I-A-1, 23-I-A-2, 23-I-A-3, 23-I-A-4, 23-I-A-5, 23-I-C-1, 23-I-C-2, and 23-I-D apply to bearings of any length at the ends of the beam and to all bearings 6 inches (152 mm) or more in length at any other location.

For bearings of less than 6 inches (152 mm) in length and not nearer than 3 inches (76 mm) to the end of a member, the maximum allowable load per square inch may be obtained by multiplying the allowable unit stresses in compression perpendicular to grain by the factor indicated in Formula (6-8).

$$C_b = \frac{l_b + 0.375}{l_b} \quad (6-8)$$

For SI:

$$C_b = \frac{l_b + 9.5}{l_b}$$

in which  $l_b$  is the length of bearing in inches (mm) measured along the grain of the wood.

The multiplying factors for indicated lengths of bearing on such small areas as plates and washers may be:

LENGTH OF BEARING (Inches)							
× 25.4 for mm	1/2	1	1 1/2	2	3	4	6 OR MORE
Factor	1.75	1.38	1.25	1.19	1.13	1.10	1.00

In using the preceding formula and table for round washers or bearing areas, use a length equal to the diameter.

In joists supported on a ribbon or ledger board and spiked to the studding, the allowable stress in compression perpendicular to grain may be increased 50 percent.

**2306.7 Lateral Support.** Solid-sawn rectangular lumber beams, rafters and joists shall be supported laterally to prevent rotation or lateral displacement in accordance with the following:

If the ratio of depth to thickness, based on nominal dimensions, is:

1. Two to 1, no lateral support is required.
2. Three to 1 or 4 to 1, the ends shall be held in position, as by full-depth solid blocking, bridging, nailing or bolting to other framing members, approved hangers or other acceptable means.
3. Five to 1, one edge shall be held in line for its entire length.
4. Six to 1, bridging, full-depth solid blocking or cross bracing shall be installed at intervals not exceeding 8 feet (2438 mm) unless:
  - 4.1 Both edges of the member are held in line or,
  - 4.2 The compression edge of the member is supported throughout its length to prevent lateral displacement, as by adequate sheathing or subflooring, and the ends and all points of bearing have lateral support to prevent rotation.
5. Seven to 1, both edges shall be held in line for their entire length.

If a beam is subject to both flexure and compression parallel to grain, the ratio may be as much as 5 to 1 if one edge is held firmly in line. If under any combination of load the unbraced edge of the member is in tension, the ratio may be 6 to 1.

In lieu of providing lateral support by the methods specified in Items 2 through 5 above, the allowable stresses shall be reduced by the slenderness factor set forth in Section 2304.3.6.

**2306.8 Lateral Support of Arches, Compression Chords of Trusses and Studs.** Where roof joists or purlins are used between arches or compression chords, the largest value of  $l_e/d$ , calculated using the depth of the arch or compression chord or calculated using the breadth (least dimension) of the arch or compression chord between points of intermittent lateral support, shall be used. The roof joists or purlins shall be placed to account for shrinkage (for example, by placing the upper edges of unseasoned joists approximately 5 percent of the joist depth above the tops of the arch or chord) but also placed low enough to provide adequate lateral support.

Where roof joists or purlins are placed on top of an arch or compression chord and are securely fastened to the arch or compression chord, the largest value of  $l_e/d$ , calculated using the depth of the arch or compression chord or calculated using the breadth (least dimension) of the arch or compression chord between points of intermittent lateral support, shall be used.

Where planks are placed on top of an arch or compression chord and securely fastened to the arch or compression chord, or when sheathing is nailed properly to the top chord of trussed rafters, the

depth rather than the breadth of the arch, compression chord or trussed rafter may be used as the least dimension in determining  $l_e/d$ . Where stud walls in light-frame construction are adequately sheathed on at least one side, the depth rather than breadth of the stud, may be taken as the least dimension in calculating the  $l_e/d$  ratio. The sheathing shall be shown by experience to provide lateral support and shall be fastened in accordance with Table 23-I-Q.

**SECTION 2307 — COLUMN DESIGN**

**2307.1 Column Classifications.**

**2307.1.1 Simple solid-wood columns.** Simple columns consist of a single piece or of pieces properly glued together to form a single member.

**2307.1.2 Spaced columns, connector joined.** Spaced columns are formed of two or more individual members with their longitudinal axes parallel, separated at the ends and middle points of their length by blocking and joined at the ends by timber connectors capable of developing the required shear resistance. See Division II for design.

**2307.1.3 Built-up columns.** Built-up columns, other than connector-joined spaced columns and glued-laminated columns, shall not be designed as solid columns.

**2307.2 Limitation on  $l/d$  Ratios.** For simple solid columns,  $l_e/d$  shall not exceed 50.

For individual members of a spaced column, see Division II.

**2307.3 Simple Solid-column Design.** The effective column length,  $l_e$ , shall be used in design formulas given in this section. The effective column length,  $l_e$ , shall be determined in accordance with good engineering practice. Actual column lengths,  $l$ , may be multiplied by the factors given in the following table to determine effective column length,  $l_e$ .

Buckling modes						
Design buckling factor, $K_c$ , when ideal conditions approximated.	0.65	0.80	1.2	1.0	2.10	2.4
End condition code						
		Rotation fixed, translation fixed				
		Rotation free, translation fixed				
		Rotation fixed, translation free				
		Rotation free, translation free				

Note:  $l_e = K_c l$

Allowable unit stresses in pounds per square inch of cross-sectional area of square or rectangular solid columns shall be determined in accordance with the following formula:

$$F'_c = F_c * \left[ \frac{1 + (F_{cE}/F_c *)}{2c'} - \sqrt{\left( \frac{1 + (F_{cE}/F_c *)}{2c'} \right)^2 - \frac{(F_{cE}/F_c *)}{c'}} \right]$$

in which

$c' = 0.8$  for sawn lumber.

$c' = 0.85$  for round timber piles.

$c' = 0.9$  for glued-laminated timbers.

$$F_{cE} = \frac{K_{cE} E'}{(l_e/d)^2}$$

$F_c^*$  = tabulated compression design value multiplied by all of the applicable adjustment factors.

$K_{cE} = 0.3$  for visually graded lumber.

$K_{cE} = 0.418$  for products such as machine stress-rated sawn lumber and glued-laminated timber.

**2307.4 Tapered Columns.** When designing a tapered column with a rectangular cross section, tapered at one or both ends, the representative dimension,  $d_{rep}$ , for each face of the column shall be derived as follows:

$$d_{rep} = d_{min} + (d_{max} - d_{min}) \left[ a - 0.15(1 - d_{min}/d_{max}) \right]$$

**WHERE:**

$d_{max}$  = the maximum dimension,  $d$ , for that face of the column.

$d_{min}$  = the minimum dimension,  $d$ , for that face of the column.

**Support Conditions**

Large end fixed, small end unsupported  $a = 0.70$

Small end fixed, large end unsupported  $a = 0.30$

Both ends simply supported:

Tapered toward one end  $a = 0.50$

Tapered toward both ends  $a = 0.70$

For all other support conditions:

$$d = d_{min} + (d_{max} - d_{min}) (1/3)$$

The design of a column of round cross section shall be based on the design calculations for a square column of the same cross-sectional area and having the same degree of taper.

**SECTION 2308 — FLEXURAL AND AXIAL LOADING COMBINED**

**2308.1 Flexure and Axial Tension.** Members subjected to both flexure and axial tension shall be so proportioned that

$$\frac{f_t}{F_t'} + \frac{f_b}{F_b^*} \leq 1.0$$

and

$$\frac{f_b - f_t}{F_b^{**}} \leq 1.0$$

**WHERE:**

$F_b^*$  = tabulated bending design value multiplied by all applicable adjustment factors except  $C_L$ .

$F_b^{**}$  = tabulated bending design value multiplied by all applicable adjustment factors except  $C_V$ .

The load duration factor associated with the shortest duration load in a combination of loads shall be permitted to be used to calculate  $F_t'$  and  $F_b^*$ .

**2308.2 Flexure and Axial Compression.** Members subjected to a combination of flexure about one or both principal axes and axial compression shall be so proportioned that:

$$\left[ \frac{f_c}{F_c'} \right]^2 + \frac{f_{b1}}{F_{b1}'[1 - (f_c/F_{cE1})]} + \frac{f_{b2}}{F_{b2}'[1 - (f_c/F_{cE2}) - (f_{b1}/F_{bE1})^2]} \leq 1.0$$

in which  $f_c < F_{cE1} = \frac{K_{cE}E'}{(l_{e1}/d_1)^2}$  for either uniaxial or biaxial bending

and

$$f_c < F_{cE2} = \frac{K_{cE}E'}{(l_{e2}/d_2)^2} \text{ for biaxial bending}$$

and

$$f_{b1} < F_{bE} = \frac{K_{bE}E'}{(R_B)^2} \text{ for biaxial bending}$$

**WHERE:**

$d_1$  = wide face dimension.

$d_2$  = narrow face dimension.

$f_{b1}$  = actual edgewise bending stress (bending load applied to narrow face of member).

$f_{b2}$  = actual flatwise bending stress (bending load applied to wide face of member).

$K_{bE}$  = 0.438 for visually graded lumber.

$K_{bE}$  = 0.609 for products such as machine stress-rated lumber and glued-laminated timber.

$K_{cE}$  = per Section 2307.3.

$R_B$  = per Division VIII.

Effective column lengths,  $l_{e1}$  and  $l_{e2}$ , shall be determined in accordance with Section 2307.3. The load duration factor associated with the shortest duration load in a combination of loads shall be permitted to be used to calculate  $F_c'$ ,  $F_{b1}'$  and  $F_{b2}'$ .

**2308.3 Spaced Columns.** In the case of spaced columns, this combined stress formula may be applied only if the bending is in a direction parallel to the greater  $d$  of the individual member.

**2308.4 Truss Compression Chords.** Effects of buckling of a 2-inch by 4-inch (51 mm by 102 mm) or smaller truss compression chord having effective buckling lengths of 96 inches (2438 mm) or less and with  $3/8$ -inch (9.5 mm) or thicker plywood sheathing nailed to the narrow face of the chord in accordance with Table 23-I-Q shall be determined from the formula:

$$C_T = 1 + \frac{2,300l_e}{E_{0.05}}$$

For SI: 
$$C_T = 1 + \frac{0.62l_e}{E_{0.05}}$$

**WHERE:**

$C_T$  = buckling stiffness factor.

= 0.819E for machine-stress-rated lumber.

$E$  = modulus of elasticity from tables of allowable unit stresses, pounds per square inch (N/mm<sup>2</sup>).

$E_{0.05}$  = 0.589E for visually graded lumber.

$l_e$  = effective buckling length used in design of chord for compression loading, inches (mm).

The values of  $C_T$  determined from this formula are for wood seasoned to a moisture content of 19 percent or less at the time the plywood is nailed to the chord. For wood that is unseasoned or partially seasoned at the time of plywood attachment,  $C_T$  shall be determined from the formula:

$$C_T = 1 + \frac{1,200l_e}{E_{0.05}}$$

For SI:

$$C_T = 1 + \frac{0.33l_e}{E_{0.05}}$$

For chords with an effective buckling length greater than 96 inches (2438 mm),  $C_T$  shall be taken as the value for a chord having an effective length of 96 inches (2438 mm).

The buckling stiffness factor does not apply to short columns or to trusses used under wet conditions. The allowable unit compressive stress shall be modified by the buckling stiffness factor when a truss chord is subjected to combined flexure and compression and the bending moment is in the direction that induces compression stresses in the chord face to which the plywood is attached.

The buckling stiffness factor  $C_T$  shall be applied as follows:

Short columns ( $l_e/d$  of 11 or less):

$$F'_c = F_c$$

Intermediate columns ( $l_e/d$  greater than 11 but less than  $K$ ):

$$K = 0.671 \sqrt{C_T(E/F_c)}$$

$$F'_c = F_c \left[ 1 - \frac{1}{3} \left( \frac{l_e/d}{K} \right)^4 \right]$$

Long columns ( $l_e/d$  of  $K$  or greater):

$$F'_c = \frac{0.30EC_T}{(l_e/d)^2}$$

### SECTION 2309 — COMPRESSION AT ANGLE TO GRAIN

The allowable unit stress in compression at an angle of load to grain between 0 degree and 90 degrees shall be computed from Hankinson's Formula as follows:

$$F_n = \frac{F_g' F_{c\perp}}{F_g' \sin^2 \theta + F_{c\perp} \cos^2 \theta}$$

Allowable values for end grain in bearing  $F_g'$  shall be adjusted for duration of load before use in Hankinson's Formula.  $F_g'$  values are tabulated in Division VIII. Values of  $F_n$  and  $F_{c\perp}$  are not subjected to duration of load modifications.

### SECTION 2310 — TENSION DESIGN

**2310.1 Tension Parallel to Grain.** The actual tension stress parallel to grain shall be based on the net section area and shall not exceed the allowable tension design value parallel to grain,  $f_t \leq F_t'$ .

**2310.2 Tension Perpendicular to Grain.** Where designs that induce tension stresses perpendicular to grain cannot be avoided, mechanical reinforcement sufficient to resist such forces shall be provided.

### SECTION 2311 — TIMBER CONNECTORS AND FASTENERS

**2311.1 General.** Timber connectors and fasteners may be used to transmit forces between wood members and between wood and metal members. The allowable loads and installation of timber connectors and fasteners shall be in accordance with the provisions set forth in Division III. For

connectors and fasteners where the wood is wet at time of fabrication or wet in service, the allowable loads shall be modified in accordance with Division III.

Safe loads and design practices for types of connectors and fasteners not mentioned or fully covered in Division III may be determined in a manner approved by the building official.

Fasteners for pressure-preservative-treated and fire-retardant-treated wood shall be of hot-dipped zinc-coated galvanized, stainless steel, silicon bronze or copper. Fasteners for wood foundations shall be as required in Chapter 18, Division II.

**EXCEPTION:** When approved, fasteners used in contact with preservative-treated wood products when not below grade or exposed to weather.

**2311.2 Bolts.** Safe loads in pounds for bolts in shear in seasoned lumber of Douglas fir-larch and southern pine shall not exceed the values set forth in Table 23-I-F. (For other species and wet conditions, see Division III.) Bolt diameters in wood connections shall be limited to a maximum 1 inch (25 mm) in diameter.

Allowable shear values used to connect a wood member to concrete or masonry are permitted to be determined as one half the tabulated double shear values for a wood member twice the thickness of the member attached to the concrete or masonry.

### **2311.3 Nails and Spikes.**

**2311.3.1 Safe lateral strength.** A common wire nail driven perpendicular to grain of the wood, when used to fasten wood members together, shall not be subjected to a greater load causing shear and bending than the safe lateral strength of the wire nail or spike as set forth in Table 23-I-G.

A wire nail driven parallel to the grain of the wood shall not be subjected to more than two thirds of the lateral load allowed when driven perpendicular to the grain. Toenails shall not be subjected to more than five sixths of the lateral load allowed for nails driven perpendicular to the grain.

**2311.3.2 Safe resistance to withdrawal.** A wire nail driven perpendicular to grain of the wood shall not be subjected to a greater load, tending to cause withdrawal, than the safe resistance of the nail to withdrawal, as set forth in Table 23-I-H.

Nails driven parallel to grain of the wood shall not be allowed for resisting withdrawal forces.

**2311.3.3 Spacing and penetration.** Common wire nails shall have penetration into the piece receiving the point as set forth in Table 23-I-G. Nails or spikes for which the wire gages or lengths are not set forth in Table 23-I-G shall have a required penetration of not less than 12 diameters, and allowable loads may be interpolated. Design values shall not be increased when the penetration of nails into the member holding the point is larger than required by this item.

For wood-to-wood joints, the spacing center to center of nails in the direction of stress shall not be less than the required penetration. Edge or end distances in the direction of stress shall not be less than one half of the required penetration. All spacing and edge and end distances shall be such as to avoid splitting of the wood.

Holes for nails, where necessary to prevent splitting, shall be bored of a diameter smaller than that of the nails.

**2311.4 Drift Bolts or Pins, Wood Screws and Lag Screws.** Connections involving the use of drift bolts or pins, wood screws and lag screws shall be designed in accordance with the provisions set forth in Division III.

**2311.5 Joist Hangers and Framing Anchors.** Connections depending on joist hangers or framing anchors, ties, and other mechanical fastenings not otherwise covered may be used where approved.

**2311.6 Metal Plate Connectors.** The material and workmanship during fabrication and the design of metal plate connectors employed as joint connectors for light wood trusses shall conform with the requirements of Division III.

Each truss manufacturer shall retain an approved agency having no financial interest in the plant being inspected to make nonscheduled inspections of truss fabrication and delivery and operations. The inspection shall cover all phases of truss operation, including lumber storage, handling, cutting, fixtures, presses or rollers, fabrication, bundling and banding, handling and delivery.

## SECTION 2312 — STRUCTURAL GLUED-LAMINATED TIMBER DESIGN

### 2312.1 General Provisions.

**2312.1.1 Design requirements.** Except as otherwise provided in this section, structural glued-laminated timber members shall be designed in accordance with the applicable engineering formulas used for sawn members.

**2312.1.2 Fastenings.** The pertinent provisions and allowable loads for fastenings given in this chapter shall apply to structural glued-laminated timber members.

**2312.1.3 Allowable unit stresses.** The allowable unit stresses for structural glued-laminated timber shall be in accordance with Tables 23-I-C-1, 23-I-C-2 and 23-I-D and as modified by this section.

**2312.2 Standard Sizes.** Laminated members shall be of standard finished widths.

Depth of straight and curved members, length of all members and net dimensions shall be specified on the plans.

**2312.3 Specifications.** For structural glued-laminated timber, the following shall be specified on the plans:

Whether for dry or wet conditions of use

Species and applicable standard

Stress requirements

If the temperature of the timber exceeds 150°F. (66°C.) in service

### 2312.4 Design Stresses.

**2312.4.1 Dry conditions of use.** Allowable stress values for dry conditions of use shall be applicable for normal loading when the moisture content in service is less than 16 percent, as in most covered structures.

**2312.4.2 Wet conditions of use.** Allowable stress values for wet conditions of use shall be applicable for normal loading when the moisture content in service is 16 percent or more, as may occur in exterior and submerged construction.

**2312.4.3 Curvature factor.** For the curved portion of members, the allowable unit stress in bending shall be modified by multiplication by the following curvature factor:

$$C_c = 1 - 2,000 \left( \frac{t}{R} \right)^2$$

#### WHERE:

$R$  = radius of curvature of inside face of lamination in inches, and  $t/R$  shall not exceed  $1/100$  for hardwoods and southern pine, or  $1/125$  for other softwoods.

$t$  = thickness of lamination in inches (mm).

No curvature factor shall be applied to stress in the straight portion of an assembly, regardless of curvature elsewhere.

**2312.4.4 Radial tension or compression.** The maximum radial stress induced in a curved member of constant rectangular cross section by a bending moment is:

$$f_r = \frac{3M}{2Rbd}$$

**WHERE:**

- $b$  = width of cross section in inches (mm).
- $d$  = depth of cross section in inches (mm).
- $f_r$  = radial stress in pounds per square inch (N/mm<sup>2</sup>).
- $M$  = bending moment in inch-pounds (N·mm).
- $R$  = radius of curvature at center line of member in inches (mm).

For curved bending members having a varying cross section, the maximum radial stress induced,  $f_r$ , is given by:

$$f_r = K_r \frac{6M}{bd^2}$$

**WHERE:**

- $b$  = width of cross section, inches (mm).
- $d$  = depth of cross section at the apex in inches (mm).
- $K_r$  = radial stress factor determined from the following relationship:

$$K_r = A + B \left( \frac{d}{Rm} \right) + C \left( \frac{d}{Rm} \right)^2$$

- $M$  = bending moment at midspan in inch-pounds (N·mm).

**WHERE:**

- $Rm$  = radius of curvature at the center line of the member at midspan in inches (mm).
- $A$ ,  $B$  and  $C$  = constants as follows:

$\beta$ (1)	$A$ (2)	$B$ (3)	$C$ (4)
(0.0)	(0.0)	(0.2500)	(0.0)
2.5°	0.0079	0.1747	0.1284
5.0°	0.0174	0.1251	0.1939
7.5°	0.0279	0.0937	0.2162
10.0°	0.0391	0.0754	0.2119
15.0°	0.0629	0.0619	0.1722
20.0°	0.0893	0.0608	0.1393
25.0°	0.1214	0.0605	0.1238
30.0°	0.1649	0.0603	0.1115

and  $\beta$  = angle between the upper edge of the member and the horizontal in degrees.

Values of  $K_r$  for intermediate values of  $\beta$  may be interpolated linearly.

When  $M$  is in the direction tending to decrease the curvature (increase the radius), the stress in tension across the grain ( $F_{rt}$ ) is limited to:

1. One third the allowable unit stress in horizontal shear of all species for wind and earthquake loads.
2. Fifteen pounds per square inch (psi) (103.4 kPa) for Douglas fir, larch, hem-fir, western woods and other softwoods for other types of loading.
3. One third the allowable unit stress in horizontal shear for southern pine, redwood and hardwoods for all types of loading.

These values are subject to modification for duration of load. If these values are exceeded, mechanical reinforcing sufficient to resist all radial tension stresses is required, but in no case shall the

calculated radial tension stress exceed one third the allowable unit stress in horizontal shear. When mechanical reinforcing is used, the maximum moisture content of the laminations at time of manufacture shall not exceed 12 percent for dry conditions of use.

When  $M$  is in the direction tending to increase curvature (decrease the radius), the radial stress is in compression and shall be limited to the allowable stress in compression perpendicular to the grain.

When the beam is loaded with a uniform load,  $K_r$  may be modified by multiplying by the reduction factor  $C_r$  as calculated by the following formula:

$$C_r = A + B \left( \frac{L}{L_t} \right) + C \left( \frac{d_c}{R_m} \right) + D \left( \frac{L}{L_t} \right)^2 + E \left( \frac{d_c}{R_m} \right)^2 + F \left( \frac{d_c}{R_m} \right) \left( \frac{L}{L_t} \right) + G \left( \frac{L}{L_t} \right)^3 + H \left( \frac{d_c}{R_m} \right)^3$$

**WHERE:**

- $C_r$  = reduction factor.
- $L$  = span of beam.
- $L_t$  = length of beam between tangent points.
- $A, B, \dots H$  = constants for a given  $\beta$  as follows:

$\beta$	A	B	C	D	E	F	G	H
2.3°	-.142	.418	-2.358	-.053	—	—	.002	—
9.7°	.143	.376	-.541	-.060	—	—	.003	—
14.9°	.406	.293	-.927	-.041	—	—	.002	—
20.0°	.423	.364	-1.022	-.067	—	.146	—	—
25.2°	.540	.360	-1.061	-.070	—	.156	—	—
29.8°	.502	.372	—	-.076	-3.712	.138	.004	4.336

and  $\beta$  = angle between the upper edge of the member and the horizontal in degrees. Values of  $C_r$  for intermediate values may be interpolated linearly.

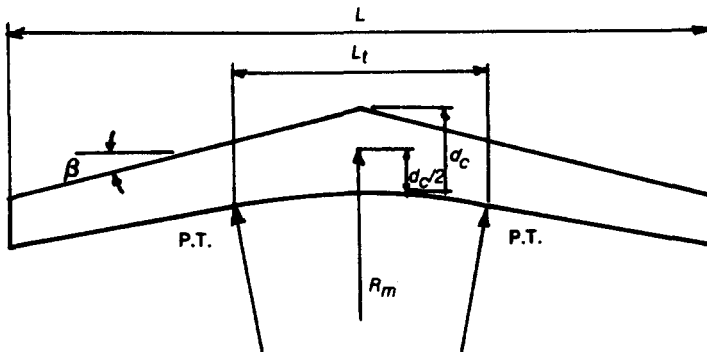

**PITCHED AND TAPERED CURVED BEAM**

**2312.4.5 Volume factor for beams.** When the size of a rectangular horizontally laminated glued-laminated timber beam is other than 5<sup>1</sup>/<sub>8</sub> inches (130 mm) in width, 12 inches (305 mm) in depth, with a span of 21 feet (6401 mm), the allowable unit stress in bending,  $F_b$ , shall be multiplied by the volume factor as determined by the following formula:

$$C_V = k (12/d)^{1/x} (5.125/b)^{1/y} (21/L)^{1/z} \leq 1.0$$

For SI: 
$$C_V = k \left(\frac{305}{d}\right)^{1/x} \left(\frac{130}{b}\right)^{1/y} \left(\frac{6401}{L}\right)^{1/z} \leq 1.0$$

**WHERE:**

- $b$  = the width of the member in inches (mm), which need not exceed 10<sup>3</sup>/<sub>4</sub> inches (273 mm) for these calculations.
- $C_V$  = volume factor, less than or equal to one, i.e., no increase is taken when the calculated value of  $C_V$  is greater than one.
- $d$  = the depth of the member in inches (mm).
- $k$  = factor to account for loading condition for simple span beams as given in the table below:
- $L$  = the length of the member in feet (mm) where  $L$  is determined as the distance between points of zero moment.
- $x = y = z = 10$  for western species.
- $x = y = z = 20$  for southern pine.

LOADING CONDITION	ADJUSTMENT FACTOR (k)
Concentrated loads located at one-third points of span	0.96
Uniformly distributed	1.00
Single concentrated load at midspan	1.09
Cantilevered beams or beams continuous over an intermediate support	1.00

**2312.4.6 Ponding.** Roof-framing members shall be designed for the deflection criteria and ponding requirements specified in Sections 1605.6 and 1607. In no case shall the roof slope provide a positive vertical displacement less than that equivalent to 1/4 unit vertical in 12 units horizontal (2% slope) of horizontal distance between the level of the drain and the high point of the roof for drainage. Such slope shall be in addition to the camber in glued-laminated timbers of one and one-half times the calculated dead load deflection. The calculation of the required slope shall not include any vertical displacement created by short taper cuts.

Roofs having insufficient slope for drainage shall be investigated by a rational analysis to assure stability under ponding conditions, but in no case shall the deflection of such glued-laminated timbers exceed 1/2 inch (13 mm) for a 5-pound-per-square-foot (239 Pa) uniform load.

**2312.5 Tapered Faces.** Sawn tapered cuts shall not be permitted on the tension face of any beam. Pitched or curved beams shall be so fabricated that the laminations are parallel to the tension face. Straight, pitched or curved beams may have sawn tapered cuts on the compression face.

For other members subject to bending, the slope of tapered faces, measured from the tangent to the lamination of the section under consideration, shall not be steeper than 1 unit vertical in 24 units horizontal (4% slope) on the tension side.

**EXCEPTIONS:** 1. This requirement shall not apply to arches.

2. Taper may be steeper at sections increased in size beyond design requirements for architectural projections.

**2312.6 Manufacture and Fabrication.** The manufacture and fabrication of structural glued-laminated timber shall be under the supervision of qualified personnel.

**2312.7 Exposed Structural Glued-laminated Timber.** Those portions of glued-laminated timbers which form the structural supports of a building or other structure and are exposed to weather and not properly protected by a roof, eave overhangs or similar covering shall be pressure treated with an approved preservative or be manufactured from wood of natural resistance to decay.

## SECTION 2313 — DESIGN OF GLUED BUILT-UP MEMBERS

Plywood components shall be designed, fabricated and identified in accordance with Division IV.

## SECTION 2314 — WOOD SHEAR WALLS AND DIAPHRAGMS

**2314.1 General.** Lumber, wood structural panel and particleboard diaphragms may be used to resist horizontal forces in horizontal and vertical distributing or resisting elements, provided the deflection in the plane of the diaphragm, as determined by calculations, tests or analogies drawn therefrom, does not exceed the permissible deflection of attached distributing or resisting elements. See U.B.C. Standard 23-2 for a method of calculating the deflection of a blocked wood structural panel diaphragm.

Permissible deflection shall be that deflection up to which the diaphragm and any attached distributing or resisting element will maintain its structural integrity under assumed load conditions, i.e., continue to support assumed loads without danger to occupants of the structure.

Connections and anchorages capable of resisting the design forces shall be provided between the diaphragms and the resisting elements. Openings in diaphragms which materially affect their strength shall be fully detailed on the plans and shall have their edges adequately reinforced to transfer all shearing stresses.

Size and shape of diaphragms shall be limited as set forth in Table 23-I-I.

In buildings of wood-frame construction where rotation is provided for, the depth of the diaphragm normal to the open side shall not exceed 25 feet (7620 mm) or two thirds the diaphragm width, whichever is the smaller depth. Straight sheathing shall not be permitted to resist shears in diaphragms acting in rotation.

**EXCEPTIONS:** 1. One-story, wood-framed structures with the depth normal to the open side not greater than 25 feet (7620 mm) may have a depth equal to the width.

2. Where calculations show that diaphragm deflections can be tolerated, the depth normal to the open end may be increased to a depth-to-width ratio not greater than 1<sup>1</sup>/<sub>2</sub>:1 for diagonal sheathing or 2:1 for special diagonal sheathed or wood structural panel or particleboard diaphragms.

In masonry or concrete buildings, lumber, wood structural panel and particleboard diaphragms shall not be considered as transmitting lateral forces by rotation.

Diaphragm sheathing nails or other approved sheathing connectors shall be driven flush but shall not fracture the surface of the sheathing.

### 2314.2 Diagonally Sheathed Diaphragms.

**2314.2.1 Conventional construction.** Such lumber diaphragms shall be made up of 1-inch (25 mm) nominal sheathing boards laid at an angle of approximately 45 degrees to supports. Sheathing boards shall be directly nailed to each intermediate bearing member with not less than two 8d nails for 1-inch by 6-inch (25 mm by 152 mm) nominal boards and three 8d nails for boards 8 inches (203 mm) or wider; and, in addition, three 8d nails and four 8d nails shall be used for 6-inch and 8-inch (152 mm and 203 mm) boards, respectively, at the diaphragm boundaries. End joints in adjacent boards shall be separated by at least one joist or stud space, and there shall be at least two boards between joints on the same support. Boundary members at edges of diaphragms shall be designed to resist direct tensile or compressive chord stresses and shall be adequately tied together at corners.

Conventional lumber diaphragms of Douglas fir-larch or southern pine may be used to resist shear due to wind or seismic forces not exceeding 300 pounds per lineal foot (4.37 kN/m) of width.

The allowable strength shall be adjusted by the factors 0.82 and 0.65 where nails are used with sheathing and framing of Group III or IV wood species as listed in Table 23-III-J of Division III.

**2314.2.2 Special construction.** Special diagonally sheathed diaphragms shall conform to conventional construction and, in addition, shall have all elements designed in conformance with the provisions of this code.

Each chord or portion thereof may be considered as a beam loaded with a uniform load per foot equal to 50 percent of the unit shear due to diaphragm action. The load shall be assumed as acting normal to the chord, in the plane of the diaphragm and either toward or away from the diaphragm. The span of the chord, or portion thereof, shall be the distance between structural members of the diaphragm, such as the joists, studs and blocking, which serve to transfer the assumed load to the sheathing.

Special diagonally sheathed diaphragms shall include conventional diaphragms sheathed with two layers of diagonal sheathing at 90 degrees to each other and on the same face of the supporting members.

Special diagonally sheathed diaphragms of Douglas fir-larch or southern pine may be used to resist shears due to wind or seismic loads, provided such shears do not stress the nails beyond their allowable safe lateral strength and do not exceed 600 pounds per lineal foot (8.75 kN/m) of width. The allowable strength shall be adjusted by the factors 0.82 and 0.65 where nails are used with sheathing and framing of Group III or IV wood species as listed in Table 23-III-J of Division III.

**2314.3 Wood Structural Panel Diaphragms.** Horizontal and vertical diaphragms sheathed with wood structural panels may be used to resist horizontal forces not exceeding those set forth in Table 23-I-J-1 for horizontal diaphragms and Table 23-I-K-1 for vertical diaphragms, or may be calculated by principles of mechanics without limitation by using values of nail strength and wood structural panel shear values as specified elsewhere in this code. Wood structural panels for horizontal diaphragms shall be as set forth in Tables 23-I-S-1 and 23-I-S-2 for corresponding joist spacing and loads. Wood structural panels in shear walls shall be at least  $\frac{5}{16}$  inch (7.9 mm) thick for studs spaced 16 inches (406 mm) on center and  $\frac{3}{8}$  inch (9.5 mm) thick where studs are spaced 24 inches (610 mm) on center.

Maximum spans for wood structural panel subfloor underlayment shall be as set forth in Table 23-I-T-1. Wood structural panels used for horizontal and vertical diaphragms shall conform to U.B.C. Standard 23-2 or 23-3.

All boundary members shall be proportioned and spliced where necessary to transmit direct stresses. Framing members shall be at least 2-inch (51 mm) nominal in the dimension to which the wood structural panel is attached. In general, panel edges shall bear on the framing members and butt along their center lines. Nails shall be placed not less than  $\frac{3}{8}$  inch (9.5 mm) in from the panel edge, shall be spaced not more than 6 inches (152 mm) on center along panel edge bearings, and shall be firmly driven into the framing members. No unblocked panels less than 12 inches (305 mm) wide shall be used.

Where the wood structural panel is applied on both faces of a shear wall in accordance with Table 23-I-K-1, allowable shear for the wall may be taken as twice the tabulated shear for one side, except that where the shear capacities are not equal, the allowable shear shall be either the shear for the side with the higher capacity or twice the shear for the side with the lower capacity, whichever is greater.

Diaphragms with panel edges supported in accordance with Tables 23-I-S-1, 23-I-S-2 and 23-I-T-1 shall not be considered as blocked diaphragms unless blocking or other means of shear transfer is provided.

**2314.4 Particleboard Diaphragms.** Horizontal and vertical diaphragms sheathed with particleboard may be used to resist horizontal forces not exceeding those set forth in Table 23-I-J-2 for horizontal diaphragms and Table 23-I-K-2 for vertical diaphragms.

All boundary members shall be proportioned and spliced where necessary to transmit direct stresses. Framing members shall be at least 2-inch (51 mm) nominal in the dimension to which the

particleboard is attached. In general, panel edges shall bear on the framing members and butt along their center lines. Nails shall be placed not less than  $\frac{3}{8}$  inch (9.5 mm) in from the panel edge, shall be spaced not more than 6 inches (152 mm) on center along panel edge bearings, and shall be firmly driven into the framing members. No unblocked panels less than 12 inches (305 mm) wide shall be used.

Diaphragms with panel edges supported in accordance with Tables 23-I-S-3 and 23-I-T-2 shall not be considered as blocked diaphragms unless blocking or other means of shear transfer is provided.

#### **2314.5 Wood Shear Walls and Diaphragms in Seismic Zones 3 and 4.**

**2314.5.1 Scope.** Design and construction of wood shear walls and diaphragms in Seismic Zones 3 and 4 shall conform to the requirements of this section.

**2314.5.2 Framing.** Collector members shall be provided to transmit tension and compression forces. Perimeter members at openings shall be provided and shall be detailed to distribute the shearing stresses. Diaphragm sheathing shall not be used to splice these members.

Diaphragm chords and ties shall be placed in, or tangent to, the plane of the diaphragm framing unless it can be demonstrated that the moments, shears and deflections and deformations resulting from other arrangements can be tolerated.

**2314.5.3 Wood structural panels.** Wood structural panels shall be manufactured using exterior glue.

Wood structural panel diaphragms and shear walls shall be constructed with wood structural panel sheets not less than 4 feet by 8 feet (1219 mm by 2438 mm), except at boundaries and changes in framing where minimum sheet dimension shall be 24 inches (610 mm) unless all edges of the undersized sheets are supported by framing members or blocking.

Framing members or blocking shall be provided at the edges of all sheets in shear walls.

Wood structural panel sheathing may be used for splicing members, other than those noted in Section 2314.5.2, where the additional nailing required to develop the transfer of forces will not cause cross-grain bending or cross-grain tension in the nailed member.

**2314.5.4 Heavy wood panels.** Diagonally sheathed panels utilizing 2-inch (51 mm) nominal boards may be used to resist the same permissible shears as 1-inch (25 mm) nominal lumber, except that 16d nails shall be used instead of 8d.

Panels utilizing straight decking overlaid with wood structural panels may be used to resist shear forces using the same shear values as permitted for the wood structural panel alone. Wood structural panel joints parallel to the decking shall be located at least 1 inch (25 mm) offset from any parallel decking joint.

Heavy decking panels utilizing dowel pins, or vertically laminated panels connected by nailing units to one another, resist shear forces based on the permissible shear values of their connectors.

**2314.5.5 Particleboard.** Particleboard shall not be less than Grade 2-M-W using exterior glue.

Particleboard diaphragms and shear walls shall be constructed of sheets not less than 4 feet by 8 feet (1219 mm by 2438 mm) except at boundaries and changes in framing where minimum sheet dimension shall be 24 inches (610 mm) unless all edges of the undersized sheets are supported by framing members or blocking.

Framing members or blocking shall be provided at the edges of all sheets in shear walls.

### **SECTION 2315 — FIBERBOARD SHEATHING DIAPHRAGMS**

Wood stud walls sheathed with fiberboard sheathing may be used to resist horizontal forces not exceeding those set forth in Table 23-I-P. The fiberboard sheathing, 4 feet by 8 feet (1219 mm by 2438

mm), shall be applied vertically to wood studs not less than 2-inch (51 mm) nominal in thickness spaced 16 inches (406 mm) on center. Nailing shown in Table 23-I-P shall be provided at the perimeter of the sheathing board and at intermediate studs. Blocking not less than 2-inch (51 mm) nominal in thickness shall be provided at horizontal joints when wall height exceeds length of sheathing panel, and sheathing shall be fastened to the blocking with nails sized as shown in Table 23-I-P spaced 3 inches (76 mm) on centers each side of joint. Nails shall be spaced not less than  $\frac{3}{8}$  inch (9.5 mm) from edges and ends of sheathing. Marginal studs of shear walls or shear-resisting elements shall be adequately anchored at top and bottom and designed to resist all forces. The maximum height-width ratio shall be 1 $\frac{1}{2}$ :1.

## SECTION 2316 — WOOD COMBINED WITH MASONRY OR CONCRETE

**2316.1 Dead Load.** Wood members shall not be used to permanently support the dead load of any masonry or concrete.

**EXCEPTIONS:** 1. Masonry or concrete nonstructural floor or roof surfacing not more than 4 inches (102 mm) thick may be supported by wood members.

2. Any structure may rest upon wood piles constructed in accordance with the requirements of Chapter 18.

3. Veneer of brick, concrete or stone applied as specified in Section 1403.6.2 may be supported by approved treated wood foundations when the maximum height of veneer does not exceed 30 feet (9144 mm) above the foundation. Such veneer used as an interior wall finish may also be supported on wood floors which are designed to support the additional load, and be designed to limit the deflection and shrinkage to  $\frac{1}{600}$  of the span of the supporting members.

4. Glass block masonry having an installed weight of 20 pounds per square foot (97.6 kg/m<sup>2</sup>) or less and installed with the provisions of Section 2109.5. When glass block is supported on wood floors, the floors shall be designed to limit deflection and shrinkage to  $\frac{1}{600}$  of the span of the supporting members and the allowable stresses for the framing members shall be reduced in accordance with Section 2304.3.4, item 1.

**2316.2 Horizontal Force.** Wood members shall not be used to resist horizontal forces contributed by masonry or concrete construction in buildings over one story in height.

**EXCEPTIONS:** 1. Wood floor and roof members may be used in horizontal trusses and diaphragms to resist horizontal forces imposed by wind, earthquake or earth pressure, provided such forces are not resisted by rotation of the truss or diaphragm. See Section 2314.1.

2. Vertical wood structural panel-sheathed shear walls may be used to provide resistance to wind or earthquake forces in two-story buildings of masonry or concrete construction, provided the following requirements are met:

2.1 Story-to-story wall heights shall not exceed 12 feet (3658 mm).

2.2 Horizontal diaphragms shall not be considered to transmit lateral forces by rotation or cantilever action.

2.3 Deflections of horizontal and vertical diaphragms shall not permit per-story deflections of supported masonry or concrete walls to exceed 0.005 times each story height.

2.4 Wood structural panel sheathing in horizontal diaphragms shall have all unsupported edges blocked. Wood structural panel sheathing for both stories of vertical diaphragms shall have all unsupported edges blocked and for the lower story walls shall have a minimum thickness of  $\frac{15}{32}$  inch (12 mm).

2.5 There shall be no out-of-plane horizontal offsets between the first and second stories of wood structural panel shear walls.

## SECTION 2317 — DECAY AND TERMITE PROTECTION

**2317.1 Preparation of Building Site.** Site preparation shall be in accordance with Section 3302.

**2317.2 Wood Support Embedded in Ground.** Wood embedded in the ground or in direct contact with the earth and used for the support of permanent structures shall be treated wood unless continuously below the groundwater line or continuously submerged in fresh water. Round or rectangular posts, poles and sawn timber columns supporting permanent structures which are em-

bedded in concrete or masonry in direct contact with earth or embedded in concrete or masonry exposed to the weather shall be treated wood. The wood shall be treated for ground contact.

**2317.3 Under-floor Clearance.** When wood joists or the bottom of wood structural floors without joists are located closer than 18 inches (457 mm) or wood girders are located closer than 12 inches (305 mm) to exposed ground in crawl spaces or unexcavated areas located within the periphery of the building foundation, the floor assembly, including posts, girders, joists and subfloor, shall be approved wood of natural resistance to decay as listed in Section 2317.4 or treated wood.

When the above under-floor clearances are required, the under-floor area shall be accessible. Accessible under-floor areas shall be provided with a minimum 18-inch by 24-inch (457 mm by 610 mm) opening unobstructed by pipes, ducts and similar construction. All under-floor access openings shall be effectively screened or covered. Pipes, ducts and other construction shall not interfere with the accessibility to or within under-floor areas.

**2317.4 Plates, Sills and Sleepers.** All foundation plates or sills and sleepers on a concrete or masonry slab, which is in direct contact with earth, and sills which rest on concrete or masonry foundations, shall be treated wood or Foundation redwood, all marked or branded by an approved agency. Foundation cedar or No. 2 Foundation redwood marked or branded by an approved agency may be used for sills in territories subject to moderate hazard, where termite damage is not frequent and when specifically approved by the building official. In territories where hazard of termite damage is slight, any species of wood permitted by this code may be used for sills when specifically approved by the building official.

**2317.5 Columns and Posts.** Columns and posts located on concrete or masonry floors or decks exposed to the weather or to water splash or in basements and which support permanent structures shall be supported by concrete piers or metal pedestals projecting above floors unless approved wood of natural resistance to decay or treated wood is used. The pedestals shall project at least 6 inches (152 mm) above exposed earth and at least 1 inch (25 mm) above such floors.

Individual concrete or masonry piers shall project at least 8 inches (203 mm) above exposed ground unless the columns or posts which they support are of approved wood of natural resistance to decay or treated wood is used.

**2317.6 Girders Entering Masonry or Concrete Walls.** Ends of wood girders entering masonry or concrete walls shall be provided with a  $\frac{1}{2}$ -inch (13 mm) air space on tops, sides and ends unless approved wood of natural resistance to decay or treated wood is used.

**2317.7 Under-floor Ventilation.** Under-floor areas shall be ventilated by an approved mechanical means or by openings into the under-floor area walls. Such openings shall have a net area of not less than 1 square foot for each 150 square feet (0.067m<sup>2</sup> for each 10m<sup>2</sup>) of under-floor area. Openings shall be located as close to corners as practical and shall provide cross ventilation. The required area of such openings shall be approximately equally distributed along the length of at least two opposite sides. They shall be covered with corrosion-resistant wire mesh with mesh openings of  $\frac{1}{4}$  inch (6.4 mm) in dimension. Where moisture due to climate and groundwater conditions is not considered excessive, the building official may allow operable louvers and may allow the required net area of vent openings to be reduced to 10 percent of the above, provided the under-floor ground surface area is covered with an approved vapor retarder.

**2317.8 Wood and Earth Separation.** Protection of wood against deterioration as set forth in the previous paragraphs for specified applications is required. In addition, wood used in construction of permanent structures and located nearer than 6 inches (152 mm) to earth shall be treated wood or wood of natural resistance to decay, as defined in Section 2302.1. Where located on concrete slabs placed on earth, wood shall be treated wood or wood of natural resistance to decay. Where not subject to water splash or to exterior moisture and located on concrete having a minimum thickness of 3 inches (76 mm) with an impervious membrane installed between concrete and earth, the wood may be untreated and of any species.

Where planter boxes are installed adjacent to wood frame walls, a 2-inch-wide (51 mm) air space shall be provided between the planter and the wall. Flashings shall be installed when the air space is less than 6 inches (152 mm) in width. Where flashing is used, provisions shall be made to permit circulation of air in the air space. The wood-frame wall shall be provided with an exterior wall covering conforming to the provisions of Section 2320.

**2317.9 Wood Supporting Roofs and Floors.** Wood structural members supporting moisture-permeable floors or roofs which are exposed to the weather, such as concrete or masonry slabs, shall be approved wood of natural resistance to decay or treated wood unless separated from such floors or roofs by an impervious moisture barrier.

**2317.10 Moisture Content of Treated Wood.** When wood pressure treated with a water-borne preservative is used in enclosed locations where drying in service cannot readily occur, such wood shall be at a moisture content of 19 percent or less before being covered with insulation, interior wall finish, floor covering or other material.

**2317.11 Retaining Walls.** Wood used in retaining or crib walls shall be treated wood.

**2317.12 Weather Exposure.** In geographical areas where experience has demonstrated a specific need, approved wood of natural resistance to decay or treated wood shall be used for those portions of wood members which form the structural supports of buildings, balconies, porches or similar permanent building appurtenances when such members are exposed to the weather without adequate protection from a roof, eave, overhang or other covering to prevent moisture or water accumulation on the surface or at joints between members. Depending on local experience, such members may include horizontal members such as girders, joists and decking; or vertical members such as posts, poles and columns; or both horizontal and vertical members.

**2317.13 Water Splash.** Where wood-frame walls and partitions are covered on the interior with plaster, tile or similar materials and are subject to water splash, the framing shall be protected with approved waterproof paper conforming to Section 1402.1.

## SECTION 2318 — WALL FRAMING

The framing of exterior and interior walls shall be in accordance with provisions specified in Section 2326 unless a specific design is furnished.

Wood stud walls and bearing partitions shall not support more than two floors and a roof unless an analysis satisfactory to the building official shows that shrinkage of the wood framing will not have adverse effects on the structure or any plumbing, electrical or mechanical systems, or other equipment installed therein due to excessive shrinkage or differential movements caused by shrinkage. The analysis shall also show that the roof drainage system and the foregoing systems or equipment will not be adversely affected or, as an alternate, such systems shall be designed to accommodate the differential shrinkage or movements.

## SECTION 2319 — FLOOR FRAMING

Wood-joisted floors shall be framed and constructed and anchored to supporting wood stud or masonry walls as specified in Chapter 16.

Fire block and draft stops shall be in accordance with Section 708.

## SECTION 2320 — EXTERIOR WALL COVERINGS

**2320.1 General.** Exterior wood stud walls shall be covered on the outside with the materials and in the manner specified in this section or elsewhere in this code. Studs or sheathing shall be covered on the outside face with a weather-resistive barrier when required by Section 1402.1. Exterior wall

coverings of the minimum thickness specified in this section are based on a maximum stud spacing of 16 inches (406 mm) unless otherwise specified.

**2320.2 Siding.** Solid wood siding shall have an average thickness of  $\frac{3}{8}$  inch (9.5 mm) unless placed over sheathing permitted by this code.

Siding patterns known as rustic, drop siding or shiplap shall have an average thickness in place of not less than  $\frac{19}{32}$  inch (15 mm) and shall have a minimum thickness of not less than  $\frac{3}{8}$  inch (9.5 mm). Bevel siding shall have a minimum thickness measured at the butt section of not less than  $\frac{7}{16}$  inch (11 mm) and a tip thickness of not less than  $\frac{3}{16}$  inch (4.8 mm). Siding of lesser dimensions may be used, provided such wall covering is placed over sheathing which conforms to the provisions specified elsewhere in this code.

All weatherboarding or siding shall be securely nailed to each stud with not less than one nail, or to solid 1-inch (25 mm) nominal wood sheathing or  $\frac{15}{32}$ -inch (12 mm) wood structural panel sheathing or  $\frac{1}{2}$ -inch (13 mm) particleboard sheathing with not less than one line of nails spaced not more than 24 inches (610 mm) on center in each piece of the weatherboarding or siding.

Wood board sidings applied horizontally, diagonally or vertically shall be fastened to studs, nailing strips or blocking set at a maximum 24 inches (610 mm) on center. Fasteners shall be nails or screws with a penetration of not less than  $1\frac{1}{2}$  inches (38 mm) into studs, studs and wood sheathing combined, or blocking. Distance between such fastenings shall not exceed 24 inches (610 mm) for horizontally or vertically applied sidings and 32 inches (813 mm) for diagonally applied sidings.

**2320.3 Plywood.** When plywood is used for covering the exterior of outside walls, it shall be of the exterior type not less than  $\frac{3}{8}$  inch (9.5 mm) thick. Plywood panel siding shall be installed in accordance with Table 23-I-M-1. Unless applied over 1-inch (25 mm) wood sheathing or  $\frac{15}{32}$ -inch (12 mm) wood structural panel sheathing or  $\frac{1}{2}$ -inch (13 mm) particleboard sheathing, joints shall occur over framing members and shall be protected with a continuous wood batten, approved caulking, flashing, vertical or horizontal shiplaps; or joints shall be lapped horizontally or otherwise made waterproof.

**2320.4 Shingles or Shakes.** Wood shingles or shakes and asbestos cement shingles may be used for exterior wall covering, provided the frame of the structure is covered with building paper as specified in Section 1402.1. All shingles or shakes attached to sheathing other than wood sheathing shall be secured with approved corrosion-resistant fasteners or on furring strips attached to the studs. Wood shingles or shakes may be applied over fiberboard shingle backer and sheathing with annular grooved nails. The thickness of wood shingles or shakes between wood nailing boards shall not be less than  $\frac{3}{8}$  inch (9.5 mm). Wood shingles or shakes and asbestos shingles or siding may be nailed directly to approved fiberboard nailbase sheathing not less than  $\frac{1}{2}$ -inch (13 mm) nominal thickness with annular grooved nails.

The weather exposure of wood shingle or shake siding used on exterior walls shall not exceed maximums set forth in Table 23-I-L.

**2320.5 Particleboard.** When particleboard is used for covering the exterior of outside walls it shall be of the Exterior Type 2-M grades conforming to U.B.C. Standard 23-4. Particleboard panel siding shall be installed in accordance with Table 23-I-M-2 and Table 23-I-Q. Panels shall be gapped  $\frac{1}{8}$  inch (3.2 mm) and nails shall be spaced not less than  $\frac{3}{8}$  inch (9.5 mm) from edges and ends of sheathing. Unless applied over  $\frac{5}{8}$ -inch (16 mm) net wood sheathing; or  $\frac{1}{2}$ -inch (13 mm) plywood sheathing or  $\frac{1}{2}$ -inch (13 mm) particleboard sheathing, joints shall occur over framing members and shall be covered with a continuous wood batt; or joints shall be lapped horizontally or otherwise made waterproof to the satisfaction of the building official. Particleboard shall be sealed and protected with exterior quality finishes.

**2320.6 Hardboard.** When hardboard siding is used for covering the outside of exterior walls, it shall conform to Table 23-I-O. Lap siding shall be installed horizontally and applied to sheathed or unsheathed walls. Corner bracing shall be installed in conformance with Section 2326.11.3. A weather-resistive barrier shall be installed under the lap siding as required by Section 1402.1.

Square-edged nongrooved panels and shiplap grooved or nongrooved siding shall be applied vertically to sheathed or unsheathed walls. Siding that is grooved shall not be less than  $\frac{1}{4}$  inch (6.4 mm) thick in the groove.

Nail size and spacing shall follow Table 23-I-O and shall penetrate framing  $1\frac{1}{2}$  inches (38 mm). Lap siding shall overlap 1 inch (25 mm) minimum and be nailed through both courses and into framing members with nails located  $\frac{1}{2}$  inch (13 mm) from bottom of the overlapped course. Square-edged nongrooved panels shall be nailed  $\frac{3}{8}$  inch (9.5 mm) from the perimeter of the panel and intermediately into studs. Shiplap edge panel siding with  $\frac{3}{8}$ -inch (9.5 mm) shiplap shall be nailed  $\frac{3}{8}$  inch (9.5 mm) from the edges on both sides of the shiplap. The  $\frac{3}{4}$ -inch (19 mm) shiplap shall be nailed  $\frac{3}{8}$  inch (9.5 mm) from the edge and penetrate through both the overlap and underlap. Top and bottom edges of the panel shall be nailed  $\frac{3}{8}$  inch (9.5 mm) from the edge. Shiplap and lap siding shall not be force fit. Square-edged panels shall maintain a  $\frac{1}{16}$ -inch (1.6 mm) gap at joints. All joints and edges of siding shall be over framing members, and shall be made resistant to weather penetration with battens, horizontal overlaps or shiplaps to the satisfaction of the building official. A  $\frac{1}{8}$ -inch (3.2 mm) gap shall be provided around all openings.

**2320.7 Nailing.** All fasteners used for the attachment of siding shall be of a corrosion-resistant type.

## SECTION 2321 — INTERIOR PANELING

All softwood wood structural panels shall conform with the provisions of Chapter 8 and shall be installed in accordance with Table 23-I-Q. Panels shall comply with U.B.C. Standard 23-3.

## SECTION 2322 — SHEATHING

**2322.1 Structural Floor Sheathing.** Structural floor sheathing shall be designed in accordance with the general provisions of this code and the special provisions in this section

Sheathing used as subflooring shall be designed to support all loads specified in this code and shall be capable of supporting concentrated loads of not less than 300 pounds (1334 N) without failure. The concentrated load shall be applied by a loaded disc, 3 inches (76 mm) or smaller in diameter.

Flooring, including the finish floor, underlayment and subfloor, where used, shall meet the following requirements:

Deflection under uniform design load limited to  $\frac{1}{360}$  of the span between supporting joists or beams.

Deflection of flooring relative to joists under a 1-inch-diameter (25 mm) concentrated load of 200 pounds (890 N) limited to 0.125 inch (3.2 mm) or less when loaded midway between supporting joists or beams not over 24 inches (610 mm) on center and  $\frac{1}{360}$  of the span for spans over 24 inches (610 mm).

Floor sheathing conforming to the provisions of Table 23-I-R-1, 23-I-R-2, 23-I-S-1, 23-I-T-1 or 23-I-T-2 shall be deemed to meet the requirements of this section.

**2322.2 Structural Roof Sheathing.** Structural roof sheathing shall be designed in accordance with the general provisions of this code and the special provisions in this section. Structural roof sheathing shall be designed to support all loads specified in this code and shall be capable of supporting concentrated loads of not less than 300 pounds (1334 N) without failure. The concentrated load shall be applied by a loaded disc, 3 inches (76 mm) or smaller in diameter. Structural roof sheathing shall meet the following requirement:

Deflection under uniform design live and dead load limited to  $\frac{1}{180}$  of the span between supporting rafters or beams and  $\frac{1}{240}$  under live load only.

Roof sheathing conforming to the provisions of Tables 23-I-R-1 and 23-I-R-2 or 23-I-S-1 and 23-I-S-2 or 23-I-S-3 shall be deemed to meet the requirements of this section.

Wood structural panel roof sheathing shall be bonded by intermediate or exterior glue. Wood structural panel roof sheathing exposed on the underside shall be bonded with exterior glue.

### SECTION 2323 — MECHANICALLY LAMINATED FLOORS AND DECKS

A laminated lumber floor or deck built up of wood members set on edge, when meeting the following requirements, may be designed as a solid floor or roof deck of the same thickness, and continuous spans may be designed on the basis of the full cross section using the simple span moment coefficient.

Nail length shall not be less than two and one-half times the net thickness of each lamination. When deck supports are 4 feet (1219 mm) on center or less, side nails shall be spaced not more than 30 inches (762 mm) on center and staggered one third of the spacing in adjacent laminations. When supports are spaced more than 4 feet (1219 mm) on center, side nails shall be spaced not more than 18 inches (457 mm) on center alternately near top and bottom edges, and also staggered one third of the spacing in adjacent laminations. Two side nails shall be used at each end of butt-jointed pieces.

Laminations shall be toenailed to supports with 20d or larger common nails. When the supports are 4 feet (1219 mm) on center or less, alternate laminations shall be toenailed to alternate supports; when supports are spaced more than 4 feet (1219 mm) on center, alternate laminations shall be toenailed to every support.

A single-span deck shall have all laminations full length.

A continuous deck of two spans shall not have more than every fourth lamination spliced within quarter points adjoining supports.

Joints shall be closely butted over supports or staggered across the deck but within the adjoining quarter spans.

No lamination shall be spliced more than twice in any span.

### SECTION 2324 — POST-BEAM CONNECTIONS

Where post and beam or girder construction is used, the design shall be in accordance with the provisions of this code. Positive connection shall be provided to ensure against uplift and lateral displacement.

### SECTION 2325 — FASTENINGS

**2325.1 Nailing Requirements.** The number and size of nails connecting wood members shall not be less than that set forth in Table 23-I-Q. Other connections shall be fastened so as to provide equivalent strength. End and edge distances and nail penetrations shall be in accordance with the applicable provisions of Section 2311. Fasteners required to be corrosion resistant shall be either zinc-coated fasteners, aluminum alloy wire fasteners or stainless steel fasteners.

**2325.2 Joist Hangers and Framing Anchors.** Connections depending on joist hangers or framing anchors, ties and other mechanical fastenings not otherwise covered may be used where approved.

### SECTION 2326 — CONVENTIONAL LIGHT-FRAME CONSTRUCTION PROVISIONS

**2326.1 General.** The requirements in this section are intended for conventional, light-frame construction. Other methods may be used provided a satisfactory design is submitted showing compliance with other provisions of this code.

Only the following occupancies may be constructed in accordance with Section 2326:

1. One-, two- or three-story buildings housing Group R Occupancies.
2. One-story Occupancy Category 4 buildings, as defined in Table 16-K, when constructed on a slab-on-grade floor.
3. Group U Occupancies.
4. Top-story walls and roofs of Occupancy Category 4 buildings not exceeding two stories of wood framing.
5. Interior nonload-bearing partitions, ceilings and curtain walls in all occupancies.

When total loads exceed those specified in Tables 23-I-V-J-1, 23-I-V-J-3, and 23-I-V-R-1, 23-I-V-R-2, 23-I-V-R-3, 23-I-V-R-4, 23-I-V-R-7, 23-I-V-R-8, 23-I-V-R-9, 23-I-V-R-10, 23-I-V-R-11 and 23-I-V-R-12; 23-V-R-1, 23-V-R-3, 23-V-R-7, 23-V-R-9, 23-VI-A, 23-VI-B, 23-VI-C, 23-VI-D, an engineering design shall be provided for the gravity load system.

Other approved repetitive wood members may be used in lieu of solid-sawn lumber in conventional construction provided these members comply with the provisions of this code.

**2326.2 Design of Portions.** When a building of otherwise conventional construction contains nonconventional structural elements, those elements shall be designed in accordance with Section 1603.3.

**2326.3 Additional Requirements for Conventional Construction in High-wind Areas.** Appendix Chapter 23 provisions for conventional construction in high-wind areas shall apply when specifically adopted.

**2326.4 Additional Requirements for Conventional Construction in Seismic Zones 0, 1, 2 and 3.**

**2326.4.1 Braced wall lines.** Where the basic wind speed is not greater than 80 miles per hour (mph) (129 km/h), buildings shall be provided with exterior and interior braced wall lines. Spacing shall not exceed 34 feet (10 363 mm) on center in both the longitudinal and transverse directions in each story.

**2326.4.2 Braced wall lines for high wind.** Where the basic wind speed exceeds 80 mph (129 km/h), buildings shall be provided with exterior and interior braced wall lines. Spacing shall not exceed 25 feet (7620 mm) on center in both the longitudinal and transverse directions in each story.

**EXCEPTION:** In one- and two-story Group R, Division 3 buildings, interior braced wall line spacing may be increased to not more than 34 feet (10 363 mm) on center in order to accommodate one single room per dwelling unit not exceeding 900 square feet (83.61 m<sup>2</sup>). The building official may require additional walls to contain braced panels when this exception is used.

**2326.4.3 Veneer.** Anchored masonry and stone wall veneer shall not exceed 5 inches (127 mm) in thickness and shall conform to the requirements of Chapter 14.

**2326.4.4 Unusually shaped buildings.** When of unusual shape as defined in Section 2326.5.4, buildings of light-frame construction located in Seismic Zone 3 shall have a lateral-force-resisting system designed to resist the forces specified in Chapter 16.

**2326.5 Additional Requirements for Conventional Construction in Seismic Zone 4.**

**2326.5.1 Braced wall lines.** Buildings shall be provided with exterior and interior braced wall lines. Spacing shall not exceed 25 feet (7620 mm) on center in both the longitudinal and transverse directions in each story.

**EXCEPTION:** In one- and two-story Group R, Division 3 buildings, interior braced wall line spacing may be increased to not more than 34 feet (10 363 mm) on center in order to accommodate one single room per dwelling unit not exceeding 900 square feet (83.61 m<sup>2</sup>). The building official may require additional walls to contain braced panels when this exception is used.

**2326.5.2 Lateral-force-resisting system.** When total loads supported on wood framing exceed those specified in Tables 23-I-V-J-1, 23-I-V-J-3, 23-I-V-R-1, 23-I-V-R-2, 23-I-V-R-3, 23-I-V-R-4, 23-I-V-R-7, 23-I-V-R-8, 23-I-V-R-9 and 23-I-V-R-10, 23-V-R-1, 23-V-R-3, 23-V-R-7, 23-V-R-9, 23-VI-A, 23-VI-B, 23-VI-C and 23-VI-D, an engineering design shall be provided for the lateral-force-resisting system.

**2326.5.3 Veneer.** Anchored masonry and stone wall veneer shall not exceed 5 inches in thickness, shall conform to the requirements of Chapter 14 and shall not extend above the first story.

**2326.5.4 Unusually shaped buildings.** When of unusual shape, buildings of light-frame construction shall have a lateral-force-resisting system designed to resist the forces specified in Chapter 16. One or more of the following shall be considered to constitute an unusual shape:

**2326.5.4.1** When exterior braced wall panels, as required by Section 2326.11.3, are not in one plane vertically from the foundation to the uppermost story in which they are required.

**EXCEPTION:** Floors with cantilevers or setbacks not exceeding four times the nominal depth of the floor joists may support braced wall panels provided:

1. Floor joists are 2 inches by 10 inches (51 mm by 254 mm) or larger and spaced at not more than 16 inches (406 mm) on center.
2. The ratio of the back span to the cantilever is at least 2 to 1.
3. Floor joists at ends of braced wall panels are doubled.
4. A continuous rim joist is connected to ends of all cantilevered joists. The rim joist may be spliced using a metal tie not less than 0.058 inch (1.47 mm) (16 galvanized gage) and 1<sup>1</sup>/<sub>2</sub> inches (38 mm) wide fastened with six 16d nails.
5. Gravity loads carried at the end of cantilevered joists are limited to uniform wall and roof load and the reactions from headers having a span of 8 feet (2438 mm) or less.

**2326.5.4.2** When a section of floor or roof is not laterally supported by braced wall lines on all edges.

**EXCEPTION:** Portions of roofs or floors which do not support braced wall panels above may extend up to 6 feet (1829 mm) beyond a braced wall line.

**2326.5.4.3** When the end of a required braced wall panel extends more than 1 foot (305 mm) over an opening in the wall below. This provision is applicable to braced wall panels offset in plane and to braced wall panels offset out of plane as permitted by Section 2326.5.4.1, exception.

**EXCEPTION:** Braced wall panels may extend over an opening not more than 8 feet (2438 mm) in width when the header is a 4-inch by 12-inch (102 mm by 305 mm) or larger member.

**2326.5.4.4** When an opening in a floor or roof exceeds the lesser of 12 feet (3657 mm) or 50 percent of the least floor or roof dimension.

**2326.5.4.5** Construction where portions of a floor level are vertically offset such that the framing members on either side of the offset cannot be lapped or tied together in an approved manner as required by Section 2326.8.3.

**EXCEPTION:** Framing supported directly by foundations.

**2326.5.4.6** When braced wall lines do not occur in two perpendicular directions.

**2326.5.4.7** Other configurations which, in the opinion of the building official, create irregularities or discontinuities which are not addressed by Section 2326.

**2326.5.5 Lumber roof decks.** Lumber roof decks shall have solid sheathing.

**2326.5.6 Interior braced wall support.** In one-story buildings, interior braced wall lines shall be supported on continuous foundations at intervals not exceeding 50 feet (15 240 mm). In buildings more than one story in height, all interior braced wall panels shall be supported on continuous foundations.

**EXCEPTION:** Two-story buildings may have interior braced wall lines supported on continuous foundations at intervals not exceeding 50 feet (15 240 mm) provided:

1. Cripple wall height does not exceed 4 feet (1219 mm).
2. First-floor braced wall panels are supported on doubled floor joists, continuous blocking or floor beams.
3. Distance between bracing lines does not exceed twice the building width parallel to the braced wall line.

**2326.6 Foundation Plates or Sills.** Foundations and footings shall be as specified in Chapter 18. Foundation plates or sills resting on concrete or masonry foundations shall be bolted as required by Section 1806.6.

**2326.7 Girders.** Girders for single-story construction or girders supporting loads from a single floor shall not be less than 4 inches by 6 inches (102 mm by 153 mm) for spans 6 feet (1829 mm) or less, provided that girders are spaced not more than 8 feet (2438 mm) on center. Other girders shall be designed to support the loads specified in this code. Girder end joints shall occur over supports. When a girder is spliced over a support, an adequate tie shall be provided. The end of beams or girders supported on masonry or concrete shall not have less than 3 inches (76 mm) of bearing.

#### **2326.8 Floor Joists.**

**2326.8.1 General.** Spans for joists shall be in accordance with Tables 23-I-V-J-1 and 23-I-V-J-2.

**2326.8.2 Bearing.** Except where supported on a 1-inch by 4-inch (25 mm by 102 mm) ribbon strip and nailed to the adjoining stud, the ends of each joist shall not have less than 1½ inches (38 mm) of bearing on wood or metal, or less than 3 inches (76 mm) on masonry.

**2326.8.3 Framing details.** Joists shall be supported laterally at the ends and at each support by solid blocking except where the ends of joists are nailed to a header, band or rim joist or to an adjoining stud or by other approved means. Solid blocking shall not be less than 2 inches (51 mm) in thickness and the full depth of joist.

Notches on the ends of joists shall not exceed one fourth the joist depth. Holes bored in joists shall not be within 2 inches (51 mm) of the top or bottom of the joist, and the diameter of any such hole shall not exceed one third the depth of the joist. Notches in the top or bottom of joists shall not exceed one sixth the depth and shall not be located in the middle third of the span.

Joist framing from opposite sides of a beam, girder or partition shall be lapped at least 3 inches or the opposing joists shall be tied together in an approved manner.

Joists framing into the side of a wood girder shall be supported by framing anchors or on ledger strips not less than 2 inches by 2 inches (51 mm by 51 mm).

**2326.8.4 Framing around openings.** Trimmer and header joists shall be doubled, or of lumber of equivalent cross section, when the span of the header exceeds 4 feet (1219 mm). The ends of header joists more than 6 feet (1829 mm) long shall be supported by framing anchors or joist hangers unless bearing on a beam, partition or wall. Tail joists over 12 feet (3658 mm) long shall be supported at header by framing anchors or on ledger strips not less than 2 inches by 2 inches (51 mm by 51 mm).

**2326.8.5 Supporting bearing partitions.** Bearing partitions perpendicular to joists shall not be offset from supporting girders, walls or partitions more than the joist depth.

Joists under and parallel to bearing partitions shall be doubled.

**2326.8.6 Blocking.** Floor joists shall be blocked when required by the provisions of Sections 2306.7 and 2326.8.3.

#### **2326.9 Subflooring.**

**2326.9.1 Lumber subfloor.** Sheathing used as a structural subfloor shall conform to the limitations set forth in Tables 23-I-R-1 and 23-I-R-2.

Joints in subflooring shall occur over supports unless end-matched lumber is used, in which case each piece shall bear on at least two joists.

Subflooring may be omitted when joist spacing does not exceed 16 inches (406 mm) and 1-inch (25 mm) nominal tongue-and-groove wood strip flooring is applied perpendicular to the joists.

**2326.9.2 Wood structural panels.** Where used as structural subflooring, wood structural panels shall be as set forth in Tables 23-I-S-1 and 23-I-S-2. Wood structural panel combination subfloor underlayment shall have maximum spans as set forth in Table 23-I-T-1.

When wood structural panel floors are glued to joists with an adhesive in accordance with the adhesive manufacturer's directions, fasteners may be spaced a maximum of 12 inches (305 mm) on center at all supports.

**2326.9.3 Plank flooring.** Plank flooring shall be designed in accordance with the general provisions of this code.

In lieu of such design, 2-inch (51 mm) tongue-and-groove planking may be used in accordance with Table 23-I-U. Joints in such planking may be randomly spaced, provided the system is applied to not less than three continuous spans, planks are center-matched and end-matched or splined, each plank bears on at least one support and joints are separated by at least 24 inches (610 mm) in adjacent pieces. One-inch nominal strip square-edged flooring, 1/2-inch (13 mm) tongue-and-groove flooring, 3/8-inch (9.5 mm) wood structural panel or 3/8-inch (9.5 mm) Type 2-M particleboard shall be applied over random-length decking used as a floor. The strip and tongue-and-groove flooring shall be applied at right angles to the span of the planks. The 3/8-inch (9.5 mm) plywood shall be applied with the face grain at right angles to the span of the planks.

**2326.9.4 Particleboard.** Where used as structural subflooring or as combined subfloor underlayment, particleboard shall be as set forth in Table 23-I-T-2.

**2326.10 Particleboard Underlayment.** Particleboard floor underlayment shall conform to Type 1-M or to sanded Type 2-M-W grades of U.B.C. Standard 23-4. Underlayment shall not be less than 1/4 inch (6.4 mm) in thickness and shall be identified by the grade mark of an approved inspection agency. Underlayment shall be installed in accordance with this code and as recommended by the manufacturer.

### 2326.11 Wall Framing.

**2326.11.1 Size, height and spacing.** The size, height and spacing of studs shall be in accordance with Table 23-I-R-3 except that Utility grade studs shall not be spaced more than 16 inches (406 mm) on center, or support more than a roof and ceiling, or exceed 8 feet (2438 mm) in height for exterior walls and load-bearing walls or 10 feet (3048 mm) for interior nonload-bearing walls.

**2326.11.2 Framing details.** Studs shall be placed with their wide dimension perpendicular to the wall. Not less than three studs shall be installed at each corner of an exterior wall.

**EXCEPTION:** At corners, a third stud may be omitted through the use of wood spacers or backup cleats of 3/8-inch-thick (9.5 mm) wood structural panel, 3/8-inch (9.5 mm) Type 2-M particleboard, 1-inch-thick (25 mm) lumber or other approved devices which will serve as an adequate backing for the attachment of facing materials. Where fire-resistance ratings or shear values are involved, wood spacers, backup cleats or other devices shall not be used unless specifically approved for such use.

Bearing and exterior wall studs shall be capped with double top plates installed to provide overlapping at corners and at intersections with other partitions. End joints in double top plates shall be offset at least 48 inches (2438 mm).

**EXCEPTION:** A single top plate may be used, provided the plate is adequately tied at joints, corners and intersecting walls by at least the equivalent of 3-inch by 6-inch (76 mm by 152 mm) by 0.036-inch-thick (0.9 mm) galvanized steel that is nailed to each wall or segment of wall by six 8d nails or equivalent, provided the rafters, joists or trusses are centered over the studs with a tolerance of no more than 1 inch (25 mm).

When bearing studs are spaced at 24-inch (610 mm) intervals and top plates are less than two 2-inch by 6-inch (51 mm by 152 mm) or two 3-inch by 4-inch (76 mm by 102 mm) members and

when the floor joists, floor trusses or roof trusses which they support are spaced at more than 16-inch (406 mm) intervals, such joists or trusses shall bear within 5 inches (127 mm) of the studs beneath or a third plate shall be installed.

Interior nonbearing partitions may be capped with a single top plate installed to provide overlapping at corners and at intersections with other walls and partitions. The plate shall be continuously tied at joints by solid blocking at least 16 inches (406 mm) in length and equal in size to the plate or by  $\frac{1}{8}$ -inch by  $1\frac{1}{2}$ -inch (3.2 mm by 38 mm) metal ties with spliced sections fastened with two 16d nails on each side of the joint.

Studs shall have full bearing on a plate or sill not less than 2 inches (51 mm) in thickness having a width not less than that of the wall studs.

**2326.11.3 Bracing.** Braced wall lines shall consist of braced wall panels which meet the requirements for location, type and amount of bracing specified in Table 23-I-W and are in line or offset from each other by not more than 4 feet (1219 mm). Braced wall panels shall start at not more than 8 feet (2438 mm) from each end of a braced wall line. All braced wall panels shall be clearly indicated on the plans. Construction of braced wall panels shall be by one of the following methods:

1. Nominal 1-inch by 4-inch (25 mm by 102 mm) continuous diagonal braces let into top and bottom plates and intervening studs, placed at an angle not more than 60 degrees or less than 45 degrees from the horizontal, and attached to the framing in conformance with Table 23-I-Q.

2. Wood boards of  $\frac{5}{8}$ -inch (16 mm) net minimum thickness applied diagonally on studs spaced not over 24 inches (610 mm) on center.

3. Wood structural panel sheathing with a thickness not less than  $\frac{5}{16}$  inch (7.9 mm) for 16-inch (406 mm) stud spacing and not less than  $\frac{3}{8}$  inch (9.5 mm) for 24-inch (610 mm) stud spacing in accordance with Tables 23-I-M-1 and 23-I-N-1.

4. Fiberboard sheathing 4-foot by 8-foot (1219 mm by 2438 mm) panels not less than  $\frac{1}{2}$  inch (13 mm) thick applied vertically on studs spaced not over 16 inches (406 mm) on center when installed in accordance with Section 2315 and Table 23-I-P.

5. Gypsum board [sheathing  $\frac{1}{2}$  inch (13 mm) thick by 4 feet (1219 mm) wide, wallboard or veneer base] on studs spaced not over 24 inches (610 mm) on center and nailed at 7 inches (178 mm) on center with nails as required by Table 25-I.

6. Particleboard wall sheathing panels where installed in accordance with Table 23-I-N-2.

7. Portland cement plaster on studs spaced 16 inches (406 mm) on center installed in accordance with Table 25-I.

8. Hardboard panel siding when installed in accordance with Section 2320.6 and Table 23-I-O.

For methods 2, 3, 4, 6, 7 and 8, each braced wall panel must be at least 48 inches (1219 mm) in length, covering three stud spaces where studs are 16 inches (406 mm) apart and covering two stud spaces where studs are spaced 24 inches (610 mm) apart.

For method 5, each braced wall panel must be at least 96 inches (2438 mm) in length when applied to one face of a braced wall panel and 48 inches (1219 mm) when applied to both faces.

All vertical joints of panel sheathing shall occur over studs. Horizontal joints shall occur over blocking equal in size to the studding except where waived by the installation requirements for the specific sheathing materials.

Braced wall panel sole plates shall be nailed to the floor framing and top plates shall be connected to the framing above in accordance with Table 23-I-Q. Sills shall be bolted to the foundation or slab in accordance with Section 1806.6. Where joists are perpendicular to braced wall lines above, blocking shall be provided under and in line with the braced wall panels.

**2326.11.4 Alternate braced wall panels.** Any braced wall panel required by Section 2326.11.3 may be replaced by an alternate braced wall panel constructed in accordance with the following:

1. In one-story buildings, each panel shall have a length of not less than 2 feet 8 inches (813 mm) and a height of not more than 10 feet (3048 mm). Each panel shall be sheathed on one face with  $\frac{3}{8}$ -inch-minimum-thickness (9.5 mm) plywood sheathing nailed with 8d common or galvanized box nails in accordance with Table 23-I-Q and blocked at all plywood edges. Two anchor bolts installed in accordance with Section 1806.6, shall be provided in each panel. Anchor bolts shall be placed at panel quarter points. Each panel end stud shall have a tie-down device fastened to the foundation, capable of providing an approved uplift capacity of not less than 1,800 pounds (816.5 kg). The tie-down device shall be installed in accordance with the manufacturer's recommendations. The panels shall be supported directly on a foundation or on floor framing supported directly on a foundation which is continuous across the entire length of the braced wall line. This foundation shall be reinforced with not less than one No. 4 bar top and bottom.

2. In the first story of two-story buildings, each braced wall panel shall be in accordance with Section 2326.11.4, Item 1, except that the plywood sheathing shall be provided on both faces, three anchor bolts shall be placed at one-fifth points, and tie-down device uplift capacity shall not be less than 3,000 pounds (1360.8 kg).

**2326.11.5 Cripple walls.** Foundation cripple walls shall be framed of studs not less in size than the studding above with a minimum length of 14 inches (356 mm), or shall be framed of solid blocking. When exceeding 4 feet (1219 mm) in height, such walls shall be framed of studs having the size required for an additional story.

Such walls having a stud height exceeding 14 inches (356 mm) shall be considered to be first-story walls for the purpose of determining the bracing required by Section 2326.11.3. Solid blocking or wood structural panel sheathing may be used to brace cripple walls having a stud height of 14 inches (356 mm) or less.

Spacing of boundary nailing for required wall bracing shall not exceed 6 inches (152 mm) on center along the foundation plate and the top plate of the cripple wall. Nail size, nail spacing for field nailing and more restrictive boundary nailing requirements shall be as required elsewhere in the code for the specific bracing material used.

**2326.11.6 Headers.** Headers and lintels shall conform to the requirements set forth in this paragraph and together with their supporting systems shall be designed to support the loads specified in this code. All openings 4 feet (1219 mm) wide or less in bearing walls shall be provided with headers consisting of either two pieces of 2-inch (51 mm) framing lumber placed on edge and securely fastened together or 4-inch (102 mm) lumber of equivalent cross section. All openings more than 4 feet (1219 mm) wide shall be provided with headers or lintels. Each end of a lintel or header shall have a length of bearing of not less than  $1\frac{1}{2}$  inches (38 mm) for the full width of the lintel.

**2326.11.7 Pipes in walls.** Stud partitions containing plumbing, heating, or other pipes shall be so framed and the joists underneath so spaced as to give proper clearance for the piping. Where a partition containing such piping runs parallel to the floor joists, the joists underneath such partitions shall be doubled and spaced to permit the passage of such pipes and shall be bridged. Where plumbing, heating or other pipes are placed in or partly in a partition, necessitating the cutting of the soles or plates, a metal tie not less than 0.058 inches (1.47 mm) (16 galvanized gage) and  $1\frac{1}{2}$  inches (38 mm) wide shall be fastened to each plate across and to each side of the opening with not less than six 16d nails.

**2326.11.8 Bridging.** Unless covered by interior or exterior wall coverings or sheathing meeting the minimum requirements of this code, all stud partitions or walls with studs having a height-to-least-thickness ratio exceeding 50 shall have bridging not less than 2 inches (51 mm) in thickness and of the same width as the studs fitted snugly and nailed thereto to provide adequate lateral support.

**2326.11.9 Cutting and notching.** In exterior walls and bearing partitions, any wood stud may be cut or notched to a depth not exceeding 25 percent of its width. Cutting or notching of studs to a

depth not greater than 40 percent of the width of the stud is permitted in nonbearing partitions supporting no loads other than the weight of the partition.

**2326.11.10 Bored holes.** A hole not greater in diameter than 40 percent of the stud width may be bored in any wood stud. Bored holes not greater than 60 percent of the width of the stud are permitted in nonbearing partitions or in any wall where each bored stud is doubled, provided not more than two such successive doubled studs are so bored.

In no case shall the edge of the bored hole be nearer than  $\frac{5}{8}$  inch (16 mm) to the edge of the stud. Bored holes shall not be located at the same section of stud as a cut or notch.

#### **2326.12 Roof and Ceiling Framing.**

**2326.12.1 General.** The framing details required in this section apply to roofs having a minimum slope of 3 units vertical in 12 units horizontal (25% slope) or greater. When the roof slope is less than 3 units vertical in 12 units horizontal (25% slope), members supporting rafters and ceiling joists such as ridge board, hips and valleys shall be designed as beams.

**2326.12.2 Spans.** Allowable spans for ceiling joists shall be in accordance with Tables 23-I-V-J-3 and 23-I-V-J-4. Allowable spans for rafters shall be in accordance with Tables 23-I-V-R-1 through 23-I-V-R-12, where applicable.

**2326.12.3 Framing.** Rafters shall be framed directly opposite each other at the ridge. There shall be a ridge board at least 1-inch (25 mm) nominal thickness at all ridges and not less in depth than the cut end of the rafter. At all valleys and hips there shall be a single valley or hip rafter not less than 2-inch (51 mm) nominal thickness and not less in depth than the cut end of the rafter.

**2326.12.4 Notches and holes.** Notching at the ends of rafters or ceiling joists shall not exceed one fourth the depth. Notches in the top or bottom of the rafter or ceiling joist shall not exceed one sixth the depth and shall not be located in the middle one third of the span, except that a notch not exceeding one third of the depth is permitted in the top of the rafter or ceiling joist not further from the face of the support than the depth of the member.

Holes bored in rafters or ceiling joists shall not be within 2 inches (51 mm) of the top and bottom and their diameter shall not exceed one third the depth of the member.

**2326.12.5 Framing around openings.** Trimmer and header rafters shall be doubled, or of lumber of equivalent cross-section, when the span of the header exceeds 4 feet (1219 mm). The ends of header rafters more than 6 feet (1829 mm) long shall be supported by framing anchors or rafter hangers unless bearing on a beam, partition or wall.

**2326.12.6 Rafter ties.** Rafters shall be nailed to adjacent ceiling joists to form a continuous tie between exterior walls when such joists are parallel to the rafters. Where not parallel, rafters shall be tied to 1-inch by 4-inch (25 mm by 102 mm) (nominal) minimum-size crossties. Rafter ties shall be spaced not more than 4 feet (1219 mm) on center.

**2326.12.7 Purlins.** Purlins to support roof loads may be installed to reduce the span of rafters within allowable limits and shall be supported by struts to bearing walls. The maximum span of 2-inch by 4-inch (51 mm by 102 mm) purlins shall be 4 feet (1219 mm). The maximum span of the 2-inch by 6-inch (51 mm by 152 mm) purlin shall be 6 feet (1829 mm) but in no case shall the purlin be smaller than the supported rafter. Struts shall not be smaller than 2-inch by 4-inch (51 mm by 102 mm) members. The unbraced length of struts shall not exceed 8 feet (2438 mm) and the minimum slope of the struts shall not be less than 45 degrees from the horizontal.

**2326.12.8 Blocking.** Roof rafters and ceiling joists shall be supported laterally to prevent rotation and lateral displacement when required by Section 2306.7. Roof trusses shall be supported laterally at points of bearing by solid blocking to prevent rotation and lateral displacement.

**2326.12.9 Roof sheathing.** Roof sheathing shall be in accordance with Tables 23-I-S-1 and 23-I-S-2 for wood structural panels, Tables 23-I-R-1 and 23-I-R-2 for lumber or Table 23-I-S-3 for particleboard.

Joints in lumber sheathing shall occur over supports unless approved end-matched lumber is used, in which case each piece shall bear on at least two supports.

Wood structural panels used for roof sheathing shall be bonded by intermediate or exterior glue. Wood structural panel roof sheathing exposed on the underside shall be bonded with exterior glue.

**2326.12.10 Roof planking.** Planking shall be designed in accordance with the general provisions of this code.

In lieu of such design, 2-inch (51 mm) tongue-and-groove planking may be used in accordance with Table 23-I-U. Joints in such planking may be randomly spaced, provided the system is applied to not less than three continuous spans, planks are center-matched and end-matched or splined, each plank bears on at least one support, and joints are separated by at least 24 inches (610 mm) in adjacent pieces.

**2326.13 Exit Facilities.** In Seismic Zones 3 and 4, exterior exit balconies, stairs and similar exit facilities shall be positively anchored to the primary structure at not over 8 feet (2438 mm) on center or shall be designed for lateral forces. Such attachment shall not be accomplished by use of toenails or nails subject to withdrawal.

**TABLE 23-I-A-1—BASE DESIGN VALUES FOR VISUALLY GRADED DIMENSION LUMBER**  
 (All species except Southern Pine—see Table 23-I-A-2)  
 (Tabulated design values are for normal load duration and dry service conditions.)

SPECIES AND COMMERCIAL GRADE	SIZE CLASSIFICATION  × 25.4 for mm	DESIGN VALUES IN POUNDS PER SQUARE INCH (psi)						GRADING RULES AGENCY
		× 0.00689 for N/mm <sup>2</sup>						
		Bending $F_b$	Tension Parallel to Grain $F_t$	Shear Parallel to Grain $F_v$	Compression Perpendicular to Grain $F_{c\perp}$	Compression Parallel to Grain $F_c$	Modulus of Elasticity $E$	
<b>ASPEN</b>								
Select structural		875	500	60	265	725	1,100,000	NELMA NSLB WWPA
No. 1	2" to 4" thick	625	375	60	265	600	1,100,000	
No. 2		600	350	60	265	450	1,000,000	
No. 3	2" and wider	350	200	60	265	275	900,000	
Stud		475	275	60	265	300	900,000	
Construction	2" to 4" thick	700	400	60	265	625	900,000	
Standard		375	225	60	265	475	900,000	
Utility	2" to 4" wide	175	100	60	265	300	800,000	
<b>BEECH-BIRCH-HICKORY</b>								
Select structural		1,450	850	100	715	1,200	1,700,000	NELMA
No. 1	2" to 4" thick	1,050	600	100	715	950	1,600,000	
No. 2		1,000	600	100	715	750	1,500,000	
No. 3	2" and wider	575	350	100	715	425	1,300,000	
Stud		775	450	100	715	475	1,300,000	
Construction	2" to 4" thick	1,150	675	100	715	1,000	1,400,000	
Standard		650	375	100	715	775	1,300,000	
Utility	2" to 4" wide	300	175	100	715	500	1,200,000	
<b>COTTONWOOD</b>								
Select structural		875	525	65	320	775	1,200,000	NSLB
No. 1	2" to 4" thick	625	375	65	320	625	1,200,000	
No. 2		625	350	65	320	475	1,100,000	
No. 3	2" and wider	350	200	65	320	275	1,000,000	
Stud		475	275	65	320	300	1,000,000	
Construction	2" to 4" thick	700	400	65	320	650	1,000,000	
Standard		400	225	65	320	500	900,000	
Utility	2" to 4" wide	175	100	65	320	325	900,000	

<b>DOUGLAS FIR-LARCH</b>								
Select structural		1,450	1,000	95	625	1,700	1,900,000	WCLIB WWPA
No. 1 and better	2" to 4" thick	1,150	775	95	625	1,500	1,800,000	
No. 1		1,000	675	95	625	1,450	1,700,000	
No. 2	2" and wider	875	575	95	625	1,300	1,600,000	
No. 3		500	325	95	625	750	1,400,000	
Stud		675	450	95	625	825	1,400,000	
Construction	2" to 4" thick	1,000	650	95	625	1,600	1,500,000	
Standard		550	375	95	625	1,350	1,400,000	
Utility	2" to 4" wide	275	175	95	625	875	1,300,000	
<b>DOUGLAS FIR-LARCH (North)</b>								
Select structural	2" to 4" thick	1,300	800	95	625	1,900	1,900,000	NLGA
No. 1/No. 2		825	500	95	625	1,350	1,600,000	
No. 3	2" and wider	475	300	95	625	775	1,400,000	
Stud		650	375	95	625	850	1,400,000	
Construction	2" to 4" thick	950	575	95	625	1,750	1,500,000	
Standard		525	325	95	625	1,400	1,400,000	
Utility	2" to 4" wide	250	150	95	625	925	1,300,000	
<b>DOUGLAS FIR-SOUTH</b>								
Select structural		1,300	875	90	520	1,550	1,400,000	WWPA
No. 1	2" to 4" thick	900	600	90	520	1,400	1,300,000	
No. 2		825	525	90	520	1,300	1,200,000	
No. 3	2" and wider	475	300	90	520	750	1,100,000	
Stud		650	425	90	520	825	1,100,000	
Construction	2" to 4" thick	925	600	90	520	1,550	1,200,000	
Standard		525	350	90	520	1,300	1,100,000	
Utility	2" to 4" wide	250	150	90	520	875	1,000,000	
<b>EASTERN HEMLOCK-TAMARACK</b>								
Select structural		1,250	575	85	555	1,200	1,200,000	NELMA NSLB
No. 1	2" to 4" thick	775	350	85	555	1,000	1,100,000	
No. 2		575	275	85	555	825	1,100,000	
No. 3	2" and wider	350	150	85	555	475	900,000	
Stud		450	200	85	555	525	900,000	
Construction	2" to 4" thick	675	300	85	555	1,050	1,000,000	
Standard		375	175	85	555	850	900,000	
Utility	2" to 4" wide	175	75	85	555	550	800,000	

(Continued)

TABLE 23-I-A-1—BASE DESIGN VALUES FOR VISUALLY GRADED DIMENSION LUMBER—(Continued)

SPECIES AND COMMERCIAL GRADE	SIZE CLASSIFICATION	DESIGN VALUES IN POUNDS PER SQUARE INCH (psi)						GRADING RULES AGENCY
		× 0.00689 for N/mm <sup>2</sup>						
	× 25.4 for mm	Bending $F_b$	Tension Parallel to Grain $F_t$	Shear Parallel to Grain $F_v$	Compression Perpendicular to Grain $F_{c\perp}$	Compression Parallel to Grain $F_c$	Modulus of Elasticity $E$	
<b>EASTERN SOFTWOODS</b>								
Select structural		1,250	575	70	335	1,200	1,200,000	NELMA NSLB
No. 1	2" to 4" thick	775	350	70	335	1,000	1,100,000	
No. 2		575	275	70	335	825	1,100,000	
No. 3	2" and wider	350	150	70	335	475	900,000	
Stud		450	200	70	335	525	900,000	
Construction	2" to 4" thick	675	300	70	335	1,050	1,000,000	
Standard		375	175	70	335	850	900,000	
Utility	2" to 4" wide	175	75	70	335	550	800,000	
<b>EASTERN WHITE PINE</b>								
Select structural		1,250	575	70	350	1,200	1,200,000	NELMA NSLB
No. 1	2" to 4" thick	775	350	70	350	1,000	1,100,000	
No. 2		575	275	70	350	825	1,100,000	
No. 3	2" and wider	350	150	70	350	475	900,000	
Stud		450	200	70	350	525	900,000	
Construction	2" to 4" thick	675	300	70	350	1,050	1,000,000	
Standard		375	175	70	350	850	900,000	
Utility	2" to 4" wide	175	75	70	350	550	800,000	
<b>HEM-FIR</b>								
Select structural		1,400	900	75	405	1,500	1,600,000	WCLIB WWPA
No. 1 and better	2" to 4" thick	1,050	700	75	405	1,350	1,500,000	
No. 1		950	600	75	405	1,300	1,500,000	
No. 2	2" and wider	850	500	75	405	1,250	1,300,000	
No. 3		500	300	75	405	725	1,200,000	
Stud		675	400	75	405	800	1,200,000	
Construction	2" to 4" thick	975	575	75	405	1,500	1,300,000	
Standard		550	325	75	405	1,300	1,200,000	
Utility	2" to 4" wide	250	150	75	405	850	1,100,000	

<b>HEM-FIR (North)</b>								
Select structural	2" to 4" thick	1,300	775	75	370	1,650	1,700,000	NLGA
No. 1/No. 2		1,000	550	75	370	1,450	1,600,000	
No. 3	2" and wider	575	325	75	370	850	1,400,000	
Stud		775	425	75	370	925	1,400,000	
Construction	2" to 4" thick	1,150	625	75	370	1,750	1,500,000	
Standard		625	350	75	370	1,500	1,400,000	
Utility	2" to 4" wide	300	175	75	370	975	1,300,000	
<b>MIXED MAPLE</b>								
Select structural		1,000	600	100	620	875	1,300,000	NELMA
No. 1	2" to 4" thick	725	425	100	620	700	1,200,000	
No. 2		700	425	100	620	550	1,100,000	
No. 3	2" and wider	400	250	100	620	325	1,000,000	
Stud		550	325	100	620	350	1,000,000	
Construction	2" to 4" thick	800	475	100	620	725	1,100,000	
Standard		450	275	100	620	575	1,000,000	
Utility	2" to 4" wide	225	125	100	620	375	900,000	
<b>MIXED OAK</b>								
Select structural		1,150	675	85	800	1,000	1,100,000	NELMA
No. 1	2" to 4" thick	825	500	85	800	825	1,000,000	
No. 2		800	475	85	800	625	900,000	
No. 3	2" and wider	475	275	85	800	375	800,000	
Stud		625	375	85	800	400	800,000	
Construction	2" to 4" thick	925	550	85	800	850	900,000	
Standard		525	300	85	800	650	800,000	
Utility	2" to 4" wide	250	150	85	800	425	800,000	
<b>NORTHERN RED OAK</b>								
Select structural		1,400	800	110	885	1,150	1,400,000	NELMA
No. 1	2" to 4" thick	1,000	575	110	885	925	1,400,000	
No. 2		975	575	110	885	725	1,300,000	
No. 3	2" and wider	550	325	110	885	425	1,200,000	
Stud		750	450	110	885	450	1,200,000	
Construction	2" to 4" thick	1,100	650	110	885	975	1,200,000	
Standard		625	350	110	885	850	1,100,000	
Utility	2" to 4" wide	300	175	110	885	500	1,000,000	

(Continued)

TABLE 23-1-A-1—BASE DESIGN VALUES FOR VISUALLY GRADED DIMENSION LUMBER—(Continued)

SPECIES AND COMMERCIAL GRADE	SIZE CLASSIFICATION	DESIGN VALUES IN POUNDS PER SQUARE INCH (psi)						GRADING RULES AGENCY
		× 0.00689 for N/mm <sup>2</sup>						
	× 25.4 for mm	Bending $F_b$	Tension Parallel to Grain $F_t$	Shear Parallel to Grain $F_v$	Compression Perpendicular to Grain $F_{c\perp}$	Compression Parallel to Grain $F_c$	Modulus of Elasticity $E$	
<b>NORTHERN SPECIES</b>								
Select structural	2" to 4" thick	950	450	65	350	1,100	1,100,000	NLGA
No. 1/No. 2		575	275	65	350	825	1,100,000	
No. 3	2" and wider	350	150	65	350	475	1,000,000	
Stud		450	200	65	350	525	1,000,000	
Construction	2" to 4" thick	675	300	65	350	1,050	1,000,000	
Standard		375	175	65	350	850	900,000	
Utility	2" to 4" wide	175	75	65	350	550	900,000	
<b>NORTHERN WHITE CEDAR</b>								
Select structural		775	450	60	370	750	800,000	NELMA
No. 1	2" to 4" thick	575	325	60	370	600	700,000	
No. 2		550	325	60	370	475	700,000	
No. 3	2" and wider	325	175	60	370	275	600,000	
Stud		425	250	60	370	300	600,000	
Construction	2" to 4" thick	625	375	60	370	625	700,000	
Standard		350	200	60	370	475	600,000	
Utility	2" to 4" wide	175	100	60	370	325	600,000	
<b>RED MAPLE</b>								
Select structural		1,300	750	105	615	1,100	1,700,000	NELMA
No. 1	2" to 4" thick	925	550	105	615	900	1,600,000	
No. 2		900	525	105	615	700	1,500,000	
No. 3	2" and wider	525	300	105	615	400	1,300,000	
Stud		700	425	105	615	450	1,300,000	
Construction	2" to 4" thick	1,050	600	105	615	925	1,400,000	
Standard		575	325	105	615	725	1,300,000	
Utility	2" to 4" wide	275	150	105	615	475	1,200,000	
<b>RED OAK</b>								
Select structural		1,150	675	85	820	1,000	1,400,000	NELMA
No. 1	2" to 4" thick	825	500	85	820	825	1,300,000	
No. 2		800	475	85	820	625	1,200,000	
No. 3	2" and wider	475	275	85	820	375	1,100,000	
Stud		625	375	85	820	400	1,100,000	
Construction	2" to 4" thick	925	550	85	820	850	1,200,000	
Standard		525	300	85	820	650	1,100,000	
Utility	2" to 4" wide	250	150	85	820	425	1,000,000	

<b>REDWOOD</b>								
Clear structural		1,750	1,000	145	650	1,850	1,400,000	RIS
Select structural		1,350	800	80	650	1,500	1,400,000	
Select structural, open grain		1,100	625	80	425	1,100	1,100,000	
No. 1	2" to 4" thick	975	575	80	650	1,200	1,300,000	
No. 1, open grain		775	450	80	425	900	1,100,000	
No. 2	2" and wider	925	525	80	650	950	1,200,000	
No. 2, open grain		725	425	80	425	700	1,000,000	
No. 3		525	300	80	650	550	1,100,000	
No. 3, open grain		425	250	80	425	400	900,000	
Stud		575	325	80	425	450	900,000	
Construction	2" to 4" thick	825	475	80	425	925	900,000	
Standard		450	275	80	425	725	900,000	
Utility	2" to 4" wide	225	125	80	425	475	800,000	
<b>SPRUCE-PINE-FIR</b>								
Select structural	2" to 4" thick	1,250	675	70	425	1,400	1,500,000	NLGA
No. 1/No. 2		875	425	70	425	1,100	1,400,000	
No. 3	2" and wider	500	250	70	425	625	1,200,000	
Stud		675	325	70	425	675	1,200,000	
Construction	2" to 4" thick	975	475	70	425	1,350	1,300,000	
Standard		550	275	70	425	1,100	1,200,000	
Utility	2" to 4" wide	250	125	70	425	725	1,100,000	
<b>SPRUCE-PINE-FIR (South)</b>								
Select structural		1,300	575	70	335	1,200	1,300,000	NELMA NSLB WCLIB WWPA
No. 1	2" to 4" thick	850	400	70	335	1,050	1,200,000	
No. 2		750	325	70	335	975	1,100,000	
No. 3	2" and wider	425	200	70	335	550	1,000,000	
Stud		575	250	70	335	600	1,000,000	
Construction	2" to 4" thick	850	375	70	335	1,200	1,000,000	
Standard		475	225	70	335	1,000	900,000	
Utility	2" to 4" wide	225	100	70	335	650	900,000	
<b>WESTERN CEDARS</b>								
Select structural		1,000	600	75	425	1,000	1,100,000	WCLIB WWPA
No. 1	2" to 4" thick	725	425	75	425	825	1,000,000	
No. 2		700	425	75	425	650	1,000,000	
No. 3	2" and wider	400	250	75	425	375	900,000	
Stud		550	325	75	425	400	900,000	
Construction	2" to 4" thick	800	475	75	425	850	900,000	
Standard		450	275	75	425	650	800,000	
Utility	2" to 4" wide	225	125	75	425	428	800,000	

(Continued)

TABLE 23-I-A-1—BASE DESIGN VALUES FOR VISUALLY GRADED DIMENSION LUMBER—(Continued)

SPECIES AND COMMERCIAL GRADE	SIZE CLASSIFICATION	DESIGN VALUES IN POUNDS PER SQUARE INCH (psi)						GRADING RULES AGENCY
		× 0.00689 for N/mm <sup>2</sup>						
	× 25.4 for mm	Bending $F_b$	Tension Parallel to Grain $F_t$	Shear Parallel to Grain $F_v$	Compression Perpendicular to Grain $F_{c\perp}$	Compression Parallel to Grain $F_c$	Modulus of Elasticity $E$	
<b>WESTERN WOODS</b>								
Select structural		875	400	70	335	1,050	1,200,000	WCLIB WWPA
No. 1	2" to 4" thick	650	300	70	335	925	1,100,000	
No. 2		650	275	70	335	875	1,000,000	
No. 3	2" and wider	375	175	70	335	500	900,000	
Stud		500	225	70	335	550	900,000	
Construction	2" to 4" thick	725	325	70	335	1,050	1,000,000	
Standard		400	175	70	335	900	900,000	
Utility	2" to 4" wide	200	75	70	335	600	800,000	
<b>WHITE OAK</b>								
Select structural		1,200	700	110	800	1,100	1,100,000	NELMA
No. 1	2" to 4" thick	875	500	110	800	900	1,000,000	
No. 2		850	500	110	800	700	900,000	
No. 3	2" and wider	475	275	110	800	400	800,000	
Stud		650	375	110	800	450	800,000	
Construction	2" to 4" thick	950	550	110	800	925	900,000	
Standard		525	325	110	800	725	800,000	
Utility	2" to 4" wide	250	150	110	800	475	800,000	
<b>YELLOW POPLAR</b>								
Select structural		1,000	575	75	420	900	1,500,000	NSLB
No. 1	2" to 4" thick	725	425	75	420	725	1,400,000	
No. 2		700	400	75	420	575	1,300,000	
No. 3	2" and wider	400	225	75	420	325	1,200,000	
Stud		550	325	75	420	350	1,200,000	
Construction	2" to 4" thick	800	475	75	420	750	1,300,000	
Standard		450	250	75	420	575	1,100,000	
Utility	2" to 4" wide	200	125	75	420	375	1,100,000	

**Notes:**

- Lumber Dimensions.** Tabulated design values are applicable to lumber that will be used under dry conditions such as in most covered structures. For 2-inch- (51 mm) to 4-inch-thick (102 mm) lumber, the DRY dressed sizes shall be used regardless of the moisture content at the time of manufacture or use. In calculating design values, the natural gain in strength and stiffness that occurs as lumber dries has been taken into consideration as well as the reduction in size that occurs when unseasoned lumber shrinks. The gain in load-carrying capacity due to increased strength and stiffness resulting from drying more than offsets the design effect of size reductions due to shrinkage.
- Stress-rated Boards.** Stress-rated boards of nominal 1-inch (25 mm), 1<sup>1</sup>/<sub>4</sub>-inch (32 mm) and 1<sup>1</sup>/<sub>2</sub>-inch (38 mm) thickness, 2 inches (51 mm) and wider, of most species, are permitted the design values shown for select structural, No. 1 and better, No. 1, No. 2, No. 3, stud, construction, standard, utility, clear heart structural and clear structural grades as shown in the 2-inch- (51 mm) to 4-inch-thick (102 mm) categories herein, when graded in accordance with the stress-rated board provisions in the applicable

grading rules. Information on stress-rated board grades applicable to the various species is available from the respective grading rules agencies. Information on additional design values may also be available from the respective grading agencies.

3. **Size Factor,  $C_F$ .** Tabulated bending, tension and compression-parallel-to-grain design values for dimension lumber 2 inches to 4 inches (51 mm to 102 mm) thick shall be multiplied by the following size factors:

**SIZE FACTORS,  $C_F$**

GRADES	WIDTH (Inches)  × 25.4 for mm	$F_b$		$F_t$	$F_c$
		Thickness			
		2" and 3" (51 mm and 76 mm)	4" (102 mm)		
Select structural, No. 1 and better No. 1, No. 2, No. 3	2, 3 and 4	1.5	1.5	1.5	1.15
	5	1.4	1.4	1.4	1.1
	6	1.3	1.3	1.3	1.1
	8	1.2	1.3	1.2	1.05
	10	1.1	1.2	1.1	1.0
	12	1.0	1.1	1.0	1.0
	14 and wider	0.9	1.0	0.9	0.9
Stud	2, 3 and 4	1.1	1.1	1.1	1.05
	5 and 6	1.0	1.0	1.0	1.0
Construction and Standard	2, 3 and 4	1.0	1.0	1.0	1.0
Utility	4	1.0	1.0	1.0	1.0
	2 and 3	0.4	—	0.4	0.6

4. **Repetitive Member Factor,  $C_r$ .** Bending design values,  $F_b$ , for dimension lumber 2 inches (51 mm) to 4 inches (102 mm) thick shall be multiplied by the repetitive member factor,  $C_r = 1.15$ , when such members are used as joists, truss chords, rafters, studs, planks, decking or similar members which are in contact or spaced not more than 24 inches (610 mm) on center, are not less than three in number and are joined by floor, roof or other load-distributing elements adequate to support the design load.
5. **Flat-use Factor,  $C_{fu}$ .** Bending design values adjusted by size factors are based on edgewise use (load applied to narrow face). When dimension lumber is used flatwise (load applied to wide face), the bending design value,  $F_b$ , shall also be multiplied by the following flat-use factors:

**FLAT-USE FACTORS,  $C_{fu}$**

WIDTH (Inches)  × 25.4 for mm	THICKNESS	
	2" and 3" (51 mm and 76 mm)	4" (102 mm)
2 and 3	1.0	—
4	1.1	1.0
5	1.1	1.05
6	1.15	1.05
8	1.15	1.05
10 and wider	1.2	1.1

(Continued)

## NOTES TO TABLE 23-I-A-1—(Continued)

6. **Wet Service Factor,  $C_M$ .** When dimension lumber is used where moisture content will exceed 19 percent for an extended time period, design values shall be multiplied by the appropriate wet service factors from the following table:

WET SERVICE FACTORS,  $C_M$ 

$F_b$	$F_t$	$F_v$	$F_c \perp$	$F_c$	$E$
0.85*	1.0	0.97	0.67	0.8**	0.9

\*when  $(F_b)(C_F) \leq 1,150$  psi (7.92 N/mm<sup>2</sup>),  $C_M = 1.0$

\*\*when  $(F_c)(C_F) \leq 750$  psi (5.17 N/mm<sup>2</sup>),  $C_M = 1.0$

7. **Shear Stress Factor,  $C_H$ .** Tabulated shear design values parallel to grain have been reduced to allow for the occurrence of splits, checks and shakes. Tabulated shear design values parallel to grain,  $F_v$ , shall be permitted to be multiplied by the shear stress factors specified in the following table when length of split, or size of check or shake is known and no increase in them is anticipated. When shear stress factors are used for redwood, a tabulated design value of  $F_v = 80$  psi (0.55 N/mm<sup>2</sup>) shall be assigned for all grades of redwood dimension lumber. Shear stress factors shall be permitted to be linearly interpolated.

SHEAR STRESS FACTORS,  $C_H$ 

Length of split on wide face of 2-inch (51 mm) (nominal) lumber	$C_H$	Length of split on wide face of 3-inch (76 mm) (nominal) and thicker lumber	$C_H$	Size of shake* in 2-inch (51 mm) (nominal) and thicker lumber	$C_H$
no split	2.00	no split	2.00	no shake	2.00
1/2 by wide face	1.67	1/2 by narrow face	1.67	1/6 by narrow face	1.67
3/4 by wide face	1.50	3/4 by narrow face	1.50	1/4 by narrow face	1.50
1 by wide face	1.33	1 by narrow face	1.33	1/3 by narrow face	1.33
1 1/2 by wide face or more	1.00	1 1/2 by narrow face or more	1.00	1/2 by narrow face or more	1.00
				*Shake is measured at the end between lines enclosing the shake and perpendicular to the loaded face.	

**TABLE 23-I-A-2—DESIGN VALUES FOR VISUALLY GRADED SOUTHERN PINE DIMENSION LUMBER**  
 (Tabulated design values are for normal load duration and dry service conditions, unless specified otherwise.)

SPECIES AND COMMERICAL GRADE	SIZE CLASSIFICATION  × 25.4 for mm	DESIGN VALUES IN POUNDS PER SQUARE INCH (psi)						GRADING RULES AGENCY
		× 0.00689 for N/mm <sup>2</sup>						
		Bending $F_b$	Tension Parallel to Grain $F_t$	Shear Parallel to Grain $F_v$	Compression Perpendicular to Grain $F_{c\perp}$	Compression Parallel to Grain $F_c$	Modulus of Elasticity $E$	
<b>MIXED SOUTHERN PINE</b>								
Select structural		2,050	1,200	100	565	1,800	1,600,000	SPIB
No. 1	2" to 4" thick	1,450	875	100	565	1,650	1,500,000	
No. 2		1,300	775	90	565	1,650	1,400,000	
No. 3	2" to 4" wide	750	450	90	565	950	1,200,000	
Stud		775	450	90	565	950	1,200,000	
Construction	2" to 4" thick	1,000	600	100	565	1,700	1,300,000	
Standard		550	325	90	565	1,450	1,200,000	
Utility	4" wide	275	150	90	565	950	1,100,000	
Select structural		1,850	1,100	90	565	1,700	1,600,000	
No. 1	2" to 4" thick	1,300	750	90	565	1,550	1,500,000	
No. 2		1,150	675	90	565	1,550	1,400,000	
No. 3	5" to 6" thick	675	400	90	565	875	1,200,000	
Stud		675	400	90	565	875	1,200,000	
Select structural		1,750	1,000	90	565	1,600	1,600,000	
No. 1	2" to 4" thick	1,200	700	90	565	1,450	1,500,000	
No. 2	8" wide	1,050	625	90	565	1,450	1,400,000	
No. 3		625	375	90	565	850	1,200,000	
Select structural		1,500	875	90	565	1,600	1,600,000	
No. 1	2" to 4" thick	1,050	600	90	565	1,450	1,500,000	
No. 2	10" wide	925	550	90	565	1,450	1,400,000	
No. 3		525	325	90	565	825	1,200,000	
Select structural		1,400	825	90	565	1,550	1,600,000	
No. 1	2" to 4" thick	975	575	90	565	1,400	1,500,000	
No. 2	12" wide	875	525	90	565	1,400	1,400,000	
No. 3		500	300	90	565	800	1,200,000	

(Continued)

TABLE 23-I-A-2—DESIGN VALUES FOR VISUALLY GRADED SOUTHERN PINE DIMENSION LUMBER—(Continued)

SPECIES AND COMMERICAL GRADE	SIZE CLASSIFICATION  × 25.4 for mm	DESIGN VALUES IN POUNDS PER SQUARE INCH (psi) × 0.00689 for N/mm <sup>2</sup>						GRADING RULES AGENCY
		Bending $F_b$	Tension Parallel to Grain $F_t$	Shear Parallel to Grain $F_v$	Compression Perpendicular to Grain $F_{c\perp}$	Compression Parallel to Grain $F_c$	Modulus of Elasticity $E$	
		<b>SOUTHERN PINE</b>						
Dense select structural		3,050	1,650	100	660	2,250	1,900,000	SPIB
Select structural		2,850	1,600	100	565	2,100	1,800,000	
Non-dense select structural		2,650	1,350	100	480	1,950	1,700,000	
No. 1 dense	2" to 4" thick	2,000	1,100	100	660	2,000	1,800,000	
No. 1		1,850	1,050	100	565	1,850	1,700,000	
No. 1 non-dense	2" to 4" wide	1,700	900	100	480	1,700	1,600,000	
No. 2 dense		1,700	875	90	660	1,850	1,700,000	
No. 2		1,500	825	90	565	1,650	1,600,000	
No. 2 non-dense		1,350	775	90	480	1,600	1,400,000	
No. 3		850	475	90	565	975	1,400,000	
Stud		875	500	90	565	975	1,400,000	
Construction	2" to 4" thick	1,100	625	100	565	1,800	1,500,000	
Standard		625	350	90	565	1,500	1,300,000	
Utility	4" wide	300	175	90	565	975	1,300,000	
Dense select structural		2,700	1,500	90	660	2,150	1,900,000	
Select structural		2,550	1,400	90	565	2,000	1,800,000	
Non-dense select structural		2,350	1,200	90	480	1,850	1,700,000	
No. 1 dense	2" to 4" thick	1,750	950	90	660	1,900	1,800,000	
No. 1		1,650	900	90	565	1,750	1,700,000	
No. 1 non-dense	5" to 6" wide	1,500	800	90	480	1,600	1,600,000	
No. 2 dense		1,450	775	90	660	1,750	1,700,000	
No. 2		1,250	725	90	565	1,600	1,600,000	
No. 2 non-dense		1,150	675	90	480	1,500	1,400,000	
No. 3		750	425	90	565	925	1,400,000	
Stud		775	425	90	565	925	1,400,000	

Dense select structural	2" to 4" thick 8" wide	2,450	1,350	90	660	2,050	1,900,000	SPIB
Select structural		2,300	1,300	90	565	1,900	1,800,000	
Non-dense select structural		2,100	1,100	90	480	1,750	1,700,000	
No. 1 dense		1,650	875	90	660	1,800	1,800,000	
No. 1		1,500	825	90	565	1,650	1,700,000	
No. 1 non-dense		1,350	725	90	480	1,550	1,600,000	
No. 2 dense		1,400	675	90	660	1,700	1,700,000	
No. 2		1,200	650	90	565	1,550	1,600,000	
No. 2 non-dense		1,100	600	90	480	1,450	1,400,000	
No. 3		700	400	90	565	875	1,400,000	
Dense select structural	2" to 4" thick 10" wide	2,150	1,200	90	660	2,000	1,900,000	
Select structural		2,050	1,100	90	565	1,850	1,800,000	
Non-dense select structural		1,850	950	90	480	1,750	1,700,000	
No. 1 dense		1,450	775	90	660	1,750	1,800,000	
No. 1		1,300	725	90	565	1,600	1,700,000	
No. 1 non-dense		1,200	650	90	480	1,500	1,600,000	
No. 2 dense		1,200	625	90	660	1,650	1,700,000	
No. 2		1,050	575	90	565	1,500	1,600,000	
No. 2 non-dense		950	550	90	480	1,400	1,400,000	
No. 3		650	325	90	565	850	1,400,000	
Dense select structural	2" to 4" thick 12" wide	2,050	1,100	90	660	1,950	1,900,000	
Select structural		1,900	1,050	90	565	1,800	1,800,000	
Non-dense select structural		1,750	900	90	480	1,700	1,700,000	
No. 1 dense		1,350	725	90	660	1,700	1,800,000	
No. 1		1,250	675	90	565	1,600	1,700,000	
No. 1 non-dense		1,150	600	90	480	1,500	1,600,000	
No. 2 dense		1,150	575	90	660	1,600	1,700,000	
No. 2		975	550	90	565	1,450	1,600,000	
No. 2 non-dense		900	525	90	480	1,350	1,400,000	
No. 3		575	325	90	565	825	1,400,000	

(Continued)

TABLE 23-I-A-2—DESIGN VALUES FOR VISUALLY GRADED SOUTHERN PINE DIMENSION LUMBER—(Continued)

SPECIES AND COMMERICAL GRADE	SIZE CLASSIFICATION  × 25.4 for mm	DESIGN VALUES IN POUNDS PER SQUARE INCH (psi) × 0.00689 for N/mm <sup>2</sup>						GRADING RULES AGENCY
		Bending $F_b$	Tension Parallel to Grain $F_t$	Shear Parallel to Grain $F_v$	Compression Perpendicular to Grain $F_{c\perp}$	Compression Parallel to Grain $F_c$	Modulus of Elasticity $E$	
		(Dry service conditions—19 percent or less moisture content)						
<b>SOUTHERN PINE</b>								
Dense structural 86	2" to 4" thick	2,600	1,750	155	660	2,000	1,800,000	SPIB
Dense structural 72		2,200	1,450	130	660	1,650	1,800,000	
Dense structural 65	2" and wider	2,000	1,300	115	660	1,500	1,800,000	
<b>SOUTHERN PINE</b>								
(Wet service conditions)								
Dense structural 86	2 1/2" to 4" thick	2,100	1,400	145	440	1,300	1,600,000	SPIB
Dense structural 72	2 1/2" and wider	1,750	1,200	120	440	1,100	1,600,000	
Dense structural 65		1,600	1,050	110	440	1,000	1,600,000	

**Notes:**

- Lumber Dimensions.** Tabulated design values are applicable to lumber that will be used under dry conditions such as in most covered structures. For 2-inch- (51 mm) to 4-inch-thick (102 mm) lumber, the DRY dressed sizes shall be used regardless of the moisture content at the time of manufacture or use. In calculating design values, the natural gain in strength and stiffness that occurs as lumber dries has been taken into consideration as well as the reduction in size that occurs when unseasoned lumber shrinks. The gain in load-carrying capacity due to increased strength and stiffness resulting from drying more than offsets the design effect of size reductions due to shrinkage.
- Stress-rated Boards.** Information for various grades of southern pine stress-rated boards of nominal 1-inch (25 mm), 1 1/4-inch (32 mm) and 1 1/2-inch (38 mm) thickness, 2 inches (51 mm) and wider, is available from the Southern Pine Inspection Bureau (SPIB) in the "Standard Grading Rules for Southern Pine Lumber."
- Spruce Pine.** To obtain recommended design values for spruce pine graded to SPIB rules, multiply the appropriate design values for mixed southern pine by the corresponding conversion factor shown below and round to the nearest 100,000 psi (689 N/mm<sup>2</sup>) for  $E$ , to the next lower multiple of 5 psi (0.03 N/mm<sup>2</sup>) for  $F_t$  and  $F_{c\perp}$ ; to the next lower multiple of 50 psi (0.34 N/mm<sup>2</sup>) for  $F_b$ ,  $F_t$  and  $F_c$  if 1,000 psi (6.89 N/mm<sup>2</sup>) or greater, 25 psi (0.17 N/mm<sup>2</sup>) otherwise.

**CONVERSION FACTORS FOR DETERMINING DESIGN VALUES FOR SPRUCE PINE**

	BENDING $F_b$	TENSION PARALLEL TO GRAIN $F_t$	SHEAR PARALLEL TO GRAIN $F_v$	COMPRESSION PERPENDICULAR TO GRAIN $F_{c\perp}$	COMPRESSION PARALLEL TO GRAIN $F_c$	MODULUS OF ELASTICITY $E$
Conversion factor	0.784	0.784	0.965	0.682	0.766	0.807

- Size Factor,  $C_F$ .** Appropriate size adjustment factors have already been incorporated in the tabulated design values for most thicknesses of southern pine and mixed southern pine dimension lumber. For dimension lumber 4 inches (102 mm) thick, 8 inches (203 mm) and wider (all grades except dense structural 86, dense structural 72 and dense structural 65), tabulated bending design values,  $F_b$ , shall be permitted to be multiplied by the size factor,  $C_F = 1.1$ . For dimension lumber wider than 12 inches (305 mm) (all grades except dense structural 86, dense structural 72 and dense structural 65), tabulated bending, tension and compression-parallel-to-grain design values for 12-inch-wide (305 mm) lumber shall be multiplied by the size factor,  $C_F = 0.9$ . When the depth,  $d$ , of dense structural 86, dense structural 72 or dense structural 65 dimension lumber exceeds 12 inches (305 mm), the tabulated bending design value,  $F_b$ , shall be multiplied by the following size factor:

$$C_F = (12/d)^{1/9}$$

$$\text{For SI: } C_F = (304.8/d)^{1/9}$$

5. **Repetitive Member Factor,  $C_r$ .** Bending design values,  $F_b$ , for dimension lumber 2 inches (51 mm) to 4 inches (102 mm) thick shall be multiplied by the repetitive member factor,  $C_r = 1.15$ , when such members are used as joists, truss chords, rafters, studs, planks, decking or similar members which are in contact or spaced not more than 24 inches (610 mm) on center, are not less than three in number and are joined by floor, roof or other load-distributing elements adequate to support the design load.
6. **Flat-use Factor,  $C_{fu}$ .** Bending design values adjusted by size factors are based on edgewise use (load applied to narrow face). When dimension lumber is used flatwise (load applied to wide face), the bending design value,  $F_b$ , shall also be multiplied by the following flat-use factors:

**FLAT-USE FACTORS,  $C_{fu}$**

WIDTH × 25.4 for mm	THICKNESS	
	2" and 3" (51 mm and 76 mm)	4" (102 mm)
2" and 3"	1.0	—
4"	1.1	1.0
5"	1.1	1.05
6"	1.15	1.05
8"	1.15	1.05
10" and wider	1.2	1.1

7. **Wet Service Factor,  $C_M$ .** When dimension lumber is used where moisture content will exceed 19 percent for an extended time period, design values shall be multiplied by the appropriate wet service factors from the following table (for dense structural 86, dense structural 72 and dense structural 65 use tabulated design values for wet service conditions without further adjustment):

**WET SERVICE FACTORS,  $C_M$**

$F_b$	$F_t$	$F_v$	$F_{c\perp}$	$F_c$	$E$
0.85*	1.0	0.97	0.67	0.8**	0.9

\*when  $(F_b)(C_F) \leq 1,150$  psi (7.92 N/mm<sup>2</sup>),  $C_M = 1.0$

\*\*when  $F_c \leq 750$  psi (5.17 N/mm<sup>2</sup>),  $C_M = 1.0$

8. **Shear Stress Factor,  $C_H$ .** Tabulated shear design values parallel to grain have been reduced to allow for the occurrence of splits, checks and shakes. Tabulated shear design values parallel to grain,  $F_v$ , shall be permitted to be multiplied by the shear stress factors specified in the following table when length of split, or size of check or shake is known and no increase in them is anticipated. When shear stress factors are used for southern pine and mixed southern pine, a tabulated design value of  $F_v = 90$  psi (0.62 N/mm<sup>2</sup>) shall be assigned for all grades of southern pine and mixed southern pine dimension lumber. Shear stress factors shall be permitted to be linearly interpolated.

**SHEAR STRESS FACTORS,  $C_H$**

Length of split on wide face of 2-inch (51 mm) (nominal) lumber	$C_H$	Length of split on wide face of 3-inch (76 mm) and thicker lumber	$C_H$	Size of shake* in 2-inch (51 mm) (nominal) and thicker lumber	$C_H$
no split	2.00	no split	2.00	no shake	2.00
1/2 by wide face	1.67	1/2 by narrow face	1.67	1/6 by narrow face	1.67
3/4 by wide face	1.50	3/4 by narrow face	1.50	1/4 by narrow face	1.50
1 by wide face	1.33	1 by narrow face	1.33	1/3 by narrow face	1.33
1 1/2 by wide face or more	1.00	1 1/2 by narrow face or more	1.00	1/2 by narrow face or more	1.00
				*Shake is measured at the end between lines enclosing the shake and perpendicular to the loaded face.	

**TABLE 23-I-A-3—DESIGN VALUES FOR MECHANICALLY GRADED DIMENSION LUMBER**  
(Tabulated design values are for normal load duration and dry service conditions.)

SPECIES AND COMMERCIAL GRADE	SIZE CLASSIFICATION  × 25.4 for mm	DESIGN VALUES IN POUNDS PER SQUARE INCH (psi) × 0.00689 for mm				GRADING RULES AGENCY
		Bending $F_b$	Tension Parallel to Grain $F_t$	Compression Parallel to Grain $F_c$	Modulus of Elasticity $E$	
		<b>MACHINE STRESS-RATED (MSR) LUMBER</b>				
900f-1.0E		900	350	1,050	1,000,000	WCLIB, WWPA
1200f-1.2E		1,200	600	1,400	1,200,000	NLGA, SPIB, WCLIB, WWPA
1350f-1.3E		1,350	750	1,600	1,300,000	SPIB, WCLIB, WWPA
1450f-1.3E		1,450	800	1,625	1,300,000	NLGA, WCLIB, WWPA
1500f-1.3E		1,500	900	1,650	1,300,000	SPIB
1500f-1.4E		1,500	900	1,650	1,400,000	NLGA, SPIB, WCLIB, WWPA
1650f-1.4E		1,650	1,020	1,700	1,400,000	SPIB
1650f-1.5E		1,650	1,020	1,700	1,500,000	NLGA, SPIB, WCLIB, WWPA
1800f-1.6E		1,800	1,175	1,750	1,600,000	NLGA, SPI, WCLIB, WWPA
1950f-1.5E	2" and less in thickness	1,950	1,375	1,800	1,500,000	SPIB
1950f-1.7E		1,950	1,375	1,800	1,700,000	NLGA, SPIB, WWPA
2100f-1.8E		2,100	1,575	1,875	1,800,000	NLGA, SPIB, WCLIB, WWPA
2250f-1.6E	2" and wider	2,250	1,750	1,925	1,600,000	SPIB
2250f-1.9E		2,250	1,750	1,925	1,900,000	NLGA, SPIB, WWPA
2400f-1.7E		2,400	1,925	1,975	1,700,000	SPIB
2400f-2.0E		2,400	1,925	1,975	2,000,000	NLGA, SPIB, WCLIB, WWPA
2550f-2.1E		2,550	2,050	2,025	2,100,000	NLGA, SPIB, WWPA
2700f-2.2E		2,700	2,150	2,100	2,200,000	NLGA, SPIB, WCLIB, WWPA
2850f-2.3E		2,850	2,300	2,150	2,300,000	SPIB, WWPA
3000f-2.4E		3,000	2,400	2,200	2,400,000	NLGA, SPIB
3150f-2.5E		3,150	2,500	2,250	2,500,000	SPIB
3300f-2.6E		3,300	2,650	2,325	2,600,000	SPIB
900f-1.2E	2" and less in thickness	900	350	1,050	1,200,000	NLGA, WCLIB
1200f-1.5E		1,200	600	1,400	1,500,000	NLGA, WCLIB
1350f-1.8E		1,350	750	1,600	1,800,000	NLGA
1500f-1.8E		1,500	900	1,650	1,800,000	WCLIB
1800f-2.1E	6" and wider	1,800	1,175	1,750	2,100,000	NLGA, WCLIB

MACHINE EVALUATED LUMBER (MEL)						
M-10		1,400	800	1,600	1,200,000	
M-11		1,550	850	1,650	1,500,000	
M-12		1,600	850	1,700	1,600,000	
M-13		1,600	950	1,700	1,400,000	
M-14		1,800	1,000	1,750	1,700,000	
M-15		1,800	1,100	1,750	1,500,000	
M-16		1,800	1,300	1,750	1,500,000	
M-17	2" and less in thickness	1,950	1,300	2,050	1,700,000	
M-18		2,000	1,200	1,850	1,800,000	
M-19		2,000	1,300	1,850	1,600,000	
M-20	2" and wider	2,000	1,600	2,100	1,900,000	
M-21		2,300	1,400	1,950	1,900,000	
M-22		2,350	1,500	1,950	1,700,000	
M-23		2,400	1,900	2,000	1,800,000	
M-24		2,700	1,800	2,100	1,900,000	
M-25		2,750	2,000	2,100	2,200,000	
M-26		2,800	1,800	2,150	2,000,000	
M-27		3,000	2,000	2,400	2,100,000	

SPIB

**Notes:**

- Lumber Dimensions.** Tabulated design values are applicable to lumber that will be used under dry conditions such as in most covered structures. For 2-inch- (51 mm) to 4-inch-thick (102 mm) lumber, the DRY dressed sizes shall be used regardless of the moisture content at the time of manufacture or use. In calculating design values, the natural gain in strength and stiffness that occurs as lumber dries has been taken into consideration as well as the reduction in size that occurs when unseasoned lumber shrinks. The gain in load-carrying capacity due to increased strength and stiffness resulting from drying more than offsets the design effect of size reductions due to shrinkage.
- Shear Parallel to Grain,  $F_v$ , and Compression Perpendicular to Grain,  $F_{c\perp}$ .** Design values for shear parallel to grain,  $F_v$ , and compression perpendicular to grain,  $F_{c\perp}$ , are identical to the design values given in Tables 23-I-A-1 and 23-I-A-2 for No. 2 visually graded lumber of the appropriate species.
- Modulus of Elasticity,  $E$ .** For any given bending design value,  $F_b$ , the average modulus of elasticity,  $E$ , may vary depending on species, timber source or other variables. The  $E$  value included in the  $F_b$ - $E$  grade designations in Table 23-I-A-3 are those usually associated with each  $F_b$  level. Grade stamps may show higher or lower  $E$  values [in increments of 100,000 psi (689 N/mm<sup>2</sup>)] if machine rating indicates the assignment is appropriate. When the  $E$  value shown on a grade stamp differs from the  $E$  value in Table 23-I-A-3, the  $E$  value shown on the grade stamp shall be used for design. The tabulated  $F_b$ ,  $F_t$  and  $F_c$  values associated with the designated  $F_b$  value shall be used for design.
- Repetitive Member Factor,  $C_r$ .** Bending design values,  $F_b$ , for dimension lumber 2 inches to 4 inches (51 mm to 102 mm) thick shall be multiplied by the repetitive member factor.  $C_r = 1.15$ , when such members are used as joists, truss chords, rafters, studs, planks, decking or similar members which are in contact or spaced not more than 24 inches (610 mm) on center, are not less than three in number and are joined by floor, roof or other load-distributing elements adequate to support the design load.

(Continued)

NOTES TO TABLE 23-1-A-3—(Continued)

5. **Flat-use Factor,  $C_{Fu}$ .** Bending design values adjusted by size factors are based on edgewise use (load applied to narrow face). When dimension lumber is used flatwise (load applied to wide face), the bending design value,  $F_b$ , shall also be multiplied by the following flat-use factors:

FLAT-USE FACTORS,  $C_{Fu}$

WIDTH	THICKNESS
× 25.4 for mm	2" (51 mm)
2" and 3"	1.0
4"	1.1
5"	1.1
6"	1.15
8"	1.15
10" and wider	1.2

6. **Wet Service Factor,  $C_M$ .** When dimension lumber is used where moisture content will exceed 19 percent for an extended time period, design values shall be multiplied by the appropriate wet service factors from the following table:

WET SERVICE FACTORS,  $C_M$

$F_b$	$F_t$	$F_v$	$F_{c\perp}$	$F_c$	$E$
0.85*	1.0	0.97	0.67	0.8	0.9

\*when  $F_b \leq 1,150$  psi (7.92 N/mm<sup>2</sup>),  $C_M = 1.0$

7. **Shear Stress Factor,  $C_H$ .** Tabulated shear design values parallel to grain have been reduced to allow for the occurrence of splits, checks and shakes. Tabulated shear design values parallel to grain,  $F_v$ , shall be permitted to be multiplied by the shear stress factors specified in the following table when length of split, or size of check or shake is known and no increase in them is anticipated. Shear stress factors shall be permitted to be linearly interpolated.

SHEAR STRESS FACTORS,  $C_H$

Length of split on wide face of 2-inch (51 mm) (nominal) lumber	$C_H$	Length of split on wide face of 3-inch (76 mm) (nominal) and thicker lumber	$C_H$	Size of shake* in 2-inch (51 mm) (nominal) and thicker lumber	$C_H$
no split	2.00	no split	2.00	no shake	2.00
1/2 by wide face	1.67	1/2 by narrow face	1.67	1/6 by narrow face	1.67
3/4 by wide face	1.50	3/4 by narrow face	1.50	1/4 by narrow face	1.50
1 by wide face	1.33	1 by narrow face	1.33	1/3 by narrow face	1.33
1 1/2 by wide face or more	1.00	1 1/2 by narrow face or more	1.00	1/2 by narrow face or more	1.00
				*Shake is measured at the end between lines enclosing the shake and perpendicular to the loaded face.	

**TABLE 23-I-A-4—DESIGN VALUES FOR VISUALLY GRADED TIMBERS [5 inches by 5 inches (127 mm by 127 mm) and larger]  
(Tabulated design values are for normal load duration and dry service conditions, unless specified otherwise.)**

SPECIES AND COMMERCIAL GRADE	SIZE CLASSIFICATION	DESIGN VALUES IN POUNDS PER SQUARE INCH (psi)						GRADING RULES AGENCY
		× 0.00689 for N/mm <sup>2</sup>						
		Bending $F_b$	Tension Parallel to Grain $F_t$	Shear Parallel to Grain $F_v$	Compression Perpendicular to Grain $F_{c\perp}$	Compression Parallel to Grain $F_c$	Modulus of Elasticity $E$	
<b>BALSAM FIR</b>								
Select structural	Beams and stringers	1,350	900	65	305	950	1,400,000	NELMA NSLB
No. 1		1,100	750	65	305	800	1,400,000	
No. 2		725	350	65	305	500	1,100,000	
Select structural	Posts and timbers	1,250	825	65	305	1,000	1,400,000	
No. 1		1,000	675	65	305	875	1,400,000	
No. 2		575	375	65	305	400	1,100,000	
<b>BEECH-BIRCH-HICKORY</b>								
Select structural	Beams and stringers	1,650	975	90	715	975	1,500,000	NELMA
No. 1		1,400	700	90	715	825	1,500,000	
No. 2		900	450	90	715	525	1,200,000	
Select structural	Posts and timbers	1,550	1,050	90	715	1,050	1,500,000	
No. 1		1,250	850	90	715	900	1,500,000	
No. 2		725	475	90	715	425	1,200,000	
<b>COAST SITKA SPRUCE</b>								
Select structural	Beams and stringers	1,150	675	60	455	775	1,500,000	NLGA
No. 1		950	475	60	455	650	1,500,000	
No. 2		625	325	60	455	425	1,200,000	
Select structural	Posts and timbers	1,100	725	60	455	825	1,500,000	
No. 1		875	575	60	455	725	1,500,000	
No. 2		525	350	60	455	500	1,200,000	
<b>DOUGLAS FIR-LARCH</b>								
Dense select structural	Beams and stringers	1,900	1,100	85	730	1,300	1,700,000	WCLIB
Select structural		1,600	950	85	625	1,100	1,600,000	
Dense No. 1		1,550	775	85	730	1,100	1,700,000	
No. 1		1,350	675	85	625	925	1,600,000	
No. 2		875	425	85	625	600	1,300,000	

(Continued)

TABLE 23-I-A-4—DESIGN VALUES FOR VISUALLY GRADED TIMBERS [5 inches by 5 inches (127 mm by 127 mm) and larger]—(Continued)

SPECIES AND COMMERCIAL GRADE	SIZE CLASSIFICATION	DESIGN VALUES IN POUNDS PER SQUARE INCH (psi)						GRADING RULES AGENCY
		× 0.00689 for N/mm <sup>2</sup>						
		Bending $F_b$	Tension Parallel to Grain $F_t$	Shear Parallel to Grain $F_v$	Compression Perpendicular to Grain $F_{c\perp}$	Compression Parallel to Grain $F_c$	Modulus of Elasticity $E$	
<b>DOUGLAS FIR-LARCH (continued)</b>								
Dense select structural	Posts and timbers	1,750	1,150	85	730	1,350	1,700,000	WCLIB
Select structural		1,500	1,000	85	625	1,150	1,600,000	
Dense No. 1		1,400	950	85	730	1,200	1,700,000	
No. 1		1,200	825	85	625	1,000	1,600,000	
No. 2		750	475	85	625	700	1,300,000	
Dense select structural	Beams and stringers	1,850	1,110	85	730	1,300	1,700,000	WWPA
Select structural		1,600	950	85	625	1,100	1,600,000	
Dense No. 1		1,550	775	85	730	1,100	1,700,000	
No. 1		1,350	675	85	625	925	1,600,000	
Dense No. 2		1,000	500	85	730	700	1,400,000	
No. 2	875	425	85	625	600	1,300,000		
Dense select structural	Posts and timbers	1,750	1,150	85	730	1,350	1,700,000	WWPA
Select structural		1,500	1,000	85	625	1,150	1,600,000	
Dense No. 1		1,400	950	85	730	1,200	1,700,000	
No. 1		1,200	825	85	625	1,000	1,600,000	
Dense No. 2		800	550	85	730	550	1,400,000	
No. 2	700	475	85	625	475	1,300,000		
<b>DOUGLAS FIR-LARCH (North)</b>								
Select structural	Beams and stringers	1,600	950	85	625	1,100	1,600,000	NLGA
No. 1		1,300	675	85	625	925	1,600,000	
No. 2		875	425	85	625	600	1,300,000	
Select structural	Posts and timbers	1,500	1,000	85	625	1,150	1,600,000	NLGA
No. 1		1,200	825	85	625	1,000	1,600,000	
No. 2		725	475	85	625	700	1,300,000	
<b>DOUGLAS FIR SOUTH</b>								

Select structural No. 1	Beams and stringers	1,550	900	85	520	1,000	1,200,000	WWPA
No. 2		1,300	625	85	520	850	1,200,000	
		825	425	85	520	525	1,000,000	
Select structural No. 1	Posts and timbers	1,400	950	85	520	1,050	1,200,000	
No. 2		1,150	775	85	520	825	1,200,000	
		650	400	85	520	425	1,000,000	
<b>EASTERN HEMLOCK</b>								
Select structural No. 1	Beams and stringers	1,350	925	80	550	950	1,200,000	NELMA NSLB
No. 2		1,150	775	80	550	800	1,200,000	
		750	375	80	550	550	900,000	
Select structural No. 1	Posts and timbers	1,250	850	80	550	1,000	1,200,000	
No. 2		1,050	700	80	550	875	1,200,000	
		600	400	80	550	400	900,000	
<b>EASTERN HEMLOCK-TAMARACK</b>								
Select structural No. 1	Beams and stringers	1,400	925	80	555	950	1,200,000	NELMA NSLB
No. 2		1,150	775	80	555	800	1,200,000	
		750	375	80	555	500	900,000	
Select structural No. 1	Posts and timbers	1,300	875	80	555	1,000	1,200,000	
No. 2		1,050	700	80	555	875	1,200,000	
		600	400	80	555	400	900,000	
<b>EASTERN HEMLOCK-TAMARACK (North)</b>								
Select structural No. 1	Beams and stringers	1,450	850	85	555	950	1,300,000	NLGA
No. 2		1,200	600	85	555	800	1,300,000	
		775	400	85	555	500	1,100,000	
Select structural No. 1	Posts and timbers	1,350	900	85	555	1,000	1,300,000	
No. 2		1,100	725	85	555	875	1,300,000	
		650	425	85	555	600	1,100,000	
<b>EASTERN SPRUCE</b>								
Select structural No. 1	Beams and stringers	1,050	725	65	390	750	1,400,000	NELMA NSLB
No. 2		900	600	65	390	625	1,400,000	
		575	275	65	390	375	1,000,000	
Select structural No. 1	Posts and timbers	1,000	675	65	390	775	1,400,000	
No. 2		800	550	65	390	675	1,400,000	
		450	300	65	390	300	1,000,000	

EASTERN WHITE PINE								NELMA NSLB
Select structural		1,050	700	65	350	675	1,100,000	
No. 1	Beams and stringers	875	600	65	350	575	1,100,000	
No. 2		575	275	65	350	400	900,000	
Select structural			975	650	65	350	725	
No. 1	Posts and timbers	800	525	65	350	625	1,100,000	
No. 2		450	300	65	350	325	900,000	

(Continued)

TABLE 23-I-A-4—DESIGN VALUES FOR VISUALLY GRADED TIMBERS [5 inches by 5 inches (127 mm by 127 mm) and larger]—(Continued)

SPECIES AND COMMERCIAL GRADE	SIZE CLASSIFICATION	DESIGN VALUES IN POUNDS PER SQUARE INCH (psi)						GRADING RULES AGENCY
		× 0.00689 for N/mm <sup>2</sup>						
		Bending $F_b$	Tension Parallel to Grain $F_t$	Shear Parallel to Grain $F_v$	Compression Perpendicular to Grain $F_{c\perp}$	Compression Parallel to Grain $F_c$	Modulus of Elasticity $E$	
<b>HEM-FIR</b>								
Select structural No. 1 No. 2	Beams and stringers	1,300	750	70	405	925	1,300,000	WCLIB
		1,050	525	70	405	750	1,300,000	
		675	350	70	405	500	1,100,000	
Select structural No. 1 No. 2	Posts and timbers	1,200	800	70	405	975	1,300,000	
		975	650	70	405	850	1,300,000	
		575	375	70	405	575	1,100,000	
Select structural No. 1 No. 2	Beams and stringers	1,250	725	70	405	925	1,300,000	WWPA
		1,050	525	70	405	775	1,300,000	
		675	325	70	405	475	1,100,000	
Select structural No. 1 No. 2	Posts and timbers	1,200	800	70	405	975	1,300,000	
		950	650	70	405	850	1,300,000	
		525	350	70	405	375	1,100,000	
<b>HEM-FIR (North)</b>								
Select structural No. 1 No. 2	Beams and stringers	1,250	725	70	370	900	1,300,000	NLGA
		1,000	500	70	370	750	1,300,000	
		675	325	70	370	475	1,100,000	
Select structural No. 1 No. 2	Posts and timbers	1,150	775	70	370	950	1,300,000	
		925	625	70	370	850	1,300,000	
		550	375	70	370	575	1,100,000	
<b>MIXED MAPLE</b>								
Select structural No. 1 No. 2	Beams and stringers	1,150	700	90	620	725	1,100,000	NELMA
		975	500	90	620	600	1,100,000	
		625	325	90	620	375	900,000	
Select structural No. 1 No. 2	Posts and timbers	1,100	725	90	620	750	1,100,000	
		875	600	90	620	650	1,100,000	
		500	350	90	620	300	900,000	
<b>MIXED OAK</b>								
Select structural No. 1 No. 2	Beams and stringers	1,350	800	80	800	825	1,000,000	NELMA
		1,150	550	80	800	700	1,000,000	
		725	375	80	800	450	800,000	

Select structural No. 1 No. 2	Posts and timbers	1,250 1,000 575	850 675 400	80 80 80	800 800 800	875 775 350	1,000,000 1,000,000 800,000	NELMA
<b>MIXED SOUTHERN PINE (Wet Service Conditions)</b>								
Select structural SR No. 1 SR No. 2 SR	5" x 5" and larger (127 mm x 127 mm)	1,500 1,350 850	1,000 900 550	110 110 95	375 375 375	900 800 525	1,300,000 1,300,000 1,000,000	SPIB
<b>MOUNTAIN HEMLOCK</b>								
Select structural No. 1 No. 2	Beams and stringers	1,350 1,100 725	775 550 375	85 85 85	570 570 570	875 725 475	1,100,000 1,100,000 900,000	WCLIB
Select structural No. 1 No. 2	Posts and timbers	1,250 1,000 625	825 675 400	85 85 85	570 570 570	925 800 550	1,100,000 1,100,000 900,000	
<b>NORTHERN PINE</b>								
Select structural No. 1 No. 2	Beams and stringers	1,250 1,050 675	850 700 350	65 65 65	435 435 435	850 725 450	1,300,000 1,300,000 1,000,000	NELMA NSLB
Select structural No. 1 No. 2	Posts and timbers	1,150 950 550	800 650 375	65 65 65	435 435 435	900 800 375	1,300,000 1,300,000 1,000,000	
<b>NORTHERN RED OAK</b>								
Select structural No. 1 No. 2	Beams and stringers	1,600 1,350 875	950 675 425	105 105 105	885 885 885	950 800 500	1,300,000 1,300,000 1,000,000	NELMA
Select structural No. 1 No. 2	Posts and timbers	1,500 1,200 700	1,000 800 475	105 105 105	885 885 885	1,000 875 400	1,300,000 1,300,000 1,000,000	
<b>NORTHERN WHITE CEDAR</b>								
Select structural No. 1 No. 2	Beams and stringers	900 750 500	600 500 250	60 60 60	370 370 370	600 500 325	700,000 700,000 600,000	NELMA
Select structural No. 1 No. 2	Posts and timbers	850 675 400	575 450 250	60 60 60	370 370 370	650 550 250	700,000 700,000 600,000	

(Continued)

TABLE 23-I-A-4—DESIGN VALUES FOR VISUALLY GRADED TIMBERS [5 inches by 5 inches (127 mm by 127 mm) and larger]—(Continued)

SPECIES AND COMMERICAL GRADE	SIZE CLASSIFICATION	DESIGN VALUES IN POUNDS PER SQUARE INCH (psi)						GRADING RULES AGENCY
		× 0.00689 for N/mm <sup>2</sup>						
		Bending $F_b$	Tension Parallel to Grain $F_t$	Shear Parallel to Grain $F_v$	Compression Perpendicular to Grain $F_{c\perp}$	Compression Parallel to Grain $F_c$	Modulus of Elasticity $E$	
<b>PONDEROSA PINE</b>								
Select structural	Beams and stringers	1,100	725	65	535	750	1,100,000	NLGA
No. 1		925	500	65	535	625	1,100,000	
No. 2		600	300	65	535	400	900,000	
Select structural	Posts and timbers	1,000	675	65	535	800	1,100,000	
No. 1		825	550	65	535	700	1,100,000	
No. 2		475	325	65	535	325	900,000	
<b>RED MAPLE</b>								
Select structural	Beams and stringers	1,500	875	100	615	900	1,500,000	NELMA
No. 1		1,250	625	100	615	750	1,500,000	
No. 2		800	400	100	615	475	1,200,000	
Select structural	Posts and timbers	1,400	925	100	615	950	1,500,000	
No. 1		1,150	750	100	615	825	1,500,000	
No. 2		650	425	100	615	375	1,200,000	
<b>RED OAK</b>								
Select structural	Beams and stringers	1,350	800	80	820	825	1,200,000	NELMA
No. 1		1,150	550	80	820	700	1,200,000	
No. 2		725	375	80	820	450	1,000,000	
Select structural	Posts and timbers	1,250	850	80	820	875	1,200,000	
No. 1		1,000	675	80	820	775	1,200,000	
No. 2		575	400	80	820	350	1,000,000	
<b>RED PINE</b>								
Select structural	Beams and stringers	1,050	625	65	440	725	1,100,000	NLGA
No. 1		875	450	65	440	600	1,100,000	
No. 2		575	300	65	440	375	900,000	
Select structural	Posts and timbers	1,000	675	65	440	775	1,100,000	
No. 1		800	550	65	440	675	1,100,000	
No. 2		475	325	65	440	475	900,000	

<b>REDWOOD</b>								
Clear heart structural or clear structural	5" × 5" and larger (127 mm × 127 mm)	1,850	1,250	135	650	1,650	1,300,000	RIS
Select structural No. 1		1,400	950	95	650	1,200	1,300,000	
No. 2		1,200	800	95	650	1,050	1,300,000	
		975	650	95	650	900	1,100,000	
<b>SITKA SPRUCE</b>								
Select structural No. 1	Beams and stringers	1,200	675	70	435	825	1,300,000	WCLIB
No. 2		1,000	500	70	435	675	1,300,000	
		650	325	70	435	450	1,000,000	
Select structural No. 1	Posts and timbers	1,150	750	70	435	875	1,300,000	
No. 2		925	600	70	435	750	1,300,000	
		550	350	70	435	525	1,000,000	
<b>SOUTHERN PINE (Wet Service Conditions)</b>								
Dense select structural SR	5" × 5" and larger (127 mm × 127 mm)	1,750	1,200	110	440	1,100	1,600,000	SPIB
Select structural SR		1,500	1,000	110	375	950	1,500,000	
No. 1 dense SR		1,550	1,050	110	440	975	1,600,000	
No. 1 SR		1,350	875	110	375	825	1,500,000	
No. 2 dense SR		975	650	100	440	625	1,300,000	
No. 2 SR		850	550	100	375	525	1,200,000	
Dense structural 86		2,100	1,400	145	440	1,300	1,600,000	
Dense structural 72		1,750	1,200	120	440	1,100	1,600,000	
Dense structural 65		1,600	1,050	110	440	1,000	1,600,000	
<b>SPRUCE-PINE-FIR</b>								
Select structural No. 1	Beams and stringers	1,100	650	65	425	775	1,300,000	NLGA
No. 2		900	450	65	425	625	1,300,000	
		600	300	65	425	425	1,000,000	
Select structural No. 1	Posts and timbers	1,050	700	65	425	800	1,300,000	
No. 2		850	550	65	425	700	1,300,000	
		500	325	65	425	500	1,000,000	

(Continued)

**TABLE 23-I-A-4—DESIGN VALUES FOR VISUALLY GRADED TIMBERS [5 inches by 5 inches (127 mm by 127 mm) and larger]—(Continued)**

SPECIES AND COMMERCIAL GRADE	SIZE CLASSIFICATION	DESIGN VALUES IN POUNDS PER SQUARE INCH (psi)						GRADING RULES AGENCY
		× 0.00689 for N/mm <sup>2</sup>						
		Bending $F_b$	Tension Parallel to Grain $F_t$	Shear Parallel to Grain $F_v$	Compression Perpendicular to Grain $F_{c\perp}$	Compression Parallel to Grain $F_c$	Modulus of Elasticity $E$	
<b>SPRUCE-PINE-FIR (South)</b>								
Select structural	Beams and stringers	1,050	625	65	335	675	1,200,000	NELMA NSLB
No. 1		900	450	65	335	575	1,200,000	
No. 2		575	300	65	335	350	1,000,000	
Select structural	Posts and timbers	1,000	675	65	335	700	1,200,000	WWPA
No. 1		800	550	65	335	625	1,200,000	
No. 2		350	225	65	335	225	1,000,000	
<b>WESTERN CEDARS</b>								
Select structural	Beams and stringers	1,150	675	70	425	875	1,000,000	WCLIB
No. 1		975	475	70	425	725	1,000,000	
No. 2		625	325	70	425	475	800,000	
Select structural	Posts and timbers	1,100	725	70	425	925	1,000,000	WWPA
No. 1		875	600	70	425	800	1,000,000	
No. 2		550	350	70	425	550	800,000	
Select structural	Beams and stringers	1,150	700	70	425	875	1,000,000	WWPA
No. 1		975	475	70	425	725	1,000,000	
No. 2		625	325	70	425	475	800,000	
Select structural	Posts and timbers	1,100	725	70	425	925	1,000,000	WWPA
No. 1		875	600	70	425	800	1,000,000	
No. 2		500	350	70	425	375	800,000	
<b>WESTERN CEDARS (North)</b>								
Select structural	Beams and stringers	1,150	675	65	425	850	1,000,000	NI GA
No. 1		925	475	65	425	700	1,000,000	
No. 2		625	300	65	425	450	800,000	
Select structural	Posts and timbers	1,050	700	65	425	900	1,000,000	NI GA
No. 1		875	575	65	425	800	1,000,000	
No. 2		500	350	65	425	550	800,000	
<b>WESTERN HEMLOCK</b>								
Select structural	Beams and stringers	1,400	825	85	410	1,000	1,400,000	WCLIB
No. 1		1,150	575	85	410	850	1,400,000	
No. 2		750	375	85	410	550	1,100,000	

Select structural No. 1 No. 2	Posts and timbers	1,300 1,050 650	875 700 425	85 85 85	410 410 410	1,100 950 650	1,400,000 1,400,000 1,100,000	WCLIB
<b>WESTERN HEMLOCK (North)</b>								
Select structural No. 1 No. 2	Beams and stringers	1,400 1,150 750	825 575 375	70 70 70	410 410 410	1,000 850 550	1,400,000 1,400,000 1,100,000	NLGA
Select structural No. 1 No. 2	Posts and timbers	1,300 1,050 650	875 700 425	70 70 70	410 410 410	1,100 950 650	1,400,000 1,400,000 1,100,000	
<b>WESTERN WHITE PINE</b>								
Select structural No. 1 No. 2	Beams and stringers	1,050 850 550	600 425 275	60 60 60	375 375 375	775 625 400	1,300,000 1,300,000 1,000,000	NLGA
Select structural No. 1 No. 2	Posts and timbers	975 775 450	650 525 300	60 60 60	375 375 375	800 700 500	1,300,000 1,300,000 1,000,000	
<b>WESTERN WOODS</b>								
Select structural No. 1 No. 2	Beams and stringers	1,050 900 575	625 450 300	65 65 65	335 335 335	675 575 350	1,100,000 1,100,000 900,000	WWPA
Select structural No. 1 No. 2	Posts and timbers	1,000 800 350	675 550 225	65 65 65	335 335 335	700 625 225	1,100,000 1,100,000 900,000	
<b>WHITE OAK</b>								
Select structural No. 1 No. 2	Beams and stringers	1,400 1,200 750	825 575 375	105 105 105	800 800 800	900 775 475	1,000,000 1,000,000 800,000	NELMA
Select structural No. 1 No. 2	Posts and timbers	1,300 1,050 600	875 700 400	105 105 105	800 800 800	950 825 400	1,000,000 1,000,000 800,000	

**Notes:**

1. **Lumber Dimensions.** Tabulated design values are applicable to lumber that will be used under dry conditions such as in most covered structures. For 5-inch (127 mm) and thicker lumber, the GREEN dressed sizes shall be permitted to be used (see Table 23-I-A-1) because design values have been adjusted to compensate for any loss in size by shrinkage which may occur.

(Continued)

**NOTES TO TABLE 23-I-A-4—(Continued)**

2. **Spruce Pine.** To obtain recommended design values for spruce pine graded to Southern Pine Inspection Bureau (SPIB) rules, multiply the appropriate design values for mixed southern pine by the corresponding conversion factor shown below and round to the nearest 100,000 psi (689 N/mm<sup>2</sup>) for *E*, to the next lower multiple of 5 psi (0.03 N/mm<sup>2</sup>) for *F<sub>v</sub>* and *F<sub>c⊥</sub>*; to the next lower multiple of 50 psi (0.34 N/mm<sup>2</sup>) for *F<sub>b</sub>*, *F<sub>t</sub>* and *F<sub>c</sub>* if 1,000 psi (6.89 N/mm<sup>2</sup>) or greater, 25 psi (0.17 N/mm<sup>2</sup>) otherwise.

**CONVERSION FACTORS FOR DETERMINING DESIGN VALUES FOR SPRUCE PINE**

	BENDING <i>F<sub>b</sub></i>	TENSION PARALLEL TO GRAIN <i>F<sub>t</sub></i>	SHEAR PARALLEL TO GRAIN <i>F<sub>v</sub></i>	COMPRESSION PERPENDICULAR TO GRAIN <i>F<sub>c⊥</sub></i>	COMPRESSION PARALLEL TO GRAIN <i>F<sub>c</sub></i>	MODULUS OF ELASTICITY <i>E</i>
Conversion factor	0.784	0.784	0.965	0.682	0.766	0.807

3. **Size Factor, *C<sub>F</sub>*.** When the depth, *d*, of a beam, stringer, post or timber exceeds 12 inches (305 mm), the tabulated bending design value, *F<sub>b</sub>*, shall be multiplied by the following size factor:

$$C_F = (12/d)^{1/9}$$

For SI:  $C_F = (304.8/d)^{1/9}$

4. **Wet Service Factor, *C<sub>M</sub>*.** When timbers are used where moisture content will exceed 19 percent for an extended time period, design values shall be multiplied by the appropriate wet service factors from the following table (for southern pine and mixed southern pine use tabulated design values without further adjustment):

**WET SERVICE FACTORS, *C<sub>M</sub>***

<i>F<sub>b</sub></i>	<i>F<sub>t</sub></i>	<i>F<sub>v</sub></i>	<i>F<sub>c⊥</sub></i>	<i>F<sub>c</sub></i>	<i>E</i>
1.00	1.00	1.00	0.67	0.91	1.00

5. **Shear Stress Factor, *C<sub>H</sub>*.** Tabulated shear design values parallel to grain have been reduced to allow for the occurrence of splits, checks and shakes. Tabulated shear design values parallel to grain, *F<sub>v</sub>*, shall be permitted to be multiplied by the shear stress factors specified in the following table when length of split, or size of check or shake is known and no increase in them is anticipated. When shear stress factors are used for redwood, southern pine and mixed southern pine, a tabulated design value of *F<sub>v</sub>* = 80 psi (0.55 N/mm<sup>2</sup>) shall be assigned for all grades of redwood and a tabulated design value of *F<sub>v</sub>* = 90 psi (0.62 N/mm<sup>2</sup>) shall be assigned for all grades of southern pine and mixed southern pine. Shear stress factors shall be permitted to be linearly interpolated.

**SHEAR STRESS FACTORS, *C<sub>H</sub>***

Length of split on wide face of 5-inch (127 mm) (nominal) and thicker lumber	<i>C<sub>H</sub></i>	Size of shake* in 5-inch (127 mm) (nominal) and thicker lumber	<i>C<sub>H</sub></i>
no split	2.00	no shake	2.00
1/2 by narrow face	1.67	1/6 by narrow face	1.67
3/4 by narrow face	1.50	1/4 by narrow face	1.50
1 by narrow face	1.33	1/3 by narrow face	1.33
1 1/2 by narrow face or more	1.00	1/2 by narrow face or more	1.00
		*Shake is measured at the end between lines enclosing the shake and perpendicular to the loaded face.	

**TABLE 23-I-A-5—DESIGN VALUES FOR VISUALLY GRADED DECKING**  
 (Tabulated design values are for normal load duration and dry service conditions, unless specified otherwise.)

SPECIES AND COMMERCIAL GRADE	SIZE CLASSIFICATION × 25.4 for mm	DESIGN VALUES IN POUNDS PER SQUARE INCH (psi) × 0.00689 for N/mm <sup>2</sup>				GRADING RULES AGENCY
		Bending		Compression Perpendicular to Grain $F_{c\perp}$	Modulus of Elasticity $E$	
		Single Member $F_b$	Repetitive Member $(F_c)(C_T)$			
<b>BALSAM FIR</b>						
Select	2" to 4" thick	—	1,650	—	1,500,000	NELMA
Commercial	4" to 12" wide	—	1,400	—	1,300,000	
<b>COAST SITKA SPRUCE</b>						
Select	2" to 4" thick	1,250	1,450	455	1,700,000	NLGA
Commercial	6" and wider	1,050	1,200	455	1,500,000	
<b>COAST SPECIES</b>						
Select	2" to 4" thick	1,250	1,450	370	1,500,000	NLGA
Commercial	6" and wider	1,050	1,200	370	1,400,000	
<b>DOUGLAS FIR-LARCH</b>						
Select dex	2" to 4" thick	1,750	2,000	625	1,800,000	WCLIB
Commercial dex	6" to 8" wide	1,450	1,650	625	1,700,000	
Select	2" to 4" thick	—	2,000	—	1,800,000	WWPA
Commercial	4" to 12" wide	—	1,650	—	1,700,000	
<b>DOUGLAS FIR-LARCH (North)</b>						
Select	2" to 4" thick	1,750	2,000	625	1,800,000	NLGA
Commercial	6" and wider	1,450	1,650	625	1,700,000	
<b>DOUGLAS FIR-SOUTH</b>						
Select	2" to 4" thick	—	1,900	—	1,400,000	WWPA
Commercial	4" to 12" wide	—	1,600	—	1,300,000	
<b>EASTERN HEMLOCK-TAMARACK</b>						
Select	2" to 4" thick	—	1,700	—	1,300,000	NELMA
Commercial	4" to 12" wide	—	1,450	—	1,100,000	
<b>EASTERN HEMLOCK-TAMARACK (North)</b>						
Select	2" to 4" thick	1,500	1,700	555	1,300,000	NLGA
Commercial	6" and wider	1,250	1,450	555	1,100,000	
<b>EASTERN SPRUCE</b>						
Select	2" to 4" thick	—	1,300	—	1,500,000	NELMA
Commercial	4" to 12" wide	—	1,100	—	1,400,000	

**1994 UNIFORM BUILDING CODE**

*(Continued)*

TABLE 23-1-A-5—DESIGN VALUES FOR VISUALLY GRADED DECKING—(Continued)

SPECIES AND COMMERCIAL GRADE	SIZE CLASSIFICATION × 25.4 for mm	DESIGN VALUES IN POUNDS PER SQUARE INCH (psi) × 0.00689 for N/mm <sup>2</sup>				GRADING RULES AGENCY
		Bending		Compression Perpendicular to Grain $F_{c\perp}$	Modulus of Elasticity $E$	
		Single Member $F_b$	Repetitive Member $(F_b)(C_r)$			
<b>EASTERN WHITE PINE</b>						
Select	2" to 4" thick	—	1,300	—	1,200,000	NELMA
Commercial	4" to 12" wide	—	1,100	—	1,100,000	
<b>EASTERN WHITE PINE (North)</b>						
Select	2" to 4" thick	900	1,050	350	1,200,000	NLGA
Commercial	6" and wider	775	875	350	1,100,000	
<b>HEM-FIR</b>						
Select dex	2" to 4" thick	1,400	1,600	405	1,500,000	WCLIB
Commercial dex	6" to 8" wide	1,150	1,350	405	1,400,000	
Select	2" to 4" thick	—	1,600	—	1,500,000	WWPA
Commercial	4" to 12" wide	—	1,350	—	1,400,000	
<b>HEM-FIR (North)</b>						
Select	2" to 4" thick	1,350	1,500	370	1,500,000	NLGA
Commercial	6" and wider	1,100	1,300	370	1,400,000	
<b>NORTHERN PINE</b>						
Select	2" to 4" thick	—	1,550	—	1,400,000	NELMA
Commercial	4" to 12" wide	—	1,300	—	1,300,000	
<b>NORTHERN SPECIES</b>						
Select	2" to 4" thick	900	1,050	350	1,100,000	NLGA
Commercial	6" and wider	775	875	350	1,000,000	
<b>NORTHERN WHITE CEDAR</b>						
Select	2" to 4" thick	—	1,100	—	800,000	NELMA
Commercial	4" to 12" wide	—	950	—	700,000	
<b>PONDEROSA PINE</b>						
Select	2" to 4" thick	1,200	1,450	535	1,300,000	NLGA
Commercial	6" and wider	1,000	1,250	535	1,100,000	
<b>RED PINE</b>						
Select	2" to 4" thick	1,150	1,350	440	1,300,000	NLGA
Commercial	6" and wider	975	1,100	440	1,200,000	

<b>REDWOOD</b>						
Select, close grain	2" thick	1,850	2,150	—	1,400,000	RIS
Select		1,450	1,700	—	1,100,000	
Commercial	6" and wider	1,200	1,350	—	1,000,000	
Deck heart and Deck common	2" thick 4" wide	400	450	420	900,000	RIS
	2" thick 6" wide	700	800	420	900,000	
<b>SITKA SPRUCE</b>						
Select dex	2" to 4" thick	1,300	1,500	435	1,500,000	WCLIB
Commercial dex	6" to 8" wide	1,100	1,250	435	1,300,000	
<b>SOUTHERN PINE</b>						
Dense standard	2" to 4" thick	2,000	2,300	660	1,800,000	SPIB
Dense select		1,650	1,900	660	1,600,000	
Select	2" and wider	1,400	1,650	565	1,600,000	
Dense commercial		1,650	1,900	660	1,600,000	
Commercial		1,400	1,650	565	1,600,000	
<b>SOUTHERN PINE</b>						
Dense standard	2 1/2" to 4" thick	1,600	1,800	440	1,600,000	SPIB
Dense select		1,350	1,500	440	1,400,000	
Select	2" and wider	1,150	1,300	375	1,400,000	
Dense commercial		1,350	1,500	440	1,400,000	
Commercial		1,150	1,300	375	1,400,000	
<b>SPRUCE-PINE-FIR</b>						
Select	2" to 4" thick	1,200	1,400	425	1,500,000	NLGA
Commercial	6" and wider	1,000	1,150	425	1,300,000	
<b>SPRUCE-PINE-FIR (South)</b>						
Select	2" to 4" thick	—	1,350	—	1,400,000	NELMA WWPA
Commercial	4" to 12" wide	—	1,100	—	1,200,000	
<b>WESTERN CEDARS</b>						
Select dex	2" to 4" thick	1,250	1,450	425	1,100,000	WCLIB
Commercial dex	6" to 8" wide	1,050	1,200	425	1,000,000	
Select	2" to 4" thick	—	1,450	—	1,100,000	WWPA
Commercial	4" to 12" wide	—	1,200	—	1,000,000	

(Continued)

TABLE 23-I-A-5—DESIGN VALUES FOR VISUALLY GRADED DECKING—(Continued)

SPECIES AND COMMERCIAL GRADE	SIZE CLASSIFICATION × 25.4 for mm	DESIGN VALUES IN POUNDS PER SQUARE INCH (psi) × 0.00689 for N/mm <sup>2</sup>				GRADING RULES AGENCY
		Bending		Compression Perpendicular to Grain $F_{c\perp}$	Modulus of Elasticity $E$	
		Single Member $F_b$	Repetitive Member $(F_c)(C_r)$			
<b>WESTERN CEDARS (North)</b>						
Select	2" to 4" thick	1,200	1,400	425	1,100,000	NLGA
Commercial	6" and wider	1,050	1,200	425	1,000,000	
<b>WESTERN HEMLOCK</b>						
Select dex	2" to 4" thick	1,500	1,750	410	1,600,000	WCLIB
Commercial dex	6" to 8" wide	1,300	1,450	410	1,400,000	
<b>WESTERN HEMLOCK (North)</b>						
Select	2" to 4" thick	1,500	1,750	410	1,600,000	NLGA
Commercial	6" and wider	1,300	1,450	410	1,400,000	
<b>WESTERN WHITE PINE</b>						
Select	2" to 4" thick	1,100	1,300	375	1,400,000	NLGA
Commercial	6" and wider	925	1,050	375	1,300,000	
<b>WESTERN WOODS</b>						
Selected	2" to 4" thick	—	1,300	—	1,200,000	WWPA

**Notes:**

- Lumber Dimensions.** Tabulated design values are applicable to lumber that will be used under dry conditions such as in most covered structures. For 2-inch- (51 mm) to 4-inch-thick (102 mm) lumber, the DRY dressed sizes shall be used regardless of the moisture content at the time of manufacture or use. In calculating design values, the natural gain in strength and stiffness that occurs as lumber dries has been taken into consideration as well as the reduction in size that occurs when unseasoned lumber shrinks. The gain in load-carrying capacity due to increased strength and stiffness resulting from drying more than offsets the design effect of size reductions due to shrinkage.
- Size Factor,  $C_F$ .** Bending design values for all species of decking except redwood are based on 4-inch-thick decking. When 2-inch-thick (51 mm) or 3-inch-thick (76 mm) decking is used, the bending design values,  $F_b$ , for all species except redwood shall be multiplied by the following size factors:

SIZE FACTORS,  $C_F$ 

Thickness (inches)	$C_F$
× 25.4 for mm	
2	1.10
3	1.04

- Flat-use Factor,  $C_{fu}$ .** Tabulated bending design values,  $F_b$ , for decking have already been adjusted for flatwise usage (load applied to wide face.)

4. **Repetitive Member Factor,  $C_r$ .** Tabulated bending design values for repetitive member uses ( $F_b$ ,  $C_r$ ) for decking have already been multiplied by the repetitive member factor,  $C_r$ .
5. **Wet Service Factor,  $C_M$ .** When decking is used where moisture content will exceed 19 percent for an extended time period, design values shall be multiplied by the appropriate wet service factors from the following table (for southern pine use tabulated design values for wet service conditions without further adjustment):

**WET SERVICE FACTORS,  $C_M$**

$F_b$	$F_{c\perp}$	$E$
0.85*	0.67	0.9

\*when  $(F_b)(C_F) \leq 1,150$  psi (7.92 N/mm<sup>2</sup>),  $C_M = 1.0$

**TABLE 23-I-A-6—APPLICABILITY OF ADJUSTMENT FACTORS**

	LOAD DURATION FACTOR	WET SERVICE FACTOR	TEMPERATURE FACTOR	SIZE FACTOR <sup>1</sup>	VOLUME FACTOR <sup>2</sup>	FLAT-USE FACTOR <sup>3</sup>	REPETITIVE MEMBER FACTOR <sup>4</sup>	CURVATURE FACTOR <sup>5</sup>	FORM FACTOR	SHEAR STRESS FACTOR <sup>6</sup>	BUCKLING STIFFNESS FACTOR <sup>7</sup>	BEARING AREA FACTOR
$F_b' = (F_b)$	( $C_D$ )	( $C_M$ )	( $C_t$ )	( $C_F$ )	( $C_V$ )	( $C_{fu}$ )	( $C_r$ )	( $C_c$ )	( $C_j$ )	•	•	•
$F_t' = (F_t)$	( $C_D$ )	( $C_M$ )	( $C_t$ )	( $C_F$ )	•	•	•	•	•	•	•	•
$F_v' = (F_v)$	( $C_D$ )	( $C_M$ )	( $C_t$ )	•	•	•	•	•	•	( $C_H$ )	•	•
$F_{c\perp}' = (F_{c\perp})$	•	( $C_M$ )	( $C_t$ )	•	•	•	•	•	•	•	•	( $C_b$ )
$F_c' = (F_c)$	( $C_D$ )	( $C_M$ )	( $C_t$ )	( $C_F$ )	•	•	•	•	•	•	•	•
$E' = (E)$	•	( $C_M$ )	( $C_t$ )	•	•	•	•	•	•	•	( $C_T$ )	•
$F_g' = (F_g)$	( $C_D$ )	•	( $C_t$ )	•	•	•	•	•	•	•	•	•

<sup>1</sup>The size factor,  $C_F$ , shall apply only to visually graded sawn lumber members and to round timber bending members.

<sup>2</sup>The volume factor,  $C_V$ , shall apply only to glued-laminated timber bending members.

<sup>3</sup>The flat-use factor,  $C_{fu}$ , shall apply only to dimension lumber bending members 2 inches (51 mm) to 4 inches (102 mm) thick and to glued-laminated timber bending members.

<sup>4</sup>The repetitive member factor,  $C_r$ , shall apply only to dimension lumber bending members 2 inches (51 mm) to 4 inches (102 mm) thick.

<sup>5</sup>The curvature factor,  $C_c$ , shall apply only to curved portions of glued-laminated timber bending members.

<sup>6</sup>Shear design values parallel to grain,  $F_v$ , for sawn lumber members shall be permitted to be multiplied by the shear stress factors,  $C_H$ .

<sup>7</sup>The buckling stiffness factor,  $C_T$ , shall apply only to 2-inch (51 mm) by 4-inch (102 mm) or smaller sawn lumber truss compression chords subjected to combined flexure and axial compression when <sup>3</sup>/<sub>8</sub>-inch (9.5 mm) or thicker plywood sheathing is nailed to the narrow face.

**TABLE 23-I-B—ALLOWABLE UNIT STRESSES FOR CONSTRUCTION AND INDUSTRIAL SOFTWOOD PLYWOOD**  
 (In pounds per square inch—normal loading)  
 (To be used with section properties in Plywood-design Specifications—See U.B.C. Standard 23-2)

STRESS	SPECIES <sup>1</sup> GROUP OF FACE PLY	EXTERIOR A-A, A-C, C-C		EXTERIOR A-B, B-B, B-C C-C (PLUGGED)		ALL OTHER GRADES OF INTERIOR INCLUDING C-D SHEATHING
		Structural I A-C, C-C (Use Group I Stresses)		Structural I C-D (Use Group 1 Stresses)		
		Wet <sup>2</sup>		Wet <sup>2</sup>		
		Dry <sup>3</sup>		Dry <sup>3</sup>		
		× 0.00689 for N/mm <sup>2</sup>				
1. Extreme fiber stress in bending ( $F_b$ )	1	1,430	2,000	1,190	1,650	1,650
Tension in plane of plies ( $F_t$ )	2, 3	980	1,400	820	1,200	1,200
Face grain parallel or perpendicular to span (at 45° to face grain use $1/6 F_t$ )	4	940	1,330	780	1,110	1,110
2. Compression in plane of plies ( $F_c$ )	1	970	1,640	900	1,540	1,540
Parallel or perpendicular to face grain	2	730	1,200	680	1,100	1,100
(at 45° to face grain use $1/3 F_c$ )	3	610	1,060	580	990	990
	4	610	1,000	580	950	950
3. Shear in plane perpendicular to plies $F_v$ <sup>4</sup>	1	155	190	155	190	160
Parallel or perpendicular to face grain (at 45° to face grain use 2 $F_v$ )	2, 3	120	140	120	140	120
	4	110	130	110	130	115
4. Shear, rolling, in the plane of plies	Marine and Structural I	63	75	63	75	
Parallel or perpendicular to face grain (at 45° to face grain use $1/3 F_s$ )	Structural II	49	56	49	56	
	All others <sup>5</sup>	44	53	44	53	48
5. Bearing (on face)	1	210	340	210	340	340
Perpendicular to plane of plies	2, 3	135	210	135	210	210
	4	105	160	105	160	160
6. Modulus of elasticity	1	1,500,000	1,800,000	1,500,000	1,800,000	1,800,000
In bending in plane of plies	2	1,300,000	1,500,000	1,300,000	1,500,000	1,500,000
Face grain parallel or perpendicular to span	3	1,100,000	1,200,000	1,100,000	1,200,000	1,200,000
	4	900,000	1,000,000	900,000	1,000,000	1,000,000

**SPAN RATING**

THICKNESS (inches)	C-C AND C-D							UNDERLAYMENT AND C-C PLUGGED			
	12/0	16/0	20/0	24/0	32/16	40/20	48/24	16" o.c.	20" o.c.	24" o.c.	48" o.c.
× 25.4 for mm								× 25.4 for mm			
$\frac{5}{16}$	4	3	1								
$\frac{3}{8}$			4 <sup>7</sup>	1							
$\frac{15}{32}$ <sup>6</sup> , $\frac{1}{2}$				4 <sup>7</sup>	1			1			
$\frac{19}{32}$ , $\frac{5}{8}$					4 <sup>7</sup>	1		4 <sup>7</sup>	1		
$\frac{23}{32}$ , $\frac{3}{4}$						4 <sup>7</sup>	1		4 <sup>7</sup>	1	
$\frac{7}{8}$							3 <sup>8</sup>			3 <sup>8</sup>	
$1\frac{1}{8}$											1

<sup>1</sup>See U.B.C. Standard 23-2 for plywood species groups. For C-C, C-D underlayment, and C-C plugged, the combination of span rating and panel thickness determines the species group and, therefore, the stress permitted, as in the above table.

<sup>2</sup>Wet condition of use corresponds to a moisture content of 16 percent or more.

<sup>3</sup>Dry condition of use corresponds to a moisture content of less than 16 percent.

<sup>4</sup>See U.B.C. Standard 23-2, Section 23.221, for provisions under which  $F_v$  stresses may be increased.

<sup>5</sup>Reduce stresses 25 percent for three-layer (four-ply) panels over  $\frac{5}{8}$  inch (16 mm) thick.

<sup>6</sup>Thickness not applicable to underlayment and C-C plugged.

<sup>7</sup>Use Group 3 stresses for structural II.

<sup>8</sup>Use Group 4 stresses for underlayment and C-C plugged 24 inches (610 mm) on center.

**TABLE 23-I-C-1, PART A—ALLOWABLE UNIT STRESSES FOR STRUCTURAL GLUED-LAMINATED  
TIMBER FOR NORMAL LOADING DURATION<sup>1,2,3</sup>**  
Members stressed principally in bending with load applied perpendicular to the wide faces of the laminations

COMBINATION SY M-BOL <sup>4</sup>	SPECIES OUTER LAMINATIONS/ CORE LAMINATIONS <sup>5</sup>	BENDING ABOUT X-X AXIS						BENDING ABOUT Y-Y AXIS					AXIALLY LOADED		
		Loaded Perpendicular to Wide Faces of Laminations		Loaded Parallel to Wide Faces of Laminations											
		Extreme Fiber in Bending $F_{bxx}$		Compression Perpendicular to Grain $F_c \perp xx$ <sup>6</sup>		Horizontal Shear $F_{vxx}$ psi	Modulus of Elasticity $E_{xx}$ <sup>6</sup> x 10 <sup>6</sup> psi	Extreme Fiber in Bendings <sup>7,10</sup> $F_{byy}$ psi	Compression Perpendicular to Grain $F_c \perp yy$ <sup>6</sup> psi	Horizontal Shear $F_{vyx}$ psi	Horizontal Shear $F_{yyy}$ psi (For members with multiple-piece laminations which are not edge glued) <sup>11</sup>	Modulus of Elasticity $E_{yy}$ <sup>6</sup> x 10 <sup>6</sup> psi	Tension Parallel to Grain $f_t$ psi	Compression Parallel to Grain $F_c$ psi	Modulus of Elasticity $E^6$ x 10 <sup>6</sup> psi
		Tension Zone Stressed in Tension <sup>7,8</sup> psi	Compression Zone Stressed in Tension <sup>9</sup> psi	Tension Face psi	Compression Face psi										
× 0.00689 for N/mm <sup>2</sup>															
1	2	3	4	5	6	7	8	9	10	11	12	13	14	15	16
<b>Visually Graded Western Species</b>															
The following four combinations are not balanced and are for either dry or wet use.															
16F-V1	DF/WW	1,600	800	560 <sup>12,13</sup>	560 <sup>12,13</sup>	140 <sup>14,15</sup>	1.3	950	255	130	65	1.1	675	975	1.1
16F-V2	HF/HF			500 <sup>16</sup>	375 <sup>16</sup>	155	1.4	1,250	375	135	70	1.3	875	1,300	1.3
16F-V3	DF/DF			560 <sup>12,13</sup>	560	165	1.5	1,450	560	145	75	1.5	950	1,550	1.5
16F-V8	DFS/DFS			650	500	165	1.2	1,200	500	145	75	1.1	825	1,350	1.1
The following two combinations are intended for straight or slightly cambered members for dry use and industrial appearance. <sup>17</sup>															
16F-V4	DF/N3WW	1,600	800	650	560 <sup>12</sup>	90 <sup>13,16</sup>	1.5 <sup>18</sup>	900	255	130	65	1.3 <sup>18</sup>	650	600	1.3
16F-V5	DF/M3DF			650	560 <sup>12</sup>	90 <sup>19</sup>	1.6	1,000	470	135	70	1.5	750	875	1.5
The following two combinations are balanced and are intended for members continuous or cantilevered over supports and provide equal capacity in both positive and negative bending.															
16F-V6	DF/DF	1,600	1,600	560 <sup>12,13</sup>	560 <sup>12</sup>	165	1.5	1,450	560	145	75	1.4	950	1,550	1.5
16F-V7	HF/HF			375 <sup>16</sup>	375 <sup>16</sup>	155	1.4	1,200	375	135	70	1.3	850	1,350	1.3
The following seven combinations are not balanced and are for either dry or wet use.															
20F-V1	DF/WW	2,000	1,000	650	560 <sup>12</sup>	140 <sup>14,15</sup>	1.4 <sup>18</sup>	1,000	255	130	65	1.2 <sup>18</sup>	750	1,000	1.2
20F-V2	HF/HF			500 <sup>16</sup>	375 <sup>16</sup>	155	1.5	1,200	375	135	70	1.4	950	1,350	1.4
20F-V3	DF/DF			650	560 <sup>12</sup>	165	1.6	1,450	560	145	75	1.5	1,000	1,550	1.5
20F-V4	DF/DF			590 <sup>12,13</sup>	560 <sup>12</sup>	165	1.6	1,450	560	145	75	1.6	1,000	1,550	1.6
20F-V10	DF/HF			650	560	155	1.5	1,300	375	135	70	1.4	950	1,500	1.4
20F-V11	DFS/DFS			650	500	165	1.3	1,400	500	145	75	1.1	900	1,400	1.1
20F-V12	AC/AC			560	560	190	1.5	1,200	470	165	80	1.4	900	1,500	1.4

The following two combinations are intended for straight or slightly cambered members for dry use and industrial appearance. <sup>17</sup>															
20F-V5	DF/N3WW	2,000	1,000	650	560 <sup>12</sup>	90 <sup>14,20</sup>	1.6	1,000	255	135	70	1.3	750	725	1.3
20F-V6	DF/M3DF			650	560 <sup>12</sup>	90 <sup>19</sup>	1.6	1,000	470	135	70	1.5	775	900	1.5
The following three combinations are balanced and are intended for members continuous or cantilevered over supports and provide equal capacity in both positive and negative bending.															
20F-V7	DF/DF	2,000	2,000	650	650	165	1.6	1,450	560	145	75	1.6	1,000	1,600	1.6
20F-V8	DF/DF			590 <sup>12,13</sup>	590 <sup>12,13</sup>	165	1.7	1,450	560	145	75	1.6	1,000	1,600	1.6
20F-V9	HF/HF			500 <sup>16</sup>	500 <sup>16</sup>	155	1.5	1,400	375	135	70	1.4	975	1,400	1.4
The following five combinations are not balanced and are for either dry or wet use.															
22F-V1	DF/WW	2,200	1,100	650	560 <sup>12</sup>	140 <sup>14</sup>	1.6 <sup>18</sup>	1,050	255	130	65	1.3 <sup>18</sup>	850	1,100	1.3
22F-V2	HF/HF			500 <sup>16</sup>	500 <sup>16</sup>	155	1.5	1,250	375	135	70	1.4	950	1,350	1.4
22F-V3	DF/DF			650	560 <sup>16</sup>	165	1.7	1,450	560	145	75	1.6	1,050	1,500	1.6
22F-V4	DF/DF			590 <sup>12,13</sup>	560 <sup>12</sup>	165	1.7	1,450	560	145	75	1.6	1,000	1,550	1.6
22F-V10	DF/DFS			650	560 <sup>12</sup>	165	1.6	1,600	500	145	75	1.3	1,000	1,400	1.3
The following two combinations are intended for straight or slightly cambered members for dry use and industrial appearance. <sup>17</sup>															
22F-V5	DF/3WW	2,200	1,100	650	560 <sup>12</sup>	90 <sup>14,20</sup>	1.6 <sup>18</sup>	1,100	255	135	75	1.4 <sup>18</sup>	800	725	1.4
22F-V6	DF/M3DF			650	560 <sup>12</sup>	90 <sup>19</sup>	1.7	1,250	470	135	75	1.6	900	925	1.6
The following three combinations are balanced and are intended for members continuous or cantilevered over supports and provide equal capacity in both positive and negative bending.															
22F-V7	DF/DF	2,200	2,200	650	650	165	1.8	1,450	560	145	75	1.6	1,100	1,650	1.6
22F-V8	DF/DF			590 <sup>12,13</sup>	590 <sup>12,13</sup>	165	1.7	1,450	560	145	75	1.6	1,050	1,650	1.6
22F-V9	HF/HF			500 <sup>16</sup>	500 <sup>16</sup>	155	1.5	1,250	375	135	70	1.4	975	1,400	1.4
The following six combinations are not balanced and are for either dry or wet use.															
24F-V1	DF/WW	2,400	1,200	650	650	140 <sup>15</sup>	1.7 <sup>18</sup>	1,250	255	130	70	1.4 <sup>18</sup>	1,000	1,300	1.4
24F-V2	HF/HF			500 <sup>16</sup>	500 <sup>16</sup>	155	1.5	1,250	375	135	70	1.4	950	1,300	1.4
24F-V3	DF/DF			650	560 <sup>12</sup>	165	1.8	1,500	560	145	75	1.6	1,100	1,600	1.6
24F-V4	DF/DF			650	650	165	1.8	1,500	560	145	75	1.6	1,150	1,650	1.6
24F-V5	DF/HF			650	650	155	1.7	1,350	375	140	70	1.5	1,100	1,450	1.5
24F-V11	DF/DFS			650	560 <sup>12</sup>	165	1.7	1,600	500	145	75	1.4	1,150	1,700	1.4
The following two combinations are intended for straight or slightly cambered members for dry use and industrial appearance. <sup>17</sup>															
24F-V6	DF/N3WW	2,400	1,200	650	560 <sup>12</sup>	90 <sup>2,3,14,20</sup>	1.7 <sup>18</sup>	1,200	255	140	70	1.5 <sup>18</sup>	950	800	1.5
24F-V7	DF/M3DF			650	560 <sup>12</sup>	90 <sup>19</sup>	1.7	1,250	470	135	70	1.6	900	950	1.6
The following three combinations are balanced and are intended for members continuous or cantilevered over supports and provide equal capacity in both positive and negative bending.															
24F-V8	DF/DF	2,400	2,400	650	650	165	1.8	1,450	560	145	75	1.6	1,100	1,650	1.6
24F-V9	HF/HF			500 <sup>16</sup>	500 <sup>16</sup>	155	1.5	1,500	375	135	70	1.4	1,000	1,450	1.4
24F-V10	DF/HF			650	650	155	1.8	1,400	375	140	70	1.6	1,150	1,600	1.6
Wet-use factors <sup>2</sup>		0.8	0.8	0.667	0.667	0.875	0.833	0.8	0.667	0.875	0.875	0.833	0.8	0.73	0.833

(Continued)

TABLE 23-I-C-1, PART A—ALLOWABLE UNIT STRESSES FOR STRUCTURAL GLUED-LAMINATED TIMBER FOR NORMAL LOADING DURATION<sup>1,2,3</sup>—(Continued)

COMBI-NATION SY M-BOL <sup>4</sup>	SPECIES OUTER LAMINA-TIONS/ CORE LAMINA-TIONS <sup>5</sup>	BENDING ABOUT X-X AXIS						BENDING ABOUT Y-Y AXIS					AXIALLY LOADED		
		Loaded Perpendicular to Wide Faces of Laminations		Loaded Parallel to Wide Faces of Laminations											
		Extreme Fiber in Bending $F_{bxx}$		Compression Perpendicular to Grain $F_{c \perp xx}$ <sup>6</sup>		Horizontal Shear $F_{vxx}$ psi	Modulus of Elasticity $E_{xx}$ <sup>6</sup> x $10^6$ psi	Extreme Fiber in Bend-ings <sup>7,10</sup> $F_{byy}$ psi	Compression Per-pendicular to Grain $F_{c \perp yy}$ <sup>6</sup> psi	Horizontal Shear $F_{vyx}$ psi	Horizontal Shear $F_{yy}$ psi (For members with multiple-piece laminations which are not edge glued) <sup>11</sup>	Modulus of Elasticity $E_{yy}$ <sup>6</sup> x $10^6$ psi	Tension Parallel to Grain $F_t$ psi	Compression Parallel to Grain $F_c$ psi	Modulus of Elasticity $E^6$ x $10^6$ psi
		Tension Zone Stressed in Tension <sup>7,8</sup> psi	Compression Zone Stressed in Tension <sup>8</sup> psi	Tension Face psi	Compression Face psi										
× 0.00689 for N/mm <sup>2</sup>															
1	2	3	4	5	6	7	8	9	10	11	12	13	14	15	16
<b>E-Rated Western Species</b>															
The following three combinations are not balanced and are for either dry or wet use.															
16F-E1	WW/WW	1,600	800	255 <sup>21</sup>	255 <sup>21</sup>	140 <sup>14,15</sup>	1.3 <sup>18</sup>	1,050	255	125	65	1.2 <sup>18</sup>	725	925	1.2
16F-E2 <sup>22</sup>	HF/HF			500 <sup>23</sup>	500 <sup>23</sup>	155	1.4	1,250	375	135	70	1.3	825	1,200	1.3
16F-E3	DF/DF			650	650	165	1.6	1,450	560	145	75	1.5	975	1,600	1.5
The following two combinations are intended for straight or slightly cambered members for dry use and industrial appearance. <sup>17</sup>															
16F-E4	DF/N3WW	1,600	800	650	650	90 <sup>2,3,14,20</sup>	1.6 <sup>18</sup>	900	255	130	65	1.3 <sup>18</sup>	675	675	1.3
16F-E5	DF/M3DF			650	650	90 <sup>19</sup>	1.6	1,050	470	135	70	1.5	700	900	1.5
The following two combinations are balanced and are intended for members continuous or cantilevered over supports and provide equal capacity in both positive and negative bending.															
16F-E6	DF/DF	1,600	1,600	650	650	165	1.6	1,500	560	145	75	1.5	1,000	1,600	1.5
16F-E7 <sup>22</sup>	HF/HF			500 <sup>23</sup>	500 <sup>23</sup>	155	1.4	1,250	375	135	70	1.3	850	1,150	1.3
The following four combinations are not balanced and are for either dry or wet use.															
20F-E1	WW/WW	2,000	1,000	255 <sup>21</sup>	255 <sup>22</sup>	140 <sup>14,15</sup>	1.6 <sup>18</sup>	1,100	255	125	65	1.3 <sup>18</sup>	800	1,050	1.3
20F-E2 <sup>22</sup>	HF/HF			500 <sup>23</sup>	500 <sup>23</sup>	155	1.6	1,400	375	135	70	1.4	925	1,550	1.4
20F-E3	DF/DF			650	650	165	1.7	1,550	560	145	75	1.6	1,050	1,650	1.6
20F-E8	ES/ES			450	450	145	1.5	1,400	300	125	65	1.4	800	1,000	1.4
The following two combinations are intended for straight or slightly cambered members for dry use and industrial appearance. <sup>17</sup>															
20F-E4	DF/N3WW	2,000	1,000	650	650	90 <sup>2,3,14,20</sup>	1.6 <sup>18</sup>	1,100	255	130	65	1.4 <sup>18</sup>	800	700	1.4
20F-E5	DF/M3DF			650	650	90 <sup>19</sup>	1.7	1,300	470	135	70	1.6	825	975	1.6

<b>The following two combinations are balanced and are intended for members continuous or cantilevered over supports and provide equal capacity in both positive and negative bending.</b>															
20F-E6	DF/DF	2,000	2,000	650	650	165	1.7	1,600	560	145	75	1.6	1,150	1,650	1.6
20F-E7 <sup>22</sup>	HF/HF			500 <sup>23</sup>	500 <sup>23</sup>	155	1.6	1,500	375	135	70	1.4	1,050	1,550	1.4
<b>The following two combinations are not balanced and are for either dry or wet use.</b>															
22F-E1	DF/DF	2,200	1,100	650	650	165	1.7	1,550	560	145	75	1.6	1,050	1,600	1.6
22F-E2 <sup>22</sup>	HF/HF			500 <sup>23</sup>	500 <sup>23</sup>	155	1.6	1,400	375	135	70	1.4	950	1,400	1.4
<b>The following two combinations are intended for straight or slightly cambered members for dry use and industrial appearance.<sup>20</sup></b>															
22F-E3	DF/N3WW	2,200	1,100	650	650	90 <sup>2,3,14,20</sup>	1.7 <sup>18</sup>	1,250	255	135	70	1.4 <sup>18</sup>	825	750	1.4
22F-E4	DF/N3DF			650	650	90 <sup>19</sup>	1.8	1,350	470	135	70	1.6	950	950	1.6
<b>The following two combinations are balanced and are intended for members continuous or cantilevered over supports and provide equal capacity in both positive and negative bending.</b>															
22F-E5	DF/DF	2,200	2,200	650	650	165	1.7	1,650	560	145	75	1.6	1,100	1,650	1.6
22F-E6 <sup>22</sup>	HF/HF			500 <sup>23</sup>	500 <sup>23</sup>	155	1.7	1,550	375	135	70	1.5	1,050	1,500	1.5
<b>The following six combinations are not balanced and are for either dry or wet use.</b>															
24F-E1	DF/DF	2,400	1,200	650	650	165	1.8	1,550	560	145	75	1.6	1,100	1,600	1.6
24F-E2 <sup>22</sup>	HF/HF			500 <sup>23</sup>	500 <sup>23</sup>	155	1.7	1,300	375	135	70	1.5	850	1,400	1.5
24F-E3	DF/HF			650	500 <sup>23</sup>	155	1.8	1,500	375	135	70	1.5	1,050	1,550	1.5
24F-E4	DF/DF			650	650	165	1.8	1,650	560	145	75	1.7	1,100	1,700	1.7
24F-E5	DF/DF			650	650	165	1.8	1,650	560	145	75	1.6	1,100	1,550	1.6
24F-E6 <sup>22</sup>	HF/WW			500 <sup>23</sup>	500 <sup>23</sup>	140 <sup>14,15</sup>	1.8 <sup>18</sup>	1,100	255	130	65	1.4 <sup>18</sup>	750	1,250	1.4
<b>The following five combinations are intended for straight or slightly cambered members for dry use and industrial appearance.<sup>17</sup></b>															
24F-E14	DF/DF	2,400	1,200	650	650	165	1.8	1,450	560	145	75	1.6	950	1,600	1.6
24F-E15	HF/HF			500 <sup>23</sup>	500 <sup>23</sup>	155	1.8	1,300	375	135	70	1.5	950	1,200	1.5
24F-E7	DF/N3WW			650	650	90 <sup>2,3,14,20</sup>	1.9 <sup>18</sup>	1,400	255	135	70	1.6 <sup>18</sup>	975	875	1.6
24F-E8	DF/N3DF			650	650	90 <sup>19</sup>	1.9	1,400	470	135	70	1.7	1,000	1,050	1.7
24F-E9 <sup>22</sup>	HF/N3HF			500 <sup>23</sup>	500 <sup>23</sup>	90 <sup>20</sup>	1.8	1,350	375	135	70	1.6	950	825	1.6
<b>The following eight combinations are balanced and are intended for members continuous or cantilevered over supports and provide equal capacity in both positive and negative bending.</b>															
24F-E10	DF/DF	2,400	2,400	650	650	165	1.9	1,850	560	145	75	1.7	1,300	1,750	1.7
24F-E11 <sup>22</sup>	HF/HF			500 <sup>23</sup>	500 <sup>23</sup>	155	1.8	1,600	375	135	70	1.5	1,150	1,550	1.5
24F-E12	DF/HF			650	650	155	1.9	1,750	375	135	70	1.6	1,200	1,600	1.6
24F-E13	DF/DF			650	650	165	1.8	1,950	560	145	75	1.7	1,250	1,700	1.7
24F-E16	HF/HF			500 <sup>23</sup>	500 <sup>23</sup>	155	1.7	1,300	375	135	70	1.5	850	1,400	1.5
24F-E17	HF/WW			500 <sup>23</sup>	500 <sup>23</sup>	140 <sup>14,15</sup>	1.8 <sup>18</sup>	1,100	255	130 <sup>14</sup>	65 <sup>14</sup>	1.4 <sup>18</sup>	750	1,250	1.4
24F-E18	DF/DF			650	650	165	1.8	1,450	560	145	75	1.6	950	1,600	1.6
24F-E19	HF/HF			500 <sup>23</sup>	500 <sup>23</sup>	155	1.8	1,300	375	135	70	1.5	950	1,200	1.5
Wet-use factors <sup>2</sup>		0.8	0.8	0.667	0.667	0.875	0.833	0.8	0.667	0.875	0.875	0.833	0.8	0.73	0.833

(Continued)

**TABLE 23-I-C-1, PART A—ALLOWABLE UNIT STRESSES FOR STRUCTURAL GLUED-LAMINATED TIMBER FOR NORMAL LOADING DURATION<sup>1,2,3</sup>—(Continued)**

COMBINATION SYM-BOL <sup>4</sup>	SPECIES OUTER LAMINATIONS/CORE LAMINATIONS <sup>5</sup>	BENDING ABOUT X-X AXIS						BENDING ABOUT Y-Y AXIS						AXIALLY LOADED	
		Loaded Perpendicular to Wide Faces of Laminations		Loaded Parallel to Wide Faces of Laminations											
		Extreme Fiber in Bending $F_{bx}$		Compression Perpendicular to Grain $F_c \perp x$ <sup>6</sup>		Horizontal Shear $F_{vx}$ psi	Modulus of Elasticity $E_{xx}$ <sup>6</sup> x $10^6$ psi	Extreme Fiber in Bending <sup>7,10</sup> $F_{by}$ psi	Compression Perpendicular to Grain $F_c \perp y$ <sup>6</sup> psi	Horizontal Shear $F_{vy}$ psi	Horizontal Shear $F_{yy}$ psi (For members with multiple-piece laminations which are not edge glued) <sup>11</sup>	Modulus of Elasticity $E_{yy}$ <sup>6</sup> x $10^6$ psi	Tension Parallel to Grain $F_t$ psi	Compression Parallel to Grain $F_c$ psi	Modulus of Elasticity $E^6$ x $10^6$ psi
		Tension Zone Stressed in Tension <sup>7,8</sup> psi	Compression Zone Stressed in Tension <sup>9</sup> psi	Tension Face psi	Compression Face psi										
× 0.00689 for N/mm <sup>2</sup>															
1	2	3	4	5	6	7	8	9	10	11	12	13	14	15	16
<b>Visually Graded Southern Pine</b>															
16F-V1	SP/SP	1,600	800	560 <sup>12,13</sup>	560 <sup>12</sup>	200	1.4	1,450	560	175	90	1.3	950	1,450	1.3
16F-V2	SP/SP			500 <sup>12,13</sup>	500 <sup>12</sup>	200	1.4	1,600	560	175	90	1.4	1,000	1,550	1.4
16F-V3	SP/SP			650	650	200	1.4	1,450	560	175	90	1.3	975	1,450	1.3
The following combination is intended for straight or slightly cambered members for dry use and industrial appearance. <sup>17</sup>															
16F-V4	SP/SP	1,600	800	560 <sup>12,13</sup>	560 <sup>12</sup>	90 <sup>24</sup>	1.3	975	470	150	75	1.2	650	950	1.2
The following combination is balanced and intended for members continuous or cantilevered over supports and provides equal capacity in both positive and negative bending.															
16F-V5	SP/SP	1,600	1,600	560 <sup>12,13</sup>	560 <sup>12,13</sup>	200	1.4	1,600	560	175	85	1.4	1,000	1,550	1.4
The following three combinations are not balanced and are for either dry or wet use.															
20F-V1	SP/SP	2,000	1,000	650	560 <sup>12</sup>	200	1.5	1,450	560	175	85	1.4	1,000	1,450	1.4
20F-V2	SP/SP			650	560 <sup>12</sup>	200	1.6	1,450	560	175	85	1.4	1,050	1,550	1.4
20F-V3	SP/SP			560 <sup>12,13</sup>	560 <sup>12</sup>	200	1.4	1,600	560	175	85	1.4	1,000	1,500	1.4
The following combination is intended for straight or slightly cambered members for dry use and industrial appearance. <sup>17</sup>															
20F-V4	SP/SP	2,000	1,000	650	560 <sup>12</sup>	90 <sup>24</sup>	1.5	1,100	470	150	75	1.3	725	950	1.3
The following combination is balanced and intended for members continuous or cantilevered over supports and provides equal capacity in both positive and negative bending.															
20F-V5	SP/SP	2,000	2,000	650	560	200	1.6	1,450	650	175	85	1.4	1,050	1,550	1.4
The following three combinations are not balanced and are for either dry or wet use.															
22F-V1	SP/SP	2,200	1,100	650	650	200	1.6	1,600	560	175	85	1.5	1,050	1,650	1.5
22F-V2	SP/SP			560 <sup>12,13</sup>	560 <sup>12</sup>	200	1.4	1,600	560	175	85	1.4	1,000	1,500	1.4
22F-V3	SP/SP			650	560 <sup>12</sup>	200	1.6	1,500	560	175	85	1.4	1,050	1,500	1.4

<b>The following combination is intended for straight or slightly cambered members for dry use and industrial appearance.<sup>17</sup></b>															
22F-V4	SP/SP	2,200	1,100	650	560 <sup>12</sup>	90 <sup>24</sup>	1.6	1,250	470	155	75	1.4	825	1,000	1.4
<b>The following combination is balanced and intended for members continuous or cantilevered over supports and provides equal capacity in both positive and negative bending.</b>															
22F-V5	SP/SP	2,200	2,200	650	650	200	1.6	1,600	560	175	85	1.5	1,050	1,600	1.5
<b>The following four combinations are not balanced and are for either dry or wet use.</b>															
24F-V1	SP/SP	2,400	1,200	650	560 <sup>12</sup>	200	1.7	1,500	560	175	85	1.5	1,100	1,350	1.5
24F-V2	SP/SP			650	650	200	1.7	1,600	560	175	85	1.5	1,100	1,600	1.5
24F-V3	SP/SP			650	650	200	1.8	1,600	560	175	85	1.6	1,150	1,700	1.6
24F-V6	SP/SP			650	650	200	1.7	1,500	560	175	90	1.5	1,150	1,750	1.5
<b>The following combination is intended for straight or slightly cambered members for dry use and industrial appearance.<sup>17</sup></b>															
24F-V4	SP/SP	2,400	1,200	650	560 <sup>12</sup>	90 <sup>24</sup>	1.7	1,250	470	155	75	1.4	850	1,050	1.4
<b>The following combination is balanced and intended for members continuous or cantilevered over supports and provides equal capacity in both positive and negative bending.</b>															
24F-V5	SP/SP	2,400	2,400	650	650	200	1.7	1,600	560	175	90	1.5	1,150	1,700	1.5
Wet-use factors <sup>2</sup>		0.8	0.8	0.667	0.667	0.875	0.833	0.8	0.667	0.875	0.875	0.833	0.8	0.73	0.833
<b>E-Rated Southern Pine</b>															
<b>The following combination is not balanced and is for either dry or wet use.</b>															
16F-E1	SP/SP	1,600	800	650	650	200	1.6	1,550	560	175	90	1.5	1,050	1,600	1.5
<b>The following combination is intended for straight or slightly cambered members for dry use and industrial appearance.<sup>17</sup></b>															
16F-E2	SP/SP	1,600	800	650	650	90 <sup>24</sup>	1.6	950	470	145	75	1.3	700	1,050	1.3
<b>The following combination is balanced and intended for members continuous or cantilevered over supports and provides equal capacity in both positive and negative bending.</b>															
16F-E3	SP/SP	1,600	1,600	650	650	200	1.6	1,700	560	175	90	1.5	1,100	1,650	1.5
<b>The following combination is not balanced and is for either dry or wet use.</b>															
20F-E1	SP/SP	2,000	1,000	650	650	200	1.7	1,600	560	175	90	1.5	1,050	1,600	1.5
<b>The following combination is intended for straight or slightly cambered members for dry use and industrial appearance.<sup>17</sup></b>															
20F-E2	SP/SP	2,000	1,000	650	650	90 <sup>24</sup>	1.6	1,100	470	150	75	1.4	750	1,000	1.4
<b>The following combination is balanced and intended for members continuous or cantilevered over supports and provides equal capacity in both positive and negative bending.</b>															
20F-E3	SP/SP	2,000	2,000	650	650	200	1.7	1,800	560	175	90	1.5	1,150	1,700	1.5
<b>The following combination is not balanced and is for either dry or wet use.</b>															
22F-E1	SP/SP	2,200	1,100	650	650	200	1.7	1,600	560	175	90	1.5	1,050	1,650	1.5
<b>The following combination is intended for straight or slightly cambered members for dry use and industrial appearance.<sup>17</sup></b>															
22F-E2	SP/SP	2,200	1,100	650	650	90 <sup>24</sup>	1.6	1,250	470	155	80	1.4	850	1,050	1.4
<b>The following combination is balanced and intended for members continuous or cantilevered over supports and provides equal capacity in both positive and negative bending.</b>															
22F-E3	SP/SP	2,200	2,200	650	650	200	1.7	1,750	560	175	90	1.5	1,150	1,650	1.5
<b>The following two combinations are not balanced and are for either dry or wet use.</b>															
24F-E1	SP/SP	2,400	1,200	650	650	200	1.8	1,600	560	175	90	1.6	1,100	1,750	1.6
24F-E2	SP/SP			650	650	200	1.9	1,700	560	175	90	1.6	1,150	1,700	1.6

(Continued)

**TABLE 23-I-C-1, PART A—ALLOWABLE UNIT STRESSES FOR STRUCTURAL GLUED-LAMINATED TIMBER FOR NORMAL LOADING DURATION<sup>1,2,3</sup>—(Continued)**

COMBINATION SYM-BOL <sup>4</sup>	SPECIES OUTER LAMINATIONS/CORE LAMINATIONS <sup>5</sup>	BENDING ABOUT X-X AXIS						BENDING ABOUT Y-Y AXIS					AXIALLY LOADED		
		Loaded Perpendicular to Wide Faces of Laminations						Loaded Parallel to Wide Faces of Laminations							
		Extreme Fiber in Bending $F_{bx}$		Compression Perpendicular to Grain $F_{c \perp xx}$ <sup>6</sup>		Horizontal Shear $F_{vxx}$ psi	Modulus of Elasticity $E_{xx}$ <sup>6</sup> x $10^6$ psi	Extreme Fiber in Bendings <sup>7,10</sup> $F_{byy}$ psi	Compression Perpendicular to Grain $F_{c \perp yy}$ <sup>6</sup> psi	Horizontal Shear $F_{vy}$ psi	Horizontal Shear $F_{vy}$ psi (For members with multiple-piece laminations which are not edge glued) <sup>11</sup>	Modulus of Elasticity $E_{yy}$ <sup>6</sup> x $10^6$ psi	Tension Parallel to Grain $F_t$ psi	Compression Parallel to Grain $F_c$ psi	Modulus of Elasticity $E$ <sup>6</sup> x $10^6$ psi
		Tension Zone Stressed in Tension <sup>7,8</sup> psi	Compression Zone Stressed in Tension <sup>9</sup> psi	Tension Face psi	Compression Face psi										
× 0.00689 for N/mm <sup>2</sup>															
1	2	3	4	5	6	7	8	9	10	11	12	13	14	15	16
<b>E-Rated Southern Pine—(Continued)</b>															
The following combination is intended for straight or slightly cambered members for dry use and industrial appearance. <sup>17</sup>															
24F-E3	SP/SP	2,400	1,200	650	650	90 <sup>24</sup>	1.8	1,300	470	155	80	1.5	950	1,100	1.5
The following combination is balanced and intended for members continuous or cantilevered over supports and provides equal capacity in both positive and negative bending.															
24F-E4	SP/SP	2,400	2,400	650	650	200	1.8	2,000	560	175	90	1.6	1,250	1,750	1.6
Wet-use factors <sup>2</sup>		0.8	0.8	0.53	0.53	0.875	0.833	0.8	0.53	0.875	0.875	0.833	0.8	0.73	0.833

<sup>1</sup>The combinations in this table are applicable to members consisting of four or more laminations and are intended primarily for members stressed in bending due to loads applied perpendicular to the wide faces of the laminations. Design values are tabulated, however, for loading both perpendicular and parallel to the wide faces of the laminations. For combinations and design values applicable to members loaded primarily axially or parallel to the wide faces of the laminations, see Table 23-I-C-1, Part B. For members of two or three laminations, see Table 23-I-C-1, Part B.

<sup>2</sup>The tabulated design values are for dry conditions of use. To obtain wet-use design values, multiply the tabulated values by the factors shown at the end of the table.

<sup>3</sup>The tabulated design values are for normal duration of loading. For other durations of loading, see Section 2304.3.4.

<sup>4</sup>The combination symbols relate to a specific combination of grades and species that will provide the design values shown for the combinations. The first two numbers in the combination symbol correspond to the design value in bending shown in Column 3. The letter in the combination symbol (either a "V" or an "E") indicates whether the combination is made from visually graded (V) or E-rated (E) lumber in the outer zones.

<sup>5</sup>The symbols used for species are AC = Alaska cedar, DF = Douglas fir-larch, DFS = Douglas fir south, HF = hem-fir, WW = softwood species, SP = southern pine and ES = eastern spruce. (N3 refers to No. 3 structural joists and planks or structural light-framing grade.) Softwood species (WW) and eastern spruce are included in the general category of western species although eastern spruce and some softwood species are produced in other areas.

<sup>6</sup>The duration of load modification factors given in Section 2304.3.4 shall not apply.

<sup>7</sup>The tabulated design values in bending are applicable to members 12 inches (305 mm) or less in depth. For members greater than 12 inches (305 mm) in depth, the requirements of Section 2312.4.5 apply.

<sup>8</sup>The design values in bending about the x-x axis ( $F_{bx}$ ) in this column for bending members shall be multiplied by 0.75 when the member is manufactured without the required special tension laminations.

- <sup>9</sup>Design values in this column are for extreme fiber stress in bending when the member is loaded such that the compression zone laminations are subjected to tensile stresses. The values in this column may be increased 200 pounds per square inch (psi) (1.38 N/mm<sup>2</sup>) where end-joint spacing restrictions are applied to the compression zone when stressed in tension.
- <sup>10</sup>Footnote 7 to Table 23-I-C-1, Part B, also applies.
- <sup>11</sup>These values for horizontal shear,  $F_{vyy}$ , apply to members manufactured using multiple-piece laminations with unbonded edge joints. For members manufactured using single-piece laminations or using multiple-piece laminations with bonded edge joints, the horizontal shear values in Column 11 apply.
- <sup>12</sup>Where specified, this value may be increased to 650 psi (4.48 N/mm<sup>2</sup>) by providing in the bearing area at least one dense 2-inch (51 mm) nominal thickness lamination of Douglas fir-larch for western species combinations, or southern pine for southern pine combinations. These dense laminations must be backed by a medium-grain lamination of the same species.
- <sup>13</sup>For bending members greater than 15 inches (381 mm) in depth, the design value for compression stress perpendicular to grain is 650 psi (4.48 N/mm<sup>2</sup>) on the tension face.
- <sup>14</sup>When Douglas fir south is used in place of all of the western wood laminations required in western species combinations 16F-V1, 16F-V4, 20F-V1, 20F-V5, 22F-V1, 22F-V5, 24F-V1, 24F-V6, 16F-E1, 16F-E4, 20F-E1, 20F-E4, 22F-E3, 24F-E6 and 24F-E7, the design value for horizontal shear is the same as for combinations using all Douglas fir-larch [ $F_{vxx} = 165$  psi (1.14 N/mm<sup>2</sup>) and  $F_{vyy} = 145$  psi (1.00 N/mm<sup>2</sup>) for L3; and  $F_{vxx} = 90$  psi (0.62 N/mm<sup>2</sup>) and  $F_{vyy} = 135$  psi (0.93 N/mm<sup>2</sup>) for N3].
- <sup>15</sup>The following species may be used for softwood species (WW), provided the design values in horizontal shear in Column 7 ( $F_{vx}$ ) and in Column 11 ( $F_{vy}$ ) are reduced by 10 psi (0.07 N/mm<sup>2</sup>), and the design values in horizontal shear in Column 12 ( $F_{vy}$ ) are reduced by 5 psi (0.03 N/mm<sup>2</sup>): coast sitka spruce, coast species, eastern white pine (north) and western white pine.
- <sup>16</sup>Where specified, this value may be increased by providing at least two 2-inch (51 mm) nominal thickness Douglas fir-larch laminations in the bearing area. The compression-perpendicular-to-grain design values for Douglas fir-larch are 560 psi (3.86 N/mm<sup>2</sup>) for medium grain and 650 psi (4.48 N/mm<sup>2</sup>) for dense.
- <sup>17</sup>These combinations are for dry conditions of use only because they may contain wane. They are recommended for industrial appearance grade and for straight or slightly cambered members only. If wane is omitted these restrictions do not apply.
- <sup>18</sup>The following species may be used for softwood species (WW), provided the design values in modulus of elasticity ( $E_x$  and  $F_y$ ) in Columns 8 and 13 are reduced by 100,000 psi (689 N/mm<sup>2</sup>): western cedars, western cedars (north), white woods (western woods) and California redwood—open grain.
- <sup>19</sup>This value may be increased to 110 psi (0.76 N/mm<sup>2</sup>) when the member does not contain coarse-grain material; to 140 psi (0.96 N/mm<sup>2</sup>) when the member does not contain wane on both sides or the member does not contain coarse-grain material and wane on one side; to 165 psi (1.14 N/mm<sup>2</sup>) when the member does not contain coarse-grain material and wane on both sides.
- <sup>20</sup>This value may be increased to 140 psi (0.96 N/mm<sup>2</sup>) for softwood species (WW) and to 155 psi (1.07 N/mm<sup>2</sup>) for hem-fir when the member does not contain wane on both sides; to 115 psi (0.79 N/mm<sup>2</sup>) for softwood species (WW) and to 130 psi (0.90 N/mm<sup>2</sup>) for hem-fir when the member does not contain wane on one side.
- <sup>21</sup>The compression-perpendicular-to-grain design value of 255 psi (1.76 N/mm<sup>2</sup>) is based on the lowest strength species of the western woods group. If at least one 2-inch (51 mm) nominal thickness lamination of E-rated hem-fir with the same E value, or E-rated Douglas fir-larch 200,000 psi (1378 N/mm<sup>2</sup>) higher in modulus of elasticity (E) than that specified is used in the bearing area on the face of the member subjected to the compression-perpendicular-to-grain stress,  $F_c \perp$  may be increased to 375 psi (2.58 N/mm<sup>2</sup>). If at least two 2-inch (51 mm) nominal thickness laminations of E-rated hem-fir with the same E value, or E-rated Douglas fir-larch 200,000 psi (1378 N/mm<sup>2</sup>) higher in modulus of elasticity than that specified are used in the bearing area on the face of the member subjected to the compression-perpendicular-to-grain stress,  $F_c \perp$  may be increased to 500 psi (3.45 N/mm<sup>2</sup>).
- <sup>22</sup>E-rated Douglas fir-larch 200,000 psi (1378 N/mm<sup>2</sup>) higher in modulus of elasticity may be substituted for the specified E-rated hem-fir.
- <sup>23</sup>Where specified, this value may be increased to 650 psi (4.48 N/mm<sup>2</sup>) by providing in the bearing area at least one 2-inch (51 mm) nominal thickness lamination of Douglas fir-larch for western species combinations, or one 2-inch (51 mm) nominal thickness lamination of southern pine for southern pine combinations having a modulus of elasticity (E) value 200,000 psi (1378 N/mm<sup>2</sup>) higher than the E value specified.
- <sup>24</sup>This value may be increased to 140 psi (0.96 N/mm<sup>2</sup>) when the member does not contain coarse-grain material or when the member does not contain wane on both sides; to 165 psi (1.14 N/mm<sup>2</sup>) when members do not contain coarse-grain material or wane on one side; or to 200 psi (1.38 N/mm<sup>2</sup>) when the member does not contain both coarse-grain material and wane on both sides of the member.

**TABLE 23-I-C-1, PART B—ALLOWABLE UNIT STRESSES FOR STRUCTURAL GLUED-LAMINATED TIMBER FOR NORMAL LOADING DURATION<sup>1,2,3</sup>**

Members stressed principally in axial tension or compression or in bending with load applied parallel to the wide faces of the laminations

COMBINATION SY MBOL	SPECIES <sup>4</sup>	GRADE <sup>5</sup>	MODULUS OF ELASTICITY $E^6$ $\times 10^6$ psi	COMPRES-SION PER-PENDICU-LAR TO GRAIN $F_c \perp$ psi	AXIALLY LOADED						BENDING ABOUT Y-Y AXIS				BENDING ABOUT X-X AXIS					
					Tension Parallel to Grain $F_t$			Compression Parallel to Grain $F_c$			Loaded Parallel to Wide Faces of Laminations		Extreme Fiber in Bending <sup>7</sup> $F_{byy}$		Horizontal Shear <sup>8</sup> $F_{vyv}$		Loaded Perpendicular to Wide Faces of Laminations		Extreme Fiber in Bending <sup>9</sup> $F_{dxx}$	Horizontal Shear $F_{vxx}$ 2 or More Lams psi
					2 or More Lams psi	4 or More Lams psi	2 or 3 Lams psi	4 or More Lams psi	3 Lams psi	2 Lams psi	4 or More Lams (For members with multiple-piece laminations.) <sup>10</sup>	4 or More Lams psi	3 Lams psi	2 Lams psi	2 Lams to 15 in. Deep <sup>11</sup> psi	4 or More Lams <sup>12,13</sup> psi				
					$\times 0.00689$ for N/mm <sup>2</sup>															
1	2	3	4	5	6	7	8	9	10	11	12	13	14	15	16	17	18			
<b>Visually Graded Western Species</b>																				
1	DF	L3	1.5	560 <sup>14</sup>	900	1,550	1,200	1,450	1,250	1,000	75	145	135	125	1,250	1,500	165			
2		L2	1.7	560 <sup>14</sup>	1,250	1,900	1,600	1,800	1,600	1,300	75	145	135	125	1,700	2,000	165			
3		L2D	1.8	650	1,450	2,300	1,850	2,100	1,850	1,550	75	145	135	125	2,000	2,300	165			
4		L1CL	1.9	590 <sup>14</sup>	1,400	2,100	1,900	2,200	2,000	1,650	75	145	135	125	1,900	2,200	165			
5		L1	2.0	650	1,600	2,400	2,100	2,400	2,100	1,800	75	145	135	125	2,200	2,400	165			
6		N3C	1.4	470	350	875	550	550	550	550	60	120	115	105	450	—	140			
7		N3M	1.5	560	900	1,550	700	1,450	1,250	1,000	75	145	135	125	1,000	—	165			
8		N2	1.6	560 <sup>14</sup>	1,000	1,550	1,150	1,600	1,550	1,300	75	145	135	125	1,350	1,600	165			
9		N2D	1.8	650	1,150	1,800	1,350	1,850	1,800	1,500	75	145	135	125	1,600	1,850	165			
10		N1	1.8	560 <sup>14</sup>	1,300	1,950	1,450	1,950	1,750	1,500	75	145	135	125	1,750	2,100	165			
11		N1D	2.0	650	1,500	2,300	1,700	2,300	2,100	1,750	75	145	135	125	2,100	2,400	165			
12		SS	1.8	560 <sup>14</sup>	1,400	1,950	1,650	2,100	1,950	1,650	75	145	135	125	1,900	2,200	165			
13		SSD	2.0	650	1,600	2,300	1,950	2,400	2,300	1,950	75	145	135	125	2,200	2,400	165			
14	HF	L3	1.3	375 <sup>14</sup>	800	1,100	975	1,200	1,050	850	70	135	130	115	1,100	1,300	155			
15		L2	1.4	375 <sup>14</sup>	1,050	1,350	1,300	1,500	1,350	1,100	70	135	130	115	1,450	1,700	155			
16		L1	1.6	375 <sup>14</sup>	1,200	1,500	1,450	1,750	1,550	1,300	70	135	130	115	1,600	1,900	155			
17		L1D	1.7	500	1,400	1,750	1,700	2,000	1,850	1,550	70	135	130	115	1,900	2,200	155			
18		N3	1.3	375	425	900	575	700	700	700	70	135	130	115	575	—	155			
19		N2	1.4	375 <sup>14</sup>	850	1,300	975	1,350	1,300	1,100	70	135	130	115	1,150	1,350	155			
20		N1	1.6	375 <sup>14</sup>	975	1,450	1,250	1,550	1,500	1,250	70	135	130	115	1,350	1,550	155			
21		SS	1.6	375 <sup>14</sup>	1,100	1,450	1,350	1,750	1,650	1,400	70	135	130	115	1,500	1,750	155			

22	WW	L3	1.0 <sup>15</sup>	255	525	850	675	800	700	550	60 <sup>16</sup>	120 <sup>16</sup>	115 <sup>16</sup>	105 <sup>16</sup>	725	850	140 <sup>16</sup>	
23		N3	1.0 <sup>15</sup>	255	275	625	450	450	450	450	60 <sup>16</sup>	120 <sup>16</sup>	115 <sup>16</sup>	105 <sup>16</sup>	400	—	140 <sup>16</sup>	
24		N2	1.1 <sup>15</sup>	255	550	900	700	900	875	725	60 <sup>16</sup>	120 <sup>16</sup>	115 <sup>16</sup>	105 <sup>16</sup>	775	900	140 <sup>16</sup>	
25		N1	1.2 <sup>15</sup>	255	650	1,000	875	1,050	1,000	850	60 <sup>16</sup>	120 <sup>16</sup>	115 <sup>16</sup>	105 <sup>16</sup>	875	1,050	140 <sup>16</sup>	
26	DFS	SS	1.2 <sup>15</sup>	255	750	1,000	1,000	1,150	1,100	925	60 <sup>16</sup>	120 <sup>16</sup>	115 <sup>16</sup>	105 <sup>16</sup>	1,000	1,150	140 <sup>16</sup>	
59		L3	1.1	500	800	1,400	1,050	1,200	1,050	850	75	145	135	125	1,050	1,250	165	
60		L2	1.3	500	1,050	1,750	1,400	1,750	1,550	1,150	75	145	135	125	1,450	1,700	165	
61		L1	1.5	650	1,350	2,200	1,850	2,000	1,800	1,500	75	145	135	125	1,850	2,200	165	
64	ES	D	1.3	300	575	925	850	950	925	875	65	125	120	110	800	950	145	
65		D4	1.5	450	825	1,050	1,050	1,350	1,350	1,350	65	125	120	110	1,150	1,350	145	
66		C4	1.5	450	975	1,550	1,200	1,750	1,750	1,700	65	125	120	110	1,400	1,650	145	
67		C6	1.7	450	1,100	1,850	1,450	1,950	1,950	1,900	65	125	120	110	1,550	1,800	145	
68		B	1.7	450	1,350	1,850	1,800	2,250	2,200	2,150	65	125	120	110	1,900	2,250	145	
69		AC	L3	1.3	470	700	1,150	1,150	1,000	875	700	80	165	160	140	1,000	1,150	190
70		AC	L2	1.4	470	1,000	1,450	1,550	1,250	1,100	925	80	165	160	140	1,350	1,550	190
71	AC	L1D	1.7	560	1,250	1,900	2,050	1,650	1,500	1,250	80	165	160	140	1,700	2,000	190	
72	AC	L1S	1.7	560	1,250	1,900	2,050	1,650	1,500	1,250	80	165	160	140	1,700	2,000	190	
<b>E-Rated Western Species</b>																		
27	DF	1/2-1.8E	1.8	650	900	1,750	1,200	1,450	1,250	1,000	75	145	135	125	1,250	1,500	165	
28		1/2-2.0E	2.0	650	1,100	2,000	1,400	1,450	1,250	1,000	75	145	135	125	1,500	1,750	165	
29		1/2-2.2E	2.2	650	1,250	2,300	1,550	1,650	1,400	1,150	75	145	135	125	1,700	2,000	165	
30		1/6-1.8E	1.8	650	1,550	2,100	1,700	2,400	2,400	2,100	75	145	135	125	1,800	2,100	165	
31		1/6-2.0E	2.0	650	1,800	2,400	1,900	2,400	2,400	2,400	75	145	135	125	2,100	2,400	165	
32		1/6-2.2E	2.2	650	1,800	2,400	2,100	2,400	2,400	2,400	75	145	135	125	2,300	2,400	165	
62	HF	1/2-2.1E	2.1	650	1,150	2,200	1,500	1,550	1,350	1,100	75	145	135	125	1,600	1,900	165	
63		1/6-2.1E	2.1	650	1,800	2,400	2,000	2,400	2,400	2,400	75	145	135	125	2,200	2,400	165	
33		1/2-1.5E	1.5	500	800	1,050	950	1,200	1,050	850	70	135	130	115	1,100	1,300	155	
34		1/2-1.8E	1.8	500	900	1,300	1,200	1,450	1,250	1,000	70	135	130	115	1,250	1,500	155	
35		1/2-2.0E	2.0	500	1,100	1,550	1,400	1,450	1,250	1,000	70	135	130	115	1,500	1,750	155	
36		1/4-1.5E	1.5	500	1,200	1,450	1,300	2,100	1,900	1,700	70	135	130	115	1,400	1,650	155	
37	WW	1/6-1.8E	1.8	500	1,550	1,950	1,700	2,400	2,400	2,100	70	135	130	115	1,650	2,100	155	
38		1/6-2.0E	2.0	500	1,800	2,400	1,900	2,400	2,400	2,400	70	135	130	115	2,100	2,400	155	
39		1/2-1.5E	1.5	255	800	1,200	950	1,200	1,050	850	60 <sup>16</sup>	120 <sup>16</sup>	115 <sup>16</sup>	105 <sup>16</sup>	1,100	1,300	140 <sup>16</sup>	
40		1/2-1.8E	1.8	255	900	1,500	1,200	1,450	1,250	1,000	60 <sup>16</sup>	120 <sup>16</sup>	115 <sup>16</sup>	105 <sup>16</sup>	1,250	1,500	140 <sup>16</sup>	
41	WW	1/2-2.0E	2.0	255	1,100	1,750	1,400	1,450	1,250	1,000	60 <sup>16</sup>	120 <sup>16</sup>	115 <sup>16</sup>	105 <sup>16</sup>	1,500	1,750	140 <sup>16</sup>	
42		1/4-1.5E	1.5	255	1,200	1,550	1,300	2,100	1,900	1,700	60 <sup>16</sup>	120 <sup>16</sup>	115 <sup>16</sup>	105 <sup>16</sup>	1,400	1,650	140 <sup>16</sup>	

(Continued)

TABLE 23-I-C-1, PART B—ALLOWABLE UNIT STRESSES FOR STRUCTURAL GLUED-LAMINATED TIMBER FOR NORMAL LOADING DURATION<sup>1,2,3</sup>—(Continued)

COMBINATION SYMBOL	SPECIES <sup>4</sup>	GRADE <sup>5</sup>	MODULUS OF ELASTICITY $E^6$ $\times 10^6$ psi	COMPRESSION PERPENDICULAR TO GRAIN $F_c \perp$ psi	AXIALLY LOADED								BENDING ABOUT Y-Y AXIS				BENDING ABOUT X-X AXIS		
					Tension Parallel to Grain $F_t$		Compression Parallel to Grain $F_c$		Extreme Fiber in Bending <sup>7</sup> $F_{yy}$				Horizontal Shear <sup>8</sup> $F_{yy}$				Extreme Fiber in Bending <sup>9</sup> $F_{xx}$		
					2 or More Lams psi	4 or More Lams psi	2 or 3 Lams psi	4 or More Lams psi	3 Lams psi	2 Lams psi	4 or More Lams (For members with multiple-piece laminations.) <sup>10</sup>	4 or More Lams psi	3 Lams psi	2 Lams psi	2 Lams to 15 in. Deep <sup>11</sup> psi	4 or More Lams <sup>12,13</sup> psi	Horizontal Shear $F_{yx}$ 2 or More Lams psi		
					$\times 0.00689$ for N/mm <sup>2</sup>														
1	2	3	4	5	6	7	8	9	10	11	12	13	14	15	16	17	18		
<b>E-Rated Western Species—(Continued)</b>																			
43	WW	1/6-1.8E	1.8	255	1,550	1,950	1,700	2,400	2,400	2,100	60 <sup>16</sup>	120 <sup>16</sup>	115 <sup>16</sup>	105 <sup>16</sup>	1,800	2,100	140 <sup>16</sup>		
44		1/6-2.0E	2.0	255	1,800	2,200	1,900	2,400	2,400	2,400	60 <sup>16</sup>	120 <sup>16</sup>	115 <sup>16</sup>	105 <sup>16</sup>	2,100	2,400	140 <sup>16</sup>		
<b>Visually Graded Southern Pine</b>																			
45	SP	N3C	1.1	470	325	850	550	550	550	550	60	120	115	105	450	—	140		
46		N3M	1.3	560	900	1,500	675	1,450	1,250	1,000	90	175	165	150	1,000	—	200		
47		N2M <sup>17</sup>	1.4	560 <sup>14</sup>	1,200	1,900	1,150	1,750	1,550	1,300	90	175	165	150	1,400	1,600	200		
48		N2D <sup>17</sup>	1.7	650	1,400	2,200	1,350	2,000	1,800	1,500	90	175	165	150	1,600	1,900	200		
49		N1M <sup>17</sup>	1.7	560 <sup>14</sup>	1,350	2,100	1,450	1,950	1,750	1,500	90	175	165	150	1,800	2,100	200		
50		N1D <sup>17</sup>	1.9	650	1,550	2,300	1,700	2,300	2,100	1,750	90	175	165	150	2,100	2,400	200		
51		SSM	1.7	560 <sup>14</sup>	1,300	1,900	1,600	2,100	1,950	1,650	90	175	165	150	1,750	2,100	200		
52		SSD	1.9	650	1,500	2,200	1,850	2,400	2,300	1,950	90	175	165	150	2,100	2,400	200		
<b>E-Rated Southern Pine</b>																			
53	SP	1/2-1.8E	1.8	650	900	1,900	1,200	1,450	1,250	1,000	90	175	165	150	1,250	1,500	200		
54		1/2-2.0E	2.0	650	1,100	2,300	1,400	1,450	1,250	1,000	90	175	165	150	1,600	1,750	200		
55		1/2-2.2E	2.2	650	1,250	2,400	1,550	1,650	1,400	1,150	90	175	165	150	1,700	2,000	200		
56		1/6-1.8E	1.8	650	1,550	1,850	1,700	2,400	2,400	2,100	90	175	165	150	1,800	2,100	200		
57		1/6-2.0E	2.0	650	1,800	2,400	1,900	2,400	2,400	2,400	90	175	165	150	2,100	2,400	200		
58		1/6-2.2E	2.2	650	1,800	2,400	2,100	2,400	2,400	2,400	90	175	165	150	2,300	2,400	200		
Wet-use factors <sup>2</sup>		—	0.833	0.53	0.8	0.73	0.73	0.8	0.8	0.8	0.875	0.875	0.875	0.875	0.8	0.875	0.875		

- <sup>1</sup>The combinations in this table are intended primarily for members loaded either axially or in bending with the loads acting parallel to the wide faces of the laminations. Design values for bending due to loading applied perpendicular to the wide faces of the laminations are also included; however, the combinations in Table 23-I-C-1, Part A, are usually better suited for this condition of loading. The design values for bending about the x-x axis ( $F_{bxx}$ ) shown in Column 16 are for members from two laminations to 15 inches (381 mm) deep without tension laminations. Design values approximately 15 percent higher for members with four or more laminations are shown in Column 17. These higher design values, however, require special tension laminations which may not be readily available.
- <sup>2</sup>The tabulated design values are for dry conditions of use. To obtain wet-use design values, multiply the tabulated values by the factors shown at the end of the table.
- <sup>3</sup>The tabulated design values are for normal duration of loading. For other durations of loading, see Section 2304.3.4.
- <sup>4</sup>The symbols used for species are AC = Alaska cedar, DF = Douglas fir-larch, DFS = Douglas fir south, ES = eastern spruce, HF = hem-fir, WW = softwood species, and SP = southern pine.
- <sup>5</sup>Grade designations are as follows: softwood species (WW) and eastern spruce are included in general category of western species although eastern spruce and some softwood species are produced in other areas.

#### Visually Graded Western Species

- L1 is L1 laminating grade (dense for Douglas fir-larch and Douglas fir south).  
 L1D is L1 dense laminating grade for hem-fir.  
 L1S is a special grade of Alaska cedar.  
 L1CL is L1 close grain laminating grade.  
 L2D is L2 laminating grade (dense).  
 L2 is L2 laminating grade (medium grain).  
 L3 is L3 laminating grade (medium grain for Douglas fir-larch, Douglas fir south and hem-fir).  
 SSD is dense select structural, structural joists and planks, or structural light-framing grade (dense).  
 SS is select structural, structural joists and planks, or structural light-framing grade (medium grain for Douglas fir-larch).  
 N1D is dense No. 1 structural joists and planks, or structural light-framing grade (dense).  
 N1 is No. 1 structural joists and planks, or structural light-framing grade (medium grain for Douglas fir-larch).  
 N2D is dense No. 2 structural joists and planks or structural light-framing grade (medium grain for Douglas fir-larch dense).  
 N2 is No. 2 structural joists and planks or structural light-framing grade (medium grain for Douglas fir-larch).  
 N3M is No. 3 structural joists and planks, or structural light-framing grade (medium grain).  
 N3C is No. 3 structural joists and planks, or structural light-framing grade (coarse grain).  
 N3 is No. 3 structural joists and planks, or structural light-framing grade.

#### Visually Graded Southern Pine

- SSD is dense select structural, structural joists and planks, or structural light-framing grade (dense).  
 SSM is select structural, structural joists and planks, or structural light-framing grade (medium grain).  
 N1D is No. 1 dense structural joists and planks or structural light-framing grade or No. 1 boards graded as dense.  
 N1M is No. 1 structural joists and planks, or structural light-framing grade or No. 1 boards all with a medium grain rate of growth.  
 N2D is No. 2 dense structural joists and planks, or structural light-framing grade or No. 2 boards graded as dense.  
 N2M is No. 2 structural joists and planks, or structural light-framing grade or No. 2 boards all with medium grain rate of growth.  
 N3M is No. 3 structural joists and planks, or structural light-framing grade or No. 3 boards all with a medium grain rate of growth.  
 N3C is No. 3 structural joists and planks, or structural light-framing grade or No. 3 boards all with coarse grain rate of growth.

#### E-Rated Grades—All Species

- $1/6$ -2.2E has  $1/6$  edge characteristic with 2.2E.  
 $1/6$ -2.1E has  $1/6$  edge characteristic with 2.1E.  
 $1/6$ -2.0E has  $1/6$  edge characteristic with 2.0E.

(Continued)

## FOOTNOTES TO TABLE 23-I-C-1, Part B—(Continued)

- $1/6$ -1.8E has  $1/6$  edge characteristic with 1.8E.  
 $1/4$ -1.5E has  $1/4$  edge characteristic with 1.5E.  
 $1/2$ -2.2E,  $1/2$ -2.1E,  $1/2$ -2.0E,  $1/2$ -1.8E are E-rated grades with edge characteristics occupying up to one half of cross section.

<sup>6</sup>The duration of load modification factors given in Section 2304.3.4 shall not apply.

<sup>7</sup>The values of  $F_{b_{yy}}$  were calculated based on members 12 inches (305 mm) in depth (bending about Y-Y axis). When the depth is less than 12 inches (305 mm), the values of  $F_{b_{yy}}$  can be increased by multiplying by the following factors.

DEPTH, (inches) × 25.4 for mm	MULTIPLYING FACTOR
10.75	1.01
8.75	1.04
6.75	1.07
5.125	1.10
3.125	1.16

<sup>8</sup>The design values in horizontal shear contained in this table are based on members without wane.

<sup>9</sup>The tabulated design values in bending are applicable to members 12 inches (305 mm) or less in depth. For members greater than 12 inches (305 mm) in depth, the requirements of Section 2312.4.5 apply.

<sup>10</sup>These values for horizontal shear,  $F_{v_{yy}}$ , apply to members manufactured using multiple-piece laminations with unbonded edge joints. For members using single-piece laminations or using multiple-piece laminations with bonded edge joints, the horizontal shear values tabulated in Columns 13, 14 and 15 apply.

<sup>11</sup>The design values in Column 16 are for members of from two laminations to 15 inches (381 mm) in depth without tension laminations.

<sup>12</sup>The design values in Column 17 are for members of four or more laminations in depth and require special tension laminations. When these values are used in design and the member is specified by combination symbol, the designer should also specify the required design value in bending.

<sup>13</sup>When special tension laminations are not used, the design values in bending about the x-x axis ( $F_{b_{xx}}$ ) shall be multiplied by 0.75 for bending members over 15 inches (381 mm) deep. For bending members 15 inches (381 mm) and less in depth, use the design values in Column 16.

<sup>14</sup>When tension laminations are used to obtain the design value for  $F_{b_{xx}}$  shown in Column 16, the compression perpendicular to grain value,  $F_{c \perp}$ , for the tension face may be increased to 650 psi (4.48 N/mm<sup>2</sup>) for Douglas fir-larch and southern pine, and to 500 psi (3.45 N/mm<sup>2</sup>) for hem-fir because the tension laminations are required to be dense.

<sup>15</sup>The following species may be used for softwood species (WW), provided the modulus of elasticity,  $E$ , is reduced by 100,000 psi (689 N/mm<sup>2</sup>): western cedars, western cedars (north), white woods (western woods) and California redwood—open grain.

<sup>16</sup>The following species may be used for softwood species (WW) provided the design values in horizontal shear in Column 12 ( $F_{v_{yy}}$ ) are reduced by 5 psi (0.03 N/mm<sup>2</sup>) and the design values in horizontal shear in Columns 13, 14 and 15 ( $F_{v_{yy}}$ ) and in Column 18 ( $F_{v_{xx}}$ ) are reduced by 10 psi (0.06 N/mm<sup>2</sup>): coast sitka spruce, coast species, western white pine and eastern white pine.

<sup>17</sup>Combinations 47, 48, 49 and 50 have more restrictive slope of grain requirements than the basic slope of grain of the grades of lumber used in order to obtain higher tension-parallel-to-grain values and design values in bending when loaded perpendicular to the wide faces of the laminations. The slopes of grain used to calculate the design values in Table 23-I-C-1, Part B, were: Combination 47, 1:14; Combination 48, 1:14; Combination 49, 1:16; and Combination 50, 1:14. When design stresses are lower than the design values shown, or when a less restrictive slope of grain provides the same design value, a less restrictive slope of grain may be used. The following table gives the design values of these combinations for various slopes of grain: values of  $F_{b_{xx}}$  in Column 5 are for members of two laminations to 15 inches (381 mm) in depth without tension laminations, and values in Column 6 are for members of four or more laminations with tension laminations.

SLOPE OF GRAIN 1	COMB. NO.	TENSION PARALLEL TO GRAIN ( $F_T$ ) 2 OR MORE LAMS psi 2	COMP. PARALLEL TO GRAIN ( $F_C$ ) 2 or 3 LAMS psi 3	COMP. PARALLEL TO GRAIN ( $F_C$ ) 4 OR MORE LAMS psi 4	BENDING ABOUT THE X-X AXIS $F_{Dxx}$		BENDING ABOUT THE Y-Y AXIS $F_{Dyy}$		
					2 Lams to 15 in. psi 5	4 or More Lams psi 6	2 Lams psi 7	3 Lams psi 8	4 or More Lams psi 9
					× 0.00689 for N/mm <sup>2</sup>				
1.12	47	1,200	1,150	1,900	1,400	1,600	1,300	1,550	1,750
	48	1,400	1,350	2,200	1,600	1,900	1,500	1,800	2,000
	49	1,300	1,450	1,900	1,750	2,100	1,500	1,750	1,950
	50	1,550	1,700	2,200	2,100	2,400	1,750	2,100	2,300
1.10	47	1,150	1,150	1,700	1,400	1,600	1,300	1,550	1,750
	48	1,350	1,350	2,000	1,600	1,900	1,500	1,800	2,000
	49	1,150	1,450	1,700	1,550	1,850	1,500	1,750	1,850
	50	1,350	1,700	2,000	1,800	2,100	1,750	2,100	2,100
1.8	47	1,000	1,150	1,500	1,350	1,600	1,300	1,550	1,600
	48	1,150	1,350	1,750	1,600	1,850	1,500	1,800	1,850
	49	—	—	—	—	—	—	—	—
	50	—	—	—	—	—	—	—	—

**TABLE 23-I-C-2, PART A—ALLOWABLE UNIT STRESSES FOR STRUCTURAL GLUED-LAMINATED CALIFORNIA REDWOOD VISUALLY GRADED<sup>1,2,3</sup>**  
**Members stressed principally in axial tension or compression or in bending with load applied perpendicular to the wide faces of the laminations**

COMBINATION SYMBOL	SPECIES OUTER LAMINATIONS/CORE LAMINATIONS <sup>4</sup>	BENDING ABOUT X-X AXIS						BENDING ABOUT Y-Y AXIS				AXIALLY LOADED		
		Loaded Parallel to Wide Faces of Laminations						Loaded Perpendicular to Wide Faces of Laminations						
		Extreme Fiber in Bending		Compression Perpendicular to Grain		Horizontal Shear $F_{vxx}$ psi	Modulus of Elasticity $F_{yx}$ x 10 <sup>6</sup> psi	Extreme Fiber in Bending <sup>5</sup> $F_{yy}$ psi	Compression Perpendicular to Grain Side Faces $F_c \perp yy$ psi	Horizontal Shear $F_{yy}$ psi	Modulus of Elasticity <sup>7</sup> $E_{yy}$ x 10 <sup>6</sup> psi	Tension Parallel to Grain $F_t$ psi	Compression Parallel to Grain $F_c$ psi	Modulus of Elasticity <sup>7</sup> $E$ x 10 <sup>6</sup> psi
		Tension Zone Stressed in Tension <sup>5</sup> $F_{txx}$ psi	Compression Zone Stressed in Tension <sup>6</sup> $F_{c \perp xx}$ psi	Tension Face $F_t \perp xx$ psi	Compression Face $F_c \perp xx$ psi									
× 0.00689 for N/mm <sup>2</sup>														
1	2	3	4	5	6	7	8	9	10	11	12	13	14	15
B-16F V1	CR/CR	1,600	800	315	315	125	1.1	1,400	270	110	1.5	900	1,400	1.1
Wet-use factors <sup>2</sup>		0.8	0.8	0.667	0.667	0.875	0.833	0.8	0.667	0.875	0.833	0.8	0.73	0.833

<sup>1</sup>The combinations in this table are intended primarily for members stressed in bending due to loads applied perpendicular to the wide faces of the laminations for members with four or more laminations. Stresses are tabulated, however, for loading both perpendicular and parallel to the wide faces of the laminations. For combinations and stresses applicable to members loaded primarily axially or parallel to the wide faces of the laminations, see Table 23-I-C-2, Part B. For members of two or three laminations, see Table 23-I-C-2, Part B.

<sup>2</sup>The tabulated design values are for dry conditions of use. To obtain wet-use design values, multiply the tabulated values by the factors shown at the end of the table.

<sup>3</sup>The tabulated design values are for normal duration of loading. For other durations of loading, see Section 2304.3.4.

<sup>4</sup>CR = California redwood.

<sup>5</sup>The tabulated design values in bending are applicable to members 12 inches (305 mm) or less in depth. For members greater than 12 inches (305 mm) in depth, the requirements of Section 2312.4.5 apply.

<sup>6</sup>Design values in this column are for extreme fiber stress in bending when the member is loaded such that the compression zone laminations are subjected to tensile stresses. The values in this column may be increased to 1,200 psi (8.27 N/mm<sup>2</sup>) when end-joint spacing restrictions are applied to the compression zone when stressed in tension.

<sup>7</sup>The duration of load modification factor given in Section 2304.3.4 shall not apply.

**TABLE 23-I-C-2, PART B—ALLOWABLE UNIT STRESSES FOR STRUCTURAL GLUED-LAMINATED CALIFORNIA REDWOOD VISUALLY GRADED<sup>1,2,3,4,5</sup>**  
**Members stressed principally in axial tension, axial compression or in bending with load applied parallel to the wide faces of the laminations**

COMBINATION SY MBOL	SPECIES <sup>6</sup>	GRADE <sup>7</sup>	MODULUS OF ELASTICITY <sup>8</sup> $E \times 10^6$ psi	COMPRES-SION PER-PENDICULAR TO GRAIN $F_c \perp$	AXIALLY LOADED			BENDING ABOUT Y-Y AXIS LOADED PARALLEL TO WIDE FACES OF LAMINATIONS						BENDING ABOUT X-X AXIS LOADED PERPENDICULAR TO WIDE FACES OF LAMINATIONS	
					Tension Parallel to Grain	Compression Parallel to Grain		Extreme Fiber in Bending <sup>9</sup>			Horizontal Shear			Extreme Fiber in Bending	Horizontal Shear
						4 or More Lams	2 or 3 Lams	4 or More Lams	3 Lams	2 Lams	4 or More Lams	3 Lams	2 Lams		
					$F_t$	$F_c$	$F_c$	$F_{byy}$	$F_{byy}$	$F_{byy}$	$F_{vyx}$	$F_{vyx}$	$F_{vyx}$	$F_{bxx}$	$F_{vxx}$
$\times 0.00689$ for $N/mm^2$															
1	2	3	4	5	6	7	8	9	10	11	12	13	14	15	16
B-1	CR	L5	1.0	315	875	1,350	1,350	1,450	1,300	1,100	110	105	95	1,200	125
B-2	CR	L4	1.0	315	875	1,350	1,350	1,450	1,300	1,100	110	105	95	1,200	125
B-3	CR	L3	1.2	315	1,000	1,550	1,550	1,450	1,300	1,100	110	105	95	1,350	125
B-4	CR	L2	1.2	315	1,000	1,600	1,600	1,500	1,350	1,150	110	105	95	1,350	125
B-5	CR	L1	1.2	315	1,000	1,600	1,600	1,600	1,500	1,250	110	105	95	1,350	125
Wet-use factors <sup>2</sup>			0.833	0.667	0.8	0.73	0.73	0.8	0.8	0.8	0.875	0.875	0.875	0.8	0.875

<sup>1</sup>The tabulated combinations in this table are intended primarily for members loaded either axially or in bending with the loads acting parallel to the wide faces of the laminations. Design values for bending due to loading applied perpendicular to the wide faces of the laminations are also included; however, the combination in Table 23-I-C-2, Part A, is usually better suited for this condition of loading for members with four or more laminations.

<sup>2</sup>The tabulated design values are for dry conditions of use. To obtain wet-use design values, multiply the tabulated values by the factors shown at the end of the table.

<sup>3</sup>The tabulated values are for normal duration of loading. For other durations of loading, see Section 2304.3.4.

<sup>4</sup>The tabulated design values for bending are applicable to members 12 inches (305 mm) or less in depth. For members greater than 12 inches (305 mm) in depth the requirements of Section 2312.4.5 apply.

<sup>5</sup>The combinations in this table are not intended for deep bending members when loaded perpendicular to the wide faces of the laminations. However, if members over 15 inches (381 mm) in depth are necessary, AITC 302-24 tension laminations are required and the designer must specify that the member is for use in bending about the x-x axis, in which case, the design value  $F_{bxx}$  is 1400 psi (9.65 N/mm<sup>2</sup>) for combinations B-1 and B-2 and 1600 psi (11.0 N/mm<sup>2</sup>) for B-3, B-4 and B-5.

<sup>6</sup>CR = California redwood.

(Continued)

## FOOTNOTES TO TABLE 23-I-C-2—(Continued)

<sup>7</sup>Grade designations are as follows:

Visually Graded—California redwood

L1 is L1 laminating grade (close grain).

L2 is L2 laminating grade (close grain).

L3 is L3 laminating grade (close grain).

L4 is L4 laminating grade (close grain).

L5 is L5 laminating grade (close grain).

<sup>8</sup>The duration of load modification factors given in Section 2304.3.4 shall not apply.

<sup>9</sup>The values of  $F_{byy}$  were calculated based on members 12 inches (305 mm) in depth (bending about Y-Y axis). When the depth is less than 12 inches (305 mm), the values of  $F_{byy}$  can be increased by multiplying by the following factors:

DEPTH, (inches) × 25.4 for mm	MULTIPLYING FACTOR
10.75	1.01
8.75	1.04
6.75	1.07
5.125	1.10
3.125	1.16

**TABLE 23-I-D, PART A—ALLOWABLE UNIT STRESSES FOR HARDWOOD GLUED-LAMINATED TIMBER<sup>1</sup>  
FOR NORMAL LOADING DURATION—DRY CONDITIONS OF USE<sup>2</sup>**

SPECIES	MULTIPLY THE APPROPRIATE STRESS MODULE IN PART B BY THE FACTORS BELOW TO DETERMINE ALLOWABLE STRESS FOR:			ALLOWABLE UNIT STRESS (pounds per square inch)	
	Extreme Fiber in Bending ( $F_b$ ) or Tension Parallel to Grain ( $F_t$ )	Compression Parallel to Grain ( $F_c$ )	Modulus of Elasticity ( $E$ ) <sup>3</sup>	× 0.00689 for N/mm <sup>2</sup>	
				Horizontal Shear ( $F_v$ )	Compression Perpendicular to Grain ( $F_{c\perp}$ )
1. Hickory, true and pecan	3.85	3.05	1.80	260	730
2. Beech, American	3.05	2.45	1.70	230	610
3. Birch, sweet and yellow	3.05	2.45	1.90	230	610
4. Elm, rock	3.05	2.45	1.40	230	610
5. Maple, black and sugar (hard maple)	3.05	2.45	1.70	230	610
6. Ash, commercial white	2.80	2.20	1.70	230	610
7. Oak, commercial red and white	2.80	2.05	1.60	230	610
8. Elm, American and slippery (white or soft elm)	2.20	1.60	1.40	190	310
9. Sweet gum (red or sap gum)	2.20	1.60	1.40	190	370
10. Tupelo, black (black gum)	2.20	1.60	1.20	190	370
11. Tupelo, water	2.20	1.60	1.30	190	370
12. Ash, black	2.00	1.30	1.30	170	370
13. Poplar, yellow	2.00	1.45	1.50	150	270
14. Cottonwood, eastern	1.55	1.20	1.20	110	180

TABLE 23-I-D, PART B—VALUES FOR USE IN COMPUTING WORKING STRESSES WITH FACTORS OF PART A TOGETHER WITH LIMITATIONS REQUIRED TO PERMIT THE USE OF SUCH STRESSES<sup>4</sup>

COMBINATION SYMBOL	RATIO OF SIZE OF MAXIMUM PERMITTED KNOT TO FINISHED WIDTH OF LAMINATION <sup>5</sup>	NUMBER OF LAMINATIONS <sup>6</sup>	EXTREME FIBER IN BENDING		TENSION PARALLEL TO GRAIN		COMPRESSION PARALLEL TO GRAIN		MODULUS OF ELASTICITY ( $E$ ) <sup>3</sup>
			Stress Module (psi)	Steepest Grain Slope	Stress Module (psi)	Steepest Grain Slope	Stress Module (psi)	Steepest Grain Slope	Stress Module (psi)
			× 0.00689 for N/mm <sup>2</sup>		× 0.00689 for N/mm <sup>2</sup>		× 0.00689 for N/mm <sup>2</sup>		× 0.00689 for N/mm <sup>2</sup>
A	0.1	4 to 14 15 or more	800 800	1:16 1:16	500 500	1:16 1:16	970 970	1:15 1:15	1,000,000
B	0.2	4 to 14 15 or more	770 800	1:16 1:16	500 500	1:16 1:16	920 930	1:15 1:15	1,000,000
C	0.3	4 to 14 15 or more	600 660	1:12 1:12	450 450	1:15 1:16	860 870	1:14 1:14	900,000
D	0.4	4 to 14 15 or more	450 520	1:8 1:8	350 350	1:10 1:12	780 810	1:12 1:12	800,000
E	0.5	4 to 14 15 or more	300 380	1:8 1:8	300 300	1:8 1:8	690 730	1:10 1:10	800,000

<sup>1</sup>The allowable unit stresses in bending obtained from Table 23-I-D apply when the wide faces of the laminations are normal to the direction of the load.

<sup>2</sup>Allowable stresses for dry conditions of use shall be applicable when the moisture content in service is 16 percent or less as in most covered structures. For wet conditions of use the following maximum percentage of the dry-use stresses shall be permitted:

$F_b$  (bending) and  $F_t$  (tension) 80 percent

$F_v$  (horizontal shear) 88 percent

$F_c$  (compression parallel to grain) 70 percent

$F_c \perp$  (compression perpendicular to grain) 67 percent

$E$  (modulus of elasticity) 83 percent

<sup>3</sup>The duration of load modification factors given in Section 2304.3.4 shall not apply.

<sup>4</sup>For modification of allowable unit stresses for structural glued-laminated lumber, see Section 2304.

<sup>5</sup>Factors for knot sizes of 0.1 and 0.2 are identical in case of extreme fiber in bending and in tension parallel to grain because slope of grain of 1:16 is a greater limitation than knot size. The smaller knot size may be specified for reasons other than strength.

<sup>6</sup>When laminations of different thicknesses are used, divide the depth of the member by the thickest lamination used and then assume the quotient to be the number of laminations in the member for use in determining the allowable stress.

**TABLE 23-I-E—ALLOWABLE UNIT STRESSES FOR TREATED  
ROUND TIMBER POLES AND PILES<sup>1</sup>**  
(Values for normal load duration and wet conditions of use, pounds per square inch)

SPECIES	COMPRESSION PARALLEL TO GRAIN <sup>2</sup>	EXTREME FIBER IN BENDING <sup>2</sup>	HORIZONTAL SHEAR	COMPRESSION PERPENDICULAR TO GRAIN <sup>1</sup>	MODULUS OF ELASTICITY
	$F_c$	$F_b$	$F_v$	$F_c \perp$	$E$
	× 0.00689 for N/mm <sup>2</sup>				
1. Pacific Coast Douglas fir <sup>3,4</sup>	1,250	2,450	115	230	1,500,000
2. Southern pine <sup>3,5</sup>	1,200	2,400	110	250	1,500,000
3. Red oak <sup>6</sup>	1,100	2,450	135	350	1,250,000
4. Red pine <sup>7</sup>	900	1,900	85	155	1,280,000

<sup>1</sup>The form factor of Section 2304.3.7 for bending members of circular cross section is incorporated in the allowable unit stresses for extreme fiber in bending as listed within the table.

<sup>2</sup>The allowable values listed in Table 23-I-E for compression parallel to grain and extreme fiber in bending are based on load-sharing principles such as occur in a pile cluster. For piles which support their own specific load, an additional safety factor of 1.25 shall be used with compression parallel to grain values and an additional safety factor of 1.30 shall be used with extreme fiber in bending values.

<sup>3</sup>Design values in compression parallel to the grain for Pacific Coast Douglas fir and southern pine may be increased 0.20 percent for each foot (305 mm) of length from the tip of the pile to the critical section. The increase shall not exceed 10 percent for any single pile; however, the increase is cumulative with the increase in section properties due to taper from the pile tip to the critical section.

<sup>4</sup>Pacific Coast Douglas fir includes Douglas fir from west of the crest of the Cascade Mountains in Oregon, Washington and northern California and west of the crest of the Sierra Nevada Mountains in the rest of California. For fastener design, use Douglas fir-larch design values.

<sup>5</sup>Southern pine values apply to longleaf, slash, loblolly and shortleaf pines.

<sup>6</sup>Red oak values apply to northern and southern red oak.

<sup>7</sup>Red pine values apply to red pine grown in the United States. For fastener design, use northern pine design values.

**TABLE 23-I-F—HOLDING POWER OF BOLTS<sup>1,2,3</sup> FOR DOUGLAS FIR-LARCH**  
 (See Division III where members are not of equal size and for values in other species.)

<i>p</i> = safe loads parallel to grain, in pounds.							
<i>q</i> = safe loads perpendicular to grain, in pounds.							
× 4.45 for N							
LENGTH OF BOLT IN MAIN WOOD MEMBER <sup>4</sup> (Inches)		DIAMETER OF BOLT (Inches)					
		<sup>3</sup> / <sub>8</sub>	<sup>1</sup> / <sub>2</sub>	<sup>5</sup> / <sub>8</sub>	<sup>3</sup> / <sub>4</sub>	<sup>7</sup> / <sub>8</sub>	1
× 25.4 for mm							
1 <sup>1</sup> / <sub>2</sub>	Single <i>p</i>		480	600	720	850	970
	Shear <i>q</i>	5	300	360	420	470	530
1 <sup>1</sup> / <sub>2</sub>	Double <i>p</i>		1,050	1,310	1,580	1,840	2,100
	Shear <i>q</i>	5	730	1,040	1,170	1,260	1,350
2 <sup>1</sup> / <sub>2</sub>	Single <i>p</i>		720	1,010	1,210	1,410	1,610
	Shear <i>q</i>		460	590	690	780	880
2 <sup>1</sup> / <sub>2</sub>	Double <i>p</i>		1,430	2,190	2,630	3,060	3,500
	Shear <i>q</i>	5	710	1,180	1,540	1,960	2,250
3 <sup>1</sup> / <sub>2</sub>	Single <i>p</i>			1,120	1,610	1,970	2,260
	Shear <i>q</i>			700	870	1,060	1,230
3 <sup>1</sup> / <sub>2</sub>	Double <i>p</i>		1,430	2,240	3,220	4,290	4,900
	Shear <i>q</i>	5	970	1,410	1,750	2,130	2,580
5 <sup>1</sup> / <sub>2</sub>	Single <i>p</i>					2,190	2,860
	Shear <i>q</i>					1,330	1,540
5 <sup>1</sup> / <sub>2</sub>	Double <i>p</i>		5	2,240	3,220	4,390	5,730
	Shear <i>q</i>			1,460	2,050	2,660	3,080
7 <sup>1</sup> / <sub>2</sub>	Single <i>p</i>						
	Shear <i>q</i>						
7 <sup>1</sup> / <sub>2</sub>	Double <i>p</i>			2,240	3,220	4,390	5,730
	Shear <i>q</i>			1,460	2,050	2,720	3,470
9 <sup>1</sup> / <sub>2</sub>	Single <i>p</i>						
	Shear <i>q</i>						
9 <sup>1</sup> / <sub>2</sub>	Double <i>p</i>				5	5	5
	Shear <i>q</i>						
11 <sup>1</sup> / <sub>2</sub>	Single <i>p</i>						
	Shear <i>q</i>						
11 <sup>1</sup> / <sub>2</sub>	Double <i>p</i>					5	5
	Shear <i>q</i>						
13 <sup>1</sup> / <sub>2</sub>	Single <i>p</i>						
	Shear <i>q</i>						
13 <sup>1</sup> / <sub>2</sub>	Double <i>p</i>						5
	Shear <i>q</i>						

<sup>1</sup>Tabulated values are on a normal load-duration basis and apply to joints made of seasoned lumber used in dry locations. See Division III for other service conditions.

<sup>2</sup>Double shear values are for joints consisting of three wood members in which the side members are at least one half the thickness of the main member. Single shear values are for joints consisting of two wood members having a minimum thickness not less than that specified.

<sup>3</sup>See Division III for wood-to-metal bolted joints.

<sup>4</sup>The length specified is the length of the bolt in the main member of double shear joints or the length of the bolt in the thinner member of single shear joints.

<sup>5</sup>See Division III for the determination of the shear values.

**TABLE 23-I-G—SAFE LATERAL STRENGTH AND REQUIRED PENETRATION OF BOX AND COMMON WIRE NAILS DRIVEN PERPENDICULAR TO GRAIN OF WOOD**

SIZE OF NAIL	STANDARD LENGTH (Inches) × 25.4 for mm	WIRE GAGE	PENETRATION REQUIRED (Inches) × 25.4 for mm	LOADS (pounds) <sup>1, 2, 3</sup>	
				× 4.45 for N	
				Douglas Fir Larch or Southern Pine	Other Species
<b>Box Nails</b>					
6d	2	12 <sup>1</sup> / <sub>2</sub>	1.19	48	See Division III
8d	2 <sup>1</sup> / <sub>2</sub>	11 <sup>1</sup> / <sub>2</sub>	1.36	59	
10d	3	10 <sup>1</sup> / <sub>2</sub>	1.54	73	
12d	3 <sup>1</sup> / <sub>4</sub>	10 <sup>1</sup> / <sub>2</sub>	1.54	73	
16d	3 <sup>1</sup> / <sub>2</sub>	10	1.62	79	
20d	4	9	1.78	90	
30d	4 <sup>1</sup> / <sub>2</sub>	9	1.78	90	
40d	5	8	1.94	105	
<b>Common Nails</b>					
6d	2	11 <sup>1</sup> / <sub>2</sub>	1.36	59	See Division III
8d	2 <sup>1</sup> / <sub>2</sub>	10 <sup>1</sup> / <sub>4</sub>	1.57	76	
10d	3	9	1.78	90	
12d	3 <sup>1</sup> / <sub>4</sub>	9	1.78	90	
16d	3 <sup>1</sup> / <sub>2</sub>	8	1.94	105	
20d	4	6	2.30	124	
30d	4 <sup>1</sup> / <sub>2</sub>	5	2.48	134	
40d	5	4	2.70	147	
50d	5 <sup>1</sup> / <sub>2</sub>	3	2.93	151	
60d	6	2	3.16	171	

<sup>1</sup>See Division III for lateral strength values where metal side plates are used.

<sup>2</sup>See Division III for lateral strength values when considering wood diaphragm calculations.

<sup>3</sup>Tabulated values are on a normal load-duration basis and apply to joints made of seasoned lumber used in dry locations. See Division III for other service conditions.

**TABLE 23-I-H—SAFE RESISTANCE TO WITHDRAWAL OF COMMON WIRE NAILS Inserted Perpendicular to Grain of the Wood, in Pounds per Linear Inch of Penetration into the Main Member**

KIND OF WOOD	SIZE OF NAIL									
	6d	8d	10d	12d	16d	20d	30d	40d	50d	60d
	× 0.175 for N/mm									
1. Douglas fir, larch	28	32	36	36	40	47	50	55	60	64
2. Southern pine	35	41	46	46	50	59	64	70	76	81
3. Other species	See Division III									

**TABLE 23-I-I—MAXIMUM DIAPHRAGM DIMENSION RATIOS**

MATERIAL	HORIZONTAL DIAPHRAGMS	VERTICAL DIAPHRAGMS
	Maximum Span-Width Ratios	Maximum Height-Width Ratios
1. Diagonal sheathing, conventional	3:1	2:1
2. Diagonal sheathing, special	4:1	3 <sup>1</sup> / <sub>2</sub> :1
3. Wood structural panels and particleboard, nailed all edges	4:1	3 <sup>1</sup> / <sub>2</sub> :1
4. Wood structural panels and particleboard, blocking omitted at intermediate joints	4:1	2:1

<sup>2</sup>Framing at adjoining panel edges shall be 3-inch (76 mm) nominal or wider and nails shall be staggered where nails are spaced 2 inches (51 mm) or 2<sup>1</sup>/<sub>2</sub> inches (64 mm) on center.

<sup>3</sup>Framing at adjoining panel edges shall be 3-inch (76 mm) nominal or wider and nails shall be staggered where 10d nails having penetration into framing of more than 1<sup>5</sup>/<sub>8</sub> inches (41 mm) are spaced 3 inches (76 mm) or less on center.

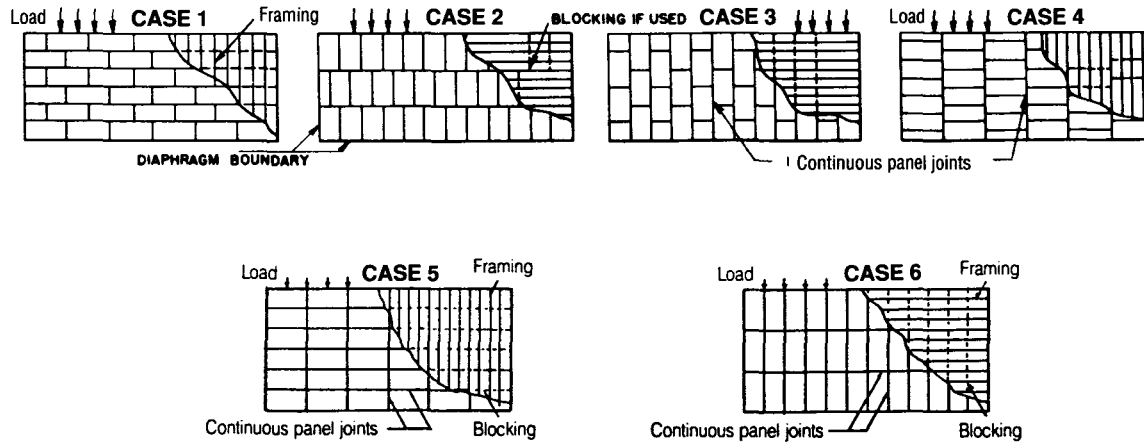

**NOTE:** Framing may be oriented in either direction for diaphragms, provided sheathing is properly designed for vertical loading.

TABLE 23-I-J-1—ALLOWABLE SHEAR IN POUNDS PER FOOT FOR HORIZONTAL WOOD STRUCTURAL PANEL  
DIAPHRAGMS WITH FRAMING OF DOUGLAS FIR-LARCH OR SOUTHERN PINE<sup>1</sup>

PANEL GRADE	COMMON NAIL SIZE	MINIMUM NAIL PENETRATION IN FRAMING (Inches)	MINIMUM NOMINAL PANEL THICKNESS (Inches)	MINIMUM NOMINAL WIDTH OF FRAMING MEMBER (Inches)	BLOCKED DIAPHRAGMS				UNBLOCKED DIAPHRAGMS			
					Nail spacing (in.) at diaphragm boundaries (all cases), at continuous panel edges parallel to load (Cases 3 and 4) and at all panel edges (Cases 5 and 6)				Nails spaced 6" (152 mm) max. at supported edges			
					× 25.4 for mm				Case 1 (No unblocked edges or continuous joints parallel to load)		All other configurations (Cases 2, 3, 4, 5 and 6)	
					6	4	2 1/2 <sup>2</sup>	2 <sup>2</sup>				
					Nail spacing (in.) at other panel edges				Case 1 (No unblocked edges or continuous joints parallel to load)		All other configurations (Cases 2, 3, 4, 5 and 6)	
					× 25.4 for mm							
					6		3					
					× 0.0146 for N/mm							
Structural I	6d	1 1/4	5/16	2 3	185 210	250 280	375 420	420 475	165 185	125 140		
	8d	1 1/2	3/8	2 3	270 300	360 400	530 600	600 675	240 265	180 200		
	10d <sup>3</sup>	1 5/8	15/32	2 3	320 360	425 480	640 720	730 820	285 320	215 240		
C-D, C-C, Sheathing, and other grades covered in U.B.C. Standard 23-2 or 23-3	6d	1 1/4	5/16	2 3	170 190	225 250	335 380	380 430	150 170	110 125		
			3/8	2 3	185 210	250 280	375 420	420 475	165 185	125 140		
	8d	1 1/2	3/8	2 3	240 270	320 360	480 540	545 610	215 240	160 180		
			7/16	2 3	255 285	340 380	505 570	575 645	230 255	170 190		
			15/32	2 3	270 300	360 400	530 600	600 675	240 265	180 200		
	10d <sup>3</sup>	1 5/8	15/32	2 3	290 325	385 430	575 650	655 735	255 290	190 215		
			19/32	2 3	320 360	425 480	640 720	730 820	285 320	215 240		

<sup>1</sup>These values are for short-time loads due to wind or earthquake and must be reduced 25 percent for normal loading. Space nails 12 inches (305 mm) on center along intermediate framing members.

Allowable shear values for nails in framing members of other species set forth in Table 23-III-FF of Division III shall be calculated for all other grades by multiplying the shear capacities for nails in Structural I by the following factors: 0.82 for species with specific gravity greater than or equal to 0.42 but less than 0.49, and 0.65 for species with a specific gravity less than 0.42.

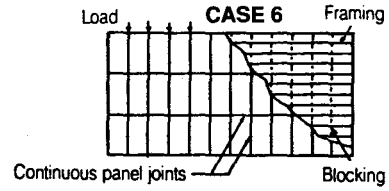
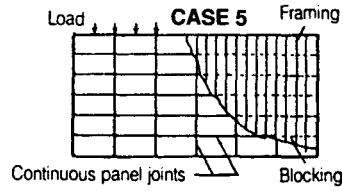
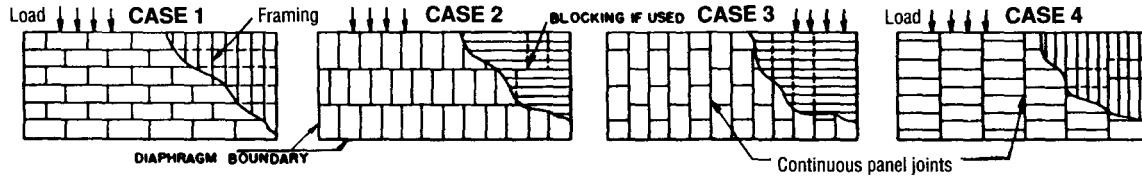

**NOTE:** Framing may be oriented in either direction for diaphragms, provided sheathing is properly designed for vertical loading.

**TABLE 23-I-J-2—ALLOWABLE SHEAR IN POUNDS PER FOOT FOR HORIZONTAL PARTICLEBOARD DIAPHRAGMS  
WITH FRAMING OF DOUGLAS FIR-LARCH OR SOUTHERN PINE<sup>1</sup>**

PANEL GRADE	COMMON NAIL SIZE	MINIMUM NAIL PENETRATION IN FRAMING (inches)	MINIMUM NOMINAL PANEL THICKNESS (inches)	MINIMUM NOMINAL WIDTH OF FRAMING MEMBER (inches)	BLOCKED DIAPHRAGMS				UNBLOCKED DIAPHRAGMS					
					Nail spacing (in.) at diaphragm boundaries (all cases), at continuous panel edges parallel to load (Cases 3 and 4) and at all panel edges (Cases 5 and 6)				Nails spaced 6" (152 mm) max. at supported edges					
					× 25.4 for mm				6	4	2 1/2 <sup>2</sup>	2 <sup>2</sup>	Case 1 (No unblocked edges or continuous joints parallel to load)	All other configurations (Cases 2, 3, 4, 5 and 6)
					Nail spacing (in.) at other plywood panel edges									
					× 25.4 for mm				6	6	4	3		
					× 0.0146 for N/mm									
2-M-W	6d	1 1/4	5/16	2	170	225	335	380	150	110				
				3	190	250	380	430	170	125				
	8d	1 1/2	3/8	2	185	250	375	420	165	125				
				3	210	280	420	475	185	140				
			3/8	2	240	320	480	545	215	160				
				3	270	360	540	610	240	180				
			7/16	2	255	340	505	575	230	170				
				3	285	380	570	645	255	190				
	10d <sup>3</sup>	1 5/8	1/2	2	270	360	530	600	240	180				
				3	300	400	600	675	265	200				
2-M-3	10d <sup>3</sup>	1 5/8	1/2	2	290	385	575	655	255	190				
				3	325	430	650	735	290	215				
		5/8	2	320	425	640	730	285	215					
			3	360	480	720	820	320	240					
		3/4	2	320	425	640	730	285	215					
			3	360	480	720	820	320	240					

<sup>1</sup>These values are for short time loads due to wind or earthquake and must be reduced 25 percent for normal loading. Space nails 12 inches (305 mm) on center along intermediate framing members.

Allowable shear values for nails in framing members of other species set forth in Table 23-III-J of Division III shall be calculated for all grades by multiplying the values for nails by the following factors: Group III, 0.82 and Group IV, 0.65.

<sup>2</sup>Framing at adjoining panel edges shall be 3-inch (76 mm) nominal or wider and nails shall be staggered where nails are spaced 2 inches (51 mm) or 2 1/2 inches (64 mm) on center.

<sup>3</sup>Framing at adjoining panel edges shall be 3-inch (76 mm) nominal or wider and nails shall be staggered where 10d nails having penetration into framing of more than 1 5/8 inches (41 mm) are spaced 3 inches (76 mm) or less on center.

**TABLE 23-I-K-1—ALLOWABLE SHEAR FOR WIND OR SEISMIC FORCES IN POUNDS PER FOOT FOR WOOD STRUCTURAL PANEL SHEAR WALLS WITH FRAMING OF DOUGLAS FIR-LARCH OR SOUTHERN PINE<sup>1,2</sup>**

PANEL GRADE	MINIMUM NOMINAL PANEL THICKNESS (inches) × 25.4 for mm	MINIMUM NAIL PENETRATION IN FRAMING (inches)	PANELS APPLIED DIRECTLY TO FRAMING				PANELS APPLIED OVER 1/2-INCH (13 mm) OR 5/8-INCH (16 mm) GYPSUM SHEATHING					
			Nail Size (Common or Galvanized Box)	Nail Spacing at Panel Edges (in.)				Nail Size (Common or Galvanized Box)	Nail Spacing at Panel Edges (in.)			
				× 25.4 for mm					× 25.4 for mm			
				6	4	3	2 <sup>3</sup>		6	4	3	2 <sup>3</sup>
			× 0.0146 for N/mm				× 0.0146 for N/mm					
Structural I	5/16	1 1/4	6d	200	300	390	510	8d	200	300	390	510
	3/8	1 1/2	8d	230 <sup>4</sup>	360 <sup>4</sup>	460 <sup>4</sup>	610 <sup>4</sup>	10d <sup>5</sup>	280	430	550	730
	7/16			255 <sup>4</sup>	395 <sup>4</sup>	505 <sup>4</sup>	670 <sup>4</sup>					
	15/32			280	430	550	730					
15/32	1 5/8	10d <sup>5</sup>	340	510	665	870	—	—	—	—		
C-D, C-C Sheathing, plywood panel siding and other grades covered in U.B.C. Standard 23-2 or 23-3	5/16	1 1/4	6d	180	270	350	450	8d	180	270	350	450
	3/8	1 1/2	8d	200	300	390	510	10d <sup>5</sup>	260	380	490	640
	3/8			220 <sup>4</sup>	320 <sup>4</sup>	410 <sup>4</sup>	530 <sup>4</sup>					
	7/16			240 <sup>4</sup>	350 <sup>4</sup>	450 <sup>4</sup>	585 <sup>4</sup>					
	15/32	1 5/8	10d <sup>5</sup>	260	380	490	640	—	—	—	—	
	19/32			310	460	600	770					
				340	510	665	870					
Plywood panel siding in grades covered in U.B.C. Standard 23-2	5/16	1 1/4	6d	140	210	275	360	8d	140	210	275	360
	3/8	1 1/2	8d	160	240	310	410	10d <sup>5</sup>	160	240	310	410

<sup>1</sup>All panel edges backed with 2-inch (51 mm) nominal or wider framing. Panels installed either horizontally or vertically. Space nails at 6 inches (152 mm) on center along intermediate framing members for 3/8-inch (9.5 mm) and 7/16-inch (11 mm) panels installed on studs spaced 24 inches (610 mm) on center and 12 inches (305 mm) on center for other conditions and panel thicknesses. These values are for short-time loads due to wind or earthquake and must be reduced 25 percent for normal loading.

Allowable shear values for nails in framing members of other species set forth in Table 23-III-FF of Division III shall be calculated for all other grades by multiplying the shear capacities for nails in Structural I by the following factors: 0.82 for species with specific gravity greater than or equal to 0.42 but less than 0.49, and 0.65 for species with a specific gravity less than 0.42.

<sup>2</sup>Where panels are applied on both faces of a wall and nail spacing is less than 6 inches (152 mm) on center on either side, panel joints shall be offset to fall on different framing members or framing shall be 3-inch (76 mm) nominal or thicker and nails on each side shall be staggered.

<sup>3</sup>Framing at adjoining panel edges shall be 3-inch (76 mm) nominal or wider and nails shall be staggered where nails are spaced 2 inches (51 mm) on center.

<sup>4</sup>The values for 3/8-inch (9.5 mm) and 7/16-inch (11 mm) panels applied direct to framing may be increased to values shown for 15/32-inch (12 mm) panels, provided studs are spaced a maximum of 16 inches (406 mm) on center or panels are applied with long dimension across studs.  
<sup>5</sup>Framing at adjoining panel edges shall be 3-inch (76 mm) nominal or wider and nails shall be staggered where 10d nails having penetration into framing of more than 15/8 inches (41 mm) are spaced 3 inches (76 mm) or less on center.

**TABLE 23-I-K-2—ALLOWABLE SHEAR FOR WIND OR SEISMIC FORCES IN POUNDS PER FOOT FOR PARTICLEBOARD SHEAR WALLS WITH FRAMING OF DOUGLAS FIR-LARCH OR SOUTHERN PINE<sup>1, 2</sup>**

PANEL GRADE	MINIMUM NOMINAL PANEL THICKNESS (inches) × 25.4 for mm	MINIMUM NAIL PENETRATION IN FRAMING (inches)	PANELS APPLIED DIRECTLY TO FRAMING				PANEL APPLIED OVER 1/2-INCH (13 mm) GYPSUM SHEATHING					
			Nail Size (Common or Galvanized Box)	Nail Spacing at Panel Edges (inches)				Nail Size (Common or Galvanized Box)	Nail Spacing at Plywood Panel Edges (inches)			
				× 25.4 for mm					× 25.4 for mm			
				6	4	3	2 <sup>3</sup>		6	4	3	2 <sup>3</sup>
× 0.0146 for N/mm				× 0.0146 for N/mm								
2-M-W	5/16	1 1/4	6d	180	270	350	450	8d	180	270	350	450
	3/8			200	300	390	510		200	300	390	510
	3/8	1 1/2	8d	220 <sup>4</sup>	320 <sup>4</sup>	410 <sup>4</sup>	530 <sup>4</sup>	10d <sup>5</sup>	260	380	490	640
	7/16			240 <sup>4</sup>	350 <sup>4</sup>	450 <sup>4</sup>	585 <sup>4</sup>					
	1/2			260	380	490	640					
	1/2	1 5/8	10d <sup>5</sup>	310	460	600	770	—	—	—	—	
	5/8			340	510	665	870	—	—	—	—	

<sup>1</sup>All panel edges backed with 2-inch (51 mm) nominal or wider framing. Plywood installed either horizontally or vertically. Space nails at 6 inches (152 mm) on center along intermediate framing members for 3/8-inch (9.5 mm) panel installed with the long dimension parallel to studs spaced 24 inches (610 mm) on center and 12 inches (305 mm) on center for other conditions and panel thicknesses. These values are for short-time loads due to wind or earthquake and must be reduced 25 percent for normal loading.

Allowable shear values for nails in framing members of other species set forth in Table 23-III-J of Division III shall be calculated for all grades by multiplying the values for common and galvanized box nails by the following factors: Group III, 0.82 and Group IV, 0.65.

<sup>2</sup>Where particleboard is applied on both faces of a wall and nail spacing is less than 6 inches (152 mm) on center on either side, panel joints shall be offset to fall on different framing members, or framing shall be 3-inch (76 mm) nominal or thicker and nails on each side shall be staggered.

<sup>3</sup>Framing at adjoining panel edges shall be 3-inch (76 mm) nominal or wider and nails shall be staggered where nails are spaced 2 inches (51 mm) on center.

<sup>4</sup>The allowable shear values may be increased to the values shown for 1/2-inch-thick (13 mm) sheathing with the same nailing, provided:

- 4.1 The studs are spaced a maximum of 16 inches (406 mm) on center, or
- 4.2 The panels are applied with the long dimension perpendicular to studs.

<sup>5</sup>Framing at adjoining panel edges shall be 3-inch (76 mm) nominal or wider and nails shall be staggered where 10d nails having penetration into framing of more than 15/8 inches (41 mm) are spaced 3 inches (76 mm) or less on center.

**TABLE 23-I-L—WOOD SHINGLE AND SHAKE SIDE WALL EXPOSURES**

SHINGLE OR SHAKE  Length and Type	MAXIMUM WEATHER EXPOSURES (Inches)			
	× 25.4 for mm			
	Single-Coursing		Double-Coursing	
	No. 1	No. 2	No. 1	No. 2
1. 16-inch (405 mm) shingles	7 <sup>1</sup> / <sub>2</sub>	7 <sup>1</sup> / <sub>2</sub>	12	10
2. 18-inch (455 mm) shingles	8 <sup>1</sup> / <sub>2</sub>	8 <sup>1</sup> / <sub>2</sub>	14	11
3. 24-inch (610 mm) shingles	11 <sup>1</sup> / <sub>2</sub>	11 <sup>1</sup> / <sub>2</sub>	16	14
4. 18-inch (455 mm) resawn shakes	8 <sup>1</sup> / <sub>2</sub>	—	14	—
5. 18-inch (455 mm) straight-split shakes	8 <sup>1</sup> / <sub>2</sub>	—	16	—
6. 24-inch (610 mm) resawn shakes	11 <sup>1</sup> / <sub>2</sub>	—	20	—

**TABLE 23-I-M-1—EXPOSED PLYWOOD PANEL SIDING**

MINIMUM THICKNESS <sup>1</sup> (Inch) × 25.4 for mm	MINIMUM NUMBER OF PLYS	STUD SPACING (Inches) PLYWOOD SIDING APPLIED DIRECTLY TO STUDS OR OVER SHEATHING
		× 25.4 for mm
3/8	3	16 <sup>2</sup>
1/2	4	24

<sup>1</sup>Thickness of grooved panels is measured at bottom of grooves.

<sup>2</sup>May be 24 inches (610 mm) if plywood siding applied with face grain perpendicular to studs or over one of the following: (1) 1-inch (25 mm) board sheathing, (2) 7/16-inch (11 mm) wood structural panel sheathing or (3) 3/8-inch (9.5 mm) wood structural panel sheathing with strength axis (which is the long direction of the panel unless otherwise marked) of sheathing perpendicular to studs.

**TABLE 23-I-M-2—ALLOWABLE SPANS FOR EXPOSED PARTICLEBOARD PANEL SIDING**

GRADE	STUD SPACING (Inches) × 25.4 for mm	MINIMUM THICKNESS (Inches)		
		× 25.4 for mm		
		Siding		Exterior Ceilings and Soffits
		Direct to Studs	Continuous Support	Direct to Supports
2-M-W	16	3/8	5/16	5/16
	24	1/2	5/16	3/8
2-M-1	16	5/8	3/8	—
2-M-2	24	3/4	3/8	—
2-M-3				

**TABLE 23-I-N-1—WOOD STRUCTURAL PANEL WALL SHEATHING<sup>1</sup>  
(Not exposed to the weather, strength axis parallel or perpendicular to studs)**

MINIMUM THICKNESS (Inch) × 25.4 for mm	PANEL SPAN RATING	STUD SPACING (Inches)		
		× 25.4 for mm		
		Siding Nailed to Studs	Sheathing under Coverings Specified in Section 2326.11.3	
Sheathing Parallel to Studs	Sheathing Perpendicular to Studs			
1. 5/16	12/0, 16/0, 20/0 Wall—16 o.c.	16	—	16
2. 3/8, 15/32, 1/2	16/0, 20/0, 24/0, 32/16 Wall—24 o.c.	24	16	24
3. 7/16, 15/32, 1/2	24/0, 24/16, 32/16 Wall—24 o.c.	24	24 <sup>2</sup>	24

<sup>1</sup>In reference to Section 2326.11.3, blocking of horizontal joints is not required.

<sup>2</sup>Plywood shall consist of four or more plies.

**TABLE 23-I-N-2—ALLOWABLE SPANS FOR PARTICLEBOARD WALL SHEATHING<sup>1</sup>**  
 (Not exposed to the weather, long dimension of the panel parallel or perpendicular to studs)

GRADE	THICKNESS (inch)	STUD SPACING (inches)	
		× 25.4 for mm	
		Siding Nailed to Studs	Sheathing under Coverings Specified in Section 2326.11.3 Parallel or Perpendicular to Studs
		× 25.4 for mm	
2-M-W	5/16	16	—
	3/8	24	16
	7/16	24	14
2-M-1	3/8	16	—
2-M-2			
2-M-3			

<sup>1</sup>In reference to Section 2326.11.3, blocking of horizontal joints is not required.

**TABLE 23-I-O—HARDBOARD SIDING**

SIDING	MINIMAL NOMINAL THICKNESS (inch)	FRAMING (2" x 4") MAXIMUM SPACING	NAIL SIZE <sup>1,2</sup>	NAIL SPACING	
				General	Bracing Panels <sup>3</sup>
× 25.4 for mm					
<b>1. LAP SIDING</b>					
Direct to studs	3/8	16" o.c.	8d	16" o.c.	Not applicable
Over sheathing					
<b>2. SQUARE EDGE PANEL SIDING</b>					
Direct to studs	3/8	24" o.c.	6d	6" o.c. edges; 12" o.c. at intermed. supports	4" o.c. edges; 8" o.c. intermed. supports
Over sheathing					
<b>3. SHIPLAP EDGE PANEL SIDING</b>					
Direct to studs	3/8	16" o.c.	6d	6" o.c. edges; 12" o.c. at intermed. supports	4" o.c. edges; 8" o.c. intermed. supports
Over sheathing					

<sup>1</sup>Nails shall be corrosion resistant in accordance with Division III.

<sup>2</sup>Minimum acceptable nail dimensions (inches).

	Panel Siding (inch)	Lap Siding (inch)
	× 25.4 for mm	
Shank diameter	.092	.099
Head diameter	.225	.240

<sup>3</sup>When used to comply with Section 2326.11.3.

**TABLE 23-I-P—ALLOWABLE SHEARS FOR WIND OR SEISMIC LOADING ON VERTICAL DIAPHRAGMS OF FIBERBOARD SHEATHING BOARD CONSTRUCTION FOR TYPE V CONSTRUCTION ONLY<sup>1</sup>**

SIZE AND APPLICATION	NAIL SIZE	SHEAR VALUE IN POUNDS PER FOOT (N/mm) 3-INCH (76 mm) NAIL SPACING AROUND PERIMETER AND 6-INCH (152 mm) AT INTERMEDIATE POINTS
		× 1.46 for N/mm
1. 1/2" x 4' x 8' (13 x 1219 x 2438 mm)	No. 11 gage galvanized roofing nail 1 1/2" (38 mm) long, 7/16" (11 mm) head	125 <sup>2</sup>
2. 25/32" x 4' x 8' (20 x 1219 x 2438 mm)	No. 11 gage galvanized roofing nail 1 3/4" (44 mm) long, 7/16" (11 mm) head	175

<sup>1</sup>Fiberboard sheathing diaphragms shall not be used to brace concrete or masonry walls.

<sup>2</sup>The shear value may be 175 (778 N) for 1/2-inch x 4-foot x 8-foot (13 x 1219 x 2438 mm) fiberboard nail-base sheathing.

**TABLE 23-I-Q—NAILING SCHEDULE**

CONNECTION	NAILING <sup>1</sup>
1. Joist to sill or girder, toenail	3-8d
2. Bridging to joist, toenail each end	2-8d
3. 1" x 6" (25 mm x 152 mm) subfloor or less to each joist, face nail	2-8d
4. Wider than 1" x 6" (25 mm x 152 mm) subfloor to each joist, face nail	3-8d
5. 2" (51 mm) subfloor to joist or girder, blind and face nail	2-16d
6. Sole plate to joist or blocking, typical face nail Sole plate to joist or blocking, at braced wall panels	16d at 16" (406 mm) o.c. 3-16d per 16" (406 mm)
7. Top plate to stud, end nail	2-16d
8. Stud to sole plate	4-8d, toenail or 2-16d, end nail
9. Double studs, face nail	16d at 24" (610 mm) o.c.
10. Doubled top plates, typical face nail Double top plates, lap splice	16d at 16" (406 mm) o.c. 8-16d
11. Blocking between joists or rafters to top plate, toenail	3-8d
12. Rim joist to top plate, toenail	8d at 6" (152 mm) o.c.
13. Top plates, laps and intersections, face nail	2-16d
14. Continuous header, two pieces	16d at 16" (406 mm) o.c. along each edge
15. Ceiling joists to plate, toenail	3-8d
16. Continuous header to stud, toenail	4-8d
17. Ceiling joists, laps over partitions, face nail	3-16d
18. Ceiling joists to parallel rafters, face nail	3-16d
19. Rafter to plate, toenail	3-8d
20. 1" (25 mm) brace to each stud and plate, face nail	2-8d
21. 1" x 8" (25 mm x 203 mm) sheathing or less to each bearing, face nail	2-8d
22. Wider than 1" x 8" (25 mm x 203 mm) sheathing to each bearing, face nail	3-8d
23. Built-up corner studs	16d at 24" (610 mm) o.c.
24. Built-up girder and beams	20d at 32" (813 mm) o.c. at top and bottom and staggered 2-20d at ends and at each splice
25. 2" (51 mm) planks	2-16d at each bearing

(Continued)

TABLE 23-I-Q—NAILING SCHEDULE—(Continued)

CONNECTION	NAILING <sup>1</sup>
26. Wood structural panels and particleboard: <sup>2</sup> Subfloor, roof and wall sheathing (to framing): (1 inch = 25.4 mm) $\frac{1}{2}$ " and less $\frac{19}{32}$ "- $\frac{3}{4}$ " $\frac{7}{8}$ "-1" $1\frac{1}{8}$ "- $1\frac{1}{4}$ " Combination subfloor-underlayment (to framing): (1 inch = 25.4 mm) $\frac{3}{4}$ " and less $\frac{7}{8}$ "-1" $1\frac{1}{8}$ "- $1\frac{1}{4}$ "	6d <sup>3</sup> 8d <sup>4</sup> or 6d <sup>5</sup> 8d <sup>3</sup> 10d <sup>4</sup> or 8d <sup>5</sup> 6d <sup>5</sup> 8d <sup>5</sup> 10d <sup>4</sup> or 8d <sup>5</sup>
27. Panel siding (to framing): $\frac{1}{2}$ " (13 mm) or less $\frac{5}{8}$ " (16 mm)	6d <sup>6</sup> 8d <sup>6</sup>
28. Fiberboard sheathing: <sup>7</sup> $\frac{1}{2}$ " (13 mm) $2\frac{5}{32}$ " (20 mm)	No. 11 ga. <sup>8</sup> 6d <sup>4</sup> No. 16 ga. <sup>9</sup> No. 11 ga. <sup>8</sup> 8d <sup>4</sup> No. 16 ga. <sup>9</sup>
29. Interior paneling $\frac{1}{4}$ " (6.4 mm) $\frac{3}{8}$ " (9.5 mm)	4d <sup>10</sup> 6d <sup>11</sup>

- <sup>1</sup>Common or box nails may be used except where otherwise stated.
- <sup>2</sup>Nails spaced at 6 inches (152 mm) on center at edges, 12 inches (305 mm) at intermediate supports except 6 inches (152 mm) at all supports where spans are 48 inches (1219 mm) or more. For nailing of wood structural panel and particleboard diaphragms and shear walls, refer to Section 2314.3. Nails for wall sheathing may be common, box or casing.
- <sup>3</sup>Common or deformed shank.
- <sup>4</sup>Common.
- <sup>5</sup>Deformed shank.
- <sup>6</sup>Corrosion-resistant siding or casing nails conforming to the requirements of Section 2325.1.
- <sup>7</sup>Fasteners spaced 3 inches (76 mm) on center at exterior edges and 6 inches (152 mm) on center at intermediate supports.
- <sup>8</sup>Corrosion-resistant roofing nails with  $\frac{7}{16}$ -inch-diameter (11 mm) head and  $1\frac{1}{2}$ -inch (38 mm) length for  $\frac{1}{2}$ -inch (13 mm) sheathing and  $1\frac{3}{4}$ -inch (44 mm) length for  $2\frac{5}{32}$ -inch (20 mm) sheathing conforming to the requirements of Section 2325.1.
- <sup>9</sup>Corrosion-resistant staples with nominal  $\frac{7}{16}$ -inch (11 mm) crown and  $1\frac{1}{8}$ -inch (29 mm) length for  $\frac{1}{2}$ -inch (13 mm) sheathing and  $1\frac{1}{2}$ -inch (38 mm) length for  $2\frac{5}{32}$ -inch (20 mm) sheathing conforming to the requirements of Section 2325.1.
- <sup>10</sup>Panel supports at 16 inches (406 mm) [20 inches (508 mm) if strength axis in the long direction of the panel, unless otherwise marked]. Casing or finish nails spaced 6 inches (152 mm) on panel edges, 12 inches (305 mm) at intermediate supports.
- <sup>11</sup>Panel supports at 24 inches (610 mm). Casing or finish nails spaced 6 inches (152 mm) on panel edges, 12 inches (305 mm) at intermediate supports.

TABLE 23-I-R-1—ALLOWABLE SPANS FOR LUMBER FLOOR AND ROOF SHEATHING<sup>1, 2</sup>

SPAN (Inches)	MINIMUM NET THICKNESS (Inches) OF LUMBER PLACED			
	Perpendicular to Supports		Diagonally to Supports	
	× 25.4 for mm			
× 25.4 for mm	Surfaced Dry <sup>3</sup>	Surfaced Unseasoned	Surfaced Dry <sup>3</sup>	Surfaced Unseasoned
<b>Floors</b>				
1. 24	$\frac{3}{4}$	$\frac{25}{32}$	$\frac{3}{4}$	$\frac{25}{32}$
2. 16	$\frac{5}{8}$	$\frac{11}{16}$	$\frac{5}{8}$	$\frac{11}{16}$
<b>Roofs</b>				
3. 24	$\frac{5}{8}$	$\frac{11}{16}$	$\frac{3}{4}$	$\frac{25}{32}$

- <sup>1</sup>Installation details shall conform to Sections 2326.9.1 and 2326.12.8 for floor and roof sheathing, respectively.
- <sup>2</sup>Floor or roof sheathing conforming with this table shall be deemed to meet the design criteria of Section 2322.
- <sup>3</sup>Maximum 19 percent moisture content.

**TABLE 23-I-R-2—SHEATHING LUMBER SHALL MEET THE FOLLOWING  
MINIMUM GRADE REQUIREMENTS: BOARD GRADE**

SOLID FLOOR OR ROOF SHEATHING	SPACED ROOF SHEATHING	GRADING RULES
1. Utility	Standard	NLGA, WCLIB, WWPA
2. 4 common or utility	3 common or standard	NLGA, WCLIB, WWPA, NHPMA or NELMA
3. No. 3	No. 2	SPIB
4. Merchantable	Construction common	RIS

**TABLE 23-I-R-3—SIZE, HEIGHT AND SPACING OF WOOD STUDS**

STUD SIZE (Inches)	BEARING WALLS				NONBEARING WALLS	
	Laterally Unsupported Stud Height <sup>1</sup> (feet)	Supporting Roof and Ceiling Only	Supporting One Floor, Roof and Ceiling	Supporting Two Floors, Roof and Ceiling	Laterally Unsupported Stud Height <sup>1</sup> (feet)	Spacing (Inches)
× 25.4 for mm	× 304.8 for mm	× 25.4 for mm			× 304.8 for mm	× 25.4 for mm
1. 2 x 3 <sup>2</sup>	—	—	—	—	10	16
2. 2 x 4	10	24	16	—	14	24
3. 3 x 4	10	24	24	16	14	24
4. 2 x 5	10	24	24	—	16	24
5. 2 x 6	10	24	24	16	20	24

<sup>1</sup>Listed heights are distances between points of lateral support placed perpendicular to the plane of the wall. Increases in unsupported height are permitted where justified by an analysis.

<sup>2</sup>Shall not be used in exterior walls.

**TABLE 23-I-S-1—ALLOWABLE SPANS AND LOADS FOR WOOD STRUCTURAL PANEL SHEATHING AND SINGLE-FLOOR GRADES CONTINUOUS OVER TWO OR MORE SPANS WITH STRENGTH AXIS PERPENDICULAR TO SUPPORTS<sup>1,2</sup>**

SHEATHING GRADES		ROOF <sup>3</sup>				FLOOR <sup>4</sup>
Panel Span Rating	Panel Thickness (inches)	Maximum Span (inches)		Load <sup>5</sup> (pounds per square foot)		Maximum Span (inches)
		× 25.4 for mm		× 0.0479 for kN/m <sup>2</sup>		
Roof/Floor Span	× 25.4 for mm	With Edge Support <sup>6</sup>	Without Edge Support	Total Load	Live Load	× 25.4 for mm
12/0	5/16	12	12	40	30	0
16/0	5/16, 3/8	16	16	40	30	0
20/0	5/16, 3/8	20	20	40	30	0
24/0	3/8, 7/16, 1/2	24	20 <sup>7</sup>	40	30	0
24/16	1/16, 1/2, 5/8	24	24	50	40	16
32/16	15/32, 1/2, 5/8	32	28	40	30	16 <sup>8</sup>
40/20	19/32, 5/8, 3/4, 7/8	40	32	40	30	20 <sup>8,9</sup>
48/24	23/32, 3/4, 7/8	48	36	45	35	24
54/32	7/8, 1	54	40	45	35	32
60/48	7/8, 1, 1 1/8	60	48	45	35	48
SINGLE-FLOOR GRADES		ROOF <sup>3</sup>				FLOOR <sup>4</sup>
Panel Span Rating (inches)	Panel Thickness (inches)	Maximum Span (inches)		Load <sup>5</sup> (pounds per square foot)		Maximum Span (inches)
		× 25.4 for mm		× 0.0479 for kN/m <sup>2</sup>		
× 25.4 for mm	× 25.4 for mm	With Edge Support <sup>6</sup>	Without Edge Support	Total Load	Live Load	× 25.4 for mm
16 oc	1/2, 19/32, 5/8	24	24	50	40	16 <sup>8</sup>
20 oc	19/32, 5/8, 3/4	32	32	40	30	20 <sup>8,9</sup>
24 oc	23/32, 3/4	48	36	35	25	24
32 oc	7/8, 1	48	40	50	40	32
48 oc	1 3/32, 1 1/8	60	48	50	50	48

<sup>1</sup>Applies to panels 24 inches (610 mm) or wider.

<sup>2</sup>Floor and roof sheathing conforming with this table shall be deemed to meet the design criteria of Section 2321.

<sup>3</sup>Uniform load deflection limitations 1/180 of span under live load plus dead load, 1/240 under live load only.

<sup>4</sup>Panel edges shall have approved tongue-and-groove joints or shall be supported with blocking unless 1/4-inch (6.4 mm) minimum thickness underlayment or 1 1/2 inches (38 mm) of approved cellular or lightweight concrete is placed over the subfloor, or finish floor is 3/4-inch (19 mm) wood strip. Allowable uniform load based on deflection of 1/360 of span is 100 pounds per square foot (psf) (4.79 kN/m<sup>2</sup>) except the span rating of 48 inches on center is based on a total load of 65 psf (3.11 kN/m).

<sup>5</sup>Allowable load at maximum span.

<sup>6</sup>Tongue-and-groove edges, panel edge clips [one midway between each support, except two equally spaced between supports 48 inches (1219 mm) on center], lumber blocking, or other. Only lumber blocking shall satisfy blocked diaphragms requirements.

<sup>7</sup>For 1/2-inch (13 mm) panel, maximum span shall be 24 inches (610 mm).

<sup>8</sup>May be 24 inches (610 mm) on center where 3/4-inch (19 mm) wood strip flooring is installed at right angles to joist.

<sup>9</sup>May be 24 inches (610 mm) on center for floors where 1 1/2 inches (38 mm) of cellular or lightweight concrete is applied over the panels.

**TABLE 23-I-S-2—ALLOWABLE LOAD (PSF) FOR WOOD STRUCTURAL PANEL ROOF SHEATHING CONTINUOUS OVER TWO OR MORE SPANS AND STRENGTH AXIS PARALLEL TO SUPPORTS (Plywood structural panels are five-ply, five-layer unless otherwise noted.)<sup>1,2</sup>**

PANEL GRADE	THICKNESS (inch) × 25.4 for mm	MAXIMUM SPAN (inches)	LOAD AT MAXIMUM SPAN (psf)	
			× 0.0479 for kN/m <sup>2</sup>	
			Live	Total
Structural I	7/16	24	20	30
	15/32	24	35 <sup>3</sup>	45 <sup>3</sup>
	1/2	24	40 <sup>3</sup>	50 <sup>3</sup>
	19/32, 5/8	24	70	80
	23/32, 3/4	24	90	100
Other grades covered in U.B.C. Standard 23-2 or 23-3	7/16	16	40	50
	15/32	24	20	25
	1/2	24	25	30
	19/32	24	40 <sup>3</sup>	50 <sup>3</sup>
	5/8	24	45 <sup>3</sup>	55 <sup>3</sup>
	23/32, 3/4	24	60 <sup>3</sup>	65 <sup>3</sup>

<sup>1</sup>Roof sheathing conforming with this table shall be deemed to meet the design criteria of Section 2321.

<sup>2</sup>Uniform load deflection limitations:  $1/180$  of span under live load plus dead load,  $1/240$  under live load only. Edges shall be blocked with lumber or other approved type of edge supports.

<sup>3</sup>For composite and four-ply plywood structural panel, load shall be reduced by 15 pounds per square foot (0.72 kN/m<sup>2</sup>).

**TABLE 23-I-S-3—ALLOWABLE LOADS FOR PARTICLEBOARD ROOF SHEATHING<sup>1, 2, 3</sup>**

GRADE	THICKNESS (inch)	MAXIMUM ON-CENTER SPACING OF SUPPORTS (inches)	LIVE LOAD (pounds per square foot)	TOTAL LOAD (pounds per square foot)
		× 25.4 for mm	× 0.0479 for kN/m <sup>2</sup>	
2-M-W	3/8 <sup>4</sup>	16	45	65
	7/16	16	105	105
	7/16 <sup>4</sup>	24	30	40
	1/2	16	110	150
	1/2	24	40	55

<sup>1</sup>Panels are continuous over two or more spans.

<sup>2</sup>Uniform load deflection limitation:  $1/180$  of the span under live load plus dead load and  $1/240$  of the span under live load only.

<sup>3</sup>Roof sheathing conforming with this table shall be deemed to meet the design criteria of Section 2321.

<sup>4</sup>Edges shall be tongue-and-groove or supported with blocking or edge clips.

**TABLE 23-I-T-1—ALLOWABLE SPAN FOR WOOD STRUCTURAL PANEL COMBINATION SUBFLOOR-UNDERLAYMENT (SINGLE FLOOR)<sup>1,2</sup>**  
**Panels Continuous over Two or More Spans and Strength Axis Perpendicular to Supports**

IDENTIFICATION	MAXIMUM SPACING OF JOISTS (inches)				
	× 25.4 for mm				
	16	20	24	32	48
Species Group <sup>3</sup>	Thickness (inches)				
	× 25.4 for mm				
1	1/2	5/8	3/4	—	—
2, 3	5/8	3/4	7/8	—	—
4	3/4	7/8	1	—	—
Span rating <sup>4</sup>	16 o.c.	20 o.c.	24 o.c.	32 o.c.	48 o.c.

<sup>1</sup>Spans limited to value shown because of possible effects of concentrated loads. Allowable uniform loads based on deflection of  $1/360$  of span is 100 pounds per square foot (psf) (4.79 kN/m<sup>2</sup>), except allowable total uniform load for  $1\frac{1}{8}$ -inch (29 mm) wood structural panels over joists spaced 48 inches (1219 mm) on center is 65 psf (3.11 kN/m<sup>2</sup>). Panel edges shall have approved tongue-and-groove joints or shall be supported with blocking, unless  $1/4$ -inch (6.4 mm) minimum thickness underlayment or  $1\frac{1}{2}$  inches (38 mm) of approved cellular or lightweight concrete is placed over the subfloor, or finish floor is  $3/4$ -inch (19 mm) wood strip.

<sup>2</sup>Floor panels conforming with this table shall be deemed to meet the design criteria of Section 2321.

<sup>3</sup>Applicable to all grades of sanded exterior-type plywood. See U.B.C. Standard 23-2 for plywood species groups.

<sup>4</sup>Applicable to underlayment grade and C-C (plugged) plywood, and single floor grade wood structural panels.

**TABLE 23-I-T-2—ALLOWABLE SPANS FOR PARTICLEBOARD SUBFLOOR AND COMBINED SUBFLOOR-UNDERLAYMENT<sup>1, 2</sup>**

GRADE	THICKNESS (inches) × 25.4 for mm	MAXIMUM SPACING OF SUPPORTS (inches) <sup>3</sup>	
		× 25.4 for mm	
		Subfloor	Combined Subfloor-Underlayment <sup>4,5</sup>
2-M-W	1/2	16	—
	5/8	20	16
	3/4	24	24
2-M-3	3/4	20	20

<sup>1</sup>All panels are continuous over two or more spans.

<sup>2</sup>Floor sheathing conforming with this table shall be deemed to meet the design criteria of Section 2321.

<sup>3</sup>Uniform deflection limitation:  $1/360$  of the span under 100 pounds per square foot (4.79 kN/m<sup>2</sup>) minimum load.

<sup>4</sup>Edges shall have tongue-and-groove joints or shall be supported with blocking. The tongue-and-groove panels are installed with the long dimension perpendicular to supports.

<sup>5</sup>A finish wearing surface is to be applied to the top of the panel.

TABLE 23-I-U—ALLOWABLE SPANS FOR 2-INCH TONGUE-AND-GROOVE DECKING

SPAN <sup>1</sup> (feet)	LIVE LOAD	DEFLECTION LIMIT	<i>f</i>	<i>E</i>
			(psi)	(psi)
× 304.8 for mm	× 0.0479 for kN/m <sup>2</sup>		× 0.00689 for N/mm <sup>2</sup>	
<b>Roofs</b>				
4	20	1/240 1/360	160	170,000 256,000
	30	1/240 1/360	210	256,000 384,000
	40	1/240 1/360	270	340,000 512,000
4.5	20	1/240 1/360	200	242,000 305,000
	30	1/240 1/360	270	363,000 405,000
	40	1/240 1/360	350	484,000 725,000
5.0	20	1/240 1/360	250	332,000 500,000
	30	1/240 1/360	330	495,000 742,000
	40	1/240 1/360	420	660,000 1,000,000
5.5	20	1/240 1/360	300	442,000 660,000
	30	1/240 1/360	400	662,000 998,000
	40	1/240 1/360	500	884,000 1,330,000
6.0	20	1/240 1/360	360	575,000 862,000
	30	1/240 1/360	480	862,000 1,295,000
	40	1/240 1/360	600	1,150,000 1,730,000
6.5	20	1/240 1/360	420	595,000 892,000
	30	1/240 1/360	560	892,000 1,340,000
	40	1/240 1/360	700	1,190,000 1,730,000
7.0	20	1/240 1/360	490	910,000 1,360,000
	30	1/240 1/360	650	1,370,000 2,000,000
	40	1/240 1/360	810	1,820,000 2,725,000

**TABLE 23-I-U—ALLOWABLE SPANS FOR 2-INCH TONGUE-AND-GROOVE  
DECKING—(Continued)**

SPAN <sup>1</sup> (feet)	LIVE LOAD	DEFLECTION LIMIT	$f$	$E$
			(psi)	(psi)
× 304.8 for mm	× 0.0479 for kN/m <sup>2</sup>		× 0.00689 for N/mm <sup>2</sup>	
7.5	20	1/240	560	1,125,000
		1/360		1,685,000
	30	1/240	750	1,685,000
		1/360		2,530,000
	40	1/240	930	2,250,000
		1/360		3,380,000
8.0	20	1/240	640	1,360,000
		1/360		2,040,000
	30	1/240	850	2,040,000
		1/360		3,060,000
<b>Floors</b>				
4	40	1/360	840	1,000,000
4.5			950	1,300,000
5.0			1060	1,600,000

<sup>1</sup>Spans are based on simple beam action with 10 pounds per square foot (0.48 kN/m<sup>2</sup>) dead load and provisions for a 300-pound (1334 N) concentrated load on a 12-inch (305 mm) width of floor decking. Random lay-up permitted in accordance with the provisions of Section 2326.9.3 or 2326.12.9. Lumber thickness assumed at 1½ inches (38 mm), net.

**TABLE 23-I-V-J-1—FLOOR JOISTS WITH L/360 DEFLECTION LIMITS**  
 The allowable bending stress ( $F_b$ ) and modulus of elasticity ( $E$ ) used in this table shall be from Tables 23-I-X-1 and 23-I-X-2 only.

DESIGN CRITERIA: Deflection — For 40 psf (1.92 kN/m <sup>2</sup> ) live load. Limited to span in inches (mm) divided by 360. Strength — Live load of 40 psf (1.92 kN/m <sup>2</sup> ) plus dead load of 10 psf (0.48 kN/m <sup>2</sup> ) determines the required bending design value.																		
Joist Size (in)	Spacing (in)	Modulus of Elasticity, $E$ , in 1,000,000 psi × 0.00689 for N/mm <sup>2</sup>																
		× 25.4 for mm	0.8	0.9	1.0	1.1	1.2	1.3	1.4	1.5	1.6	1.7	1.8	1.9	2.0	2.1	2.2	2.3
2 x 6	12.0	8-6	8-10	9-2	9-6	9-9	10-0	10-3	10-6	10-9	10-11	11-2	11-4	11-7	11-9	11-11	12-1	12-3
	16.0	7-9	8-0	8-4	8-7	8-10	9-1	9-4	9-6	9-9	9-11	10-2	10-4	10-6	10-8	10-10	11-0	11-2
	19.2	7-3	7-7	7-10	8-1	8-4	8-7	8-9	9-0	9-2	9-4	9-6	9-8	9-10	10-0	10-2	10-4	10-6
	24.0	6-9	7-0	7-3	7-6	7-9	7-11	8-2	8-4	8-6	8-8	8-10	9-0	9-2	9-4	9-6	9-7	9-9
2 x 8	12.0	11-3	11-8	12-1	12-6	12-10	13-2	13-6	13-10	14-2	14-5	14-8	15-0	15-3	15-6	15-9	15-11	16-2
	16.0	10-2	10-7	11-0	11-4	11-8	12-0	12-3	12-7	12-10	13-1	13-4	13-7	13-10	14-1	14-3	14-6	14-8
	19.2	9-7	10-0	10-4	10-8	11-0	11-3	11-7	11-10	12-1	12-4	12-7	12-10	13-0	13-3	13-5	13-8	13-10
	24.0	8-11	9-3	9-7	9-11	10-2	10-6	10-9	11-0	11-3	11-5	11-8	11-11	12-1	12-3	12-6	12-8	12-10
2 x 10	12.0	14-4	14-11	15-5	15-11	16-5	16-10	17-3	17-8	18-0	18-5	18-9	19-1	19-5	19-9	20-1	20-4	20-8
	16.0	13-0	13-6	14-0	14-6	14-11	15-3	15-8	16-0	16-5	16-9	17-0	17-4	17-8	17-11	18-3	18-6	18-9
	19.2	12-3	12-9	13-2	13-7	14-0	14-5	14-9	15-1	15-5	15-9	16-0	16-4	16-7	16-11	17-2	17-5	17-8
	24.0	11-4	11-10	12-3	12-8	13-0	13-4	13-8	14-0	14-4	14-7	14-11	15-2	15-5	15-8	15-11	16-2	16-5
2 x 12	12.0	17-5	18-1	18-9	19-4	19-11	20-6	21-0	21-6	21-11	22-5	22-10	23-3	23-7	24-0	24-5	24-9	25-1
	16.0	15-10	16-5	17-0	17-7	18-1	18-7	19-1	19-6	19-11	20-4	20-9	21-1	21-6	21-10	22-2	22-6	22-10
	19.2	14-11	15-6	16-0	16-7	17-0	17-6	17-11	18-4	18-9	19-2	19-6	19-10	20-2	20-6	20-10	21-2	21-6
	24.0	13-10	14-4	14-11	15-4	15-10	16-3	16-8	17-0	17-5	17-9	18-1	18-5	18-9	19-1	19-4	19-8	19-11
$F_b$	12.0	718	777	833	888	941	993	1,043	1,092	1,140	1,187	1,233	1,278	1,323	1,367	1,410	1,452	1,494
	16.0	790	855	917	977	1,036	1,093	1,148	1,202	1,255	1,306	1,357	1,407	1,456	1,504	1,551	1,598	1,644
	19.2	840	909	975	1,039	1,101	1,161	1,220	1,277	1,333	1,388	1,442	1,495	1,547	1,598	1,649	1,698	1,747
	24.0	905	979	1,050	1,119	1,186	1,251	1,314	1,376	1,436	1,496	1,554	1,611	1,667	1,722	1,776	1,829	1,882

**NOTE:** The required bending design value,  $F_b$ , in pounds per square inch (× 0.00689 for N/mm<sup>2</sup>) is shown at the bottom of this table and is applicable to all lumber sizes shown. Spans are shown in feet-inches (1 foot = 304.8 mm, 1 inch = 25.4 mm) and are limited to 26 feet (7925 mm) and less.

**TABLE 23-I-V-J-2—FLOOR JOISTS WITH L/360 DEFLECTION LIMITS**  
 The allowable bending stress ( $F_b$ ) and modulus of elasticity ( $E$ ) used in this table shall be from Tables 23-I-X-1 and 23-I-X-2 only.

DESIGN CRITERIA:																		
Deflection — For 40 (1.92 kN/m <sup>2</sup> ) psf live load.																		
Limited to span in inches (mm) divided by 360.																		
Strength — Live load of 40 psf (1.92 kN/m <sup>2</sup> ) plus dead load of 20 psf (0.96 kN/m <sup>2</sup> ) determines the required bending design value.																		
Joist Size (in)	Spacing (in)	Modulus of Elasticity, $E$ , in 1,000,000 psi																
		× 0.00689 for N/mm <sup>2</sup>																
× 25.4 for mm		0.8	0.9	1.0	1.1	1.2	1.3	1.4	1.5	1.6	1.7	1.8	1.9	2.0	2.1	2.2	2.3	2.4
2 x 6	12.0	8-6	8-10	9-2	9-6	9-9	10-0	10-3	10-6	10-9	10-11	11-2	11-4	11-7	11-9	11-11	12-1	12-3
	16.0	7-9	8-0	8-4	8-7	8-10	9-1	9-4	9-6	9-9	9-11	10-2	10-4	10-6	10-8	10-10	11-0	11-2
	19.2	7-3	7-7	7-10	8-1	8-4	8-7	8-9	9-0	9-2	9-4	9-6	9-8	9-10	10-0	10-2	10-4	10-6
	24.0	6-9	7-0	7-3	7-6	7-9	7-11	8-2	8-4	8-6	8-8	8-10	9-0	9-2	9-4	9-6	9-7	9-9
2 x 8	12.0	11-3	11-8	12-1	12-6	12-10	13-2	13-6	13-10	14-2	14-5	14-8	15-0	15-3	15-6	15-9	15-11	16-2
	16.0	10-2	10-7	11-0	11-4	11-8	12-0	12-3	12-7	12-10	13-1	13-4	13-7	13-10	14-1	14-3	14-6	14-8
	19.2	9-7	10-0	10-4	10-8	11-0	11-3	11-7	11-10	12-1	12-4	12-7	12-10	13-0	13-3	13-5	13-8	13-10
	24.0	8-11	9-3	9-7	9-11	10-2	10-6	10-9	11-0	11-3	11-5	11-8	11-11	12-1	12-3	12-6	12-8	12-10
2 x 10	12.0	14-4	14-11	15-5	15-11	16-5	16-10	17-3	17-8	18-0	18-5	18-9	19-1	19-5	19-9	20-1	20-4	20-8
	16.0	13-0	13-6	14-0	14-6	14-11	15-3	15-8	16-0	16-5	16-9	17-0	17-4	17-8	17-11	18-3	18-6	18-9
	19.2	12-3	12-9	13-2	13-7	14-0	14-5	14-9	15-1	15-5	15-9	16-0	16-4	16-7	16-11	17-2	17-5	17-8
	24.0	11-4	11-10	12-3	12-8	13-0	13-4	13-8	14-0	14-4	14-7	14-11	15-2	15-5	15-8	15-11	16-2	16-5
2 x 12	12.0	17-5	18-1	18-9	19-4	19-11	20-6	21-0	21-6	21-11	22-5	22-10	23-3	23-7	24-0	24-5	24-9	25-1
	16.0	15-10	16-5	17-0	17-7	18-1	18-7	19-1	19-6	19-11	20-4	20-9	21-1	21-6	21-10	22-2	22-6	22-10
	19.2	14-11	15-6	16-0	16-7	17-0	17-6	17-11	18-4	18-9	19-2	19-6	19-10	20-2	20-6	20-10	21-2	21-6
	24.0	13-10	14-4	14-11	15-4	15-10	16-3	16-8	17-0	17-5	17-9	18-1	18-5	18-9	19-1	19-4	19-8	19-11
$F_b$	12.0	862	932	1,000	1,066	1,129	1,191	1,251	1,310	1,368	1,424	1,480	1,534	1,587	1,640	1,692	1,742	1,793
	16.0	949	1,026	1,101	1,173	1,243	1,311	1,377	1,442	1,506	1,568	1,629	1,688	1,747	1,805	1,862	1,918	1,973
	19.2	1,008	1,090	1,170	1,246	1,321	1,393	1,464	1,533	1,600	1,666	1,731	1,794	1,857	1,918	1,978	2,038	2,097
	24.0	1,086	1,174	1,260	1,343	1,423	1,501	1,577	1,651	1,724	1,795	1,864	1,933	2,000	2,066	2,131	2,195	2,258

**NOTE:** The required bending design value,  $F_b$ , in pounds per square inch (× 0.00689 for N/mm<sup>2</sup>) is shown at the bottom of this table and is applicable to all lumber sizes shown. Spans are shown in feet-inches (1 foot = 304.8 mm, 1 inch = 25.4 mm) and are limited to 26 feet (7925 mm) and less.

**TABLE 23-I-V-J-3—CEILING JOISTS WITH L/240 DEFLECTION LIMITS**  
 The allowable bending stress ( $F_b$ ) and modulus of elasticity ( $E$ ) used in this table shall be from Tables 23-I-X-1 and 23-I-X-2 only.

<b>DESIGN CRITERIA:</b>																		
Deflection — For 10 (0.48 kN/m <sup>2</sup> ) psf live load. Limited to span in inches (mm) divided by 240.																		
Strength — Live load of 10 psf (0.48 kN/m <sup>2</sup> ) plus dead load of 5 psf (0.24 kN/m <sup>2</sup> ) determines the required fiber stress value.																		
Joist Size (in)	Spacing (in)	Modulus of Elasticity, $E$ , in 1,000,000 psi																
		× 0.00689 for N/mm <sup>2</sup>																
× 25.4 for mm		0.8	0.9	1.0	1.1	1.2	1.3	1.4	1.5	1.6	1.7	1.8	1.9	2.0	2.1	2.2	2.3	2.4
2 x 4	12.0	9-10	10-3	10-7	10-11	11-3	11-7	11-10	12-2	12-5	12-8	12-11	13-2	13-4	13-7	13-9	14-0	14-2
	16.0	8-11	9-4	9-8	9-11	10-3	10-6	10-9	11-0	11-3	11-6	11-9	11-11	12-2	12-4	12-6	12-9	12-11
	19.2	8-5	8-9	9-1	9-4	9-8	9-11	10-2	10-4	10-7	10-10	11-0	11-3	11-5	11-7	11-9	12-0	12-2
	24.0	7-10	8-1	8-5	8-8	8-11	9-2	9-5	9-8	9-10	10-0	10-3	10-5	10-7	10-9	10-11	11-1	11-3
2 x 6	12.0	15-6	16-1	16-8	17-2	17-8	18-2	18-8	19-1	19-6	19-11	20-3	20-8	21-0	21-4	21-8	22-0	22-4
	16.0	14-1	14-7	15-2	15-7	16-1	16-6	16-11	17-4	17-8	18-1	18-5	18-9	19-1	19-5	19-8	20-0	20-3
	19.2	13-3	13-9	14-3	14-8	15-2	15-7	15-11	16-4	16-8	17-0	17-4	17-8	17-11	18-3	18-6	18-10	19-1
	24.0	12-3	12-9	13-3	13-8	14-1	14-5	14-9	15-2	15-6	15-9	16-1	16-4	16-8	16-11	17-2	17-5	17-8
2 x 8	12.0	20-5	21-2	21-11	22-8	23-4	24-0	24-7	25-2	25-8								
	16.0	18-6	19-3	19-11	20-7	21-2	21-9	22-4	22-10	23-4	23-10	24-3	24-8	25-2	25-7	25-11		
	19.2	17-5	18-1	18-9	19-5	19-11	20-6	21-0	21-6	21-11	22-5	22-10	23-3	23-8	24-0	24-5	24-9	25-2
	24.0	16-2	16-10	17-5	18-0	18-6	19-0	19-6	19-11	20-5	20-10	21-2	21-7	21-11	22-4	22-8	23-0	23-4
2 x 10	12.0	26-0																
	16.0	23-8	24-7	25-5														
	19.2	22-3	23-1	23-11	24-9	25-5												
	24.0	20-8	21-6	22-3	22-11	23-8	24-3	24-10	25-5	26-0								
$F_b$	12.0	711	769	825	880	932	983	1,033	1,082	1,129	1,176	1,221	1,266	1,310	1,354	1,396	1,438	1,480
	16.0	783	847	909	968	1,026	1,082	1,137	1,191	1,243	1,294	1,344	1,394	1,442	1,490	1,537	1,583	1,629
	19.2	832	900	965	1,029	1,090	1,150	1,208	1,265	1,321	1,375	1,429	1,481	1,533	1,583	1,633	1,682	1,731
	24.0	896	969	1,040	1,108	1,174	1,239	1,302	1,363	1,423	1,481	1,539	1,595	1,651	1,706	1,759	1,812	1,864

**NOTE:** The required bending design value,  $F_b$ , in pounds per square inch (× 0.00689 for N/mm<sup>2</sup>) is shown at the bottom of this table and is applicable to all lumber sizes shown. Spans are shown in feet-inches (1 foot = 304.8 mm, 1 inch = 25.4 mm) and are limited to 26 feet (7925 mm) and less.

**TABLE 23-I-V-J-4—CEILING JOISTS WITH L/240 DEFLECTION LIMITS**  
 The allowable bending stress ( $F_b$ ) and modulus of elasticity ( $E$ ) used in this table shall be from Tables 23-I-X-1 and 23-I-X-2 only.

DESIGN CRITERIA:																			
Deflection — For 20 psf (0.96 kN/m <sup>2</sup> ) live load.																			
Limited to span in inches (mm) divided by 240.																			
Strength — Live load of 20 psf (0.96 kN/m <sup>2</sup> ) plus dead load of 10 psf (0.48 kN/m <sup>2</sup> ) determines the required bending design value.																			
Joist Size (in)	Spacing (in)	Modulus of Elasticity, $E$ , in 1,000,000 psi																	
		$\times 0.00689$ for N/mm <sup>2</sup>																	
$\times 25.4$ for mm		0.8	0.9	1.0	1.1	1.2	1.3	1.4	1.5	1.6	1.7	1.8	1.9	2.0	2.1	2.2	2.3	2.4	
2 x 4	12.0	7-10	8-1	8-5	8-8	8-11	9-2	9-5	9-8	9-10	10-0	10-3	10-5	10-7	10-9	10-11	11-1	11-3	
	16.0	7-1	7-5	7-8	7-11	8-1	8-4	8-7	8-9	8-11	9-1	9-4	9-6	9-8	9-9	9-11	10-1	10-3	
	19.2	6-8	6-11	7-2	7-5	7-8	7-10	8-1	8-3	8-5	8-7	8-9	8-11	9-1	9-3	9-4	9-6	9-8	
	24.0	6-2	6-5	6-8	6-11	7-1	7-3	7-6	7-8	7-10	8-0	8-1	8-3	8-5	8-7	8-8	8-10	8-11	
2 x 6	12.0	12-3	12-9	13-3	13-8	14-1	14-5	14-9	15-2	15-6	15-9	16-1	16-4	16-8	16-11	17-2	17-5	17-8	
	16.0	11-2	11-7	12-0	12-5	12-9	13-1	13-5	13-9	14-1	14-4	14-7	14-11	15-2	15-5	15-7	15-10	16-1	
	19.2	10-6	10-11	11-4	11-8	12-0	12-4	12-8	12-11	13-3	13-6	13-9	14-0	14-3	14-6	14-8	14-11	15-2	
	24.0	9-9	10-2	10-6	10-10	11-2	11-5	11-9	12-0	12-3	12-6	12-9	13-0	13-3	13-5	13-8	13-10	14-1	
2 x 8	12.0	16-2	16-10	17-5	18-0	18-6	19-0	19-6	19-11	20-5	20-10	21-2	21-7	21-11	22-4	22-8	23-0	23-4	
	16.0	14-8	15-3	15-10	16-4	16-10	17-3	17-9	18-1	18-6	18-11	19-3	19-7	19-11	20-3	20-7	20-11	21-2	
	19.2	13-10	14-5	14-11	15-5	15-10	16-3	16-8	17-1	17-5	17-9	18-1	18-5	18-9	19-1	19-5	19-8	19-11	
	24.0	12-10	13-4	13-10	14-3	14-8	15-1	15-6	15-10	16-2	16-6	16-10	17-2	17-5	17-9	18-0	18-3	18-6	
2 x 10	12.0	20-8	21-6	22-3	22-11	23-8	24-3	24-10	25-5	26-0									
	16.0	18-9	19-6	20-2	20-10	21-6	22-1	22-7	23-1	23-8	24-1	24-7	25-0	25-5	25-10				
	19.2	17-8	18-4	19-0	19-7	20-2	20-9	21-3	21-9	22-3	22-8	23-1	23-7	23-11	24-4	24-9	25-1	25-5	
	24.0	16-5	17-0	17-8	18-3	18-9	19-3	19-9	20-2	20-8	21-1	21-6	21-10	22-3	22-7	22-11	23-4	23-8	
$F_b$	12.0	896	969	1,040	1,108	1,174	1,239	1,302	1,363	1,423	1,481	1,539	1,595	1,651	1,706	1,759	1,812	1,864	
	16.0	986	1,067	1,145	1,220	1,293	1,364	1,433	1,500	1,566	1,631	1,694	1,756	1,817	1,877	1,936	1,995	2,052	
	19.2	1,048	1,134	1,216	1,296	1,374	1,449	1,522	1,594	1,664	1,733	1,800	1,866	1,931	1,995	2,058	2,120	2,181	
	24.0	1,129	1,221	1,310	1,396	1,480	1,561	1,640	1,717	1,793	1,866	1,939	2,010	2,080	2,149	2,217	2,283	2,349	

**NOTE:** The required bending design value,  $F_b$ , in pounds per square inch ( $\times 0.00689$  for N/mm<sup>2</sup>) is shown at the bottom of this table and is applicable to all lumber sizes shown. Spans are shown in feet-inches (1 foot = 304.8 mm, 1 inch = 25.4 mm) and are limited to 26 feet (7925 mm) and less.

**TABLE 23-I-V-R-1—RAFTERS WITH L/240 DEFLECTION LIMITATION**  
 The allowable bending stress ( $F_b$ ) and modulus of elasticity ( $E$ ) used in this table shall be from Tables 23-I-X-1 and 23-I-X-2 only.

DESIGN CRITERIA: Strength — Live load of 20 psf (0.96 kN/m <sup>2</sup> ) plus dead load of 10 psf (0.48 kN/m <sup>2</sup> ) determines the required bending design value. Deflection — For 20 psf (0.96 kN/m <sup>2</sup> ) live load. Limited to span in inches (mm) divided by 240.																							
Rafter Size (In)	Spacing (In)	Bending Design Value, $F_b$ (psi)																					
		× 0.00689 for N/mm <sup>2</sup>																					
× 25.4 for mm		300	400	500	600	700	800	900	1000	1100	1200	1300	1400	1500	1600	1700	1800	1900	2000	2100	2200	2300	2400
2x6	12.0	7-1	8-2	9-2	10-0	10-10	11-7	12-4	13-0	13-7	14-2	14-9	15-4	15-11	16-5	16-11	17-5	17-10					
	16.0	8-2	7-1	7-11	8-8	9-5	10-0	10-8	11-3	11-9	12-4	12-10	13-3	13-9	14-2	14-8	15-1	15-8	15-11	16-3	15-2	15-7	
	18.2	5-7	6-6	7-3	7-11	8-7	9-2	9-8	10-3	10-9	11-3	11-9	12-2	12-7	13-0	13-4	13-9	14-2	14-6	14-10	15-2	15-7	
	24.0	5-0	5-10	6-6	7-1	7-8	8-2	8-8	9-2	9-7	10-0	10-5	10-10	11-3	11-7	11-11	12-4	12-8	13-0	13-3	13-7	13-11	14-2
2x8	12.0	9-4	10-10	12-1	13-3	14-4	15-3	16-3	17-1	17-11	18-9	19-6	20-3	20-11	21-7	22-3	22-11	23-7					
	16.0	8-1	9-4	10-6	11-8	12-5	13-3	14-0	14-10	15-6	16-3	16-10	17-6	18-1	18-9	19-4	19-10	20-5	20-11	21-5	20-0	20-6	
	18.2	7-5	8-7	9-7	10-6	11-4	12-1	12-10	13-6	14-2	14-10	15-5	16-0	16-7	17-1	17-7	18-1	18-7	19-1	19-7	20-0	20-6	
	24.0	6-7	7-8	8-7	9-4	10-1	10-10	11-6	12-1	12-8	13-3	13-9	14-4	14-10	15-3	15-9	16-3	16-8	17-1	17-6	17-11	18-4	18-9
2x10	12.0	11-11	13-9	15-5	16-11	18-3	19-6	20-8	21-10	22-10	23-11	24-10	25-10										
	16.0	10-4	11-11	13-4	14-8	15-10	16-11	17-11	18-11	19-10	20-8	21-6	22-4	23-1	23-11	24-7	25-4	26-0					
	18.2	9-5	10-11	12-2	13-4	14-5	15-5	16-4	17-3	18-1	18-11	19-8	20-5	21-1	21-10	22-6	23-1	23-9	24-5	25-0	25-7		
	24.0	8-5	9-9	10-11	11-11	12-11	13-9	14-8	15-5	16-2	16-11	17-7	18-3	18-11	19-6	20-1	20-8	21-3	21-10	22-4	22-10	23-5	23-11
2x12	12.0	14-6	16-8	18-9	20-6	22-2	23-9	25-2															
	16.0	12-7	14-6	16-3	17-9	19-3	20-6	21-9	23-0	24-1	25-2												
	18.2	11-6	13-3	14-10	16-3	17-6	18-9	19-11	21-0	22-0	23-0	23-11	24-10	25-8									
	24.0	10-3	11-10	13-3	14-6	15-8	16-9	17-9	18-9	19-8	20-8	21-5	22-2	23-0	23-9	24-5	25-2	25-10					
E	12.0	0.15	0.24	0.33	0.44	0.55	0.67	0.80	0.94	1.09	1.24	1.40	1.58	1.73	1.91	2.09	2.28	2.47					
	16.0	0.13	0.21	0.29	0.38	0.48	0.58	0.70	0.82	0.94	1.07	1.21	1.35	1.50	1.65	1.81	1.97	2.14	2.31	2.48			
	18.2	0.12	0.19	0.26	0.35	0.44	0.53	0.64	0.75	0.88	0.98	1.10	1.23	1.37	1.51	1.65	1.80	1.95	2.11	2.27	2.43	2.60	
	24.0	0.11	0.17	0.24	0.31	0.39	0.48	0.57	0.67	0.77	0.88	0.99	1.10	1.22	1.35	1.48	1.61	1.75	1.89	2.03	2.18	2.33	2.48

**NOTE:** The required modulus of elasticity,  $E$ , in 1,000,000 pounds per square inch (psi) (× 0.00689 for N/mm<sup>2</sup>) is shown at the bottom of this table, is limited to 2.6 million psi (17 914 N/mm<sup>2</sup>) and less, and is applicable to all lumber sizes shown. Spans are shown in feet-inches (1 foot = 304.8 mm, 1 inch = 25.4 mm) and are limited to 26 feet (7925 mm) and less.

**TABLE 23-I-V-R-2—RAFTERS WITH L/240 DEFLECTION LIMITATION**  
 The allowable bending stress ( $F_b$ ) and modulus of elasticity ( $E$ ) used in this table shall be from Tables 23-I-X-1 and 23-I-X-2 only.

DESIGN CRITERIA: Strength — Live load of 30 (1.44 kN/m <sup>2</sup> ) psf plus dead load of 10 psf (0.48 kN/m <sup>2</sup> ) determines the required bending design value. Deflection — For 30 psf (1.44 kN/m <sup>2</sup> ) live load. Limited to span in inches (mm) divided by 240.																							
Rafter Size (in)	Spacing (in)	Bending Design Value, $F_b$ (psi)																					
		× 0.00689 for N/mm <sup>2</sup>																					
× 25.4 for mm		300	400	500	600	700	800	900	1000	1100	1200	1300	1400	1500	1600	1700	1800	1900	2000	2100	2200	2300	2400
2x6	12.0	6-2	7-1	7-11	8-8	8-5	10-0	10-8	11-3	11-9	12-4	12-10	13-3	13-8	14-2	14-8	15-1	15-8	15-11				
	16.0	5-4	6-2	6-10	7-6	8-2	8-8	9-3	9-9	10-2	10-8	11-1	11-6	11-11	12-4	12-8	13-1	13-5	13-9	14-1	14-5		
	18.2	4-10	5-7	6-3	6-10	7-5	7-11	8-5	8-11	9-4	9-9	10-1	10-6	10-10	11-3	11-7	11-11	12-3	12-7	12-10	13-2	13-6	
	24.0	4-4	5-0	5-7	6-2	6-8	7-1	7-6	7-11	8-4	8-8	9-1	9-5	9-9	10-0	10-4	10-8	10-11	11-3	11-6	11-9	12-0	12-4
2x8	12.0	8-1	9-4	10-8	11-8	12-5	13-3	14-0	14-10	15-6	16-3	16-10	17-6	18-1	18-9	19-4	19-10	20-5	20-11				
	16.0	7-0	8-1	9-1	9-11	10-9	11-6	12-2	12-10	13-5	14-0	14-7	15-2	15-8	16-3	16-9	17-2	17-8	18-1	18-7	19-0		
	18.2	6-5	7-5	8-3	8-1	9-9	10-6	11-1	11-8	12-3	12-10	13-4	13-10	14-4	14-10	15-3	15-8	16-2	16-7	16-11	17-4	17-9	
	24.0	5-9	6-7	7-5	8-1	8-9	8-4	9-11	10-6	11-0	11-6	11-11	12-5	12-10	13-3	13-8	14-0	14-5	14-10	15-2	15-8	15-10	16-3
2x10	12.0	10-4	11-11	13-4	14-8	15-10	16-11	17-11	18-11	19-10	20-8	21-8	22-4	23-1	23-11	24-7	25-4	26-0					
	16.0	8-11	10-4	11-7	12-8	13-8	14-8	15-6	16-4	17-2	17-11	18-8	19-4	20-0	20-8	21-4	21-11	22-6	23-1	23-8	24-3		
	18.2	8-2	9-5	10-7	11-7	12-6	13-4	14-2	14-11	15-8	16-4	17-0	17-8	18-3	18-11	19-6	20-0	20-7	21-1	21-8	22-2	22-8	
	24.0	7-4	8-5	9-5	10-4	11-2	11-11	12-8	13-4	14-0	14-8	15-3	15-10	16-4	16-11	17-5	17-11	18-5	18-11	19-4	19-10	20-3	20-8
2x12	12.0	12-7	14-6	16-3	17-9	18-3	20-6	21-9	23-0	24-1	25-2												
	16.0	10-11	12-7	14-1	15-5	16-8	17-9	18-10	18-11	20-10	21-9	22-8	23-6	24-4	25-2	25-11							
	18.2	9-11	11-6	12-10	14-1	15-2	16-3	17-3	18-2	19-0	19-11	20-8	21-6	22-3	23-0	23-8	24-4	25-0	25-8				
	24.0	8-11	10-3	11-6	12-7	13-7	14-6	15-5	16-3	17-0	17-9	18-6	19-3	19-11	20-6	21-2	21-9	22-5	23-0	23-6	24-1	24-8	25-2
E	12.0	0.15	0.23	0.32	0.43	0.54	0.66	0.78	0.92	1.06	1.21	1.38	1.52	1.69	1.88	2.04	2.22	2.41	2.60				
	16.0	0.13	0.20	0.28	0.37	0.47	0.57	0.68	0.80	0.92	1.05	1.18	1.32	1.46	1.61	1.76	1.92	2.08	2.25	2.42	2.60		
	18.2	0.12	0.18	0.26	0.34	0.43	0.52	0.62	0.73	0.84	0.95	1.08	1.20	1.33	1.47	1.61	1.75	1.90	2.05	2.21	2.37	2.53	
	24.0	0.11	0.16	0.23	0.30	0.38	0.46	0.55	0.65	0.75	0.85	0.96	1.08	1.19	1.31	1.44	1.57	1.70	1.84	1.98	2.12	2.27	2.41

**NOTE:** The required modulus of elasticity,  $E$ , in 1,000,000 pounds per square inch (psi) (× 0.00689 for N/mm<sup>2</sup>) is shown at the bottom of this table, is limited to 2.6 million psi (17 914 N/mm<sup>2</sup>) and less, and is applicable to all lumber sizes shown. Spans are shown in feet-inches (1 foot = 304.8 mm, 1 inch = 25.4 mm) and are limited to 26 feet (7925 mm) and less.

**TABLE 23-I-V-R-3—RAFTERS WITH L/240 DEFLECTION LIMITATION**  
 The allowable bending stress ( $F_b$ ) and modulus of elasticity ( $E$ ) used in this table shall be from Tables 23-I-X-1 and 23-I-X-2 only.

DESIGN CRITERIA: Strength — Live load of 20 psf (0.96 kN/m <sup>2</sup> ) plus dead load of 15 psf (0.72 kN/m <sup>2</sup> ) determines the required bending design value. Deflection — For 20 psf (0.96 kN/m <sup>2</sup> ) live load. Limited to span in inches (mm) divided by 240.																											
Rafter Size (in)	Spacing (in)	Bending Design Value, $F_b$ (psi)																									
		× 0.00689 for N/mm <sup>2</sup>																									
× 25.4 for mm		300	400	500	600	700	800	900	1000	1100	1200	1300	1400	1500	1600	1700	1800	1900	2000	2100	2200	2300	2400	2500	2600	2700	
2x8	12.0	8-7	7-7	8-8	9-4	10-0	10-9	11-5	12-8	12-7	13-2	13-8	14-2	14-8	15-2	15-8	16-1	16-7	17-0	17-5	17-10						
	16.0	5-8	6-7	7-4	8-1	8-8	9-4	9-10	10-5	10-11	11-5	11-10	12-4	12-9	13-2	13-7	13-11	14-4	14-8	15-1	15-5	15-9	16-1	16-5			
	18.2	5-2	6-0	6-8	7-4	7-11	8-8	8-8	9-8	9-11	10-5	10-10	11-3	11-7	12-0	12-4	12-9	13-1	13-5	13-9	14-1	14-5	14-8	15-0	15-4		
	24.0	4-8	5-4	6-0	6-7	7-1	7-7	8-1	8-8	9-11	9-4	9-8	10-0	10-5	10-8	11-1	11-5	11-8	12-0	12-4	12-7	12-10	13-2	13-5	13-8	13-11	
2x8	12.0	8-8	10-0	11-2	12-3	13-3	14-2	15-0	15-10	16-7	17-4	18-0	18-5	18-5	19-8	20-8	21-3	21-10	22-4	22-11	23-8						
	16.0	7-8	8-8	9-8	10-7	11-8	12-8	13-8	14-4	15-0	15-7	16-3	16-9	17-4	17-10	18-5	18-11	19-5	19-10	20-4	20-9	21-3	21-8				
	18.2	8-10	7-11	8-10	9-8	10-0	11-2	11-10	12-0	13-1	13-8	14-3	14-10	15-4	15-10	16-4	16-9	17-3	17-8	18-1	18-7	19-0	19-5	19-9	20-2		
	24.0	8-2	7-1	7-11	8-8	9-4	10-0	10-7	11-2	11-9	12-3	12-9	13-3	13-8	14-2	14-7	15-0	15-5	15-10	16-3	16-7	17-0	17-4	17-8	18-0	18-5	
2x10	12.0	11-1	12-8	14-3	15-8	16-11	18-1	19-2	20-2	21-2	22-1	23-0	23-11	24-0	25-0												
	16.0	9-7	11-1	12-4	13-8	14-8	15-8	16-7	17-8	18-4	19-2	19-11	20-8	21-5	22-1	22-10	23-5	24-1	24-9	25-4	25-11						
	18.2	8-8	10-1	11-3	12-4	13-4	14-3	15-2	15-11	16-9	17-8	18-2	18-11	19-7	20-2	20-10	21-5	22-0	22-7	23-1	23-8	24-2	24-9	25-3	25-9		
	24.0	7-10	8-8	10-1	11-1	11-11	12-0	13-0	14-3	15-0	15-8	16-3	16-11	17-6	18-1	18-7	19-2	19-8	20-2	20-8	21-2	21-8	22-1	22-7	23-0	23-5	
2x12	12.0	13-5	15-8	17-4	18-10	20-0	21-11	23-3	24-7	25-9																	
	16.0	11-8	13-5	15-0	16-8	17-9	19-0	20-2	21-3	22-4	23-3	24-3	25-2	26-0													
	18.2	10-8	12-8	13-9	15-0	16-3	17-4	18-5	19-5	20-4	21-3	22-2	23-0	23-9	24-7	25-4	26-0										
	24.0	9-8	11-0	12-3	13-5	14-8	15-8	16-8	17-4	18-2	19-0	19-10	20-8	21-3	21-11	22-8	23-3	23-11	24-7	25-2	25-9						
E	12.0	0.12	0.19	0.28	0.35	0.44	0.54	0.64	0.75	0.86	0.98	1.11	1.24	1.37	1.51	1.66	1.81	1.96	2.12	2.28	2.44						
	16.0	0.11	0.18	0.23	0.30	0.38	0.46	0.55	0.65	0.75	0.85	0.98	1.07	1.19	1.31	1.44	1.58	1.70	1.83	1.97	2.11	2.26	2.41	2.56			
	18.2	0.10	0.15	0.21	0.27	0.35	0.42	0.51	0.59	0.68	0.78	0.88	0.98	1.08	1.20	1.31	1.43	1.55	1.67	1.80	1.93	2.08	2.23	2.34	2.48		
	24.0	0.09	0.13	0.18	0.25	0.31	0.38	0.45	0.53	0.61	0.70	0.79	0.89	0.97	1.07	1.17	1.28	1.39	1.50	1.61	1.73	1.85	1.97	2.09	2.22	2.36	

**NOTE:** The required modulus of elasticity,  $E$ , in 1,000,000 pounds per square inch (psi) (× 0.00689 for N/mm<sup>2</sup>) is shown at the bottom of this table, is limited to 2.6 million psi (17 914 N/mm<sup>2</sup>) and less, and is applicable to all lumber sizes shown. Spans are shown in feet-inches (1 foot = 304.8 mm, 1 inch = 25.4 mm) and are limited to 26 feet (7925 mm) and less.

**TABLE 23-I-V-R-4—RAFTERS WITH L/240 DEFLECTION LIMITATION**  
 The allowable bending stress ( $F_b$ ) and modulus of elasticity ( $E$ ) used in this table shall be from Tables 23-I-X-1 and 23-I-X-2 only.

Raft- er Size (in)		Spac- ing (in)		Bending Design Value, $F_b$ (psi)																							
				$\times 0.00689$ for N/mm <sup>2</sup>																							
$\times 25.4$ for mm		300	400	500	600	700	800	900	1000	1100	1200	1300	1400	1500	1600	1700	1800	1900	2000	2100	2200	2300	2400	2500	2600	2700	
2x6	12.0	5-10	6-8	7-8	8-2	8-10	8-8	8-8	8-7	11-1	11-7	12-1	12-8	13-0	13-5	13-10	14-2	14-7	15-0	15-4	15-8						
	16.0	5-8	5-10	6-6	7-1	7-8	8-2	8-8	8-2	8-7	10-0	10-5	10-10	11-3	11-7	11-11	12-4	12-8	13-0	13-3	13-7	13-11	14-2				
	18.2	4-7	5-4	5-11	6-6	7-0	7-8	7-11	8-4	8-8	9-2	8-8	9-11	10-3	10-7	10-11	11-3	11-8	11-10	12-2	12-5	12-8	13-0	13-3	13-8	13-8	
	24.0	4-1	4-9	5-4	5-10	6-3	6-8	7-1	7-8	7-10	8-2	8-8	9-10	9-2	9-8	9-8	10-0	10-4	10-7	10-10	11-1	11-4	11-7	11-10	12-1	12-4	
2x8	12.0	7-8	8-10	8-10	10-10	11-8	12-8	13-3	13-11	14-8	15-3	15-11	16-8	17-1	17-8	18-2	18-8	19-3	19-8	20-3	20-8						
	16.0	8-7	7-8	8-7	9-4	10-1	10-10	11-8	12-1	12-8	13-3	13-8	14-4	14-10	15-3	15-8	16-3	16-8	17-1	17-8	17-11	18-4	18-8				
	18.2	8-8	7-8	7-10	8-7	9-3	9-10	10-8	11-8	11-7	12-1	12-7	13-1	13-8	13-11	14-5	14-10	15-2	15-7	16-8	16-4	16-8	17-1	17-5	17-8		
	24.0	6-5	6-3	7-8	7-8	8-3	8-10	9-4	9-10	10-4	10-10	11-3	11-8	12-1	12-8	12-10	13-3	13-7	13-11	14-4	14-8	15-8	15-3	15-7	15-11	16-3	
2x10	12.0	8-8	11-3	12-7	13-8	14-11	15-11	16-11	17-10	18-8	19-8	20-4	21-1	21-10	22-8	23-3	23-11	24-8	25-2	25-10							
	16.0	8-5	9-9	10-11	11-11	12-11	13-9	14-8	15-5	16-2	16-11	17-7	18-3	18-11	19-8	20-1	20-8	21-3	21-10	22-4	22-10	23-5	23-11				
	18.2	7-8	8-11	8-11	10-11	11-8	12-7	13-4	14-1	14-8	15-5	16-1	16-8	17-3	17-10	18-4	18-11	19-5	19-11	20-5	20-10	21-4	21-10	22-3	22-8		
	24.0	8-11	8-8	8-11	9-9	10-8	11-3	11-11	12-7	13-2	13-9	14-4	14-11	15-5	15-11	16-5	16-11	17-4	17-10	18-3	18-8	19-1	19-8	19-11	20-4	20-8	
2x12	12.0	11-10	13-3	15-4	16-8	18-1	19-4	20-8	21-8	22-8	23-8	24-8	25-7														
	16.0	10-3	11-10	12-3	14-8	15-8	16-8	17-8	18-8	19-8	20-8	21-5	22-2	23-8	23-8	24-5	25-2	25-10									
	18.2	9-4	10-10	12-1	13-3	14-4	15-4	16-3	17-1	17-11	18-8	19-8	20-3	21-8	21-8	22-4	23-8	23-7	24-2	24-10	25-5	25-11					
	24.0	8-5	9-8	10-10	11-10	12-10	13-3	14-8	15-4	16-1	16-8	17-5	18-1	18-8	19-4	20-8	20-8	21-1	21-8	22-2	22-8	23-3	23-8	24-2	24-8	25-2	
E	12.0	0.13	0.19	0.27	0.38	0.45	0.55	0.68	0.77	0.89	1.01	1.14	1.28	1.41	1.56	1.71	1.88	2.02	2.18	2.34	2.51						
	16.0	0.11	0.17	0.24	0.31	0.39	0.48	0.57	0.67	0.77	0.88	0.99	1.10	1.22	1.35	1.48	1.61	1.75	1.89	2.03	2.18	2.33	2.48				
	18.2	0.10	0.15	0.22	0.28	0.36	0.44	0.52	0.61	0.70	0.80	0.90	1.01	1.12	1.23	1.35	1.47	1.59	1.72	1.85	1.99	2.12	2.26	2.41	2.56		
	24.0	0.09	0.14	0.19	0.25	0.32	0.39	0.46	0.54	0.63	0.72	0.81	0.90	1.00	1.10	1.21	1.31	1.43	1.54	1.66	1.78	1.90	2.02	2.15	2.28	2.41	

**NOTE:** The required modulus of elasticity,  $E$ , in 1,000,000 pounds per square inch (psi) ( $\times 0.00689$  for N/mm<sup>2</sup>) is shown at the bottom of this table, is limited to 2.6 million psi (17 914 N/mm<sup>2</sup>) and less, and is applicable to all lumber sizes shown. Spans are shown in feet-inches (1 foot = 304.8 mm, 1 inch = 25.4 mm) and are limited to 26 feet (7925 mm) and less.

**TABLE 23-I-V-R-5—RAFTERS WITH L/240 DEFLECTION LIMITATION**  
 The allowable bending stress ( $F_b$ ) and modulus of elasticity ( $E$ ) used in this table shall be from Tables 23-I-X-1 and 23-I-X-2 only.

Raft- er Size (in)		Spac- ing (in)		Bending Design Value, $F_b$ (psi)																							
				$\times 0.00689$ for N/mm <sup>2</sup>																							
$\times 25.4$ for mm		300	400	500	600	700	800	900	1000	1100	1200	1300	1400	1500	1600	1700	1800	1900	2000	2100	2200	2300	2400	2500	2600	2700	
2x6	12.0	8-2	7-1	7-11	8-8	8-5	10-0	10-8	11-3	11-9	12-4	12-10	13-3	13-9	14-2	14-8	15-1	15-8	15-11	16-3	16-8	17-0	17-5	17-8	18-1		
	18.0	5-4	8-2	8-10	7-8	8-2	8-8	9-3	9-9	10-2	10-8	11-1	11-8	11-11	12-4	12-8	13-1	13-5	13-9	14-1	14-5	14-9	15-1	15-4	15-8	16-0	
	18.2	4-10	5-7	8-3	8-10	7-5	7-11	8-5	8-11	9-4	9-9	10-1	10-8	10-10	11-3	11-7	11-11	12-3	12-7	12-10	13-2	13-8	13-9	14-0	14-4	14-7	
	24.0	4-4	5-0	5-7	8-2	8-8	7-1	7-8	7-11	8-4	8-8	8-1	9-5	9-9	10-0	10-4	10-8	10-11	11-3	11-8	11-9	12-0	12-4	12-7	12-10	13-1	
2x8	12.0	9-1	8-4	10-8	11-0	12-5	13-3	14-0	14-10	15-8	16-3	16-10	17-8	18-1	18-9	19-4	19-10	20-5	20-11	21-5	21-11	22-5	22-11	23-5	23-10		
	18.0	7-0	8-1	8-1	9-11	10-9	11-0	12-2	12-10	13-5	14-0	14-7	15-2	15-8	16-3	16-8	17-2	17-8	18-1	18-7	19-0	19-5	19-10	20-3	20-8	21-1	
	18.2	8-5	7-5	8-3	8-1	9-9	10-8	11-1	11-8	12-3	12-10	13-4	13-10	14-4	14-10	15-3	15-8	16-2	16-7	16-11	17-4	17-9	18-1	18-8	18-10	19-3	
	24.0	5-9	8-7	7-5	8-1	8-9	9-4	9-11	10-8	11-0	11-8	11-11	12-5	12-10	13-3	13-8	14-0	14-5	14-10	15-2	15-8	15-10	16-3	16-7	16-10	17-2	
2x10	12.0	10-4	11-11	13-4	14-8	15-10	16-11	17-11	18-11	19-10	20-8	21-8	22-4	23-1	23-11	24-7	25-4	26-0									
	18.0	8-11	10-4	11-7	12-8	13-8	14-0	15-8	16-4	17-2	17-11	18-8	19-4	20-8	20-8	21-4	21-11	22-8	23-1	23-8	24-3	24-10	25-4	25-10			
	18.2	9-2	9-5	10-7	11-7	12-8	13-4	14-2	14-11	15-8	16-4	17-0	17-8	18-3	18-11	19-8	20-8	20-7	21-1	21-8	22-2	22-8	23-1	23-7	24-1	24-8	
	24.0	7-4	8-5	9-5	10-4	11-2	11-11	12-8	13-4	14-0	14-8	15-3	15-10	16-4	16-11	17-5	17-11	18-5	18-11	19-4	19-10	20-3	20-8	21-1	21-8	21-11	
2x12	12.0	12-7	14-8	16-3	17-8	18-3	20-8	21-9	23-8	24-1	25-2																
	18.0	10-11	12-7	14-1	15-5	16-8	17-9	18-10	19-11	20-10	21-9	22-8	23-8	24-4	25-2	25-11											
	18.2	9-11	11-8	12-10	14-1	15-2	16-3	17-3	18-2	19-0	19-11	20-8	21-8	22-3	23-0	23-8	24-4	25-0	25-8								
	24.0	8-11	10-3	11-8	12-7	13-7	14-8	15-5	16-3	17-0	17-9	18-0	19-3	19-11	20-6	21-2	21-9	22-5	23-0	23-8	24-1	24-8	25-2	25-8			
E	12.0	0.10	0.15	0.22	0.28	0.30	0.44	0.52	0.61	0.71	0.80	0.91	1.01	1.13	1.24	1.36	1.48	1.60	1.78	1.88	2.00	2.14	2.28	2.42	2.57		
	18.0	0.80	0.13	0.19	0.25	0.31	0.38	0.45	0.53	0.61	0.70	0.79	0.88	0.97	1.07	1.18	1.29	1.39	1.50	1.61	1.73	1.85	1.97	2.10	2.22	2.35	
	18.2	0.88	0.12	0.17	0.23	0.29	0.35	0.41	0.48	0.56	0.64	0.72	0.80	0.89	0.98	1.07	1.17	1.27	1.37	1.47	1.58	1.69	1.80	1.91	2.03	2.15	
	24.0	0.97	0.11	0.15	0.20	0.25	0.31	0.37	0.43	0.50	0.57	0.64	0.72	0.80	0.88	0.96	1.05	1.13	1.22	1.32	1.41	1.51	1.61	1.71	1.82	1.92	

**NOTE:** The required modulus of elasticity,  $E$ , in 1,000,000 pounds per square inch (psi) ( $\times 0.00689$  for N/mm<sup>2</sup>) is shown at the bottom of this table, is limited to 2.6 million psi (17 914 N/mm<sup>2</sup>) and less, and is applicable to all lumber sizes shown. Spans are shown in feet-inches (1 foot = 304.8 mm, 1 inch = 25.4 mm) and are limited to 26 feet (7925 mm) and less.

**TABLE 23-I-V-R-6—RAFTERS WITH L/240 DEFLECTION LIMITATION**  
 The allowable bending stress ( $F_b$ ) and modulus of elasticity ( $E$ ) used in this table shall be from Tables 23-I-X-1 and 23-I-X-2 only.

**DESIGN CRITERIA:**  
 Strength — Live load of 30 psf (1.44 kN/m<sup>2</sup>) plus dead load of 20 psf (0.96 kN/m<sup>2</sup>) determines the required bending design value.  
 Deflection — For 30 psf (1.44 kN/m<sup>2</sup>) live load.  
 Limited to span in inches (mm) divided by 240.

Rafter Size (in)	Spacing (in)	Bending Design Value, $F_b$ (psi)																								
		$\times 0.00689$ for N/mm <sup>2</sup>																								
	$\times 25.4$ for mm	300	400	500	600	700	800	900	1000	1100	1200	1300	1400	1500	1600	1700	1800	1900	2000	2100	2200	2300	2400	2500	2600	2700
2x6	12.0	5-0	6-4	7-1	7-9	8-5	9-0	9-8	10-0	10-8	11-0	11-5	11-11	12-4	12-8	13-1	13-8	13-10	14-2	14-7	14-11	15-3	15-7	15-11		
	18.0	4-3	5-6	6-2	6-8	7-3	7-9	8-2	8-8	9-1	9-8	9-11	10-3	10-8	11-0	11-4	11-8	12-0	12-4	12-7	12-11	13-2	13-6	13-9	14-0	14-3
	19.2	4-4	5-8	5-7	6-2	6-8	7-1	7-8	7-11	8-4	8-8	9-1	9-5	9-9	10-0	10-4	10-8	10-11	11-3	11-8	11-9	12-0	12-4	12-7	12-10	13-1
	24.0	3-11	4-8	5-0	5-8	5-11	6-4	6-8	7-1	7-5	7-9	8-1	8-5	8-8	9-0	9-3	9-6	9-9	10-0	10-3	10-6	10-8	11-0	11-3	11-5	11-8
2x8	12.0	7-3	8-4	9-4	10-3	11-1	11-10	12-7	13-3	13-11	14-8	15-1	15-8	16-3	16-9	17-3	17-9	18-3	18-9	19-2	19-8	20-1	20-6	20-11		
	18.0	6-3	7-3	8-1	8-11	9-7	10-3	10-10	11-8	12-0	12-7	13-1	13-7	14-0	14-6	14-11	15-5	15-10	16-3	16-7	17-0	17-5	17-9	18-1	18-6	18-10
	19.2	5-9	6-7	7-5	8-1	8-9	9-4	9-11	10-8	11-0	11-6	11-11	12-5	12-10	13-3	13-8	14-0	14-5	14-10	15-2	15-6	15-10	16-3	16-7	16-10	17-2
	24.0	5-2	5-11	6-7	7-3	7-10	8-4	8-11	9-4	9-10	10-3	10-8	11-1	11-8	11-10	12-2	12-7	12-11	13-3	13-7	13-11	14-2	14-6	14-10	15-1	15-5
2x10	12.0	9-3	10-8	11-11	13-1	14-2	15-1	16-0	16-11	17-9	18-8	19-3	20-0	20-8	21-4	22-0	22-8	23-3	23-11	24-6	25-1	25-7				
	18.0	8-0	9-3	10-4	11-4	12-3	13-1	13-10	14-8	15-4	16-0	16-8	17-4	17-11	18-6	19-1	19-7	20-2	20-8	21-2	21-8	22-2	22-8	23-1	23-7	24-0
	19.2	7-4	8-5	9-5	10-4	11-2	11-11	12-8	13-4	14-0	14-8	15-3	15-10	16-4	16-11	17-5	17-11	18-5	18-11	19-4	19-10	20-3	20-8	21-1	21-8	21-11
	24.0	6-8	7-7	8-5	9-3	10-0	10-8	11-4	11-11	12-6	13-1	13-7	14-2	14-8	15-1	15-7	16-0	16-6	16-11	17-4	17-9	18-1	18-6	18-11	19-3	19-7
2x12	12.0	11-3	13-0	14-8	15-11	17-2	18-4	19-8	20-6	21-7	22-6	23-5	24-4	25-2	26-0											
	18.0	9-8	11-3	12-7	13-9	14-11	15-11	16-10	17-9	18-3	18-8	20-3	21-1	21-9	22-6	23-2	23-10	24-6	25-2	25-9						
	19.2	8-11	10-3	11-8	12-7	13-7	14-8	15-5	16-2	17-0	17-9	18-6	19-3	19-11	20-6	21-2	21-9	22-5	23-9	23-6	24-1	24-8	25-2	25-8		
	24.0	7-11	9-2	10-3	11-3	12-2	13-0	13-9	14-6	15-3	15-11	16-7	17-2	17-9	18-4	18-11	19-6	20-0	20-8	21-1	21-7	22-0	22-6	23-0	23-5	23-10
E	12.0	0.11	0.17	0.23	0.31	0.39	0.47	0.56	0.66	0.76	0.86	0.97	1.09	1.21	1.33	1.46	1.59	1.72	1.86	2.00	2.14	2.29	2.44	2.60		
	18.0	0.09	0.14	0.20	0.26	0.33	0.41	0.49	0.57	0.66	0.75	0.84	0.94	1.05	1.15	1.26	1.37	1.48	1.61	1.73	1.86	1.99	2.12	2.25	2.39	
	19.2	0.09	0.13	0.18	0.24	0.30	0.37	0.44	0.52	0.60	0.68	0.77	0.86	0.95	1.05	1.15	1.25	1.36	1.47	1.58	1.70	1.81	1.93	2.05	2.18	
	24.0	0.08	0.12	0.16	0.22	0.27	0.33	0.40	0.48	0.54	0.61	0.69	0.77	0.85	0.94	1.03	1.12	1.22	1.31	1.41	1.52	1.62	1.73	1.84	1.95	

**NOTE:** The required modulus of elasticity,  $E$ , in 1,000,000 pounds per square inch (psi) ( $\times 0.00689$  for N/mm<sup>2</sup>) is shown at the bottom of this table, is limited to 2.6 million psi (17 914 N/mm<sup>2</sup>) and less, and is applicable to all lumber sizes shown. Spans are shown in feet-inches (1 foot = 304.8 mm, 1 inch = 25.4 mm) and are limited to 26 feet (7925 mm) and less.

**TABLE 23-I-V-R-7—RAFTERS WITH L/180 DEFLECTION LIMITATION**  
 The allowable bending stress ( $F_b$ ) and modulus of elasticity ( $E$ ) used in this table shall be from Tables 23-I-X-1 and 23-I-X-2 only.

RAFTER SIZE (in)		SPACING (in)		BENDING DESIGN VALUE, $F_b$ (psi)																											
				$\times 0.00689$ for N/mm <sup>2</sup>																											
		$\times 25.4$ for mm																													
		200	300	400	500	600	700	800	900	1000	1100	1200	1300	1400	1500	1600	1700	1800	1900	2000	2100	2200	2300	2400	2500	2600	2700	2800	2900	3000	
2 x 4	12.0	3-0	4-0	5-0	5-10	6-5	8-11	7-5	7-10	8-3	8-8	9-0	9-5	9-0	10-1	10-5	10-9	11-1	11-4	11-8	11-11	12-3	12-6								
	18.0	3-2	3-11	4-0	5-1	5-0	6-0	6-5	6-9	7-2	7-8	7-10	8-2	8-5	8-9	9-0	9-4	9-7	9-10	10-1	10-4	10-7	10-10	11-1	11-4	11-8					
	18.2	2-11	3-7	4-1	4-7	5-1	5-5	5-10	6-2	6-6	6-10	7-2	7-5	7-9	8-0	8-3	8-8	8-8	9-0	9-3	9-5	9-8	9-11	10-1	10-4	10-8	10-9				
	24.0	2-7	3-2	3-8	4-1	4-8	4-11	5-3	5-6	5-10	6-1	6-5	6-8	6-11	7-2	7-5	7-7	7-10	8-0	8-3	8-5	8-8	8-10	9-0	9-3	9-5	9-7	9-9	9-11	10-1	
2 x 6	12.0	5-10	7-1	8-2	8-2	10-0	10-10	11-7	12-4	13-0	13-7	14-2	14-8	15-4	15-11	16-5	16-11	17-5	17-10	18-4	18-9	19-3	19-8								
	18.0	5-8	6-2	7-1	7-11	8-8	8-5	10-0	10-8	11-3	11-9	12-4	12-10	13-3	13-8	14-2	14-8	15-1	15-6	15-11	16-3	16-8	17-0	17-5	17-9	18-1					
	18.2	4-7	5-7	6-0	7-3	7-11	8-7	8-2	9-9	10-3	10-9	11-3	11-8	12-2	12-7	13-0	13-4	13-9	14-2	14-6	14-10	15-2	15-7	15-11	16-2	16-6	16-10				
	24.0	4-1	5-0	5-10	6-0	7-1	7-8	8-2	8-8	9-2	9-7	10-0	10-5	10-10	11-3	11-7	11-11	12-4	12-8	13-0	13-3	13-7	13-11	14-2	14-6	14-9	15-1	15-4	15-7	15-11	
2 x 8	12.0	7-8	8-4	10-10	12-1	13-3	14-4	15-3	16-3	17-1	17-11	18-0	18-6	20-3	20-11	21-7	22-3	22-11	23-7	24-2	24-8	25-4	25-11								
	18.0	6-7	8-1	8-4	10-0	11-0	12-5	13-3	14-0	14-10	15-8	16-3	18-10	17-0	18-1	18-9	19-4	19-10	20-5	20-11	21-5	21-11	22-5	22-11	23-5	23-10					
	18.2	6-0	7-5	8-7	8-7	10-0	11-4	12-1	12-10	13-0	14-2	14-10	15-5	16-0	16-7	17-1	17-7	18-1	18-7	19-1	19-7	20-0	20-6	20-11	21-4	21-9	22-2				
	24.0	5-5	6-7	7-8	8-7	9-4	10-1	10-10	11-0	12-1	12-8	13-3	13-9	14-4	14-10	15-3	15-9	16-3	16-8	17-1	17-8	18-4	18-9	19-1	19-6	19-10	20-3	20-7	20-11		
2 x 10	12.0	9-0	11-11	13-0	15-5	16-11	18-3	19-0	20-8	21-10	22-10	23-11	24-10	25-10																	
	18.0	8-5	10-4	11-11	13-4	14-3	15-10	16-11	17-11	18-11	19-10	20-8	21-8	22-4	23-1	23-11	24-7	25-4	26-0												
	18.2	7-8	9-5	10-11	12-2	13-4	14-5	15-5	16-4	17-3	18-1	18-11	19-8	20-5	21-1	21-10	22-0	23-1	23-8	24-5	25-0	25-7									
	24.0	6-11	8-5	9-0	10-11	11-11	12-11	13-0	14-0	15-5	16-11	17-7	18-3	19-11	19-8	20-1	20-10	21-3	21-10	22-4	22-10	23-5	23-11	24-5	24-10	25-4	25-10				
E	12.0	0.80	0.12	0.18	0.25	0.33	0.41	0.51	0.60	0.71	0.82	0.93	1.05	1.17	1.30	1.43	1.57	1.71	1.85	2.00	2.15	2.31	2.47								
	18.0	0.85	0.18	0.15	0.22	0.29	0.36	0.44	0.52	0.61	0.71	0.80	0.91	1.01	1.13	1.24	1.36	1.48	1.60	1.73	1.86	2.00	2.14	2.28	2.42	2.57					
	18.2	0.85	0.80	0.14	0.20	0.26	0.33	0.40	0.48	0.56	0.64	0.73	0.83	0.93	1.03	1.13	1.24	1.35	1.46	1.58	1.70	1.82	1.95	2.08	2.21	2.34	2.48				
	24.0	0.84	0.80	0.13	0.19	0.25	0.32	0.39	0.47	0.55	0.63	0.72	0.82	0.92	1.02	1.12	1.21	1.31	1.41	1.52	1.63	1.74	1.86	1.98	2.10	2.22	2.34	2.47	2.60		

**NOTE:** The required modulus of elasticity,  $E$ , in 1,000,000 pounds per square inch (psi) ( $\times 0.00689$  for N/mm<sup>2</sup>) is shown at the bottom of this table, is limited to 2.6 million psi (17 914 N/mm<sup>2</sup>) and less, and is applicable to all lumber sizes shown. Spans are shown in feet-inches (1 foot = 304.8 mm, 1 inch = 25.4 mm) and are limited to 26 feet (7925 mm) and less.

**TABLE 23-I-V-R-8—RAFTERS WITH L/180 DEFLECTION LIMITATION**

The allowable bending stress ( $F_b$ ) and modulus of elasticity ( $E$ ) used in this table shall be from Tables 23-I-X-1 and 23-I-X-2 only.

DESIGN CRITERIA:																																			
Strength — Live load of 30 psf (1.44 kN/m <sup>2</sup> ) plus dead load of 10 psf (0.48 kN/m <sup>2</sup> ) determines the required bending design value.		Deflection — For 30 psf (1.44 kN/m <sup>2</sup> ) live load. Limited to span in inches (mm) divided by 180.																																	
RAFTER SIZE (in)	SPACING (in)	BENDING DESIGN VALUE, $F_b$ (psi)																																	
		× 0.00689 for N/mm <sup>2</sup>																																	
× 25.4 N/mm <sup>2</sup>		200	300	400	500	600	700	800	900	1000	1100	1200	1300	1400	1500	1600	1700	1800	1900	2000	2100	2200	2300	2400	2500	2600	2700	2800	2900	3000					
2 x 4	12.0	3-2	3-11	4-0	5-1	5-8	6-8	6-5	6-8	7-2	7-8	7-10	8-2	8-5	8-8	8-4	8-7	8-10	8-1	8-4	8-8	8-8	8-2	8-5	8-7	8-8	8-11	8-1	8-3	8-5					
	16.0	2-9	3-5	3-11	4-4	4-10	5-2	5-8	5-10	6-2	6-8	6-9	7-1	7-4	7-7	7-10	8-1	8-4	8-8	8-8	8-8	8-2	8-5	8-7	8-8	8-11	8-1	8-3	8-5						
	18.2	2-8	3-1	3-7	4-0	4-4	4-8	5-1	5-4	5-8	5-11	6-2	6-5	6-8	6-11	7-2	7-4	7-7	7-8	8-0	8-2	8-5	8-7	8-8	8-11	8-1	8-1	8-3	8-5						
	24.0	2-3	2-9	3-2	3-7	3-11	4-3	4-8	4-10	5-1	5-4	5-8	5-8	6-0	6-2	6-5	6-7	6-8	7-0	7-2	7-4	7-8	7-8	7-10	8-0	8-2	8-4	8-5	8-7	8-8					
2 x 6	12.0	5-0	6-2	7-1	7-11	8-8	8-5	10-0	10-8	11-3	11-9	12-4	12-10	13-3	13-9	14-2	14-8	15-1	15-8	15-11	16-3	16-8	17-0	17-5											
	16.0	4-4	5-4	6-2	6-10	7-8	8-2	8-8	8-3	8-9	10-2	10-8	11-1	11-8	11-11	12-4	12-8	13-1	13-5	13-8	14-1	14-5	14-8	15-1	15-4	15-8									
	18.2	4-0	4-10	5-7	6-3	6-10	7-5	7-11	8-5	8-11	9-4	9-9	10-1	10-8	10-10	11-3	11-7	11-11	12-3	12-7	12-10	13-2	13-6	13-9	14-0	14-4	14-7	14-10							
	24.0	3-7	4-4	5-0	5-7	6-2	6-8	7-1	7-8	7-11	8-4	8-8	9-1	9-5	9-9	10-8	10-4	10-8	10-11	11-3	11-8	11-9	12-8	12-4	12-7	12-10	13-1	13-3	13-8	13-8					
2 x 8	12.0	6-7	8-1	8-4	10-0	11-8	12-5	13-3	14-0	14-10	15-8	16-3	16-10	17-8	18-1	18-9	18-4	18-10	19-5	20-11	21-5	21-11	22-5	22-11											
	16.0	5-8	7-0	8-1	8-1	9-11	10-0	11-0	12-2	12-10	13-5	14-0	14-7	15-2	15-8	16-3	16-8	17-2	17-8	18-1	18-7	19-0	19-5	19-10	20-3	20-8									
	18.2	5-3	6-5	7-5	8-3	8-1	9-8	10-8	11-1	11-8	12-3	12-10	13-4	13-10	14-4	14-10	15-3	15-8	16-2	16-7	16-11	17-4	17-8	18-1	18-8	18-10	19-3	19-7							
	24.0	4-8	5-8	6-7	7-5	8-1	8-8	9-4	9-11	10-8	11-0	11-8	11-11	12-5	12-10	13-3	13-8	14-0	14-5	14-10	15-2	15-8	15-10	16-3	16-7	16-10	17-2	17-8	17-10	18-1					
2 x 10	12.0	8-5	10-4	11-11	13-4	14-8	15-10	16-11	17-11	18-11	18-10	20-3	21-8	22-4	23-1	23-11	24-7	25-4	26-0																
	16.0	7-4	8-11	10-4	11-7	12-8	13-8	14-8	15-8	16-4	17-2	17-11	18-8	19-4	20-0	20-8	21-4	21-11	22-6	23-1	23-8	24-3	24-10	25-4	25-10										
	18.2	6-8	8-2	9-5	10-7	11-7	12-8	13-4	14-2	14-11	15-8	16-4	17-0	17-8	18-3	18-11	19-0	20-0	20-7	21-1	21-8	22-2	22-8	23-1	23-7	24-1	24-8	25-0							
	24.0	6-0	7-4	8-5	9-5	10-4	11-2	11-11	12-8	13-4	14-8	14-8	15-3	15-10	16-4	16-11	17-5	17-11	18-5	18-11	19-4	19-10	20-3	20-8	21-1	21-6	21-11	22-4	22-8	23-8	24-1	24-8	25-1		
E	12.0	0.86	0.11	0.17	0.24	0.32	0.40	0.48	0.56	0.60	0.70	0.81	1.02	1.14	1.27	1.39	1.53	1.68	1.80	1.95	2.10	2.25	2.40	2.58											
	16.0	0.85	0.10	0.15	0.21	0.28	0.35	0.43	0.51	0.60	0.68	0.78	0.99	1.10	1.21	1.32	1.44	1.58	1.80	1.82	1.95	2.08	2.22	2.38	2.58										
	18.2	0.85	0.09	0.14	0.19	0.25	0.32	0.39	0.47	0.54	0.63	0.72	0.81	0.98	1.08	1.18	1.21	1.32	1.43	1.54	1.68	1.78	1.90	2.03	2.15	2.28	2.42	2.55							
	24.0	0.84	0.08	0.12	0.17	0.23	0.29	0.35	0.42	0.48	0.58	0.64	0.72	0.81	0.89	0.99	1.08	1.18	1.28	1.38	1.48	1.58	1.70	1.81	1.93	2.04	2.18	2.28	2.41	2.53					

NOTE: The required modulus of elasticity,  $E$ , in 1,000,000 pounds per square inch (psi) (× 0.00689 for N/mm<sup>2</sup>) is shown at the bottom of this table, is limited to 2.6 million psi (17 914 N/mm<sup>2</sup>) and less, and is applicable to all lumber sizes shown. Spans are shown in feet-inches (1 foot = 304.8 mm, 1 inch = 25.4 mm) and are limited to 26 feet (7925 mm) and less.

**TABLE 23-I-V-R-9—RAFTERS WITH L/180 DEFLECTION LIMITATION**  
 The allowable bending stress ( $F_b$ ) and modulus of elasticity ( $E$ ) used in this table shall be from Tables 23-I-X-1 and 23-I-X-2 only.

DESIGN CRITERIA:																														
Strength — Live load of 20 psf (0.96 kN/m <sup>2</sup> ) plus dead load of 15 psf (0.72 kN/m <sup>2</sup> ) determines the required bending design value.		Deflection — For 20 psf (0.96 kN/m <sup>2</sup> ) live load. Limited to span in inches (mm) divided by 180.																												
RAFTER SIZE (in)	SPACING (in)	BENDING DESIGN VALUE, $F_b$ (psi)																												
		$\times 0.00689$ for N/mm <sup>2</sup>																												
$\times 25.4$ for mm		200	300	400	500	600	700	800	900	1000	1100	1200	1300	1400	1500	1600	1700	1800	1900	2000	2100	2200	2300	2400	2500	2600	2700	2800	2900	3000
2 X 4	12.0	3-6	4-2	4-10	5-5	5-11	6-5	6-10	7-3	7-8	8-0	8-4	8-8	9-0	9-4	9-8	9-11	10-3	10-8	10-10	11-1	11-4	11-7	11-10	12-1	12-4	12-7			
	18.0	2-11	3-7	4-2	4-8	5-1	5-8	5-11	6-3	6-7	6-11	7-3	7-6	7-10	8-1	8-4	8-7	8-10	9-1	9-4	9-7	9-10	10-0	10-3	10-5	10-8	10-10	11-1	11-3	11-5
	18.2	2-8	3-4	3-10	4-3	4-8	5-1	5-5	5-9	6-0	6-4	6-7	6-11	7-2	7-5	7-8	7-10	8-1	8-4	8-8	8-8	9-11	9-2	9-4	9-7	9-9	9-11	10-1	10-3	10-5
	24.0	2-5	2-11	3-5	3-10	4-2	4-8	4-10	5-1	5-5	5-8	5-11	6-2	6-5	6-7	6-10	7-0	7-3	7-5	7-8	7-10	8-0	8-2	8-4	8-8	8-8	9-8	9-8	9-10	9-0
2 X 6	12.0	5-4	6-7	7-7	8-8	9-4	10-0	10-9	11-5	12-0	12-7	13-2	13-8	14-2	14-8	15-2	15-8	16-1	16-7	17-0	17-5	17-10	18-2	18-7	18-8	19-4	19-8			
	18.0	4-8	5-8	6-7	7-4	8-1	8-8	9-4	9-10	10-5	10-11	11-5	11-10	12-4	12-9	13-2	13-7	13-11	14-4	14-8	15-1	15-5	15-9	16-1	16-5	16-8	17-1	17-5	17-8	18-0
	18.2	4-3	5-2	6-0	6-8	7-4	7-11	8-0	8-9	9-0	9-11	10-5	10-10	11-3	11-7	12-0	12-4	12-9	13-1	13-5	13-9	14-1	14-5	14-8	15-0	15-4	15-7	15-11	16-2	16-5
	24.0	3-10	4-8	5-4	6-0	6-7	7-1	7-7	8-1	8-8	8-11	9-4	9-8	10-0	10-5	10-9	11-1	11-5	11-8	12-0	12-4	12-7	12-10	13-2	13-5	13-8	13-11	14-2	14-5	14-8
2 X 8	12.0	7-1	8-8	10-0	11-2	12-3	13-3	14-2	15-0	15-10	16-7	17-4	18-0	18-8	19-5	20-0	20-8	21-3	21-10	22-4	22-11	23-8	24-0	24-8	25-0	25-8	26-0			
	18.0	6-2	7-6	8-8	9-8	10-7	11-8	12-3	13-0	13-8	14-4	15-0	15-7	16-3	16-9	17-4	17-10	18-5	18-11	19-5	19-10	20-4	20-8	21-3	21-8	22-1	22-6	22-11	23-4	23-9
	18.2	5-7	6-10	7-11	8-10	9-8	10-8	11-2	11-10	12-0	13-1	13-8	14-3	14-10	15-4	15-10	16-4	16-9	17-3	17-8	18-1	18-7	19-0	19-5	19-9	20-2	20-7	20-11	21-4	21-8
	24.0	5-0	6-2	7-1	7-11	8-8	9-4	10-0	10-7	11-2	11-9	12-3	12-8	13-3	13-8	14-2	14-7	15-0	15-5	15-10	16-3	16-7	17-0	17-4	17-8	18-0	18-5	18-8	19-1	19-5
2 X 10	12.0	9-0	11-1	12-8	14-3	15-8	16-11	18-1	18-2	20-2	21-2	22-1	23-0	23-11	24-0	25-0														
	18.0	7-10	8-7	11-1	12-4	13-8	14-8	15-8	16-7	17-8	18-4	18-2	19-11	20-8	21-5	22-1	22-10	23-5	24-1	24-8	25-4	25-11								
	18.2	7-2	8-9	10-1	11-3	12-4	13-4	14-3	15-2	15-11	16-9	17-8	18-2	18-11	19-7	20-2	20-10	21-5	22-0	22-7	23-1	23-8	24-2	24-9	25-3	25-9				
	24.0	6-5	7-10	8-0	10-1	11-1	11-11	12-0	13-0	14-3	15-0	15-8	16-3	16-11	17-6	18-1	18-7	19-2	19-8	20-2	20-8	21-2	21-8	22-1	22-7	23-0	23-5	23-11	24-4	24-9
E	12.0	0.95	0.89	0.14	0.28	0.28	0.33	0.40	0.48	0.58	0.65	0.74	0.83	0.83	1.03	1.14	1.24	1.36	1.47	1.58	1.71	1.83	1.96	2.09	2.22	2.35	2.48			
	18.0	0.94	0.88	0.12	0.17	0.23	0.23	0.25	0.41	0.49	0.58	0.64	0.72	0.80	0.89	0.96	1.06	1.17	1.27	1.37	1.48	1.59	1.70	1.81	1.92	2.04	2.16	2.28	2.40	2.53
	18.2	0.94	0.87	0.11	0.16	0.21	0.29	0.32	0.38	0.44	0.51	0.58	0.66	0.73	0.81	0.90	0.98	1.07	1.16	1.25	1.35	1.45	1.55	1.65	1.75	1.85	1.95	2.05	2.15	2.31
	24.0	0.94	0.87	0.10	0.14	0.18	0.23	0.23	0.24	0.40	0.48	0.52	0.58	0.66	0.73	0.80	0.88	0.96	1.04	1.12	1.21	1.29	1.38	1.48	1.57	1.66	1.76	1.86	1.96	2.06

**NOTE:** The required modulus of elasticity,  $E$ , in 1,000,000 pounds per square inch (psi) ( $\times 0.00689$  for N/mm<sup>2</sup>) is shown at the bottom of this table, is limited to 2.6 million psi (17 914 N/mm<sup>2</sup>) and less, and is applicable to all lumber sizes shown. Spans are shown in feet-inches (1 foot = 304.8 mm, 1 inch = 25.4 mm) and are limited to 26 feet (7925 mm) and less.

TABLE 23-I-V-R-10—RAFTERS WITH L/180 DEFLECTION LIMITATION

The allowable bending stress ( $F_b$ ) and modulus of elasticity ( $E$ ) used in this table shall be from Tables 23-I-X-1 and 23-I-X-2 only.

DESIGN CRITERIA:																														
Strength — Live load of 30 (1.44 kN/m <sup>2</sup> ) psf plus dead load of 15 psf (0.72 kN/m <sup>2</sup> ) determines the required bending design value.		Deflection — For 30 psf (1.44 kN/m <sup>2</sup> ) live load. Limited to span in inches (mm) divided by 180.																												
RAFTER SIZE (in)	SPACING (in)	BENDING DESIGN VALUE, $F_b$ (psi)																												
		× 0.00689 for N/mm <sup>2</sup>																												
× 25.4 for mm		200	300	400	500	600	700	800	900	1000	1100	1200	1300	1400	1500	1600	1700	1800	1900	2000	2100	2200	2300	2400	2500	2600	2700	2800	2900	3000
2 X 4	12.0	3-0	3-8	4-3	4-8	5-3	5-8	6-3	6-8	7-1	7-5	7-8	8-0	8-3	8-5	8-8	8-9	8-9	8-9	8-9	8-9	8-9	8-9	8-9	8-9	8-9	8-9	8-9	8-9	8-9
	16.0	2-7	3-2	3-8	4-1	4-6	4-11	5-3	5-8	5-10	6-1	6-5	6-8	6-11	7-2	7-5	7-7	7-10	8-0	8-3	8-5	8-8	8-10	9-0	9-3	9-5	9-7	9-8	9-11	10-1
	18.2	2-5	2-11	3-4	3-9	4-1	4-5	4-9	5-1	5-4	5-7	5-10	6-1	6-4	6-8	6-9	6-11	7-2	7-4	7-6	7-9	7-11	8-1	8-3	8-5	8-7	8-8	8-11	9-1	9-3
	24.0	2-2	2-7	3-0	3-4	3-8	4-0	4-3	4-6	4-8	5-0	5-3	5-5	5-8	5-10	6-0	6-3	6-5	6-7	6-8	6-11	7-1	7-3	7-5	7-6	7-8	7-10	8-0	8-1	8-3
2 X 6	12.0	4-0	5-10	6-8	7-8	8-2	8-10	8-8	10-0	10-7	11-1	11-7	12-1	12-8	13-0	13-5	13-10	14-2	14-7	15-0	15-4	15-8	16-1	16-5	16-9	17-1	17-5			
	16.0	4-1	5-8	5-10	6-8	7-1	7-8	8-2	8-8	8-2	9-7	10-0	10-5	10-10	11-3	11-7	11-11	12-4	12-8	13-0	13-3	13-7	13-11	14-2	14-6	14-9	15-1	15-4	15-7	15-11
	18.2	3-9	4-7	5-4	5-11	6-0	7-0	7-8	7-11	8-4	8-8	9-2	9-6	9-11	10-3	10-7	10-11	11-3	11-6	11-10	12-2	12-5	12-8	13-0	13-3	13-6	13-9	14-0	14-3	14-6
	24.0	3-4	4-1	4-9	5-4	5-10	6-3	6-8	7-1	7-8	7-10	8-2	8-6	8-10	8-2	8-6	8-9	10-0	10-4	10-7	10-10	11-1	11-4	11-7	11-10	12-1	12-4	12-8	12-9	13-0
2 X 8	12.0	6-3	7-8	8-10	9-10	10-10	11-8	12-8	13-3	13-11	14-8	15-3	15-11	16-6	17-1	17-8	18-2	18-9	19-3	19-8	20-3	20-8	21-2	21-7	22-1	22-6	22-11			
	16.0	5-5	6-7	7-8	8-7	9-4	10-1	10-10	11-6	12-1	12-8	13-3	13-8	14-4	14-10	15-3	15-8	16-3	16-8	17-1	17-6	17-11	18-4	18-9	19-1	19-6	19-10	20-3	20-7	20-11
	18.2	4-11	6-0	7-0	7-10	8-7	9-3	9-10	10-6	11-0	11-7	12-1	12-7	13-1	13-6	13-11	14-5	14-10	15-2	15-7	16-0	16-4	16-9	17-1	17-5	17-9	18-1	18-5	18-9	18-1
	24.0	4-5	5-5	6-3	7-0	7-8	8-3	8-10	9-4	9-10	10-4	10-10	11-3	11-8	12-1	12-6	12-10	13-3	13-7	13-11	14-4	14-8	15-0	15-3	15-7	15-11	16-3	16-6	16-10	17-1
2 X 10	12.0	8-0	9-9	11-3	12-7	13-9	14-11	15-11	16-11	17-10	18-8	19-6	20-4	21-1	21-10	22-8	23-3	23-11	24-8	25-2	25-10									
	16.0	6-11	8-5	9-8	10-11	11-11	12-11	13-9	14-8	15-5	16-2	16-11	17-7	18-3	18-11	19-8	20-1	20-8	21-3	21-10	22-4	22-10	23-5	23-11	24-5	24-10	25-4	25-10		
	18.2	6-4	7-8	8-11	9-11	10-11	11-8	12-7	13-4	14-1	14-9	15-5	16-1	16-8	17-3	17-10	18-4	18-11	19-5	19-11	20-5	20-10	21-4	21-10	22-3	22-8	23-1	23-7	24-0	24-5
	24.0	5-8	6-11	8-0	8-11	9-9	10-8	11-3	11-11	12-7	13-2	13-9	14-4	14-11	15-5	15-11	16-5	16-11	17-4	17-10	18-3	18-8	19-1	19-6	20-4	20-9	21-1	21-5	21-10	
E	12.0	0.85	0.80	0.15	0.28	0.27	0.34	0.41	0.48	0.58	0.67	0.78	0.86	0.96	1.06	1.17	1.28	1.39	1.51	1.63	1.76	1.88	2.01	2.15	2.28	2.42	2.58			
	16.0	0.84	0.80	0.12	0.18	0.23	0.29	0.36	0.43	0.50	0.58	0.66	0.74	0.83	0.92	1.01	1.11	1.21	1.31	1.41	1.52	1.63	1.74	1.86	1.98	2.10	2.22	2.34	2.47	2.60
	18.2	0.84	0.80	0.12	0.18	0.21	0.27	0.33	0.39	0.46	0.53	0.60	0.68	0.76	0.84	0.92	1.01	1.10	1.20	1.29	1.38	1.49	1.59	1.70	1.80	1.91	2.03	2.14	2.25	2.37
	24.0	0.84	0.87	0.10	0.14	0.18	0.24	0.29	0.35	0.41	0.47	0.54	0.61	0.68	0.75	0.83	0.90	0.98	1.07	1.15	1.24	1.32	1.42	1.52	1.61	1.71	1.81	1.91	2.02	2.12

NOTE: The required modulus of elasticity,  $E$ , in 1,000,000 pounds per square inch (psi) (× 0.00689 for N/mm<sup>2</sup>) is shown at the bottom of this table, is limited to 2.6 million psi (17 914 N/mm<sup>2</sup>) and less, and is applicable to all lumber sizes shown. Spans are shown in feet-inches (1 foot = 304.8 mm, 1 inch = 25.4 mm) and are limited to 26 feet (7925 mm) and less.

**TABLE 23-I-V-R-11—RAFTERS WITH L/180 DEFLECTION LIMITATION**  
 The allowable bending stress ( $F_b$ ) and modulus of elasticity ( $E$ ) used in this table shall be from Tables 23-I-X-1 and 23-I-X-2 only.

DESIGN CRITERIA:																															
Strength — Live load of 20 psf (0.96 kN/m <sup>2</sup> ) plus dead load of 20 psf (0.96 kN/m <sup>2</sup> ) determines the required bending design value.		Deflection — For 20 psf (0.96 kN/m <sup>2</sup> ) live load. Limited to span in inches (mm) divided by 180.																													
RAFTER SIZE (in)	SPACING (in)	BENDING DESIGN VALUE, $F_b$ (psi)																													
		$\times 0.00689$ for N/mm <sup>2</sup>																													
$\times 25.4$ for mm		200	300	400	500	600	700	800	900	1000	1100	1200	1300	1400	1500	1600	1700	1800	1900	2000	2100	2200	2300	2400	2500	2600	2700	2800	2900	3000	
2 x 4	12.0	3-2	3-11	4-0	5-1	5-8	6-0	6-5	6-9	7-2	7-6	7-10	8-2	8-5	8-9	8-8	8-4	8-7	8-10	10-1	10-4	10-7	10-10	11-1	11-4	11-8	11-11	12-2	12-4		
	18.0	2-0	3-5	3-11	4-4	4-10	5-2	5-8	5-10	6-2	6-6	6-9	7-1	7-4	7-7	7-10	8-1	8-4	8-8	8-8	8-8	8-2	8-5	8-7	8-8	8-8	10-0	10-2	10-4	10-6	10-8
	18.2	2-0	3-1	3-7	4-0	4-4	4-9	5-1	5-4	5-8	5-11	6-2	6-5	6-8	6-11	7-2	7-4	7-7	7-9	8-0	8-2	8-5	8-7	8-8	8-11	9-1	9-3	9-5	9-7	9-9	
	24.0	2-3	2-9	3-2	3-7	3-11	4-3	4-6	4-10	5-1	5-4	5-8	5-9	6-0	6-2	6-5	6-7	6-9	7-0	7-2	7-4	7-6	7-8	7-10	8-0	8-2	8-4	8-5	8-7	8-9	
2 x 6	12.0	6-0	6-2	7-1	7-11	8-0	8-5	10-0	10-0	11-3	11-0	12-4	12-10	13-3	13-9	14-2	14-8	15-1	15-0	15-11	16-3	16-8	17-0	17-5	17-9	18-1	18-5	18-8	18-1	18-5	18-10
	18.0	4-4	5-4	6-2	6-10	7-0	8-2	8-8	9-3	9-9	10-2	10-8	11-1	11-8	11-11	12-4	12-8	13-1	13-5	13-9	14-1	14-5	14-9	15-1	15-4	15-8	16-0	16-3	16-7	16-10	
	18.2	4-0	4-10	5-7	6-3	6-10	7-5	7-11	8-5	8-11	9-4	9-9	10-1	10-6	10-10	11-3	11-7	11-11	12-3	12-7	12-10	13-2	13-6	13-9	14-0	14-4	14-7	14-10	15-1	15-4	
	24.0	3-7	4-4	5-0	5-7	6-2	6-8	7-1	7-6	7-11	8-4	8-8	9-1	9-5	9-9	10-0	10-4	10-8	10-11	11-3	11-6	11-9	12-0	12-4	12-7	12-10	13-1	13-3	13-6	13-9	
2 x 8	12.0	8-7	8-1	8-4	10-0	11-0	12-5	13-3	14-0	14-10	15-0	16-3	16-10	17-8	18-1	18-9	18-4	18-10	20-5	20-11	21-5	21-11	22-5	22-11	23-5	23-10	24-4	24-9	25-2	25-8	
	18.0	5-0	7-0	8-1	8-1	8-11	10-0	11-8	12-2	12-10	13-5	14-0	14-7	15-2	15-8	16-3	16-9	17-2	17-8	18-1	18-7	19-0	19-5	19-10	20-3	20-8	21-1	21-5	21-10	22-2	
	18.2	5-3	6-5	7-5	8-3	8-1	9-0	10-0	11-1	11-8	12-3	12-10	13-4	13-10	14-4	14-10	15-3	15-8	16-2	16-7	16-11	17-4	17-9	18-1	18-6	18-10	19-3	19-7	19-11	20-3	
	24.0	4-8	5-9	6-7	7-5	8-1	8-9	9-4	9-11	10-8	11-0	11-9	11-11	12-5	12-10	13-3	13-8	14-0	14-5	14-10	15-2	15-6	15-10	16-3	16-7	16-10	17-2	17-6	17-10	18-1	
2 x 10	12.0	8-5	10-4	11-11	13-4	14-0	15-10	16-11	17-11	18-10	18-10	20-3	21-0	22-4	23-1	23-11	24-7	25-4	26-0												
	18.0	7-4	8-11	10-4	11-7	12-8	13-8	14-8	15-8	16-4	17-2	17-11	18-8	19-4	20-0	20-8	21-4	21-11	22-8	23-1	23-8	24-3	24-10	25-4	25-10						
	18.2	8-0	8-2	8-5	10-7	11-7	12-0	13-4	14-2	14-11	15-0	16-4	17-0	18-3	18-9	19-4	19-11	20-0	20-7	21-1	21-8	22-2	22-8	23-1	23-7	24-1	24-8	25-0	25-5	25-10	
	24.0	6-0	7-4	8-5	9-5	10-4	11-2	11-11	12-8	13-4	14-0	14-8	15-3	15-10	16-4	16-11	17-5	17-11	18-5	18-11	19-4	19-10	20-3	20-8	21-1	21-8	21-11	22-4	22-9	23-1	
E	12.0	0.94	0.96	0.12	0.16	0.21	0.27	0.33	0.38	0.46	0.53	0.60	0.65	0.70	0.74	0.83	1.02	1.11	1.20	1.30	1.40	1.50	1.60	1.71	1.82	1.93	2.04	2.15	2.27	2.38	
	18.0	0.84	0.87	0.10	0.14	0.18	0.23	0.29	0.34	0.40	0.46	0.52	0.58	0.66	0.73	0.80	0.88	0.96	1.04	1.13	1.21	1.30	1.40	1.57	1.67	1.78	1.88	1.98	2.07		
	18.2	0.83	0.86	0.09	0.13	0.17	0.21	0.26	0.31	0.36	0.42	0.48	0.54	0.60	0.67	0.73	0.80	0.88	0.95	1.03	1.10	1.18	1.27	1.35	1.44	1.52	1.61	1.70	1.79	1.88	
	24.0	0.83	0.85	0.08	0.11	0.15	0.19	0.23	0.28	0.32	0.37	0.43	0.48	0.54	0.60	0.66	0.72	0.78	0.85	0.92	0.99	1.06	1.13	1.21	1.28	1.36	1.44	1.52	1.60	1.68	

2-931

**NOTE:** The required modulus of elasticity,  $E$ , in 1,000,000 pounds per square inch (psi) ( $\times 0.00689$  for N/mm<sup>2</sup>) is shown at the bottom of this table, is limited to 2.6 million psi (17 914 N/mm<sup>2</sup>) and less, and is applicable to all lumber sizes shown. Spans are shown in feet-inches (1 foot = 304.8 mm, 1 inch = 25.4 mm) and are limited to 26 feet (7925 mm) and less.

**TABLE 23-I-V-R-12—RAFTERS WITH L/180 DEFLECTION LIMITATION**

The allowable bending stress ( $F_b$ ) and modulus of elasticity ( $E$ ) used in this table shall be from Tables 23-I-X-1 and 23-I-X-2 only.

DESIGN CRITERIA:																														
Strength — Live load of 30 psf (1.44 kN/m <sup>2</sup> ) plus dead load of 20 psf (0.96 kN/m <sup>2</sup> ) determines the required bending design value.		Deflection — For 30 psf (1.44 kN/m <sup>2</sup> ) live load. Limited to span in inches (mm) divided by 180.																												
RAFTER SIZE (in)	SPACING (in)	BENDING DESIGN VALUE, $F_b$ (psi)																												
		× 0.00689 for N/mm <sup>2</sup>																												
× 25.4 mm		200	300	400	500	600	700	800	900	1000	1100	1200	1300	1400	1500	1600	1700	1800	1900	2000	2100	2200	2300	2400	2500	2600	2700	2800	2900	3000
2x4	12.0	2-10	3-0	4-0	4-6	4-11	5-4	5-8	6-1	6-5	6-8	7-0	7-3	7-7	7-10	8-1	8-4	8-7	8-10	9-0	9-3	9-6	9-8	9-11	10-1	10-4	10-8	10-8	10-11	11-1
	16.0	2-0	3-0	3-0	3-11	4-3	4-8	4-11	5-3	5-6	5-10	6-1	6-4	6-7	6-9	7-0	7-3	7-5	7-8	7-10	8-0	8-2	8-5	8-7	8-9	8-11	9-1	9-3	9-5	9-7
	18.2	2-3	2-8	3-2	3-7	3-11	4-3	4-8	4-10	5-1	5-4	5-8	5-9	6-0	6-2	6-5	6-7	6-9	7-0	7-2	7-4	7-6	7-8	7-10	8-0	8-2	8-4	8-5	8-7	8-9
	24.0	2-0	2-0	2-10	3-2	3-8	3-8	4-0	4-3	4-6	4-8	4-11	5-2	5-4	5-6	5-9	5-11	6-1	6-3	6-5	6-7	6-8	6-10	7-0	7-2	7-3	7-5	7-7	7-8	7-10
2x6	12.0	4-0	5-0	6-4	7-1	7-9	8-5	9-0	9-0	10-0	10-0	11-0	11-5	11-11	12-4	12-8	13-1	13-6	13-10	14-2	14-7	14-11	15-3	15-7	15-11	16-2	16-8	16-10	17-1	17-5
	16.0	3-11	4-9	5-6	6-2	6-9	7-3	7-9	8-3	8-8	9-1	9-8	9-11	10-3	10-8	11-0	11-4	11-8	12-0	12-4	12-7	12-11	13-2	13-6	13-9	14-0	14-3	14-7	14-10	15-1
	18.2	3-7	4-4	5-0	5-7	6-2	6-8	7-1	7-8	7-11	8-4	8-8	9-1	9-5	9-9	10-0	10-4	10-8	10-11	11-3	11-6	11-9	12-0	12-4	12-7	12-10	13-1	13-3	13-6	13-8
	24.0	3-2	3-11	4-6	5-0	5-8	5-11	6-4	6-9	7-1	7-5	7-9	8-1	8-5	8-8	9-0	9-3	9-6	9-9	10-0	10-3	10-6	10-9	11-0	11-3	11-5	11-8	11-11	12-1	12-4
2x8	12.0	5-11	7-3	8-4	8-4	10-3	11-1	11-10	12-7	13-3	13-11	14-0	15-1	15-8	16-3	16-8	17-3	17-8	18-3	19-0	19-2	19-8	20-1	20-8	20-11	21-4	21-8	22-2	22-8	22-11
	16.0	5-2	6-3	7-3	8-1	8-11	9-7	10-3	10-10	11-0	12-0	12-7	13-1	13-7	14-0	14-6	14-11	15-5	15-10	16-3	16-7	17-0	17-5	17-9	18-1	18-6	18-10	19-2	19-8	19-10
	18.2	4-8	5-9	6-7	7-5	8-1	8-9	9-4	9-11	10-0	11-0	11-0	11-11	12-5	12-10	13-3	13-8	14-0	14-5	14-10	15-2	15-6	15-10	16-3	16-7	16-10	17-2	17-8	17-10	18-1
	24.0	4-2	5-2	5-11	6-7	7-3	7-10	8-4	8-11	9-4	9-10	10-3	10-8	11-1	11-6	11-10	12-2	12-7	12-11	13-3	13-7	13-11	14-2	14-6	14-10	15-1	15-5	15-8	15-11	16-3
2x10	12.0	7-7	8-3	10-8	11-11	13-1	14-2	15-1	16-0	16-11	17-9	18-0	19-3	20-0	20-8	21-4	22-0	22-8	23-3	23-11	24-0	25-1	25-7							
	16.0	6-0	6-0	8-3	10-4	11-4	12-3	13-1	13-10	14-0	15-4	16-0	16-8	17-4	17-11	18-0	18-1	18-7	20-2	20-8	21-2	21-8	22-2	22-8	23-1	23-7	24-0	24-0	24-11	25-4
	18.2	6-0	7-4	8-5	9-5	10-4	11-2	11-11	12-8	13-4	14-0	14-8	15-3	15-10	16-4	16-11	17-5	17-11	18-5	18-11	19-4	19-10	20-3	20-8	21-1	21-6	21-11	22-4	22-8	23-1
	24.0	5-4	6-0	7-7	8-5	9-3	10-0	10-8	11-4	11-11	12-8	13-1	13-7	14-2	14-8	15-1	15-7	16-0	16-6	16-11	17-4	17-9	18-1	18-6	18-11	19-3	19-7	20-0	20-4	20-8
E	12.0	0.94	0.90	0.12	0.17	0.23	0.29	0.35	0.42	0.48	0.57	0.65	0.73	0.82	0.91	1.00	1.09	1.18	1.29	1.39	1.50	1.61	1.72	1.83	1.95	2.07	2.18	2.31	2.43	2.56
	16.0	0.94	0.87	0.11	0.15	0.20	0.25	0.31	0.38	0.45	0.53	0.62	0.71	0.79	0.88	0.95	1.03	1.12	1.21	1.30	1.39	1.49	1.59	1.69	1.79	1.89	2.00	2.11	2.22	
	18.2	0.93	0.86	0.10	0.14	0.18	0.23	0.28	0.33	0.39	0.45	0.51	0.58	0.65	0.72	0.79	0.86	0.94	1.02	1.10	1.19	1.27	1.36	1.45	1.54	1.63	1.73	1.83	1.92	2.03
	24.0	0.93	0.86	0.09	0.12	0.16	0.20	0.25	0.30	0.35	0.40	0.46	0.52	0.58	0.64	0.71	0.77	0.84	0.91	0.99	1.06	1.14	1.22	1.30	1.38	1.46	1.55	1.63	1.72	1.81

**NOTE:** The required modulus of elasticity,  $E$ , in 1,000,000 pounds per square inch (psi) (× 0.00689 for N/mm<sup>2</sup>) is shown at the bottom of this table, is limited to 2.6 million psi (17 914 N/mm<sup>2</sup>) and less, and is applicable to all lumber sizes shown. Spans are shown in feet-inches (1 foot = 304.8 mm, 1 inch = 25.4 mm) and are limited to 26 feet (7925 mm) and less.

**TABLE 23-I-W—BRACED WALL PANELS<sup>1</sup>**

SEISMIC ZONE	CONDITION	CONSTRUCTION METHOD <sup>2,3</sup>								BRACED PANEL LOCATION AND LENGTH <sup>4</sup>
		1	2	3	4	5	6	7	8	
0, 1 and 2A	One story, top of two or three story	X	X	X	X	X	X	X	X	Each end and not more than 25 feet (7620 mm) on center
	First story of two story or second story of three story	X	X	X	X	X	X	X	X	
	First story of three story		X	X	X	X <sup>5</sup>	X	X	X	
2B, 3 and 4	One story, top of two or three story		X	X	X	X	X	X	X	Each end and not more than 25 feet (7620 mm) on center
	First story of two story or second of three story		X	X	X	X <sup>5</sup>	X	X	X	Each end and not more than 25 feet (7620 mm) on center but not less than 25% of building length <sup>6</sup>
	First story of three story		X	X	X	X <sup>5</sup>	X	X	X	Each end and not more than 25 feet (7620 mm) on center but not less than 40% of building length <sup>6</sup>

<sup>1</sup>This table specifies minimum requirements for braced panels which form interior or exterior braced wall lines.

<sup>2</sup>See Section 2326.11.3 for full description.

<sup>3</sup>See Section 2326.11.4 for alternate braced panel requirement.

<sup>4</sup>Building length is the dimension parallel to the braced wall length.

<sup>5</sup>Gypsum wallboard applied to supports at 16 inches (406 mm) on center.

<sup>6</sup>The required lengths shall be doubled for gypsum board applied to only one face of a braced wall panel.

**TABLE 23-I-X-1—VALUES FOR JOISTS AND RAFTERS—VISUALLY GRADED LUMBER**  
**For Use in Tables 23-I-V-J-1 through 23-I-V-R-12 and Chapter 23, Division V only.**

These " $F_b$ " values are for use where repetitive members are spaced not more than 24 inches (610 mm). For wider spacing, the " $F_b$ " values shall be reduced 13 percent.  
 Values for surfaced dry or surfaced green lumber apply at 19 percent maximum moisture content in use.

SPECIES AND GRADE	SIZE (Inches) × 25.4 for mm	DESIGN VALUE IN BENDING " $F_b$ " psi			MODULUS OF ELASTICITY " $E$ " psi	GRADING RULES AGENCY
		Normal Duration	Snow Loading	7-day Loading		
		× 0.00689 for N/mm <sup>2</sup>				
<b>ASPEN</b>						
Select Structural	2×4	1,510	1,735	1,885	1,100,000	NELMA NSLB WWPA
No. 1		1,080	1,240	1,350	1,100,000	
No. 2		1,035	1,190	1,295	1,000,000	
No. 3		605	695	755	900,000	
Stud		600	690	750	900,000	
Construction		805	925	1,005	900,000	
Standard		430	495	540	900,000	
Utility		200	230	250	800,000	
Select Structural	2×6	1,310	1,505	1,635	1,100,000	
No. 1		935	1,075	1,170	1,100,000	
No. 2		895	1,030	1,120	1,000,000	
No. 3		525	600	655	900,000	
Stud		545	630	685	900,000	
Select Structural	2×8	1,210	1,390	1,510	1,100,000	
No. 1		865	990	1,080	1,100,000	
No. 2		830	950	1,035	1,000,000	
No. 3		485	555	605	900,000	
Select Structural	2×10	1,105	1,275	1,385	1,100,000	
No. 1		790	910	990	1,100,000	
No. 2		760	875	950	1,000,000	
No. 3		445	510	555	900,000	
Select Structural	2×12	1,005	1,155	1,260	1,100,000	
No. 1		720	825	900	1,100,000	
No. 2		690	795	865	1,000,000	
No. 3		405	465	505	900,000	
<b>BEECH-BIRCH-HICKORY</b>						
Select Structural	2×4	2,500	2,875	3,125	1,700,000	NELMA
No. 1		1,810	2,085	2,265	1,600,000	
No. 2		1,725	1,985	2,155	1,500,000	
No. 3		990	1,140	1,240	1,300,000	
Stud		980	1,125	1,225	1,300,000	
Construction		1,325	1,520	1,655	1,400,000	
Standard		750	860	935	1,300,000	
Utility		345	395	430	1,200,000	
Select Structural	2×6	2,170	2,495	2,710	1,700,000	
No. 1		1,570	1,805	1,960	1,600,000	
No. 2		1,495	1,720	1,870	1,500,000	
No. 3		860	990	1,075	1,300,000	
Stud		890	1,025	1,115	1,300,000	

(Continued)

**TABLE 23-I-X-1—VALUES FOR JOISTS AND RAFTERS—VISUALLY GRADED LUMBER—(Continued)**

SPECIES AND GRADE	SIZE (Inches) × 25.4 for mm	DESIGN VALUE IN BENDING "F <sub>b</sub> " psi			MODULUS OF ELASTICITY "E" psi	GRADING RULES AGENCY
		Normal Duration	Snow Loading	7-day Loading		
		× 0.00689 for N/mm <sup>2</sup>				
<b>BEECH-BIRCH-HICKORY—(continued)</b>						
Select Structural	2×8	2,000	2,300	2,500	1,700,000	NELMA
No. 1		1,450	1,665	1,810	1,600,000	
No. 2		1,380	1,585	1,725	1,500,000	
No. 3		795	915	990	1,300,000	
Select Structural	2×10	1,835	2,110	2,295	1,700,000	
No. 1		1,330	1,525	1,660	1,600,000	
No. 2		1,265	1,455	1,580	1,500,000	
No. 3		725	835	910	1,300,000	
Select Structural	2×12	1,670	1,920	2,085	1,700,000	
No. 1		1,210	1,390	1,510	1,600,000	
No. 2		1,150	1,325	1,440	1,500,000	
No. 3		660	760	825	1,300,000	
<b>COTTONWOOD</b>						
Select Structural	2×4	1,510	1,735	1,885	1,200,000	NSLB
No. 1		1,080	1,240	1,350	1,200,000	
No. 2		1,080	1,240	1,350	1,100,000	
No. 3		605	695	755	1,000,000	
Stud		600	690	750	1,000,000	
Construction		805	925	1,005	1,000,000	
Standard		460	530	575	900,000	
Utility		200	230	250	900,000	
Select Structural	2×6	1,310	1,505	1,635	1,200,000	
No. 1		935	1,075	1,170	1,200,000	
No. 2		935	1,075	1,170	1,100,000	
No. 3		525	600	655	1,000,000	
Stud		545	630	685	1,000,000	
Select Structural	2×8	1,210	1,390	1,510	1,200,000	
No. 1		865	990	1,080	1,200,000	
No. 2		865	990	1,080	1,100,000	
No. 3		485	555	605	1,000,000	
Select Structural	2×10	1,105	1,275	1,385	1,200,000	
No. 1		790	910	990	1,200,000	
No. 2		790	910	990	1,100,000	
No. 3		445	510	555	1,000,000	
Select Structural	2×12	1,005	1,155	1,260	1,200,000	
No. 1		720	825	900	1,200,000	
No. 2		720	825	900	1,100,000	
No. 3		405	465	505	1,000,000	

**TABLE 23-I-X-1—VALUES FOR JOISTS AND RAFTERS—VISUALLY GRADED LUMBER—(Continued)**

SPECIES AND GRADE	SIZE (Inches) × 25.4 for mm	DESIGN VALUE IN BENDING "F <sub>b</sub> " psi			MODULUS OF ELASTICITY "E" psi	GRADING RULES AGENCY
		Normal Duration	Snow Loading	7-day Loading		
		× 0.00689 for N/mm <sup>2</sup>				
<b>DOUGLAS FIR-LARCH</b>						
Select Structural	2×4	2,500	2,875	3,125	1,900,000	WCLIB WWPA
No. 1 and better		1,985	2,280	2,480	1,800,000	
No. 1		1,725	1,985	2,155	1,700,000	
No. 2		1,510	1,735	1,885	1,600,000	
No. 3		865	990	1,080	1,400,000	
Stud		855	980	1,065	1,400,000	
Construction		1,150	1,325	1,440	1,500,000	
Standard		635	725	790	1,400,000	
Utility	315	365	395	1,300,000		
Select Structural	2×6	2,170	2,495	2,710	1,900,000	
No. 1 and better		1,720	1,975	2,150	1,800,000	
No. 1		1,495	1,720	1,870	1,700,000	
No. 2		1,310	1,505	1,635	1,600,000	
No. 3		750	860	935	1,400,000	
Stud		775	895	970	1,400,000	
Select Structural	2×8	2,000	2,300	2,500	1,900,000	
No. 1 and better		1,585	1,825	1,985	1,800,000	
No. 1		1,380	1,585	1,725	1,700,000	
No. 2		1,210	1,390	1,510	1,600,000	
No. 3		690	795	865	1,400,000	
Select Structural	2×10	1,835	2,110	2,295	1,900,000	
No. 1 and better		1,455	1,675	1,820	1,800,000	
No. 1		1,265	1,455	1,580	1,700,000	
No. 2		1,105	1,275	1,385	1,600,000	
No. 3		635	725	790	1,400,000	
Select Structural	2×12	1,670	1,920	2,085	1,900,000	
No. 1 and better		1,325	1,520	1,655	1,800,000	
No. 1		1,150	1,325	1,440	1,700,000	
No. 2		1,005	1,155	1,260	1,600,000	
No. 3		575	660	720	1,400,000	
<b>DOUGLAS FIR-LARCH (North)</b>						
Select Structural	2×4	2,245	2,580	2,805	1,900,000	NLGA
No. 1/No. 2		1,425	1,635	1,780	1,600,000	
No. 3		820	940	1,025	1,400,000	
Stud		820	945	1,030	1,400,000	
Construction		1,095	1,255	1,365	1,500,000	
Standard		605	695	755	1,400,000	
Utility		290	330	360	1,300,000	
Select Structural	2×6	1,945	2,235	2,430	1,900,000	
No. 1/No. 2		1,235	1,420	1,540	1,600,000	
No. 3		710	815	890	1,400,000	
Stud		750	860	935	1,400,000	

(Continued)

**TABLE 23-I-X-1—VALUES FOR JOISTS AND RAFTERS—VISUALLY GRADED LUMBER—(Continued)**

SPECIES AND GRADE	SIZE (Inches) × 25.4 for mm	DESIGN VALUE IN BENDING "F <sub>b</sub> " psi			MODULUS OF ELASTICITY "E" psi	GRADING RULES AGENCY
		Normal Duration	Snow Loading	7-day Loading		
<b>DOUGLAS FIR-LARCH (North)—(continued)</b>						
Select Structural	2×8	1,795	2,065	2,245	1,900,000	NLGA
No. 1/No. 2		1,140	1,310	1,425	1,600,000	
No. 3		655	755	820	1,400,000	
Select Structural	2×10	1,645	1,890	2,055	1,900,000	
No. 1/No. 2		1,045	1,200	1,305	1,600,000	
No. 3		600	690	750	1,400,000	
Select Structural	2×12	1,495	1,720	1,870	1,900,000	
No. 1/No. 2		950	1,090	1,185	1,600,000	
No. 3		545	630	685	1,400,000	
<b>DOUGLAS FIR (South)</b>						
Select Structural	2×4	2,245	2,580	2,805	1,400,000	WWPA
No. 1		1,555	1,785	1,940	1,300,000	
No. 2		1,425	1,635	1,780	1,200,000	
No. 3		820	940	1,025	1,100,000	
Stud		820	945	1,030	1,100,000	
Construction		1,065	1,225	1,330	1,200,000	
Standard		605	695	755	1,100,000	
Utility		290	330	360	1,000,000	
Select Structural	2×6	1,945	2,235	2,430	1,400,000	
No. 1		1,345	1,545	1,680	1,300,000	
No. 2		1,235	1,420	1,540	1,200,000	
No. 3		710	815	890	1,100,000	
Stud		750	860	935	1,100,000	
Select Structural	2×8	1,795	2,065	2,245	1,400,000	
No. 1		1,240	1,430	1,555	1,300,000	
No. 2		1,140	1,310	1,425	1,200,000	
No. 3		655	755	820	1,100,000	
Select Structural	2×10	1,645	1,890	2,055	1,400,000	
No. 1		1,140	1,310	1,425	1,300,000	
No. 2		1,045	1,200	1,305	1,200,000	
No. 3		600	690	750	1,100,000	
Select Structural	2×12	1,495	1,720	1,870	1,400,000	
No. 1		1,035	1,190	1,295	1,300,000	
No. 2		950	1,090	1,185	1,200,000	
No. 3		545	630	685	1,100,000	

**TABLE 23-I-X-1—VALUES FOR JOISTS AND RAFTERS—VISUALLY GRADED  
LUMBER—(Continued)**

SPECIES AND GRADE	SIZE (Inches) × 25.4 for mm	DESIGN VALUE IN BENDING "F <sub>b</sub> " psi			MODULUS OF ELASTICITY "E" psi	GRADING RULES AGENCY
		Normal Duration	Snow Loading	7-day Loading		
		× 0.00689 for N/mm <sup>2</sup>				
<b>EASTERN HEMLOCK—TAMARACK</b>						
Select Structural	2×4	2,155	2,480	2,695	1,200,000	NELMA NSLB
No. 1		1,335	1,535	1,670	1,100,000	
No. 2		990	1,140	1,240	1,100,000	
No. 3		605	695	755	900,000	
Stud		570	655	710	900,000	
Construction		775	895	970	1,000,000	
Standard		430	495	540	900,000	
Utility		200	230	250	800,000	
Select Structural	2×6	1,870	2,150	2,335	1,200,000	
No. 1		1,160	1,330	1,450	1,100,000	
No. 2		860	990	1,075	1,100,000	
No. 3		525	600	655	900,000	
Stud		520	595	645	900,000	
Select Structural	2×8	1,725	1,985	2,155	1,200,000	
No. 1		1,070	1,230	1,335	1,100,000	
No. 2		795	915	990	1,100,000	
No. 3		485	555	605	900,000	
Select Structural	2×10	1,580	1,820	1,975	1,200,000	
No. 1		980	1,125	1,225	1,100,000	
No. 2		725	835	910	1,100,000	
No. 3		445	510	555	900,000	
Select Structural	2×12	1,440	1,655	1,795	1,200,000	
No. 1		890	1,025	1,115	1,100,000	
No. 2		660	760	825	1,100,000	
No. 3		405	465	505	900,000	
<b>EASTERN SOFTWOODS</b>						
Select Structural	2×4	2,155	2,480	2,695	1,200,000	NELMA NSLB
No. 1		1,335	1,535	1,670	1,100,000	
No. 2		990	1,140	1,240	1,100,000	
No. 3		605	695	755	900,000	
Stud		570	655	710	900,000	
Construction		775	895	970	1,000,000	
Standard		430	495	540	900,000	
Utility		200	230	250	800,000	
Select Structural	2×6	1,870	2,150	2,335	1,200,000	
No. 1		1,160	1,330	1,450	1,100,000	
No. 2		860	990	1,075	1,100,000	
No. 3		525	600	655	900,000	
Stud		520	595	645	900,000	

(Continued)

**TABLE 23-I-X-1—VALUES FOR JOISTS AND RAFTERS—VISUALLY GRADED LUMBER—(Continued)**

SPECIES AND GRADE	SIZE (Inches) × 25.4 for mm	DESIGN VALUE IN BENDING "F <sub>b</sub> " psi			MODULUS OF ELASTICITY "E" psi	GRADING RULES AGENCY
		Normal Duration	Snow Loading	7-day Loading		
		× 0.00689 for N/mm <sup>2</sup>				
<b>EASTERN SOFTWOODS—(continued)</b>						
Select Structural	2×8	1,725	1,985	2,155	1,200,000	NELMA NSLB
No. 1		1,070	1,230	1,335	1,100,000	
No. 2		795	915	990	1,100,000	
No. 3		485	555	605	900,000	
Select Structural	2×10	1,580	1,820	1,975	1,200,000	
No. 1		980	1,125	1,225	1,100,000	
No. 2		725	835	910	1,100,000	
No. 3		445	510	555	900,000	
Select Structural	2×12	1,440	1,655	1,795	1,200,000	
No. 1		890	1,025	1,115	1,100,000	
No. 2		660	760	825	1,100,000	
No. 3		405	465	505	900,000	
<b>EASTERN WHITE PINE</b>						
Select Structural	2×4	2,155	2,480	2,695	1,200,000	NELMA NSLB
No. 1		1,335	1,535	1,670	1,100,000	
No. 2		990	1,140	1,240	1,100,000	
No. 3		605	695	755	900,000	
Stud		570	655	710	900,000	
Construction		775	895	970	1,000,000	
Standard		430	495	540	900,000	
Utility		200	230	250	800,000	
Select Structural	2×6	1,870	2,150	2,335	1,200,000	
No. 1		1,160	1,330	1,450	1,100,000	
No. 2		860	990	1,075	1,100,000	
No. 3		525	600	655	900,000	
Stud		520	595	645	900,000	
Select Structural	2×8	1,725	1,985	2,155	1,200,000	
No. 1		1,070	1,230	1,335	1,100,000	
No. 2		795	915	990	1,100,000	
No. 3		485	555	605	900,000	
Select Structural	2×10	1,580	1,820	1,975	1,200,000	
No. 1		980	1,125	1,225	1,100,000	
No. 2		725	835	910	1,100,000	
No. 3		445	510	555	900,000	
Select Structural	2×12	1,440	1,655	1,795	1,200,000	
No. 1		890	1,025	1,115	1,100,000	
No. 2		660	760	825	1,100,000	
No. 3		405	465	505	900,000	

**TABLE 23-I-X-1—VALUES FOR JOISTS AND RAFTERS—VISUALLY GRADED  
LUMBER—(Continued)**

SPECIES AND GRADE	SIZE (Inches) × 25.4 for mm	DESIGN VALUE IN BENDING "F <sub>b</sub> " psi			MODULUS OF ELASTICITY "E" psi	GRADING RULES AGENCY
		Normal Duration	Snow Loading	7-day Loading		
		× 0.00689 for N/mm <sup>2</sup>				
<b>HEM-FIR</b>						
Select Structural	2×4	2,415	2,775	3,020	1,600,000	WCLIB WWPA
No. 1 and better		1,810	2,085	2,265	1,500,000	
No. 1		1,640	1,885	2,050	1,500,000	
No. 2		1,465	1,685	1,835	1,300,000	
No. 3		865	990	1,080	1,200,000	
Stud		855	980	1,065	1,200,000	
Construction		1,120	1,290	1,400	1,300,000	
Standard		635	725	790	1,200,000	
Utility		290	330	360	1,100,000	
Select Structural	2×6	2,095	2,405	2,615	1,600,000	
No. 1 and better		1,570	1,805	1,960	1,500,000	
No. 1		1,420	1,635	1,775	1,500,000	
No. 2		1,270	1,460	1,590	1,300,000	
No. 3		750	860	935	1,200,000	
Stud		775	895	970	1,200,000	
Select Structural	2×8	1,930	2,220	2,415	1,600,000	
No. 1 and better		1,450	1,665	1,810	1,500,000	
No. 1		1,310	1,510	1,640	1,500,000	
No. 2		1,175	1,350	1,465	1,300,000	
No. 3	690	795	865	1,200,000		
Select Structural	2×10	1,770	2,035	2,215	1,600,000	
No. 1 and better		1,330	1,525	1,660	1,500,000	
No. 1		1,200	1,380	1,500	1,500,000	
No. 2		1,075	1,235	1,345	1,300,000	
No. 3		635	725	790	1,200,000	
Select Structural	2×12	1,610	1,850	2,015	1,600,000	
No. 1 and better		1,210	1,390	1,510	1,500,000	
No. 1		1,095	1,255	1,365	1,500,000	
No. 2		980	1,125	1,220	1,300,000	
No. 3	575	660	720	1,200,000		
<b>HEM-FIR (North)</b>						
Select Structural	2×4	2,245	2,580	2,805	1,700,000	NLGA
No. 1/No. 2		1,725	1,985	2,155	1,600,000	
No. 3		990	1,140	1,240	1,400,000	
Stud		980	1,125	1,225	1,400,000	
Construction		1,325	1,520	1,655	1,500,000	
Standard		720	825	900	1,400,000	
Utility		345	395	430	1,300,000	
Select Structural	2×6	1,945	2,235	2,430	1,700,000	
No. 1/No. 2		1,495	1,720	1,870	1,600,000	
No. 3		860	990	1,075	1,400,000	
Stud		890	1,025	1,115	1,400,000	

(Continued)

**TABLE 23-I-X-1—VALUES FOR JOISTS AND RAFTERS—VISUALLY GRADED LUMBER—(Continued)**

SPECIES AND GRADE	SIZE (inches) × 25.4 for mm	DESIGN VALUE IN BENDING "F <sub>b</sub> " psi			MODULUS OF ELASTICITY "E" psi	GRADING RULES AGENCY
		Normal Duration	Snow Loading	7-day Loading		
		× 0.00689 for N/mm <sup>2</sup>				
<b>HEM-FIR (North)—(continued)</b>						
Select Structural	2×8	1,795	2,065	2,245	1,700,000	NLGA
No. 1/No. 2		1,380	1,585	1,725	1,600,000	
No. 3		795	915	990	1,400,000	
Select Structural	2×10	1,645	1,890	2,055	1,700,000	
No. 1/No. 2		1,265	1,455	1,580	1,600,000	
No. 3		725	835	910	1,400,000	
Select Structural	2×12	1,495	1,720	1,870	1,700,000	
No. 1/No. 2		1,150	1,325	1,440	1,600,000	
No. 3		660	760	825	1,400,000	
<b>MIXED MAPLE</b>						
Select Structural	2×4	1,725	1,985	2,155	1,300,000	NELMA
No. 1		1,250	1,440	1,565	1,200,000	
No. 2		1,210	1,390	1,510	1,100,000	
No. 3		690	795	865	1,000,000	
Stud		695	800	870	1,000,000	
Construction		920	1,060	1,150	1,100,000	
Standard		520	595	645	1,000,000	
Utility		260	300	325	900,000	
Select Structural	2×6	1,495	1,720	1,870	1,300,000	
No. 1		1,085	1,245	1,355	1,200,000	
No. 2		1,045	1,205	1,310	1,100,000	
No. 3		600	690	750	1,000,000	
Stud		635	725	790	1,000,000	
Select Structural	2×8	1,380	1,585	1,725	1,300,000	
No. 1		1,000	1,150	1,250	1,200,000	
No. 2		965	1,110	1,210	1,100,000	
No. 3		550	635	690	1,000,000	
Select Structural	2×10	1,265	1,455	1,580	1,300,000	
No. 1		915	1,055	1,145	1,200,000	
No. 2		885	1,020	1,105	1,100,000	
No. 3		505	580	635	1,000,000	
Select Structural	2×12	1,150	1,325	1,440	1,300,000	
No. 1		835	960	1,040	1,200,000	
No. 2		805	925	1,005	1,100,000	
No. 3		460	530	575	1,000,000	
<b>MIXED OAK</b>						
Select Structural	2×4	1,985	2,280	2,480	1,100,000	NELMA
No. 1		1,425	1,635	1,780	1,000,000	
No. 2		1,380	1,585	1,725	900,000	
No. 3		820	940	1,025	800,000	
Stud		790	910	990	800,000	
Construction		1,065	1,225	1,330	900,000	
Standard		605	695	755	800,000	
Utility		290	330	360	800,000	

**TABLE 23-I-X-1—VALUES FOR JOISTS AND RAFTERS—VISUALLY GRADED LUMBER—(Continued)**

SPECIES AND GRADE	SIZE (inches) × 25.4 for mm	DESIGN VALUE IN BENDING "F <sub>b</sub> " psi			MODULUS OF ELASTICITY "E" psi × 0.00689 for N/mm <sup>2</sup>	GRADING RULES AGENCY
		Normal Duration	Snow Loading	7-day Loading		
<b>MIXED OAK—(continued)</b>						
Select Structural	2×6	1,720	1,975	2,150	1,100,000	NELMA
No. 1		1,235	1,420	1,540	1,000,000	
No. 2		1,195	1,375	1,495	900,000	
No. 3		710	815	890	800,000	
Stud		720	825	900	800,000	
Select Structural	2×8	1,585	1,825	1,985	1,100,000	
No. 1		1,140	1,310	1,425	1,000,000	
No. 2		1,105	1,270	1,380	900,000	
No. 3	655	755	820	800,000		
Select Structural	2×10	1,455	1,675	1,820	1,100,000	
No. 1		1,045	1,200	1,305	1,000,000	
No. 2		1,010	1,165	1,265	900,000	
No. 3		600	690	750	800,000	
Select Structural	2×12	1,325	1,520	1,655	1,100,000	
No. 1		950	1,090	1,185	1,000,000	
No. 2		920	1,060	1,150	900,000	
No. 3		545	630	685	800,000	
<b>MIXED SOUTHERN PINE</b>						
Select Structural	2×4	2,360	2,710	2,950	1,600,000	SPIB
No. 1		1,670	1,920	2,080	1,500,000	
No. 2		1,500	1,720	1,870	1,400,000	
No. 3		865	990	1,080	1,200,000	
Stud		890	1,020	1,110	1,200,000	
Construction		1,150	1,320	1,440	1,300,000	
Standard		635	725	790	1,200,000	
Utility	315	365	395	1,100,000		
Select Structural	2×6	2,130	2,450	2,660	1,600,000	
No. 1		1,490	1,720	1,870	1,500,000	
No. 2		1,320	1,520	1,650	1,400,000	
No. 3		775	895	970	1,200,000	
Stud	775	895	970	1,200,000		
Select Structural	2×8	2,010	2,310	2,520	1,600,000	
No. 1		1,380	1,590	1,720	1,500,000	
No. 2		1,210	1,390	1,510	1,400,000	
No. 3	720	825	900	1,200,000		
Select Structural	2×10	1,730	1,980	2,160	1,600,000	
No. 1		1,210	1,390	1,510	1,500,000	
No. 2		1,060	1,220	1,330	1,400,000	
No. 3	605	695	755	1,200,000		
Select Structural	2×12	1,610	1,850	2,010	1,600,000	
No. 1		1,120	1,290	1,400	1,500,000	
No. 2		1,010	1,160	1,260	1,400,000	
No. 3		575	660	720	1,200,000	

(Continued)

**TABLE 23-I-X-1—VALUES FOR JOISTS AND RAFTERS—VISUALLY GRADED LUMBER—(Continued)**

SPECIES AND GRADE	SIZE (Inches) × 25.4 for mm	DESIGN VALUE IN BENDING "F <sub>b</sub> " psi			MODULUS OF ELASTICITY "E" psi	GRADING RULES AGENCY
		Normal Duration	Snow Loading	7-day Loading		
		× 0.00689 for N/mm <sup>2</sup>				
<b>NORTHERN RED OAK</b>						
Select Structural	2×4	2,415	2,775	3,020	1,400,000	NELMA
No. 1		1,725	1,985	2,155	1,400,000	
No. 2		1,680	1,935	2,100	1,300,000	
No. 3		950	1,090	1,185	1,200,000	
Stud		950	1,090	1,185	1,200,000	
Construction		1,265	1,455	1,580	1,200,000	
Standard		720	825	900	1,100,000	
Utility		345	395	430	1,000,000	
Select Structural	2×6	2,095	2,405	2,615	1,400,000	
No. 1		1,495	1,720	1,870	1,400,000	
No. 2		1,460	1,675	1,820	1,300,000	
No. 3		820	945	1,030	1,200,000	
Stud		865	990	1,080	1,200,000	
Select Structural	2×8	1,930	2,220	2,415	1,400,000	
No. 1		1,380	1,585	1,725	1,400,000	
No. 2		1,345	1,545	1,680	1,300,000	
No. 3		760	875	950	1,200,000	
Select Structural	2×10	1,770	2,035	2,215	1,400,000	
No. 1		1,265	1,455	1,580	1,400,000	
No. 2		1,235	1,420	1,540	1,300,000	
No. 3		695	800	870	1,200,000	
Select Structural	2×12	1,610	1,850	2,015	1,400,000	
No. 1		1,150	1,325	1,440	1,400,000	
No. 2		1,120	1,290	1,400	1,300,000	
No. 3		635	725	790	1,200,000	
<b>NORTHERN SPECIES</b>						
Select Structural	2×4	1,640	1,885	2,050	1,100,000	NLGA
No. 1/No. 2		990	1,140	1,240	1,100,000	
No. 3		605	695	755	1,000,000	
Stud		570	655	710	1,000,000	
Construction		775	895	970	1,000,000	
Standard		430	495	540	900,000	
Utility		200	230	250	900,000	
Select Structural		2×6	1,420	1,635	1,775	
No. 1/No. 2	860		990	1,075	1,100,000	
No. 3	525		600	655	1,000,000	
Stud	520		595	645	1,000,000	
Select Structural	2×8	1,310	1,510	1,640	1,100,000	
No. 1/No. 2		795	915	990	1,100,000	
No. 3		485	555	605	1,000,000	

**TABLE 23-I-X-1—VALUES FOR JOISTS AND RAFTERS—VISUALLY GRADED LUMBER—(Continued)**

SPECIES AND GRADE	SIZE (inches) × 25.4 for mm	DESIGN VALUE IN BENDING "F <sub>b</sub> " psi			MODULUS OF ELASTICITY "E" psi × 0.00689 for N/mm <sup>2</sup>	GRADING RULES AGENCY
		Normal Duration	Snow Loading	7-day Loading		
<b>NORTHERN SPECIES—(continued)</b>						
Select Structural	2×10	1,200	1,380	1,500	1,100,000	NLGA
No. 1/No. 2		725	835	910	1,100,000	
No. 3		445	510	555	1,000,000	
Select Structural	2×12	1,095	1,255	1,365	1,100,000	
No. 1/No. 2		660	760	825	1,100,000	
No. 3		405	465	505	1,000,000	
<b>NORTHERN WHITE CEDAR</b>						
Select Structural	2×4	1,335	1,535	1,670	800,000	NELMA
No. 1		990	1,140	1,240	700,000	
No. 2		950	1,090	1,185	700,000	
No. 3		560	645	700	600,000	
Stud		540	620	670	600,000	
Construction		720	825	900	700,000	
Standard		405	465	505	600,000	
Utility		200	230	250	600,000	
Select Structural	2×6	1,160	1,330	1,450	800,000	
No. 1		860	990	1,075	700,000	
No. 2		820	945	1,030	700,000	
No. 3		485	560	605	600,000	
Stud		490	560	610	600,000	
Select Structural	2×8	1,070	1,230	1,335	800,000	
No. 1		795	915	990	700,000	
No. 2		760	875	950	700,000	
No. 3		450	515	560	600,000	
Select Structural	2×10	980	1,125	1,225	800,000	
No. 1		725	835	910	700,000	
No. 2		695	800	870	700,000	
No. 3		410	475	515	600,000	
Select Structural	2×12	890	1,025	1,115	800,000	
No. 1		660	760	825	700,000	
No. 2		635	725	790	700,000	
No. 3		375	430	465	600,000	
<b>RED MAPLE</b>						
Select Structural	2×4	2,245	2,580	2,805	1,700,000	NELMA
No. 1		1,595	1,835	1,995	1,600,000	
No. 2		1,555	1,785	1,940	1,500,000	
No. 3		905	1,040	1,130	1,300,000	
Stud		885	1,020	1,105	1,300,000	
Construction		1,210	1,390	1,510	1,400,000	
Standard		660	760	825	1,300,000	
Utility		315	365	395	1,200,000	

(Continued)

**TABLE 23-I-X-1—VALUES FOR JOISTS AND RAFTERS—VISUALLY GRADED LUMBER—(Continued)**

SPECIES AND GRADE	SIZE (Inches) × 25.4 for mm	DESIGN VALUE IN BENDING "F <sub>b</sub> " psi			MODULUS OF ELASTICITY "E" psi	GRADING RULES AGENCY
		Normal Duration	Snow Loading	7-day Loading		
		× 0.00689 for N/mm <sup>2</sup>				
<b>RED MAPLE—(continued)</b>						
Select Structural	2×6	1,945	2,235	2,430	1,700,000	NELMA
No. 1		1,385	1,590	1,730	1,600,000	
No. 2		1,345	1,545	1,680	1,500,000	
No. 3		785	905	980	1,300,000	
Stud		805	925	1,005	1,300,000	
Select Structural	2×8	1,795	2,065	2,245	1,700,000	
No. 1		1,275	1,470	1,595	1,600,000	
No. 2		1,240	1,430	1,555	1,500,000	
No. 3		725	835	905	1,300,000	
Select Structural	2×10	1,645	1,890	2,055	1,700,000	
No. 1		1,170	1,345	1,465	1,600,000	
No. 2		1,140	1,310	1,425	1,500,000	
No. 3		665	765	830	1,300,000	
Select Structural	2×12	1,495	1,720	1,870	1,700,000	
No. 1		1,065	1,225	1,330	1,600,000	
No. 2		1,035	1,190	1,295	1,500,000	
No. 3		605	695	755	1,300,000	
<b>RED OAK</b>						
Select Structural	2×4	1,985	2,280	2,480	1,400,000	
No. 1		1,425	1,635	1,780	1,300,000	
No. 2		1,380	1,585	1,725	1,200,000	
No. 3		820	940	1,025	1,100,000	
Stud		790	910	990	1,100,000	
Construction		1,065	1,225	1,330	1,200,000	
Standard		605	695	755	1,100,000	
Utility		290	330	360	1,000,000	
Select Structural	2×6	1,720	1,975	2,150	1,400,000	
No. 1		1,235	1,420	1,540	1,300,000	
No. 2		1,195	1,375	1,495	1,200,000	
No. 3		710	815	890	1,100,000	
Stud		720	825	900	1,100,000	
Select Structural	2×8	1,585	1,825	1,985	1,400,000	
No. 1		1,140	1,310	1,425	1,300,000	
No. 2		1,105	1,270	1,380	1,200,000	
No. 3		655	755	820	1,100,000	
Select Structural	2×10	1,455	1,675	1,820	1,400,000	
No. 1		1,045	1,200	1,305	1,300,000	
No. 2		1,010	1,165	1,265	1,200,000	
No. 3		600	690	750	1,100,000	
Select Structural	2×12	1,325	1,520	1,655	1,400,000	
No. 1		950	1,090	1,185	1,300,000	
No. 2		920	1,060	1,150	1,200,000	
No. 3		545	630	685	1,100,000	

**TABLE 23-I-X-1—VALUES FOR JOISTS AND RAFTERS—VISUALLY GRADED  
LUMBER—(Continued)**

SPECIES AND GRADE	SIZE (inches) × 25.4 for mm	DESIGN VALUE IN BENDING "F <sub>b</sub> " psi			MODULUS OF ELASTICITY "E" psi	GRADING RULES AGENCY
		Normal Duration	Snow Loading	7-day Loading		
<b>REDWOOD</b>						
Clear Structural	2×4	3,020	3,470	3,775	1,400,000	RIS
Select Structural		2,330	2,680	2,910	1,400,000	
Select Structural, open grain		1,900	2,180	2,370	1,100,000	
No. 1		1,680	1,935	2,100	1,300,000	
No. 1, open grain		1,335	1,535	1,670	1,100,000	
No. 2		1,595	1,835	1,995	1,200,000	
No. 2, open grain		1,250	1,440	1,565	1,000,000	
No. 3		905	1,040	1,130	1,100,000	
No. 3, open grain		735	845	915	900,000	
Stud		725	835	910	900,000	
Construction		950	1,090	1,185	900,000	
Standard		520	595	645	900,000	
Utility		260	300	325	800,000	
Clear Structural	2×6	2,615	3,010	3,270	1,400,000	RIS
Select Structural		2,020	2,320	2,525	1,400,000	
Select Structural, open grain		1,645	1,890	2,055	1,100,000	
No. 1		1,460	1,675	1,820	1,300,000	
No. 1, open grain		1,160	1,330	1,450	1,100,000	
No. 2		1,385	1,590	1,730	1,200,000	
No. 2, open grain		1,085	1,245	1,355	1,000,000	
No. 3		785	905	980	1,100,000	
No. 3, open grain	635	730	795	900,000		
Stud	660	760	825	900,000		
Clear Structural	2×8	2,415	2,775	3,020	1,400,000	RIS
Select Structural		1,865	2,140	2,330	1,400,000	
Select Structural, open grain		1,520	1,745	1,900	1,100,000	
No. 1		1,345	1,545	1,680	1,300,000	
No. 1, open grain		1,070	1,230	1,335	1,100,000	
No. 2		1,275	1,470	1,595	1,200,000	
No. 2, open grain		1,000	1,150	1,250	1,000,000	
No. 3		725	835	905	1,100,000	
No. 3, open grain	585	675	735	900,000		

(Continued)

**TABLE 23-I-X-1—VALUES FOR JOISTS AND RAFTERS—VISUALLY GRADED LUMBER—(Continued)**

SPECIES AND GRADE	SIZE (Inches) × 25.4 for mm	DESIGN VALUE IN BENDING "F <sub>b</sub> " psi			MODULUS OF ELASTICITY "E" psi	GRADING RULES AGENCY
		Normal Duration	Snow Loading	7-day Loading		
<b>REDWOOD—(continued)</b>						
Clear Structural	2×10	2,215	2,545	2,765	1,400,000	RIS
Select Structural		1,710	1,965	2,135	1,400,000	
Select Structural, open grain		1,390	1,600	1,740	1,100,000	
No. 1		1,235	1,420	1,540	1,300,000	
No. 1, open grain		980	1,125	1,225	1,100,000	
No. 2		1,170	1,345	1,465	1,200,000	
No. 2, open grain		915	1,055	1,145	1,000,000	
No. 3		665	765	830	1,100,000	
No. 3, open grain		540	620	670	900,000	
Clear Structural	2×12	2,015	2,315	2,515	1,400,000	RIS
Select Structural		1,555	1,785	1,940	1,400,000	
Select Structural, open grain		1,265	1,455	1,580	1,100,000	
No. 1		1,120	1,290	1,400	1,300,000	
No. 1, open grain		890	1,025	1,115	1,100,000	
No. 2		1,065	1,225	1,330	1,200,000	
No. 2, open grain		835	960	1,040	1,000,000	
No. 3		605	695	755	1,100,000	
No. 3, open grain		490	560	610	900,000	
<b>SOUTHERN PINE</b>						
Dense Select Structural	2×4	3,510	4,030	4,380	1,900,000	SPIB
Select Structural		3,280	3,770	4,100	1,800,000	
Non-Dense Select Structural		3,050	3,500	3,810	1,700,000	
No. 1 Dense		2,300	2,650	2,880	1,800,000	
No. 1		2,130	2,450	2,660	1,700,000	
No. 1 Non-Dense		1,950	2,250	2,440	1,600,000	
No. 2 Dense		1,960	2,250	2,440	1,700,000	
No. 2		1,720	1,980	2,160	1,600,000	
No. 2 Non-Dense		1,550	1,790	1,940	1,400,000	
No. 3		980	1,120	1,220	1,400,000	
Stud		1,010	1,160	1,260	1,400,000	
Construction		1,270	1,450	1,580	1,500,000	
Standard		720	825	900	1,300,000	
Utility		345	395	430	1,300,000	

**TABLE 23-I-X-1—VALUES FOR JOISTS AND RAFTERS—VISUALLY GRADED LUMBER—(Continued)**

SPECIES AND GRADE	SIZE (Inches) × 25.4 for mm	DESIGN VALUE IN BENDING "F <sub>b</sub> " psi			MODULUS OF ELASTICITY "E" psi	GRADING RULES AGENCY
		Normal Duration	Snow Loading	7-day Loading		
<b>SOUTHERN PINE—(continued)</b>						
Dense Select Structural	2×6	3,100	3,570	3,880	1,900,000	SPIB
Select Structural		2,930	3,370	3,670	1,800,000	
Non-Dense Select Structural		2,700	3,110	3,380	1,700,000	
No. 1 Dense		2,010	2,310	2,520	1,800,000	
No. 1		1,900	2,180	2,370	1,700,000	
No. 1 Non-Dense		1,720	1,980	2,160	1,600,000	
No. 2 Dense		1,670	1,920	2,080	1,700,000	
No. 2		1,440	1,650	1,800	1,600,000	
No. 2 Non-Dense		1,320	1,520	1,650	1,400,000	
No. 3		865	990	1,080	1,400,000	
Stud		890	1,020	1,110	1,400,000	
Dense Select Structural	2×8	2,820	3,240	3,520	1,900,000	SPIB
Select Structural		2,650	3,040	3,310	1,800,000	
Non-Dense Select Structural		2,420	2,780	3,020	1,700,000	
No. 1 Dense		1,900	2,180	2,370	1,800,000	
No. 1		1,730	1,980	2,160	1,700,000	
No. 1 Non-Dense		1,550	1,790	1,940	1,600,000	
No. 2 Dense		1,610	1,850	2,010	1,700,000	
No. 2		1,380	1,590	1,720	1,600,000	
No. 2 Non-Dense		1,260	1,450	1,580	1,400,000	
No. 3		805	925	1,010	1,400,000	
Dense Select Structural		2×10	2,470	2,840	3,090	
Select Structural	2,360		2,710	2,950	1,800,000	
Non-Dense Select Structural	2,130		2,450	2,660	1,700,000	
No. 1 Dense	1,670		1,920	2,080	1,800,000	
No. 1	1,500		1,720	1,870	1,700,000	
No. 1 Non-Dense	1,380		1,590	1,730	1,600,000	
No. 2 Dense	1,380		1,590	1,730	1,700,000	
No. 2	1,210		1,390	1,510	1,600,000	
No. 2 Non-Dense	1,090		1,260	1,370	1,400,000	
No. 3	690		795	865	1,400,000	

(Continued)

TABLE 23-I-X-1—VALUES FOR JOISTS AND RAFTERS—VISUALLY GRADED LUMBER—(Continued)

SPECIES AND GRADE	SIZE (inches) × 25.4 for mm	DESIGN VALUE IN BENDING "F <sub>b</sub> " psi			MODULUS OF ELASTICITY "E" psi	GRADING RULES AGENCY
		Normal Duration	Snow Loading	7-day Loading		
		× 0.00689 for N/mm <sup>2</sup>				
<b>SOUTHERN PINE—(continued)</b>						
Dense Select Structural	2×12	2,360	2,710	2,950	1,900,000	SPIB
Select Structural		2,190	2,510	2,730	1,800,000	
Non-Dense Select Structural		2,010	2,310	2,520	1,700,000	
No. 1 Dense		1,550	1,790	1,940	1,800,000	
No. 1		1,440	1,650	1,800	1,700,000	
No. 1 Non-Dense		1,320	1,520	1,650	1,600,000	
No. 2 Dense		1,320	1,520	1,650	1,700,000	
No. 2		1,120	1,290	1,400	1,600,000	
No. 2 Non-Dense		1,040	1,190	1,290	1,400,000	
No. 3		660	760	825	1,400,000	
<b>SPRUCE-PINE-FIR</b>						
Select Structural	2×4	2,155	2,480	2,695	1,500,000	NLGA
No. 1/No. 2		1,510	1,735	1,885	1,400,000	
No. 3		865	990	1,080	1,200,000	
Stud		855	980	1,065	1,200,000	
Construction Standard		1,120	1,290	1,400	1,300,000	
Standard		635	725	790	1,200,000	
Utility		290	330	360	1,100,000	
Select Structural	2×6	1,870	2,150	2,335	1,500,000	
No. 1/No. 2		1,310	1,505	1,635	1,400,000	
No. 3		750	860	935	1,200,000	
Stud		775	895	970	1,200,000	
Select Structural	2×8	1,725	1,985	2,155	1,500,000	
No. 1/No. 2		1,210	1,390	1,510	1,400,000	
No. 3		690	795	865	1,200,000	
Select Structural	2×10	1,580	1,820	1,975	1,500,000	
No. 1/No. 2		1,105	1,275	1,385	1,400,000	
No. 3		635	725	790	1,200,000	
Select Structural	2×12	1,440	1,655	1,795	1,500,000	
No. 1/No. 2		1,005	1,155	1,260	1,400,000	
No. 3		575	660	720	1,200,000	
<b>SPRUCE-PINE-FIR (South)</b>						
Select Structural	2×4	2,245	2,580	2,805	1,300,000	NELMA NSLB WCLIB WWPA
No. 1		1,465	1,685	1,835	1,200,000	
No. 2		1,295	1,490	1,615	1,100,000	
No. 3		735	845	915	1,000,000	
Stud		725	835	910	1,000,000	
Construction Standard		980	1,125	1,220	1,000,000	
Standard		545	630	685	900,000	
Utility		260	300	325	900,000	

**TABLE 23-I-X-1—VALUES FOR JOISTS AND RAFTERS—VISUALLY GRADED LUMBER—(Continued)**

SPECIES AND GRADE	SIZE (Inches) × 25.4 for mm	DESIGN VALUE IN BENDING "F <sub>b</sub> " psi			MODULUS OF ELASTICITY "E" psi	GRADING RULES AGENCY
		Normal Duration	Snow Loading	7-day Loading		
<b>SPRUCE-PINE-FIR (South)—(continued)</b>						
Select Structural	2×6	1,945	2,235	2,430	1,300,000	NELMA NSLB WCLIB WWPA
No. 1		1,270	1,460	1,590	1,200,000	
No. 2		1,120	1,290	1,400	1,100,000	
No. 3		635	730	795	1,000,000	
Stud		660	760	825	1,000,000	
Select Structural	2×8	1,795	2,065	2,245	1,300,000	
No. 1		1,175	1,350	1,465	1,200,000	
No. 2		1,035	1,190	1,295	1,100,000	
No. 3	585	675	735	1,000,000		
Select Structural	2×10	1,645	1,890	2,055	1,300,000	
No. 1		1,075	1,235	1,345	1,200,000	
No. 2		950	1,090	1,185	1,100,000	
No. 3		540	620	670	1,000,000	
Select Structural	2×12	1,495	1,720	1,870	1,300,000	
No. 1		980	1,125	1,220	1,200,000	
No. 2		865	990	1,080	1,100,000	
No. 3		490	560	610	1,000,000	
<b>WESTERN CEDARS</b>						
Select Structural	2×4	1,725	1,985	2,155	1,100,000	WCLIB WWPA
No. 1		1,250	1,440	1,565	1,000,000	
No. 2		1,210	1,390	1,510	1,000,000	
No. 3		690	795	865	900,000	
Stud		695	800	870	900,000	
Construction		920	1,060	1,150	900,000	
Standard		520	595	645	800,000	
Utility		260	300	325	800,000	
Select Structural	2×6	1,495	1,720	1,870	1,100,000	
No. 1		1,085	1,245	1,355	1,000,000	
No. 2		1,045	1,205	1,310	1,000,000	
No. 3		600	690	750	900,000	
Stud	635	725	790	900,000		
Select Structural	2×8	1,380	1,585	1,725	1,100,000	
No. 1		1,000	1,150	1,250	1,000,000	
No. 2		965	1,110	1,210	1,000,000	
No. 3	550	635	690	900,000		
Select Structural	2×10	1,265	1,455	1,580	1,100,000	
No. 1		915	1,055	1,145	1,000,000	
No. 2		885	1,020	1,105	1,000,000	
No. 3		505	580	635	900,000	

(Continued)

**TABLE 23-I-X-1—VALUES FOR JOISTS AND RAFTERS—VISUALLY GRADED LUMBER—(Continued)**

SPECIES AND GRADE	SIZE (Inches) × 25.4 for mm	DESIGN VALUE IN BENDING "F <sub>b</sub> " psi			MODULUS OF ELASTICITY "E" psi	GRADING RULES AGENCY
		Normal Duration	Snow Loading	7-day Loading		
		× 0.00689 for N/mm <sup>2</sup>				
<b>WESTERN CEDARS—(continued)</b>						
Select Structural	2×12	1,150	1,325	1,440	1,100,000	WCLIB WWPA
No. 1		835	960	1,040	1,000,000	
No. 2		805	925	1,005	1,000,000	
No. 3		460	530	575	900,000	
<b>WESTERN WOODS</b>						
Select Structural	2×4	1,510	1,735	1,885	1,200,000	WCLIB WWPA
No. 1		1,120	1,290	1,400	1,100,000	
No. 2		1,120	1,290	1,400	1,000,000	
No. 3		645	745	810	900,000	
Stud		635	725	790	900,000	
Construction		835	960	1,040	1,000,000	
Standard		460	530	575	900,000	
Utility		230	265	290	800,000	
Select Structural	2×6	1,310	1,505	1,635	1,200,000	WCLIB WWPA
No. 1		970	1,120	1,215	1,100,000	
No. 2		970	1,120	1,215	1,000,000	
No. 3		560	645	700	900,000	
Stud	575	660	720	900,000		
Select Structural	2×8	1,210	1,390	1,510	1,200,000	WCLIB WWPA
No. 1		895	1,030	1,120	1,100,000	
No. 2		895	1,030	1,120	1,000,000	
No. 3		520	595	645	900,000	
Select Structural	2×10	1,105	1,275	1,385	1,200,000	WCLIB WWPA
No. 1		820	945	1,030	1,100,000	
No. 2		820	945	1,030	1,000,000	
No. 3		475	545	595	900,000	
Select Structural	2×12	1,005	1,155	1,260	1,200,000	WCLIB WWPA
No. 1		750	860	935	1,100,000	
No. 2		750	860	935	1,000,000	
No. 3		430	495	540	900,000	
<b>WHITE OAK</b>						
Select Structural	2×4	2,070	2,380	2,590	1,100,000	NELMA
No. 1		1,510	1,735	1,885	1,000,000	
No. 2		1,465	1,685	1,835	900,000	
No. 3		820	940	1,025	800,000	
Stud		820	945	1,030	800,000	
Construction		1,095	1,255	1,365	900,000	
Standard		605	695	755	800,000	
Utility		290	330	360	800,000	

**TABLE 23-I-X-1—VALUES FOR JOISTS AND RAFTERS—VISUALLY GRADED  
LUMBER—(Continued)**

SPECIES AND GRADE	SIZE (inches) × 25.4 for mm	DESIGN VALUE IN BENDING "F <sub>b</sub> " psi			MODULUS OF ELASTICITY "E" psi × 0.00689 for N/mm <sup>2</sup>	GRADING RULES AGENCY
		Normal Duration	Snow Loading	7-day Loading		
<b>WHITE OAK—(continued)</b>						
Select Structural	2×6	1,795	2,065	2,245	1,100,000	NELMA
No. 1		1,310	1,505	1,635	1,000,000	
No. 2		1,270	1,460	1,590	900,000	
No. 3		710	815	890	800,000	
Stud		750	860	935	800,000	
Select Structural	2×8	1,655	1,905	2,070	1,100,000	
No. 1		1,210	1,390	1,510	1,000,000	
No. 2		1,175	1,350	1,465	900,000	
No. 3	655	755	820	800,000		
Select Structural	2×10	1,520	1,745	1,900	1,100,000	
No. 1		1,105	1,275	1,385	1,000,000	
No. 2		1,075	1,235	1,345	900,000	
No. 3		600	690	750	800,000	
Select Structural	2×12	1,380	1,585	1,725	1,100,000	
No. 1		1,005	1,155	1,260	1,000,000	
No. 2		980	1,125	1,220	900,000	
No. 3		545	630	685	800,000	
<b>YELLOW POPLAR</b>						
Select Structural	2×4	1,725	1,985	2,155	1,500,000	NSLB
No. 1		1,250	1,440	1,565	1,400,000	
No. 2		1,210	1,390	1,510	1,300,000	
No. 3		690	795	865	1,200,000	
Stud		695	800	870	1,200,000	
Construction Standard		920	1,060	1,150	1,300,000	
Utility		520	595	645	1,100,000	
Utility	230	265	290	1,100,000		
Select Structural	2×6	1,495	1,720	1,870	1,500,000	
No. 1		1,085	1,245	1,355	1,400,000	
No. 2		1,045	1,205	1,310	1,300,000	
No. 3		600	690	750	1,200,000	
Stud	635	725	790	1,200,000		
Select Structural	2×8	1,380	1,585	1,725	1,500,000	
No. 1		1,000	1,150	1,250	1,400,000	
No. 2		965	1,110	1,210	1,300,000	
No. 3	550	635	690	1,200,000		
Select Structural	2×10	1,265	1,455	1,580	1,500,000	
No. 1		915	1,055	1,145	1,400,000	
No. 2		885	1,020	1,105	1,300,000	
No. 3	505	580	635	1,200,000		
Select Structural	2×12	1,150	1,325	1,440	1,500,000	
No. 1		835	960	1,040	1,400,000	
No. 2		805	925	1,005	1,300,000	
No. 3	460	530	575	1,200,000		

**TABLE 23-I-X-2—VALUES FOR JOISTS AND RAFTERS—MECHANICALLY GRADED LUMBER**  
For use in Tables 23-V-J-1 through 23-V-R-12 and Division V only.

GRADE DESIGNATION	SIZE (Inches) × 25.4 for mm	DESIGN VALUE IN BENDING "F <sub>b</sub> " psi			MODULUS OF ELASTICITY "E" psi	GRADING RULES AGENCIES	
		Normal Duration	Snow Loading	7-day Loading			
		× 0.00689 for N/mm <sup>2</sup>					
<b>MACHINE STRESS RATED (MSR) LUMBER</b>							
900f-1.0E	2×4 and wider	1,040	1,190	1,290	1,000,000	WCLIB,WWPA	
1200f-1.2E		1,380	1,590	1,730	1,200,000	NLGA,SPIB,WCLIB,WWPA	
1350f-1.3E		1,550	1,790	1,940	1,300,000	SPIB,WCLIB,WWPA	
1450f-1.3E		1,670	1,920	2,080	1,300,000	NLGA,WCLIB,WWPA	
1500f-1.3E		1,730	1,980	2,160	1,300,000	SPIB	
1500f-1.4E		1,730	1,980	2,160	1,400,000	NLGA,SPIB,WCLIB,WWPA	
1650f-1.4E		1,900	2,180	2,370	1,400,000	SPIB	
1650f-1.5E		1,900	2,180	2,370	1,500,000	NLGA,SPIB,WCLIB,WWPA	
1800f-1.6E		2,070	2,380	2,590	1,600,000	NLGA,SPIB,WCLIB,WWPA	
1950f-1.5E		2,240	2,580	2,800	1,500,000	SPIB	
1950f-1.7E		2,240	2,580	2,800	1,700,000	NLGA,SPIB,WWPA	
2100f-1.8E		2,420	2,780	3,020	1,800,000	NLGA,SPIB,WCLIB,WWPA	
2250f-1.6E		2,590	2,980	3,230	1,600,000	SPIB	
2250f-1.9E		2,590	2,980	3,230	1,900,000	NLGA,SPIB,WWPA	
2400f-1.7E		2,760	3,170	3,450	1,700,000	SPIB	
2400f-2.0E		2,760	3,170	3,450	2,000,000	NLGA,SPIB,WCLIB,WWPA	
2550f-2.1E		2,930	3,370	3,670	2,100,000	NLGA,SPIB,WWPA	
2700f-2.2E		3,110	3,570	3,880	2,200,000	NLGA,SPIB,WCLIB,WWPA	
2850f-2.3E		3,280	3,770	4,100	2,300,000	SPIB,WWPA	
3000f-2.4E		3,450	3,970	4,310	2,400,000	NLGA,SPIB	
3150f-2.5E		3,620	4,170	4,530	2,500,000	SPIB	
3300f-2.6E		3,800	4,360	4,740	2,600,000	SPIB	
900f-1.2E		2×6 and wider	1,040	1,190	1,290	1,200,000	NLGA,WCLIB
1200f-1.5E			1,380	1,590	1,730	1,500,000	NLGA,WCLIB
1350f-1.8E			1,550	1,790	1,940	1,800,000	NLGA
1500f-1.8E	1,730		1,980	2,160	1,800,000	WCLIB	
1800f-2.1E	2,070		2,380	2,590	2,100,000	NLGA,WCLIB	
<b>MACHINE EVALUATED LUMBER (MEL)</b>							
M-10	2×4 and wider	1,610	1,850	2,010	1,200,000	SPIB	
M-11		1,780	2,050	2,230	1,500,000		
M-12		1,840	2,120	2,300	1,600,000		
M-13		1,840	2,120	2,300	1,400,000		
M-14		2,070	2,380	2,590	1,700,000		
M-15		2,070	2,380	2,590	1,500,000		
M-16		2,070	2,380	2,590	1,500,000		
M-17		2,240	2,580	2,800	1,700,000		
M-18		2,300	2,650	2,880	1,800,000		
M-19		2,300	2,650	2,880	1,600,000		
M-20		2,300	2,650	2,880	1,900,000		
M-21		2,650	3,040	3,310	1,900,000		
M-22		2,700	3,110	3,380	1,700,000		
M-23		2,760	3,170	3,450	1,800,000		
M-24		3,110	3,570	3,880	1,900,000		
M-25	3,160	3,640	3,950	2,200,000			

**TABLE 23-I-X-2—VALUES FOR JOISTS AND RAFTERS—MECHANICALLY  
GRADED LUMBER—(Continued)**

GRADE DESIGNATION	SIZE (Inches)  × 25.4 for mm	DESIGN VALUE IN BENDING "F <sub>b</sub> " psi			MODULUS OF ELASTICITY "E" psi	GRADING RULES AGENCIES
		Normal Duration	Snow Loading	7-day Loading		
MACHINE EVALUATED LUMBER (MEL)—(continued)						
M-26	2×4	3,220	3,700	4,030	2,000,000	SPIB
M-27	and wider	3,450	3,970	4,310	2,100,000	

The note to Table 23-I-X-1 applies also to mechanically graded lumber.

**Division II—DESIGN STANDARD FOR SPACED WOOD COLUMN DESIGN**  
**Based on National Design Specification for Wood Construction (1982), including**  
**the 1982 Supplement, American Forest and Paper Association**

**SECTION 2327 — SCOPE**

This division shall cover requirements for spaced column design, in accordance with Division I.

**SECTION 2328 — SPACED WOOD COLUMNS**

Wood columns shall be designed in accordance with the following formulas and requirements:

- $A$  = area of column cross section, square inches ( $\text{mm}^2$ ).
- $F_c$  = allowable unit stress in compression parallel to grain as given in Tables 23-I-A-1 and 23-I-A-2 of Division I.
- $F'_c$  = allowable unit stress in compression parallel to grain adjusted to  $l/d$  ratio.
- $d$  = dimension of least side of individual members of spaced columns, inches (mm).
- $d_2$  = dimension of wide face of individual member, inches (mm).
- $E$  = modulus of elasticity.
- $l_1$  and  $l_2$  = distances from center to center of lateral supports of continuous spaced columns, and from end to end of simple spaced columns, inches (mm).
- $l_3$  = distance in spaced column from center of connector in end blocks to center of spacer block, inches (mm).
- $P$  = total load, pounds (N).
- $P/A$  = maximum load per unit of cross-sectional area.

**SECTION 2329 — COLUMNS, CONNECTOR JOINED**

Spaced columns are formed of two or more individual members with their longitudinal axis parallel, separated at the ends and middle points of their length by blocking and joined at the ends by timber connectors capable of developing the required shear resistance.

Spaced columns shall be classified as to end fixity, either as condition "a" or condition "b," as follows:

**Condition a.** The centroid of connectors or a connector group in the end block shall be within  $1/20$  of the length  $l_1$  from the column end.

**Condition b.** The centroid of connectors or a connector group in the end block shall be between  $1/20$  and  $1/10$  of the length  $l_1$  from the column end.

**SECTION 2330 — LIMITATIONS**

For individual members of a spaced column:

1.  $l_1/d_1$  shall not exceed 80, where  $l_1$  is the distance between lateral supports that provide restraint perpendicular to the wide faces of the individual members.
2.  $l_2/d_2$  shall not exceed 50, where  $l_2$  is the distance between lateral supports that provide restraint in a direction parallel to the wide faces of the individual members.
3.  $l_3/d_1$  shall not exceed 40, where  $l_3$  is the distance between the centroid of connectors in an end block and the center of the spacer block.

**TABLE 23-II-A—END-SPACER BLOCK CONSTANTS FOR CONNECTOR-JOINED SPACED COLUMNS**

SPECIES GROUP	
A	$K_S = 9.55 (l_1/d_1 - 11) \leq 468$
B	$K_S = 8.14 (l_1/d_1 - 11) \leq 339$
C	$K_S = 6.73 (l_1/d_1 - 11) \leq 330$
D	$K_S = 5.32 (l_1/d_1 - 11) \leq 261$

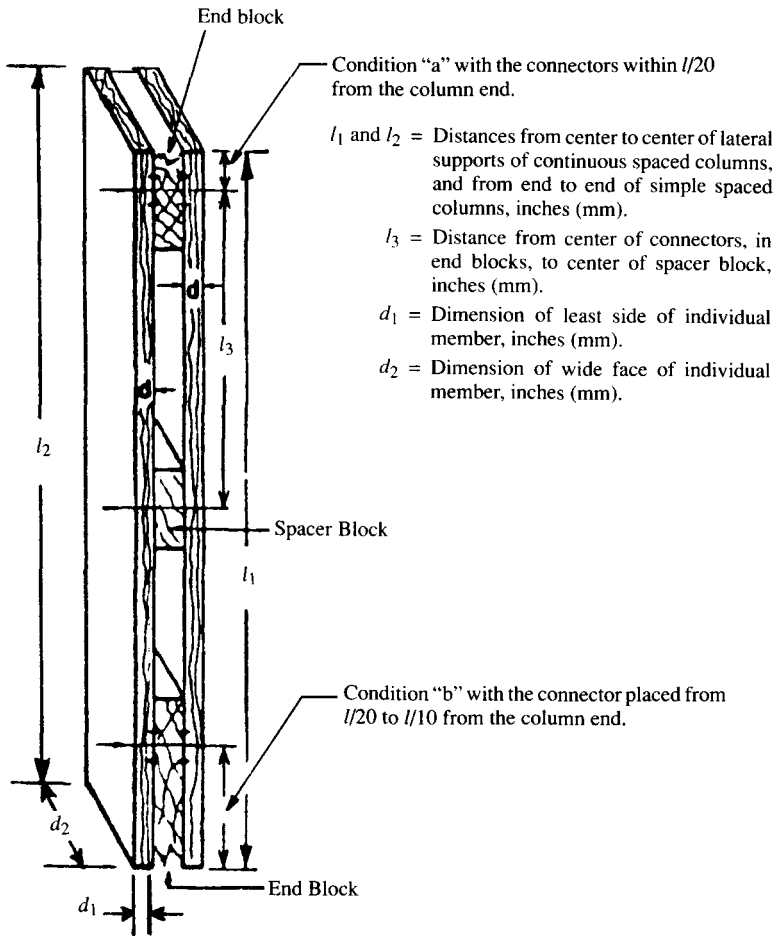

**FIGURE 23-II-1—SPACED COLUMN, CONNECTOR JOINED**

### SECTION 2331 — LOCATION OF SPACER AND END BLOCKS

A single spacer block shall be located within the middle one tenth of the column length,  $l$ , and, if so located, connectors are not required for this block. If there are two or more spacer blocks, the distance between any two blocks shall not exceed one half the distance between centers of connectors in the end blocks. The requirements for connectors in spacer blocks when two or more blocks are used are the same as for end blocks.

End blocks shall be so placed that sufficient end and edge distances and spacings for the required minimum size and number of connectors are maintained in both end blocks and individual members, and connectors so placed that they comply with conditions "a" or "b" (Figure 23-II-1), depending on fixity factor assumed.

For spaced columns used as members of a truss, e.g., compression chords, a panel point which is stayed laterally, shall be considered as the end of the spaced column and the portion of the web members between the individual pieces making up a spaced column may be considered as the end blocks. For spaced column web members, joints at the tension chord may be considered stayed laterally by the tautness of the tension chord and by customary lateral braces between trusses.

If there are two or more connectors in a contact face, the position of the center of gravity of the group of connectors shall be used in measuring the distance from connectors in the end block to the end of the column for determining fixity condition "a" or "b" (Figure 23-II-2).

### SECTION 2332 — DIMENSIONS OF SPACER AND END BLOCKS

The thickness of spacer and end blocks shall not be less than that of the individual members of the spaced column nor shall the thickness, width and length of spacer and end blocks be less than that required for installation of connectors of a size and number capable of carrying a load equal to that computed from Table 23-II-A.

### SECTION 2333 — LOAD CAPACITY OF CONNECTORS IN END-SPACER BLOCKS

To obtain spaced-column action, the connectors in each pair of mutually contacting surfaces of end blocks and individual members at each end of a spaced column shall be of a size and number to provide a connector load capacity in pounds (N) equal to the cross-sectional area in square inches ( $\text{mm}^2$ ) of one of the individual members times the appropriate end-spacer block constant in Table 23-II-A.

If connector-joined spaced columns are used in locations other than dry, the connector loads should be adjusted for such conditions.

If spaced columns are a part of a truss system or other similar framing, the connectors required by joint design may be sufficient for end-block connectors but should be checked against Table 23-II-A.

### SECTION 2334 — ALLOWABLE LOADS FOR SPACED COLUMNS

The total allowable load for a spaced column is the sum of the allowable loads for each of its individual members determined as follows, except that the unit load for the individual members shall not exceed the allowable unit stresses in compression parallel to grain appropriately modified as provided in Division I nor shall such load exceed that permitted for net section for connectors.

Maximum design values  $F'_c$  in psi ( $\text{N}/\text{mm}^2$ ) of cross-sectional area of individual members of spaced columns shall be determined in accordance with the following formula:

$$F'_c = F^*_{c'} \left[ \frac{1 + (F_{cE}/F^*_{c'})}{2c'} - \sqrt{\left[ \frac{1 + (F_{cE}/F^*_{c'})}{2c'} \right]^2 - \frac{F_{cE}/F^*_{c'}}{c'}} \right]$$

**WHERE:**

$F_c^*$  = tabulated compressive design value multiplied by all of the applicable adjustment factors.

$$F_{cE} = \frac{K_{cE} K_x E'}{(l_e/d)^2}$$

**WHERE:**

$c'$  = 0.8 for sawn lumber.

$c'$  = 0.85 for round timber piles.

$c'$  = 0.90 for glued-laminated timber.

$K_{cE}$  = 0.3 for visually graded lumber.

$K_{cE}$  = 0.418 for products such as machine stress-rated sawn lumber and glued-laminated timber.

$K_x$  = 2.5 for fixity condition a.

$K_x$  = 3.0 for fixity condition b.

$l_e$  =  $l_1, l_2, \dots$

When individual members of a spaced column are of different species, grades or thicknesses, the lesser allowable compression parallel to grain design value,  $F'_c$ , for the weaker member shall apply to both members.

The allowable compression parallel to grain design value,  $F'_c$ , for a spaced column shall not exceed the allowable compression parallel to grain design value,  $F'_c$ , for the individual members evaluated as solid columns without regard to fixity in accordance with Section 2307 using the column slenderness ratio  $l_2/d_2$  (see Figure 23-II-1).

For especially severe service conditions and/or extraordinary hazard, use of lower allowable design values may be necessary.

The equations in Section 2308 for combined flexure and axial loading apply to spaced columns only for uniaxial bending in a direction parallel to the wide face of the individual member (dimension  $d_2$  in Figure 23-II-1).

Where the design values  $F'_c$  for the two individual members of a spaced column are different because the members are of different species, grades or thicknesses, the lesser value of  $F'_c$  shall apply to both members.

The design values shall not exceed the design values for the individual members taken as simple solid columns without regard to fixity, when determined with Section 2307 by using dimensions  $d_2$  and length  $l_2$  where  $l_2$  is the distance between the lateral supports which provide restraint in a direction parallel to dimension  $d_2$ .

**Division III—DESIGN STANDARD FOR TIMBER CONNECTOR JOINTS, BOLTED JOINTS, DRIFT BOLTS AND WOOD SCREWS, AND LAG SCREWS; METAL PLATE CONNECTED WOOD TRUSS DESIGN, AND NAILS AND STAPLES**

**Based on the National Design Specification for Wood Construction (1991), including the 1991 Supplement, of the American Forest and Paper Association; Design Specifications for Metal Plate Connected Wood Truss, TPI-85; Design Specification for Metal Plate Connected Parallel Chord Wood Trusses, PCT-80 of the Truss Plate Institute; and Federal Specification No. FF-N-105B, dated March 17, 1971**

**SECTION 2335 — MECHANICAL CONNECTIONS**

**2335.1 Scope.** This part applies to the engineering design of connections using bolts, lag screws, split ring or shear plate connectors, drift bolts, drift pins, wood screws, nails, spikes, metal plate connectors or spike grids in sawn lumber, glued-laminated timber and timber piles. Methods of analysis and test data for establishing design values for connections made with more than one type of fastener are not included. Design values for mixed fastener connections shall be based on tests or other analysis.

Except where specifically limited elsewhere herein, the provisions of Section 2335 shall apply to all fastener types covered in Sections 2336 through 2342.

Connection design provisions in Sections 2335 through 2342 shall not preclude the use of connections where it can be demonstrated by analysis based on generally recognized theory, full-scale or prototype loading test, studies of model analogues or extensive experience in use that the connections can perform satisfactorily in their intended end uses.

**2335.2 Stresses in Members at Connections.** Structural members shall be checked for load-carrying capacity at connections in accordance with good engineering practice.

**2335.3 Eccentric Connections.** Eccentric split ring connector, shear plate connector, bolt or lag screw connections that induce tension stress perpendicular to grain in the wood shall not be used unless appropriate engineering procedures or tests are employed in the design of such connections to ensure that all applied loads will be safely carried. Connections similar to those in Figure 23-III-1 are examples of connections requiring appropriate engineering procedures or tests.

**2335.4 Design Values.**

**2335.4.1 Single fastener connections.** Parts I through VIII contain provisions for calculating nominal design values for various types of single fastener connections. Design values for connections in a given species apply to all grades of that species unless otherwise indicated. Nominal design values for bolts, lag screws, wood screws, nails and spikes are based on yield limit formulas which model the various failure modes that may occur in a connection (see Figure 23-III-22).

**2335.4.2 Multiple fastener connections.** When a connection contains two or more fasteners of the same type or similar size, each of which exhibits the same yield mode, the total allowable design value for the connection shall be the sum of the allowable design values for each individual fastener.

**2335.4.3 Design of metal parts.** Metal plates, hangers, fasteners and other metal parts shall be designed in accordance with accepted metal practices to resist failure in tension, shear, bearing (metal on metal), bending and buckling shear. When the capacity of a connection is controlled by metal strength, rather than wood strength, allowable metal strength shall not be multiplied by the modification factors in this standard. In addition, metal strength shall not be increased by wind and earthquake factors if design loads have already been reduced by load combination factors.

**2335.5 Adjustment of Design Values.**

**2335.5.1 Applicability of modification factors.** Nominal design values ( $Z$ ,  $W$ ) shall be multiplied by all applicable modification factors to determine allowable design values ( $Z'$ ,  $W'$ ). Table

23-III-A specifies the modification factors which apply to nominal lateral design values ( $Z$ ) and nominal withdrawal design values ( $W$ ) for each fastener type. The actual load applied to a connection shall not exceed the allowable design value ( $Z'$ ,  $W'$ ) for the connection.

**2335.5.2 Load duration factor,  $C_D$ .** Nominal design values shall be multiplied by the load duration factors,  $C_D \leq 1.33$ , except when the capacity of the connection is controlled by metal strength (see Sections 2304.3.4 and 2335.4.3). The impact load duration factor shall not apply to connections.

**2335.5.3 Wet service factor,  $C_M$ .** Nominal design values are for connections in wood seasoned to a moisture content of 19 percent or less and used under continuously dry conditions, as in most covered structures. For connections in wood that is unseasoned or partially seasoned, or when connections are exposed to wet-service conditions in use, nominal design values shall be multiplied by the moisture content factors,  $C_M$ , specified in Table 23-III-B.

**2335.5.4 Temperature factor,  $C_t$ .** Nominal design values shall be multiplied by the following temperature factors,  $C_t$ , for connections that will experience sustained exposure to elevated temperatures up to 150°F. (65.6°C.).

TEMPERATURE FACTORS,  $C_t$ , FOR CONNECTIONS

IN-SERVICE MOISTURE CONDITIONS <sup>1</sup>	T ≤ 100°F. (37.8°C.)	100°F. (37.8°C.) ≤ T ≤ 125°F. (51.7°C.)	125°F. (51.7°C.) < T ≤ 150°F. (65.6°C.)
Dry	1.0	0.8	0.7
Wet	1.0	0.7	0.5

<sup>1</sup>Wet and dry service conditions for connections are specified in Section 2335.5.3.

**2335.5.5 Fire-retardant treatment.** Allowable design values for connections in lumber and structural glued-laminated timber pressure impregnated with fire-retardant chemicals shall be obtained from the company providing the treatment and redrying service. The impact load duration factor shall not apply to connections in wood pressure impregnated with fire-retardant chemicals.

**2335.5.6 Group action factor,  $C_g$ .** Nominal lateral design values for split ring connectors, shear plate connectors, bolts with  $D \leq 1$  inch (25.4 mm), or lag screws in a row shall be multiplied by the following group action factor,  $C_g$ :

$$C_g = \left\{ \frac{m(1 - m^{2n})}{n[(1 + R_{EA}m^n)(1 + m) - 1 + m^{2n}]} \right\} \left\{ \frac{1 + R_{EA}}{1 - m} \right\}$$

**WHERE:**

$A_m$  = gross cross-sectional area of main member, square inch (mm<sup>2</sup>).

$A_s$  = sum of gross cross-sectional areas of side members, square inch (mm<sup>2</sup>).

$D$  = diameter of bolt or lag screw, inches (mm).

$E_m$  = modulus of elasticity of main member, pounds per square inch (psi) (N/mm<sup>2</sup>).

$E_s$  = modulus of elasticity of side members, psi (N/mm<sup>2</sup>).

$$m = u - \sqrt{u^2 - 1}$$

$n$  = number of fasteners in a row.

$R_{EA}$  = the lesser of  $\frac{E_s A_s}{E_m A_m}$  or  $\frac{E_m A_m}{E_s A_s}$

$s$  = center-to-center spacing between adjacent fasteners in a row, inches (mm).

$$u = 1 + \gamma \frac{s}{2} \left( \frac{1}{E_m A_m} + \frac{1}{E_s A_s} \right)$$

$\gamma$  = load/slip modulus for a connection, pounds per inch (N/mm).

$\gamma$  = 500,000 pounds per inch (87 500 N/mm) for 4-inch (102 mm) split ring or shear plate connectors.

$\gamma = 400,000$  pounds per inch (70 000 N/mm) for 2 $\frac{1}{2}$ -inch (64 mm) split ring or 2 $\frac{5}{8}$ -inch (67 mm) shear plate connectors.

$\gamma = (180,000)(D^{1.5})$  [For **SI**:  $\gamma = (246)(D^{1.5})$ ] for bolts or lag screws in wood-to-wood connections.

$\gamma = (270,000)(D^{1.5})$  [For **SI**:  $\gamma = (369)(D^{1.5})$ ] for bolts or lag screws in wood-to-metal connections.

Group action factors for various connection geometries are provided in Tables 23-III-C, 23-III-D, 23-III-E and 23-III-F.

For determining group action factors, a row of fasteners is defined as any of the following:

1. Two or more split ring or shear plate connector units, as defined in Section 2338.1.1, aligned with the direction of load.
2. Two or more bolts of the same diameter loaded in single or multiple shear and aligned with the direction of load.
3. Two or more lag screws of the same type and size loaded in single shear and aligned with the direction of load.

When fasteners in adjacent rows are staggered and the distance between adjacent rows is less than one fourth the distance between the closest fasteners in adjacent rows measured parallel to the rows, the adjacent rows shall be considered as one row for purposes of determining group action factors. For groups of fasteners having an even number of rows, this principle shall apply to each pair of rows. For groups of fasteners having an odd number of rows, the most conservative interpretation shall apply (see Figure 23-III-2).

Gross section areas shall be used, with no reductions for net section, when calculating  $A_m$  and  $A_s$  for determining group action factors. When a member is loaded perpendicular to grain, its equivalent cross-sectional area shall be the product of the thickness of the member and the overall width of the fastener group. When only one row of fasteners is used, the width of the fastener group shall be the minimum parallel-to-grain spacing of the fasteners.

## SECTION 2336 — BOLTS

### 2336.1 General.

**2336.1.1 Scope.** This part covers detailed design considerations and limitations of bolted joints. Tabulated allowable bolt loads are the maximum for normal loading. Pertinent adjustments of stresses and provisions for lumber in Division I, except as otherwise provided in this division, apply likewise to the tabulated bolt loads given in this division.

**2336.1.2 Fabrication and assembly.** Bolt holes shall be a minimum of  $\frac{1}{32}$  inch (0.8 mm) to a maximum of  $\frac{1}{16}$  inch (1.6 mm) larger than the bolt diameter.

Careful centering of holes in main members and splice plates is assumed. Tight fit requiring forcible driving of bolts is not allowed.

A metal plate, metal strap, or washer not less than a standard cut washer shall be between the wood and the bolt head and between the wood and the nut.

Bolt design values apply to connections with tight nuts and connections with loose nuts resulting from shrinkage of the wood members.

The threaded portion of bolts subject to wood bearing shall be kept to a practical minimum.

### 2336.2 Design Values for Single Shear Connections.

**2336.2.1 Wood-to-wood connections.** For single shear (two member) wood-to-wood connections (see Figures 23-III-3 and 23-III-22) where:

1. The load acts perpendicular to the axis of the bolt.
2. Edge distances, end distances and spacing are sufficient to develop full design values (see Section 2336.5).

The nominal bolt design values,  $Z$ , shall be the lesser of:

$$Z = \frac{D t_m F_{em}}{4K_{\theta}} \quad \text{MODE I}_m \text{ (36-1)}$$

$$Z = \frac{D t_s F_{es}}{4K_{\theta}} \quad \text{MODE I}_s \text{ (36-2)}$$

$$Z = \frac{k_1 D t_s F_{es}}{3.6K_{\theta}} \quad \text{MODE II (36-3)}$$

$$Z = \frac{k_2 D t_m F_{em}}{3.2(1 + 2R_e)K_{\theta}} \quad \text{MODE III}_m \text{ (36-4)}$$

$$Z = \frac{k_3 D t_s F_{em}}{3.2(2 + R_e)K_{\theta}} \quad \text{MODE III}_s \text{ (36-5)}$$

$$Z = \frac{D^2}{3.2K_{\theta}} \sqrt{\frac{2 F_{em} F_{yb}}{3(1 + R_e)}} \quad \text{MODE IV (36-6)}$$

WHERE:

$$k_1 = \frac{\sqrt{R_e + 2R_e^2(1 + R_t + R_t^2) + R_t^2 R_e^3 - R_e(1 + R_t)}}{(1 + R_e)}$$

$$k_2 = -1 + \sqrt{2(1 + R_e) + \frac{2F_{yb}(1 + 2R_e)D^2}{3F_{em} t_m^2}}$$

$$k_3 = -1 + \sqrt{\frac{2(1 + R_e)}{R_e} + \frac{2F_{yb}(2 + R_e)D^2}{3F_{em} t_s^2}}$$

- $D$  = nominal bolt diameter, inches (mm).  
 $F_{em}$  = dowel bearing strength of main (thicker) member, pounds per square inch (N/mm<sup>2</sup>) (see Table 23-III-G).  
 $F_{es}$  = dowel bearing strength of side (thinner) member, pounds per square inch (N/mm<sup>2</sup>) (see Table 23-III-G).  
 $F_{yb}$  = bending yield strength of bolt, pounds per square inch (N/mm<sup>2</sup>).  
 $K_{\theta}$  =  $1 + \Theta \max/360^\circ$ .  
 $R_e$  =  $F_{em}/F_{es}$   
 $R_t$  =  $t_m/t_s$   
 $t_m$  = thickness of main (thicker) member, inches (mm).  
 $t_s$  = thickness of side (thinner) member, inches (mm).  
 $\Theta$  = maximum angle of load to grain ( $0^\circ \leq \Theta \leq 90^\circ$ ) for any member in a connection.

When a main member is loaded at an angle to grain, the dowel bearing strength,  $F_{e\theta}$ , for the member shall be determined as follows:

$$F_{e\theta} = \frac{F_{e\parallel} F_{e\perp}}{F_{e\parallel} \sin^2 \Theta + F_{e\perp} \cos^2 \Theta} \quad (36-7)$$

**WHERE:**

$\Theta$  = angle between direction of load and direction of grain (longitudinal axis of members).

Tables 23-III-J and 23-III-L provide nominal design values for various single shear bolted connections with wood side members. Nominal bolt design values,  $Z$ , shall be multiplied by all applicable modification factors (see Table 23-III-A) to obtain allowable bolt design values,  $Z'$ . Design values for one species of wood shall be permitted to be used for other species having the same or higher dowel bearing strength,  $F_e$  (see Table 23-III-G).

**2336.2.2 Wood-to-metal connections.** Nominal bolt design values,  $Z$ , for single shear (two-member) connections with metal side plates shall be the lesser of Formulas (36-1), (36-3), (36-4), (36-5) and (36-6), with  $F_{es}$  = bearing strength of the metal. Tables 23-III-K and 23-III-M provide nominal design values for various single shear bolted connections with steel side plates. Nominal bolt design values,  $Z$ , shall be multiplied by all applicable adjustment factors (see Table 23-III-A) to obtain allowable bolt design values,  $Z'$ . Design values for one species of wood shall be permitted to be used for other species having the same or higher dowel bearing strength,  $F_e$  (see Table 23-III-G).

Metal parts shall be designed in accordance with accepted metal practices (see Section 2335.4.3).

**2336.2.3 Wood-to-concrete connections.** When a connection consists of one wood member attached to concrete or masonry (single shear) by bolts embedded in concrete or masonry, the allowable bolt design value,  $Z'$ , for a single shear wood-to-wood connection shall apply with:

$t_m = 2t_s$  = twice the thickness of wood member.

$F_{em} = F_{es}$  = dowel bearing strength of wood member.

The concrete or masonry shall be of ample strength to support the applied load.

**2336.2.4 Load at angle to bolt axis.** When the applied load in a single shear (two member) connection is at an angle with the bolt axis, the bolt lengths in the two members shall be designated  $l_1$  and  $l_2$  (see Figure 23-III-4). The component of the load acting at 90 degrees with the bolt axis shall not exceed the allowable design value,  $Z'$ , for a connection in which two members at 90 degrees with the bolt axis have thicknesses  $t_s = l_s$  and  $t_m = l_m$ . Ample bearing area under washers or plates shall be provided to resist the load component acting parallel to the bolt axis.

**2336.3 Design Values for Double Shear Connections.**

**2336.3.1 Wood-to-wood connections.** For double shear (three-member) wood-to-wood connections (see Figures 23-III-5 and 23-III-22) where:

1. The load acts perpendicular to the axis of the bolt.
2. Side members are of identical thickness and species.
3. Edge distances, end distances and spacing are sufficient to develop full design values (see Section 2336.5).

The nominal bolt design values,  $Z$ , shall be the lesser of:

$$Z = \frac{D t_m F_{em}}{4K_{\Theta}} \quad \text{MODE I}_m \text{ (36-8)}$$

$$Z = \frac{D t_s F_{es}}{2K_{\Theta}} \quad \text{MODE I}_s \text{ (36-9)}$$

$$Z = \frac{k_3 D t_s F_{em}}{1.6(2 + R_e)K_{\Theta}} \quad \text{MODE III}_s \text{ (36-10)}$$

$$Z = \frac{D^2}{1.6K_{\Theta}} \sqrt{\frac{2 F_{em} F_{yb}}{3(1 + R_e)}} \quad \text{MODE IV (36-11)}$$

**WHERE:**

in which  $k_3 = -1 + \sqrt{\frac{2(1 + R_e)}{R_e} + \frac{2F_{yb}(2 + R_e)D^2}{3F_{em}t_s^2}}$

$D$  = nominal bolt diameter, inches (mm).

$F_{em}$  = dowel bearing strength of main (center) member, pounds per square inch (N/mm<sup>2</sup>) (see Table 23-III-G).

$F_{es}$  = dowel bearing strength of side members, pounds per square inch (N/mm<sup>2</sup>) (see Table 23-III-G).

$F_{yb}$  = bending yield strength of bolt, psi (N/mm<sup>2</sup>).

$K_\theta = 1 + \theta_{\max}/360^\circ$ .

$R_e = F_{em}/F_{es}$ .

$t_m$  = thickness of main (center) member, inches (mm).

$t_s$  = thickness of side member, inches (mm).

$\theta_{\max}$  = maximum angle of load to grain ( $0^\circ \leq \theta \leq 90^\circ$ ) for any member in a connection.

Tables 23-III-N and 23-III-P provide nominal design values for various double shear bolted connections with wood side members. Nominal bolt design values,  $Z$ , shall be multiplied by all applicable adjustment factors (see Table 23-III-A) to obtain allowable bolt design values,  $Z'$ . Design values for one species of wood shall be permitted to be used for other species having the same or higher dowel bearing strength,  $F_e$  (see Table 23-III-G).

**2336.3.2 Wood-to-metal connections.** Nominal bolt design values,  $Z$ , for symmetric double shear (three-member) connections with metal side plates shall be the lesser of Formulas (36-8), (36-10) and (36-11), with  $F_{es}$  = dowel bearing strength of the metal. Table 23-III-O provide nominal design values for various double shear bolted connections with steel side plates. Design values for one species of wood shall be permitted to be used for other species having the same or higher dowel bearing strength,  $F_e$  (see Table 23-III-G).

Nominal bolt design values,  $Z$ , for symmetric double shear (three-member) connections with metal main members shall be the lesser of Formulas (36-9), (36-10) and (36-11), with  $F_{em}$  = dowel bearing strength of the metal.

Metal parts shall be designed in accordance with accepted metal practices (see Section 2335.4.3).

**2336.4 Design Values for Multiple Shear Connections.** For a connection with four or more members (see Figure 23-III-6), or for an asymmetric three-member connection, each shear plane shall be evaluated as a single shear connection in accordance with the provisions of Sections 2336.2.1 and 2336.2.2. The nominal design value for the connection shall be the lowest nominal design value for any single shear plane, multiplied by the number of shear planes.

**2336.5 Placement of Bolts.**

**2336.5.1 Terminology.** Edge distance is the distance from the edge of a member to the center of the nearest bolt, measured perpendicular to grain. When a member is loaded perpendicular to grain, the loaded edge shall be defined as the edge toward which the load is acting. The unloaded edge shall be defined as the edge opposite the loaded edge (see Figure 23-III-7).

End distance is the distance measured parallel to grain from the square-cut end of a member to the center of the nearest bolt (see Figure 23-III-7).

Spacing is the distance between centers of bolts measured along a line joining their centers (see Figure 23-III-7).

A row of bolts is defined as two or more bolts aligned with the direction of load (see Figure 23-III-7).

**2336.5.2 Geometry factor,  $C_{\Delta}$ .** Nominal design values are for bolts with edge distance, end distance and spacing greater than or equal to the minimum required for full design value. When the end distance or spacing provided is less than the minimum required for full design value, nominal design values shall be multiplied by the smallest applicable geometry factor,  $C_{\Delta}$ , determined from the end distance and spacing requirements for bolts (see Sections 2336.5.4 and 2336.5.5). The smallest geometry factor for any bolt in a group shall apply to all bolts in the group. For multiple shear connections or for asymmetric three-member connections, the smallest geometry factor,  $C_{\Delta}$ , for any shear plane shall apply to all bolts in the connection.

**2336.5.3 Edge distance.** Minimum edge distances for bolts loaded parallel or perpendicular to grain shall be as follows:

#### EDGE DISTANCE REQUIREMENTS FOR BOLTS

<u>Direction of Loading</u>	<u>Minimum Edge Distance</u>
Parallel to grain:	
when $l/D \leq 6$	1.5D
when $l/D > 6$	1.5D or $1/2$ the spacing between rows, whichever is greater
Perpendicular to grain:	
loaded edge	4D
unloaded edge	1.5D

The  $l/D$  ratio used to determine the minimum edge distance shall be the lesser of:

1.  $\frac{\text{length of bolt in main member}}{D} = \frac{l_m}{D}$
2.  $\frac{\text{length of bolt in side member(s)}}{D} = \frac{l_s}{D}$

Designs with heavy or medium loads suspended below the neutral axis of a beam should be avoided (see Section 2335.3).

**2336.5.4 End distance.** Minimum end distances for bolts loaded parallel or perpendicular to grain are provided in Table 23-III-H.

When the actual end distance for parallel- or perpendicular-to-grain loading is greater than or equal to the minimum end distance for reduced design value, but less than the minimum end distance for full design value, the geometry factor,  $C_{\Delta}$ , shall be determined as follows:

$$C_{\Delta} = \frac{\text{actual end distance}}{\text{minimum end distance for full design values}}$$

For loading at an angle to the bolt axis, the minimum shear area for full design value shall be equivalent to the shear area for a parallel member connection with minimum end distance for full design value (see Section 2336.5.1 and Figure 23-III-4). The minimum shear area for reduced design value shall be equivalent to one half the minimum shear area for full design value. When the actual shear area is greater than or equal to the minimum shear area for reduced design value, but less than the minimum shear area for full design value, the geometry factor,  $C_{\Delta}$ , shall be determined as follows:

$$C_{\Delta} = \frac{\text{actual shear distance}}{\text{minimum shear distance for full design values}}$$

**2336.5.5 Spacing between bolts in a row.** Minimum spacing between bolts in a row for parallel or perpendicular to grain loading is provided in Table 23-III-I.

When the actual spacing between bolts in a row for parallel- or perpendicular-to-grain loading is greater than or equal to the minimum spacing for reduced design value, but less than the minimum spacing for full design value, the geometry factor,  $C_{\Delta}$ , shall be determined as follows:

$$C_{\Delta} = \frac{\text{actual spacing}}{\text{minimum spacing for full design value}}$$

**2336.5.6 Spacing between rows of bolts.** Minimum spacing between rows of bolts for parallel- or perpendicular-to-grain loading shall be as follows:

**SPACING REQUIREMENTS BETWEEN ROWS OF BOLTS**

<u>Direction of Loading</u>	<u>Minimum Spacing</u>
Parallel to grain	1.5D
Perpendicular to grain:	
when $l/D = 2$	2.5D
when $2 < l/D < 6$	$(5l + 10D)/8$
when $l/D \geq 6$	5D

The  $l/D$  ratio used to determine the minimum spacing between rows of bolts shall be the lesser of:

1.  $\frac{\text{length of bolt in main member}}{D} = \frac{l_m}{D}$
2.  $\frac{\text{length of bolt in side member(s)}}{D} = \frac{l_s}{D}$

The spacing between outer rows of bolts paralleling the member on a single splice plate shall not exceed 5 inches (127 mm) (see Figure 23-III-8).

**2336.5.7 Multiple bolts.** When a connection contains two or more bolts the group action factor,  $C_g$ , shall be as specified in Section 2335.5.6 and the total allowable design value for the connection shall be as specified in Section 2335.4.2.

Bolts should be staggered symmetrically in members loaded perpendicular to grain (see Section 2335.5.6 for special design provisions when bolts are staggered).

When a bolted connection is loaded at an angle to grain, the gravity axis of each member shall pass through the center of resistance of the group of bolts to ensure uniform stress in the main member and a uniform distribution of load to all bolts.

**SECTION 2337 — LAG SCREWS**

**2337.1 Scope.**

**2337.1.1 General.** Allowable loads for lag screws given in this standard are the maximum for normal loading. Pertinent adjustment of stresses and provisions of Division I for lumber, except as otherwise provided in this standard, apply likewise for loads for lag screws given in this standard.

**2337.1.2 Fabrication and assembly.** Lead holes for lag screws shall be bored as follows:

1. The clearance hole for the shank shall have the same diameter as the shank, and the same depth of penetration as the length of unthreaded shank.

2. The lead hole for the threaded portion shall have a diameter equal to 65 percent to 85 percent of the shank diameter in wood with  $G > 0.6$ , 60 percent to 75 percent in wood with  $0.5 < G \leq 0.6$ , and 40 percent to 70 percent in wood with  $G \leq 0.5$  (see Table 23-III-R) and a length equal to at least the length of the threaded portion. The larger percentile figure in each range shall apply to lag screws of greater diameters.

Lead holes or clearance holes shall not be required for  $3/8$ -inch (9.5 mm) and smaller diameter lag screws loaded primarily in withdrawal in wood with  $G \leq 0.5$  (see Table 23-III-R), provided that edge distances, end distances and spacing are sufficient to prevent unusual splitting.

The threaded portion of the lag screw shall be inserted in its lead hole by turning with a wrench, not by driving with a hammer.

Soap or other lubricant shall be used on the lag screws or in the lead holes to facilitate insertion and prevent damage to the lag screw.

### 2337.2 Withdrawal Design Values.

**2337.2.1 Withdrawal from side grain.** Table 23-III-S contains nominal withdrawal design values for a single lag screw inserted in side grain, with the lag screw axis perpendicular to the wood fibers. The withdrawal design value for a lag screw depends on the specific gravity of the species (see Table 23-III-R). Tabulated nominal design values,  $W$ , shall be multiplied by all applicable modification factors (see Table 23-III-A) to obtain allowable design values,  $W'$ .

**2337.2.2 End grain factor,  $C_{eg}$ .** Lag screws should not be loaded in withdrawal from end grain. When this condition cannot be avoided, the tabulated nominal withdrawal design values,  $W$ , shall be multiplied by the end grain factor,  $C_{eg} = 0.75$ .

**2337.2.3 Tensile strength of lag screw.** When lag screws are loaded in withdrawal, the allowable tensile strength of the lag screw at the net (root) section shall not be exceeded (see Section 2335.4.3).

### 2337.3 Lateral Design Values.

**2337.3.1 Wood-to-wood connections.** For single shear (two-member) wood-to-wood connections (see Figure 23-III-22) where:

1. The lag screw is inserted in the side grain of the main member with the lag screw axis perpendicular to the wood fibers.
2. Edge distances, end distances and spacing are sufficient to develop full design values (see Section 2337.4).
3. The depth of lag screw penetration in the main member is greater than or equal to the minimum penetration required for reduced design values.
4. Lag screw thread length is as specified in Table 23-III-UU (for lag screws with thread length greater than that specified in Table 23-III-UU, nominal lateral design values shall be permitted to be determined using  $D$  = root diameter of threaded portion of lag screw).

The nominal lag screw lateral design values,  $Z$ , shall be the lesser of:

$$Z = \frac{D t_s F_{es}}{4K_{\theta}} \quad \text{MODE I}_s \text{ (37-1)}$$

$$Z = \frac{k D t_s F_{em}}{2.8(2 + R_e)K_{\theta}} \quad \text{MODE III}_s \text{ (37-2)}$$

$$Z = \frac{D^2}{3K_{\theta}} \sqrt{\frac{1.75 F_{em} F_{yb}}{3(1 + R_e)}} \quad \text{MODE IV (37-3)}$$

#### WHERE:

$D$  = unthreaded shank diameter of lag screw, inches (mm).

$F_{em}$  = dowel bearing strength of main member (member holding point), pounds per square inch (N/mm<sup>2</sup>) (see Table 23-III-R).

$F_{es}$  = dowel bearing strength of side member, pounds per square inch (N/mm<sup>2</sup>) (see Table 23-III-R).

$F_{yb}$  = bending yield strength of lag screw, pounds per square inch (N/mm<sup>2</sup>).

$$k = -1 + \sqrt{\frac{2(1 + R_e)}{R_e} + \frac{F_{yb}(2 + R_e)D^2}{2F_{em} t_s^2}}$$

$$K_{\Theta} = 1 + \Theta_{\max}/360^{\circ}.$$

$$R_e = F_{em}/F_{es}$$

$t_s$  = thickness of side member, inches (mm).

$\Theta$  = maximum angle of load to grain ( $0^{\circ} \leq \Theta \leq 90^{\circ}$ ) for any member in a connection.

When a member is loaded at an angle to grain, the dowel bearing strength,  $F_{e\Theta}$ , for the member shall be determined as follows:

$$F_{e\Theta} = \frac{F_{e\parallel} F_{e\perp}}{F_{e\parallel} \sin^2 \Theta + F_{e\perp} \cos^2 \Theta} \quad (37-4)$$

**WHERE:**

$\Theta$  = angle between direction of load and direction of grain (longitudinal axis of member).

Table 23-III-T provides nominal lateral design values for various cut thread lag screw connections with wood side members. Nominal lag screw design values,  $Z$ , shall be multiplied by all applicable adjustment factors (see Table 23-III-A) to obtain allowable lag screw design values,  $Z'$ . Design values for one species of wood shall be permitted to be used for other species having the same or higher dowel bearing strength,  $F_e$  (see Table 23-III-R).

**2337.3.2 Wood-to-metal connections.** Nominal lag screw lateral design values,  $Z$ , for single shear (two-member) connections with metal side plates shall be the lesser of Formulas (37-2) and (37-3), with  $F_{es}$  = bearing strength of the metal. Table 23-III-U provides nominal lateral design values for various cut thread lag screw connections with steel side plates.

Nominal lag screw design values,  $Z$ , shall be multiplied by all applicable adjustment factors (see Table 23-III-A) to obtain allowable lag screw design values,  $Z'$ . Design values for one species of wood shall be permitted to be used for other species having the same or higher dowel bearing strength,  $F_e$  (see Table 23-III-R).

Metal parts shall be designed in accordance with accepted metal practices (see Section 2335.4.3).

**2337.3.3 Penetration depth factor,  $C_d$ .** Nominal lag screw lateral design values are based on lag screw penetration (not including the length of the tapered tip) into the main member of approximately eight times the shank diameter,  $p = 8D$ . The minimum lag screw penetration into the main member for reduced design value shall be four times the shank diameter,  $p_{\min} = 4D$ . When  $4D \leq p \leq 8D$ , nominal lateral design values shall be multiplied by the following penetration depth factor:

$$C_d = \frac{p}{8D} \leq 1.0 \quad (37-5)$$

**2337.3.4 End grain factor,  $C_{eg}$ .** When lag screws are inserted in the end grain of the main member, with the lag screw axis parallel to the wood fibers, nominal lateral design values shall be determined in accordance with the provisions of Sections 2337.3.1 and 2337.3.2 with  $F_{em} = F_{e\perp}$ , and shall be multiplied by the end grain factor,  $C_{eg} = 0.67$ .

**2337.3.5 Combined lateral and withdrawal loads.** When a lag screw is subjected to combined lateral and withdrawal loading, as when the lag screw is inserted perpendicular to the fiber and the load acts at an angle  $\alpha$  (see Figure 23-III-9), the allowable design value shall be determined as follows:

$$Z_{\alpha}' = \frac{W' p Z'}{W' p \cos^2 \alpha + Z' \sin^2 \alpha} \quad (37-6)$$

**WHERE:**

$\alpha$  = angle between wood surface and direction of applied load.

$p$  = length of thread penetration in main member.

**2337.4 Placement of Lag Screws.**

**2337.4.1 Geometry factor, edge distance, end distance, spacing.** Minimum edge distances, end distances, spacing and associated geometry factors,  $C_{\Delta}$ , for lag screws shall be the same as for bolts with a diameter equal to the shank diameter of the lag screw (see Section 2336.5).

**2337.4.2 Multiple lag screws.** When a connection contains two or more lag screws the group action factor,  $C_g$ , shall be as specified in Section 2335.5.6 and the total allowable design value for the connection shall be as specified in Section 2335.4.2.

**SECTION 2338 — SPLIT RING AND SHEAR PLATE CONNECTORS****2338.1 General.**

**2338.1.1 Terminology.** A connector unit shall be defined as one of the following:

1. One split ring with its bolt or lag screw in single shear (see Figure 23-III-10).
2. Two shear plates used back to back in the contact faces of a wood-to-wood connection with their bolt or lag screw in single shear (see Figures 23-III-11 and 23-III-12).
3. One shear plate with its bolt or lag screw in single shear used in conjunction with a steel strap or shape in a wood-to-metal connection (see Figures 23-III-11 and 23-III-12).

**2338.1.2 Quality of split ring and shear plate connectors.** Design provisions and design values herein apply to split ring and shear plate connectors of the following quality:

1. Split rings manufactured from SAE 1010 hot-rolled carbon steel. Each ring shall form a closed true circle with the principal axis of the cross section of the ring metal parallel to the geometric axis of the ring. The ring shall fit snugly in the precut groove. This may be accomplished with a ring, the metal section of which is beveled from the central portion toward the edges to a thickness less than at midsection, or by any other method which will accomplish equivalent performance. It shall be cut through in one place in its circumference to form a tongue and slot (see Figure 23-III-10).

2. Shear plate connectors:

- 2.1 Two and five-eighths-inch (66.7 mm) pressed-steel-type—Pressed steel shear plates manufactured from SAE 1010 hot-rolled carbon steel. Each plate shall be a true circle with a flange around the edge, extending at right angles to the face of the plate and extending from one face only, the plate portion having a central bolt hole, with an integral hub concentric to the hole or without an integral hub, and two small perforations on opposite sides of the hole and midway from the center and circumference (see Figure 23-III-11).

- 2.2 Four-inch (101.6 mm) malleable-iron-type—Malleable iron shear plates manufactured according to Grade 32510 of ASTM A 47. Each casting shall consist of a perforated round plate with a flange around the edge extending at right angles to the face of the plate and projecting from one face only, the plate portion having a central bolt hole with an integral hub extending from the same face as the flange (see Figure 23-III-12).

Dimensions for typical split ring and shear plate connectors are provided in Table 23-III-VV. Dimensional tolerances of split ring and shear plate connectors shall not be greater than those conforming to standard practices for the machine operations involved in manufacturing the connectors.

Bolts used with split ring and shear plate connectors shall conform to Section 2336.1.

When lag screws are used in place of bolts, the lag screw shall conform to Section 2337.1 and the shank of the lag screw shall have the same diameter as the bolt specified for the split ring or shear plate connector (see Tables 23-III-W and 23-III-X). The lag screw shall have a cut thread, rather than a rolled thread.

**2338.1.3 Fabrication and assembly.** The grooves, daps and bolt holes specified in Table 23-III-VV shall be accurately cut or bored, and shall be oriented in contacting faces. Since split ring

and shear plate connectors from different manufacturers may differ slightly in shape or cross section, cutter heads shall be designed to produce daps and grooves conforming accurately to the dimensions and shape of the particular split ring or shear plate connectors used.

When lag screws are used in place of bolts, the hole for the unthreaded shank shall be the same diameter as the shank. The diameter of the hole for the threaded portion of the lag screw shall be approximately 70 percent of the shank diameter, or as specified in Section 2337.1.2.

In installation of split ring or shear plate connectors and bolts or lag screws, a nut shall be placed on each bolt, and washers, not smaller than the size specified in Table 23-III-VV, shall be placed between the outside wood member and the bolt or lag screw head and between the outside wood member and nut. When an outside member of a shear plate connection is a steel strap or shape, the washer may be omitted, except when desirable to extend bolt or lag screw length to prevent the metal plate or shape from bearing on the threaded portion of the bolt or lag screw.

Tabulated nominal design values for split ring and shear plate connectors are based on the assumption that the faces of the members are brought into contact when the connector units are installed, and allow for seasonal variations after the wood has reached the moisture content normal to the conditions of service. When split ring or shear plate connectors are installed in wood which is not seasoned to the moisture content normal to the conditions of service, the connections shall be tightened by turning down the nuts periodically until moisture equilibrium is reached.

#### 2338.2 Design Values.

**2338.2.1 Tabulated nominal design values.** Tables 23-III-W and 23-III-X contain design values for a single split ring or shear plate connector unit with bolt in single shear, installed in the side grain of two wood members with sufficient member thicknesses, edge distances, end distances, and spacing to develop tabulated nominal design values. Tabulated nominal design values ( $P$ ,  $Q$ ) shall be multiplied by all applicable modification factors (see Table 23-III-A) to obtain allowable design values ( $P'$ ,  $Q'$ ).

Allowable design values ( $P'$ ,  $Q'$ ) for shear plate connectors shall not exceed the limiting design values specified in Footnote 2 of Table 23-III-X. The limiting design values in Footnote 2 of Table 23-III-X shall not be multiplied by modification factors in this specification since they are based on strength of metal rather than strength of wood (see Section 2335.4.3).

**2338.2.2 Thickness of wood members.** Tabulated nominal design values shall not be used for split ring or shear plate connectors installed in any piece of wood of a net thickness less than the minimum specified in Tables 23-III-W and 23-III-X.

Design values for split ring or shear plate connectors installed in any piece of wood of net thickness intermediate between the minimum thickness and that required for maximum design value, as specified in Tables 23-III-W and 23-III-X, shall be obtained by linear interpolation.

**2338.2.3 Penetration depth factor,  $C_d$ .** When lag screws instead of bolts are used with split ring or shear plate connectors, tabulated nominal design values shall be multiplied by the appropriate penetration depth factor,  $C_d$ , specified in Table 23-III-Y. Lag screw penetration into the member receiving the point shall not be less than the minimum penetration for reduced design value specified in Table 23-III-Y. When the actual lag screw penetration into the member receiving the point is greater than the minimum penetration for reduced design value, but less than the minimum penetration for full design value, the penetration depth factor,  $C_d$ , shall be determined by linear interpolation. The penetration depth factor shall not exceed unity,  $C_d \leq 1.0$ .

**2338.2.4 Metal plate factor,  $C_{st}$ .** When metal side members are used in place of wood side members, the tabulated nominal design values parallel to grain,  $P$ , for 4-inch (102 mm) shear plate connectors shall be multiplied by the appropriate metal plate factor specified in Table 23-III-Z.

The allowable design values parallel to grain,  $P'$ , shall not exceed the limiting design values given in Footnote 2 of Table 23-III-X.

**2338.2.5 Load at angle to grain.** When a load acts in the plane of the wood surface at an angle to grain other than 0 degree or 90 degrees, the allowable design value,  $N'$ , for a split ring or shear plate connector unit shall be determined as follows:

$$N' = \frac{P'Q'}{P' \sin^2 \Theta + Q' \cos^2 \Theta} \quad (38-1)$$

**WHERE:**

$\Theta$  = angle between direction of load and direction of grain (longitudinal axis of member).

Allowable design values at an angle to grain,  $N'$ , for shear plate connectors shall not exceed the limiting design values specified in Footnote 2 of Table 23-III-X.

**2338.2.6 Split ring and shear plate connectors in end grain.** When split ring or shear plate connectors are installed in a surface that is not parallel to the general direction of the grain of the member, such as the end of a square-cut member, or the sloping surface of a member cut at an angle to its axis, or the surface of a glued-laminated timber cut at an angle to the direction of the laminations, the following terminology shall apply:

**AXIS OF CUT** is the direction of a sloping surface relative to the general direction of the wood fibers. For a sloping cut symmetrical about one of the major axes of the member, as in Figures 23-III-13, 23-III-16, 23-III-17 and 23-III-18, the axis of cut is parallel to a major axis. For an asymmetrical sloping surface (i.e., one that slopes relative to both major axes of the member), the axis of cut is the direction of a line defining the intersection of the sloping surface with any plane that is both normal to the sloping surface and also is aligned with the general direction of the wood fibers (see Figure 23-III-14).

**SIDE GRAIN SURFACE** is a surface parallel to the general direction of the wood fibers ( $\alpha = 0$  degree), such as the top, bottom and sides of a straight beam.

**SLOPING SURFACE** is a surface cut at an angle,  $\alpha$ , other than 0 degree or 90 degrees to the general direction of the wood fibers.

**SQUARE-CUT SURFACE** is a surface perpendicular to the general direction of the wood fibers ( $\alpha = 90$  degrees).

$N'_\alpha$  = allowable design value for a split ring or shear plate connector unit in a sloping surface, when direction of load is at an angle  $\phi$  from the axis of cut.

$P'$  = allowable design value for a split ring or shear plate connector unit in a side grain surface, loaded parallel to grain ( $\alpha = 0$  degree,  $\phi = 0$  degree).

$P'_\alpha$  = allowable design value for a split ring or shear plate connector unit in a sloping surface, loaded in a direction parallel to the axis of cut ( $0$  degree  $< \alpha < 90$  degrees,  $\phi = 0$  degree).

$Q'$  = allowable design value for a split ring or shear plate connector unit in a side grain surface, loaded perpendicular to grain ( $\alpha = 0$  degree,  $\phi = 90$  degrees).

$Q'_\alpha$  = allowable design value for a split ring or shear plate connector unit in a sloping surface, loaded in a direction perpendicular to the axis of cut ( $0$  degree  $< \alpha < 90$  degrees,  $\phi = 90$  degrees).

$Q'_{90}$  = allowable design value for a split ring or shear plate connector unit in a square-cut surface, loaded in any direction in the plane of the surface ( $\alpha = 90$  degrees).

$\alpha$  = the least angle formed between a sloping surface and the general direction of the wood fibers (i.e., the acute angle between the axis of cut and the general direction of the fibers). Sometimes called the slope of the cut. See Figures 23-III-13 through 23-III-18.

$\phi$  = the angle between the direction of applied load and the axis of cut of a sloping surface, measured in the plane of the sloping surface (see Figure 23-III-18).

When split ring or shear plate connectors are installed in square-cut end grain or sloping surfaces, allowable design values shall be determined as follows (see Section 2335.4.2):

1. Square-cut surface; loaded in any direction ( $\alpha = 90$  degrees, see Figure 23-III-15).

$$Q'_{90} = 0.60 Q'$$

2. Sloping surface, loaded parallel to axis of cut ( $0$  degree  $< \alpha < 90$  degrees,  $\phi = 0$  degree, see Figure 23-III-16).

$$P'_\alpha = \frac{P'Q'_{90}}{P' \sin^2 \alpha + Q'_{90} \cos^2 \alpha}$$

3. Sloping surface; loaded perpendicular to axis of cut ( $0$  degree  $< \alpha < 90$  degrees,  $\phi = 90$  degrees, see Figure 23-III-17).

$$Q'_\alpha = \frac{Q'Q'_{90}}{Q' \sin^2 \alpha + Q'_{90} \cos^2 \alpha}$$

4. Sloping surface; loaded at angle  $\phi$  to axis of cut ( $0$  degree  $< \alpha < 90$  degrees,  $0$  degree  $< \phi < 90$  degrees, see Figure 23-III-18).

$$N'_\alpha = \frac{P'_\alpha Q'_\alpha}{P'_\alpha \sin^2 \phi + Q'_\alpha \cos^2 \phi}$$

### 2338.3 Placement of Split Ring and Shear Plate Connectors.

**2338.3.1 Terminology.** Edge distance is the distance from the edge of a member to the center of the nearest split ring or shear plate connector, measured perpendicular to grain. When a member is loaded perpendicular to grain, the loaded edge shall be defined as the edge toward which the load is acting. The unloaded edge shall be defined as the edge opposite the loaded edge (see Figure 23-III-19).

End distance is the distance measured parallel to grain from the square-cut end of a member to the center of the nearest split ring or shear plate connector (see Figure 23-III-19). If the end of a member is not cut at right angles to its length, the end distance, measured parallel to grain from any point on the center half of the transverse connector diameter, shall not be less than the end distance required for a square-cut member. In no case shall the perpendicular distance from the center of a connector to the sloping end cut of a member be less than the required edge distance (see Figure 23-III-20).

Spacing is the distance between centers of split ring or shear plate connectors measured along a line joining their centers (see Figure 23-III-19).

**2338.3.2 Geometry factor,  $C_\Delta$ .** Tabulated nominal design values are for split ring and shear plate connectors with edge distance, end distance and spacing greater than or equal to the minimum required for full design value. When the edge distance, end distance or spacing provided is less than the minimum required for full design value, tabulated nominal design values shall be multiplied by the smallest applicable geometry factor,  $C_\Delta$ , determined from the edge distance, end distance and spacing requirements for split ring and shear plate connectors (see Section 2338.3.3). The smallest geometry factor for any split ring or shear plate connector in a group shall apply to all split ring and shear plate connectors in the group.

### 2338.3.3 Edge distance.

**2338.3.3.1 Members loaded parallel or perpendicular to grain.** Minimum edge distances and associated geometry factors,  $C_\Delta$ , for split ring and shear plate connectors installed in side grain and loaded parallel or perpendicular to grain are provided in Table 23-III-AA. When the actual loaded edge distance is greater than or equal to the minimum loaded edge distance for reduced design value, but less than the minimum loaded edge distance for full design value, the geometry factor,  $C_\Delta$ , shall be determined by linear interpolation.

**2338.3.3.2 Members loaded at angle to grain.** When members are loaded at an angle to grain,  $\Theta$ , other than 0 degree or 90 degrees, the minimum loaded edge distances for reduced design value and the minimum unloaded edge distances in Table 23-III-AA shall apply for all angles of load to grain. Minimum loaded edge distances for full design value shall be determined as follows:

1. When 45 degrees  $\leq \Theta \leq$  90 degrees, the minimum loaded edge distance for full design value for perpendicular-to-grain loading shall apply.
2. When 0 degrees  $\leq \Theta <$  45 degrees, the minimum loaded edge distance for full design value shall be determined by linear interpolation between the minimum loaded edge distance for reduced design value and the minimum loaded edge distance for full design value for perpendicular-to-grain loading.

When a member is loaded at an angle to grain,  $\Theta$ , other than 0 degree or 90 degrees, the geometry factor,  $C_A$ , based on edge distance requirements shall apply to both the tabulated nominal parallel and perpendicular-to-grain design values ( $P$ ,  $Q$ ).

#### **2338.3.4 End distance.**

**2338.3.4.1 Members loaded parallel or perpendicular to grain.** Minimum end distances and associated geometry factor,  $C_A$ , for split ring and shear plate connectors installed in side grain and loaded parallel or perpendicular to grain are provided in Table 23-III-AA. When the actual end distance is greater than or equal to the minimum end distance for reduced design value, but less than the minimum end distance for full design value, the geometry factor,  $C_A$ , shall be determined by linear interpolation.

**2338.3.4.2 Members loaded at angle to grain.** When members are loaded at an angle to grain,  $\Theta$ , other than 0 degree or 90 degrees, minimum end distances for reduced design value and minimum end distances for full design value shall be determined by linear interpolation between tabulated end distances for parallel and perpendicular-to-grain loading.

#### **2338.3.5 Spacing.**

**2338.3.5.1 Members loaded parallel or perpendicular to grain.** Minimum parallel and perpendicular-to-grain spacings and associated geometry factor,  $C_A$ , for split ring and shear plate connectors installed in side grain and loaded parallel or perpendicular to grain are provided in Table 23-III-AA. When the line joining the centers of two adjacent split ring or shear plate connectors is at an angle to grain other than 0 degree or 90 degrees, the minimum spacing for reduced design value and the minimum spacing for full design value shall be determined in accordance with an approved graphical method. When the actual spacing between split ring or shear plate connectors is greater than the minimum spacing for reduced design value, but less than the minimum spacing for full design value, the geometry factor,  $C_A$ , shall be determined by linear interpolation.

**2338.3.5.2 Members loaded at angle to grain.** When members are loaded at an angle to grain,  $\Theta$ , other than 0 degree or 90 degrees, the minimum spacing for reduced design value and minimum spacing for full design value shall be determined in accordance with an approved graphical method.

**2338.3.6 Split ring and shear plate connectors in end grain.** The provisions for edge distance, end distance and spacing given in Sections 2338.3.3, 2338.3.4 and 2338.3.5 for split ring and shear plate connectors installed in side grain shall apply to split ring and shear plate connectors installed in square-cut surfaces and sloping surfaces as follows (see Section 2338.2.6 for definitions and terminology):

1. Square-cut surface, loaded in any direction—apply provisions for perpendicular-to-grain loading.
2. Sloping surface with  $\alpha$  from 45 degrees to 90 degrees, loaded in any direction—apply provisions for perpendicular-to-grain loading.
3. Sloping surface with  $\alpha$  less than 45 degrees, loaded parallel to axis of cut—apply provisions for parallel-to-grain loading.

4. Sloping surface with  $\alpha$  less than 45 degrees, loaded perpendicular to axis of cut—apply provisions for perpendicular-to-grain loading.

5. Sloping surface with  $\alpha$  less than 45 degrees, loaded at angle  $\phi$  to axis of cut—apply provisions for members loaded at angles to grain other than 0 degree or 90 degrees.

When split ring or shear plate connectors are installed in end grain, the members shall be designed for shear parallel to grain in accordance with Division I.

**2338.3.7 Multiple split ring or shear plate connectors.** When a connection contains:

1. Two or more split ring or shear plate connector units of the same size installed in two or more contact faces with the split ring or shear plate connectors concentric with the same bolt axis, or

2. Two or more split ring or shear plate connector units on separate bolts or lag screws, the group action factor,  $C_g$ , shall be as specified in Section 2335.5.6 and the total allowable design value for the connection shall be as specified in Section 2335.4.3.

If grooves for two sizes of split rings are cut concentric in the same wood surface, split ring connectors shall be installed in both grooves and the design value shall be taken as the design value for the larger split ring connector.

## SECTION 2339 — WOOD SCREWS

### 2339.1 General.

**2339.1.1 Scope.** For wood screw joints with stress-grade lumber and the wood screws defined in this standard, the provisions of this part and the tabulated values apply.

**2339.1.2 Fabrication and assembly.** Lead holes for wood screws loaded in withdrawal shall have a diameter equal to approximately 90 percent of the wood screw root diameter in wood with  $G > 0.6$ , and approximately 70 percent of the wood screw root diameter in wood with  $0.5 < G \leq 0.6$  (see Table 23-III-SS). The wood screw may be inserted without a lead hole in wood with  $G \leq 0.5$  (see Table 23-III-BB).

Lead holes for wood screws loaded laterally shall be bored as follows:

1. For wood with  $G > 0.6$  (see Table 23-III-BB), the part of the lead hole receiving the shank shall have about the same diameter as the shank, and that receiving the threaded portion shall have about the same diameter as the screw at the root of the thread.

2. For  $G \leq 0.6$  (see Table 23-III-BB), the part of the lead hole receiving the shank shall be about seven eighths the diameter of the shank and that receiving the threaded portion shall be about seven eighths the diameter of the screw at the root of the thread.

The wood screw shall be inserted in its lead hole by turning with a screwdriver or other tool, not by driving with a hammer.

Soap or other lubricant shall be used on the wood screws or in the lead holes to facilitate insertion and to prevent damage to the wood screw.

### 2339.2 Withdrawal Design Values.

**2339.2.1 Withdrawal from side grain.** Table 23-III-CC contains nominal withdrawal design values for a single wood screw (cut thread or rolled thread) inserted in side grain, with the wood screw axis perpendicular to the wood fibers. The withdrawal design value for a wood screw depends on the specific gravity of the species (see Table 23-III-BB). Tabulated nominal design values,  $W$ , shall be multiplied by all applicable modification factors (see Table 23-III-A) to obtain allowable design values,  $W'$ .

**2339.2.2 Withdrawal from end grain.** Wood screws shall not be loaded in withdrawal from end grain of wood.

**2339.2.3 Tensile strength of wood screws.** When wood screws are loaded in withdrawal, the allowable tensile strength of the wood screw at net (root) section shall not be exceeded (see Section 2335.4.3).

**2339.3 Lateral Design Values.**

**2339.3.1 Wood-to-wood connections.** For single shear (two-member) wood-to-wood connections (see Figure 23-III-22) where:

1. The wood screw is inserted in the side grain of the main member with the wood screw axis perpendicular to the wood fibers.

2. The depth of wood screw penetration in the main member is sufficient to develop full design values (see Section 2339.3.3). The nominal wood screw lateral design values,  $Z$ , shall be the lesser of:

$$Z = \frac{D t_s F_{es}}{K_D} \quad \text{MODE I}_s \text{ (39-1)}$$

$$Z = \frac{k D t_s F_{em}}{K_D(2 + R_e)} \quad \text{MODE III}_s \text{ (39-2)}$$

$$Z = \frac{D^2}{K_D} \sqrt{\frac{1.75 F_{em} F_{yb}}{3(1 + R_e)}} \quad \text{MODE IV (39-3)}$$

**WHERE:**

$D$  = unthreaded shank diameter of wood screw, inches (mm).

$F_{em}$  = dowel bearing strength of main member (member holding point), pounds per square inch (N/mm<sup>2</sup>) (see Table 23-III-BB).

$F_{es}$  = dowel bearing strength of side member, pounds per square inch (N/mm<sup>2</sup>) (see Table 23-III-BB).

$F_{yb}$  = bending yield strength of wood screw, pounds per square inch (N/mm<sup>2</sup>).

$$k = -1 + \sqrt{\frac{2(1 + R_e)}{R_e} + \frac{F_{yb}(2 + R_e)D^2}{2F_{em} t_s^2}}$$

$K_D$  = 2.2 for  $D \leq 0.17$  inch (4.3 mm).

$K_D$  =  $10D + 0.5$  for  $0.17$  inch (4.3 mm)  $< D < 0.25$  inch (6.4 mm)

For SI:  $K_D = 0.38 D + 0.56$

$K_D$  = 3.0 for  $D \geq 0.25$  inch (6.4 mm)

$R_e = F_{em}/F_{es}$

$t_s$  = thickness of side member, inches (mm).

Table 23-III-DD provides nominal lateral design values,  $Z$ , for various cut thread wood screw connections with wood side members. Nominal wood screw design values,  $Z$ , shall be multiplied by all applicable modification factors (see Table 23-III-A) to obtain allowable wood screw design values,  $Z'$ . Design values for one species of wood shall be permitted to be used for other species having the same or higher dowel bearing strength,  $F_e$  (see Table 23-III-BB).

**2339.3.2 Wood-to-metal connections.** Nominal wood screw lateral design values,  $Z$ , for single shear (two-member) connections with metal side plates shall be the lesser of Formulas (39-2) and (39-3) with  $F_{es}$  = dowel bearing strength of the metal. Table 23-III-EE provides nominal lateral design values,  $Z$ , for various cut thread wood screw connections with steel side plates. Nominal wood screw design values,  $Z$ , shall be multiplied by all applicable adjustment factors (see Table 23-III-A) to obtain allowable wood screw design values,  $Z'$ . Design values for one species of wood shall be permitted to be used for other species having the same or higher dowel bearing strength,  $F_e$  (see Table 23-III-BB).

Metal parts shall be designed in accordance with accepted metal practices (see Section 2335.4.3).

**2339.3.3 Penetration depth factor,  $C_d$ .** Nominal wood screw lateral design values are based on wood screw penetration into the main member of approximately seven times the shank diameter,  $p = 7D$ . The minimum wood screw penetration into the main member for reduced design value shall be four times the shank diameter,  $p_{\min} = 4D$ . When  $4D \leq p < 7D$ , nominal lateral design values shall be multiplied by the following penetration depth factor:

$$C_d = \frac{p}{7D} \leq 1.0 \quad (39-4)$$

**2339.3.4 End grain factor,  $C_{eg}$ .** When wood screws are inserted in the end grain of the main member, with the wood screw axis parallel to the wood fibers, nominal lateral design values shall be multiplied by the end grain factor,  $C_{eg} = 0.67$ .

**2339.3.5 Combined lateral and withdrawal loads.** When a wood screw is subjected to combined lateral and withdrawal loading, as when the wood screw is inserted perpendicular to the fiber and the load acts at an angle ( $\alpha$ ) to the wood surface (see Figure 23-III-9), the allowable design value shall be determined as follows:

$$Z'_a = \frac{Z'(W'p)}{Z' \sin^2 \alpha + (W'p) \cos^2 \alpha} \quad (39-5)$$

**WHERE:**

- $p$  = length of thread penetration in main member.
- $\alpha$  = angle between wood surface and direction of applied load.

**2339.4 Placement of Wood Screws.**

**2339.4.1 Edge distance, end distance and spacing.** Edge distances, end distances and spacing for wood screws shall be sufficient to prevent splitting of the wood.

**2339.4.2 Multiple wood screws.** When a connection contains more than one wood screw, the total allowable design value for the connection shall be as specified in Section 2335.4.2.

**SECTION 2340 — NAILS AND SPIKES**

**2340.1 General.**

**2340.1.1 General provisions.** The following provisions apply to common wire nails and spikes, box nails and threaded, hardened-steel nails and spikes. They should be used when the structural design depends on specific design values for each nail (engineered construction). Nail specifications for engineered construction should include the minimum lengths and diameters of the nails and spikes to be used. When designing connections which do not depend on specific design values for nails, the nailing schedules specified in an approved standard shall be permitted to be used.

**2340.1.2 Quality of nails and spikes.** Common steel wire nails and spikes, box nails and threaded hardened-steel nails shall conform to the nominal sizes specified in Federal Specification FF-N-105B. Tabulated diameters apply to fasteners before application of any protective coating.

Threaded, hardened-steel nails and spikes covered herein are made of high carbon steel wire, headed, pointed, annularly or helically threaded, and heat treated and tempered to provide greater yield strength than for common wire nails of corresponding size.

**2340.1.3 Fabrication and assembly.** Nominal design values herein apply to nailed and spiked connections either with or without bored holes. When a bored hole is required to prevent splitting of wood, the diameter of the bored hole shall not exceed 90 percent of the nail or spike diameter for wood with  $G > 0.6$ , or 75 percent of the nail or spike diameter for wood with  $G \leq 0.6$  (see Table 23-III-FF).

Toenails shall be driven at an angle of approximately 30 degrees with the member and started approximately one third the length of the nail from the member end (see Figure 23-III-21).

### 2340.2 Withdrawal Design Values.

**2340.2.1 Withdrawal from side grain.** Table 23-III-GG contains nominal withdrawal design values for a single nail or spike driven in the side grain of the main member with the nail or spike axis perpendicular to the wood fibers. The withdrawal design value for a nail or spike depends on the specific gravity of the species (see Table 23-III-FF). Tabulated nominal design values,  $W$ , shall be multiplied by all applicable modification factors (see Table 23-III-A) to obtain allowable design values,  $W'$ .

**2340.2.2 Withdrawal from end grain.** Nails and spikes shall not be loaded in withdrawal from end grain of wood.

**2340.2.3 Toenail factor,  $C_m$ .** When toenailed connections are used, tabulated nominal withdrawal design values for the nails or spikes shall be multiplied by the toenail factor,  $C_m = 0.67$ . The moisture content factor,  $C_M$ , shall not apply for toenails loaded in withdrawal.

### 2340.3 Lateral Design Values.

**2340.3.1 Wood-to-wood connections.** For single shear (two-member) wood-to-wood connections (see Figure 23-III-22) where:

1. The nail or spike is driven in the side grain of the main member with the nail or spike axis perpendicular to the wood fibers.
2. The depth of nail or spike penetration in the main member is sufficient to develop full design values (see Section 2340.3.4).

The nominal nail or spike lateral design values,  $Z$ , shall be the lesser of:

$$Z = \frac{D t_s F_{es}}{K_D} \quad \text{MODE I}_s \text{ (40-1)}$$

$$Z = \frac{k_1 D p F_{em}}{K_D (1 + 2R_e)} \quad \text{MODE II}_m \text{ (40-2)}$$

$$Z = \frac{k_2 D t_s F_{em}}{K_D (2 + R_e)} \quad \text{MODE III}_s \text{ (40-3)}$$

$$Z = \frac{D^2}{K_D} \sqrt{\frac{2 F_{em} F_{yb}}{3(1 + R_e)}} \quad \text{MODE IV (40-4)}$$

#### WHERE:

$D$  = nail or spike diameter, inches (mm).

$F_{em}$  = dowel bearing strength of main member (member holding point), pounds per square inch (N/mm<sup>2</sup>) (see Table 23-III-FF).

$F_{es}$  = dowel bearing strength of side member, pounds per square inch (N/mm<sup>2</sup>) (see Table 23-III-FF).

$F_{yb}$  = bending yield strength of nail or spike, pounds per square inch (N/mm<sup>2</sup>).

$K_D$  = 2.2 for  $D \leq 0.17$  inch (4.3 mm).

$K_D$  =  $10D + 0.5$  for  $0.17$  inch (4.3 mm)  $< D < 0.25$  inch (6.4 mm)

$K_D$  = 3.0 for  $D \geq 0.25$  inch (6.4 mm)

$$k_1 = -1 + \sqrt{2(1 + R_e) + \frac{2F_{yb}(1 + 2R_e)D^2}{3F_{em} p^2}}$$

$$k_2 = -1 + \sqrt{\frac{2(1 + R_e)}{R_e} + \frac{2F_{yb}(2 + R_e)D^2}{3F_{em}t_s^2}}$$

$p$  = penetration of nail or spike in main member (member holding point), inches (mm).

$R_e = F_{em}/F_{es}$

$t_s$  = thickness of side member, inches (mm).

Tables 23-III-HH, 23-III-II, 23-III-JJ and 23-III-KK provide nominal lateral design values,  $Z$ , for common nail connections with wood side members. Nominal nail and spike design values,  $Z$ , shall be multiplied by all applicable modification factors (see Table 23-III-A) to obtain allowable nail and spike design values,  $Z'$ . Design values for one species of wood shall be permitted to be used for other species having the same or higher dowel bearing strength,  $F_e$  (see Table 23-III-FF).

**2340.3.2 Wood-to-metal connections.** Nominal nail and spike lateral design values,  $Z$ , for single shear (two-member) connections with metal side plates shall be the lesser of Formulas (40-2), (40-3) and (40-4) with  $F_{es}$  = dowel bearing strength of the metal. Tables 23-III-LL, 23-III-MM, 23-III-NN and 23-III-OO provide nominal lateral design values for common nail connections with steel side plates. Nominal nail and spike design values,  $Z$ , shall be multiplied by all applicable adjustment factors (see Table 23-III-A) to obtain allowable nail and spike design values,  $Z'$ . Design values for one species of wood shall be permitted to be used for other species having the same or higher dowel bearing strength  $F_e$  (see Table 23-III-FF).

Metal parts shall be designed in accordance with accepted metal practices (see Section 2335.4.3). These design provisions shall not preclude the use of wood-to-metal nailed connections where it can be demonstrated by full-scale or prototype loading tests that the connections can perform satisfactorily in their intended end uses (see Section 2335.1).

**2340.3.3 Double shear wood-to-wood connections.** Nominal nail and spike lateral design values,  $Z$ , for double shear (three-member) wood-to-wood connections with  $t_m > 6D$  shall be two times the lesser of the smallest nominal design value,  $Z$ , determined from Formulas (40-1), (40-2), (40-3) and (40-4), for each shear plane. The penetration depth factor,  $C_d$ , shall apply based on nail penetration in the third member (see Section 2340.3.4), except that  $C_d = 1.0$  when  $12d$  or smaller nails extend at least three diameters beyond the side member and are clinched, and side members are at least  $3/8$  inch (9.5 mm) thick.

**2340.3.4 Penetration depth factor,  $C_d$ .** Nominal nail and spike lateral design values are based on nail or spike penetration into the main member of approximately 12 times the nail or spike diameter,  $p = 12D$ . The minimum nail or spike penetration into the main member for reduced design value shall be six times the nail or spike diameter,  $p_{\min} = 6D$ . When  $6D \leq p < 12D$ , nominal lateral design values shall be multiplied by the following penetration depth factor:

$$C_d = \frac{p}{12D} \leq 1.0 \quad (40-5)$$

**2340.3.5 End grain factor,  $C_{eg}$ .** When nails or spikes are driven in the end grain, with the nail or spike axis parallel to the wood fibers, nominal lateral design values shall be multiplied by the end grain factor,  $C_{eg} = 0.67$ .

**2340.3.6 Diaphragm factor,  $C_{di}$ .** When nails or spikes are used in a diaphragm construction, nominal lateral design values shall be multiplied by the diaphragm factor,  $C_{di} = 1.1$ .

**2340.3.7 Toenail factor,  $C_{tn}$ .** When toenailed connections are used, nominal lateral design values shall be multiplied by the toenail factor,  $C_{tn} = 0.83$ .

#### 2340.4 Placement of Nails and Spikes.

**2340.4.1 Edge distance, end distance and spacing.** Edge distances, end distances and spacings for nails and spikes shall be sufficient to prevent unusual splitting of the wood.

**2340.4.2 Multiple nails or spikes.** When a connection contains more than one nail or spike, the total allowable design value for the connection shall be as specified in Section 2335.4.2.

**SECTION 2341 — METAL PLATE CONNECTORS****2341.1 General.**

**2341.1.1 Scope.** The following provisions apply to metal connector plates with extended teeth or plugs which are embedded into wood for the purpose of transferring load. Metal plates which depend entirely on nails for load transfer may be designed under these provisions, or may be designed based on the nail provisions in Part VI and the metal requirements in Section 2335.4.3.

**2341.1.2 Quality of metal plate connectors.** Metal plate connectors shall be of galvanized sheet steel meeting the requirements of Grade A, or better, as specified in ASTM A 446-89 and shall have the following minimum mechanical properties:

Yield point . . . . .	33,000 psi (227 N/mm <sup>2</sup> )
Ultimate strength . . . . .	45,000 psi (310 N/mm <sup>2</sup> )
Elongation in 2 inches (51 mm) . . . . .	20%

**2341.1.3 Size of metal plate connectors.** Each metal plate connector shall be of sufficient size to transfer the required load without exceeding the allowable design value for the connector in wood, or the design requirements in tension or shear for the net section of the metal plate (see Section 2335.4.3).

**2341.2 Design values for metal plate connectors.**

**2341.2.1 Tests for design values.** Tests to determine design values for metal plate connectors shall be conducted in accordance with an approved test method. The design value for normal load duration shall be determined by dividing the test load at wood-to-wood slip of 0.03 inch (0.8 mm) by 1.6, or by dividing the ultimate test load by 3.0, using the smaller of the two values as the design value. Design values determined in accordance with these test procedures shall be multiplied by all applicable modification factors (see Table 23-III-A) to obtain allowable design values.

**2341.2.2 Different species of wood.** Design values determined for one species of wood may be used for other species having the same or lower specific gravity (see Table 23-III-FF).

**SECTION 2342 — MISCELLANEOUS FASTENERS****2342.1 Drift Bolts and Drift Pins.**

**2342.1.1 Withdrawal design values.** Drift bolt and drift pin connections loaded in withdrawal shall be designed in accordance with good engineering practice.

**2342.1.2 Lateral design values.** Allowable lateral design values for drift bolts or drift pins driven in the side grain of wood shall not exceed 75 percent of the allowable lateral design values for common bolts of the same diameter and length in main member (see Section 2336.2). Additional penetration of pin into members should be provided in lieu of the washer, head and nut on a common bolt.

**2342.2 Spike Grids.** Wood-to-wood connections involving spike grids for load transfer shall be designed in accordance with good engineering practice.

**SECTION 2343 — LIGHT METAL PLATE CONNECTED WOOD TRUSS DESIGN**

**2343.1 Scope.** This standard, based on Design Specification for Light Metal Plate Connected Wood Trusses, TPI-85 of the Truss Plate Institute, shall cover requirements for the manufacture of light metal plate connectors and the design and fabrication of metal plate connected wood trusses in accordance with Division I.

**2343.2 Materials.**

**2343.2.1 Lumber.** Species and grades of lumber shall be clearly defined for each member of the truss. Design stresses used shall conform to the working stresses published in Division I.

### 2343.2.2 Connector plates.

**2343.2.2.1 General.** Metal connector plates shall be fabricated from galvanized steel sheet conforming to the requirements established for A446, Grade A, in U.B.C. Standard 22-1 or any higher grade of steel.

**2343.2.2.2 Plate marking.** Whenever separately applied nails or fasteners are to be used with a plate, the plate shall be provided with some positive means to indicate the locations of the separate fasteners used.

**2343.2.2.3 Manufacturing tolerances.** All connector plates shall be manufactured with all holes, plugs, teeth or prongs uniformly spaced and properly formed.

**2343.2.2.4 Identification.** All plates shall be identified by the plate manufacturer's name.

**2343.3 Heel Joint Designs.** The effects of eccentric loading shall be considered in the design of heel joints. For roof trusses spaced not more than 24 inches (610 mm) on center and spanning not more than 35 feet (10 668 mm), heel joint connector plates may be designed with sufficient capacity to resist the direct axial stresses imposed on both top and bottom chord members by their respective nail, tooth or plug groups using the reduced allowable connector loads for eccentric loading as shown in Table 23-III-PP.

### 2343.4 Connector Plate Evaluation.

#### 2343.4.1 Lateral load evaluation.

**2343.4.1.1 General.** Basic normal load values for use in designing wood joints using metal connector plate, per tooth or nail, plug or square inch or other unit shall be determined in accordance with the test procedure described herein. This procedure is based on the proportional limit value at 0.015-inch (0.4 mm) slip, with a further limitation based on the factor of safety at ultimate load. Figure 23-III-23 details the limits for dimensions of the test specimens and alternate test arrangements. Critical slip of 0.015 (0.4 mm) inch is measured from connector plate to each active wood member.

**2343.4.1.2 Wood test specimens.** Test specimens shall be fabricated from clear wood specimens having a moisture content of not less than 11 percent or more than 19 percent. Specimens shall be commercially available grades of the species of wood intended to be used in the trusses to be fabricated using the connectors. A range of ring counts and specific gravities shall be used in the test specimens and these properties of the test specimens shall be recorded with other test data. Five specimens of each of three species shall be tested. Two of the three species may be from the same species group of Table 23-III-QQ. Test specimens shall be cut and matchmarked so that the connector interacts with wood of substantially equal characteristics on each side of the test joint. These five specimens shall be referred to as "uncycled" specimens.

**2343.4.1.3 Aging.** To simulate the effects of aging and cycling of moisture content, five additional specimens of each species, matching those described in Section 2343.4.1.2, shall be subject to an accelerated change in moisture content and shall be referred to as "cycled" specimens. The moisture-cycling procedure shall require that specimens be fabricated at not less than 17 percent moisture content. Specimens shall then be dried to 7 percent moisture content within five days and shall be tested at a moisture content of not less than 10 percent. Results shall be compared with those obtained from the "uncycled" specimens referred to in Section 2343.4.1.2 above.

**2343.4.1.4 Methods of test.** Each tensile specimen shall be tested to failure in a calibrated testing machine by an approved independent testing agency. Test specimen arrangement may be either two-dial or four-dial setup as shown in Figure 23-III-23. Certification of calibration of the testing machine shall be made available on request. The test shall be conducted to achieve maximum load in about 10 minutes, but reach maximum load in not less than five or more than 20 minutes. A rate of motion of the movable crosshead of 0.035 inch (0.9 mm) in one minute,  $\pm$  50 percent will usually

permit reaching maximum load in the prescribed time. Record the speed used. Readings shall be taken so as to obtain not less than three increments of load before the proportional limit slip of 0.030 inch (0.8 mm) (wood to wood) has been reached. Readings shall include total load applied and amount of slip indicated by each dial gage. Applications of load shall continue at the original rate of application until failure occurs. Type of failure shall be noted for each specimen.

**2343.4.1.5 Evaluation of test result.** The basic normal plate value per tooth, nail, plug or square inch shall be the least of the values determined as follows:

1. The uncycled proportional limit slip divided by 1.6;
2. The cycled proportional limit slip divided by 1.33;
3. The uncycled ultimate load at failure divided by 4.0; or
4. The cycled ultimate load at failure divided by 3.33.

#### **2343.4.2 Net section.**

**2343.4.2.1 General.** Five perforated truss plates of each plate width shall be selected randomly from production. In addition, five solid plates shall be taken from the stock steel coil utilized to make the perforated plates.

The width and thickness of each specimen shall be measured to the nearest 0.001 inch (0.03 mm) and recorded before testing.

**2343.4.2.2 Procedure.** Tension tests on the solid plates shall be made and the ultimate load shall be recorded for each specimen.

Tension tests of the perforated truss plate shall be made by adequately clamping a single truss plate in a testing machine and holding it in place by a system so that universal movement of the test specimen is allowed.

The ultimate load shall be recorded for each specimen.

**2343.4.2.3 Ultimate tensile strength.** The cross-sectional area shall be computed for each specimen and divided into the ultimate load for each specimen. This value will be the ultimate tensile stress in pounds per square inch (N/mm<sup>2</sup>).

The ultimate tensile stress shall be averaged for the perforated truss plates and for solid steel plates.

**2343.4.2.4 Efficiency ratio.** The efficiency ratios shall be computed by dividing the average solid plate tensile stress into the average perforated plate tensile stress.

This efficiency ratio, when multiplied by the basic design value of steel, times the total cross-sectional area of the plate, yields the maximum safe load that may be carried by the truss plate net section in tension.

#### **2343.5 Full-scale Load Tests.**

**2343.5.1 General.** Full-scale load tests may be required at the option of the building official to verify the deflection and ultimate load or both characteristics of wood trusses at crucial spans. Any new type of connector system shall be substantiated by full-scale load tests of at least three substantially different designs to establish performance characteristics. Load tests shall be furnished on the longest span or most critical of each distinct series, configuration or type of unit. All tests shall conform to the requirements set forth herein and all test trusses shall be truly representative of the production and design.

Whenever possible, load testing shall be conducted under cover. When this is not possible or feasible, adequate weather protection shall be furnished to prevent adverse effects of moisture on the wood trusses and to prevent variation of the load caused by the absorption of water by the loading units. Loading units shall be separated to prevent the possibility of arch action.

Trusses may be tested in pairs or singly; however, in either case a minimum of three units would be tested when done singly; three setups when done in pairs.

Trusses shall be fabricated at least one week prior to testing.

**2343.5.2 Testing in pairs.** The test units shall be supported on firm stable reactors. They shall be spaced at the spacing for which they were designed. Experience has shown that properly securing the trusses to the reactors is recommended for safety. Use of strapping or metal framing connectors is suggested to resist tipping of the units during the load application. The top chords shall be sheathed with 4- to 6-foot (1219 mm to 1829 mm) lengths of any of the generally accepted sheathing materials (boards, plywood, reconstituted panel products, etc.). In any case, each piece shall be separated at least  $\frac{1}{8}$  inch (3.2 mm). A recommended practice is to use cross-bracing between the trusses to stabilize the setup; however, the trusses shall not be braced by tying the setup to adjacent permanent supports or other supports which may affect the free deflection of the trusses.

Deflection readings shall be taken and recorded for each truss as required for the purpose of the tests. For laboratory and investigative testing, it may be necessary to record deflection at all panel points, at the center of the trusses and at the midpoint of each lower chord panel, and at other locations that may be specified. Deflection readings may be averaged between each pair of trusses at corresponding locations.

Deflection measurements may be taken by any one of several methods; however, experience has shown that more accuracy is obtained when the gauges are independent of the support reactions. This is best accomplished by line scale and mirror arrangement. The line is supported on free-rolling bearings and kept under tension by means of weights. When the tests are conducted where temperature conditions change, using a braided fish line is recommended. Under controlled laboratory conditions, piano wire or monofilament line will suffice. Deflector readings are taken by reading on the scale which is attached to the truss adjacent to the line. Adjusting the eye position so that the line covers its image in the mirror removes parallax from the scale reading. Scale readings may then be referenced to either the top or bottom edge of the line. Dial gauges may be used to measure deflection; however, a precise measurement must be taken of settlement at the supports.

The other deflection readings are then subject to correction for settlement.

**2343.5.3 Testing singly.** The trusses (a minimum of three trusses) may be tested as single units in either a vertical or horizontal position in a properly designed test facility. The loads may be applied uniformly or at concentrated points along the chords. Wood strips may be attached along the top chords, or frictionless brackets or attachments may be used to prevent the load brackets from slipping down the top chords on steep-sloped trusses.

Deflection measurements shall be similar to the procedures described in Section 2343.5.2.

**2343.5.4 Load-deflection test procedures.** Apply one-half design load and hold for five minutes. This application allows the truss to be settled and provides an opportunity for checking alignment, equipment positioning and overall setup. This initial preliminary load shall be removed and deflection readings taken within five to 10 minutes. The design dead load is then applied, and after a minimum hold period of five minutes, the deflection readings are taken. Optionally, this dead load may be left in place 24 to 48 hours to establish a basic dead load position.

With the dead load applied, increase the load to one-fourth, one-half, three-fourths and full design live load. Apply the incremental loads at a uniform rate of loading with a minimum of five minutes hold at each increment. In any event, a minimum of 15 minutes is required to reach design live load.

Continue to load the truss incrementally in quarter live load units to dead load plus 2.0 times the design live load. The truss shall sustain this loading for at least 30 minutes without exceeding a deflection of  $L_s/180$  or  $L_s/120$ , respectively, for plaster and drywall ceilings.

Remove all live load and, within 30 minutes, the truss must recover to a position of  $L_s/360$  or  $L_s/240$ , respectively, relative to basic dead load. If deflections due to the loads of preceding para-

graph remain within  $L_s/360$  or  $L_s/240$ , respectively, the loading may be increased per Section 2343.5.5 without removing the live load.

**NOTE:** With single truss test using hydraulic cylinders, the dead load may be partially removed so the cylinders retract properly. Then immediately return to basic dead load.

**2343.5.5 Load to failure test.** Load to failure tests as herein described may be desired after the above load deflection test has been completed.

If Section 2343.5.4 has been satisfied, continue loading in one-fourth load increments at five-minute intervals or longer at manufacturer's option, until failure occurs. At basic dead load plus 3.0 times design total load, the truss shall sustain the load for five minutes.

**2343.5.6 Reporting test results.** The written report shall include method and location of testing and personnel performing tests. The report shall include the lumber grades, lumber moisture content at time of tests, plate type and size at each location. A detailed drawing of the truss, pictures of the setup and failure location, if it occurred, is required.

**2343.6 Marking.** Each truss shall be legibly branded, marked or otherwise have permanently affixed thereto the following information located within 2 feet (610 mm) of the center of the span on the face of the bottom chord:

1. Identity of the company manufacturing the truss.
2. The design load.
3. The spacing of trusses.

#### **2343.7 Fabrication Quality.**

**2343.7.1 General.** This section shall be used in conjunction with an in-plant quality assurance procedure and an engineered truss design. Truss manufacturers and inspection agencies shall establish filing methods which document the proper application of quality assurance procedures throughout the manufacturing and inspection process.

**2343.7.2 Engineering.** Truss engineering is an essential part of the quality assurance procedure. Truss engineering and a certificate of compliance as per Section 1701.7, shall be provided for every structural truss setup manufactured.

Truss engineering design shall include reference to the design criteria used, lumber requirements, plating requirements, design loading, adjustments to metal connector plate and lumber design values and truss engineer's registered seal.

#### **2343.7.3 Lumber.**

**2343.7.3.1 Grade, size and species.** Truss lumber shall be the grade, size species specified by the design engineer. Truss lumber of a higher stress grade of the same size and species combination may be substituted for the stress grade, size and species combination specified by the design engineer. Manufactured lumber may be approved within the appropriate jurisdiction. Changes in size and/or species or conversion to manufactured lumber shall require additional analysis by the design engineer to provide equivalency. Grademarks and/or other identification shall be preserved as much as possible during the manufacturing process for verification in the complete truss unit.

**2343.7.3.2 Moisture content.** All lumber, including pressure-treated lumber, used in the manufacture of wood trusses shall have a moisture content (MC) of less than or equal to 19 percent at time of fabrication, unless engineering design specifically states that the moisture content may be higher. If green lumber (over 19 percent MC) is used, the engineering design shall clearly show that lumber values were reduced for higher moisture content. Basic plate design values shall be reduced 20 percent when the plates are to be installed in lumber having a moisture content greater 19 percent at time of fabrication. Pressure-preservative-treated lumber shall bear the quality mark of an approved inspection agency which maintains continued supervision, testing and inspection over the

treating and redrying of the lumber product. The quality mark shall indicate the material has been treated and redried to 19 percent MC or less.

**2343.7.3.3 Characteristics.** Lumber shall not have characteristics which would interfere with the proper placement of metal connector plates, or the fabrication of uniformly consistent trusses.

**2343.7.3.4 Fire retardants.** Lumber pressure impregnated with fire-retardant chemicals shall be identified by the quality mark of a code-approved inspection agency which maintains continued supervision, testing and inspection over the quality of the treatment and drying process and design value adjustments. The quality mark shall indicate the material has been treated and redried to 19 percent MC or less, and in conformance to those procedures established by the manufacturer which were used in the evaluation and qualification of that treatment. The quality shall indicate that the design value adjustments are in accordance with U.B.C. Standard 23-6.

**2343.7.4 Special markings.**

**2343.7.4.1 Installation.** Bottom chord bearing parallel chord trusses shall be clearly marked in a manner which will avoid inverted installation and shall permit visual verification of proper orientation after installation.

**2343.7.4.2 Bearing locations.** Trusses having bearing locations other than at the end of heel locations shall have bearing points clearly marked in a manner which permits verification during and after installation.

**2343.7.4.3 Lateral bracing.** All truss chord and web members which require special lateral bracing to prevent lateral buckling (such as, but not limited to, top chords of piggy-back trusses, long compression webs and bottom chords at cantilevers) due to engineering analysis shall be clearly marked to call attention to the need for such field bracing during and after installation.

**2343.7.4.4 Alternatives.** In lieu of marking trusses, it shall be acceptable to document the location of special bearing conditions, permanent bracing and orientation of trusses by means of engineering drawings, erection plans and/or special details.

**2343.7.5 Plating.**

**2343.7.5.1 Tests.** Metal connector plates used in the manufacture of wood trusses shall be manufactured and evaluated in accordance with Section 2343.4. Metal connector plates used in the manufacture of wood trusses shall be of the gauge, type and minimum size specified by the truss design engineer. Substituting larger metal connector plates is acceptable per the provisions of Sections 2343.7.5.7 and 2343.7.8.

**2343.7.5.2 Positioning.** The metal connector plate sizes shall be determined by engineering analysis; metal connector plates shall be placed on both faces of the truss at each joint and positioned in accordance with the engineered design dimensions. The positioning shall be defined in either of two ways:

1. Symmetrical positioning (as shown in Figure 23-III-24).
2. Nonsymmetrical positioning (as shown in Figure 23-III-25).

**2343.7.5.3 Effective metal connector plate contact area.** The engineer-specified metal connector plate positioning and metal connector plate contact area is developed with the provision that 10 percent of the specified metal connector plate contact area is ineffective due to metal connector plate misplacement, partial embedment, tooth flattening, gaps between joined members and on-grade lumber characteristics (knots, wane, pitch pockets and holes).

**2343.7.5.4 The 10 percent rule.** The 10 percent area rule is derived from a manufacturing adjustment factor used in the establishment of basic allowable design properties for metal connector plate teeth stressed in lateral withdrawal. The derivation of allowable metal connector plate properties is referenced in Section 2343.4.

**2343.7.5.5 Combinations.** To assess a plated connection for sufficient (90 percent or better) clear wood-plate contact area, the following manufacturing characteristics (knots, wane, pitch pockets, holes, gaps and metal connector plate misplacement) can be found in combination in the metal connector plate contact area. These characteristics shall not reduce the engineer-specified metal connector plate contact area by more than 10 percent.

**2343.7.5.6 Tolerances.** The allowable tolerance for metal connector plate positioning shall be as shown in Figure 23-III-26. The tolerance shall apply to the nearside metal connector plate, provided the far-side metal connector plate is positioned without variance. Tolerances shall be halved if the near- and far-side metal connector plates are equally mislocated. The metal connector plate location tolerance shown in Figure 23-III-26 is a field air calibrated to the 10 percent area rule and shall apply to the metal connector plate misplacement characteristic only. Joints that exhibit knots, wane, pitch pockets, holes and gaps in addition to metal connector plate misplacement shall not use Figure 23-III-26. The 10 percent rule for these characteristics in combination shall apply. Increased metal connector plate sizes may be used to increase placement tolerances, provided Sections 2343.7.5.7 and 2343.7.8 is followed.

**2343.7.5.7 Overplating.** A metal connector plate with larger dimensions in one or both directions and of the same type and gauge may be substituted for the specified size, provided its placement does not interfere with other design aspects or the function of the truss as shown in Figure 23-III-27.

**2343.7.5.8 Storage and handling.** Metal connector plates shall be protected from damage during storage and shall be in an undamaged condition when they are used. Trusses shall be adequately plated to prevent damage during manufacturing and delivery.

**2343.7.5.9 Tooth flattening.** Metal connector plates showing visible evidence of flattening of more than 5 percent of the teeth for each connected member shall not be acceptable unless approved by the design engineer. Flattening is defined as one fourth of tooth length or greater than is visible within the tooth opening as shown in Figure 23-III-28. The 5 percent evidence of flattening is a maximum tolerance as it pertains to the 10 percent rule; it shall not be used in combination with any other manufacturing characteristics (see Section 2343.7.8).

#### **2343.7.6 Assembly.**

**2343.7.6.1 Accuracy.** Trusses shall have wood members that are accurately cut, so that assembly into the design configuration will result in wood-to-wood bearing between truss wood members at the interface, and uniformity between completed, similarly designed truss units. The location of chords, webs and joints shall be as specified in the engineered design.

**2343.7.6.2 Splices.** More than one splice in a panel is not permitted.

**2343.7.6.3 Cutting.** Members shall be cut in accordance with the design specifications.

**2343.7.6.4 Tolerances.** Truss manufacturing tolerances resulting from engineering design specifications shall not exceed the variance shown in Table 23-III-RR.

**2343.7.6.5 Gaps.** Trusses shall have close-fitting wood members at every joint. Gaps in joints resulting from inaccuracies in cutting and assembly shall be limited to no more than two joints or 20 percent of the total number of joints, whichever is greater.

**2343.7.6.6 Repair.** Correction of gaps exceeding the tolerances in Section 2343.7.6.4 are shown in Section 2343.7.8.

**2343.7.6.7 Camber.** Truss camber shall be provided as specified in the engineered design.

**2343.7.6.8 Plating over lumber characteristics.** Plating over off-grade knots or other lumber characteristics between panel points and other joints (splices) to strengthen or reinforce the wood member is not permitted unless so specified by the truss engineer. Such plating requirements shall conform to Sections 2343.7.6.9 and 2343.7.8.

**2343.7.6.9 The 10 percent rule.** On-grade lumber characteristics, such as knots, wane, pitch pockets, holes and gaps, in the metal connector plate area shall be permitted provided such characteristics do not affect more than 10 percent of the minimum engineer-required metal connector plate area or required number of effective teeth in the affected member. Required area of effective teeth calculations are shown in Figure 23-III-32.

**2343.7.6.10 Embedment.** All trusses shall have fully embedded metal connector plates at every joint. The bottom surface of the metal connector plates shall be in firm contact with the wood surfaces. The embedment tolerance shall not exceed a gap of no greater than 10 percent of the tooth length, or  $1/16$  inch (1.6 mm), whichever is greater, for no more than one third of the minimum required metal connector plate contact area, for each member as shown in Figures 23-III-33 and 23-III-34. However, no less than two thirds of the minimum required metal connector plate contact area for each member shall be in firm contact with the wood. Tooth length is measured from the tip of the tooth to the nearest face of the metal connector plate from which it is formed. If a metal connector plate has more than one length of teeth, the shortest tooth length shall be used. The metal connector plate embedment tolerance as shown in Figures 23-III-33 and 23-III-34 is a maximum tolerance as it pertains to the 10 percent rule; it shall not be used in combination with any other manufacturing characteristics.

**2343.7.6.11 Rejection.** More than one maximum allowable tolerance in any given joint shall be cause for rejection of that joint.

**2343.7.6.12 Splitting.** Excessive splitting in any wood member by the metal connector plate teeth shall not be acceptable. Splits resulting from the manufacturing process shall not exceed those permitted for the grade and species of lumber used.

**2343.7.6.13 Documentation.** Fabrication inaccuracies exceeding the allowable tolerances are acceptable per the provisions of Sections 2343.7.8, 2343.7.9 and 2343.7.10, and/or upon approval and follow-up documentation by a registered engineer. Any necessary repair authorization shall be documented by a registered engineer subject to the approval of the building official.

#### **2343.7.7 Handling.**

**2343.7.7.1 Structural integrity.** Trusses shall not be subjected to any external force effect during manufacturing, packaging, storage and delivery which may impair their structural integrity.

**2343.7.7.2 Fire-retardant-treated lumber.** Fire-retardant-treated (FRT) lumber shall not be subjected to impact load which may impair the structural integrity of the trusses manufactured from FRT lumber.

#### **2343.7.8 Overplating.**

**2343.7.8.1 Prior to plating.** Embedment areas prior to plating that exhibit any combination of knots, wane, pitch pockets, holes and gaps shall be evaluated to determine if the engineer-specified metal connector plate size per member has 90 percent or better of clear wood contact area. A metal connector plate with larger dimensions as shown in Figures 23-III-27 and 23-III-35 in one or both directions and of the same type and gage may be substituted for the specified size to achieve 90 percent or better of the specified clear wood-plate contact area. This check applies to all joints; however, certain joints exhibiting gaps as defined in Section 2343.7.9 shall require shimming in addition.

**2343.7.8.2 Embedded metal connector plates.** Embedded metal connector plates that exhibit any combination of knots, wane, pitch pockets, holes, gaps and misplacement shall be evaluated to determine if the clear wood-plate contact area has 90 percent or better of the engineer-specified clear wood-plate contact area. Embedded metal connector plates not exhibiting 90 percent or better of the engineer-specified clear wood-plate contact area shall be removed and overplated in accordance with Section 2343.7.8. This check applies to all joints; however, certain joints exhibiting gaps as defined in Section 2343.7.9 shall require shimming in addition.

**2343.7.8.3 Tooth flattening.** Metal connector plates exhibiting flattened teeth in excess of the 5 percent minimum required teeth (i.e., metal connector plate contact area) per member shall be removed. A larger metal connector plate meeting the provisions of Sections 2343.7.5.7 and 2343.7.8.1 shall be affixed provided the larger metal connector plate exhibits firm embedment and no flattened teeth.

**2343.7.9 Shimming.** The use of galvanized metal shims, as shown in Figure 23-III-36, or alternatives acceptable to a registered engineer to obtain firm bearing between members at open compression joints (spices, peaks and web-chord interfaces) is acceptable provided the number of open joints so treated does not exceed two per truss or 20 percent of the total number of joints, whichever is greater, and the gaps prior to shimming do not exceed the tolerances in Section 2343.7.6.4. Metal shims shall be long enough to bend over at least 1 inch (25 mm) along the member being shimmed. The shim shall be fixed in position with a 6d deformed shank nail to prevent accidental loss or removal (see Figure 23-III-36) and shall be documented by a professional engineer.

**2343.7.10 Repressing.** Embedded metal connector plates exceeding the tolerances in Section 2343.7.6.10 shall be repressed. Other manufacturing characteristics are acceptable in the metal connector plate contact area per Sections 2343.7.8 and 2343.7.9 provided the repressed metal connector plate exhibits firm embedment and no flattened teeth.

**2343.8 In-plant Inspection.** Each truss manufacturer shall retain an approved agency having no financial interest in the plant being inspected to make nonscheduled inspections of truss fabrication and delivery operations. The inspections shall cover all phases of the truss operation including: lumber storage, handling, cutting, fixtures, presses or rollers, fabrication bundling and banding, handling and delivery.

#### **2343.9 Parallel Chord Truss Design.**

**2343.9.1 General.** The design standard shall be applicable to parallel chord wood trusses that have the major cross section of 2-inch by 4-inch (51 mm by 102 mm) lumber members oriented horizontally.

#### **2343.9.2 Notations and symbols.**

##### **WHERE:**

$A$  = cross-sectional area of member.

$b$  = width of member.

$D$  = overall depth of truss.

$DL$  = dead load.

$d$  = critical thickness or width of members in buckling.

$d'$  = distance between centroids of chords.

$E$  = modulus of elasticity.

$F_b$  = design value for extreme fiber in bending.

$F_c$  = design value for compression parallel to grain.

$F_c$  = design value for compression parallel to grain adjusted for  $L'/d$ .

$F_t$  = design value for tension parallel to grain.

$G$  = concentrated load.

$h$  = thickness of member.

$I_c$  = moment of inertia of chord.

$I_e$  = equivalent moment of inertia of the truss.

$J$  = unitless factor used in the interaction equation for combined bending and axial compression.

- $K$  = largest slenderness ratio ( $L/d$ ) at which the intermediate column formula applies for determining design value in compression parallel to grain.
- $K_b$  = load and span effect constant.
- $L$  = nominal panel length of chords used in computing bending moment.
- $L_c$  = length of cantilever.
- $L_o$  = width of the rectangular opening measured from center of vertical web to center of vertical web.
- $L_p$  = center-to-center spacing of purlins.
- $L_s$  = clear span length measured from face-to-face of supports.
- $L_w$  = buckling length of web member.
- $L'$  = effective buckling length.
- $LL$  = live load.
- $M$  = bending moment.
- $M_e$  = moment of an equivalent beam at the location under investigation.
- $M_o$  = moments produced at a rectangular opening due to shear.
- $M_p$  = moment due to loads acting on chord between panel points; panel moments may be at midpanel or panel points.
- $M_s$  = secondary moment.
- $P$  = axial load.
- $S$  = section modulus.
- $V_e$  = shear of the equivalent beam.
- $w$  = uniformly distributed load.
- $WL$  = wind load.
- $X$  = offset of center line of rectangular opening from center line of truss.
- $\Delta$  = deflection of truss.

**2343.9.3 Truss loading.** Uniformly distributed loads on top and bottom chords shall be considered as equivalent concentrated loads applied at panel points for determination of axial forces.

Trusses having concentrated loads shall be designed specifically to carry these loads in addition to any other loading which may be applied to the truss within the allowable stresses defined in this standard.

A nonbearing partition may be neglected in design, provided:

1. Trusses are not over 24 inches (610 mm) on centers.
2. Top chord panel length of supporting truss system does not exceed 30 inches (762 mm).
3. Design live load of supporting truss system results from a residential occupancy and is not less than 40 psf (1.92 kN/m<sup>2</sup>).
4. Partition weight does not exceed 60 pounds per lineal foot (876 N/m).
5. When partitions parallel to supporting trusses are not located on or immediately adjacent to a truss, the subfloor shall be adequate for the partition load.

Trusses are to be designed for the most critical combination of gravity dead load, live load and/or wind load.

**2343.9.4 Axial forces.** For the purpose of determining the axial forces in a truss, all members may be assumed to have pinned joints. Forces are assumed to act along the centroids of the chord members. The effective depth  $d'$  of the truss is the distance between the centroids of the chords.

The vertical component of the minimum design force in any diagonal web shall not be less than one sixth of the simple span total load.

The minimum design force for any member shall not be less than 375 pounds (1668 N).

**2343.9.5 Bending moments in chords.** For the purpose of determining the bending moments in the chords, the chord members shall be modeled as continuous beams with the web members pin connected to the chords.

Any accurate engineering method may be used, provided the method accounts for:

1. The bending moments due to the loads acting on the chords between panel points (joints); henceforth called the panel moments.
2. The bending moments induced into the chords by the overall deformation of the truss; henceforth called the secondary moments.
3. The bending moments produced at a rectangular opening due to the transfer of vertical load (shear) across the opening, henceforth called the open-panel moments.

The simplified method refers to an equivalent beam. The moments and shears referred to are those of a beam with the same span, points of support and loading conditions as the truss under investigation. The sign convention used is one that gives the following results to a uniformly, downward-loaded simple-span beam:

1. Positive moment throughout.
2. Positive shear on the left half of the beam and negative shear on the right half of the beam. See Figure 23-III-44.

The simplified method applies only to trusses that meet the following conditions:

1. All concentrated loads shall be located at joints.
2. The uniform load  $w$  shall not differ by more than 20 percent (of the larger loading) in adjacent panels.
3. Rectangular openings shall not exceed 24 inches (610 mm) clear width.
4. All rectangular openings shall be located within 15 inches (381 mm) of midspan or within 15 inches (381 mm) of the location of zero shear on an equivalent beam. The offset shall be measured from the center of the rectangular opening.
5. No more than one rectangular opening shall be present in each span.
6. If a rectangular opening is present and this opening is offset greater than 4 inches (102 mm) from the location of zero shear on an equivalent beam, then the moment of inertia of the top chord at the rectangular opening shall be equal to that of the bottom chord at the opening.

The panel moment  $M_p$  shall be determined at the joints (panel point moment) and between the joints (midpanel moment). The moments determined shall be based on the uniform load acting downward. If the uniform load acts upward, the signs of the moments given shall be reversed.

The panel point moments shall be taken as follows:

$$M_p = \text{zero for end joints.}$$

$$M_p = -w L^2/9 \text{ for joints located at one panel from the end of the chord.}$$

$$M_p = -w L^2/12 \text{ for all other interior joints.}$$

Where  $L$  is the largest of the following:

1. The average length of the two panels adjacent to the joint under investigation.
2. Ninety percent of the longer of the two panels adjacent to the joint under investigation.

The midpanel moments shall be taken as:

$$M_p = + wL^2/13 \text{ for end panels.}$$

$$M_p = + wL^2/24 \text{ for interior panels.}$$

where  $L$  is the length of the panel under investigation.

The secondary moments shall be taken as:

$$M_s = \frac{I_c}{I_e} \times M_e$$

**WHERE:**

1.  $I_c$  is the moment of inertia of the chord member under investigation.
2.  $I_e$  is the equivalent moment of inertia of the truss at the location under investigation.
3.  $M_e$  is the moment of an equivalent beam at the location under investigation.

The sign of the secondary moment shall be the same as that of the equivalent beam.

The open-panel moments shall be considered to act at all joints adjacent to the rectangular opening only. The open-panel moment shall have a magnitude of:

$$M_o = \frac{V_e \times L_o}{4}$$

**WHERE:**

1.  $V_e$  is the shear of the equivalent beam at the same location as the center of the rectangular opening.
2.  $L_o$  is the width of the rectangular opening measured from center of vertical web to center of vertical web.

When the shear on the equivalent beam  $V_e$  is positive, the moment  $M_o$  at the joints to the left of the open panel shall be taken as negative and the moment  $M_o$  at joints to the right of the open panel shall be taken as positive. When the shear on the equivalent beam  $V_e$  is negative, the above convention shall be reversed.

The total moment at a given panel point is the absolute value of the sum of the panel-point moment, the secondary moment and the open-panel moment.

$$M = M_p + M_s + M_o$$

The total moment at a given midpanel is the absolute value of the sum of the midpanel moment and the secondary moment.

$$M = M_p + M_s$$

The moment used in Section 2343.9.6 for a given panel shall be the larger of:

1. The total moment at the panel point at the left of the panel.
2. The total moment at the midpanel.
3. The total moment at the panel point at the right of the panel.

**2343.9.6 Member design.** All members subject to axial tension shall be so proportioned that:

$$\frac{P}{A} \leq F_t$$

All members subject to axial compression shall be so proportioned that:

$$\frac{P}{A} \leq F'_c$$

and  $F'_c$  is calculated as shown in Table 23-III-SS.

All members subject to bending only shall be so proportioned that:

$$\frac{M}{S} \leq F_b$$

All members subject to both bending and axial tension shall be so proportioned that:

$$\frac{P/A}{F'_c} + \frac{M/S}{F_b \cdot J(P/A)} \leq 1.00$$

Where  $F'_c$  is defined in Table 23-III-SS, and

$$J = \frac{(L'/d) - 11}{K - 11}$$

except that  $J$  shall not be less than zero or greater than one.

Lumber design values may be adjusted for duration of load in accordance with Section 2304.3.

The  $L'/d$  for compression members shall not exceed 50, and  $L'/d$  for tension members, including tension members subject to reversal of stress, shall not exceed 80. For chords and webs the effective buckling length shall be as shown in Table 23-III-TT. See Figure 23-III-45.

Where three or more trusses are positioned side by side and spaced no farther than 24 inches (610 mm) apart and are joined by properly attached roof sheathing or flooring and/or strongbacks or other effective load-distributing elements which are properly attached to the trusses, the allowable stress in bending may be increased 15 percent.

In accordance with Tables 23-I-A-1, 23-I-A-2, 23-I-A-4 and 23-I-A-5 criteria, an additional 10 percent increase in allowable bending stress is permitted for 2-inch by 4-inch (51 mm by 102 mm) lumber used flatwise. This stress increase is not dependent upon being part of a repetitive member system.

**2343.9.7 Joint design.** Connector plates shall be designed for installation on both faces of each joint with sufficient plate area or wood-to-wood contact in compression or bearing to resist the critical forces or minimum forces described in Section 2343.9.4.

Connector plates shall have the minimum properties as set forth in Section 2343.4.

When the net plate area method is used to determine the connector plate design rating, all plates shall be designed using a 1/2-inch (13 mm) end distance measured parallel to the member and a 1/4-inch (6.4 mm) edge distance measured perpendicular to the member.

When the gross area method is used to determine the connector plate design rating, 85 percent of the wide face test values shall be used for plating on 1.5-inch (38 mm) surfaces.

Plate basic design values (lateral resistance) established in accordance with Section 2343.4 shall be reduced 20 percent when the plates are to be installed in lumber having a moisture content greater than 19 percent at the time of fabrication.

The basic design values of plated (lateral resistance) may be adjusted for various durations of load in accordance with Section 2304.3.4.

The net section of plates for all tension joints shall be designed using the basic tensile design value of the metal adjusted for the plate efficiency factor. Plate tensile design values may be increased by 33.3 percent for wind or earthquake loads, but in no case shall the tensile design values be exceeded for dead load and other live loads.

The net shear section of plates for all joints involving shear shall be designed using the plate shear design value adjusted for the plate shear efficiency factor. Plate shear design values may be increased by 33.3 percent for wind or earthquake loads, but in no case shall the shear design values be exceeded for dead load and other live loads.

**2343.9.8 Bearings.** Either top chord or bottom chord-bearing trusses are acceptable.

Bearing area shall be sized to develop the full design reactions in accordance with the design value in compression perpendicular to grain.

Truss bearing (either top or bottom chord bearing) must extend a distance of not less than 3 inches (76 mm) over the support. Engineered anchorage may be substituted for the 3-inch (76 mm) minimum support.

For top chord supported trusses, the clearance between the outside edge of the first connector plate and the inside edge of the bearing shall not exceed the following:

1. For single 4-inch by 2-inch (102 mm by 51 mm) top chord, 1/2 inch (13 mm) maximum.
2. For double 4-inch by 2-inch (102 mm by 51 mm) top chord, 1 inch (25 mm) maximum.

**2343.9.9 Bridging.** Continuous cross and/or horizontal bridging between trusses shall be provided at spacings of approximately 10 feet (3048 mm) for floors and 16 feet (4877 mm) for roofs. Cross bridging shall be minimum 1 by 3s (25 by 76 mm) with two 8d nails each end. Horizontal bridging shall be minimum 2-inch by 6-inch (51 mm by 152 mm) strongbacks (on edge) attached to each truss with three 10d nails.

Strongbacks shall be attached to walls at their outer ends or restrained by other means.

**2343.9.10 Deflection.** Deflection calculations shall be based on full live load and may be determined using beam formulas. If two grades of chord lumber having different  $E$  values are used, deflection calculations may be based on the average  $E$  value. Other accepted methods of calculating deflections may be used, provided adjustments for web shear and joint slippage are considered.

For uniformly loaded, simply supported, parallel chord trusses, deflection may be calculated as follows:

$$\Delta = \left( \frac{1.33 K_b}{EI_e} \right) (1 + 0.015X)$$

$$K_b = \frac{5 w L_s^4}{384}$$

For SI: 
$$\Delta = \left( \frac{1.33 K_b}{EI_e} \right) \left( \frac{25.4 + 0.015X}{25.4} \right)$$

**WHERE:**

- $\Delta$  = deflection at center line of truss in inches (mm).
- $w$  = uniformly load in pounds per lineal inch (N/mm).
- $L_s$  = clear span in inches (mm).
- $I_e$  = moment of inertia of the cross-sectional areas of the top and bottom chords about the N.A. of the truss. See Figure 23-III-46.
- $E$  = average modulus of elasticity of chord lumber [psi (N/mm<sup>2</sup>)].
- $K_b$  = load and span effect constant.
- $X$  = offset of centerline of opening from centerline of truss in inches (mm). See Figure 23-III-47. [Not to exceed 15 inches (381 mm) for this deflection formula.]

Maximum live load deflection for floor trusses shall be limited to  $L_s/360$ .

The portion of the total truss deflection due to live load shall not exceed  $L_s/360$  when plaster is used or  $L_s/240$  when flexible-type ceiling such as drywall or a suspended ceiling is used. The deflection of roof trusses without a finished ceiling shall not exceed  $L_s/180$ .

**2343.9.11 Camber.** The minimum recommended camber between supports shall equal the dead load deflection.

TABLE 23-III-A—APPLICABILITY OF ADJUSTMENT FACTORS FOR CONNECTIONS

		LOAD DURATION FACTOR <sup>1</sup>	WET SERVICE FACTOR <sup>2</sup>	TEMPERATURE FACTOR	GROUP ACTION FACTOR	GEOMETRY FACTOR <sup>3</sup>	PENETRATION DEPTH FACTOR <sup>3</sup>	END GRAIN FACTOR <sup>3</sup>	METAL SIDE PLATE FACTOR <sup>3</sup>	DIAPHRAGM FACTOR <sup>3</sup>	TOENAIL FACTOR <sup>3</sup>
Bolts	$Z' = (Z)$	$(C_D)$	$(C_M)$	$(C_t)$	$(C_g)$	$(C_\Delta)$	•	•	•	•	•
Lag screws	$W' = (W)$ $Z' = (Z)$	$(C_D)$ $(C_D)$	$(C_M)$ $(C_M)$	$(C_t)$ $(C_t)$	• $(C_g)$	• $(C_\Delta)$	• $(C_d)$	$(C_{eg})$ $(C_{eg})$	• •	• •	• •
Split ring and shear plate connectors	$P' = (P)$ $Q' = (Q)$	$(C_D)$ $(C_D)$	$(C_M)$ $(C_M)$	$(C_t)$ $(C_t)$	$(C_g)$ $(C_g)$	$(C_\Delta)$ $(C_\Delta)$	$(C_d)$ $(C_d)$	• •	$(C_{st})$ •	• •	• •
Wood screws	$W' = (W)$ $Z' = (Z)$	$(C_D)$ $(C_D)$	$(C_M)$ $(C_M)$	$(C_t)$ $(C_t)$	• •	• •	• $(C_d)$	• $(C_{eg})$	• •	• •	• •
Nails and spikes	$W' = (W)$ $Z' = (Z)$	$(C_D)$ $(C_D)$	$(C_M)$ $(C_M)$	$(C_t)$ $(C_t)$	• •	• •	• $(C_d)$	• $(C_{eg})$	• •	• $(C_{di})$	$(C_m)$ $(C_m)$
Metal plate connectors	$Z' = (Z)$	$(C_D)$	$(C_M)$	$(C_t)$	•	•	•	•	•	•	•
Drift bolts and drift pins	$W' = (W)$ $Z' = (Z)$	$(C_D)$ $(C_D)$	$(C_M)$ $(C_M)$	$(C_t)$ $(C_t)$	• $(C_g)$	• $(C_\Delta)$	• $(C_d)$	$(C_{eg})$ $(C_{eg})$	• •	• •	• •
Spike grids	$Z' = (Z)$	$(C_D)$	$(C_M)$	$(C_t)$	•	$(C_\Delta)$	•	•	•	•	•

<sup>1</sup>The load duration factor,  $C_D$ , shall not exceed 1.6 for connections [Section 2335.5.2].

<sup>2</sup>The wet service factor,  $C_M$ , shall not apply to toenails loaded in withdrawal [Section 2340.2.3].

<sup>3</sup>Specific information concerning geometry ( $C_\Delta$ ), penetration depth factors ( $C_d$ ), end grain factors ( $C_{eg}$ ), metal side plate factors ( $C_{st}$ ), diaphragm factors ( $C_{di}$ ) and toenail factors ( $C_m$ ) is provided in Parts II through VIII of this standard.

TABLE 23-III-B—WET SERVICE FACTORS,  $C_M$ , FOR CONNECTIONS

FASTENER TYPE	CONDITION OF WOOD <sup>1</sup>		WET SERVICE FACTOR $C_M$
	At Time of Fabrication	In Service	
Split ring or shear plate <sup>2</sup> connectors	Dry	Dry	1.0
	Partially seasoned	Dry	see Footnote 3
	Wet	Dry	0.8
	Dry or wet	Partially seasoned or wet	0.67
Bolts or lag screws	Dry	Dry	1.0
	Partially seasoned or wet	Dry	see Footnote 4
	Dry or wet	Exposed to weather	0.75
	Dry or wet	Wet	0.67
Laterally loaded drift bolts or drift pins	Dry or wet	Dry	1.0
	Dry or wet	Partially seasoned or wet or subject to wetting and drying	0.7
Wood screws	Dry or wet	Dry	1.0
	Dry or wet	Exposed to weather	0.75
	Dry or wet	Wet	0.67
Common wire nails, box nails or common wire spikes			
—Withdrawal loads	Dry	Dry	1.0
	Partially seasoned or wet	Wet	1.0
	Partially seasoned or wet	Dry	0.25
	Dry	Subject to wetting and drying	0.25
—Lateral loads	Dry	Dry	1.0
	Partially seasoned or wet	Dry or wet	0.75
	Dry	Partially seasoned or wet	0.75
Threaded hardened steel nails	Dry or wet	Dry or wet	1.0
Metal connector plates	Dry	Dry	1.0
	Partially seasoned or wet	Dry or wet	0.8

<sup>1</sup>Conditions of wood are defined as follows for determining wet service factors for connections:

Dry wood has a moisture content  $\leq 19$  percent.

Wet wood has a moisture content  $\geq 30$  percent (approximate fiber saturation point).

Partially seasoned wood has 19 percent < moisture content < 30 percent.

“Exposed to weather” means that the wood will vary in moisture content from dry to partially seasoned, but is not expected to reach the fiber saturation point at times when the connection is supporting full design load.

“Subject to wetting and drying” means that the wood will vary in moisture content from dry to partially seasoned or wet, or vice versa, with consequent effects on the tightness of the connection.

<sup>2</sup>For split ring or shear plate connectors, moisture content limitations apply to a depth of  $\frac{3}{4}$  inch (19 mm) below the surface of the wood.

## FOOTNOTES TO TABLE 23-III-B—(Continued)

<sup>3</sup>When split ring or shear plate connectors are installed in wood that is partially seasoned at the time of fabrication, but that will be dry before full design load is applied, proportional intermediate wet service factors shall be permitted to be used.

<sup>4</sup>When bolts or lag screws are installed in wood that is wet at the time of fabrication, but that will be dry before full design load is applied, the following wet service factors,  $C_M$ , shall apply:

Arrangement of bolts or lag screws	$C_M$
One fastener only, or Two or more fasteners placed in a single row parallel to grain, or Fasteners placed in two or more rows parallel to grain with separate splice plates for each row	1.0
All other arrangements	0.4

When bolts or lag screws are installed in wood that is partially seasoned at the time of fabrication, but that will be dry before full design load is applied, proportional intermediate wet service factors shall be permitted to be used.

**TABLE 23-III-C—GROUP ACTION FACTORS,  $C_g$ , FOR BOLT OR LAG SCREW CONNECTIONS WITH WOOD SIDE MEMBERS<sup>2</sup> FOR  $D = 1$  INCH (25 mm),  $s = 4$  INCHES (102 mm),  $E = 1,400,000$  psi (9646 N/mm<sup>2</sup>)**

$A_s/A_m$ <sup>1</sup>	$A_s$ <sup>1</sup> in. <sup>2</sup>	NUMBER OF FASTENERS IN A ROW										
	× 645.16 for mm <sup>2</sup>	2	3	4	5	6	7	8	9	10	11	12
0.5	5	0.98	0.92	0.84	0.75	0.68	0.61	0.55	0.50	0.45	0.41	0.38
	12	0.99	0.96	0.92	0.87	0.81	0.76	0.70	0.65	0.61	0.57	0.53
	20	0.99	0.98	0.95	0.91	0.87	0.83	0.78	0.74	0.70	0.66	0.62
	28	1.00	0.98	0.96	0.93	0.90	0.87	0.83	0.79	0.76	0.72	0.69
	40	1.00	0.99	0.97	0.95	0.93	0.90	0.87	0.84	0.81	0.78	0.75
	64	1.00	0.99	0.98	0.97	0.95	0.93	0.91	0.89	0.87	0.84	0.82
1	5	1.00	0.97	0.91	0.85	0.78	0.71	0.64	0.59	0.54	0.49	0.45
	12	1.00	0.99	0.96	0.93	0.88	0.84	0.79	0.74	0.70	0.65	0.61
	20	1.00	0.99	0.98	0.95	0.92	0.89	0.86	0.82	0.78	0.75	0.71
	28	1.00	0.99	0.98	0.97	0.94	0.92	0.89	0.86	0.83	0.80	0.77
	40	1.00	1.00	0.99	0.98	0.96	0.94	0.92	0.90	0.87	0.85	0.82
	64	1.00	1.00	0.99	0.98	0.97	0.96	0.95	0.93	0.91	0.90	0.88

<sup>1</sup>When  $A_s/A_m > 1.0$ , use  $A_s/A_m$  and use  $A_m$  instead of  $A_s$ .

<sup>2</sup>Tabulated group action factors ( $C_g$ ) are conservative for  $D < 1$  inch (25 mm),  $s < 4$  inches (102 mm) or  $E > 1,400,000$  psi (9646 N/mm<sup>2</sup>).

**TABLE 23-III-D—GROUP ACTION FACTORS,  $C_g$ , FOR 4-INCH (102 mm) SPLIT RING OR SHEAR PLATE CONNECTORS WITH WOOD SIDE MEMBERS<sup>1</sup> FOR  $s = 9$  INCHES (229 mm)  $E = 1,400,000$  psi (9646 N/mm<sup>2</sup>)**

$A_s/A_m$ <sup>2</sup>	$A_s$ <sup>1</sup> in. <sup>2</sup>	NUMBER OF FASTENERS IN A ROW										
	$\times 645.16$ for mm <sup>2</sup>	2	3	4	5	6	7	8	9	10	11	12
0.5	5	0.90	0.73	0.59	0.48	0.41	0.35	0.31	0.27	0.25	0.22	0.20
	12	0.95	0.83	0.71	0.60	0.52	0.45	0.40	0.36	0.32	0.29	0.27
	20	0.97	0.88	0.78	0.69	0.60	0.53	0.47	0.43	0.39	0.35	0.32
	28	0.97	0.91	0.82	0.74	0.66	0.59	0.53	0.48	0.44	0.40	0.37
	40	0.98	0.93	0.86	0.79	0.72	0.65	0.59	0.54	0.49	0.45	0.42
	64	0.99	0.95	0.91	0.85	0.79	0.73	0.67	0.62	0.58	0.54	0.50
1	5	1.00	0.87	0.72	0.59	0.50	0.43	0.38	0.34	0.30	0.28	0.25
	12	1.00	0.93	0.83	0.72	0.63	0.55	0.48	0.43	0.39	0.36	0.33
	20	1.00	0.95	0.88	0.79	0.71	0.63	0.57	0.51	0.46	0.42	0.39
	28	1.00	0.97	0.91	0.83	0.76	0.69	0.62	0.57	0.52	0.47	0.44
	40	1.00	0.98	0.93	0.87	0.81	0.75	0.69	0.63	0.58	0.54	0.50
	64	1.00	0.98	0.95	0.91	0.87	0.82	0.77	0.72	0.67	0.62	0.58

<sup>1</sup>Tabulated group action factors ( $C_g$ ) are conservative for 2<sup>1</sup>/<sub>2</sub>-inch (64 mm) split ring connectors, 2<sup>3</sup>/<sub>8</sub>-inch (67 mm) shear plate connectors,  $s < 9$  inches (229 mm) or  $E > 1,400,000$  psi (9646 N/mm<sup>2</sup>).

<sup>2</sup>When  $A_s/A_m > 1.0$ , use  $A_s/A_m$  and use  $A_m$  instead of  $A_s$ .

TABLE 23-III-E—GROUP ACTION FACTORS,  $C_g$ , FOR BOLT OR LAG SCREW CONNECTIONS WITH STEEL SIDE PLATES<sup>1</sup>  
 FOR  $D = 1$  INCH (25 mm),  $s = 4$  INCHES (102 mm),  $E_{\text{wood}} = 1,400,000$  psi (9646 N/mm<sup>2</sup>),  $E_{\text{steel}} = 30,000,000$  psi (206 700 N/mm<sup>2</sup>)

$A_s/A_m$	$A_m$ in. <sup>2</sup>	NUMBER OF FASTENERS IN A ROW										
	$\times 645.16$ for mm <sup>2</sup>	2	3	4	5	6	7	8	9	10	11	12
12	5	0.97	0.89	0.80	0.70	0.62	0.55	0.49	0.44	0.40	0.37	0.34
	8	0.98	0.93	0.85	0.77	0.70	0.63	0.57	0.52	0.47	0.43	0.40
	16	0.99	0.96	0.92	0.86	0.80	0.75	0.69	0.64	0.60	0.55	0.52
	24	0.99	0.97	0.94	0.90	0.85	0.81	0.76	0.71	0.67	0.63	0.59
	40	1.00	0.98	0.96	0.94	0.90	0.87	0.83	0.79	0.76	0.72	0.69
	64	1.00	0.99	0.98	0.96	0.94	0.91	0.88	0.86	0.83	0.80	0.77
	120	1.00	0.99	0.99	0.98	0.96	0.95	0.93	0.91	0.90	0.87	0.85
	200	1.00	1.00	0.99	0.99	0.98	0.97	0.96	0.95	0.93	0.92	0.90
18	5	0.99	0.93	0.85	0.76	0.68	0.61	0.54	0.49	0.44	0.41	0.37
	8	0.99	0.95	0.90	0.83	0.75	0.69	0.62	0.57	0.52	0.48	0.44
	16	1.00	0.98	0.94	0.90	0.85	0.79	0.74	0.69	0.65	0.60	0.56
	24	1.00	0.98	0.96	0.93	0.89	0.85	0.80	0.76	0.72	0.68	0.64
	40	1.00	0.99	0.97	0.95	0.93	0.90	0.87	0.83	0.80	0.77	0.73
	64	1.00	0.99	0.98	0.97	0.95	0.93	0.91	0.89	0.86	0.83	0.81
	120	1.00	1.00	0.99	0.98	0.97	0.96	0.95	0.93	0.92	0.90	0.88
	200	1.00	1.00	0.99	0.99	0.98	0.98	0.97	0.96	0.95	0.94	0.92
24	40	1.00	0.99	0.97	0.95	0.93	0.89	0.86	0.83	0.79	0.76	0.72
	64	1.00	0.99	0.98	0.97	0.95	0.93	0.91	0.88	0.85	0.83	0.80
	120	1.00	1.00	0.99	0.98	0.97	0.96	0.95	0.93	0.91	0.90	0.88
	200	1.00	1.00	0.99	0.99	0.98	0.98	0.97	0.96	0.95	0.93	0.92
30	40	1.00	0.98	0.96	0.93	0.89	0.85	0.81	0.77	0.73	0.69	0.65
	64	1.00	0.99	0.97	0.95	0.93	0.90	0.87	0.83	0.80	0.77	0.73
	120	1.00	0.99	0.99	0.97	0.96	0.94	0.92	0.90	0.88	0.85	0.83
	200	1.00	1.00	0.99	0.98	0.97	0.96	0.95	0.94	0.92	0.90	0.89
35	40	0.99	0.97	0.94	0.91	0.86	0.82	0.77	0.73	0.68	0.64	0.60
	64	1.00	0.98	0.96	0.94	0.91	0.87	0.84	0.80	0.76	0.73	0.69
	120	1.00	0.99	0.98	0.97	0.95	0.92	0.90	0.88	0.85	0.82	0.79
	200	1.00	0.99	0.99	0.98	0.97	0.95	0.94	0.92	0.90	0.88	0.86

42	40	0.99	0.97	0.93	0.88	0.83	0.78	0.73	0.68	0.63	0.59	0.55
	64	0.99	0.98	0.95	0.92	0.88	0.84	0.80	0.76	0.72	0.68	0.64
	120	1.00	0.99	0.97	0.95	0.93	0.90	0.88	0.85	0.81	0.78	0.75
	200	1.00	0.99	0.98	0.97	0.96	0.94	0.92	0.90	0.88	0.85	0.83
50	40	0.99	0.96	0.91	0.85	0.79	0.74	0.68	0.63	0.58	0.54	0.51
	64	0.99	0.97	0.94	0.90	0.85	0.81	0.76	0.72	0.67	0.63	0.59
	120	1.00	0.98	0.97	0.94	0.91	0.88	0.85	0.81	0.78	0.74	0.71
	200	1.00	0.99	0.98	0.96	0.95	0.92	0.90	0.87	0.85	0.82	0.79

<sup>1</sup>Tabulated group action factors ( $C_g$ ) are conservative for  $D < 1$  inch (25 mm) or  $s < 4$  inches (102 mm).

TABLE 23-III-F—GROUP ACTION FACTORS,  $C_g$ , FOR 4-INCH (102 mm) SHEAR PLATE CONNECTORS WITH STEEL SIDE PLATES<sup>1</sup>  
 FOR  $s = 9$  INCHES (229 mm),  $E_{\text{wood}} = 1,400,000$  psi (9646 N/mm<sup>2</sup>),  $E_{\text{steel}} = 30,000,000$  psi (206 700 N/mm<sup>2</sup>)

$A_g/A_m$	$A_m$ in. <sup>2</sup>	NUMBER OF FASTENERS IN A ROW										
	× 645.16 for mm <sup>2</sup>	2	3	4	5	6	7	8	9	10	11	12
12	5	0.91	0.75	0.60	0.50	0.42	0.36	0.31	0.28	0.25	0.23	0.21
	8	0.94	0.80	0.67	0.56	0.47	0.41	0.36	0.32	0.29	0.26	0.24
	16	0.96	0.87	0.76	0.66	0.58	0.51	0.45	0.40	0.37	0.33	0.31
	24	0.97	0.90	0.82	0.73	0.64	0.57	0.51	0.46	0.42	0.39	0.35
	40	0.98	0.94	0.87	0.80	0.73	0.66	0.60	0.55	0.50	0.46	0.43
	64	0.99	0.96	0.91	0.86	0.80	0.74	0.69	0.63	0.59	0.55	0.51
	120	0.99	0.98	0.95	0.91	0.87	0.83	0.79	0.74	0.70	0.66	0.63
200	1.00	0.99	0.97	0.95	0.92	0.89	0.85	0.82	0.79	0.75	0.72	
18	5	0.97	0.83	0.68	0.56	0.47	0.41	0.36	0.32	0.28	0.26	0.24
	8	0.98	0.87	0.74	0.62	0.53	0.46	0.40	0.36	0.32	0.30	0.27
	16	0.99	0.92	0.82	0.73	0.64	0.56	0.50	0.45	0.41	0.37	0.34
	24	0.99	0.94	0.87	0.78	0.70	0.63	0.57	0.51	0.47	0.43	0.39
	40	0.99	0.96	0.91	0.85	0.78	0.72	0.66	0.60	0.55	0.51	0.47
	64	1.00	0.97	0.94	0.89	0.84	0.79	0.74	0.69	0.64	0.60	0.56
	120	1.00	0.99	0.97	0.94	0.90	0.87	0.83	0.79	0.75	0.71	0.67
200	1.00	0.99	0.98	0.96	0.94	0.91	0.89	0.86	0.82	0.79	0.76	
24	40	1.00	0.96	0.91	0.84	0.77	0.71	0.65	0.59	0.54	0.50	0.46
	64	1.00	0.98	0.94	0.89	0.84	0.78	0.73	0.68	0.63	0.58	0.54
	120	1.00	0.99	0.96	0.94	0.90	0.86	0.82	0.78	0.74	0.70	0.66
	200	1.00	0.99	0.98	0.96	0.94	0.91	0.88	0.85	0.82	0.78	0.75
30	40	0.99	0.93	0.86	0.78	0.70	0.63	0.57	0.52	0.47	0.43	0.40
	64	0.99	0.96	0.90	0.84	0.78	0.71	0.66	0.60	0.56	0.51	0.48
	120	0.99	0.98	0.94	0.90	0.86	0.81	0.76	0.71	0.67	0.63	0.59
	200	1.00	0.98	0.96	0.94	0.91	0.87	0.83	0.79	0.76	0.72	0.68
35	40	0.98	0.91	0.83	0.74	0.66	0.59	0.53	0.48	0.43	0.40	0.36
	64	0.99	0.94	0.88	0.81	0.73	0.67	0.61	0.56	0.51	0.47	0.43
	120	0.99	0.97	0.93	0.88	0.82	0.77	0.72	0.67	0.62	0.58	0.54
	200	1.00	0.98	0.95	0.92	0.88	0.84	0.80	0.76	0.71	0.68	0.64

42	40	0.97	0.88	0.79	0.69	0.61	0.54	0.48	0.43	0.39	0.36	0.33
	64	0.98	0.92	0.84	0.76	0.69	0.62	0.56	0.51	0.46	0.42	0.39
	120	0.99	0.95	0.90	0.85	0.78	0.72	0.67	0.62	0.57	0.53	0.49
	200	0.99	0.97	0.94	0.90	0.85	0.80	0.76	0.71	0.67	0.62	0.59
50	40	0.95	0.86	0.75	0.65	0.56	0.49	0.44	0.39	0.35	0.32	0.30
	64	0.97	0.90	0.81	0.72	0.64	0.57	0.51	0.46	0.42	0.38	0.35
	120	0.98	0.94	0.88	0.81	0.74	0.68	0.62	0.57	0.52	0.48	0.45
	200	0.99	0.96	0.92	0.87	0.82	0.77	0.71	0.66	0.62	0.58	0.54

<sup>1</sup>Tabulated group action factors ( $C_g$ ) are conservative for 2<sup>5</sup>/<sub>8</sub>-inch (67 mm) shear plate connectors or  $s < 9$  inches (229 mm).

TABLE 23-III-G—DOWEL-BEARING STRENGTH FOR BOLTED CONNECTIONS

SPECIES COMBINATION	SPECIFIC <sup>1</sup> GRAVITY G	DOWEL-BEARING STRENGTH IN POUNDS PER SQUARE INCH (psi)					
		$\times 6.89 \times 10^{-3}$ for N/mm <sup>2</sup>					
		$F_{e  }$	$F_{e\perp}$ D = 1/2 inch (13 mm)	$F_{e\perp}$ D = 5/8 inch (16 mm)	$F_{e\perp}$ D = 3/4 inch (19 mm)	$F_{e\perp}$ D = 7/8 inch (22 mm)	$F_{e\perp}$ D = 1 inch (25 mm)
Aspen	0.39	4,350	2,200	1,950	1,800	1,650	1,550
Balsam fir	0.36	4,050	1,950	1,750	1,600	1,500	1,400
Beech-birch-hickory	0.71	7,950	5,250	4,700	4,300	3,950	3,700
Coast sitka spruce	0.39	4,350	2,200	1,950	1,800	1,650	1,550
Cottonwood	0.41	4,600	2,350	2,100	1,950	1,800	1,650
Douglas fir-larch	0.50	5,600	3,150	2,800	2,600	2,400	2,250
Douglas fir-larch (north)	0.49	5,500	3,050	2,750	2,500	2,300	2,150
Douglas fir-south	0.46	5,150	2,800	2,500	2,300	2,100	2,000
Eastern hemlock	0.41	4,600	2,350	2,100	1,950	1,800	1,650
Eastern hemlock-tamarack	0.41	4,600	2,350	2,100	1,950	1,800	1,650
Eastern hemlock-tamarack (north)	0.47	5,250	2,900	2,600	2,350	2,200	2,050
Eastern softwoods	0.36	4,050	1,950	1,750	1,600	1,500	1,400
Eastern spruce	0.41	4,600	2,350	2,100	1,950	1,800	1,650
Eastern white pine	0.36	4,050	1,950	1,750	1,600	1,500	1,400
Engelmann spruce-lodgepole pine <sup>2</sup> (MSR 1650f and higher grades)	0.46	5,150	2,800	2,500	2,300	2,100	2,000
Engelmann spruce-lodgepole pine <sup>2</sup> (MSR 1500f and lower grades)	0.38	4,250	2,100	1,900	1,750	1,600	1,500

(Continued)

TABLE 23-III-G—DOWEL-BEARING STRENGTH FOR BOLTED CONNECTIONS—(Continued)

SPECIES COMBINATION	SPECIFIC <sup>1</sup> GRAVITY G	DOWEL-BEARING STRENGTH IN POUNDS PER SQUARE INCH (psi)					
		× 6.89 × 10 <sup>-3</sup> for N/mm <sup>2</sup>					
		$F_{e  }$	$F_{e\perp}$ D = 1/2 inch (13 mm)	$F_{e\perp}$ D = 5/8 inch (16 mm)	$F_{e\perp}$ D = 3/4 inch (19 mm)	$F_{e\perp}$ D = 7/8 inch (22 mm)	$F_{e\perp}$ D = 1 inch (25 mm)
Hem-fir	0.43	4,800	2,550	2,250	2,050	1,900	1,800
Hem-fir (north)	0.46	5,150	2,800	2,500	2,300	2,100	2,000
Mixed maple	0.55	6,150	3,650	3,250	2,950	2,750	2,550
Mixed oak	0.68	7,600	4,950	4,400	4,050	3,750	3,500
Mixed southern pine	0.51	5,700	3,250	2,900	2,650	2,450	2,300
Mountain hemlock	0.47	5,250	2,900	2,600	2,350	2,200	2,050
Northern pine	0.42	4,700	2,450	2,200	2,000	1,850	1,750
Northern red oak	0.68	7,600	4,950	4,400	4,050	3,750	3,500
Northern species	0.35	3,900	1,900	1,700	1,550	1,400	1,350
Northern white cedar	0.31	3,450	1,600	1,400	1,300	1,200	1,100
Ponderosa pine	0.43	4,800	2,550	2,250	2,050	1,900	1,800
Red maple	0.58	6,500	3,900	3,500	3,200	2,950	2,750
Red oak	0.67	7,500	4,850	4,300	3,950	3,650	3,400
Red pine	0.44	4,950	2,600	2,350	2,150	2,000	1,850
Redwood close grain	0.44	4,950	2,600	2,350	2,150	2,000	1,850
Redwood open grain	0.37	4,150	2,050	1,850	1,650	1,550	1,450
Sitka spruce	0.43	4,800	2,550	2,250	2,050	1,900	1,800
Southern pine	0.55	6,150	3,650	3,250	2,950	2,750	2,550
Spruce-pine-fir	0.42	4,700	2,450	2,200	2,000	1,850	1,750
Spruce-pine-fir (south)	0.36	4,050	1,950	1,750	1,600	1,500	1,400
Western cedars	0.36	4,050	1,950	1,750	1,600	1,500	1,400
Western cedars (north)	0.35	3,900	1,900	1,700	1,550	1,400	1,350
Western hemlock	0.47	5,250	2,900	2,600	2,350	2,200	2,050
Western hemlock (north)	0.46	5,150	2,800	2,500	2,300	2,100	2,000
Western white pine	0.40	4,500	2,300	2,050	1,850	1,750	1,600
Western woods	0.36	4,050	1,950	1,750	1,600	1,500	1,400
White oak	0.73	8,200	5,450	4,900	4,450	4,150	3,850
Yellow poplar	0.43	4,800	2,550	2,250	2,050	1,900	1,800

<sup>1</sup>Specific gravity based on weight and volume when oven dry.<sup>2</sup>Applies only to Engelmann spruce-lodgepole pine machine stress-rated (MSR) structural lumber.

TABLE 23-III-H—END DISTANCE REQUIREMENTS FOR BOLTS

DIRECTION OF LOADING	MINIMUM END DISTANCES	
	for Reduced Design Value	for Full Design Value
Perpendicular to grain	2D	4D
Parallel to grain, compression: (bolt bearing away from member end)	2D	4D
Parallel to grain, tension: (bolt bearing toward member end)		
For softwoods	3.5D	7D
For hardwoods	2.5D	5D

TABLE 23-III-I—SPACING REQUIREMENTS FOR BOLTS IN A ROW

DIRECTION OF LOADING	MINIMUM SPACING	
	for Reduced Design Value	for Full Design Value
Parallel to grain	3D	4D
Perpendicular to grain	3D	Required spacing for attached member(s)

**TABLE 23-III-J—BOLT DESIGN VALUES (Z) FOR SINGLE SHEAR (Two-member) CONNECTIONS<sup>1,2</sup> FOR SAWN LUMBER WITH BOTH MEMBERS OF IDENTICAL SPECIES**

THICKNESS		BOLT DIAMETER D inches	G = 0.67 RED OAK			G = 0.55 MIXED MAPLE SOUTHERN PINE			G = 0.50 DOUGLAS FIR-LARCH			G = 0.49 DOUGLAS FIR-LARCH (N)			G = 0.46 DOUGLAS FIR (S) HEM-FIR (N)			
Main Member t <sub>m</sub> inches	Side Member t <sub>s</sub> inches		Z <sub>  </sub> lbs.	Z <sub>⊥</sub> lbs.	Z <sub>m⊥</sub> lbs.	Z <sub>  </sub> lbs.	Z <sub>⊥</sub> lbs.	Z <sub>m⊥</sub> lbs.	Z <sub>  </sub> lbs.	Z <sub>⊥</sub> lbs.	Z <sub>m⊥</sub> lbs.	Z <sub>  </sub> lbs.	Z <sub>⊥</sub> lbs.	Z <sub>m⊥</sub> lbs.	Z <sub>  </sub> lbs.	Z <sub>⊥</sub> lbs.	Z <sub>m⊥</sub> lbs.	
× 25.4 for mm			× 4.45 for N															
1 1/2	1 1/2	1/2	650	420	420	530	330	330	480	300	300	470	290	290	440	270	270	
		5/8	810	500	500	660	400	400	600	360	360	590	350	350	560	320	320	
		3/4	970	580	580	800	460	460	720	420	420	710	400	400	670	380	380	
		7/8	1,130	660	660	930	520	520	850	470	470	830	460	460	780	420	420	
		1	1,290	740	740	1,060	580	580	970	530	530	950	510	510	890	480	480	
2 1/2	1 1/2	1/2	770	480	540	660	400	420	610	370	370	610	360	360	580	340	330	
		5/8	1,070	660	630	930	560	490	850	520	430	830	520	420	780	470	390	
		3/4	1,360	890	720	1,120	660	560	1,020	590	500	1,000	560	480	940	520	450	
		7/8	1,590	960	800	1,300	720	620	1,190	630	550	1,170	600	540	1,090	550	500	
		1	1,820	1,020	870	1,490	770	680	1,360	680	610	1,330	650	590	1,250	600	550	
3	1 1/2	1/2	770	480	560	660	400	470	610	370	420	610	360	410	580	340	380	
		5/8	1,070	660	710	940	560	550	880	520	480	870	520	470	830	470	440	
		3/4	1,450	890	800	1,270	660	620	1,190	590	550	1,170	560	530	1,090	520	500	
		7/8	1,860	960	890	1,520	720	690	1,390	630	610	1,360	600	590	1,280	550	540	
		1	2,120	1,020	970	1,740	770	750	1,590	680	670	1,560	650	650	1,460	600	600	
3 1/2	1 1/2	1/2	770	480	560	660	400	470	610	370	430	610	360	420	580	340	400	
		5/8	1,070	660	760	940	560	620	880	520	540	870	520	530	830	470	490	
		3/4	1,450	890	900	1,270	660	690	1,200	590	610	1,190	560	590	1,140	520	550	
		7/8	1,890	960	990	1,680	720	770	1,590	630	680	1,570	600	650	1,470	550	600	
		1	2,410	1,020	1,080	2,010	770	830	1,830	680	740	1,790	650	710	1,680	600	660	
	3 1/2	3 1/2	1/2	830	590	590	750	520	520	720	490	490	710	480	480	690	460	460
			5/8	1,290	880	880	1,170	780	780	1,120	700	700	1,110	690	690	1,070	650	650
			3/4	1,860	1,190	1,190	1,690	960	960	1,610	870	870	1,600	850	850	1,540	800	800
			7/8	2,540	1,410	1,410	2,170	1,160	1,160	1,970	1,060	1,060	1,940	1,040	1,040	1,810	980	980
			1	3,020	1,670	1,670	2,480	1,360	1,360	2,260	1,230	1,230	2,210	1,190	1,190	2,070	1,110	1,110
4 1/2	1 1/2	5/8	1,070	660	760	940	560	640	880	520	590	870	520	590	830	470	560	
		3/4	1,450	890	990	1,270	660	840	1,200	590	750	1,190	560	720	1,140	520	670	
		7/8	1,890	960	1,210	1,680	720	930	1,590	630	820	1,570	600	790	1,520	550	730	
		1	2,410	1,020	1,310	2,150	770	1,000	2,050	680	890	2,030	650	860	1,930	600	800	
		3 1/2	1,290	880	880	1,170	780	780	1,120	700	730	1,110	690	720	1,070	650	690	
	3 1/2	3 1/2	5/8	1,860	1,190	1,240	1,690	960	1,090	1,610	870	1,000	1,600	850	980	1,540	800	910
			3/4	2,540	1,410	1,630	2,300	1,160	1,300	2,190	1,060	1,160	2,170	1,040	1,130	2,060	980	1,050
			7/8	3,310	1,670	1,830	2,870	1,390	1,440	2,610	1,290	1,290	2,560	1,260	1,250	2,400	1,210	1,170
			1															

5 1/2	1 1/2	5/8	1,070	660	760	940	560	640	880	520	590	870	520	590	830	470	560
		3/4	1,450	890	990	1,270	660	850	1,200	590	790	1,190	560	780	1,140	520	740
		7/8	1,890	960	1,260	1,680	720	1,090	1,590	630	980	1,570	600	940	1,520	550	860
		1	2,410	1,020	1,560	2,150	770	1,190	2,050	680	1,060	2,030	650	1,010	1,930	600	940
	3 1/2	5/8	1,290	880	880	1,170	780	780	1,120	700	730	1,110	690	720	1,070	650	690
		3/4	1,860	1,190	1,240	1,690	960	1,090	1,610	870	1,030	1,600	850	1,010	1,540	800	970
		7/8	2,540	1,410	1,640	2,300	1,160	1,410	2,190	1,060	1,260	2,170	1,040	1,220	2,060	980	1,130
		1	3,310	1,670	1,980	2,870	1,390	1,550	2,660	1,290	1,390	2,630	1,260	1,340	2,500	1,210	1,250
7 1/2	1 1/2	5/8	1,070	660	760	940	560	640	880	520	590	870	520	590	830	470	560
		3/4	1,450	890	990	1,270	660	850	1,200	590	790	1,190	560	780	1,140	520	740
		7/8	1,890	960	1,260	1,680	720	1,090	1,590	630	1,010	1,570	600	990	1,520	550	950
		1	2,410	1,020	1,560	2,150	770	1,350	2,050	680	1,270	2,030	650	1,240	1,930	600	1,190
	3 1/2	5/8	1,290	880	880	1,170	780	780	1,120	700	730	1,110	690	720	1,070	650	690
		3/4	1,860	1,190	1,240	1,690	960	1,090	1,610	870	1,030	1,600	850	1,010	1,540	800	970
		7/8	2,540	1,410	1,640	2,300	1,160	1,450	2,190	1,060	1,360	2,170	1,040	1,340	2,060	980	1,280
		1	3,310	1,670	2,090	2,870	1,390	1,830	2,660	1,290	1,630	2,630	1,260	1,570	2,500	1,210	1,470

<sup>1</sup>Tabulated lateral design values (Z) for bolted connections shall be multiplied by all applicable adjustment factors (see Table 23-III-A).

<sup>2</sup>Tabulated lateral design values (Z) are for "full diameter" bolts with a bending yield strength ( $F_{yb}$ ) of 45,000 psi (310 N/mm<sup>2</sup>).

TABLE 23-III-J—BOLT DESIGN VALUES (Z) FOR SINGLE SHEAR (Two-member) CONNECTIONS<sup>1,2</sup>  
FOR SAWN LUMBER WITH BOTH MEMBERS OF IDENTICAL SPECIES—(Continued)

THICKNESS		BOLT DIAMETER D inches	G = 0.43 HEM-FIR			G = 0.42 SPRUCE-PINE-FIR			G = 0.37 REDWOOD (open grain)			G = 0.36 EASTERN SOFTWOODS SPRUCE-PINE-FIR (S) WESTERN CEDARS WESTERN WOODS			G = 0.35 NORTHERN SPECIES			
Main Member t <sub>m</sub> inches	Side Member t <sub>s</sub> inches		Z <sub>  </sub> lbs.	Z <sub>⊥</sub> lbs.	Z <sub>m⊥</sub> lbs.	Z <sub>  </sub> lbs.	Z <sub>⊥</sub> lbs.	Z <sub>m⊥</sub> lbs.	Z <sub>  </sub> lbs.	Z <sub>⊥</sub> lbs.	Z <sub>m⊥</sub> lbs.	Z <sub>  </sub> lbs.	Z <sub>⊥</sub> lbs.	Z <sub>m⊥</sub> lbs.	Z <sub>  </sub> lbs.	Z <sub>⊥</sub> lbs.	Z <sub>m⊥</sub> lbs.	
× 25.4 for mm			× 4.45 for N															
1½	1½	½	410	250	250	410	240	240	360	210	210	350	200	200	340	200	200	
		5/8	520	300	300	510	290	290	450	250	250	440	240	240	420	240	240	
		¾	620	350	350	610	340	340	540	290	290	520	280	280	500	270	270	
		7/8	720	390	390	710	380	380	630	330	330	610	320	320	590	310	310	
		1	830	440	440	810	430	430	720	370	370	700	360	360	670	350	350	
2½	1½	½	550	320	310	540	320	300	500	290	250	490	280	240	470	280	240	
		5/8	730	420	360	710	410	350	630	350	300	610	330	290	590	320	280	
		¾	870	460	410	850	450	400	750	370	340	740	360	330	710	350	320	
		7/8	1,020	500	450	1,000	490	440	880	410	380	860	390	370	830	370	350	
		1	1,160	540	500	1,140	530	490	1,010	440	420	980	420	410	940	410	390	
3	1½	½	550	320	350	540	320	330	500	290	280	490	280	270	480	280	260	
		5/8	790	420	400	780	410	390	720	350	330	710	330	320	690	320	310	
		¾	1,020	460	450	1,000	450	440	880	370	370	860	360	360	830	350	350	
		7/8	1,190	500	500	1,160	490	490	1,030	410	420	1,000	390	400	970	370	380	
		1	1,360	540	550	1,330	530	540	1,170	440	460	1,150	420	440	1,100	410	430	
3½	1½	½	550	320	380	540	320	370	500	290	320	490	280	300	480	280	290	
		5/8	790	420	440	780	410	430	720	350	370	710	330	350	700	320	340	
		¾	1,100	460	500	1,080	450	480	1,010	370	410	990	360	400	950	350	380	
		7/8	1,370	500	550	1,340	490	540	1,180	410	460	1,160	390	440	1,110	370	420	
		1	1,570	540	600	1,530	530	590	1,350	440	500	1,320	420	480	1,270	410	470	
	3½	3½	½	660	440	440	660	430	430	620	400	400	610	390	390	600	380	380
			5/8	1,040	600	600	1,020	590	590	960	520	520	950	500	500	930	490	490
			¾	1,450	740	740	1,420	730	730	1,250	650	650	1,220	630	630	1,180	620	620
			7/8	1,690	910	910	1,660	890	890	1,460	770	770	1,430	750	750	1,370	720	720
			1	1,930	1,030	1,030	1,890	1,000	1,000	1,670	870	870	1,630	840	840	1,570	810	810

4 <sup>1/2</sup>	1 <sup>1/2</sup>	5/8	790	420	530	780	410	520	720	350	450	710	330	430	700	320	410
		3/4	1,100	460	600	1,080	450	590	1,010	370	490	990	360	480	970	350	460
		7/8	1,460	500	660	1,440	490	640	1,350	410	550	1,330	390	530	1,280	370	500
	1	1,800	540	720	1,760	530	710	1,560	440	590	1,520	420	570	1,460	410	550	
	3 <sup>1/2</sup>	5/8	1,040	600	660	1,020	590	650	960	520	600	950	500	570	930	490	560
		3/4	1,490	740	840	1,480	730	820	1,390	650	720	1,370	630	700	1,330	620	670
7/8		1,950	920	960	1,920	910	940	1,690	820	810	1,650	800	790	1,590	770	750	
1	2,240	1,140	1,070	2,190	1,120	1,050	1,940	1,020	900	1,890	980	880	1,820	950	840		
5 <sup>1/2</sup>	1 <sup>1/2</sup>	5/8	790	420	530	780	410	520	720	350	470	710	330	460	700	320	450
		3/4	1,100	460	700	1,080	450	690	1,010	370	580	990	360	570	970	350	550
		7/8	1,460	500	780	1,440	490	760	1,350	410	650	1,330	390	630	1,280	370	590
	1	1,800	540	860	1,760	530	830	1,560	440	700	1,520	420	680	1,460	410	650	
	3 <sup>1/2</sup>	5/8	1,040	600	660	1,020	590	650	960	520	610	950	500	590	930	490	580
		3/4	1,490	740	920	1,480	730	900	1,390	650	770	1,370	630	750	1,330	620	720
7/8		1,950	920	1,030	1,920	910	1,010	1,740	820	870	1,710	800	840	1,660	770	800	
1	2,370	1,140	1,150	2,330	1,120	1,120	2,120	1,020	960	2,080	980	930	2,030	950	890		
7 <sup>1/2</sup>	1 <sup>1/2</sup>	5/8	790	420	530	780	410	520	720	350	470	710	330	460	700	320	450
		3/4	1,100	460	700	1,080	450	690	1,010	370	630	990	360	620	970	350	600
		7/8	1,460	500	900	1,440	490	890	1,350	410	810	1,330	390	800	1,280	370	770
	1	1,800	540	1,130	1,760	530	1,110	1,560	440	920	1,520	420	890	1,460	410	860	
	3 <sup>1/2</sup>	5/8	1,040	600	660	1,020	590	650	960	520	610	950	500	590	930	490	580
		3/4	1,490	740	920	1,480	730	910	1,390	650	840	1,370	630	820	1,330	620	810
7/8		1,950	920	1,210	1,920	910	1,180	1,740	820	1,010	1,710	800	980	1,660	770	920	
1	2,370	1,140	1,340	2,330	1,120	1,300	2,120	1,020	1,100	2,080	980	1,070	2,030	950	1,030		

<sup>1</sup>Tabulated lateral design values (Z) for bolted connections shall be multiplied by all applicable adjustment factors (see Table 23-III-A).

<sup>2</sup>Tabulated lateral design values (Z) are for "full diameter" bolts with a bending yield strength ( $F_{yb}$ ) of 45,000 psi (310 N/mm<sup>2</sup>).

TABLE 23-III-K—BOLT DESIGN VALUES (Z) FOR SINGLE SHEAR (Two-member) CONNECTIONS<sup>1,2,3</sup>  
FOR SAWN LUMBER WITH 1/4-INCH (6.4 mm) ASTM A 36 STEEL SIDE PLATE

THICKNESS		BOLT DIAMETER D Inches	G = 0.67 RED OAK		G = 0.55 MIXED MAPLE SOUTHERN PINE		G = 0.50 DOUGLAS FIR-LARCH		G = 0.49 DOUGLAS FIR-LARCH (N)		G = 0.46 DOUGLAS FIR (S) HEM-FIR (N)	
Main Member $t_m$ inches	Steel Side Plate $t_s$ inches		Z <sub>  </sub> lbs.	Z <sub>⊥</sub> lbs.	Z <sub>  </sub> lbs.	Z <sub>⊥</sub> lbs.	Z <sub>  </sub> lbs.	Z <sub>⊥</sub> lbs.	Z <sub>  </sub> lbs.	Z <sub>⊥</sub> lbs.	Z <sub>  </sub> lbs.	Z <sub>⊥</sub> lbs.
× 25.4 for mm			× 4.45 for N									
1 1/2	1/4	1/2	670	380	570	310	530	270	520	270	500	250
		5/8	840	430	710	350	660	320	650	310	620	290
		3/4	1,010	490	860	390	800	360	780	350	740	330
		7/8	1,180	540	1,000	440	930	400	920	390	870	370
		1	1,350	580	1,140	480	1,060	440	1,050	430	990	410
2 1/2	1/4	1/2	850	570	780	440	750	390	750	380	730	350
		5/8	1,270	640	1,100	500	1,010	440	990	430	940	400
		3/4	1,580	710	1,320	550	1,210	490	1,190	480	1,120	450
		7/8	1,850	770	1,540	610	1,410	540	1,390	520	1,310	480
		1	2,110	830	1,760	650	1,620	590	1,590	560	1,500	530
3	1/4	1/2	850	570	780	500	750	450	750	440	730	410
		5/8	1,270	750	1,170	580	1,130	510	1,120	500	1,090	460
		3/4	1,800	830	1,560	640	1,430	570	1,410	550	1,330	510
		7/8	2,200	900	1,830	700	1,670	620	1,650	600	1,550	550
		1	2,510	970	2,090	750	1,910	670	1,880	650	1,770	610
3 1/2	1/4	1/2	850	570	780	500	750	470	750	460	730	450
		5/8	1,270	800	1,170	670	1,130	580	1,120	570	1,090	520
		3/4	1,800	960	1,650	730	1,580	650	1,570	630	1,530	580
		7/8	2,420	1,040	2,120	800	1,940	710	1,900	680	1,790	630
		1	2,920	1,110	2,420	850	2,210	760	2,180	730	2,050	690
4 1/2	1/4	5/8	1,270	800	1,170	710	1,130	660	1,120	660	1,090	630
		3/4	1,800	1,090	1,650	920	1,580	820	1,570	790	1,530	730
		7/8	2,420	1,310	2,220	1,010	2,130	880	2,110	850	2,050	780
		1	3,140	1,400	2,880	1,070	2,760	950	2,740	910	2,610	850

5 <sup>1</sup> / <sub>2</sub>	1 <sup>1</sup> / <sub>4</sub>	5 <sup>5</sup> / <sub>8</sub>	1,270	800	1,170	710	1,130	660	1,120	660	1,090	630
		3 <sup>3</sup> / <sub>4</sub>	1,800	1,090	1,650	950	1,580	900	1,570	880	1,530	850
		7 <sup>7</sup> / <sub>8</sub>	2,420	1,410	2,220	1,220	2,130	1,070	2,110	1,030	2,050	940
		1	3,140	1,700	2,880	1,290	2,760	1,150	2,740	1,100	2,660	1,030
7 <sup>1</sup> / <sub>2</sub>	1 <sup>1</sup> / <sub>4</sub>	5 <sup>5</sup> / <sub>8</sub>	1,270	800	1,170	710	1,130	660	1,120	660	1,090	630
		3 <sup>3</sup> / <sub>4</sub>	1,800	1,090	1,650	950	1,580	900	1,570	880	1,530	850
		7 <sup>7</sup> / <sub>8</sub>	2,420	1,410	2,220	1,240	2,130	1,160	2,110	1,140	2,050	1,090
		1	3,140	1,760	2,880	1,540	2,760	1,460	2,740	1,420	2,660	1,380
9 <sup>1</sup> / <sub>2</sub>	1 <sup>1</sup> / <sub>4</sub>	3 <sup>3</sup> / <sub>4</sub>	1,800	1,090	1,650	950	1,580	900	1,570	880	1,530	850
		7 <sup>7</sup> / <sub>8</sub>	2,420	1,410	2,220	1,240	2,130	1,160	2,110	1,140	2,050	1,090
		1	3,140	1,760	2,880	1,540	2,760	1,460	2,740	1,420	2,660	1,380
11 <sup>1</sup> / <sub>2</sub>	1 <sup>1</sup> / <sub>4</sub>	7 <sup>7</sup> / <sub>8</sub>	2,420	1,410	2,220	1,240	2,130	1,160	2,110	1,140	2,050	1,090
		1	3,140	1,760	2,880	1,540	2,760	1,460	2,740	1,420	2,660	1,380
13 <sup>1</sup> / <sub>2</sub>	1 <sup>1</sup> / <sub>4</sub>	1	3,140	1,760	2,880	1,540	2,760	1,460	2,740	1,420	2,660	1,380

1994 UNIFORM BUILDING CODE

23-III-K

TABLE 23-III-K—BOLT DESIGN VALUES (Z) FOR SINGLE SHEAR (Two-member) CONNECTIONS<sup>1,2,3</sup>  
FOR SAWN LUMBER WITH 1/4-INCH (6.4 mm) ASTM A 36 STEEL SIDE PLATE—(Continued)

THICKNESS		BOLT DIAMETER D inches	G = 0.43 HEM-FIR		G = 0.42 SPRUCE-PINE-FIR		G = 0.37 REDWOOD (open grain)		G = 0.36 EASTERN SOFTWOODS SPRUCE-PINE-FIR(S) WESTERN CEDARS WESTERN WOODS		G = 0.35 NORTHERN SPECIES	
Main Member $t_m$ inches	Steel Side Plate $t_s$ inches		Z <sub>  </sub> lbs.	Z <sub>⊥</sub> lbs.	Z <sub>  </sub> lbs.	Z <sub>⊥</sub> lbs.	Z <sub>  </sub> lbs.	Z <sub>⊥</sub> lbs.	Z <sub>  </sub> lbs.	Z <sub>⊥</sub> lbs.	Z <sub>  </sub> lbs.	Z <sub>⊥</sub> lbs.
× 25.4 for mm			× 4.45 for N									
1 1/2	1/4	1/2	470	240	460	230	420	210	410	200	400	200
		5/8	590	270	580	270	530	240	520	230	500	230
		3/4	700	310	690	300	630	270	620	270	600	260
		7/8	820	340	810	340	740	300	720	300	700	290
		1	940	380	920	370	840	340	830	330	800	320
2 1/2	1/4	1/2	700	320	690	310	620	270	600	260	580	260
		5/8	880	370	860	360	770	310	760	300	730	290
		3/4	1,050	410	1,030	400	930	340	910	330	880	330
		7/8	1,230	450	1,210	440	1,080	380	1,060	370	1,020	350
		1	1,410	490	1,380	480	1,240	410	1,210	400	1,170	390
3	1/4	1/2	710	370	700	360	660	310	660	300	650	290
		5/8	1,040	420	1,020	410	910	360	890	340	860	330
		3/4	1,240	470	1,220	460	1,090	390	1,060	380	1,030	370
		7/8	1,450	510	1,420	500	1,270	430	1,240	420	1,200	400
		1	1,660	560	1,630	540	1,450	460	1,420	450	1,370	440
3 1/2	1/4	1/2	710	430	700	410	660	350	660	340	650	330
		5/8	1,050	480	1,040	470	990	400	980	380	960	370
		3/4	1,440	530	1,410	520	1,250	440	1,230	420	1,180	410
		7/8	1,680	570	1,640	560	1,460	480	1,430	470	1,380	440
		1	1,910	630	1,880	610	1,670	520	1,630	500	1,580	490
4 1/2	1/4	5/8	1,050	600	1,040	580	990	500	980	470	960	460
		3/4	1,480	660	1,470	640	1,390	540	1,370	520	1,350	510
		7/8	1,990	710	1,970	700	1,860	590	1,810	570	1,750	540
		1	2,440	770	2,390	750	2,120	640	2,070	620	2,000	600

5 <sup>1</sup> / <sub>2</sub>	1 <sup>1</sup> / <sub>4</sub>	5 <sup>5</sup> / <sub>8</sub>	1,050	600	1,040	600	990	550	980	540	960	530
		3 <sup>3</sup> / <sub>4</sub>	1,480	790	1,470	770	1,390	640	1,370	620	1,350	610
		7 <sup>7</sup> / <sub>8</sub>	1,990	860	1,970	830	1,860	710	1,840	680	1,810	640
		1	2,580	930	2,550	900	2,410	760	2,390	730	2,350	710
7 <sup>1</sup> / <sub>2</sub>	1 <sup>1</sup> / <sub>4</sub>	5 <sup>5</sup> / <sub>8</sub>	1,050	600	1,040	600	990	550	980	540	960	530
		3 <sup>3</sup> / <sub>4</sub>	1,480	810	1,470	800	1,390	730	1,370	720	1,350	710
		7 <sup>7</sup> / <sub>8</sub>	1,990	1,040	1,970	1,030	1,860	940	1,840	910	1,810	860
		1	2,580	1,250	2,550	1,210	2,410	1,010	2,390	980	2,350	940
9 <sup>1</sup> / <sub>2</sub>	1 <sup>1</sup> / <sub>4</sub>	3 <sup>3</sup> / <sub>4</sub>	1,480	810	1,470	800	1,390	730	1,370	720	1,350	710
		7 <sup>7</sup> / <sub>8</sub>	1,990	1,040	1,970	1,030	1,860	950	1,840	930	1,810	900
		1	2,580	1,310	2,550	1,290	2,410	1,180	2,390	1,160	2,350	1,140
11 <sup>1</sup> / <sub>2</sub>	1 <sup>1</sup> / <sub>4</sub>	7 <sup>7</sup> / <sub>8</sub>	1,990	1,040	1,970	1,030	1,860	950	1,840	930	1,810	900
		1	2,580	1,310	2,550	1,290	2,410	1,180	2,390	1,160	2,350	1,140
13 <sup>1</sup> / <sub>2</sub>	1 <sup>1</sup> / <sub>4</sub>	1	2,580	1,310	2,550	1,290	2,410	1,180	2,390	1,160	2,350	1,140

<sup>1</sup>Tabulated lateral design values ( $Z$ ) for bolted connections shall be multiplied by all applicable adjustment factors (see Table 23-III-A).

<sup>2</sup>Tabulated lateral design values ( $Z$ ) are for "full diameter" bolts with a bending yield strength ( $F_{yb}$ ) of 45,000 psi (310 N/mm<sup>2</sup>).

<sup>3</sup>Tabulated lateral design values ( $Z$ ) are based on a dowel-bearing strength ( $F_e$ ) of 58,000 psi (400 N/mm<sup>2</sup>) for ASTM A 36 steel.

**TABLE 23-III-L—BOLT DESIGN VALUES (Z) FOR SINGLE SHEAR (Two-member) CONNECTIONS<sup>1,2</sup>  
FOR GLUED-LAMINATED TIMBER MAIN MEMBER WITH SAWN LUMBER SIDE MEMBER OF IDENTICAL SPECIES**

THICKNESS		BOLT DIAM- ETER D inches	G = 0.55 SOUTHERN PINE			G = 0.50 DOUGLAS FIR-LARCH			G = 0.46 DOUGLAS FIR (S)			G = 0.43 HEM-FIR			G = 0.42 SPRUCE-PINE-FIR			G = 0.36 SPRUCE-PINE-FIR (S) WESTERN WOODS		
Main Member t <sub>m</sub> inches	Side Member t <sub>s</sub> inches		Z <sub>  </sub> lbs.	Z <sub>⊥</sub> lbs.	Z <sub>m⊥</sub> lbs.	Z <sub>  </sub> lbs.	Z <sub>⊥</sub> lbs.	Z <sub>m⊥</sub> lbs.	Z <sub>  </sub> lbs.	Z <sub>⊥</sub> lbs.	Z <sub>m⊥</sub> lbs.	Z <sub>  </sub> lbs.	Z <sub>⊥</sub> lbs.	Z <sub>m⊥</sub> lbs.	Z <sub>  </sub> lbs.	Z <sub>⊥</sub> lbs.	Z <sub>m⊥</sub> lbs.	Z <sub>  </sub> lbs.	Z <sub>⊥</sub> lbs.	Z <sub>m⊥</sub> lbs.
× 25.4 for mm			× 4.45 for N																	
2 1/2	1 1/2	1/2	—	—	—	610	370	370	580	340	330	550	320	310	540	320	300	490	280	240
		5/8	—	—	—	850	520	430	780	470	390	730	420	360	710	410	350	610	330	290
		3/4	—	—	—	1,020	590	500	940	520	450	870	460	410	850	450	400	740	360	330
		7/8	—	—	—	1,190	630	550	1,090	550	500	1,020	500	450	1,000	490	440	860	390	370
		1	—	—	—	1,360	680	610	1,250	600	550	1,160	500	500	1,140	530	490	980	420	410
3	1 1/2	1/2	660	400	470	—	—	—	—	—	—	—	—	—	—	—	—	—	—	—
		5/8	940	560	550	—	—	—	—	—	—	—	—	—	—	—	—	—	—	—
		3/4	1,270	660	620	—	—	—	—	—	—	—	—	—	—	—	—	—	—	—
		7/8	1,520	720	690	—	—	—	—	—	—	—	—	—	—	—	—	—	—	—
		1	1,740	770	750	—	—	—	—	—	—	—	—	—	—	—	—	—	—	—
3 1/8	1 1/2	1/2	—	—	—	610	370	430	580	340	390	550	320	360	540	320	340	490	280	280
		5/8	—	—	—	880	520	500	830	470	450	790	420	410	780	410	400	710	330	330
		3/4	—	—	—	1,200	590	570	1,130	520	510	1,060	460	460	1,040	450	450	890	360	370
		7/8	—	—	—	1,440	630	630	1,320	550	560	1,230	500	510	1,210	490	500	1,040	390	410
		1	—	—	—	1,640	680	690	1,510	600	620	1,410	540	560	1,380	530	550	1,190	420	450
5	1 1/2	5/8	940	560	640	—	—	—	—	—	—	—	—	—	—	—	—	—	—	—
		3/4	1,270	660	850	—	—	—	—	—	—	—	—	—	—	—	—	—	—	—
		7/8	1,680	720	1,020	—	—	—	—	—	—	—	—	—	—	—	—	—	—	—
		1	2,150	770	1,100	—	—	—	—	—	—	—	—	—	—	—	—	—	—	—
5 1/8	1 1/2	5/8	—	—	—	880	520	590	830	470	560	790	420	530	780	410	520	710	330	460
		3/4	—	—	—	1,200	590	790	1,140	520	740	1,100	460	670	1,080	450	660	990	360	530
		7/8	—	—	—	1,590	630	920	1,520	550	810	1,460	500	740	1,440	490	720	1,330	390	590
		1	—	—	—	2,050	680	990	1,930	600	890	1,800	540	810	1,760	530	780	1,520	420	640
6 3/4	1 1/2	5/8	940	560	640	880	520	590	830	470	560	790	420	530	780	410	520	710	330	460
		3/4	1,270	660	850	1,200	590	790	1,140	520	740	1,100	460	700	1,080	450	690	990	360	620
		7/8	1,680	720	1,090	1,590	630	1,010	1,520	550	950	1,460	500	900	1,440	490	890	1,330	390	750
		1	2,150	770	1,350	2,050	680	1,270	1,930	600	1,140	1,800	540	1,030	1,760	530	1,000	1,520	420	810

<sup>1</sup>Tabulated lateral design values (Z) for bolted connections shall be multiplied by all applicable adjustment factors (see Table 23-III-A).

<sup>2</sup>Tabulated lateral design values (Z) are for "full diameter" bolts with a bending yield strength ( $F_{yb}$ ) of 45,000 psi (310 N/mm<sup>2</sup>).

**TABLE 23-III-M—BOLT DESIGN VALUES (Z) FOR SINGLE SHEAR (Two-member)  
CONNECTIONS<sup>1,2,3</sup> FOR GLUED-LAMINATED TIMBER WITH 1/4-INCH (6.4 mm) ASTM A 36 STEEL SIDE PLATE**

THICKNESS		BOLT DIAMETER, D inches	G = 0.55 SOUTHERN PINE		G = 0.50 DOUGLAS FIR-LARCH		G = 0.46 DOUGLAS FIR (S)		G = 0.43 HEM-FIR		G = 0.42 SPRUCE-PINE-FIR		G = 0.36 SPRUCE-PINE-FIR (S) WESTERN WOODS	
Main Member <i>t<sub>m</sub></i> inches	Steel Side Plate <i>t<sub>s</sub></i> inches		Z <sub>  </sub> lbs.	Z <sub>⊥</sub> lbs.	Z <sub>  </sub> lbs.	Z <sub>⊥</sub> lbs.	Z <sub>  </sub> lbs.	Z <sub>⊥</sub> lbs.	Z <sub>  </sub> lbs.	Z <sub>⊥</sub> lbs.	Z <sub>  </sub> lbs.	Z <sub>⊥</sub> lbs.	Z <sub>  </sub> lbs.	Z <sub>⊥</sub> lbs.
× 25.4 for mm			× 4.45 for N											
2 1/2	1/4	1/2	—	—	750	390	730	350	700	320	690	310	600	260
		5/8	—	—	1,010	440	940	400	880	370	860	360	760	300
		3/4	—	—	1,210	490	1,120	450	1,050	410	1,030	400	910	330
		7/8	—	—	1,410	540	1,310	480	1,230	450	1,210	440	1,060	370
		1	—	—	1,620	590	1,500	530	1,410	490	1,380	480	1,210	400
3	1/4	1/2	780	500	—	—	—	—	—	—	—	—	—	—
		5/8	1,170	580	—	—	—	—	—	—	—	—	—	—
		3/4	1,560	640	—	—	—	—	—	—	—	—	—	—
		7/8	1,830	700	—	—	—	—	—	—	—	—	—	—
		1	2,090	750	—	—	—	—	—	—	—	—	—	—
3 1/8	1/4	1/2	—	—	750	470	730	420	710	390	700	370	660	310
		5/8	—	—	1,130	530	1,090	480	1,050	430	1,040	430	920	350
		3/4	—	—	1,490	590	1,380	530	1,290	480	1,270	470	1,100	390
		7/8	—	—	1,740	640	1,610	570	1,510	520	1,480	510	1,290	430
		1	—	—	1,990	690	1,840	630	1,720	570	1,690	560	1,470	460
5	1/4	5/8	1,170	710	—	—	—	—	—	—	—	—	—	—
		3/4	1,650	950	—	—	—	—	—	—	—	—	—	—
		7/8	2,220	1,110	—	—	—	—	—	—	—	—	—	—
		1	2,880	1,180	—	—	—	—	—	—	—	—	—	—
5 1/8	1/4	5/8	—	—	1,130	660	1,090	630	1,050	600	1,040	600	980	530
		3/4	—	—	1,580	900	1,530	820	1,480	740	1,470	720	1,370	590
		7/8	—	—	2,130	1,000	2,050	880	1,990	800	1,970	780	1,840	640
		1	—	—	2,760	1,070	2,660	960	2,580	870	2,550	850	2,350	690
6 3/4	1/4	5/8	1,170	710	1,130	660	1,090	630	1,050	600	1,040	600	980	540
		3/4	1,650	950	1,580	900	1,530	850	1,480	810	1,470	800	1,370	720
		7/8	2,220	1,240	2,130	1,160	2,050	1,090	1,990	1,040	1,970	1,010	1,840	830
		1	2,880	1,540	2,760	1,400	2,660	1,250	2,580	1,130	2,550	1,100	2,390	890

(Continued)

**TABLE 23-III-M—BOLT DESIGN VALUES (Z) FOR SINGLE SHEAR (Two-member)  
CONNECTIONS<sup>1,2,3</sup> FOR GLUED-LAMINATED TIMBER WITH 1/4-INCH (6.4 mm) ASTM A 36 STEEL SIDE PLATE—(Continued)**

8 <sup>1/2</sup>	1/4	3/4	1,650	950	—	—	—	—	—	—	—	—	—	—
		7/8	2,220	1,240	—	—	—	—	—	—	—	—	—	—
		1	2,880	1,540	—	—	—	—	—	—	—	—	—	—
8 <sup>3/4</sup>	1/4	3/4	—	—	1,580	900	1,530	850	1,480	810	1,470	800	1,370	720
		7/8	—	—	2,130	1,160	2,050	1,090	1,990	1,040	1,970	1,030	1,840	930
		1	—	—	2,760	1,460	2,660	1,380	2,580	1,310	2,550	1,290	2,390	1,130
10 <sup>1/2</sup>	1/4	7/8	2,220	1,240	—	—	—	—	—	—	—	—	—	—
		1	2,880	1,540	—	—	—	—	—	—	—	—	—	—
		7/8	—	—	2,130	1,160	2,050	1,090	1,990	1,040	1,970	1,030	1,840	930
10 <sup>3/4</sup>	1/4	1	—	—	2,760	1,460	2,660	1,380	2,580	1,310	2,550	1,290	2,390	1,160
		7/8	—	—	2,130	1,160	2,050	1,090	1,990	1,040	1,970	1,030	1,840	930
		1	—	—	2,760	1,460	2,660	1,380	2,580	1,310	2,550	1,290	2,390	1,160
12 <sup>1/4</sup>	1/4	7/8	—	—	2,130	1,160	2,050	1,090	1,990	1,040	1,970	1,030	1,840	930
		1	—	—	2,760	1,460	2,660	1,380	2,580	1,310	2,550	1,290	2,390	1,160
		1	—	—	2,760	1,460	2,660	1,380	2,580	1,310	2,550	1,290	2,390	1,160
14 <sup>1/4</sup>	1/4	1	—	—	2,760	1,460	2,660	1,380	2,580	1,310	2,550	1,290	2,390	1,160
		7/8	—	—	2,130	1,160	2,050	1,090	1,990	1,040	1,970	1,030	1,840	930
		1	—	—	2,760	1,460	2,660	1,380	2,580	1,310	2,550	1,290	2,390	1,160

<sup>1</sup>Tabulated lateral design values (Z) for bolted connections shall be multiplied by all applicable adjustment factors (see Table 23-III-A).

<sup>2</sup>Tabulated lateral design values (Z) are for “full diameter” bolts with a bending yield strength ( $F_{yb}$ ) of 45,000 psi (310 N/mm<sup>2</sup>).

<sup>3</sup>Tabulated lateral design values (Z) are based on a dowel-bearing strength ( $F_e$ ) of 58,000 psi (400 N/mm<sup>2</sup>) for ASTM A 36 steel.

**TABLE 23-III-N—BOLT DESIGN VALUES (Z) FOR DOUBLE SHEAR (Three-member) CONNECTIONS<sup>1,2</sup>  
FOR SAWN LUMBER WITH ALL MEMBERS OF IDENTICAL SPECIES**

THICKNESS		BOLT DIAME- TER, D inches	G = 0.67 RED OAK			G = 0.55 MIXED MAPLE			G = 0.50 DOUGLAS FIR-LARCH			G = 0.49 DOUGLAS FIR-LARCH (N)			G = 0.46 DOUGLAS FIR (S) HEM-FIR (N)		
Main Mem- ber, t <sub>m</sub> inches	Side Mem- ber, t <sub>s</sub> inches		Z <sub>  </sub> lbs.	Z <sub>⊥</sub> lbs.	Z <sub>m⊥</sub> lbs.	Z <sub>  </sub> lbs.	Z <sub>⊥</sub> lbs.	Z <sub>m⊥</sub> lbs.	Z <sub>  </sub> lbs.	Z <sub>⊥</sub> lbs.	Z <sub>m⊥</sub> lbs.	Z <sub>  </sub> lbs.	Z <sub>⊥</sub> lbs.	Z <sub>m⊥</sub> lbs.	Z <sub>  </sub> lbs.	Z <sub>⊥</sub> lbs.	Z <sub>m⊥</sub> lbs.
× 25.4 for mm			× 4.45 for N														
1 1/2	1 1/2	1/2	1,410	960	730	1,150	800	550	1,050	730	470	1,030	720	460	970	680	420
		5/8	1,760	1,310	810	1,440	1,130	610	1,310	1,040	530	1,290	1,030	520	1,210	940	470
		3/4	2,110	1,690	890	1,730	1,330	660	1,580	1,170	590	1,550	1,130	560	1,450	1,040	520
		7/8	2,460	1,920	960	2,020	1,440	720	1,840	1,260	630	1,800	1,210	600	1,690	1,100	550
		1	2,810	2,040	1,020	2,310	1,530	770	2,100	1,350	680	2,060	1,290	650	1,930	1,200	600
2 1/2	1 1/2	1/2	1,530	960	1,120	1,320	800	910	1,230	730	790	1,210	720	760	1,160	680	700
		5/8	2,150	1,310	1,340	1,870	1,130	1,020	1,760	1,040	880	1,740	1,030	860	1,660	940	780
		3/4	2,890	1,770	1,480	2,550	1,330	1,110	2,400	1,170	980	2,380	1,130	940	2,280	1,040	860
		7/8	3,780	1,920	1,600	3,360	1,440	1,200	3,060	1,260	1,050	3,010	1,210	1,010	2,820	1,100	920
		1	4,690	2,040	1,700	3,840	1,530	1,280	3,500	1,350	1,130	3,440	1,290	1,080	3,220	1,200	1,000
3	1 1/2	1/2	1,530	960	1,120	1,320	800	940	1,230	730	860	1,210	720	850	1,160	680	810
		5/8	2,150	1,310	1,510	1,870	1,130	1,220	1,760	1,040	1,050	1,740	1,030	1,030	1,660	940	940
		3/4	2,890	1,770	1,780	2,550	1,330	1,330	2,400	1,170	1,170	2,380	1,130	1,130	2,280	1,040	1,040
		7/8	3,780	1,920	1,920	3,360	1,440	1,440	3,180	1,260	1,260	3,150	1,210	1,210	3,030	1,100	1,100
		1	4,820	2,040	2,040	4,310	1,530	1,530	4,090	1,350	1,350	4,050	1,290	1,290	3,860	1,200	1,200
3 1/2	1 1/2	1/2	1,530	960	1,120	1,320	800	940	1,230	730	860	1,210	720	850	1,160	680	810
		5/8	2,150	1,310	1,510	1,870	1,130	1,290	1,760	1,040	1,190	1,740	1,030	1,170	1,660	940	1,090
		3/4	2,890	1,770	1,980	2,550	1,330	1,550	2,400	1,170	1,370	2,380	1,130	1,310	2,280	1,040	1,210
		7/8	3,780	1,920	2,240	3,360	1,440	1,680	3,180	1,260	1,470	3,150	1,210	1,410	3,030	1,100	1,290
		1	4,820	2,040	2,380	4,310	1,530	1,790	4,090	1,350	1,580	4,050	1,290	1,510	3,860	1,200	1,400
	3 1/2	1/2	1,660	1,180	1,180	1,500	1,040	1,040	1,430	970	970	1,420	960	960	1,370	920	920
		5/8	2,590	1,770	1,770	2,340	1,560	1,420	2,240	1,410	1,230	2,220	1,390	1,200	2,150	1,290	1,090
		3/4	3,730	2,380	2,070	3,380	1,910	1,550	3,220	1,750	1,370	3,190	1,700	1,310	3,090	1,610	1,210
		7/8	5,080	2,820	2,240	4,600	2,330	1,680	4,290	2,130	1,470	4,210	2,070	1,410	3,940	1,960	1,290
		1	6,560	3,340	2,380	5,380	2,780	1,790	4,900	2,580	1,580	4,810	2,520	1,510	4,510	2,410	1,400

(Continued)

TABLE 23-III-N—BOLT DESIGN VALUES (Z) FOR DOUBLE SHEAR (Three-member) CONNECTIONS<sup>1,2</sup>  
FOR SAWN LUMBER WITH ALL MEMBERS OF IDENTICAL SPECIES—(Continued)

THICKNESS		BOLT DIAME- TER, D inches	G = 0.67 RED OAK			G = 0.55 MIXED MAPLE			G = 0.50 DOUGLAS FIR-LARCH			G = 0.49 DOUGLAS FIR-LARCH (N)			G = 0.46 DOUGLAS FIR (S) HEM-FIR (N)		
Main Member, $t_m$ inches	Side Member, $t_s$ inches		$Z_{  }$ lbs.	$Z_{\perp}$ lbs.	$Z_{m\perp}$ lbs.	$Z_{  }$ lbs.	$Z_{\perp}$ lbs.	$Z_{m\perp}$ lbs.	$Z_{  }$ lbs.	$Z_{\perp}$ lbs.	$Z_{m\perp}$ lbs.	$Z_{  }$ lbs.	$Z_{\perp}$ lbs.	$Z_{m\perp}$ lbs.	$Z_{  }$ lbs.	$Z_{\perp}$ lbs.	$Z_{m\perp}$ lbs.
× 25.4 for mm			× 4.45 for N														
4 1/2	1 1/2	5/8	2,150	1,310	1,510	1,870	1,130	1,290	1,760	1,040	1,190	1,740	1,030	1,170	1,660	940	1,110
		3/4	2,890	1,770	1,980	2,550	1,330	1,690	2,400	1,170	1,580	2,380	1,130	1,550	2,280	1,040	1,480
		7/8	3,780	1,920	2,520	3,360	1,440	2,170	3,180	1,260	1,890	3,150	1,210	1,810	3,030	1,100	1,650
		1	4,820	2,040	3,060	4,310	1,530	2,300	4,090	1,350	2,030	4,050	1,290	1,940	3,860	1,200	1,800
	3 1/2	5/8	2,590	1,770	1,770	2,340	1,560	1,560	2,240	1,410	1,460	2,220	1,390	1,450	2,150	1,290	1,390
		3/4	3,730	2,380	2,480	3,380	1,910	1,990	3,220	1,750	1,760	3,190	1,700	1,690	3,090	1,610	1,550
		7/8	5,080	2,820	2,870	4,600	2,330	2,170	4,390	2,130	1,890	4,350	2,070	1,810	4,130	1,960	1,650
		1	6,630	3,340	3,060	5,740	2,780	2,300	5,330	2,580	2,030	5,250	2,520	1,940	4,990	2,410	1,800
5 1/2	1 1/2	5/8	2,150	1,310	1,510	1,870	1,130	1,290	1,760	1,040	1,190	1,740	1,030	1,170	1,660	940	1,110
		3/4	2,890	1,770	1,980	2,550	1,330	1,690	2,400	1,170	1,580	2,380	1,130	1,550	2,280	1,040	1,480
		7/8	3,780	1,920	2,520	3,360	1,440	2,170	3,180	1,260	2,030	3,150	1,210	1,990	3,030	1,100	1,900
		1	4,820	2,040	3,120	4,310	1,530	2,700	4,090	1,350	2,480	4,050	1,290	2,370	3,860	1,200	2,200
	3 1/2	5/8	2,590	1,770	1,770	2,340	1,560	1,560	2,240	1,410	1,460	2,220	1,390	1,450	2,150	1,290	1,390
		3/4	3,730	2,380	2,480	3,380	1,910	2,180	3,220	1,750	2,050	3,190	1,700	2,020	3,090	1,610	1,900
		7/8	5,080	2,820	3,290	4,600	2,330	2,650	4,390	2,130	2,310	4,350	2,070	2,210	4,130	1,960	2,020
		1	6,630	3,340	3,740	5,740	2,780	2,810	5,330	2,580	2,480	5,250	2,520	2,370	4,990	2,410	2,200
7 1/2	1 1/2	5/8	2,150	1,310	1,510	1,870	1,130	1,290	1,760	1,040	1,190	1,740	1,030	1,170	1,660	940	1,110
		3/4	2,890	1,770	1,980	2,550	1,330	1,690	2,400	1,170	1,580	2,380	1,130	1,550	2,280	1,040	1,480
		7/8	3,780	1,920	2,520	3,360	1,440	2,170	3,180	1,260	2,030	3,150	1,210	1,990	3,030	1,100	1,900
		1	4,820	2,040	3,120	4,310	1,530	2,700	4,090	1,350	2,530	4,050	1,290	2,480	3,860	1,200	2,390
	3 1/2	5/8	2,590	1,770	1,770	2,340	1,560	1,560	2,240	1,410	1,460	2,220	1,390	1,450	2,150	1,290	1,390
		3/4	3,730	2,380	2,480	3,380	1,910	2,180	3,220	1,750	2,050	3,190	1,700	2,020	3,090	1,610	1,940
		7/8	5,080	2,820	3,290	4,600	2,330	2,890	4,390	2,130	2,720	4,350	2,070	2,670	4,130	1,960	2,560
		1	6,630	3,340	4,190	5,740	2,780	3,680	5,330	2,580	3,380	5,250	2,520	3,230	4,990	2,410	3,000

<sup>1</sup>Tabulated lateral design values (Z) for bolted connections shall be multiplied by all applicable adjustment factors (see Table 23-III-A).

<sup>2</sup>Tabulated lateral design values (Z) are for "full diameter" bolts with a bending yield strength ( $F_{yb}$ ) of 45,000 psi (310 N/mm<sup>2</sup>).

THICKNESS		BOLT DIAMETER, D Inches	G = 0.43 HEM-FIR			G = 0.42 SPRUCE-PINE-FIR			G = 0.37 REDWOOD (open grain)			G = 0.36 EASTERN SOFTWOODS SPRUCE-PINE-FIR(S) WESTERN CEDARS WESTERN WOODS			G = 0.35 NORTHERN SPECIES			
Main Member, 1/4 inches	Side Member, 1/4 inches		Z <sub>  </sub> lbs.	Z <sub>⊥</sub> lbs.	Z <sub>m⊥</sub> lbs.	Z <sub>  </sub> lbs.	Z <sub>⊥</sub> lbs.	Z <sub>m⊥</sub> lbs.	Z <sub>  </sub> lbs.	Z <sub>⊥</sub> lbs.	Z <sub>m⊥</sub> lbs.	Z <sub>  </sub> lbs.	Z <sub>⊥</sub> lbs.	Z <sub>m⊥</sub> lbs.	Z <sub>  </sub> lbs.	Z <sub>⊥</sub> lbs.	Z <sub>m⊥</sub> lbs.	
× 25.4 for mm			× 4.45 for N															
1 1/2	1 1/2	1/2	900	650	380	880	640	370	780	580	310	760	560	290	730	550	290	
		5/8	1,130	840	420	1,100	830	410	970	690	350	950	660	330	910	640	320	
		3/4	1,350	920	460	1,320	900	450	1,170	740	370	1,140	720	360	1,100	700	350	
		7/8	1,580	1,000	500	1,540	970	490	1,360	810	410	1,330	790	390	1,280	740	370	
		1	1,800	1,080	540	1,760	1,050	530	1,560	870	440	1,520	840	420	1,460	810	410	
2 1/2	1 1/2	1/2	1,100	650	640	1,080	640	610	990	580	510	980	560	490	950	550	480	
		5/8	1,590	840	700	1,570	830	690	1,450	690	580	1,430	660	550	1,390	640	530	
		3/4	2,190	920	770	2,160	900	750	1,950	740	620	1,900	720	600	1,830	700	580	
		7/8	2,630	1,000	830	2,570	970	810	2,270	810	680	2,210	790	660	2,130	740	610	
		1	3,000	1,080	900	2,940	1,050	880	2,590	870	730	2,530	840	700	2,440	810	680	
3	1 1/2	1/2	1,100	650	760	1,080	640	740	990	580	620	980	560	590	950	550	570	
		5/8	1,590	840	840	1,570	830	830	1,450	690	690	1,430	660	660	1,390	640	640	
		3/4	2,190	920	920	2,160	900	900	2,010	740	740	1,990	720	720	1,940	700	700	
		7/8	2,920	1,000	1,000	2,880	970	970	2,690	810	810	2,660	790	790	2,560	740	740	
		1	3,600	1,080	1,080	3,530	1,050	1,050	3,110	870	870	3,040	840	840	2,930	810	810	
3 1/2	1 1/2	1/2	1,100	650	760	1,080	640	740	990	580	670	980	560	660	950	550	640	
		5/8	1,590	840	980	1,570	830	960	1,450	690	810	1,430	660	770	1,390	640	740	
		3/4	2,190	920	1,080	2,160	900	1,050	2,010	740	870	1,990	720	840	1,940	700	810	
		7/8	2,920	1,000	1,160	2,880	970	1,130	2,690	810	950	2,660	790	920	2,560	740	860	
		1	3,600	1,080	1,260	3,530	1,050	1,230	3,110	870	1,020	3,040	840	980	2,930	810	950	
	3 1/2	3 1/2	1/2	1,330	880	880	1,310	870	860	1,230	800	720	1,220	780	680	1,200	760	670
			5/8	2,070	1,190	980	2,050	1,170	960	1,930	1,030	810	1,900	1,000	770	1,870	970	740
			3/4	2,980	1,490	1,080	2,950	1,460	1,050	2,720	1,290	870	2,660	1,270	840	2,560	1,240	810
			7/8	3,680	1,840	1,160	3,600	1,810	1,130	3,180	1,640	950	3,100	1,610	920	2,990	1,550	860
			1	4,200	2,280	1,260	4,110	2,240	1,230	3,630	2,030	1,020	3,540	1,960	980	3,410	1,890	950

1994 UNIFORM BUILDING CODE

23-II-N

(Continued)

**TABLE 23-III-N—BOLT DESIGN VALUES (Z) FOR DOUBLE SHEAR (Three-member) CONNECTIONS<sup>1,2</sup> FOR SAWN LUMBER WITH ALL MEMBERS OF IDENTICAL SPECIES—(Continued)**

THICKNESS		BOLT DIAMETER, D inches	G = 0.43 HEM-FIR			G = 0.42 SPRUCE-PINE-FIR			G = 0.37 REDWOOD (open grain)			G = 0.36 EASTERN SOFTWOODS SPRUCE-PINE-FIR(S) WESTERN CEDARS WESTERN WOODS			G = 0.35 NORTHERN SPECIES		
Main Member, t <sub>m</sub> inches	Side Member, t <sub>s</sub> inches		Z <sub>  </sub> lbs.	Z <sub>⊥</sub> lbs.	Z <sub>m⊥</sub> lbs.	Z <sub>  </sub> lbs.	Z <sub>⊥</sub> lbs.	Z <sub>m⊥</sub> lbs.	Z <sub>  </sub> lbs.	Z <sub>⊥</sub> lbs.	Z <sub>m⊥</sub> lbs.	Z <sub>  </sub> lbs.	Z <sub>⊥</sub> lbs.	Z <sub>m⊥</sub> lbs.	Z <sub>  </sub> lbs.	Z <sub>⊥</sub> lbs.	Z <sub>m⊥</sub> lbs.
× 25.4 for mm			× 4.45 for N														
4 1/2	1 1/2	5/8	1,590	840	1,050	1,570	830	1,040	1,450	690	940	1,430	660	920	1,390	640	900
		3/4	2,190	920	1,380	2,160	900	1,350	2,010	740	1,110	1,990	720	1,080	1,940	700	1,050
		7/8	2,920	1,000	1,500	2,880	970	1,460	2,690	810	1,220	2,660	790	1,180	2,560	740	1,100
		1	3,600	1,080	1,620	3,530	1,050	1,580	3,110	870	1,310	3,040	840	1,260	2,930	810	1,220
	3 1/2	5/8	2,070	1,190	1,270	2,050	1,170	1,240	1,930	1,030	1,040	1,900	1,000	980	1,870	970	960
		3/4	2,980	1,490	1,380	2,950	1,460	1,350	2,770	1,290	1,110	2,740	1,270	1,080	2,660	1,240	1,050
		7/8	3,900	1,840	1,500	3,840	1,810	1,460	3,480	1,640	1,220	3,410	1,610	1,180	3,320	1,550	1,100
		1	4,730	2,280	1,620	4,660	2,240	1,580	4,240	2,030	1,310	4,170	1,960	1,260	4,050	1,890	1,220
5 1/2	1 1/2	5/8	1,590	840	1,050	1,570	830	1,040	1,450	690	940	1,430	660	920	1,390	640	900
		3/4	2,190	920	1,400	2,160	900	1,380	2,010	740	1,250	1,990	720	1,230	1,940	700	1,210
		7/8	2,920	1,000	1,800	2,880	970	1,780	2,690	810	1,490	2,660	790	1,440	2,560	740	1,350
		1	3,600	1,080	1,980	3,530	1,050	1,930	3,110	870	1,600	3,040	840	1,540	2,930	810	1,490
	3 1/2	5/8	2,070	1,190	1,320	2,050	1,170	1,310	1,930	1,030	1,210	1,900	1,000	1,180	1,870	970	1,160
		3/4	2,980	1,490	1,690	2,950	1,460	1,650	2,770	1,290	1,360	2,740	1,270	1,320	2,660	1,240	1,280
		7/8	3,900	1,840	1,830	3,840	1,810	1,780	3,480	1,640	1,490	3,410	1,610	1,440	3,320	1,550	1,350
		1	4,730	2,280	1,980	4,660	2,240	1,930	4,240	2,030	1,600	4,170	1,960	1,540	4,050	1,890	1,490
7 1/2	1 1/2	5/8	1,590	840	1,050	1,570	830	1,040	1,450	690	940	1,430	660	920	1,390	640	900
		3/4	2,190	920	1,400	2,160	900	1,380	2,010	740	1,250	1,990	720	1,230	1,940	700	1,210
		7/8	2,920	1,000	1,800	2,880	970	1,780	2,690	810	1,630	2,660	790	1,600	2,560	740	1,550
		1	3,600	1,080	2,270	3,530	1,050	2,240	3,110	870	2,040	3,040	840	2,010	2,930	810	1,970
	3 1/2	5/8	2,070	1,190	1,320	2,050	1,170	1,310	1,930	1,030	1,210	1,900	1,000	1,180	1,870	970	1,160
		3/4	2,980	1,490	1,850	2,950	1,460	1,820	2,770	1,290	1,670	2,740	1,270	1,650	2,660	1,240	1,620
		7/8	3,900	1,840	2,450	3,840	1,810	2,420	3,480	1,640	2,030	3,410	1,610	1,970	3,320	1,550	1,840
		1	4,730	2,280	2,700	4,660	2,240	2,630	4,240	2,030	2,180	4,170	1,960	2,100	4,050	1,890	2,030

<sup>1</sup>Tabulated lateral design values (Z) for bolted connections shall be multiplied by all applicable adjustment factors (see Table 23-III-A).

<sup>2</sup>Tabulated lateral design values (Z) are for "full diameter" bolts with a bending yield strength (F<sub>y,b</sub>) of 45,000 psi (310 N/mm<sup>2</sup>).

**TABLE 23-III-O—BOLT DESIGN VALUES (Z) FOR DOUBLE SHEAR (Three-member) CONNECTIONS<sup>1,2,3</sup>  
FOR SAWN LUMBER WITH 1/4-INCH (6.4 mm) ASTM A 36 STEEL SIDE PLATE**

THICKNESS		BOLT DIAMETER D inches	G = 0.67 RED OAK		G = 0.55 MIXED MAPLE SOUTHERN PINE		G = 0.50 DOUGLAS FIR- LARCH		G = 0.49 DOUGLAS FIR- LARCH (N)		G = 0.46 DOUGLAS FIR (S) HEM-FIR (N)	
Main Member t <sub>m</sub> inches	Steel Side Plate t <sub>s</sub> inches		Z <sub>  </sub> inches	Z <sub>⊥</sub> inches	Z <sub>  </sub> inches	Z <sub>⊥</sub> inches	Z <sub>  </sub> inches	Z <sub>⊥</sub> inches	Z <sub>  </sub> inches	Z <sub>⊥</sub> inches	Z <sub>  </sub> inches	Z <sub>⊥</sub> inches
× 25.4 for mm			× 4.45 for N									
1 1/2	1/4	1/2	1,410	730	1,150	550	1,050	470	1,030	460	970	420
		5/8	1,760	810	1,440	610	1,310	530	1,290	520	1,210	470
		3/4	2,110	890	1,730	660	1,580	590	1,550	560	1,450	520
		7/8	2,460	960	2,020	720	1,840	630	1,800	600	1,690	550
		1	2,810	1,020	2,310	770	2,100	680	2,060	650	1,930	600
2 1/2	1/4	1/2	1,700	1,130	1,570	910	1,510	790	1,500	760	1,460	700
		5/8	2,550	1,340	2,350	1,020	2,190	880	2,150	860	2,010	780
		3/4	3,520	1,480	2,880	1,110	2,630	980	2,580	940	2,410	860
		7/8	4,100	1,600	3,360	1,200	3,060	1,050	3,010	1,010	2,820	920
		1	4,690	1,700	3,840	1,280	3,500	1,130	3,440	1,080	3,220	1,000
3	1/4	1/2	1,700	1,130	1,570	1,000	1,510	940	1,500	920	1,460	840
		5/8	2,550	1,610	2,350	1,220	2,250	1,050	2,240	1,030	2,170	940
		3/4	3,590	1,780	3,300	1,330	3,150	1,170	3,090	1,130	2,900	1,040
		7/8	4,830	1,920	4,040	1,440	3,680	1,260	3,610	1,210	3,380	1,100
		1	5,630	2,040	4,610	1,530	4,200	1,350	4,130	1,290	3,860	1,200
3 1/2	1/4	1/2	1,700	1,130	1,570	1,000	1,510	940	1,500	930	1,460	890
		5/8	2,550	1,610	2,350	1,420	2,250	1,230	2,240	1,200	2,170	1,090
		3/4	3,590	2,070	3,300	1,550	3,170	1,370	3,150	1,310	3,060	1,210
		7/8	4,830	2,240	4,440	1,680	4,260	1,470	4,210	1,410	3,940	1,290
		1	6,270	2,380	5,380	1,790	4,900	1,580	4,810	1,510	4,510	1,400
4 1/2	1/4	5/8	2,550	1,610	2,350	1,420	2,250	1,330	2,240	1,320	2,170	1,260
		3/4	3,590	2,170	3,300	1,910	3,170	1,760	3,150	1,690	3,060	1,550
		7/8	4,830	2,810	4,440	2,170	4,260	1,890	4,220	1,810	4,100	1,650
		1	6,270	3,060	5,750	2,300	5,520	2,030	5,480	1,940	5,320	1,800

(Continued)

1994 UNIFORM BUILDING CODE

23-III-O

2-1015

TABLE 23-III-O—BOLT DESIGN VALUES (Z) FOR DOUBLE SHEAR (Three-member) CONNECTIONS<sup>1,2,3</sup>  
FOR SAWN LUMBER WITH 1/4-INCH (6.4 mm) ASTM A 36 STEEL SIDE PLATE—(Continued)

THICKNESS		BOLT DIAMETER D Inches	G = 0.67 RED OAK		G = 0.55 MIXED MAPLE SOUTHERN PINE		G = 0.50 DOUGLAS FIR- LARCH		G = 0.49 DOUGLAS FIR- LARCH (N)		G = 0.46 DOUGLAS FIR (S) HEM-FIR (N)	
Main Member $t_m$ Inches	Steel Side Plate $t_s$ Inches		$Z_{  }$ Inches	$Z_{\perp}$ Inches	$Z_{  }$ Inches	$Z_{\perp}$ Inches	$Z_{  }$ Inches	$Z_{\perp}$ Inches	$Z_{  }$ Inches	$Z_{\perp}$ Inches	$Z_{  }$ Inches	$Z_{\perp}$ Inches
× 25.4 for mm			× 4.45 for N									
5 1/2	1/4	5/8	2,550	1,610	2,350	1,420	2,250	1,330	2,240	1,320	2,170	1,260
		3/4	3,590	2,170	3,300	1,910	3,170	1,800	3,150	1,770	3,060	1,700
		7/8	4,830	2,810	4,440	2,470	4,260	2,310	4,220	2,210	4,100	2,020
		1	6,270	3,530	5,750	2,810	5,520	2,480	5,480	2,370	5,320	2,200
7 1/2	1/4	5/8	2,550	1,610	2,350	1,420	2,250	1,330	2,240	1,320	2,170	1,260
		3/4	3,590	2,170	3,300	1,910	3,170	1,800	3,150	1,770	3,060	1,700
		7/8	4,830	2,810	4,440	2,470	4,260	2,320	4,220	2,280	4,100	2,180
		1	6,270	3,530	5,750	3,090	5,520	2,910	5,480	2,850	5,320	2,750
9 1/2	1/4	3/4	3,590	2,170	3,300	1,910	3,170	1,800	3,150	1,770	3,060	1,700
		7/8	4,830	2,810	4,440	2,470	4,260	2,320	4,220	2,280	4,100	2,180
		1	6,270	3,530	5,750	3,090	5,520	2,910	5,480	2,850	5,320	2,750
11 1/2	1/4	7/8	4,830	2,810	4,440	2,470	4,260	2,320	4,220	2,280	4,100	2,180
		1	6,270	3,530	5,750	3,090	5,520	2,910	5,480	2,850	5,320	2,750
13 1/2	1/4	1	6,270	3,530	5,750	3,090	5,520	2,910	5,480	2,850	5,320	2,750

<sup>1</sup>Tabulated lateral design values (Z) for bolted connections shall be multiplied by all applicable adjustment factors (see Table 23-III-A).

<sup>2</sup>Tabulated lateral design values (Z) are for "full diameter" bolts with a bending yield strength ( $F_{yb}$ ) of 45,000 psi (310 N/mm<sup>2</sup>).

<sup>3</sup>Tabulated lateral design values (Z) are based on a dowel-bearing strength ( $F_e$ ) of 58,000 psi (400 N/mm<sup>2</sup>) for ASTM A 36 steel.

THICKNESS		BOLT DIAMETER D inches	G = 0.43 HEM-FIR		G = 0.42 SPRUCE-PINE-FIR		G = 0.37 REDWOOD (open grain)		G = 0.36 EASTERN SOFTWOODS SPRUCE-PINE-FIR(S) WESTERN CEDARS WESTERN WOODS		G = 0.35 NORTHERN SPECIES	
Main Member $t_m$ inches	Steel Side Plate $t_s$ inches		$Z_{  }$ inches	$Z_{\perp}$ inches	$Z_{  }$ inches	$Z_{\perp}$ inches	$Z_{  }$ inches	$Z_{\perp}$ inches	$Z_{  }$ inches	$Z_{\perp}$ inches	$Z_{  }$ inches	$Z_{\perp}$ inches
× 25.4 for mm			× 4.45 for N									
1 <sup>1/2</sup>	1/4	1/2	900	380	880	370	780	310	760	290	730	290
		5/8	1,130	420	1,100	410	970	350	950	330	910	320
		3/4	1,350	460	1,320	450	1,170	370	1,140	360	1,100	350
		7/8	1,580	500	1,540	490	1,360	410	1,330	390	1,280	370
		1	1,800	540	1,760	530	1,560	440	1,520	420	1,460	410
2 <sup>1/2</sup>	1/4	1/2	1,410	640	1,400	610	1,300	510	1,270	490	1,220	480
		5/8	1,880	700	1,840	690	1,620	580	1,580	550	1,520	530
		3/4	2,250	770	2,200	750	1,950	620	1,900	600	1,830	580
		7/8	2,630	830	2,570	810	2,270	680	2,210	660	2,130	610
		1	3,000	900	2,940	880	2,590	730	2,530	700	2,440	680
3	1/4	1/2	1,410	770	1,400	740	1,330	620	1,310	590	1,290	570
		5/8	2,110	840	2,090	830	1,950	690	1,900	660	1,830	640
		3/4	2,700	920	2,640	900	2,330	740	2,280	720	2,190	700
		7/8	3,150	1,000	3,080	970	2,720	810	2,660	790	2,560	740
		1	3,600	1,080	3,530	1,050	3,110	870	3,040	840	2,930	810
3 <sup>1/2</sup>	1/4	1/2	1,410	860	1,400	840	1,330	720	1,310	680	1,290	670
		5/8	2,110	980	2,090	960	1,980	810	1,960	770	1,930	740
		3/4	2,960	1,080	2,940	1,050	2,720	870	2,660	840	2,560	810
		7/8	3,680	1,160	3,600	1,130	3,180	950	3,100	920	2,990	860
		1	4,200	1,260	4,110	1,230	3,630	1,020	3,540	980	3,410	950

(Continued)

TABLE 23-III-O—BOLT DESIGN VALUES (Z) FOR DOUBLE SHEAR (Three-member) CONNECTIONS<sup>1,2,3</sup>  
FOR SAWN LUMBER WITH 1/4-INCH (6.4 mm) ASTM A 36 STEEL SIDE PLATE—(Continued)

THICKNESS		BOLT DIAMETER D inches	G = 0.43 HEM-FIR		G = 0.42 SPRUCE-PINE-FIR		G = 0.37 REDWOOD (open grain)		G = 0.36 EASTERN SOFTWOODS SPRUCE-PINE-FIR(S) WESTERN CEDARS WESTERN WOODS		G = 0.35 NORTHERN SPECIES	
Main Member t <sub>m</sub> inches	Steel Side Plate t <sub>s</sub> inches		Z <sub>  </sub> inches	Z <sub>⊥</sub> inches	Z <sub>  </sub> inches	Z <sub>⊥</sub> inches	Z <sub>  </sub> inches	Z <sub>⊥</sub> inches	Z <sub>  </sub> inches	Z <sub>⊥</sub> inches	Z <sub>  </sub> inches	Z <sub>⊥</sub> inches
× 25.4 for mm			× 4.45 for N									
4 1/2	1/4	5/8	2,110	1,200	2,090	1,190	1,980	1,040	1,960	980	1,930	960
		3/4	2,960	1,380	2,940	1,350	2,780	1,110	2,750	1,080	2,700	1,050
		7/8	3,980	1,500	3,940	1,460	3,730	1,220	3,690	1,180	3,620	1,100
		1	5,150	1,620	5,110	1,580	4,670	1,310	4,560	1,260	4,390	1,220
5 1/2	1/4	5/8	2,110	1,200	2,090	1,190	1,980	1,100	1,960	1,070	1,930	1,060
		3/4	2,960	1,610	2,940	1,590	2,780	1,360	2,750	1,320	2,700	1,280
		7/8	3,980	1,830	3,940	1,780	3,730	1,490	3,690	1,440	3,620	1,350
		1	5,150	1,980	5,110	1,930	4,830	1,600	4,770	1,540	4,690	1,490
7 1/2	1/4	5/8	2,110	1,200	2,090	1,190	1,980	1,100	1,960	1,070	1,930	1,060
		3/4	2,960	1,610	2,940	1,590	2,780	1,460	2,750	1,440	2,700	1,410
		7/8	3,980	2,080	3,940	2,060	3,730	1,890	3,690	1,860	3,620	1,800
		1	5,150	2,620	5,110	2,590	4,830	2,180	4,770	2,100	4,690	2,030
9 1/2	1/4	3/4	2,960	1,610	2,940	1,590	2,780	1,460	2,750	1,440	2,700	1,410
		7/8	3,980	2,080	3,940	2,060	3,730	1,890	3,690	1,860	3,620	1,800
		1	5,150	2,620	5,110	2,590	4,830	2,370	4,770	2,330	4,690	2,290
11 1/2	1/4	7/8	3,980	2,080	3,940	2,060	3,730	1,890	3,690	1,860	3,620	1,800
		1	5,150	2,620	5,110	2,590	4,830	2,370	4,770	2,330	4,690	2,290
13 1/2	1/4	1	5,150	2,620	5,110	2,590	4,830	2,370	4,770	2,330	4,690	2,290

<sup>1</sup>Tabulated lateral design values (Z) for bolted connections shall be multiplied by all applicable adjustment factors (see Table 23-III-A).

<sup>2</sup>Tabulated lateral design values (Z) are for "full diameter" bolts with a bending yield strength ( $F_{y,b}$ ) of 45,000 psi (310 N/mm<sup>2</sup>).

<sup>3</sup>Tabulated lateral design values (Z) are based on a dowel-bearing strength ( $F_e$ ) of 58,000 psi (400 N/m<sup>2</sup>) for ASTM A 36 steel.

**TABLE 23-III-P—BOLT DESIGN VALUES (Z) FOR DOUBLE SHEAR (Three-member) CONNECTIONS<sup>1,2</sup> FOR GLUED-LAMINATED TIMBER MAIN MEMBER WITH SAWN LUMBER SIDE MEMBERS OF IDENTICAL SPECIES**

THICKNESS		BOLT DIAMETER, D, inches	G = 0.55 SOUTHERN PINE			G = 0.50 DOUGLAS FIR-LARCH			G = 0.46 DOUGLAS FIR (S)			G = 0.43 HEM-FIR			G = 0.42 SPRUCE-PINE-FIR			G = 0.36 SPRUCE-PINE-FIR (S) WESTERN WOODS		
Main Member $t_m$ inches	Side Member $t_s$ inches		$Z_{  }$ lbs.	$Z_{\perp}$ lbs.	$Z_{m\perp}$ lbs.	$Z_{  }$ lbs.	$Z_{\perp}$ lbs.	$Z_{m\perp}$ lbs.	$Z_{  }$ lbs.	$Z_{\perp}$ lbs.	$Z_{m\perp}$ lbs.	$Z_{  }$ lbs.	$Z_{\perp}$ lbs.	$Z_{m\perp}$ lbs.	$Z_{  }$ lbs.	$Z_{\perp}$ lbs.	$Z_{m\perp}$ lbs.	$Z_{  }$ lbs.	$Z_{\perp}$ lbs.	$Z_{m\perp}$ lbs.
× 25.4 for mm			× 4.45 for N																	
2 1/2	1 1/2	1/2	—	—	—	1,230	730	790	1,160	680	700	1,100	650	640	1,080	640	610	980	560	490
		5/8	—	—	—	1,760	1,040	880	1,660	940	780	1,590	840	700	1,570	830	690	1,430	660	550
		3/4	—	—	—	2,400	1,170	980	2,280	1,040	860	2,190	920	770	2,160	900	750	1,900	720	600
		7/8	—	—	—	3,060	1,260	1,050	2,820	1,100	920	2,630	1,000	830	2,570	970	810	2,210	790	660
		1	—	—	—	3,500	1,350	1,130	3,220	1,200	1,000	3,000	1,080	900	2,940	1,050	880	2,530	840	700
3	1 1/2	1/2	1,320	800	940	—	—	—	—	—	—	—	—	—	—	—	—	—	—	—
		5/8	1,870	1,130	1,220	—	—	—	—	—	—	—	—	—	—	—	—	—	—	—
		3/4	2,550	1,330	1,330	—	—	—	—	—	—	—	—	—	—	—	—	—	—	—
		7/8	3,360	1,440	1,440	—	—	—	—	—	—	—	—	—	—	—	—	—	—	—
		1	4,310	1,530	1,530	—	—	—	—	—	—	—	—	—	—	—	—	—	—	—
3 1/8	1 1/2	1/2	—	—	—	1,230	730	860	1,160	680	810	1,100	650	760	1,080	640	740	980	560	610
		5/8	—	—	—	1,760	1,040	1,090	1,660	940	980	1,590	840	880	1,570	830	860	1,430	660	680
		3/4	—	—	—	2,400	1,170	1,220	2,280	1,040	1,080	2,190	920	960	2,160	900	940	1,990	720	750
		7/8	—	—	—	3,180	1,260	1,310	3,030	1,100	1,150	2,920	1,000	1,040	2,880	970	1,010	2,660	790	820
		1	—	—	—	4,090	1,350	1,410	3,860	1,200	1,250	3,600	1,080	1,130	3,530	1,050	1,090	3,040	840	880
5	1 1/2	5/8	1,870	1,130	1,290	—	—	—	—	—	—	—	—	—	—	—	—	—	—	—
		3/4	2,550	1,330	1,690	—	—	—	—	—	—	—	—	—	—	—	—	—	—	—
		7/8	3,360	1,440	2,170	—	—	—	—	—	—	—	—	—	—	—	—	—	—	—
		1	4,310	1,530	2,550	—	—	—	—	—	—	—	—	—	—	—	—	—	—	—
		5/8	—	—	—	1,760	1,040	1,190	1,660	940	1,110	1,590	840	1,050	1,570	830	1,040	1,430	660	920
5 1/8	1 1/2	3/4	—	—	—	2,400	1,170	1,580	2,280	1,040	1,480	2,190	920	1,400	2,160	900	1,380	1,990	720	1,230
		7/8	—	—	—	3,180	1,260	2,030	3,030	1,100	1,880	2,920	1,000	1,700	2,880	970	1,660	2,660	790	1,350
		1	—	—	—	4,090	1,350	2,310	3,860	1,200	2,050	3,600	1,080	1,850	3,530	1,050	1,790	3,040	840	1,440
		5/8	1,870	1,130	1,290	1,760	1,040	1,190	1,660	940	1,110	1,590	840	1,050	1,570	830	1,040	1,430	660	920
		3/4	2,550	1,330	1,690	2,400	1,170	1,580	2,280	1,040	1,480	2,190	920	1,400	2,160	900	1,380	1,990	720	1,230
6 3/4	1 1/2	7/8	3,360	1,440	2,170	3,180	1,260	2,030	3,030	1,100	1,900	2,920	1,000	1,800	2,880	970	1,780	2,660	790	1,600
		1	4,310	1,530	2,700	4,090	1,350	2,530	3,860	1,200	2,390	3,600	1,080	2,270	3,530	1,050	2,240	3,040	840	1,890

<sup>1</sup>Tabulated lateral design values (Z) for bolted connections shall be multiplied by all applicable adjustment factors (see Table 23-III-A).

<sup>2</sup>Tabulated lateral design values (Z) are for "full diameter" bolts with a bending yield strength ( $F_{yb}$ ) of 45,000 psi (310 N/mm<sup>2</sup>).

**TABLE 23-III-Q—BOLT DESIGN VALUES (Z) FOR DOUBLE SHEAR (Three-member) CONNECTIONS<sup>1,2,3</sup> FOR GLUED-LAMINATED TIMBER WITH 1/4-1NCH (6.4 mm) ASTM A 36 STEEL SIDE PLATE**

THICKNESS		BOLT DIAMETER, D inches	G = 0.55 SOUTHERN PINE		G = 0.50 DOUGLAS FIR- LARCH		G = 0.46 DOUGLAS FIR (S)		G = 0.43 HEM-FIR		G = 0.42 SPRUCE-PINE-FIR		G = 0.36 SPRUCE-PINE-FIR (S) WESTERN WOODS	
Main Member t <sub>m</sub> inches	Steel Side Plate t <sub>s</sub> inches		Z <sub>  </sub> lbs.	Z <sub>⊥</sub> lbs.	Z <sub>  </sub> lbs.	Z <sub>⊥</sub> lbs.	Z <sub>  </sub> lbs.	Z <sub>⊥</sub> lbs.	Z <sub>  </sub> lbs.	Z <sub>⊥</sub> lbs.	Z <sub>  </sub> lbs.	Z <sub>⊥</sub> lbs.	Z <sub>  </sub> lbs.	Z <sub>⊥</sub> lbs.
× 25.4 for mm			× 4.45 for N											
2 1/2	1/4	1/2	—	—	1,510	790	1,460	700	1,410	640	1,400	610	1,270	490
		5/8	—	—	2,190	880	2,010	780	1,880	700	1,840	690	1,580	550
		3/4	—	—	2,630	980	2,410	860	2,250	770	2,200	750	1,900	600
		7/8	—	—	3,060	1,050	2,820	920	2,630	830	2,570	810	2,210	660
		1	—	—	3,500	1,130	3,220	1,000	3,000	900	2,940	880	2,530	700
3	1/4	1/2	1,570	1,000	—	—	—	—	—	—	—	—	—	—
		5/8	2,350	1,220	—	—	—	—	—	—	—	—	—	—
		3/4	3,300	1,330	—	—	—	—	—	—	—	—	—	—
		7/8	4,040	1,440	—	—	—	—	—	—	—	—	—	—
		1	4,610	1,530	—	—	—	—	—	—	—	—	—	—
3 1/8	1/4	1/2	—	—	1,510	940	1,460	880	1,410	800	1,400	770	1,310	610
		5/8	—	—	2,250	1,090	2,170	980	2,110	880	2,090	860	1,960	680
		3/4	—	—	3,170	1,220	3,020	1,080	2,810	960	2,750	940	2,370	750
		7/8	—	—	3,830	1,310	3,520	1,150	3,280	1,040	3,210	1,010	2,770	820
		1	—	—	4,380	1,410	4,020	1,250	3,750	1,130	3,670	1,090	3,160	880
5	1/4	5/8	2,350	1,420	—	—	—	—	—	—	—	—	—	—
		3/4	3,300	1,910	—	—	—	—	—	—	—	—	—	—
		7/8	4,440	2,410	—	—	—	—	—	—	—	—	—	—
		1	5,750	2,550	—	—	—	—	—	—	—	—	—	—
5 1/8	1/4	5/8	—	—	2,250	1,330	2,170	1,260	2,110	1,200	2,090	1,190	1,960	1,070
		3/4	—	—	3,170	1,800	3,060	1,700	2,960	1,580	2,940	1,540	2,750	1,230
		7/8	—	—	4,260	2,150	4,100	1,880	3,980	1,700	3,940	1,660	3,690	1,350
		1	—	—	5,520	2,310	5,320	2,050	5,150	1,850	5,110	1,790	4,770	1,440

6 <sup>3/4</sup>	1/4	5/8	2,350	1,420	2,250	1,330	2,170	1,260	2,110	1,200	2,090	1,190	1,960	1,070
		3/4	3,300	1,910	3,170	1,800	3,060	1,700	2,960	1,610	2,940	1,590	2,750	1,440
		7/8	4,440	2,470	4,260	2,320	4,100	2,180	3,980	2,080	3,940	2,060	3,690	1,770
		1	5,750	3,090	5,520	2,910	5,320	2,700	5,150	2,430	5,110	2,360	4,770	1,890
8 <sup>1/2</sup>	1/4	3/4	3,300	1,910	—	—	—	—	—	—	—	—	—	—
		7/8	4,440	2,470	—	—	—	—	—	—	—	—	—	—
		1	5,750	3,090	—	—	—	—	—	—	—	—	—	—
8 <sup>3/4</sup>	1/4	3/4	—	—	3,170	1,800	3,060	1,700	2,960	1,610	2,940	1,590	2,750	1,440
		7/8	—	—	4,260	2,320	4,100	2,180	3,980	2,080	3,940	2,060	3,690	1,860
		1	—	—	5,520	2,910	5,320	2,750	5,150	2,620	5,110	2,590	4,770	2,330
10 <sup>1/2</sup>	1/4	7/8	4,440	2,470	—	—	—	—	—	—	—	—	—	—
		1	5,750	3,090	—	—	—	—	—	—	—	—	—	—
10 <sup>3/4</sup>	1/4	7/8	—	—	4,260	2,320	4,100	2,180	3,980	2,080	3,940	2,060	3,690	1,860
		1	—	—	5,520	2,910	5,320	2,750	5,150	2,620	5,110	2,590	4,770	2,330
12 <sup>1/4</sup>	1/4	7/8	—	—	4,260	2,320	4,100	2,180	3,980	2,080	3,940	2,060	3,690	1,860
		1	—	—	5,520	2,910	5,320	2,750	5,150	2,620	5,110	2,590	4,770	2,330
14 <sup>1/4</sup>	1/4	1	—	—	5,520	2,910	5,320	2,750	5,150	2,620	5,110	2,590	4,770	2,330

<sup>1</sup>Tabulated lateral design values (Z) for bolted connections shall be multiplied by all applicable adjustment factors (see Table 23-III-A).

<sup>2</sup>Tabulated lateral design values (Z) are for “full diameter” bolts with a bending yield strength ( $F_{yb}$ ) of 45,000 psi (310 N/mm<sup>2</sup>).

<sup>3</sup>Tabulated lateral design values (Z) are based on a dowel-bearing strength ( $F_e$ ) of 58,000 psi (400 N/mm<sup>2</sup>) for ASTM A 36 steel.

TABLE 23-III-R—DOWEL-BEARING STRENGTH FOR LAG SCREW CONNECTIONS

SPECIES COMBINATION	SPECIFIC GRAVITY G	DOWEL-BEARING STRENGTH IN POUNDS PER SQUARE INCH (psi)											
		$\times 6.89 \times 10^{-3}$ for N/mm <sup>2</sup>											
		$F_{e\parallel}$	$F_{e\perp}$ D=1/4 inch (6.4 mm)	$F_{e\perp}$ D=5/16 inch (7.9 mm)	$F_{e\perp}$ D=3/8 inch (9.5 mm)	$F_{e\perp}$ D=7/16 inch (11 mm)	$F_{e\perp}$ D=1/2 inch (13 mm)	$F_{e\perp}$ D=5/8 inch (16 mm)	$F_{e\perp}$ D=3/4 inch (19 mm)	$F_{e\perp}$ D=7/8 inch (22 mm)	$F_{e\perp}$ D=1 inch (25 mm)	$F_{e\perp}$ D=1 1/8 inches (29 mm)	$F_{e\perp}$ D=1 1/4 inches (32 mm)
Aspen	0.39	4,350	3,100	2,800	2,550	2,350	2,200	1,950	1,800	1,650	1,550	1,450	1,400
Balsam fir	0.36	4,050	2,750	2,500	2,250	2,100	1,950	1,750	1,600	1,500	1,400	1,300	1,250
Beech-birch-hickory	0.71	7,950	7,400	6,650	6,050	5,600	5,250	4,700	4,300	3,950	3,700	3,500	3,300
Coast sitka spruce	0.39	4,350	3,100	2,800	2,550	2,350	2,200	1,950	1,800	1,650	1,550	1,450	1,400
Cottonwood	0.41	4,600	3,350	3,000	2,750	2,550	2,350	2,100	1,950	1,800	1,650	1,600	1,500
Douglas fir-larch	0.50	5,600	4,450	4,000	3,650	3,400	3,150	2,800	2,600	2,400	2,250	2,100	2,000
Douglas fir-larch (north)	0.49	5,500	4,350	3,900	3,550	3,300	3,050	2,750	2,500	2,300	2,150	2,050	1,950
Douglas fir-south	0.46	5,150	3,950	3,550	3,250	3,000	2,800	2,500	2,300	2,100	2,000	1,850	1,750
Eastern hemlock	0.41	4,600	3,350	3,000	2,750	2,550	2,350	2,100	1,950	1,800	1,650	1,600	1,500
Eastern hemlock-tamarack	0.41	4,600	3,350	3,000	2,750	2,550	2,350	2,100	1,950	1,800	1,650	1,600	1,500
Eastern hemlock-tamarack (north)	0.47	5,250	4,100	3,650	3,350	3,100	2,900	2,600	2,350	2,200	2,050	1,900	1,850
Eastern softwoods	0.36	4,050	2,750	2,500	2,250	2,100	1,950	1,750	1,600	1,500	1,400	1,300	1,250
Eastern spruce	0.41	4,600	3,350	3,000	2,750	2,550	2,350	2,100	1,950	1,800	1,650	1,600	1,500
Eastern white pine	0.36	4,050	2,750	2,500	2,250	2,100	1,950	1,750	1,600	1,500	1,400	1,300	1,250
Engelmann spruce-lodgepole pine <sup>2</sup> (MSR 1650f and higher grades)	0.46	5,150	3,950	3,550	3,250	3,000	2,800	2,500	2,300	2,100	2,000	1,850	1,750
Engelmann spruce-lodgepole pine <sup>2</sup> (MSR 1500f and lower grades)	0.38	4,250	3,000	2,700	2,450	2,250	2,100	1,900	1,750	1,600	1,500	1,400	1,350

Hem-fir	0.43	4,800	3,600	3,200	2,950	2,700	2,550	2,250	2,050	1,900	1,800	1,700	1,600
Hem-fir (north)	0.46	5,150	3,950	3,550	3,250	3,000	2,800	2,500	2,300	2,100	2,000	1,850	1,750
Mixed maple	0.55	6,150	5,150	4,600	4,200	3,900	3,650	3,250	2,950	2,750	2,550	2,400	2,300
Mixed oak	0.68	7,600	6,950	6,250	5,700	5,250	4,950	4,400	4,050	3,750	3,500	3,300	3,100
Mixed southern pine	0.51	5,700	4,600	4,100	3,750	3,450	3,250	2,900	2,650	2,450	2,300	2,150	2,050
Mountain hemlock	0.47	5,250	4,100	3,650	3,350	3,100	2,900	2,600	2,350	2,200	2,050	1,900	1,850
Northern pine	0.42	4,700	3,450	3,100	2,850	2,600	2,450	2,200	2,000	1,850	1,750	1,650	1,550
Northern red oak	0.68	7,600	6,950	6,250	5,700	5,250	4,950	4,400	4,050	3,750	3,500	3,300	3,100
Northern species	0.35	3,900	2,650	2,400	2,150	2,000	1,900	1,700	1,550	1,400	1,350	1,250	1,200
Northern white cedar	0.31	3,450	2,250	2,000	1,800	1,700	1,600	1,400	1,300	1,200	1,100	1,050	1,000
Ponderosa pine	0.43	4,800	3,600	3,200	2,950	2,700	2,550	2,250	2,050	1,900	1,800	1,700	1,600
Red maple	0.58	6,500	5,550	4,950	4,500	4,200	3,900	3,500	3,200	2,950	2,750	2,600	2,500
Red oak	0.67	7,500	6,850	6,100	5,550	5,150	4,850	4,300	3,950	3,650	3,400	3,200	3,050
Red pine	0.44	4,950	3,700	3,300	3,050	2,800	2,600	2,350	2,150	2,000	1,850	1,750	1,650
Redwood, close grain	0.44	4,950	3,700	3,300	3,050	2,800	2,600	2,350	2,150	2,000	1,850	1,750	1,650
Redwood, open grain	0.37	4,150	2,900	2,600	2,350	2,200	2,050	1,850	1,650	1,550	1,450	1,350	1,300
Sitka spruce	0.43	4,800	3,600	3,200	2,950	2,700	2,550	2,250	2,050	1,900	1,800	1,700	1,600
Southern pine	0.55	6,150	5,150	4,600	4,200	3,900	3,650	3,250	2,950	2,750	2,550	2,400	2,300
Spruce-pine-fir	0.42	4,700	3,450	3,100	2,850	2,600	2,450	2,200	2,000	1,850	1,750	1,650	1,550
Spruce-pine-fir (south)	0.36	4,050	2,750	2,500	2,250	2,100	1,950	1,750	1,600	1,500	1,400	1,300	1,250
Western cedars	0.36	4,050	2,750	2,500	2,250	2,100	1,950	1,750	1,600	1,500	1,400	1,300	1,250
Western cedars (north)	0.35	3,900	2,650	2,400	2,150	2,000	1,900	1,700	1,550	1,400	1,350	1,250	1,200
Western hemlock	0.47	5,250	4,100	3,650	3,350	3,100	2,900	2,600	2,350	2,200	2,050	1,900	1,850
Western hemlock (north)	0.46	5,150	3,950	3,550	3,250	3,000	2,800	2,500	2,300	2,100	2,000	1,850	1,750
Western white pine	0.40	4,500	3,250	2,900	2,650	2,450	2,300	2,050	1,850	1,750	1,600	1,500	1,450
Western woods	0.36	4,050	2,750	2,500	2,250	2,100	1,950	1,750	1,600	1,500	1,400	1,300	1,250
White oak	0.73	8,200	7,750	6,900	6,300	5,850	5,450	4,900	4,450	4,150	3,850	3,650	3,450
Yellow poplar	0.43	4,800	3,600	3,200	2,950	2,700	2,550	2,250	2,050	1,900	1,800	1,700	1,600

<sup>1</sup>Specific gravity based on weight and volume when oven dry.

<sup>2</sup>Applies only to Engelmann spruce-lodgepole pine machine-stress-rated (MSR) structural lumber.

**TABLE 23-III-S—LAG SCREW WITHDRAWAL DESIGN VALUES (W)<sup>1</sup>**

Tabulated withdrawal design values are in pounds per inch (N/mm<sup>2</sup>) of thread penetration into side grain of main member.  
Length of thread penetration in main member shall not include the length of the tapered tip (see Table 23-III-SS).  
( $\times 6.89 \times 10^{-3}$  for N/mm<sup>2</sup>)

SPECIFIC GRAVITY, G	LAG SCREW UNTHREADED SHANK DIAMETER, D										
	1/4 inch (6.4 mm)	5/16 inch (7.9 mm)	3/8 inch (9.5 mm)	7/16 inch (11 mm)	1/2 inch (13 mm)	5/8 inch (16 mm)	3/4 inch (19 mm)	7/8 inch (22 mm)	1 inch (25 mm)	1 1/8 inches (29 mm)	1 1/4 inches (32 mm)
0.73	397	469	538	604	668	789	905	1,016	1,123	1,226	1,327
0.71	381	450	516	579	640	757	868	974	1,077	1,176	1,273
0.68	357	422	484	543	600	709	813	913	1,009	1,103	1,193
0.67	349	413	473	531	587	694	796	893	987	1,078	1,167
0.58	281	332	381	428	473	559	641	719	795	869	940
0.55	260	307	352	395	437	516	592	664	734	802	868
0.51	232	274	314	353	390	461	528	593	656	716	775
0.50	225	266	305	342	378	447	513	576	636	695	752
0.49	218	258	296	332	367	434	498	559	617	674	730
0.47	205	242	278	312	345	408	467	525	580	634	686
0.46	199	235	269	302	334	395	453	508	562	613	664
0.44	186	220	252	283	312	369	423	475	525	574	621
0.43	179	212	243	273	302	357	409	459	508	554	600
0.42	173	205	235	264	291	344	395	443	490	535	579
0.41	167	198	226	254	281	332	381	428	473	516	559
0.40	161	190	218	245	271	320	367	412	455	497	538
0.39	155	183	210	236	261	308	353	397	438	479	518
0.38	149	176	202	227	251	296	340	381	422	461	498
0.37	143	169	194	218	241	285	326	367	405	443	479
0.36	137	163	186	209	231	273	313	352	389	425	460
0.35	132	156	179	200	222	262	300	337	373	407	441
0.31	110	130	149	167	185	218	250	281	311	339	367

<sup>1</sup>Tabulated withdrawal design values (W) for lag screw connections shall be multiplied by all applicable adjustment factors (see Table 23-III-A).

TABLE 23-III-T—LAG SCREW DESIGN VALUES (Z) FOR SINGLE SHEAR (Two-member) CONNECTIONS<sup>1,2</sup>  
WITH BOTH MEMBERS OF IDENTICAL SPECIES

SIDE MEMBER THICKNESS $\frac{t}{8}$ inches	LAG SCREW DIAMETER D inches	G = 0.67 RED OAK			G = 0.55 MIXED MAPLE SOUTHERN PINE			G = 0.50 DOUGLAS FIR-LARCH			G = 0.49 DOUGLAS FIR-LARCH (N)			G = 0.46 DOUGLAS FIR (S) HEM-FIR (N)		
		Z <sub>  </sub> lbs.	Z <sub>⊥</sub> lbs.	Z <sub>m⊥</sub> lbs.	Z <sub>  </sub> lbs.	Z <sub>⊥</sub> lbs.	Z <sub>m⊥</sub> lbs.	Z <sub>  </sub> lbs.	Z <sub>⊥</sub> lbs.	Z <sub>m⊥</sub> lbs.	Z <sub>  </sub> lbs.	Z <sub>⊥</sub> lbs.	Z <sub>m⊥</sub> lbs.	Z <sub>  </sub> lbs.	Z <sub>⊥</sub> lbs.	Z <sub>m⊥</sub> lbs.
× 25.4 for mm		× 4.45 for N														
1/2	1/4	190	150	150	170	130	130	160	110	120	160	110	120	150	100	120
	5/16	270	190	210	240	140	180	220	130	170	210	120	170	200	110	160
	3/8	340	210	250	290	160	220	260	140	200	260	130	200	240	120	190
5/8	1/4	210	160	160	180	130	140	170	120	130	170	120	130	160	120	120
	5/16	290	210	220	250	180	190	240	160	180	240	150	170	230	140	170
	3/8	350	250	260	310	200	230	290	170	210	290	170	210	280	150	200
3/4	1/4	230	170	180	200	140	150	180	130	140	180	130	140	170	120	130
	5/16	310	220	240	270	190	200	250	170	190	250	170	180	240	160	170
	3/8	380	260	280	330	220	240	310	210	220	310	200	220	290	180	210
1	1/4	260	200	200	230	160	180	210	150	160	210	150	160	200	140	150
	5/16	360	250	270	300	210	230	280	190	210	280	190	210	270	170	200
	3/8	430	290	330	370	240	270	350	220	250	340	220	250	330	210	240
1 1/4	1/4	260	200	200	230	180	180	220	170	170	220	170	170	210	150	160
	5/16	370	280	280	340	230	250	320	210	240	320	210	230	300	190	220
	3/8	470	330	340	420	270	300	390	240	290	390	240	280	370	220	270
1 1/2	1/4	260	200	200	230	180	180	220	170	170	220	170	170	210	160	160
	5/16	370	280	280	340	250	250	320	230	240	320	230	230	310	210	220
	3/8	470	340	340	420	300	300	400	270	290	400	260	280	390	240	270

(Continued)

TABLE 23-III-T—LAG SCREW DESIGN VALUES (Z) FOR SINGLE SHEAR (Two-member) CONNECTIONS<sup>1,2</sup>  
WITH BOTH MEMBERS OF IDENTICAL SPECIES—(Continued)

SIDE MEMBER THICKNESS $t_2$ Inches	LAG SCREW DIAMETER $D$ Inches	G = 0.67 RED OAK			G = 0.55 MIXED MAPLE SOUTHERN PINE			G = 0.50 DOUGLAS FIR-LARCH			G = 0.49 DOUGLAS FIR-LARCH (N)			G = 0.46 DOUGLAS FIR (S) HEM-FIR (N)		
		$Z_{  }$ lbs.	$Z_{\perp}$ lbs.	$Z_{m\perp}$ lbs.	$Z_{  }$ lbs.	$Z_{\perp}$ lbs.	$Z_{m\perp}$ lbs.	$Z_{  }$ lbs.	$Z_{\perp}$ lbs.	$Z_{m\perp}$ lbs.	$Z_{  }$ lbs.	$Z_{\perp}$ lbs.	$Z_{m\perp}$ lbs.	$Z_{  }$ lbs.	$Z_{\perp}$ lbs.	$Z_{m\perp}$ lbs.
× 25.4 for mm		× 4.45 for N														
1½ cont.	7/16	630	430	460	570	350	400	540	320	380	540	310	380	510	290	360
	1/2	830	510	590	710	420	500	660	380	460	650	370	450	610	350	430
	5/8	1,140	670	800	980	570	680	920	530	620	910	520	620	870	470	580
	3/4	1,510	890	1,040	1,320	660	880	1,240	590	820	1,220	560	800	1,170	520	760
	7/8	1,940	960	1,300	1,710	720	1,110	1,620	630	1,040	1,600	600	1,020	1,540	550	970
	1	2,450	1,020	1,600	2,170	770	1,370	2,060	680	1,290	2,040	650	1,260	1,930	600	1,210
	1 1/8	3,030	1,080	1,930	2,590	810	1,670	2,360	710	1,560	2,320	690	1,540	2,170	620	1,460
1 1/4	3,520	1,140	2,300	2,880	860	2,000	2,630	750	1,860	2,580	730	1,840	2,410	660	1,750	
2½	1/4	260	200	200	230	180	180	220	170	170	220	170	170	210	160	160
	5/16	370	280	280	340	250	250	320	240	240	320	230	230	310	220	220
	3/8	470	340	340	420	300	300	400	290	290	400	280	280	390	270	270
	7/16	630	460	460	570	400	400	550	380	380	540	380	380	520	360	360
	1/2	830	590	590	750	520	520	710	480	480	710	480	480	690	450	460
	5/8	1,290	860	880	1,170	700	780	1,120	630	730	1,110	620	720	1,070	580	690
	3/4	1,860	1,060	1,240	1,680	870	1,090	1,570	800	1,020	1,550	780	1,010	1,470	740	970
	7/8	2,460	1,290	1,640	2,100	1,080	1,400	1,950	1,000	1,280	1,930	970	1,260	1,830	920	1,180
	1	2,970	1,550	1,980	2,560	1,280	1,660	2,390	1,130	1,530	2,360	1,080	1,500	2,250	1,000	1,430
	1 1/8	3,550	1,800	2,320	3,080	1,350	1,950	2,880	1,180	1,800	2,850	1,150	1,770	2,720	1,040	1,670
1 1/4	4,190	1,910	2,680	3,650	1,440	2,270	3,430	1,250	2,100	3,390	1,220	2,070	3,250	1,090	1,950	

<sup>1</sup>Tabulated lateral design values (Z) for lag screw connections shall be multiplied by all applicable adjustment factors (see Table 23-III-A).

<sup>2</sup>Tabulated lateral design values (Z) are for "full diameter" lag screws inserted in side grain with lag screw axis perpendicular to wood fibers, and with the following lag screw bending yield strengths ( $F_{yb}$ ):

$F_{yb} = 70,000$  psi (482 N/mm<sup>2</sup>) for  $D = 1/4$  inch (6.4 mm)

$F_{yb} = 60,000$  psi (413 N/mm<sup>2</sup>) for  $D = 5/16$  inch (7.9 mm)

$F_{yb} = 45,000$  psi (310 N/mm<sup>2</sup>) for  $D \geq 3/8$  inch (9.5 mm)

SIDE MEMBER THICKNESS t inches	LAG SCREW DIAMETER D inches	G = 0.43 HEM-FIR			G = 0.42 SPRUCE-PINE-FIR			G = 0.37 REDWOOD (open grain)			G = 0.36 EASTERN SOFTWOODS SPRUCE-PINE-FIR(S) WESTERN CEDARS WESTERN WOODS			G = 0.35 NORTHERN SPECIES		
		Z <sub>  </sub> lbs.	Z <sub>s⊥</sub> lbs.	Z <sub>m⊥</sub> lbs.	Z <sub>  </sub> lbs.	Z <sub>s⊥</sub> lbs.	Z <sub>m⊥</sub> lbs.	Z <sub>  </sub> lbs.	Z <sub>s⊥</sub> lbs.	Z <sub>m⊥</sub> lbs.	Z <sub>  </sub> lbs.	Z <sub>s⊥</sub> lbs.	Z <sub>m⊥</sub> lbs.	Z <sub>  </sub> lbs.	Z <sub>s⊥</sub> lbs.	Z <sub>m⊥</sub> lbs.
× 25.4 for mm		× 4.45 for N														
1/2	1/4	150	90	110	150	90	110	130	70	100	130	70	100	120	70	100
	5/16	190	100	150	180	100	150	160	80	130	160	80	130	150	80	120
	3/8	230	110	180	220	110	180	190	90	160	190	80	150	180	80	150
5/8	1/4	160	110	120	150	110	110	140	90	100	140	90	100	140	80	100
	5/16	220	130	160	210	120	160	200	100	140	200	100	140	190	90	140
	3/8	270	140	190	270	130	190	240	110	170	240	110	170	230	100	160
3/4	1/4	160	110	120	160	110	120	150	100	110	150	100	110	140	100	100
	5/16	230	150	170	220	150	160	210	120	150	200	120	150	200	110	140
	3/8	280	170	200	280	160	200	260	130	180	250	130	170	250	120	170
1	1/4	190	130	140	190	120	140	170	110	120	170	110	120	160	100	120
	5/16	250	160	190	250	160	180	230	140	160	220	140	160	220	140	160
	3/8	310	190	220	300	190	220	280	170	200	270	170	190	270	160	190
1 1/4	1/4	210	140	150	200	140	150	190	120	140	190	120	140	180	110	130
	5/16	280	180	210	280	170	210	250	160	180	250	150	180	240	150	170
	3/8	350	210	250	340	200	250	310	180	220	300	180	210	300	170	210
1 1/2	1/4	210	150	150	200	150	150	190	140	140	190	130	140	190	130	130
	5/16	300	200	210	300	190	210	280	170	190	270	160	190	270	160	190
	3/8	370	230	260	370	220	260	340	190	240	340	190	230	330	180	230
	7/16	480	270	340	470	270	330	430	240	300	420	230	290	410	230	280

(Continued)

TABLE 23-III-T—LAG SCREW DESIGN VALUES (Z) FOR SINGLE SHEAR (Two-member) CONNECTIONS<sup>1,2</sup>  
WITH BOTH MEMBERS OF IDENTICAL SPECIES—(Continued)

SIDE MEMBER THICKNESS $t_b$ inches	LAG SCREW DIAMETER $D$ inches	G = 0.43 HEM-FIR			G = 0.42 SPRUCE-PINE-FIR			G = 0.37 REDWOOD (open grain)			G = 0.36 EASTERN SOFTWOODS SPRUCE-PINE-FIR(S) WESTERN CEDARS WESTERN WOODS			G = 0.35 NORTHERN SPECIES		
		$Z_{  }$	$Z_{\perp}$	$Z_{m\perp}$	$Z_{  }$	$Z_{\perp}$	$Z_{m\perp}$	$Z_{  }$	$Z_{\perp}$	$Z_{m\perp}$	$Z_{  }$	$Z_{\perp}$	$Z_{m\perp}$	$Z_{  }$	$Z_{\perp}$	$Z_{m\perp}$
		lbs.	lbs.	lbs.	lbs.	lbs.	lbs.	lbs.	lbs.	lbs.	lbs.	lbs.	lbs.	lbs.	lbs.	lbs.
× 25.4 for mm		× 4.45 for N														
1 1/2	1/2	580	330	400	570	320	400	520	290	350	510	290	350	500	280	340
	5/8	820	420	550	810	410	540	750	350	490	730	330	480	720	320	470
	3/4	1,120	460	720	1,100	450	710	1,020	370	640	1,010	360	630	980	350	620
	7/8	1,470	500	920	1,450	490	900	1,350	410	820	1,330	390	810	1,280	370	780
	1	1,800	540	1,150	1,760	530	1,130	1,560	440	1,030	1,520	420	1,010	1,460	410	990
	1 1/8	2,030	570	1,400	1,980	560	1,380	1,750	460	1,250	1,710	440	1,230	1,650	420	1,200
	1 1/4	2,250	600	1,670	2,200	580	1,650	1,950	490	1,510	1,900	470	1,480	1,830	450	1,450
2 1/2	1/4	210	150	150	200	150	150	190	140	140	190	140	140	190	130	130
	5/16	300	210	210	300	210	210	280	190	190	270	190	190	270	190	190
	3/8	370	260	260	370	260	260	350	240	240	340	230	230	340	230	230
	7/16	510	340	340	500	340	340	470	310	310	470	300	310	460	290	300
	1/2	660	420	440	650	410	430	620	360	400	610	340	390	600	340	390
	5/8	1,030	540	660	1,020	530	650	960	470	600	940	460	590	910	450	580
	3/4	1,390	690	910	1,360	680	890	1,240	610	800	1,220	600	780	1,180	580	760
	7/8	1,740	830	1,110	1,710	810	1,090	1,560	680	980	1,540	660	960	1,500	610	930
	1	2,140	900	1,340	2,110	880	1,320	1,940	730	1,180	1,910	700	1,160	1,860	680	1,130
	1 1/8	2,600	960	1,590	2,560	930	1,560	2,360	760	1,400	2,330	730	1,370	2,270	700	1,340
	1 1/4	3,110	1,000	1,850	3,070	970	1,820	2,840	810	1,650	2,800	780	1,620	2,740	750	1,580

<sup>1</sup>Tabulated lateral design values (Z) for lag screw connections shall be multiplied by all applicable adjustment factors (see Table 23-III-A).

<sup>2</sup>Tabulated lateral design values (Z) are for "full diameter" lag screws inserted in side grain with lag screw axis perpendicular to wood fibers, and with the following lag screw bending yield strengths ( $F_{yb}$ ):

$F_{yb} = 70,000$  psi (482 N/mm<sup>2</sup>) for  $D = 1/4$  inch (6.4 mm)

$F_{yb} = 60,000$  psi (413 N/mm<sup>2</sup>) for  $D = 5/16$  inch (7.9 mm)

$F_{yb} = 45,000$  psi (310 N/mm<sup>2</sup>) for  $D \geq 3/8$  inch (9.5 mm)

TABLE 23-III-U—LAG SCREW DESIGN VALUES (Z) FOR SINGLE SHEAR (Two-member) CONNECTIONS<sup>1,2,3</sup>  
 WITH 1/4-INCH (6.4 mm) ASTM A 36 STEEL SIDE PLATE OR ASTM A 446 GRADE A STEEL SIDE PLATE [For  $t_s < 1/4$  inch (6.4 mm)]

STEEL SIDE PLATE $t_s$ inches	LAG SCREW DIAMETER D inches	G = 0.67 RED OAK		G = 0.55 MIXED MAPLE SOUTHERN PINE		G = 0.50 DOUGLAS FIR-LARCH		G = 0.49 DOUGLAS FIR-LARCH (N)		G = 0.46 DOUGLAS FIR (S) HEM-FIR (N)	
		$Z_{  }$ lbs.	$Z_{\perp}$ lbs.	$Z_{  }$ lbs.	$Z_{\perp}$ lbs.	$Z_{  }$ lbs.	$Z_{\perp}$ lbs.	$Z_{  }$ lbs.	$Z_{\perp}$ lbs.	$Z_{  }$ lbs.	$Z_{\perp}$ lbs.
× 25.4 for mm		× 4.45 for N									
	1/4	330	260	310	230	300	220	300	210	290	200
	5/16	450	330	410	290	400	280	400	270	390	260
	3/8	550	390	510	350	490	330	480	320	470	310
	7/16	700	480	650	510	620	480	620	470	600	460
	1/2	870	580	810	600	780	560	770	560	750	540
	5/8	1,290	820	1,190	840	1,140	790	1,140	780	1,100	750
	3/4	1,810	1,100	1,660	1,130	1,600	1,060	1,580	1,050	1,540	1,010
	7/8	2,420	1,410	2,220	1,750	2,130	1,640	2,120	1,620	2,060	1,560
	1	3,130	1,760	2,870	2,120	2,750	1,990	2,730	1,970	2,650	1,890
	1 1/8	3,930	2,150	3,610	2,540	3,460	2,380	3,430	2,350	3,340	2,260
	1 1/4	4,840	2,580	4,440	2,990	4,260	2,800	4,220	2,770	4,100	2,660
3 gage $t_s = 0.239"$	1/4	300	230	270	210	260	190	260	190	260	180
	5/16	400	300	370	270	360	250	360	250	350	240
	3/8	500	350	460	320	440	300	440	290	430	280
7 gage $t_s = 0.179"$	1/4	270	210	250	160	240	150	240	150	230	140
	5/16	370	270	340	210	330	200	330	200	320	190
	3/8	460	320	420	250	410	240	400	230	390	220
10 gage $t_s = 0.134"$	1/4	250	190	230	130	220	120	220	120	210	110
	5/16	350	260	330	170	310	160	310	160	300	150
	3/8	440	310	400	210	390	200	390	200	380	190
11 gage $t_s = 0.12"$	1/4	250	190	230	170	220	160	220	160	210	150
	5/16	350	260	320	230	310	210	310	210	300	200
	3/8	430	310	400	270	380	260	380	250	370	240
12 gage $t_s = 0.105"$	1/4	240	190	220	140	210	130	210	130	210	130
	5/16	350	250	320	190	310	180	300	180	300	170
	3/8	430	300	400	230	380	220	380	210	370	200
14 gage $t_s = 0.075"$	1/4	240	180	220	120	210	110	210	110	200	110

(Continued)

1994 UNIFORM BUILDING CODE

23-III-U

2-1029

TABLE 23-II-U—LAG SCREW DESIGN VALUES (Z) FOR SINGLE SHEAR (Two-member) CONNECTIONS<sup>1,2,3</sup> WITH 1/4-INCH (6.4 mm) ASTM A 36 STEEL SIDE PLATE OR ASTM A 446 GRADE A STEEL SIDE PLATE [For  $t_s < 1/4$  inch (6.4 mm)]—(Continued)

STEEL SIDE PLATE $t_s$ inches	LAG SCREW DIAMETER D inches	G = 0.43 HEM-FIR		G = 0.42 SPRUCE-PINE-FIR		G = 0.37 REDWOOD (open grain)		G = 0.36 EASTERN SOFTWOODS SPRUCE-PINE-FIR(S) WESTERN CEDARS WESTERN WOODS		G = 0.35 NORTHERN SPECIES	
		$Z_{  }$ lbs.	$Z_{\perp}$ lbs.	$Z_{  }$ lbs.	$Z_{\perp}$ lbs.	$Z_{  }$ lbs.	$Z_{\perp}$ lbs.	$Z_{  }$ lbs.	$Z_{\perp}$ lbs.	$Z_{  }$ lbs.	$Z_{\perp}$ lbs.
× 25.4 for mm		× 4.45 for N									
1/4	1/4	280	200	280	190	260	180	260	170	250	170
	5/16	370	250	370	250	350	230	350	230	340	220
	3/8	460	300	450	290	430	270	430	270	420	260
	7/16	580	370	580	430	550	400	540	390	540	390
	1/2	730	440	720	510	680	470	680	460	670	450
	5/8	1,070	610	1,060	710	1,010	650	1,000	640	980	630
	3/4	1,490	820	1,480	950	1,400	870	1,390	850	1,360	830
	7/8	1,990	1,050	1,980	1,470	1,870	1,350	1,850	1,330	1,820	1,300
	1	2,570	1,310	2,550	1,770	2,410	1,640	2,380	1,600	2,340	1,570
	1 1/8	3,230	1,600	3,200	2,120	3,030	1,950	2,990	1,920	2,940	1,880
1 1/4	3,970	1,910	3,930	2,500	3,720	2,290	3,680	2,240	3,610	2,190	
3 gage $t_s = 0.239$ "	1/4	250	180	250	170	240	160	230	160	230	160
	5/16	340	230	340	230	320	210	320	210	310	200
	3/8	420	270	410	270	390	250	390	240	380	240
7 gage $t_s = 0.179$ "	1/4	220	160	220	130	210	120	210	120	200	120
	5/16	310	210	310	180	290	160	290	160	280	160
	3/8	380	250	380	210	360	190	360	190	350	190

10 gage $t_s = 0.134''$	$1/4$	210	150	210	110	200	100	190	100	190	90
	$5/16$	290	200	290	150	280	130	270	130	270	130
	$3/8$	360	240	360	180	340	160	340	160	330	160
11 gage $t_s = 0.12''$	$1/4$	200	140	200	140	190	130	190	130	190	130
	$5/16$	290	190	290	190	270	180	270	170	260	170
	$3/8$	360	230	360	230	340	210	330	210	330	200
12 gage $t_s = 0.105''$	$1/4$	200	140	200	120	190	110	190	110	180	110
	$5/16$	290	190	280	160	270	150	270	150	260	140
	$3/8$	360	230	350	190	330	180	330	170	320	170
14 gage $t_s = 0.075''$	$1/4$	200	140	190	100	180	90	180	90	180	90

<sup>1</sup>Tabulated lateral design values ( $Z$ ) for lag screw connections shall be multiplied by all applicable adjustment factors (see Table 23-III-A).

<sup>2</sup>Tabulated lateral design values ( $Z$ ) are for "full diameter" lag screws inserted in side grain with lag screw axis perpendicular to wood fibers, and with the following lag screw bending yield strengths ( $F_{yb}$ ).

$F_{yb} = 70,000$  psi (482 N/mm<sup>2</sup>) for  $D = 1/4$  inch (6.4 mm)

$F_{yb} = 60,000$  psi (413 N/mm<sup>2</sup>) for  $D = 5/16$  inch (7.9 mm)

$F_{yb} = 45,000$  psi (310 N/mm<sup>2</sup>) for  $D \geq 3/8$  inch (9.5 mm)

<sup>3</sup>Tabulated lateral design values ( $Z$ ) are based on dowel-bearing strength ( $F_e$ ) of 58,000 psi (400 N/mm<sup>2</sup>) for ASTM A 36 steel and 45,000 psi (310 N/mm<sup>2</sup>) for ASTM A 446 Grade A steel.

TABLE 23-III-V—SPECIES GROUPS FOR SPLIT RING AND SHEAR PLATE CONNECTORS

GROUP A	GROUP B	GROUP C	GROUP D
Beech-birch-hickory	Douglas fir-larch	Douglas fir-south	Apsen
Douglas fir-larch (dense)	Douglas fir-larch (north)	Eastern hemlock-tamarack (north)	Balsam fir
Mixed oak	Mixed maple	Hem-fir	Coast sitka spruce
Northern red oak	Mixed southern pine	Hem-fir (north)	Cottonwood
Red oak	Red maple	Mountain hemlock	Eastern hemlock
Southern pine (dense)	Southern pine <sup>1</sup>	Northern pine	Eastern hemlock-tamarack
White oak		Ponderosa pine	Eastern softwoods
		Red pine	Eastern spruce
		Redwood (close grain)	Eastern white pine
		Sitka spruce	Northern species
		Spruce-pine-fir	Northern white cedar
		Western hemlock	Redwood (open grain)
		Western hemlock (north)	Spruce-pine-fir (south)
		Yellow poplar	Western cedars
			Western cedars (north)
			Western white pine
			Western woods

<sup>1</sup>Coarse grain southern pine, as used in some glued-laminated timber combinations, is in Group C.

**TABLE 23-III-W—SPLIT RING CONNECTOR UNIT DESIGN VALUES**  
**TABULATED DESIGN VALUES APPLY TO ONE SPLIT RING AND BOLT IN SINGLE SHEAR<sup>1</sup>**

SPLIT RING DIAMETER, inches	BOLT DIAMETER, inches	NUMBER OF FACES OF MEMBER WITH CONNECTORS ON SAME BOLT	NET THICKNESS OF MEMBER, inches	LOADED PARALLEL TO GRAIN (0°)				LOADED PERPENDICULAR TO GRAIN (90°)			
				Design value, <i>P</i> , per connector unit and bolt, pounds				Design value, <i>Q</i> , per connector unit and bolt, pounds			
				× 4.45 for N							
× 25.4 for mm			× 25.4 for mm	Group A species	Group B species	Group C species	Group D species	Group A species	Group B species	Group C species	Group D species
2 1/2	1/2		1	1 minimum	2,630	2,270	1,900	1,640	1,900	1,620	1,350
		1 1/2 or thicker		3,160	2,730	2,290	1,960	2,280	1,940	1,620	1,390
		2	1 1/2 minimum	2,430	2,100	1,760	1,510	1,750	1,500	1,250	1,070
			2 or thicker	3,160	2,730	2,290	1,960	2,280	1,940	1,620	1,390
4	3/4	1	1 minimum	4,090	3,510	2,920	2,520	2,840	2,440	2,040	1,760
			1 1/2	6,020	5,160	4,280	3,710	4,180	3,590	2,990	2,580
			1 5/8 or thicker	6,140	5,260	4,380	3,790	4,270	3,660	3,050	2,630
		2	1 1/2 minimum	4,110	3,520	2,940	2,540	2,980	2,450	2,040	1,760
			2	4,950	4,250	3,540	3,050	3,440	2,960	2,460	2,120
			2 1/2	5,830	5,000	4,160	3,600	4,050	3,480	2,890	2,500
3 or thicker	6,140	5,260	4,380	3,790	4,270	3,660	3,050	2,630			

<sup>1</sup>Tabulated lateral design values (*P*,*Q*) for split ring connector units shall be multiplied to all applicable adjustment factors (see Table 23-III-A).

**TABLE 23-III-X—SHEAR PLATE CONNECTOR UNIT DESIGN VALUES**  
**TABULATED DESIGN VALUES APPLY TO ONE SHEAR PLATE UNIT AND BOLT IN SINGLE SHEAR<sup>1,2</sup>**

SHEAR PLATE DIAMETER, inches	BOLT DIAMETER, inches	NUMBER OF FACES OF MEMBER WITH CONNECTORS ON SAME BOLT	NET THICKNESS OF MEMBER, inches	LOADED PARALLEL TO GRAIN (0 degrees)				LOADED PERPENDICULAR TO GRAIN (90 degrees)							
				Design value, P, per connector unit and bolt, pounds								Design value, Q, per connector unit and bolt, pounds			
				× 4.45 for N											
× 25.4 for mm			× 25.4 for mm	Group A species	Group B species	Group C species	Group D species	Group A species	Group B species	Group C species	Group D species				
2 <sup>5</sup> / <sub>8</sub>	3/4	1	1 <sup>1</sup> / <sub>2</sub> minimum	3,110*	2,670	2,220	2,010	2,170	1,860	1,550	1,330				
		2	1 <sup>1</sup> / <sub>2</sub> minimum	2,420	2,080	1,730	1,500	1,690	1,450	1,210	1,040				
			2	3,190*	2,730	2,270	1,960	2,220	1,910	1,580	1,370				
			2 <sup>1</sup> / <sub>2</sub> or thicker	3,330*	2,860	2,380	2,060	2,320	1,990	1,650	1,440				
4	3/4 or 7/8	1	1 <sup>1</sup> / <sub>2</sub> minimum	4,370	3,750	3,130	2,700	3,040	2,620	2,170	1,860				
			1 <sup>3</sup> / <sub>4</sub> or thicker	5,090*	4,360	3,640	3,140	3,540	3,040	2,530	2,200				
		2	1 <sup>3</sup> / <sub>4</sub> minimum	3,390	2,910	2,420	2,090	2,360	2,020	1,680	1,410				
			2	3,790	3,240	2,700	2,330	2,640	2,260	1,880	1,630				
			2 <sup>1</sup> / <sub>2</sub>	4,310	3,690	3,080	2,660	3,000	2,550	2,140	1,850				
			3	4,830*	4,140	3,450	2,980	3,360	2,880	2,400	2,060				
	3 <sup>1</sup> / <sub>2</sub> or thicker	5,030*	4,320	3,600	3,110	3,500	3,000	2,510	2,160						

<sup>1</sup>Tabulated lateral design values (P,Q) for shear plate connector units shall be multiplied to all applicable adjustment factors (see Table 23-III-A).

<sup>2</sup>Allowable design values for shear plate connector units shall not exceed the following:

- (a) 2<sup>5</sup>/<sub>8</sub>-inch (67 mm) shear plate 2,900 pounds (12 905 N)
- (b) 4-inch (102 mm) shear plate with 3/4-inch (19 mm) bolt 4,400 pounds (19 580 N)
- (c) 4-inch (102 mm) shear plate with 7/8-inch (22 mm) bolt 6,000 pounds (26 700 N)

The design values in Footnote 2 shall be permitted to be increased in accordance with the American Institute of Steel Construction (AISC) *Manual of Steel Construction*, 9th edition, Section A5.2 "Wind and Seismic Stresses," except when design loads have already been reduced by load combination factors.

\*These loads exceed those permitted by Footnote 2, but are needed for determination of design values for other angles of load to grain. Footnote 2 limitations apply in all cases.

**TABLE 23-III-Y—PENETRATION DEPTH FACTORS,  $C_d$ , FOR SPLIT RING AND SHEAR PLATE CONNECTORS USED WITH LAG SCREWS**

	SIDE MEMBER	PENETRATION	PENETRATION OF LAG SCREW INTO MAIN MEMBER (NUMBER OF SHANK DIAMETERS)				PENETRATION DEPTH FACTOR, $C_d$
			Species Group (see Table 23-III-V)				
			Group A	Group B	Group C	Group D	
2 1/2" (64 mm) split ring 4" (102 mm) split ring 4" (102 mm) shear plate	Wood or metal	Minimum for full design value	7	8	10	11	1.0
		Minimum for reduced design value	3	3 1/2	4	4 1/2	0.75
2 5/8" (67 mm) shear plate	Wood	Minimum for full design value	4	5	7	8	1.0
		Minimum for reduced design value	3	3 1/2	4	4 1/2	0.75
	Metal	Minimum for full design value	3	3 1/2	4	4 1/2	1.0

**TABLE 23-III-Z—METAL SIDE PLATE FACTORS,  $C_{st}$ , FOR 4-INCH (102 mm) SHEAR PLATE CONNECTORS LOADED PARALLEL TO GRAIN**

SPECIES GROUPING	$C_{st}$
A	1.18
B	1.11
C	1.05
D	1.00

1994 UNIFORM BUILDING CODE

23-III-Y-23-III-Z

TABLE 23-III-AA—GEOMETRY FACTORS,  $C_{\Delta}$ , FOR SPLIT RING AND SHEAR PLATE CONNECTORS

		2 <sup>1</sup> / <sub>2</sub> -INCH (64 mm) SPLIT RING CONNECTORS AND 2 <sup>5</sup> / <sub>8</sub> -INCH (67 mm) SHEAR PLATE CONNECTORS				4-INCH (102 mm) SPLIT RING CONNECTORS AND 4-INCH (102 mm) SHEAR PLATE CONNECTORS			
		× 25.4 for mm							
		Parallel-to-Grain Loading		Perpendicular-to-Grain Loading		Parallel-to-Grain Loading		Perpendicular-to-Grain Loading	
		Minimum for Reduced Design Value	Minimum for Full Design Value	Minimum for Reduced Design Value	Minimum for Full Design Value	Minimum for Reduced Design Value	Minimum for Full Design Value	Minimum for Reduced Design Value	Minimum for Full Design Value
Edge distance	Unloaded edge $C_{\Delta}$	1 <sup>3</sup> / <sub>4</sub> " 1.0	1 <sup>3</sup> / <sub>4</sub> " 1.0	1 <sup>3</sup> / <sub>4</sub> " 1.0	1 <sup>3</sup> / <sub>4</sub> " 1.0	2 <sup>3</sup> / <sub>4</sub> " 1.0	2 <sup>3</sup> / <sub>4</sub> " 1.0	2 <sup>3</sup> / <sub>4</sub> " 1.0	2 <sup>3</sup> / <sub>4</sub> " 1.0
	Loaded edge $C_{\Delta}$	1 <sup>3</sup> / <sub>4</sub> " 1.0	1 <sup>3</sup> / <sub>4</sub> " 1.0	1 <sup>3</sup> / <sub>4</sub> " 0.83	2 <sup>3</sup> / <sub>4</sub> " 1.0	2 <sup>3</sup> / <sub>4</sub> " 1.0	2 <sup>3</sup> / <sub>4</sub> " 1.0	2 <sup>3</sup> / <sub>4</sub> " 0.83	3 <sup>3</sup> / <sub>4</sub> " 1.0
End distance	Tension member $C_{\Delta}$	2 <sup>3</sup> / <sub>4</sub> " 0.625	5 <sup>1</sup> / <sub>2</sub> " 1.0	2 <sup>3</sup> / <sub>4</sub> " 0.625	5 <sup>1</sup> / <sub>2</sub> " 1.0	3 <sup>1</sup> / <sub>2</sub> " 0.625	7" 1.0	3 <sup>1</sup> / <sub>2</sub> " 0.625	7" 1.0
	Compression member $C_{\Delta}$	2 <sup>1</sup> / <sub>2</sub> " 0.625	4" 1.0	2 <sup>3</sup> / <sub>4</sub> " 0.625	5 <sup>1</sup> / <sub>2</sub> " 1.0	3 <sup>1</sup> / <sub>4</sub> " 0.625	5 <sup>1</sup> / <sub>2</sub> " 1.0	3 <sup>1</sup> / <sub>2</sub> " 0.625	7" 1.0
Spacing	Parallel to grain $C_{\Delta}$	3 <sup>1</sup> / <sub>2</sub> " 0.5	6 <sup>3</sup> / <sub>4</sub> " 1.0	3 <sup>1</sup> / <sub>2</sub> " 1.0	3 <sup>1</sup> / <sub>2</sub> " 1.0	5" 0.5	9" 1.0	5" 1.0	5" 1.0
	Perpendicular to grain $C_{\Delta}$	3 <sup>1</sup> / <sub>2</sub> " 1.0	3 <sup>1</sup> / <sub>2</sub> " 1.0	3 <sup>1</sup> / <sub>2</sub> " 0.5	4 <sup>1</sup> / <sub>4</sub> " 1.0	5" 1.0	5" 1.0	5" 0.5	6" 1.0

TABLE 23-III-BB—DOWEL-BEARING STRENGTH FOR WOOD SCREW CONNECTIONS

SPECIES COMBINATION	SPECIFIC <sup>1</sup> GRAVITY, G	DOWEL-BEARING STRENGTH IN POUNDS PER SQUARE INCH (psi), $F_e$
		$\times 0.00689$ for N/mm <sup>2</sup>
Aspen	0.39	2,950
Balsam fir	0.36	2,550
Beech-birch-hickory	0.71	8,850
Coast sitka spruce	0.39	2,950
Cottonwood	0.41	3,200
Douglas fir-larch	0.50	4,650
Douglas fir-larch (north)	0.49	4,450
Douglas fir-south	0.46	4,000
Eastern hemlock	0.41	3,200
Eastern hemlock-tamarack	0.41	3,200
Eastern hemlock-tamarack (north)	0.47	4,150
Eastern softwoods	0.36	2,550
Eastern spruce	0.41	3,200
Eastern white pine	0.36	2,550
Engelmann spruce-lodgepole pine <sup>2</sup> (MSR 1650f and higher grades)	0.46	4,000
Engelmann spruce-lodgepole pine <sup>2</sup> (MSR 1500f and lower grades)	0.38	2,800
Hem-fir	0.43	3,500
Hem-fir (north)	0.46	4,000
Mixed maple	0.55	5,550
Mixed oak	0.68	8,150
Mixed southern pine	0.51	4,800
Mountain hemlock	0.47	4,150
Northern pine	0.42	3,350
Northern red oak	0.68	8,150
Northern species	0.35	2,400
Northern white cedar	0.31	1,900

(Continued)

TABLE 23-III-BB—DOWEL-BEARING STRENGTH FOR WOOD SCREW CONNECTIONS—(Continued)

SPECIES COMBINATION	SPECIFIC <sup>1</sup> GRAVITY, G	DOWEL-BEARING STRENGTH IN POUNDS PER SQUARE INCH (psi), $F_p$
		× 0.00689 for N/mm <sup>2</sup>
Ponderosa pine	0.43	3,500
Red maple	0.58	6,100
Red oak	0.67	7,950
Red pine	0.44	3,650
Redwood, close grain	0.44	3,650
Redwood, open grain	0.37	2,650
Sitka spruce	0.43	3,500
Southern pine	0.55	5,550
Spruce-pine-fir	0.42	3,350
Spruce-pine-fir (south)	0.36	2,550
Western cedars	0.36	2,550
Western cedars (north)	0.35	2,400
Western hemlock	0.47	4,150
Western hemlock (north)	0.46	4,000
Western white pine	0.40	3,100
Western woods	0.36	2,550
White oak	0.73	9,300
Yellow poplar	0.43	3,500

<sup>1</sup>Specific gravity based on weight and volume when oven dry.

<sup>2</sup>Applies only to Engelmann spruce-lodgepole pine machine stress-rated (MSR) structural lumber.

**TABLE 23-III-CC—CUT THREAD OR ROLLED THREAD WOOD SCREW WITHDRAWAL DESIGN VALUES (W)<sup>1</sup>**  
 Tabulated withdrawal design values (W) are in pounds per inch (N/mm) of thread penetration into side grain of main member.  
 Thread length is approximately two thirds the total wood screw length.

SPECIFIC GRAVITY, G	WOOD SCREW GAGE × 0.175 for N/mm										
	6d	7d	8d	9d	10d	12d	14d	16d	18d	20d	24d
0.73	209	229	249	268	288	327	367	406	446	485	564
0.71	198	216	235	254	272	310	347	384	421	459	533
0.68	181	199	216	233	250	284	318	352	387	421	489
0.67	176	193	209	226	243	276	309	342	375	409	475
0.58	132	144	157	169	182	207	232	256	281	306	356
0.55	119	130	141	152	163	186	208	231	253	275	320
0.51	102	112	121	131	141	160	179	198	217	237	275
0.50	98	107	117	126	135	154	172	191	209	228	264
0.49	94	103	112	121	130	147	165	183	201	219	254
0.47	87	95	103	111	119	136	152	168	185	201	234
0.46	83	91	99	107	114	130	146	161	177	193	224
0.44	76	83	90	97	105	119	133	148	162	176	205
0.43	73	79	86	93	100	114	127	141	155	168	196
0.42	69	76	82	89	95	108	121	134	147	161	187
0.41	66	72	78	85	91	103	116	128	141	153	178
0.40	63	69	75	81	86	98	110	122	134	146	169
0.39	60	65	71	77	82	93	105	116	127	138	161
0.38	57	62	67	73	78	89	99	110	121	131	153
0.37	54	59	64	69	74	84	94	104	114	125	145
0.36	51	56	60	65	70	80	89	99	108	118	137
0.35	48	53	57	62	66	75	84	93	102	111	130
0.31	38	41	45	48	52	59	66	73	80	87	102

<sup>1</sup>Tabulated withdrawal design values (W) for wood screw connections shall be multiplied by all applicable adjustment factors (see Table 23-III-A).

TABLE 23-III-DD—CUT THREAD WOOD SCREW DESIGN VALUES (Z)<sup>1,2</sup>  
FOR SINGLE SHEAR (Two-member) CONNECTIONS WITH BOTH MEMBERS OF IDENTICAL SPECIES

SIDE MEMBER THICKNESS $t_e$ inches	WOOD SCREW DIAMETER $D$ inches	WOOD SCREW GAGE	$G = 0.67$	$G = 0.55$	$G = 0.50$	$G = 0.49$	$G = 0.46$
			RED OAK	MIXED MAPLE SOUTHERN PINE	DOUGLAS FIR- LARCH	DOUGLAS FIR-LARCH (N)	DOUGLAS FIR (S) HEM-FIR (N)
			Z lbs.	Z lbs.	Z lbs.	Z lbs.	Z lbs.
× 25.4 for mm			× 4.45 for N				
1/2	0.138	6d	111	85	75	73	68
	0.151	7d	123	95	84	82	76
	0.164	8d	140	108	96	94	88
	0.177	9d	152	119	107	104	97
	0.190	10d	156	122	109	106	100
	0.216	12d	173	138	124	121	114
	0.242	14d	183	146	132	128	121
	0.268	16d	212	171	155	151	143
0.294	18d	235	190	172	168	159	
5/8	0.138	6d	127	95	83	80	74
	0.151	7d	140	105	92	89	83
	0.164	8d	157	119	105	101	94
	0.177	9d	170	130	114	111	103
	0.190	10d	173	133	117	114	106
	0.216	12d	189	147	131	127	119
	0.242	14d	198	155	138	134	125
	0.268	16d	227	179	161	156	147
0.294	18d	252	199	178	174	163	

3/4	0.138	6d	132	106	92	88	81
	0.151	7d	150	117	102	98	90
	0.164	8d	177	132	114	111	102
	0.177	9d	190	142	124	120	111
	0.190	10d	193	145	127	123	114
	0.216	12d	208	159	140	135	126
	0.242	14d	217	166	146	142	132
	0.268	16d	246	190	169	164	153
	0.294	18d	272	210	187	182	170
	0.320	20d	310	242	216	210	197
0.372	24d	362	283	252	246	230	
1	0.138	6d	132	110	101	99	93
	0.151	7d	150	125	115	112	106
	0.164	8d	177	148	135	132	121
	0.177	9d	199	167	147	142	130
	0.190	10d	205	171	150	144	132
	0.216	12d	239	186	161	156	143
	0.242	14d	256	193	168	162	150
	0.268	16d	290	217	190	184	170
	0.294	18d	320	240	210	203	188
	0.320	20d	359	272	239	232	215
0.372	24d	419	317	279	270	251	

(Continued)

TABLE 23-III-DD—CUT THREAD WOOD SCREW DESIGN VALUES (Z)<sup>1,2</sup>  
FOR SINGLE SHEAR (Two-member) CONNECTIONS WITH BOTH MEMBERS OF IDENTICAL SPECIES—(Continued)

SIDE MEMBER THICKNESS $t_s$ inches	WOOD SCREW DIAMETER $D$ inches	WOOD SCREW GAGE	$G = 0.67$	$G = 0.55$	$G = 0.50$	$G = 0.49$	$G = 0.46$
			RED OAK	MIXED MAPLE SOUTHERN PINE	DOUGLAS FIR- LARCH	DOUGLAS FIR-LARCH (N)	DOUGLAS FIR (S) HEM-FIR (N)
			Z	Z	Z	Z	Z
			lbs.	lbs.	lbs.	lbs.	lbs.
× 25.4 for mm			× 4.45 for N				
1 <sup>1</sup> / <sub>4</sub>	0.138	6d	132	110	101	99	93
	0.151	7d	150	125	115	112	106
	0.164	8d	177	148	135	132	125
	0.177	9d	199	167	152	149	141
	0.190	10d	205	171	157	153	145
	0.216	12d	239	200	183	179	164
	0.242	14d	256	213	193	186	170
	0.268	16d	305	249	215	208	191
	0.294	18d	340	275	238	229	211
	0.320	20d	403	308	268	259	238
	0.372	24d	471	359	312	302	278
1 <sup>1</sup> / <sub>2</sub>	0.138	6d	132	110	101	99	93
	0.151	7d	150	125	115	112	106
	0.164	8d	177	148	135	132	125
	0.177	9d	199	167	152	149	141
	0.190	10d	205	171	157	153	145
	0.216	12d	239	200	183	179	169
	0.242	14d	256	213	195	191	181
	0.268	16d	305	255	233	228	214
	0.294	18d	340	284	260	254	236
	0.320	20d	403	336	300	289	265
	0.372	24d	471	394	349	337	309

<sup>1</sup>Tabulated lateral design values (Z) for wood screw connections shall be multiplied by all applicable adjustment factors (see Table 23-III-A).

<sup>2</sup>Tabulated lateral design values (Z) are for cut thread wood screws inserted in side grain with wood screw axis perpendicular to wood fibers, and with the following wood screw bending yield strength ( $F_{yb}$ ):

$F_{yb} = 100,000$  psi (690 N/mm<sup>2</sup>) for 6d wood screws.

$F_{yb} = 90,000$  psi (620 N/mm<sup>2</sup>) for 7d, 8d and 9d wood screws.

$F_{yb} = 80,000$  psi (551 N/mm<sup>2</sup>) for 10d and 12d wood screws.

$F_{yb} = 70,000$  psi (482 N/mm<sup>2</sup>) for 14d and 16d wood screws.

$F_{yb} = 60,000$  psi (413 N/mm<sup>2</sup>) for 18d and 20d wood screws.

$F_{yb} = 45,000$  psi (310 N/mm<sup>2</sup>) for 24d wood screws.

(Table continues)

SIDE MEMBER THICKNESS $t$ Inches	WOOD SCREW DIAMETER $D$ Inches	WOOD SCREW GAGE	G = 0.43	G = 0.42	G = 0.37	G = 0.36	G = 0.35
			HEM-FIR	SPRUCE-PINE-FIR	REDWOOD (open grain)	EASTERN SOFTWOODS SPRUCE-PINE-FIR(S) WESTERN CEDARS WESTERN WOODS	NORTHERN SPECIES
× 25.4 for mm			Z lbs.	Z lbs.	Z lbs.	Z lbs.	Z lbs.
			× 4.45 for N				
1/2	0.138	6d	62	60	52	51	49
	0.151	7d	70	68	59	58	56
	0.164	8d	81	79	68	67	65
	0.177	9d	90	87	77	75	72
	0.190	10d	92	90	79	77	74
	0.216	12d	105	103	91	89	86
	0.242	14d	112	110	97	95	92
	0.268	16d	133	130	115	113	107
	0.294	18d	148	145	128	125	118
5/8	0.138	6d	67	65	55	54	52
	0.151	7d	75	73	62	61	58
	0.164	8d	86	83	72	70	67
	0.177	9d	95	92	79	78	75
	0.190	10d	97	94	81	79	77
	0.216	12d	109	106	93	91	88
	0.242	14d	116	113	99	96	93
	0.268	16d	136	132	116	114	110
	0.294	18d	151	147	129	127	123

(Continued)

TABLE 23-III-DD—CUT THREAD WOOD SCREW DESIGN VALUES (Z)<sup>1,2</sup>  
 FOR SINGLE SHEAR (Two-member) CONNECTIONS WITH BOTH MEMBERS OF IDENTICAL SPECIES—(Continued)

SIDE MEMBER THICKNESS $t_s$ inches	WOOD SCREW DIAMETER $D$ inches	WOOD SCREW GAGE	G = 0.43	G = 0.42	G = 0.37	G = 0.36	G = 0.35
			HEM-FIR	SPRUCE-PINE-FIR	REDWOOD (open grain)	EASTERN SOFTWOODS SPRUCE-PINE-FIR(S) WESTERN CEDARS WESTERN WOODS	NORTHERN SPECIES
			Z lbs.	Z lbs.	Z lbs.	Z lbs.	Z lbs.
× 25.4 for mm			× 4.45 for N				
3/4	0.138	6d	73	71	60	58	55
	0.151	7d	82	79	67	65	62
	0.164	8d	92	90	76	74	71
	0.177	9d	101	98	83	81	78
	0.190	10d	103	100	85	83	80
	0.216	12d	115	112	96	94	90
	0.242	14d	121	118	102	99	96
	0.268	16d	141	137	119	116	112
	0.294	18d	156	152	132	129	125
	0.320	20d	182	177	155	152	147
0.372	24d	212	207	181	177	171	
1	0.138	6d	87	84	69	67	64
	0.151	7d	97	93	77	75	71
	0.164	8d	108	104	87	84	80
	0.177	9d	117	113	94	91	87
	0.190	10d	119	115	96	93	89
	0.216	12d	129	125	106	103	99
	0.242	14d	135	131	111	108	104
	0.268	16d	154	150	128	124	120
	0.294	18d	171	166	141	138	133
	0.320	20d	196	190	163	160	154
0.372	24d	229	222	191	186	179	

1 <sup>1/4</sup>	0.138	6d	87	86	76	75	72
	0.151	7d	99	97	86	85	82
	0.164	8d	117	115	99	96	92
	0.177	9d	132	129	107	104	99
	0.190	10d	136	132	109	106	101
	0.216	12d	147	142	118	114	109
	0.242	14d	153	147	123	119	114
	0.268	16d	172	166	139	135	130
	0.294	18d	190	184	154	150	144
	0.320	20d	215	208	176	171	164
0.372	24d	251	243	206	200	192	
1 <sup>1/2</sup>	0.138	6d	87	86	76	75	72
	0.151	7d	99	97	86	85	82
	0.164	8d	117	115	102	100	97
	0.177	9d	132	129	115	113	110
	0.190	10d	136	133	118	116	113
	0.216	12d	159	155	132	127	121
	0.242	14d	170	166	137	132	126
	0.268	16d	192	185	153	149	142
	0.294	18d	212	204	169	164	157
	0.320	20d	238	230	191	186	178
0.372	24d	277	268	223	217	207	

<sup>1</sup>Tabulated lateral design values (Z) for wood screw connections shall be multiplied by all applicable adjustment factors (see Table 23-III-A).

<sup>2</sup>Tabulated lateral design values (Z) are for cut thread wood screws inserted in side grain with wood screw axis perpendicular to wood fibers, and with the following wood screw bending yield strength ( $F_{yb}$ ):

$F_{yb} = 100,000$  psi (690 N/mm<sup>2</sup>) for 6d wood screws.

$F_{yb} = 90,000$  psi (620 N/mm<sup>2</sup>) for 7d, 8d and 9d wood screws.

$F_{yb} = 80,000$  psi (551 N/mm<sup>2</sup>) for 10d and 12d wood screws.

$F_{yb} = 70,000$  psi (482 N/mm<sup>2</sup>) for 14d and 16d wood screws.

$F_{yb} = 60,000$  psi (413 N/mm<sup>2</sup>) for 18d and 20d wood screws.

$F_{yb} = 45,000$  psi (310 N/mm<sup>2</sup>) for 24d wood screws.

TABLE 23-III-EE—CUT THREAD WOOD SCREW DESIGN VALUES (Z)<sup>1,2,3</sup>  
FOR SINGLE SHEAR (Two-member) CONNECTIONS WITH ASTM A 446, GRADE A STEEL SIDE PLATE

STEEL SIDE PLATE	WOOD SCREW DIAMETER D inches	WOOD SCREW GAGE	G = 0.67	G = 0.55	G = 0.50	G = 0.49	G = 0.46
			RED OAK	MIXED MAPLE SOUTHERN PINE	DOUGLAS FIR-LARCH	DOUGLAS FIR-LARCH (N)	DOUGLAS FIR (S) HEM-FIR (N)
			Z	Z	Z	Z	Z
			lbs.	lbs.	lbs.	lbs.	lbs.
× 25.4 for mm			× 4.45 for N				
3 gage $t_s=0.239''$	0.242	14d	276	241	225	221	211
	0.268	16d	315	275	256	252	241
	0.294	18d	349	304	283	278	267
	0.320	20d	400	348	325	319	305
	0.372	24d	467	407	379	372	356
7 gage $t_s=0.179''$	0.190	10d	210	184	171	168	161
	0.216	12d	234	204	190	186	178
	0.242	14d	247	215	200	196	188
	0.268	16d	286	248	231	227	217
	0.294	18d	318	276	256	252	241
	0.320	20d	369	320	297	292	279
	0.372	24d	431	374	347	341	326
10 gage $t_s=0.134''$	0.138	6d	131	114	107	105	100
	0.151	7d	147	128	119	117	112
	0.164	8d	169	147	137	134	129
	0.177	9d	187	162	151	148	142
	0.190	10d	192	166	155	152	145
	0.216	12d	217	188	175	172	164
	0.242	14d	230	199	185	182	174
	0.268	16d	271	234	217	213	204
	0.294	18d	301	260	241	237	226
	0.320	20d	353	304	282	277	265
	0.372	24d	413	356	330	324	309

11 gage $t_s=0.12''$	0.138	6d	127	110	103	101	96
	0.151	7d	142	124	115	113	108
	0.164	8d	164	143	133	130	125
	0.177	9d	182	158	147	144	138
	0.190	10d	187	162	151	148	141
	0.216	12d	213	184	171	168	160
	0.242	14d	226	196	182	178	170
	0.268	16d	267	230	214	210	200
	0.294	18d	297	256	238	233	223
	0.320	20d	349	301	279	274	261
0.372	24d	408	352	326	320	306	
12 gage $t_s=0.105''$	0.138	6d	122	106	99	97	93
	0.151	7d	138	119	111	109	104
	0.164	8d	160	138	129	126	121
	0.177	9d	178	154	143	140	134
	0.190	10d	183	158	147	144	138
	0.216	12d	209	181	168	165	157
	0.242	14d	223	192	178	175	167
	0.268	16d	264	227	211	207	197
	0.294	18d	294	253	234	230	219
	0.320	20d	346	298	276	271	258
0.372	24d	405	348	323	317	302	

(Continued)

**TABLE 23-III-EE—CUT THREAD WOOD SCREW DESIGN VALUES (Z)<sup>1,2,3</sup>**  
**FOR SINGLE SHEAR (Two-member) CONNECTIONS WITH ASTM A 446, GRADE A STEEL SIDE PLATE—(Continued)**

STEEL SIDE PLATE	WOOD SCREW DIAMETER <i>D</i> inches	WOOD SCREW GAGE	<i>G</i> = 0.67	<i>G</i> = 0.55	<i>G</i> = 0.50	<i>G</i> = 0.49	<i>G</i> = 0.46
			RED OAK	MIXED MAPLE SOUTHERN PINE	DOUGLAS FIR-LARCH	DOUGLAS FIR-LARCH (N)	DOUGLAS FIR (S) HEM-FIR (N)
			Z	Z	Z	Z	Z
			lbs.	lbs.	lbs.	lbs.	lbs.
× 25.4 for mm			× 4.45 for N				
14 gage <i>t<sub>s</sub></i> = 0.075"	0.138	6d	116	100	93	91	87
	0.151	7d	131	113	105	103	98
	0.164	8d	153	132	122	120	115
	0.177	9d	172	148	137	135	128
	0.190	10d	177	152	141	138	132
	0.216	12d	205	176	163	160	152
	0.242	14d	219	188	174	170	163
	0.268	16d	261	223	207	203	193
	0.294	18d	290	249	230	226	215
16 gage <i>t<sub>s</sub></i> = 0.06"	0.138	6d	114	98	90	89	85
	0.151	7d	129	111	103	101	96
	0.164	8d	151	130	120	118	113
	0.177	9d	171	146	135	133	127
	0.190	10d	175	150	139	136	130
18 gage <i>t<sub>s</sub></i> = 0.048"	0.138	6d	113	97	89	88	84
	0.151	7d	128	110	101	99	95
	0.164	8d	151	129	119	117	112

<sup>1</sup>Tabulated lateral design values (Z) for wood screw connections shall be multiplied by all applicable adjustment factors (see Table 23-III-A).

<sup>2</sup>Tabulated lateral design values (Z) are for cut thread wood screws inserted in side grain with wood screw axis perpendicular to wood fibers, and with the following wood screw bending yield strength ( $F_{yb}$ ):

$F_{yb} = 100,000$  psi (690 N/mm<sup>2</sup>) for 6d wood screws.

$F_{yb} = 90,000$  psi (621 N/mm<sup>2</sup>) for 7d, 8d and 9d wood screws.

$F_{yb} = 80,000$  psi (552 N/mm<sup>2</sup>) for 10d and 12d wood screws.

$F_{yb} = 70,000$  psi (483 N/mm<sup>2</sup>) for 14d and 16d wood screws.

$F_{yb} = 60,000$  psi (414 N/mm<sup>2</sup>) for 18d and 20d wood screws.

$F_{yb} = 45,000$  psi (310 N/mm<sup>2</sup>) for 24d wood screws.

<sup>3</sup>Tabulated lateral design values (Z) are based on a dowel bearing strength ( $F_e$ ) of 45,000 psi (310 N/mm<sup>2</sup>) for ASTM A 446, Grade A steel.

(Table continues)

STEEL SIDE PLATE	WOOD SCREW DIAMETER D Inches	WOOD SCREW GAGE	G = 0.43	G = 0.42	G = 0.37	G = 0.36	G = 0.35
			HEM-FIR	SPRUCE-PINE-FIR	REDWOOD (open grain)	EASTERN SOFTWOODS SPRUCE-PINE-FIR (S) WESTERN CEDARS WESTERN WOODS	NORTHERN SPECIES
× 25.4 for mm			Z lbs.	Z lbs.	Z lbs.	Z lbs.	Z lbs.
			× 4.45 for N				
3 gage $t_s=0.239"$	0.242	14d	200	197	178	175	171
	0.268	16d	228	224	203	199	194
	0.294	18d	252	248	224	221	215
	0.320	20d	289	283	257	252	246
	0.372	24d	337	331	299	294	287
7 gage $t_s=0.179"$	0.190	10d	152	150	135	133	130
	0.216	12d	169	166	150	147	144
	0.242	14d	178	174	158	155	151
	0.268	16d	205	201	182	179	174
	0.294	18d	228	223	202	199	193
	0.320	20d	264	259	234	230	224
	0.372	24d	308	302	273	268	261
10 gage $t_s=0.134"$	0.138	6d	95	93	84	83	81
	0.151	7d	106	104	94	93	90
	0.164	8d	122	119	108	106	103
	0.177	9d	134	132	119	117	114
	0.190	10d	137	135	122	120	117
	0.216	12d	155	152	137	135	131
	0.242	14d	164	161	145	143	139
	0.268	16d	192	188	170	167	163
	0.294	18d	213	209	189	186	181
	0.320	20d	250	245	221	217	211
	0.372	24d	292	286	258	254	247

(Continued)

TABLE 23-III-EE—CUT THREAD WOOD SCREW DESIGN VALUES (Z)<sup>1,2,3</sup>  
 FOR SINGLE SHEAR (Two-member) CONNECTIONS WITH ASTM A 446, GRADE A STEEL SIDE PLATE—(Continued)

STEEL SIDE PLATE	WOOD SCREW DIAMETER D inches	WOOD SCREW GAGE	G = 0.43	G = 0.42	G = 0.37	G = 0.36	G = 0.35
			HEM-FIR	SPRUCE-PINE-FIR	REDWOOD (open grain)	EASTERN SOFTWOODS SPRUCE-PINE-FIR (S) WESTERN CEDARS WESTERN WOODS	NORTHERN SPECIES
			Z lbs.	Z lbs.	Z lbs.	Z lbs.	Z lbs.
× 25.4 for mm			× 4.45 for N				
11 gage <i>t<sub>s</sub></i> = 0.12"	0.138	6d	91	89	81	80	77
	0.151	7d	102	100	91	89	87
	0.164	8d	118	115	104	103	100
	0.177	9d	130	128	115	113	110
	0.190	10d	133	131	118	116	113
	0.216	12d	152	149	134	132	128
	0.242	14d	161	158	142	140	136
	0.268	16d	189	185	167	164	160
	0.294	18d	210	206	186	182	177
	0.320	20d	246	242	218	214	208
0.372	24d	288	283	254	250	243	
12 gage <i>t<sub>s</sub></i> = 0.105"	0.138	6d	88	86	78	76	74
	0.151	7d	98	97	87	86	84
	0.164	8d	114	112	101	99	97
	0.177	9d	127	124	112	110	107
	0.190	10d	130	127	115	113	110
	0.216	12d	148	145	131	129	125
	0.242	14d	158	155	139	137	133
	0.268	16d	186	182	164	161	157
	0.294	18d	207	203	183	179	175
	0.320	20d	243	239	215	211	205
0.372	24d	285	279	251	247	240	

14 gage $t_s=0.075''$	0.138	6d	82	80	72	71	69
	0.151	7d	92	91	82	80	78
	0.164	8d	108	106	95	94	91
	0.177	9d	121	119	107	105	102
	0.190	10d	124	122	110	108	105
	0.216	12d	144	141	127	124	121
	0.242	14d	153	150	135	133	129
	0.268	16d	182	178	160	157	153
0.294	18d	203	199	178	175	170	
16 gage $t_s=0.06''$	0.138	6d	80	78	70	69	67
	0.151	7d	90	89	80	78	76
	0.164	8d	106	104	93	92	89
	0.177	9d	119	117	105	103	100
	0.190	10d	122	120	108	106	103
18 gage $t_s=0.048''$	0.138	6d	79	77	69	68	66
	0.151	7d	89	88	79	77	75
	0.164	8d	105	103	92	91	88

<sup>1</sup>Tabulated lateral design values (Z) for wood screw connections shall be multiplied by all applicable adjustment factors (see Table 23-III-A).

<sup>2</sup>Tabulated lateral design values (Z) are for cut thread wood screws inserted in side grain with wood screw axis perpendicular to wood fibers, and with the following wood screw bending yield strength ( $F_{yb}$ ):

$F_{yb} = 100,000$  psi (690 N/mm<sup>2</sup>) for 6d wood screws.

$F_{yb} = 70,000$  psi (483 N/mm<sup>2</sup>) for 14d and 16d wood screws.

$F_{yb} = 90,000$  psi (621 N/mm<sup>2</sup>) for 7d, 8d and 9d wood screws.

$F_{yb} = 60,000$  psi (414 N/mm<sup>2</sup>) for 18d and 20d wood screws.

$F_{yb} = 80,000$  psi (552 N/mm<sup>2</sup>) for 10d and 12d wood screws.

$F_{yb} = 45,000$  psi (310 N/mm<sup>2</sup>) for 24d wood screws.

<sup>3</sup>Tabulated lateral design values (Z) are based on a dowel-bearing strength ( $F_e$ ) of 45,000 psi (310 N/mm<sup>2</sup>) for ASTM A 446, Grade A steel.

TABLE 23-III-FF—DOWEL-BEARING STRENGTH FOR NAIL OR SPIKE CONNECTIONS

SPECIES COMBINATION	SPECIFIC <sup>1</sup> GRAVITY, G	DOWEL-BEARING STRENGTH IN POUNDS PER SQUARE INCH (psi), $F_e$	
		× 0.00689 for N/mm <sup>2</sup>	
Aspen	0.39	2,950	
Balsam fir	0.36	2,550	
Beech-birch-hickory	0.71	8,850	
Coast sitka spruce	0.39	2,950	
Cottonwood	0.41	3,200	
Douglas fir-larch	0.50	4,650	
Douglas fir-larch (north)	0.49	4,450	
Douglas fir-south	0.46	4,000	
Eastern hemlock	0.41	3,200	
Eastern hemlock-tamarack	0.41	3,200	
Eastern hemlock-tamarack (north)	0.47	4,150	
Eastern softwoods	0.36	2,550	
Eastern spruce	0.41	3,200	
Eastern white pine	0.36	2,550	
Engelmann spruce-lodgepole pine <sup>2</sup> (MSR 1650f and higher grades)	0.46	4,000	
Engelmann spruce-lodgepole pine <sup>2</sup> (MSR 1500f and lower grades)	0.38	2,800	
Hem-fir	0.43	3,500	
Hem-fir (north)	0.46	4,000	
Mixed maple	0.55	5,550	
Mixed oak	0.68	8,150	
Mixed southern pine	0.51	4,800	
Mountain hemlock	0.47	4,150	
Northern pine	0.42	3,350	
Northern red oak	0.68	8,150	
Northern species	0.35	2,400	
Northern white cedar	0.31	1,900	

2-1052

23-III-FF

1994 UNIFORM BUILDING CODE

Ponderosa pine	0.43	3,500
Red maple	0.58	6,100
Red oak	0.67	7,950
Red pine	0.44	3,650
Redwood, close grain	0.44	3,650
Redwood, open grain	0.37	2,650
Sitka spruce	0.43	3,500
Southern pine	0.55	5,550
Spruce-pine-fir	0.42	3,350
Spruce-pine-fir (south)	0.36	2,550
Western cedars	0.36	2,550
Western cedars (north)	0.35	2,400
Western hemlock	0.47	4,150
Western hemlock (north)	0.46	4,000
Western white pine	0.40	3,100
Western woods	0.36	2,550
White oak	0.73	9,300
Yellow poplar	0.43	3,500

<sup>1</sup>Specific gravity based on weight and volume when oven dry.

<sup>2</sup>Applies only to Engelmann spruce-lodgepole pine machine stress-rated (MSR) structural lumber.

TABLE 23-III-GG—NAIL AND SPIKE WITHDRAWAL DESIGN VALUES (W)<sup>1</sup>

Tabulated withdrawal design values (W) are in pounds per inch (N/mm) of penetration into side grain of main member.

SPECIFIC GRAVITY G	COMMON WIRE NAILS, BOX NAILS, AND COMMON WIRE SPIKES															THREADED NAILS				
	Diameter, D																			
	× 25.4 for mm															Wire Diameter, D				
	0.099"	0.113"	0.128"	0.131"	0.135"	0.148"	0.162"	0.192"	0.207"	0.225"	0.244"	0.263"	0.283"	0.312"	0.375"	0.12"	0.135"	0.148"	0.177"	0.207"
× 0.175 for N/mm																				
0.73	62	71	80	82	85	93	102	121	130	141	153	165	178	196	236	82	93	102	121	141
0.71	58	66	75	77	79	87	95	113	121	132	143	154	166	183	220	77	87	95	113	132
0.68	52	59	67	69	71	78	85	101	109	118	128	138	149	164	197	69	78	85	101	118
0.67	50	57	65	66	68	75	82	97	105	114	124	133	144	158	190	66	75	82	97	114
0.58	35	40	45	46	48	52	57	68	73	80	86	93	100	110	133	46	52	57	68	80
0.55	31	35	40	41	42	46	50	59	64	70	76	81	88	97	116	41	46	50	59	70
0.51	25	29	33	34	35	38	42	49	53	58	63	67	73	80	96	34	38	42	49	58
0.50	24	28	31	32	33	36	40	47	50	55	60	64	69	76	91	32	36	40	47	55
0.49	23	26	30	30	31	34	38	45	48	52	57	61	66	72	87	30	34	38	45	52
0.47	21	24	27	27	28	31	34	40	43	47	51	55	59	65	78	27	31	34	40	47
0.46	20	22	25	26	27	29	32	38	41	45	48	52	56	62	74	26	29	32	38	45
0.44	18	20	23	23	24	26	29	34	37	40	43	47	50	55	66	23	26	29	34	40
0.43	17	19	21	22	23	25	27	32	35	38	41	44	47	52	63	22	25	27	32	38
0.42	16	18	20	21	21	23	26	30	33	35	38	41	45	49	59	21	23	26	30	35
0.41	15	17	19	19	20	22	24	29	31	33	36	39	42	46	56	19	22	24	29	33
0.40	14	16	18	18	19	21	23	27	29	31	34	37	40	44	52	18	21	23	27	31
0.39	13	15	17	17	18	19	21	25	27	29	32	34	37	41	49	17	19	21	25	29
0.38	12	14	16	16	17	18	20	24	25	28	30	32	35	38	46	16	18	20	24	28
0.37	11	13	15	15	16	17	19	22	24	26	28	30	33	36	43	15	17	19	22	26
0.36	11	12	14	14	14	16	17	21	22	24	26	28	30	33	40	14	16	17	21	24
0.35	10	11	13	13	14	15	16	19	21	23	24	26	28	31	38	13	15	16	19	23
0.31	7	8	9	10	10	11	12	14	15	17	18	19	21	23	28	10	11	12	14	17

<sup>1</sup>Tabulated withdrawal design values (W) for wood screw connections shall be multiplied by all applicable adjustment factors (see Table 23-III-A).

**TABLE 23-III-HH—BOX NAIL DESIGN VALUES (Z) FOR SINGLE SHEAR (Two-member) CONNECTIONS<sup>1,2</sup>  
WITH BOTH MEMBERS OF IDENTICAL SPECIES**

SIDE MEMBER THICKNESS $t_s$ inches	NAIL LENGTH $L$ inches	NAIL DIAMETER $D$ inches		G = 0.67	G = 0.55	G = 0.50	G = 0.49	G = 0.46
				RED OAK	MIXED MAPLE SOUTHERN PINE	DOUGLAS FIR- LARCH	DOUGLAS FIR- LARCH (N)	DOUGLAS FIR (S) HEM-FIR (N)
				Z	Z	Z	Z	Z
				lbs.	lbs.	lbs.	lbs.	lbs.
$\times 25.4$ for mm			PENNYWEIGHT	$\times 4.45$ for N				
1/2	2	0.099	6d	73	55	48	47	43
	2 1/2	0.113	8d	88	67	59	57	53
	3	0.128	10d	106	82	73	71	66
	3 1/4	0.128	12d	106	82	73	71	66
	3 1/2	0.135	16d	115	89	79	77	72
	4	0.148	20d	129	101	90	87	82
	4 1/2	0.148	30d	129	101	90	87	82
	5	0.162	40d	149	117	105	102	96
5/8	2	0.099	6d	73	61	55	53	48
	2 1/2	0.113	8d	94	76	66	64	59
	3	0.128	10d	120	91	79	77	71
	3 1/4	0.128	12d	120	91	79	77	71
	3 1/2	0.135	16d	130	98	86	84	78
	4	0.148	20d	144	110	97	94	87
	4 1/2	0.148	30d	144	110	97	94	87
	5	0.162	40d	165	126	112	109	101
3/4	2	0.099	6d	73	61	55	54	51
	2 1/2	0.113	8d	94	79	72	71	65
	3	0.128	10d	121	101	87	84	78
	3 1/4	0.128	12d	121	101	87	84	78
	3 1/2	0.135	16d	135	108	94	91	84
	4	0.148	20d	154	121	105	102	94
	4 1/2	0.148	30d	154	121	105	102	94
	5	0.162	40d	183	138	121	117	108

(Continued)

**TABLE 23-III-HH—BOX NAIL DESIGN VALUES (Z) FOR SINGLE SHEAR (Two-member) CONNECTIONS<sup>1,2</sup>  
WITH BOTH MEMBERS OF IDENTICAL SPECIES—(Continued)**

SIDE MEMBER THICKNESS $t_s$ inches	NAIL LENGTH $L$ inches	NAIL DIAMETER $D$ inches	PENNYWEIGHT	G = 0.67	G = 0.55	G = 0.50	G = 0.49	G = 0.46
				RED OAK	MIXED MAPLE SOUTHERN PINE	DOUGLAS FIR- LARCH	DOUGLAS FIR- LARCH (N)	DOUGLAS FIR (S) HEM-FIR (N)
				Z	Z	Z	Z	Z
				lbs.	lbs.	lbs.	lbs.	lbs.
× 25.4 for mm				× 4.45 for N				
1	2 1/2	0.113	8d	94	79	72	71	67
	3	0.128	10d	121	101	93	91	86
	3 1/4	0.128	12d	121	101	93	91	86
	3 1/2	0.135	16d	135	113	103	101	96
	4	0.148	20d	154	128	118	115	109
	4 1/2	0.148	30d	154	128	118	115	109
1 1/4	5	0.162	40d	184	154	141	137	125
	3	0.128	10d	121	101	93	91	86
	3 1/4	0.128	12d	121	101	93	91	86
	3 1/2	0.135	16d	135	113	103	101	96
	4	0.148	20d	154	128	118	115	109
1 1/2	4 1/2	0.148	30d	154	128	118	115	109
	5	0.162	40d	184	154	141	138	131
	3 1/4	0.128	12d	121	101	93	91	86
	3 1/2	0.135	16d	135	113	103	101	96
1 1/2	4	0.148	20d	154	128	118	115	109
	4 1/2	0.148	30d	154	128	118	115	109
	5	0.162	40d	184	154	141	138	131

<sup>1</sup>Tabulated lateral design values (Z) for nailed connections shall be multiplied by all applicable adjustment factors (see Table 23-III-A).

<sup>2</sup>Tabulated lateral design values (Z) are for box nails inserted in side grain with nail axis perpendicular to wood fibers, and with the following nail bending yield strength ( $F_{yb}$ ):  
 $F_{yb}$  = 100,000 psi (690 N/mm<sup>2</sup>) for 0.099-inch- (2.5 mm), 0.113-inch- (2.9 mm), 0.128-inch- (3.3 mm) and 0.135-inch-diameter (3.4 mm) box nails.  
 $F_{yb}$  = 90,000 psi (621 N/mm<sup>2</sup>) for 0.148-inch- (3.8 mm) and 0.162-inch-diameter (4.1 mm) box nails.

(Table continues)

SIDE MEMBER THICKNESS $t$ inches	NAIL LENGTH $L$ inches	NAIL DIAMETER $D$ inches	PENNYWEIGHT	G = 0.43	G = 0.42	G = 0.37	G = 0.36	G = 0.35
				HEM-FIR	SPRUCE-PINE-FIR	REDWOOD (open grain)	EASTERN SOFTWOODS SPRUCE-PINE-FIR(S) WESTERN CEDARS WESTERN WOODS	NORTHERN SPECIES
× 25.4 for mm			× 4.45 for N					
				Z lbs.	Z lbs.	Z lbs.	Z lbs.	Z lbs.
1/2	2	0.099	6d	39	38	33	32	31
	2 1/2	0.113	8d	49	47	41	40	38
	3	0.128	10d	61	59	51	50	48
	3 1/4	0.128	12d	61	59	51	50	48
	3 1/2	0.135	16d	66	65	56	55	53
	4	0.148	20d	75	73	64	63	61
	4 1/2	0.148	30d	75	73	64	63	61
5	0.162	40d	89	87	76	74	72	
5/8	2	0.099	6d	44	42	35	34	33
	2 1/2	0.113	8d	53	52	44	43	41
	3	0.128	10d	65	63	54	53	51
	3 1/4	0.128	12d	65	63	54	53	51
	3 1/2	0.135	16d	71	69	59	58	55
	4	0.148	20d	80	77	67	65	63
	4 1/2	0.148	30d	80	77	67	65	63
5	0.162	40d	93	90	78	77	74	
3/4	2	0.099	6d	48	47	39	38	36
	2 1/2	0.113	8d	58	57	47	46	44
	3	0.128	10d	70	68	57	56	54
	3 1/4	0.128	12d	70	68	57	56	54
	3 1/2	0.135	16d	76	74	63	61	58
	4	0.148	20d	85	83	70	69	66
	4 1/2	0.148	30d	85	83	70	69	66
5	0.162	40d	99	96	82	80	77	

(Continued)

TABLE 23-III-HH—BOX NAIL DESIGN VALUES (Z) FOR SINGLE SHEAR (Two-member) CONNECTIONS<sup>1,2</sup>  
WITH BOTH MEMBERS OF IDENTICAL SPECIES—(Continued)

SIDE MEMBER THICKNESS $t_s$ inches	NAIL LENGTH $L$ inches	NAIL DIAMETER $D$ inches	PENNYWEIGHT	$G = 0.43$	$G = 0.42$	$G = 0.37$	$G = 0.36$	$G = 0.35$
				HEM-FIR	SPRUCE-PINE-FIR	REDWOOD (open grain)	EASTERN SOFTWOODS SPRUCE-PINE-FIR(S) WESTERN CEDARS WESTERN WOODS	NORTHERN SPECIES
				Z	Z	Z	Z	Z
				lbs.	lbs.	lbs.	lbs.	lbs.
				× 25.4 for mm		× 4.45 for N		
1	2 1/2	0.113	8d	63	61	55	54	51
	3	0.128	10d	80	79	66	64	61
	3 1/4	0.128	12d	80	79	66	64	61
	3 1/2	0.135	16d	89	86	71	69	66
	4	0.148	20d	99	96	80	77	74
	4 1/2	0.148	30d	99	96	80	77	74
	5	0.162	40d	113	109	91	89	85
1 1/4	3	0.128	10d	80	79	70	69	67
	3 1/4	0.128	12d	80	79	70	69	67
	3 1/2	0.135	16d	89	88	78	76	74
	4	0.148	20d	102	100	89	87	84
	4 1/2	0.148	30d	102	100	89	87	84
	5	0.162	40d	122	120	103	100	95
1 1/2	3 1/4	0.128	12d	80	79	70	69	67
	3 1/2	0.135	16d	89	88	78	76	74
	4	0.148	20d	102	100	89	87	84
	4 1/2	0.148	30d	102	100	89	87	84
	5	0.162	40d	122	120	106	104	101

<sup>1</sup>Tabulated lateral design values (Z) for nailed connections shall be multiplied by all applicable adjustment factors (see Table 23-III-A).

<sup>2</sup>Tabulated lateral design values (Z) are for box nails inserted in side grain with nail axis perpendicular to wood fibers, and with the following nail bending yield strength ( $F_{yb}$ ):  
 $F_{yb} = 100,000$  psi (690 N/mm<sup>2</sup>) for 0.099-inch- (2.5 mm), 0.113-inch- (2.9 mm), 0.128-inch- (3.3 mm) and 0.135-inch-diameter (3.4 mm) box nails.  
 $F_{yb} = 90,000$  psi (621 N/mm<sup>2</sup>) for 0.148-inch- (3.8 mm) and 0.162-inch-diameter (4.1 mm) box nails.

**TABLE 23-III-II—COMMON WIRE NAIL DESIGN VALUES (Z) FOR SINGLE SHEAR<sup>1,2</sup>  
(Two-member) CONNECTIONS WITH BOTH MEMBERS OF IDENTICAL SPECIES**

SIDE MEMBER THICKNESS $t_s$ inches	NAIL LENGTH $L$ inches	NAIL DIAMETER $D$ inches	PENNYWEIGHT	$G = 0.67$	$G = 0.55$	$G = 0.50$	$G = 0.49$	$G = 0.46$					
				RED OAK	MIXED MAPLE SOUTHERN PINE	DOUGLAS FIR- LARCH	DOUGLAS FIR- LARCH (N)	DOUGLAS FIR (S) HEM-FIR (N)					
				Z	Z	Z	Z	Z					
				lbs.	lbs.	lbs.	lbs.	lbs.					
				× 25.4 for mm					× 4.45 for N				
1/2	2	0.113	6d	88	67	59	57	53					
	2 1/2	0.131	8d	110	85	76	73	69					
	3	0.148	10d	129	101	90	87	82					
	3 1/4	0.148	12d	129	101	90	87	82					
	3 1/2	0.162	16d	149	117	105	102	96					
	4	0.192	20d	172	137	124	121	114					
	4 1/2	0.207	30d	185	148	134	131	123					
	5	0.225	40d	200	162	147	143	135					
5/8	5 1/2	0.244	50d	205	166	151	147	139					
	6	0.263	60d	230	188	171	167	158					
	2	0.113	6d	94	76	66	64	59					
	2 1/2	0.131	8d	124	94	82	80	74					
	3	0.148	10d	144	110	97	94	87					
	3 1/4	0.148	12d	144	110	97	94	87					
	3 1/2	0.162	16d	165	126	112	109	101					
	4	0.192	20d	188	146	130	126	118					
5/8	4 1/2	0.207	30d	199	156	140	136	127					
	5	0.225	40d	213	169	151	147	138					
	5 1/2	0.244	50d	218	173	155	151	142					
	6	0.263	60d	242	194	175	170	160					

(Continued)

TABLE 23-III-II—COMMON WIRE NAIL DESIGN VALUES (Z) FOR SINGLE SHEAR<sup>1,2</sup>  
(Two-member) CONNECTIONS WITH BOTH MEMBERS OF IDENTICAL SPECIES—(Continued)

SIDE MEMBER THICKNESS $t_s$ inches	NAIL LENGTH $L$ inches	NAIL DIAMETER $D$ inches	PENNYWEIGHT	$G = 0.67$	$G = 0.55$	$G = 0.50$	$G = 0.49$	$G = 0.46$
				RED OAK	MIXED MAPLE SOUTHERN PINE	DOUGLAS FIR- LARCH	DOUGLAS FIR- LARCH (N)	DOUGLAS FIR (S) HEM-FIR (N)
$\times 25.4$ for mm				Z	Z	Z	Z	Z
				lbs.	lbs.	lbs.	lbs.	lbs.
				$\times 4.45$ for N				
3/4	2 1/2	0.131	8d	127	104	90	87	80
	3	0.148	10d	154	121	105	102	94
	3 1/4	0.148	12d	154	121	105	102	94
	3 1/2	0.162	16d	183	138	121	117	108
	4	0.192	20d	206	157	138	134	125
	4 1/2	0.207	30d	216	166	147	143	133
	5	0.225	40d	229	178	158	154	144
	5 1/2	0.244	50d	234	182	162	158	147
	6	0.263	60d	258	203	181	176	165
1	3	0.148	10d	154	128	118	115	109
	3 1/4	0.148	12d	154	128	118	115	109
	3 1/2	0.162	16d	184	154	141	137	125
	4	0.192	20d	222	183	159	154	142
	4 1/2	0.207	30d	243	192	167	162	149
	5	0.225	40d	268	202	177	171	159
	5 1/2	0.244	50d	274	207	181	175	162
	6	0.263	60d	298	227	199	193	179
1 1/4	3 1/4	0.148	12d	154	128	118	115	109
	3 1/2	0.162	16d	184	154	141	138	131
	4	0.192	20d	222	185	170	166	157
	4 1/2	0.207	30d	243	203	186	182	169
	5	0.225	40d	268	224	200	193	177
	5 1/2	0.244	50d	276	230	204	197	181
	6	0.263	60d	314	256	222	215	198

1 <sup>1/2</sup>	3 <sup>1/2</sup>	0.162	16d	184	154	141	138	131
	4	0.192	20d	222	185	170	166	157
	4 <sup>1/2</sup>	0.207	30d	243	203	186	182	172
	5	0.225	40d	268	224	205	201	190
	5 <sup>1/2</sup>	0.244	50d	276	230	211	206	196
	6	0.263	60d	314	262	240	235	220

<sup>1</sup>Tabulated lateral design values ( $Z$ ) for nailed connections shall be multiplied by all applicable adjustment factors (see Table 23-III-A).

<sup>2</sup>Tabulated lateral design values ( $Z$ ) are for common wire nails inserted in side grain with nail axis perpendicular to wood fibers, and with the following nail bending yield strength ( $F_{yb}$ ):

$F_{yb} = 100,000$  psi (690 N/mm<sup>2</sup>) for 0.113-inch- (2.9 mm) and 0.131-inch-diameter (3.3 mm) common wire nails.

$F_{yb} = 90,000$  psi (621 N/mm<sup>2</sup>) for 0.148-inch- (3.8 mm) and 0.162-inch-diameter (3.8 mm) common wire nails.

$F_{yb} = 80,000$  psi (552 N/mm<sup>2</sup>) for 0.192-inch- (4.9 mm), 0.207-inch- (5.3 mm) and 0.225-inch-diameter (5.7 mm) common wire nails.

$F_{yb} = 70,000$  psi (483 N/mm<sup>2</sup>) for 0.244-inch- (6.2 mm) and 0.263-inch-diameter (6.7 mm) common wire nails.

(Table continues)

TABLE 23-III-II—COMMON WIRE NAIL DESIGN VALUES (Z) FOR SINGLE SHEAR<sup>1,2</sup>  
(Two-member) CONNECTIONS WITH BOTH MEMBERS OF IDENTICAL SPECIES—(Continued)

SIDE MEMBER THICKNESS $t_s$ inches	NAIL LENGTH $L$ inches	NAIL DIAMETER $D$ inches	PENNYWEIGHT	G = 0.43 HEM-FIR	G = 0.42 SPRUCE-PINE-FIR	G = 0.37 REDWOOD (open grain)	G = 0.36 EASTERN SOFTWOODS SPRUCE-PINE-FIR(S) WESTERN CEDARS WESTERN WOODS	G = 0.35 NORTHERN SPECIES
				Z lbs.	Z lbs.	Z lbs.	Z lbs.	Z lbs.
	× 25.4 for mm			× 4.45 for N				
1/2	2	0.113	6d	49	47	41	40	38
	2 1/2	0.131	8d	63	61	53	52	50
	3	0.148	10d	75	73	64	63	61
	3 1/4	0.148	12d	75	73	64	63	61
	3 1/2	0.162	16d	89	87	76	74	72
	4	0.192	20d	105	103	91	89	86
	4 1/2	0.207	30d	115	112	99	97	94
	5	0.225	40d	126	123	108	104	98
5 1/2	0.244	50d	130	127	110	106	100	
6	0.263	60d	147	144	116	112	105	
5/8	2	0.113	6d	53	52	44	43	41
	2 1/2	0.131	8d	67	65	56	55	53
	3	0.148	10d	80	77	67	65	63
	3 1/4	0.148	12d	80	77	67	65	63
	3 1/2	0.162	16d	93	90	78	77	74
	4	0.192	20d	109	106	93	91	88
	4 1/2	0.207	30d	118	115	100	98	95
	5	0.225	40d	128	125	110	108	105
5 1/2	0.244	50d	132	129	113	111	107	
6	0.263	60d	149	145	128	126	122	

3/4	2 1/2	0.131	8d	73	70	60	58	56
	3	0.148	10d	85	83	70	69	66
	3 1/4	0.148	12d	85	83	70	69	66
	3 1/2	0.162	16d	99	96	82	80	77
	4	0.192	20d	114	111	96	93	90
	4 1/2	0.207	30d	122	119	103	101	97
	5	0.225	40d	132	129	112	110	106
	5 1/2	0.244	50d	136	132	115	113	109
1	6	0.263	60d	152	149	130	127	123
	3	0.148	10d	99	96	80	77	74
	3 1/4	0.148	12d	99	96	80	77	74
	3 1/2	0.162	16d	113	109	91	89	85
	4	0.192	20d	128	124	105	102	98
	4 1/2	0.207	30d	135	131	111	109	104
	5	0.225	40d	144	140	120	117	112
	5 1/2	0.244	50d	148	143	123	120	115
1 1/4	6	0.263	60d	164	159	137	134	129
	3 1/4	0.148	12d	102	100	89	87	84
	3 1/2	0.162	16d	122	120	103	100	95
	4	0.192	20d	145	140	116	113	108
	4 1/2	0.207	30d	152	147	123	119	114
	5	0.225	40d	160	155	130	127	121
	5 1/2	0.244	50d	163	158	133	129	124
	6	0.263	60d	179	174	147	143	137

(Continued)

**TABLE 23-III-II—COMMON WIRE NAIL DESIGN VALUES (Z) FOR SINGLE SHEAR<sup>1,2</sup>**  
**(Two-member) CONNECTIONS WITH BOTH MEMBERS OF IDENTICAL SPECIES—(Continued)**

SIDE MEMBER THICKNESS $t_s$ inches	NAIL LENGTH $L$ inches	NAIL DIAMETER $D$ inches		G = 0.43 HEM-FIR	G = 0.42 SPRUCE-PINE- FIR	G = 0.37 REDWOOD (open grain)	G = 0.36 EASTERN SOFTWOODS SPRUCE-PINE-FIR(S) WESTERN CEDARS WESTERN WOODS	G = 0.35 NORTHERN SPECIES
				Z lbs.	Z lbs.	Z lbs.	Z lbs.	Z lbs.
× 25.4 for mm			PENNYWEIGHT	× 4.45 for N				
1 1/2	3 1/2	0.162	10d	122	120	106	104	101
	4	0.192	20d	147	144	128	126	120
	4 1/2	0.207	30d	161	158	135	131	125
	5	0.225	40d	178	172	143	138	132
	5 1/2	0.244	50d	181	175	146	141	135
	6	0.263	60d	197	191	159	155	148

<sup>1</sup>Tabulated lateral design values (Z) for nailed connections shall be multiplied by all applicable adjustment factors (see Table 23-III-A).

<sup>2</sup>Tabulated lateral design values (Z) are for common wire nails inserted in side grain with nail axis perpendicular to wood fibers, and with the following nail bending yield strength ( $F_{yb}$ ):

$F_{yb} = 100,000$  psi (690 N/mm<sup>2</sup>) for 0.113-inch- (2.9 mm) and 0.131-inch-diameter (3.3 mm) common wire nails.

$F_{yb} = 90,000$  psi (621 N/mm<sup>2</sup>) for 0.148-inch- (3.8 mm) and 0.162-inch-diameter (4.1 mm) common wire nails.

$F_{yb} = 80,000$  psi (552 N/mm<sup>2</sup>) for 0.192-inch- (4.9 mm), 0.207-inch- (5.3 mm) and 0.225-inch-diameter (5.7 mm) common wire nails.

$F_{yb} = 70,000$  psi (483 N/mm<sup>2</sup>) for 0.244-inch- (6.2 mm) and 0.263-inch-diameter (6.7 mm) common wire nails.

**TABLE 23-III-JJ—THREADED HARDENED-STEEL NAIL DESIGN VALUES (Z) FOR SINGLE SHEAR<sup>1,2,3</sup>  
(Two-member) CONNECTIONS WITH BOTH MEMBERS OF IDENTICAL SPECIES**

SIDE MEMBER THICKNESS <i>t</i> inches	NAIL LENGTH <i>L</i> inches	WIRE DIAMETER <i>D</i> inches	PENNYWEIGHT	G = 0.67	G = 0.55	G = 0.50	G = 0.49	G = 0.46
				RED OAK Z lbs.	MIXED MAPLE SOUTHERN PINE Z lbs.	DOUGLAS FIR- LARCH Z lbs.	DOUGLAS FIR- LARCH (N) Z lbs.	DOUGLAS FIR (S) HEM-FIR (N) Z lbs.
× 25.4 for mm				× 4.45 for N				
1/2	2	0.120	6d	103	80	71	69	65
	2 1/2	0.120	8d	103	80	71	69	65
	3	0.135	10d	124	98	88	85	80
	3 1/4	0.135	12d	124	98	88	85	80
	3 1/2	0.148	16d	139	110	98	96	90
	4	0.177	20d	182	147	133	129	122
	4 1/2	0.177	30d	182	147	133	129	122
	5	0.177	40d	182	147	133	129	122
5/8	5 1/2	0.177	50d	182	147	133	129	122
	6	0.177	60d	182	147	133	129	122
	2 1/2	0.120	8d	116	88	77	75	70
	3	0.135	10d	137	106	93	91	84
	3 1/4	0.135	12d	137	106	93	91	84
	3 1/2	0.148	16d	153	118	104	101	95
	4	0.177	20d	196	154	138	134	126
	4 1/2	0.177	30d	196	154	138	134	126
5	0.177	40d	196	154	138	134	126	
5 1/2	0.177	50d	196	154	138	134	126	
6	0.177	60d	196	154	138	134	126	

(Continued)

TABLE 23-III-JJ—THREADED HARDENED-STEEL NAIL DESIGN VALUES (Z) FOR SINGLE SHEAR<sup>1,2,3</sup>  
(Two-member) CONNECTIONS WITH BOTH MEMBERS OF IDENTICAL SPECIES—(Continued)

SIDE MEMBER THICKNESS $t_s$ inches	NAIL LENGTH $L$ inches	WIRE DIAMETER $D$ inches		G = 0.67	G = 0.55	G = 0.50	G = 0.49	G = 0.46
				RED OAK	MIXED MAPLE SOUTHERN PINE	DOUGLAS FIR- LARCH	DOUGLAS FIR- LARCH (N)	DOUGLAS FIR (S) HEM-FIR (N)
× 25.4 for mm			PENNYWEIGHT	Z lbs.	Z lbs.	Z lbs.	Z lbs.	Z lbs.
				× 4.45 for N				
3/4	2 1/2	0.120	8d	121	97	84	82	75
	3	0.135	10d	152	115	101	97	90
	3 1/4	0.135	12d	152	115	101	97	90
	3 1/2	0.148	16d	169	128	112	109	101
	4	0.177	20d	212	164	145	141	131
	4 1/2	0.177	30d	212	164	145	141	131
	5	0.177	40d	212	164	145	141	131
	5 1/2	0.177	50d	212	164	145	141	131
	6	0.177	60d	212	164	145	141	131
	7	0.207	70d	229	178	159	155	145
8	0.207	80d	229	178	159	155	145	
9	0.207	90d	229	178	159	155	145	
1	2 1/2	0.120	8d	121	102	93	91	86
	3	0.135	10d	154	128	118	114	104
	3 1/4	0.135	12d	154	128	118	114	104
	3 1/2	0.148	16d	174	145	131	126	116
	4	0.177	20d	241	188	164	159	146
	4 1/2	0.177	30d	241	188	164	159	146
	5	0.177	40d	241	188	164	159	146
	5 1/2	0.177	50d	241	188	164	159	146
	6	0.177	60d	241	188	164	159	146
	7	0.207	70d	268	202	177	171	159
8	0.207	80d	268	202	177	171	159	
9	0.207	90d	268	202	177	171	159	

1 <sup>1/4</sup>	3	0.135	10d	154	128	118	115	109
	3 <sup>1/4</sup>	0.135	12d	154	128	118	115	109
	3 <sup>1/2</sup>	0.148	16d	174	145	133	130	123
	4	0.177	20d	241	201	184	180	165
	4 <sup>1/2</sup>	0.177	30d	241	201	184	180	165
	5	0.177	40d	241	201	184	180	165
	5 <sup>1/2</sup>	0.177	50d	241	201	184	180	165
	6	0.177	60d	241	201	184	180	165
	7	0.207	70d	271	227	199	192	177
1 <sup>1/2</sup>	8	0.207	80d	271	227	199	192	177
	9	0.207	90d	271	227	199	192	177
	3 <sup>1/4</sup>	0.135	12d	154	128	118	115	109
	3 <sup>1/2</sup>	0.148	16d	174	145	133	130	123
	4	0.177	20d	241	201	184	180	171
	4 <sup>1/2</sup>	0.177	30d	241	201	184	180	171
	5	0.177	40d	241	201	184	180	171
	5 <sup>1/2</sup>	0.177	50d	241	201	184	180	171
	6	0.177	60d	241	201	184	180	171
7	0.207	70d	271	227	208	203	193	
8	0.207	80d	271	227	208	203	193	
9	0.207	90d	271	227	208	203	193	

<sup>1</sup>Tabulated lateral design values (Z) for nailed connections shall be multiplied by all applicable adjustment factors (see Table 23-III-A).

<sup>2</sup>Tabulated lateral design values (Z) are for threaded hardened-steel nails inserted in side grain with nail axis perpendicular to wood fibers, and with the following nail bending yield strength ( $F_{yb}$ ):

$F_{yb}$  = 130,000 psi (897 N/mm<sup>2</sup>) for 0.120-inch- (3.0 mm) and 0.135-inch-diameter (3.4 mm) threaded hardened-steel nails.

$F_{yb}$  = 115,000 psi (793 N/mm<sup>2</sup>) for 0.148-inch- (3.8 mm) and 0.177-inch-diameter (4.5 mm) threaded hardened-steel nails.

$F_{yb}$  = 100,000 psi (690 N/mm<sup>2</sup>) for 0.207-inch-diameter (5.3 mm) threaded hardened-steel nails.

<sup>3</sup>Tabulated lateral design values (Z) shall not apply for annularly threaded nails when threads occur at the shear plane (see Section 2340.3.1).

(Table continues)

TABLE 23-III-JJ—THREADED HARDENED-STEEL NAIL DESIGN VALUES (Z) FOR SINGLE SHEAR<sup>1,2,3</sup>  
(Two-member) CONNECTIONS WITH BOTH MEMBERS OF IDENTICAL SPECIES—(Continued)

SIDE MEMBER THICKNESS $\frac{1}{2}$ inches	NAIL LENGTH L inches	WIRE DIAMETER D inches	PENNY-WEIGHT	G = 0.63	G = 0.42	G = 0.37	G = 0.36	G = 0.35
				HEM-FIR	SPRUCE-PINE-FIR	REDWOOD (open grain)	EASTERN SOFTWOODS SPRUCE-PINE-FIR (S) WESTERN CEDARS WESTERN WOODS	NORTHERN SPECIES
× 25.4 for mm				Z lbs.	Z lbs.	Z lbs.	Z lbs.	Z lbs.
				× 4.45 for N				
$\frac{1}{2}$	2	0.120	6d	60	58	51	50	48
	2½	0.120	8d	60	58	51	50	48
	3	0.135	10d	74	72	63	62	60
	¾	0.135	12d	74	72	63	62	60
	¾	0.148	16d	83	81	72	70	68
	4	0.177	20d	114	111	98	96	94
	4½	0.177	30d	114	111	98	96	94
	5	0.177	40d	114	111	98	96	94
$\frac{5}{8}$	5½	0.177	50d	114	111	98	96	94
	6	0.177	60d	114	111	98	96	94
	2½	0.120	8d	63	62	53	52	50
	3	0.135	10d	78	75	65	64	62
	¾	0.135	12d	78	75	65	64	62
	¾	0.148	16d	87	85	73	72	69
	4	0.177	20d	116	113	99	97	94
	4½	0.177	30d	116	113	99	97	94
$\frac{5}{8}$	5	0.177	40d	116	113	99	97	94
	5½	0.177	50d	116	113	99	97	94
	6	0.177	60d	116	113	99	97	94
	6	0.177	60d	116	113	99	97	94

3/4	2 1/2	0.120	8d	68	66	56	55	52
	3	0.135	10d	82	80	68	67	64
	3 1/4	0.135	12d	82	80	68	67	64
	3 1/2	0.148	16d	92	89	77	75	72
	4	0.177	20d	121	117	102	100	96
	4 1/2	0.177	30d	121	117	102	100	96
	5	0.177	40d	121	117	102	100	96
	5 1/2	0.177	50d	121	117	102	100	96
	6	0.177	60d	121	117	102	100	96
1	7	0.207	70d	133	130	113	111	107
	8	0.207	80d	133	130	113	111	107
	9	0.207	90d	133	130	113	111	107
	2 1/2	0.120	8d	80	77	64	62	59
	3	0.135	10d	94	91	76	74	71
	3 1/4	0.135	12d	94	91	76	74	71
	3 1/2	0.148	16d	105	101	85	83	79
	4	0.177	20d	133	129	110	107	103
	4 1/2	0.177	30d	133	129	110	107	103
1 1/4	5	0.177	40d	133	129	110	107	103
	5 1/2	0.177	50d	133	129	110	107	103
	6	0.177	60d	133	129	110	107	103
	7	0.207	70d	145	140	120	117	113
	8	0.207	80d	145	140	120	117	113
	9	0.207	90d	145	140	120	117	113
	3	0.135	10d	102	100	86	83	79
	3 1/4	0.135	12d	102	100	86	83	79
	3 1/2	0.148	16d	115	113	95	93	88
1 1/4	4	0.177	20d	149	144	120	117	112
	4 1/2	0.177	30d	149	144	120	117	112

(Continued)

**TABLE 23-III-JJ—THREADED HARDENED-STEEL NAIL DESIGN VALUES (Z) FOR SINGLE SHEAR<sup>1,2,3</sup>  
(Two-member) CONNECTIONS WITH BOTH MEMBERS OF IDENTICAL SPECIES—(Continued)**

SIDE MEMBER THICKNESS $t_s$ inches	NAIL LENGTH $L$ inches	WIRE DIAMETER $D$ inches	PENNY-WEIGHT	$G = 0.63$	$G = 0.42$	$G = 0.37$	$G = 0.36$	$G = 0.35$
				HEM-FIR	SPRUCE-PINE-FIR	REDWOOD (open grain)	EASTERN SOFTWOODS SPRUCE-PINE-FIR (S) WESTERN CEDARS WESTERN WOODS	NORTHERN SPECIES
× 25.4 for mm				Z lbs.	Z lbs.	Z lbs.	Z lbs.	Z lbs.
				× 4.45 for N				
1 <sup>1/4</sup>	5	0.177	40d	149	144	120	117	112
	5 <sup>1/2</sup>	0.177	50d	149	144	120	117	112
	6	0.177	60d	149	144	120	117	112
	7	0.207	70d	160	155	130	127	121
	8	0.207	80d	160	155	130	127	121
	9	0.207	90d	160	155	130	127	121
1 <sup>1/2</sup>	3 <sup>1/4</sup>	0.135	12d	102	100	89	87	84
	3 <sup>1/2</sup>	0.148	16d	115	113	100	98	95
	4	0.177	20d	160	156	132	129	123
	4 <sup>1/2</sup>	0.177	30d	160	156	132	129	123
	5	0.177	40d	160	156	132	129	123
	5 <sup>1/2</sup>	0.177	50d	160	156	132	129	123
	6	0.177	60d	160	156	132	129	123
	7	0.207	70d	177	171	142	138	132
	8	0.207	80d	177	171	142	138	132
9	0.207	90d	177	171	142	138	132	

<sup>1</sup>Tabulated lateral design values (Z) for nailed connections shall be multiplied by all applicable adjustment factors (see Table 23-III-A).

<sup>2</sup>Tabulated lateral design values (Z) are for threaded hardened-steel nails inserted in side grain with nail axis perpendicular to wood fibers, and with the following nail bending yield strength ( $F_{yb}$ ):

$F_{yb} = 130,000$  psi (897 N/mm<sup>2</sup>) for 0.120-inch- (3.0 mm) and 0.135-inch-diameter (3.4 mm) threaded hardened-steel nails.

$F_{yb} = 115,000$  psi (793 N/mm<sup>2</sup>) for 0.148-inch- (3.8 mm) and 0.177-inch-diameter (4.5 mm) threaded hardened-steel nails.

$F_{yb} = 100,000$  psi (690 N/mm<sup>2</sup>) for 0.207-inch-diameter (5.3 mm) threaded hardened-steel nails.

<sup>3</sup>Tabulated lateral design values (Z) shall not apply for annularly threaded nails when threads occur at the shear plane (see Section 2340.3.1).

**TABLE 23-III-KK—COMMON WIRE SPIKE DESIGN VALUES (Z) FOR SINGLE SHEAR (Two-member)<sup>1,2</sup>  
CONNECTIONS WITH BOTH MEMBERS OF IDENTICAL SPECIES**

SIDE MEMBER THICKNESS $t_s$ inches	SPIKE LENGTH $L$ inches	SPIKE DIAMETER $D$ inches	PENNY-WEIGHT	G = 0.67	G = 0.55	G = 0.50	G = 0.49	G = 0.46
				RED OAK	MIXED MAPLE SOUTHERN PINE	DOUGLAS FIR-LARCH	DOUGLAS FIR-LARCH (N)	DOUGLAS FIR (S) HEM-FIR (N)
$\times 25.4$ for mm				Z	Z	Z	Z	Z
				lbs.	lbs.	lbs.	lbs.	lbs.
				$\times 4.45$ for N				
1/2	3	0.192	10d	172	137	124	121	114
	3 1/4	0.192	12d	172	137	124	121	114
	3 1/2	0.207	16d	185	148	134	131	123
	4	0.225	20d	200	162	147	143	135
	4 1/2	0.244	30d	205	166	151	147	139
	5	0.263	40d	230	188	171	167	158
	5 1/2	0.283	50d	247	201	183	179	169
	6	0.283	60d	247	201	183	179	169
5/8	3	0.192	10d	188	146	130	126	118
	3 1/4	0.192	12d	188	146	130	126	118
	3 1/2	0.207	16d	199	156	140	136	127
	4	0.225	20d	213	169	151	147	138
	4 1/2	0.244	30d	218	173	155	151	142
	5	0.263	40d	242	194	175	170	160
	5 1/2	0.283	50d	260	208	187	183	172
	6	0.283	60d	260	208	187	183	172
3/4	3 1/4	0.192	12d	206	157	138	134	125
	3 1/2	0.207	16d	216	166	147	143	133
	4	0.225	20d	229	178	158	154	144
	4 1/2	0.244	30d	234	182	162	158	147
	5	0.263	40d	258	203	181	176	165
	5 1/2	0.283	50d	277	217	194	189	177
	6	0.283	60d	277	217	194	189	177
	7	0.312	5 1/16	325	257	231	225	211
	8 1/2	0.375	3 3/8	401	319	287	279	263

(Continued)

1994 UNIFORM BUILDING CODE

23-III-KK

2-1071

**TABLE 23-III-KK—COMMON WIRE SPIKE DESIGN VALUES (Z) FOR SINGLE SHEAR (Two-member)<sup>1,2</sup>  
CONNECTIONS WITH BOTH MEMBERS OF IDENTICAL SPECIES—(Continued)**

SIDE MEMBER THICKNESS $t_s$ inches	SPIKE LENGTH $L$ inches	SPIKE DIAMETER $D$ inches	PENNY-WEIGHT	G = 0.67	G = 0.55	G = 0.50	G = 0.49	G = 0.46
				RED OAK	MIXED MAPLE SOUTHERN PINE	DOUGLAS FIR-LARCH	DOUGLAS FIR-LARCH (N)	DOUGLAS FIR (S) HEM-FIR (N)
× 25.4 for mm				Z lbs.	Z lbs.	Z lbs.	Z lbs.	Z lbs.
				× 4.45 for N				
1	3 1/2	0.207	16d	243	192	167	162	149
	4	0.225	20d	268	202	177	171	159
	4 1/2	0.244	30d	274	207	181	175	162
	5	0.263	40d	298	227	199	193	179
	5 1/2	0.283	50d	321	243	214	207	192
	6	0.283	60d	321	243	214	207	192
	7	0.312	5/16	369	283	250	243	226
	8 1/2	0.375	3/8	452	348	309	300	279
1 1/4	4	0.225	20d	268	224	200	193	177
	4 1/2	0.244	30d	276	230	204	197	181
	5	0.263	40d	314	256	222	215	198
	5 1/2	0.283	50d	337	275	239	231	213
	6	0.283	60d	337	275	239	231	213
	7	0.312	5/16	409	316	276	267	247
	8 1/2	0.375	3/8	512	386	338	327	303
1 1/2	4 1/2	0.244	30d	276	230	211	206	196
	5	0.263	40d	314	262	240	235	220
	5 1/2	0.283	50d	337	281	257	252	236
	6	0.283	60d	337	281	257	252	236
	7	0.312	5/16	409	342	305	295	271
	8 1/2	0.375	3/8	512	428	373	360	331
2 1/2	6	0.283	60d	337	281	257	252	239
	7	0.312	5/16	409	342	313	306	290
	8 1/2	0.375	3/8	512	428	391	383	363
3 1/2	8 1/2	0.375	3/8	512	428	391	383	363

<sup>1</sup>Tabulated lateral design values (Z) for spike connections shall be multiplied by all applicable adjustment factors (see Table 23-III-A).

<sup>2</sup>Tabulated lateral design values (Z) are for common wire spikes inserted in side grain with spike axis perpendicular to wood fibers, and with the following spike bending yield strength ( $F_{yb}$ ):

$F_{yb} = 80,000$  psi (552 N/mm<sup>2</sup>) for 0.192-inch- (4.9 mm), 0.207-inch- (5.3 mm) and 0.225-inch-diameter (5.7 mm) common wire spikes.  
 $F_{yb} = 70,000$  psi (483 N/mm<sup>2</sup>) for 0.224-inch- (5.7 mm) and 0.263-inch-diameter (6.7 mm) common wire spikes.  
 $F_{yb} = 60,000$  psi (414 N/mm<sup>2</sup>) for 0.283-inch- (7.2 mm) and  $\frac{3}{16}$ -inch-diameter (7.9 mm) common wire spikes.  
 $F_{yb} = 45,000$  psi (310 N/mm<sup>2</sup>) for  $\frac{3}{8}$ -inch-diameter (9.5 mm) common wire spikes.

(Table continues)

SIDE MEMBER THICKNESS $t_s$ inches	SPIKE LENGTH $L$ inches	SPIKE DIAMETER $D$ inches	PENNY-WEIGHT	G = 0.43	G = 0.42	G = 0.37	G = 0.36	G = 0.35
				HEM-FIR	SPRUCE-PINE-FIR	REDWOOD (open grain)	EASTERN SOFTWOODS SPRUCE-PINE-FIR (S) WESTERN CEDARS WESTERN WOODS	NORTHERN SPECIES
				Z lbs.	Z lbs.	Z lbs.	Z lbs.	Z lbs.
× 25.4 for mm				× 4.45 for N				
1/2	3	0.192	10d	105	103	91	89	86
	3 1/4	0.192	12d	105	103	91	89	86
	3 1/2	0.207	16d	115	112	99	97	94
	4	0.225	20d	126	123	108	104	98
	4 1/2	0.244	30d	130	127	110	106	100
	5	0.263	40d	147	144	116	112	105
	5 1/2	0.283	50d	158	155	125	120	113
	6	0.283	60d	158	155	125	120	113
5/8	3	0.192	10d	109	106	93	91	88
	3 1/4	0.192	12d	109	106	93	91	88
	3 1/2	0.207	16d	118	115	100	98	95
	4	0.225	20d	128	125	110	108	105
	4 1/2	0.244	30d	132	129	113	111	107
	5	0.263	40d	149	145	128	126	122
	5 1/2	0.283	50d	160	156	138	135	131
	6	0.283	60d	160	156	138	135	131

(Continued)

TABLE 23-III-KK—COMMON WIRE SPIKE DESIGN VALUES (Z) FOR SINGLE SHEAR (Two-member)<sup>1,2</sup>  
 CONNECTIONS WITH BOTH MEMBERS OF IDENTICAL SPECIES—(Continued)

SIDE MEMBER THICKNESS $\frac{t}{8}$ inches	SPIKE LENGTH $L$ inches	SPIKE DIAMETER $D$ inches	PENNY-WEIGHT	G = 0.43	G = 0.42	G = 0.37	G = 0.36	G = 0.35	
				HEM-FIR	SPRUCE-PINE-FIR	REDWOOD (open grain)	EASTERN SOFTWOODS SPRUCE-PINE-FIR (S) WESTERN CEDARS WESTERN WOODS	NORTHERN SPECIES	
				Z lbs.	Z lbs.	Z lbs.	Z lbs.	Z lbs.	
× 25.4 for mm				× 4.45 for N					
3/4	3 1/4	0.192	12d	114	111	96	93	90	
	3 1/2	0.207	16d	122	119	103	101	97	
	4	0.225	20d	132	129	112	110	106	
	4 1/2	0.244	30d	136	132	115	113	109	
	5	0.263	40d	152	149	130	127	123	
	5 1/2	0.283	50d	163	159	140	137	132	
	6	0.283	60d	163	159	140	137	132	
	7	0.312	5/16	196	191	168	165	160	
	8 1/2	0.375	3/8	244	238	210	206	199	
1	3 1/2	0.207	16d	135	131	111	109	104	
	4	0.225	20d	144	140	120	117	112	
	4 1/2	0.244	30d	148	143	123	120	115	
	5	0.263	40d	164	159	137	134	129	
	5 1/2	0.283	50d	176	171	147	143	138	
	6	0.283	60d	176	171	147	143	138	
	7	0.312	5/16	207	202	175	171	165	
		8 1/2	0.375	3/8	257	250	217	212	205
1 1/4	4	0.225	20d	160	155	130	127	121	
	4 1/2	0.244	30d	163	158	133	129	124	
	5	0.263	40d	179	174	147	143	137	
	5 1/2	0.283	50d	193	186	158	154	147	
	6	0.283	60d	193	186	158	154	147	
	7	0.312	5/16	224	217	185	180	173	
		8 1/2	0.375	3/8	276	268	229	223	214

1 1/2	4 1/2	0.244	30d	181	175	146	141	135
	5	0.263	40d	197	191	159	155	148
	5 1/2	0.283	50d	212	205	171	166	159
	6	0.283	60d	212	205	171	166	159
	7	0.312	5/16	244	236	199	193	185
	8 1/2	0.375	3/8	299	290	244	238	228
2 1/2	6	0.283	60d	223	219	194	191	185
	7	0.312	5/16	271	266	236	232	225
	8 1/2	0.375	3/8	340	332	296	290	281
3 1/2	8 1/2	0.375	3/8	340	332	296	290	281

<sup>1</sup>Tabulated lateral design values (Z) for spike connections shall be multiplied by all applicable adjustment factors (see Table 23-III-A).

<sup>2</sup>Tabulated lateral design values (Z) are for common wire spikes inserted in side grain with spike axis perpendicular to wood fibers, and with the following spike bending yield strength ( $F_{yb}$ ):

$F_{yb} = 80,000$  psi (552 N/mm<sup>2</sup>) for 0.192-inch- (4.9 mm), 0.207-inch- (5.3 mm) and 0.225-inch-diameter (5.7 mm) common wire spikes.

$F_{yb} = 70,000$  psi (483 N/mm<sup>2</sup>) for 0.224-inch- (5.7 mm) and 0.263-inch-diameter (6.7 mm) common wire spikes.

$F_{yb} = 60,000$  psi (414 N/mm<sup>2</sup>) for 0.283-inch- (7.2 mm) and 5/16-inch-diameter (7.9 mm) common wire spikes.

$F_{yb} = 45,000$  psi (310 N/mm<sup>2</sup>) for 3/8-inch-diameter (9.5 mm) common wire spikes.

TABLE 23-III-LL—BOX NAIL DESIGN VALUES (Z) FOR SINGLE SHEAR (Two-member) CONNECTIONS<sup>1,2,3</sup>  
WITH ASTM A 446, GRADE A STEEL SIDE PLATE

STEEL SIDE PLATE	NAIL LENGTH L inches	NAIL DIAMETER D inches	PENNY- WEIGHT	G = 0.67	G = 0.55	G = 0.50	G = 0.49	G = 0.46
				RED OAK	MIXED MAPLE SOUTHERN PINE	DOUGLAS FIR- LARCH	DOUGLAS FIR-LARCH (N)	DOUGLAS FIR (S) HEM-FIR (N)
				Z	Z	Z	Z	Z
				lbs.	lbs.	lbs.	lbs.	lbs.
× 25.4 for mm				× 4.45 for N				
10 gage $t_s=0.134''$	2	0.099	6d	84	74	69	67	65
	2 1/2	0.113	8d	104	90	84	83	79
	3	0.128	10d	127	111	103	101	97
	3 1/4	0.128	12d	127	111	103	101	97
	3 1/2	0.135	16d	139	121	113	111	106
	4	0.148	20d	157	137	127	125	119
	4 1/2	0.148	30d	157	137	127	125	119
	5	0.162	40d	184	160	149	146	140
11 gage $t_s=0.12''$	2	0.099	6d	80	70	65	64	61
	2 1/2	0.113	8d	100	87	81	79	76
	3	0.128	10d	123	107	100	98	94
	3 1/4	0.128	12d	123	107	100	98	94
	3 1/2	0.135	16d	135	118	109	107	103
	4	0.148	20d	153	133	123	121	116
	4 1/2	0.148	30d	153	133	123	121	116
	5	0.162	40d	180	156	145	142	136
12 gage $t_s=0.105''$	2	0.099	6d	77	67	62	61	58
	2 1/2	0.113	8d	96	83	78	76	73
	3	0.128	10d	120	104	96	95	90
	3 1/4	0.128	12d	120	104	96	95	90
	3 1/2	0.135	16d	132	114	106	104	99
	4	0.148	20d	149	129	120	118	112
	4 1/2	0.148	30d	149	129	120	118	112
	5	0.162	40d	176	152	141	139	133

14 gage $t_s=0.075''$	2	0.099	6d	70	61	57	56	53
	2 1/2	0.113	8d	90	78	72	71	68
	3	0.128	10d	114	98	91	89	85
	3 1/4	0.128	12d	114	98	91	89	85
	3 1/2	0.135	16d	126	109	101	99	94
	4	0.148	20d	144	124	115	112	107
	4 1/2	0.148	30d	144	124	115	112	107
	5	0.162	40d	171	147	136	134	128
16 gage $t_s=0.06''$	2	0.099	6d	68	59	55	54	51
	2 1/2	0.113	8d	88	76	70	69	66
	3	0.128	10d	112	97	89	88	84
	3 1/4	0.128	12d	112	97	89	88	84
	3 1/2	0.135	16d	125	107	99	97	93
	4	0.148	20d	142	122	113	111	106
	4 1/2	0.148	30d	142	122	113	111	106
	5	0.162	40d	170	146	135	132	126
18 gage $t_s=0.048''$	2	0.099	6d	67	58	54	53	50
	2 1/2	0.113	8d	87	75	69	68	65
	3	0.128	10d	112	96	89	87	83
	3 1/4	0.128	12d	112	96	89	87	83
	3 1/2	0.135	16d	124	106	98	97	92
	4	0.148	20d	142	121	112	110	105
	4 1/2	0.148	30d	142	121	112	110	105
	5	0.162	40d	170	145	134	132	125
20 gage $t_s=0.036''$	2	0.099	6d	67	57	53	52	50
	2 1/2	0.113	8d	87	75	69	68	64
	3	0.128	10d	112	96	88	87	82
	3 1/4	0.128	12d	112	96	88	87	82
	3 1/2	0.135	16d	125	106	98	96	92

<sup>1</sup>Tabulated lateral design values (Z) for nailed connections shall be multiplied by all applicable adjustment factors (see Table 23-III-A).

<sup>2</sup>Tabulated lateral design values (Z) are for box nails inserted in side grain with nail axis perpendicular to wood fibers, and with the following nail bending yield strength

( $F_{yb}$ ):

$F_{yb} = 100,000$  psi (690 N/mm<sup>2</sup>) for 0.099-inch- (2.5 mm), 0.113-inch- (2.9 mm), 0.128-inch- (3.3 mm) and 0.135-inch-diameter (3.4 mm) box nails.

$F_{yb} = 90,000$  psi (621 N/mm<sup>2</sup>) for 0.148-inch- (3.8 mm) and 0.162-inch-diameter (4.1 mm) box nails.

<sup>3</sup>Tabulated lateral design values (Z) are based on a dowel-bearing strength ( $F_e$ ) of 45,000 psi (310 N/mm<sup>2</sup>) for ASTM A 446, Grade A steel.

(Table continues)

TABLE 23-III-LL—BOX NAIL DESIGN VALUES (Z) FOR SINGLE SHEAR (Two-member) CONNECTIONS<sup>1,2,3</sup>  
WITH ASTM A 446, GRADE A STEEL SIDE PLATE—(Continued)

STEEL SIDE PLATE	NAIL LENGTH L inches	NAIL DIAMETER D inches	PENNY- WEIGHT	G = 0.43	G = 0.42	G = 0.37	G = 0.36	G = 0.35
				HEM-FIR	SPRUCE-PINE-FIR	REDWOOD (open grain)	EASTERN SOFTWOODS SPRUCE-PINE-FIR (S) WESTERN CEDARS WESTERN WOODS	NORTHERN SPECIES
				Z	Z	Z	Z	Z
				lbs.	lbs.	lbs.	lbs.	lbs.
× 25.4 for mm				× 4.45 for N				
10 gage $t_s=0.134''$	2	0.099	6d	61	60	54	54	52
	2 1/2	0.113	8d	75	74	67	66	64
	3	0.128	10d	92	90	82	80	78
	3 1/4	0.128	12d	92	90	82	80	78
	3 1/2	0.135	16d	100	98	89	88	85
	4	0.148	20d	113	111	100	99	96
	4 1/2	0.148	30d	113	111	100	99	96
5	0.162	40d	132	129	117	115	112	
11 gage $t_s=0.12''$	2	0.099	6d	58	57	52	51	50
	2 1/2	0.113	8d	72	71	64	63	61
	3	0.128	10d	89	87	79	77	75
	3 1/4	0.128	12d	89	87	79	77	75
	3 1/2	0.135	16d	97	95	86	85	82
	4	0.148	20d	109	107	97	95	93
	4 1/2	0.148	30d	109	107	97	95	93
5	0.162	40d	128	126	114	112	109	
12 gage $t_s=0.105''$	2	0.099	6d	55	54	49	48	47
	2 1/2	0.113	8d	69	68	61	60	58
	3	0.128	10d	85	84	76	74	72
	3 1/4	0.128	12d	85	84	76	74	72
	3 1/2	0.135	16d	94	92	83	82	80
	4	0.148	20d	106	104	94	92	90
	4 1/2	0.148	30d	106	104	94	92	90
5	0.162	40d	125	123	111	109	106	

14 gage $t_s=0.075''$	2	0.099	6d	50	49	44	44	43
	2 1/2	0.113	8d	64	63	56	56	54
	3	0.128	10d	81	79	71	70	68
	3 1/4	0.128	12d	81	79	71	70	68
	3 1/2	0.135	16d	89	87	79	77	75
	4	0.148	20d	101	99	89	88	85
	4 1/2	0.148	30d	101	99	89	88	85
5	0.162	40d	120	118	106	104	101	
16 gage $t_s=0.06''$	2	0.099	6d	48	47	43	42	41
	2 1/2	0.113	8d	62	61	55	54	52
	3	0.128	10d	79	77	70	68	66
	3 1/4	0.128	12d	79	77	70	68	66
	3 1/2	0.135	16d	87	86	77	76	74
	4	0.148	20d	100	98	88	86	84
	4 1/2	0.148	30d	100	98	88	86	84
5	0.162	40d	119	116	105	103	100	
18 gage $t_s=0.048''$	2	0.099	6d	47	46	42	41	40
	2 1/2	0.113	8d	61	60	54	53	51
	3	0.128	10d	78	76	69	67	66
	3 1/4	0.128	12d	78	76	69	67	66
	3 1/2	0.135	16d	87	85	76	75	73
	4	0.148	20d	99	97	87	85	83
	4 1/2	0.148	30d	99	97	87	85	83
5	0.162	40d	118	116	104	102	99	
20 gage $t_s=0.036''$	2	0.099	6d	47	46	41	40	39
	2 1/2	0.113	8d	61	59	53	52	51
	3	0.128	10d	78	76	68	67	65
	3 1/4	0.128	12d	78	76	68	67	65
	3 1/2	0.135	16d	86	84	76	74	72

<sup>1</sup>Tabulated lateral design values (Z) for nailed connections shall be multiplied by all applicable adjustment factors (see Table 23-III-A).

<sup>2</sup>Tabulated lateral design values (Z) are for box nails inserted in side grain with nail axis perpendicular to wood fibers, and with the following nail bending yield strength

( $F_{yb}$ ):

$F_{yb} = 100,000$  psi (690 N/mm<sup>2</sup>) for 0.099-inch- (2.5 mm), 0.113-inch- (2.9 mm), 0.128-inch- (3.3 mm) and 0.135-inch-diameter (3.4 mm) box nails.

$F_{yb} = 90,000$  psi (621 N/mm<sup>2</sup>) for 0.148-inch- (3.8 mm) and 0.162-inch-diameter (4.1 mm) box nails.

<sup>3</sup>Tabulated lateral design values (Z) are based on a dowel-bearing strength ( $F_e$ ) of 45,000 psi (310 N/mm<sup>2</sup>) for ASTM A 446, Grade A steel.

TABLE 23-III-MM—COMMON WIRE NAIL DESIGN VALUES (Z) FOR SINGLE SHEAR<sup>1,2,3</sup>  
(Two-member) CONNECTIONS WITH ASTM A 446, GRADE A STEEL SIDE PLATE

STEEL SIDE PLATE	NAIL LENGTH L inches	NAIL DIAMETER D inches	PENNY- WEIGHT	G = 0.67	G = 0.55	G = 0.50	G = 0.49	G = 0.46
				RED OAK	MIXED MAPLE SOUTHERN PINE	DOUGLAS FIR- LARCH	DOUGLAS FIR-LARCH (N)	DOUGLAS FIR (S) HEM-FIR (N)
				Z lbs.	Z lbs.	Z lbs.	Z lbs.	Z lbs.
× 25.4 for mm				× 4.45 for N				
3 gage $t_s=0.239''$	5 1/2	0.244	50d	301	263	245	241	230
	6	0.263	60d	334	291	271	266	255
7 gage $t_s=0.179''$	4	0.192	20d	233	203	189	185	177
	4 1/2	0.207	30d	249	217	202	198	189
	5	0.225	40d	269	234	217	213	204
	5 1/2	0.244	50d	276	240	223	219	209
10 gage $t_s=0.134''$	6	0.263	60d	309	268	249	245	234
	2	0.113	6d	104	90	84	83	79
	2 1/2	0.131	8d	133	115	107	105	101
	3	0.148	10d	157	137	127	125	119
	3 1/4	0.148	12d	157	137	127	125	119
	3 1/2	0.162	16d	184	160	149	146	140
	4	0.192	20d	217	188	174	171	164
	4 1/2	0.207	30d	234	203	188	185	176
11 gage $t_s=0.12''$	5	0.225	40d	256	221	205	201	192
	5 1/2	0.244	50d	262	227	210	206	197
	6	0.263	60d	296	256	237	233	222
	2	0.113	6d	100	87	81	79	76
	2 1/2	0.131	8d	128	112	104	102	97
	3	0.148	10d	153	133	123	121	116
	3 1/4	0.148	12d	153	133	123	121	116
	3 1/2	0.162	16d	180	156	145	142	136
11 gage $t_s=0.12''$	4	0.192	20d	213	184	171	168	160
	4 1/2	0.207	30d	231	199	185	181	173
	5	0.225	40d	252	218	202	198	189
	5 1/2	0.244	50d	259	224	207	204	194
	6	0.263	60d	294	253	234	230	220

12 gage $t_s=0.105''$	2	0.113	6d	96	83	78	76	73
	2 <sup>1/2</sup>	0.131	8d	125	108	100	99	94
	3	0.148	10d	149	129	120	118	112
	3 <sup>1/4</sup>	0.148	12d	149	129	120	118	112
	3 <sup>1/2</sup>	0.162	16d	176	152	141	139	133
	4	0.192	20d	209	181	168	164	157
	4 <sup>1/2</sup>	0.207	30d	228	196	182	178	170
	5	0.225	40d	250	215	199	196	187
5 <sup>1/2</sup>	0.244	50d	257	221	205	201	192	
6	0.263	60d	291	251	232	228	217	
14 gage $t_s=0.075''$	2	0.113	6d	90	78	72	71	68
	2 <sup>1/2</sup>	0.131	8d	119	103	95	93	89
	3	0.148	10d	144	124	115	112	107
	3 <sup>1/4</sup>	0.148	12d	144	124	115	112	107
	3 <sup>1/2</sup>	0.162	16d	171	147	136	134	128
	4	0.192	20d	205	176	163	160	153
	4 <sup>1/2</sup>	0.207	30d	224	192	178	174	166
	5	0.225	40d	247	212	196	192	183
5 <sup>1/2</sup>	0.244	50d	254	218	202	198	188	
6	0.263	60d	289	248	229	225	214	
16 gage $t_s=0.06''$	2	0.113	6d	88	76	70	69	66
	2 <sup>1/2</sup>	0.131	8d	118	101	94	92	88
	3	0.148	10d	142	122	113	111	106
	3 <sup>1/4</sup>	0.148	12d	142	122	113	111	106
	3 <sup>1/2</sup>	0.162	16d	170	146	135	132	126
	4	0.192	20d	204	175	162	159	151
	4 <sup>1/2</sup>	0.207	30d	224	191	177	174	165
18 gage $t_s=0.048''$	2	0.113	6d	87	75	69	68	65
	2 <sup>1/2</sup>	0.131	8d	117	100	93	91	87
	3	0.148	10d	142	121	112	110	105
	3 <sup>1/4</sup>	0.148	12d	142	121	112	110	105
	3 <sup>1/2</sup>	0.162	16d	170	145	134	132	125

(Continued)

**TABLE 23-III-MM—COMMON WIRE NAIL DESIGN VALUES (Z) FOR SINGLE SHEAR<sup>1,2,3</sup>  
(Two-member) CONNECTIONS WITH ASTM A 446, GRADE A STEEL SIDE PLATE—(Continued)**

STEEL SIDE PLATE	NAIL LENGTH L inches	NAIL DIAMETER D inches	PENNY- WEIGHT	G = 0.67	G = 0.55	G = 0.50	G = 0.49	G = 0.46
				RED OAK	MIXED MAPLE SOUTHERN PINE	DOUGLAS FIR- LARCH	DOUGLAS FIR-LARCH (N)	DOUGLAS FIR (S) HEM-FIR (N)
				Z lbs.	Z lbs.	Z lbs.	Z lbs.	Z lbs.
× 25.4 for mm				× 4.45 for N				
20 gage <i>t<sub>s</sub></i> =0.036"	2	0.113	6d	87	75	69	68	64
	2½	0.131	8d	117	100	92	91	86
	3	0.148	10d	142	121	112	110	105

<sup>1</sup>Tabulated lateral design values (Z) for nailed connections shall be multiplied by all applicable adjustment factors (see Table 23-III-A).

<sup>2</sup>Tabulated lateral design values (Z) are for common wire nails inserted in side grain with nail axis perpendicular to wood fibers, and with the following nail bending yield strength ( $F_{yb}$ )

$F_{yb} = 100,000$  psi (690 N/mm<sup>2</sup>) for 0.113-inch- (2.9 mm) and 0.131-inch-diameter (3.3 mm) common wire nails.

$F_{yb} = 90,000$  psi (621 N/mm<sup>2</sup>) for 0.148-inch- (3.8 mm) and 0.162-inch-diameter (4.1 mm) common wire nails.

$F_{yb} = 80,000$  psi (552 N/mm<sup>2</sup>) for 0.192-inch- (4.9 mm), 0.131-inch- (3.3 mm) and 0.225-inch-diameter (5.7 mm) common wire nails.

$F_{yb} = 70,000$  psi (483 N/mm<sup>2</sup>) for 0.224-inch- (5.7 mm) and 0.263-inch-diameter (6.7 mm) common wire nails.

<sup>3</sup>Tabulated lateral design values (Z) are based on a dowel-bearing strength ( $F_e$ ) of 45,000 psi (310 N/mm<sup>2</sup>) for ASTM A 446, Grade A steel.

(Table continues)

STEEL SIDE PLATE	NAIL LENGTH L inches	NAIL DIAMETER D inches	PENNY- WEIGHT	G = 0.43	G = 0.42	G = 0.37	G = 0.36	G = 0.35
				HEM-FIR	SPRUCE-PINE-FIR	REDWOOD (open grain)	EASTERN SOFTWOODS SPRUCE-PINE-FIR (S) WESTERN CEDARS WESTERN WOODS	NORTHERN SPECIES
				Z lbs.	Z lbs.	Z lbs.	Z lbs.	Z lbs.
× 25.4 for mm				× 4.45 for N				
3 gage $t_s=0.239''$	5 1/2	0.244	50d	218	214	194	191	186
	6	0.263	60d	241	237	214	211	205
7 gage $t_s=0.179''$	4	0.192	20d	168	165	149	146	143
	4 1/2	0.207	30d	179	176	159	156	152
	5	0.225	40d	193	189	171	168	164
	5 1/2	0.244	50d	198	194	175	172	168
	6	0.263	60d	221	217	196	192	187
10 gage $t_s=0.134''$	2	0.113	6d	75	74	67	66	64
	2 1/2	0.131	8d	95	94	85	83	81
	3	0.148	10d	113	111	100	99	96
	3 1/4	0.148	12d	113	111	100	99	96
	3 1/2	0.162	16d	132	129	117	115	112
	4	0.192	20d	155	152	137	135	131
	4 1/2	0.207	30d	167	163	147	145	141
	5	0.225	40d	181	178	160	158	153
	5 1/2	0.244	50d	186	183	165	162	157
6	0.263	60d	210	206	185	182	177	
11 gage $t_s=0.12''$	2	0.113	6d	72	71	64	63	61
	2 1/2	0.131	8d	92	90	82	80	78
	3	0.148	10d	109	107	97	95	93
	3 1/4	0.148	12d	109	107	97	95	93
	3 1/2	0.162	16d	128	126	114	112	109
	4	0.192	20d	151	148	134	132	128
	4 1/2	0.207	30d	163	160	145	142	138
	5	0.225	40d	178	175	158	155	151
	5 1/2	0.244	50d	183	180	162	159	155
6	0.263	60d	207	203	183	180	175	

(Continued)

1994 UNIFORM BUILDING CODE

23-III-MM

TABLE 23-III-MM—COMMON WIRE NAIL DESIGN VALUES (Z) FOR SINGLE SHEAR<sup>1,2,3</sup>  
(Two-member) CONNECTIONS WITH ASTM A 446, GRADE A STEEL SIDE PLATE—(Continued)

STEEL SIDE PLATE	NAIL LENGTH L inches	NAIL DIAMETER D inches	PENNY- WEIGHT	G = 0.43	G = 0.42	G = 0.37	G = 0.36	G = 0.35
				HEM-FIR	SPRUCE-PINE-FIR	REDWOOD (open grain)	EASTERN SOFTWOODS SPRUCE-PINE-FIR (S) WESTERN CEDARS WESTERN WOODS	NORTHERN SPECIES
				Z	Z	Z	Z	Z
				lbs.	lbs.	lbs.	lbs.	lbs.
× 25.4 for mm				× 4.45 for N				
12 gage <i>t<sub>s</sub></i> = 0.105"	2	0.113	6d	69	68	61	60	58
	2½	0.131	8d	89	87	79	78	75
	3	0.148	10d	106	104	94	92	90
	¾	0.148	12d	106	104	94	92	90
	½	0.162	16d	125	123	111	109	106
	4	0.192	20d	148	145	131	129	125
	½	0.207	30d	161	158	142	139	136
	5	0.225	40d	176	173	155	153	148
14 gage <i>t<sub>s</sub></i> = 0.075"	½	0.244	50d	181	177	160	157	152
	6	0.263	60d	205	201	180	177	172
	2	0.113	6d	64	63	56	56	54
	2½	0.131	8d	84	83	74	73	71
	3	0.148	10d	101	99	89	88	85
	¾	0.148	12d	101	99	89	88	85
	½	0.162	16d	120	118	106	104	101
	4	0.192	20d	144	141	127	124	121
14 gage <i>t<sub>s</sub></i> = 0.075"	½	0.207	30d	157	154	138	136	132
	5	0.225	40d	172	169	152	149	145
	½	0.244	50d	177	174	156	153	149
	6	0.263	60d	201	198	177	174	169

16 gage $t_s=0.06''$	2	0.113	6d	62	61	55	54	52
	2 1/2	0.131	8d	83	81	73	71	70
	3	0.148	10d	100	98	88	86	84
	3 1/4	0.148	12d	100	98	88	86	84
	3 1/2	0.162	16d	119	116	105	103	100
	4	0.192	20d	142	140	125	123	120
	4 1/2	0.207	30d	156	153	137	134	131
18 gage $t_s=0.048''$	2	0.113	6d	61	60	54	53	51
	2 1/2	0.131	8d	82	80	72	71	69
	3	0.148	10d	99	97	87	85	83
	3 1/4	0.148	12d	99	97	87	85	83
	3 1/2	0.162	16d	118	116	104	102	99
20 gage $t_s=0.036''$	2	0.113	6d	61	59	53	52	51
	2 1/2	0.131	8d	81	80	71	70	68
	3	0.148	10d	98	96	86	85	82

<sup>1</sup>Tabulated lateral design values ( $Z$ ) for nailed connections shall be multiplied by all applicable adjustment factors (see Table 23-III-A).

<sup>2</sup>Tabulated lateral design values ( $Z$ ) are for common wire nails inserted in side grain with nail axis perpendicular to wood fibers, and with the following nail bending yield strength ( $F_{yb}$ )

$F_{yb} = 100,000$  psi (690 N/mm<sup>2</sup>) for 0.113-inch- (2.9 mm) and 0.131-inch-diameter (3.3 mm) common wire nails.

$F_{yb} = 90,000$  psi (621 N/mm<sup>2</sup>) for 0.148-inch- (3.8 mm) and 0.162-inch-diameter (4.1 mm) common wire nails.

$F_{yb} = 80,000$  psi (552 N/mm<sup>2</sup>) for 0.192-inch- (4.9 mm), 0.131-inch- (3.3 mm) and 0.225-inch-diameter (5.7 mm) common wire nails.

$F_{yb} = 70,000$  psi (483 N/mm<sup>2</sup>) for 0.224-inch- (5.7 mm) and 0.263-inch-diameter (6.7 mm) common wire nails.

<sup>3</sup>Tabulated lateral design values ( $Z$ ) are based on a dowel-bearing strength ( $F_e$ ) of 45,000 psi (310 N/mm<sup>2</sup>) for ASTM A 446, Grade A steel.

TABLE 23-III-NN—THREADED HARDENED-STEEL NAIL DESIGN VALUES (Z) FOR SINGLE SHEAR<sup>1,2,3</sup>  
(Two-member) CONNECTIONS WITH ASTM A 446, GRADE A STEEL SIDE PLATE

STEEL SIDE PLATE	NAIL LENGTH L inches	WIRE DIAMETER D inches	PENNY- WEIGHT	G = 0.67	G = 0.55	G = 0.50	G = 0.49	G = 0.46
				RED OAK	MIXED MAPLE SOUTHERN PINE	DOUGLAS FIR- LARCH	DOUGLAS FIR-LARCH (N)	DOUGLAS FIR (S) HEM-FIR (N)
× 25.4 for mm				Z lbs.	Z lbs.	Z lbs.	Z lbs.	Z lbs.
				× 4.45 for N				
7 gage $t_s=0.179''$	7	0.207	70d	271	235	218	214	205
	8	0.207	80d	271	235	218	214	205
	9	0.207	90d	271	235	218	214	205
10 gage $t_s=0.134''$	2	0.120	6d	125	109	101	99	95
	2 1/2	0.120	8d	125	109	101	99	95
	3	0.135	10d	154	133	124	122	116
	3 1/4	0.135	12d	154	133	124	122	116
	3 1/2	0.148	16d	172	150	139	137	131
	4	0.177	20d	232	200	186	182	174
	4 1/2	0.177	30d	232	200	186	182	174
	5	0.177	40d	232	200	186	182	174
	5 1/2	0.177	50d	232	200	186	182	174
	6	0.177	60d	232	200	186	182	174
	7	0.207	70d	258	223	207	203	194
8	0.207	80d	258	223	207	203	194	
9	0.207	90d	258	223	207	203	194	
11 gage $t_s=0.12''$	2	0.120	6d	122	106	98	96	92
	2 1/2	0.120	8d	122	106	98	96	92
	3	0.135	10d	150	130	121	119	113
	3 1/4	0.135	12d	150	130	121	119	113
	3 1/2	0.148	16d	169	146	136	133	127
	4	0.177	20d	228	197	183	179	171
	4 1/2	0.177	30d	228	197	183	179	171
	5	0.177	40d	228	197	183	179	171
	5 1/2	0.177	50d	228	197	183	179	171
6	0.177	60d	228	197	183	179	171	

12 gage $t_s=0.105''$	2	0.120	6d	118	102	95	93	89
	2 <sup>1</sup> / <sub>2</sub>	0.120	8d	118	102	95	93	89
	3	0.135	10d	147	127	118	116	111
	3 <sup>1</sup> / <sub>4</sub>	0.135	12d	147	127	118	116	111
	3 <sup>1</sup> / <sub>2</sub>	0.148	16d	166	143	133	130	124
	4	0.177	20d	226	194	180	177	169
	4 <sup>1</sup> / <sub>2</sub>	0.177	30d	226	194	180	177	169
	5	0.177	40d	226	194	180	177	169
	5 <sup>1</sup> / <sub>2</sub>	0.177	50d	226	194	180	177	169
6	0.177	60d	226	194	180	177	169	
14 gage $t_s=0.075''$	2	0.120	6d	114	98	91	89	85
	2 <sup>1</sup> / <sub>2</sub>	0.120	8d	114	98	91	89	85
	3	0.135	10d	143	123	114	112	106
	3 <sup>1</sup> / <sub>4</sub>	0.135	12d	143	123	114	112	106
	3 <sup>1</sup> / <sub>2</sub>	0.148	16d	161	139	128	126	120
	4	0.177	20d	222	191	176	173	165
	4 <sup>1</sup> / <sub>2</sub>	0.177	30d	222	191	176	173	165
	5	0.177	40d	222	191	176	173	165
	5 <sup>1</sup> / <sub>2</sub>	0.177	50d	222	191	176	173	165
6	0.177	60d	222	191	176	173	165	
16 gage $t_s=0.06$	2	0.120	6d	112	97	89	88	84
	2 <sup>1</sup> / <sub>2</sub>	0.120	8d	112	97	89	88	84
	3	0.135	10d	142	122	113	110	105
	3 <sup>1</sup> / <sub>4</sub>	0.135	12d	142	122	113	110	105
	3 <sup>1</sup> / <sub>2</sub>	0.148	16d	160	137	127	125	119
	4	0.177	20d	222	190	176	172	164
	4 <sup>1</sup> / <sub>2</sub>	0.177	30d	222	190	176	172	164
	5	0.177	40d	222	190	176	172	164
	5 <sup>1</sup> / <sub>2</sub>	0.177	50d	222	190	176	172	164
6	0.177	60d	222	190	176	172	164	

(Continued)

**TABLE 23-III-NN—THREADED HARDENED-STEEL NAIL DESIGN VALUES (Z) FOR SINGLE SHEAR<sup>1,2,3</sup>  
(Two-member) CONNECTIONS WITH ASTM A 446, GRADE A STEEL SIDE PLATE—(Continued)**

STEEL SIDE PLATE	NAIL LENGTH L Inches	WIRE DIAMETER D Inches	PENNY-WEIGHT	G = 0.67	G = 0.55	G = 0.50	G = 0.49	G = 0.46
				RED OAK	MIXED MAPLE SOUTHERN PINE	DOUGLAS FIR- LARCH	DOUGLAS FIR-LARCH (N)	DOUGLAS FIR (S) HEM-FIR (N)
				Z lbs.	Z lbs.	Z lbs.	Z lbs.	Z lbs.
× 25.4 for mm				× 4.45 for N				
18 gage <i>t<sub>s</sub></i> =0.048"	2	0.120	6d	112	96	89	87	83
	2½	0.120	8d	112	96	89	87	83
	3	0.135	10d	142	121	112	110	105
	3¼	0.135	12d	142	121	112	110	105
	3½	0.148	16d	160	137	127	124	118
20 gage <i>t<sub>s</sub></i> =0.036"	2	0.120	6d	112	96	88	87	83
	2½	0.120	8d	112	96	88	87	83
	3	0.135	10d	142	121	112	110	105

<sup>1</sup>Tabulated lateral design values (Z) for nailed connections shall be multiplied by all applicable adjustment factors (see Table 23-III-A).

<sup>2</sup>Tabulated lateral design values (Z) are for threaded hardened-steel nails inserted in side grain with nail axis perpendicular to wood fibers, and with the following nail bending yield strength ( $F_{yb}$ ):

$F_{yb} = 130,000$  psi (897 N/mm<sup>2</sup>) for 0.120-inch- (3.0 mm) and 0.135-inch-diameter (3.4 mm) threaded hardened-steel nails.

$F_{yb} = 115,000$  psi (793 N/mm<sup>2</sup>) for 0.148-inch- (3.8 mm) and 0.177-inch (4.5 mm) threaded hardened-steel nails.

$F_{yb} = 100,000$  psi (690 N/mm<sup>2</sup>) for 0.207-inch-diameter (5.3 mm) threaded hardened-steel nails.

<sup>3</sup>Tabulated lateral design values (Z) are based on a dowel-bearing strength ( $F_e$ ) of 45,000 psi (310 N/mm<sup>2</sup>) for ASTM A 446, Grade A steel.

(Table continues)

STEEL SIDE PLATE	NAIL LENGTH L inches	WIRE DIAMETER D inches	PENNY- WEIGHT	G = 0.43	G = 0.42	G = 0.37	G = 0.36	G = 0.35
				HEM-FIR	SPRUCE-PINE-FIR	REDWOOD (open grain)	EASTERN SOFTWOODS SPRUCE-PINE-FIR (S) WESTERN CEDARS WESTERN WOODS	NORTHERN SPECIES
× 25.4 for mm				Z lbs.	Z lbs.	Z lbs.	Z lbs.	Z lbs.
				× 4.45 for N				
7 gage <i>t<sub>s</sub></i> =0.179"	7	0.207	70d	194	190	172	169	164
	8	0.207	80d	194	190	172	169	164
	9	0.207	90d	194	190	172	169	164
10 gage <i>t<sub>s</sub></i> =0.134"	2	0.120	6d	90	88	80	78	76
	2½	0.120	8d	90	88	80	78	76
	3	0.135	10d	110	108	98	96	93
	3¼	0.135	12d	110	108	98	96	93
	3½	0.148	16d	123	121	109	107	105
	4	0.177	20d	165	161	146	143	139
	4½	0.177	30d	165	161	146	143	139
	5	0.177	40d	165	161	146	143	139
	5½	0.177	50d	165	161	146	143	139
	6	0.177	60d	165	161	146	143	139
11 gage <i>t<sub>s</sub></i> =0.12"	7	0.207	70d	183	179	162	159	155
	8	0.207	80d	183	179	162	159	155
	9	0.207	90d	183	179	162	159	155
	2	0.120	6d	87	85	77	76	74
	2½	0.120	8d	87	85	77	76	74
	3	0.135	10d	107	105	95	93	91
	3¼	0.135	12d	107	105	95	93	91
	3½	0.148	16d	120	118	107	105	102
	4	0.177	20d	162	159	143	140	137
4½	0.177	30d	162	159	143	140	137	
5	0.177	40d	162	159	143	140	137	
5½	0.177	50d	162	159	143	140	137	
6	0.177	60d	162	159	143	140	137	

(Continued)

TABLE 23-III-NN—THREADED HARDENED-STEEL NAIL DESIGN VALUES (Z) FOR SINGLE SHEAR<sup>1,2,3</sup>  
(Two-member) CONNECTIONS WITH ASTM A 446, GRADE A STEEL SIDE PLATE—(Continued)

STEEL SIDE PLATE	NAIL LENGTH L inches	WIRE DIAMETER D inches	PENNY- WEIGHT	G = 0.43	G = 0.42	G = 0.37	G = 0.36	G = 0.35
				HEM-FIR Z lbs.	SPRUCE-PINE-FIR Z lbs.	REDWOOD (open grain) Z lbs.	EASTERN SOFTWOODS SPRUCE-PINE-FIR (S) WESTERN CEDARS WESTERN WOODS Z lbs.	NORTHERN SPECIES Z lbs.
× 25.4 for mm				× 4.45 for N				
12 gage $t_s=0.105''$	2	0.120	6d	84	83	75	73	71
	2 <sup>1</sup> / <sub>2</sub>	0.120	8d	84	83	75	73	71
	3	0.135	10d	104	102	92	91	88
	3 <sup>1</sup> / <sub>4</sub>	0.135	12d	104	102	92	91	88
	3 <sup>1</sup> / <sub>2</sub>	0.148	16d	117	115	104	102	99
	4	0.177	20d	159	156	140	138	134
	4 <sup>1</sup> / <sub>2</sub>	0.177	30d	159	156	140	138	134
	5	0.177	40d	159	156	140	138	134
14 gage $t_s=0.075''$	5 <sup>1</sup> / <sub>2</sub>	0.177	50d	159	156	140	138	134
	6	0.177	60d	159	156	140	138	134
	2	0.120	6d	80	79	71	70	68
	2 <sup>1</sup> / <sub>2</sub>	0.120	8d	80	79	71	70	68
	3	0.135	10d	100	98	89	87	85
	3 <sup>1</sup> / <sub>4</sub>	0.135	12d	100	98	89	87	85
	3 <sup>1</sup> / <sub>2</sub>	0.148	16d	113	111	100	98	95
	4	0.177	20d	155	152	137	134	131
14 gage $t_s=0.075''$	4 <sup>1</sup> / <sub>2</sub>	0.177	30d	155	152	137	134	131
	5	0.177	40d	155	152	137	134	131
	5 <sup>1</sup> / <sub>2</sub>	0.177	50d	155	152	137	134	131
	6	0.177	60d	155	152	137	134	131

16 gage $t_s=0.06''$	2	0.120	6d	79	77	69	68	66
	2 1/2	0.120	8d	79	77	69	68	66
	3	0.135	10d	99	97	87	86	83
	3 1/4	0.135	12d	99	97	87	86	83
	3 1/2	0.148	16d	112	110	98	97	94
	4	0.177	20d	154	151	136	133	130
	4 1/2	0.177	30d	154	151	136	133	130
	5	0.177	40d	154	151	136	133	130
18 gage $t_s=0.048''$	5 1/2	0.177	50d	154	151	136	133	130
	6	0.177	60d	154	151	136	133	130
	2	0.120	6d	78	76	69	67	66
	2 1/2	0.120	8d	78	76	69	67	66
	3	0.135	10d	98	97	87	85	83
20 gage $t_s=0.036''$	3 1/4	0.135	12d	98	97	87	85	83
	3 1/2	0.148	16d	111	109	98	96	93
	2	0.120	6d	78	76	68	67	65
	2 1/2	0.120	8d	78	76	68	67	65
	3	0.135	10d	98	96	86	85	82

<sup>1</sup>Tabulated lateral design values (Z) for nailed connections shall be multiplied by all applicable adjustment factors (see Table 23-III-A).

<sup>2</sup>Tabulated lateral design values (Z) are for threaded hardened-steel nails inserted in side grain with nail axis perpendicular to wood fibers, and with the following nail bending yield strength ( $F_{yb}$ ):

$F_{yb} = 130,000$  psi (897 N/mm<sup>2</sup>) for 0.120-inch- (3.0 mm) and 0.135-inch-diameter (3.4 mm) threaded hardened-steel nails.

$F_{yb} = 115,000$  psi (793 N/mm<sup>2</sup>) for 0.148-inch- (3.8 mm) and 0.177-inch (4.5 mm) threaded hardened-steel nails.

$F_{yb} = 100,000$  psi (690 N/mm<sup>2</sup>) for 0.207-inch-diameter (5.3 mm) threaded hardened-steel nails.

<sup>3</sup>Tabulated lateral design values (Z) are based on a dowel-bearing strength ( $F_e$ ) of 45,000 psi (310 N/mm<sup>2</sup>) for ASTM A 446, Grade A steel.

TABLE 23-III-00—COMMON WIRE SPIKE DESIGN VALUES (Z) FOR SINGLE SHEAR<sup>1,2,3</sup>  
(Two-member) CONNECTIONS WITH ASTM A 446, GRADE A STEEL SIDE PLATE

STEEL SIDE PLATE	SPIKE LENGTH L Inches	SPIKE DIAMETER D Inches	PENNY-WEIGHT	G = 0.67	G = 0.55	G = 0.50	G = 0.49	G = 0.46
				RED OAK	MIXED MAPLE SOUTHERN PINE	DOUGLAS FIR-LARCH	DOUGLAS FIR-LARCH (N)	DOUGLAS FIR (S) HEM-FIR (N)
				Z lbs.	Z lbs.	Z lbs.	Z lbs.	Z lbs.
× 25.4 for mm				× 4.45 for N				
3 gage <i>t<sub>s</sub></i> =0.239"	4 1/2	0.244	30d	301	263	245	241	230
	5	0.263	40d	334	291	271	266	255
	5 1/2	0.283	50d	359	312	291	286	273
	6	0.283	60d	359	312	291	286	273
	7	0.312	5/16	423	367	342	336	321
	8 1/2	0.375	3/8	523	454	423	415	397
7 gage <i>t<sub>s</sub></i> =0.179"	3	0.192	10d	233	203	189	185	177
	3 1/4	0.192	12d	233	203	189	185	177
	3 1/2	0.207	16d	249	217	202	198	189
	4	0.225	20d	269	234	217	213	204
	4 1/2	0.244	30d	276	240	223	219	209
	5	0.263	40d	309	268	249	245	234
	5 1/2	0.283	50d	332	288	267	262	251
	6	0.283	60d	332	288	267	262	251
	7	0.312	5/16	396	343	318	313	299
8 1/2	0.375	3/8	492	426	395	388	371	
10 gage <i>t<sub>s</sub></i> =0.134"	3	0.192	10d	217	188	174	171	164
	3 1/4	0.192	12d	217	188	174	171	164
	3 1/2	0.207	16d	234	203	188	185	176
	4	0.225	20d	256	221	205	201	192
	4 1/2	0.244	30d	262	227	210	206	197
	5	0.263	40d	296	256	237	233	222
	5 1/2	0.283	50d	318	274	254	250	238
	6	0.283	60d	318	274	254	250	238
	7	0.312	5/16	383	330	306	300	287
8 1/2	0.375	3/8	478	411	381	374	357	

11 gage $t_s=0.12''$	3	0.192	10d	213	184	171	168	160
	3 <sup>1</sup> / <sub>4</sub>	0.192	12d	213	184	171	168	160
	3 <sup>1</sup> / <sub>2</sub>	0.207	16d	231	199	185	181	173
	4	0.225	20d	252	218	202	198	189
	4 <sup>1</sup> / <sub>2</sub>	0.244	30d	259	224	207	204	194
	5	0.263	40d	294	253	234	230	220
	5 <sup>1</sup> / <sub>2</sub>	0.283	50d	315	271	251	247	235
	6	0.283	60d	315	271	251	247	235
	7	0.312	5 <sup>5</sup> / <sub>16</sub>	380	327	303	297	284
8 <sup>1</sup> / <sub>2</sub>	0.375	3 <sup>3</sup> / <sub>8</sub>	475	408	378	371	354	
12 gage $t_s=0.105''$	3	0.192	10d	209	181	168	164	157
	3 <sup>1</sup> / <sub>4</sub>	0.192	12d	209	181	168	164	157
	3 <sup>1</sup> / <sub>2</sub>	0.207	16d	228	196	182	178	170
	4	0.225	20d	250	215	199	196	187
	4 <sup>1</sup> / <sub>2</sub>	0.244	30d	257	221	205	201	192
	5	0.263	40d	291	251	232	228	217
	5 <sup>1</sup> / <sub>2</sub>	0.283	50d	312	269	249	244	233
	6	0.283	60d	312	269	249	244	233
	7	0.312	5 <sup>5</sup> / <sub>16</sub>	378	325	301	295	281
8 <sup>1</sup> / <sub>2</sub>	0.375	3 <sup>3</sup> / <sub>8</sub>	473	406	376	368	351	
14 gage $t_s=0.075''$	3	0.192	10d	205	176	163	160	153
	3 <sup>1</sup> / <sub>4</sub>	0.192	12d	205	176	163	160	153
	3 <sup>1</sup> / <sub>2</sub>	0.207	16d	224	192	178	174	166
	4	0.225	20d	247	212	196	192	183
	4 <sup>1</sup> / <sub>2</sub>	0.244	30d	254	218	202	198	188
	5	0.263	40d	289	248	229	225	214
	5 <sup>1</sup> / <sub>2</sub>	0.283	50d	310	266	246	241	230
	6	0.283	60d	310	266	246	241	230
	7	0.312	5 <sup>5</sup> / <sub>16</sub>	377	323	298	292	279
8 <sup>1</sup> / <sub>2</sub>	0.375	3 <sup>3</sup> / <sub>8</sub>	472	404	373	366	348	
16 gage $t_s=0.06''$	3	0.192	10d	204	175	162	159	151
	3 <sup>1</sup> / <sub>4</sub>	0.192	12d	204	175	162	159	151
	3 <sup>1</sup> / <sub>2</sub>	0.207	16d	224	191	177	174	165

(Continued)

TABLE 23-III-00—COMMON WIRE SPIKE DESIGN VALUES (Z) FOR SINGLE SHEAR<sup>1,2,3</sup>  
(Two-member) CONNECTIONS WITH ASTM A 446, GRADE A STEEL SIDE PLATE—(Continued)

STEEL SIDE PLATE	SPIKE LENGTH L inches	SPIKE DIAMETER D inches	PENNY-WEIGHT	G = 0.43	G = 0.42	G = 0.37	G = 0.36	G = 0.35
				HEM-FIR	SPRUCE-PINE-FIR	REDWOOD (open grain)	EASTERN SOFTWOODS SPRUCE-PINE-FIR(S) WESTERN CEDARS WESTERN WOODS	NORTHERN SPECIES
				Z lbs.	Z lbs.	Z lbs.	Z lbs.	Z lbs.
× 25.4 for mm				× 4.45 for N				
3 gage <i>t<sub>s</sub></i> =0.239"	4 1/2	0.244	30d	218	214	194	191	186
	5	0.263	40d	241	237	214	211	205
	5 1/2	0.283	50d	259	254	230	226	220
	6	0.283	60d	259	254	230	226	220
	7	0.312	5/16	304	298	270	265	258
	8 1/2	0.375	3/8	375	368	333	328	319
7 gage <i>t<sub>s</sub></i> =0.179"	3	0.192	10d	168	165	149	146	143
	3 1/4	0.192	12d	168	165	149	146	143
	3 1/2	0.207	16d	179	176	159	156	152
	4	0.225	20d	193	189	171	168	164
	4 1/2	0.244	30d	198	194	175	172	168
	5	0.263	40d	221	217	196	192	187
	5 1/2	0.283	50d	237	233	210	206	201
	6	0.283	60d	237	233	210	206	201
	7	0.312	5/16	282	277	250	245	239
8 1/2	0.375	3/8	350	344	310	305	296	

10 gage $t_s=0.134''$	3	0.192	10d	155	152	137	135	131
	3 <sup>1</sup> / <sub>4</sub>	0.192	12d	155	152	137	135	131
	3 <sup>1</sup> / <sub>2</sub>	0.207	16d	167	163	147	145	141
	4	0.225	20d	181	178	160	158	153
	4 <sup>1</sup> / <sub>2</sub>	0.244	30d	186	183	165	162	157
	5	0.263	40d	210	206	185	182	177
	5 <sup>1</sup> / <sub>2</sub>	0.283	50d	225	221	199	195	190
	6	0.283	60d	225	221	199	195	190
	7	0.312	5 <sup>5</sup> / <sub>16</sub>	270	265	239	234	228
8 <sup>1</sup> / <sub>2</sub>	0.375	3 <sup>3</sup> / <sub>8</sub>	337	330	297	292	284	
11 gage $t_s=0.12''$	3	0.192	10d	151	148	134	132	128
	3 <sup>1</sup> / <sub>4</sub>	0.192	12d	151	148	134	132	128
	3 <sup>1</sup> / <sub>2</sub>	0.207	16d	163	160	145	142	138
	4	0.225	20d	178	175	158	155	151
	4 <sup>1</sup> / <sub>2</sub>	0.244	30d	183	180	162	159	155
	5	0.263	40d	207	203	183	180	175
	5 <sup>1</sup> / <sub>2</sub>	0.283	50d	222	218	196	193	187
	6	0.283	60d	222	218	196	193	187
	7	0.312	5 <sup>5</sup> / <sub>16</sub>	267	262	236	232	225
8 <sup>1</sup> / <sub>2</sub>	0.375	3 <sup>3</sup> / <sub>8</sub>	334	327	294	289	281	
12 gage $t_s=0.105''$	3	0.192	10d	148	145	131	129	125
	3 <sup>1</sup> / <sub>4</sub>	0.192	12d	148	145	131	129	125
	3 <sup>1</sup> / <sub>2</sub>	0.207	16d	161	158	142	139	136
	4	0.225	20d	176	173	155	153	148
	4 <sup>1</sup> / <sub>2</sub>	0.244	30d	181	177	160	157	152
	5	0.263	40d	205	201	180	177	172
	5 <sup>1</sup> / <sub>2</sub>	0.283	50d	219	215	193	190	185
	6	0.283	60d	219	215	193	190	185
	7	0.312	5 <sup>5</sup> / <sub>16</sub>	265	260	234	229	223
8 <sup>1</sup> / <sub>2</sub>	0.375	3 <sup>3</sup> / <sub>8</sub>	331	324	291	286	279	

(Continued)

**TABLE 23-III-00—COMMON WIRE SPIKE DESIGN VALUES (Z) FOR SINGLE SHEAR<sup>1,2,3</sup>  
(Two-member) CONNECTIONS WITH ASTM A 446, GRADE A STEEL SIDE PLATE—(Continued)**

STEEL SIDE PLATE	SPIKE LENGTH L Inches	SPIKE DIAMETER D Inches	PENNY- WEIGHT	G = 0.43	G = 0.42	G = 0.37	G = 0.36	G = 0.35
				HEM-FIR	SPRUCE-PINE-FIR	REDWOOD (open grain)	EASTERN SOFTWOODS SPRUCE-PINE-FIR(S) WESTERN CEDARS WESTERN WOODS	NORTHERN SPECIES
× 25.4 for mm				Z	Z	Z	Z	Z
				lbs.	lbs.	lbs.	lbs.	lbs.
				× 4.45 for N				
14 gage $t_s=0.075''$	3	0.192	10d	144	141	127	124	121
	3 <sup>1</sup> / <sub>4</sub>	0.192	12d	144	141	127	124	121
	3 <sup>1</sup> / <sub>2</sub>	0.207	16d	157	154	138	136	132
	4	0.225	20d	172	169	152	149	145
	4 <sup>1</sup> / <sub>2</sub>	0.244	30d	177	174	156	153	149
	5	0.263	40d	201	198	177	174	169
	5 <sup>1</sup> / <sub>2</sub>	0.283	50d	216	212	190	187	182
	6	0.283	60d	216	212	190	187	182
	7	0.312	<sup>5</sup> / <sub>16</sub>	262	257	230	226	220
8 <sup>1</sup> / <sub>2</sub>	0.375	<sup>3</sup> / <sub>8</sub>	328	321	288	283	275	
16 gage $t_s=0.06''$	3	0.192	10d	142	140	125	123	120
	3 <sup>1</sup> / <sub>4</sub>	0.192	12d	142	140	125	123	120
	3 <sup>1</sup> / <sub>2</sub>	0.207	16d	156	153	137	134	131

<sup>1</sup>Tabulated lateral design values (Z) for spike connections shall be multiplied by all applicable adjustment factors (see Table 23-III-A).

<sup>2</sup>Tabulated lateral design values (Z) are for common wire spikes inserted in side grain with spike axis perpendicular to wood fibers, and with the following spike bending yield strength ( $F_{yb}$ ):

$F_{yb} = 80,000$  psi (552 N/mm<sup>2</sup>) for 0.192-inch- (4.9 mm), 0.207-inch- (5.3 mm) and 0.225-inch-diameter (5.7 mm) common wire spikes.

$F_{yb} = 70,000$  psi (483 N/mm<sup>2</sup>) for 0.224-inch (5.7 mm) and 0.263-inch (6.7 mm) common wire spikes.

$F_{yb} = 60,000$  psi (414 N/mm<sup>2</sup>) for 0.283-inch- (7.2 mm) and <sup>5</sup>/<sub>16</sub>-inch-diameter (7.9 mm) common wire spikes.

$F_{yb} = 45,000$  psi (310 N/mm<sup>2</sup>) for <sup>3</sup>/<sub>8</sub>-inch-diameter (9.5 mm) common wire spikes.

<sup>3</sup>Tabulated lateral design values (Z) are based on a dowel-bearing strength ( $F_e$ ) of 45,000 psi (310 N/mm<sup>2</sup>) for ASTM A 446, Grade A steel.

TABLE 23-III-PP

ROOF SLOPE	PERCENTAGE OF ALLOWABLE CONNECTOR VALUE TO BE USED
Less than 3 in 12 (25 %)	85 percent
3 in 12 (25 %), less than 4 in 12 (33.3 %)	80 percent
4 in 12 (33.3 %), less than 5 in 12 (41.7 %)	75 percent
5 in 12 (41.7 %), to include 5½ in 12 (45.8 %)	70 percent
Greater than 5½ in 12 (45.8 %)	65 percent

TABLE 23-III-QQ—GROUPING OF SPECIES FOR DETERMINING ALLOWABLE LOADS FOR LAG SCREWS, NAILS, SPIKES, WOOD SCREWS, DRIFT BOLTS

GROUP	SPECIES OF WOOD	SPECIFIC (G) <sup>1</sup>
I	Ash, commercial white	0.62
	Mixed hardwoods	0.71
	Mixed oak	0.71
	Northern red oak	0.68
	Red oak	0.68
	White oak	0.74
II	Douglas fir-larch <sup>2</sup>	0.51
	Mixed maple	0.59
	Red maple	0.57
	Southern pine	0.55
	Sweetgum and tupelo	0.54
	Virginia pine-pond pine	0.54
III	California redwood (close grain)	0.42
	Douglas fir, south	0.48
	Eastern hemlock	0.43
	Eastern hemlock—tamarack <sup>2</sup>	0.45
	Eastern softwoods	0.42
	Eastern spruce	0.43
	Engelmann spruce-lodgepole pine (MSR) <sup>3</sup>	0.46
	Hem-fir <sup>2</sup>	0.42
	Lodgepole pine	0.44
	Mountain hemlock	0.47
	Mountain hemlock-hem-fir	0.44
	Northern aspen	0.42
	Northern pine	0.46
	Ponderosa pine <sup>3</sup>	0.49
	Ponderosa pine-sugar pine	0.42
	Red pine	0.42
	Sitka spruce	0.43
	Southern cypress	0.48
Spruce-pine-fir	0.42	
Western hemlock	0.48	
Yellow poplar	0.46	

(Continued)

**TABLE 23-III-QQ—GROUPING OF SPECIES FOR DETERMINING ALLOWABLE LOADS FOR LAG SCREWS, NAILS, SPIKES, WOOD SCREWS, DRIFT BOLTS—(Continued)**

GROUP	SPECIES OF WOOD	SPECIFIC (G) <sup>1</sup>
IV	Aspen .....	0.40
	Balsam fir .....	0.38
	Black cottonwood .....	0.33
	California redwood (open grain) .....	0.37
	Coast sitka spruce .....	0.39
	Coast species .....	0.39
	Cottonwood, eastern .....	0.41
	Eastern white pine <sup>2</sup> .....	0.38
	Eastern woods .....	0.38
	Engelmann spruce-alpine fir .....	0.36
	Idaho white pine .....	0.40
	Northern species .....	0.35
	Northern white cedar .....	0.31
	West coast woods (mixed species) .....	0.35
	Western cedars <sup>2</sup> .....	0.35
	Western white pine .....	0.40
	White woods (western woods) .....	0.35

<sup>1</sup>Based on weight and volume when oven dry.

<sup>2</sup>Also applies when species name includes the designation "North."

<sup>3</sup>Applies to grades of 1650F<sub>b</sub> - 1.5E and higher machine-stress-rated (MSR) lumber.

**TABLE 23-III-RR—MANUFACTURING TOLERANCE FOR FINISHED TRUSS UNITS**

PART I			
Pitched <sup>1</sup> Truss Units			
Length <sup>2</sup> of Finished Truss Unit	Variance from Design Dimensions	Height <sup>3</sup> of Finished Truss Unit	Variance from Design Dimensions
× 304.8 for mm	× 25.4 for mm	× 304.8 for mm	× 25.4 for mm
Up to 30 feet	1/4 inch	Up to 5 feet	1/8 inch
30 to 50 feet	3/8 inch	5 to 12 feet	1/4 inch
Over 50 feet	1/2 inch	Over 12 feet	3/8 inch
PART II			
Parallel Chord <sup>4</sup> Truss Units			
Up to 30 feet	1/4 inch	Up to 24 inches	1/8 inch
Over 30 feet	3/8 inch	24 to 60 inches	1/4 inch
		Over 60 inches	3/8 inch

<sup>1</sup>Pitched trusses are defined as having differences in slopes between top and bottom chords greater than 1:12.

<sup>2</sup>Length, for fabrication tolerance purposes, is the overall length of the truss unit, excluding overhangs or extensions.

<sup>3</sup>Height, for fabrication tolerance purposes, is the overall height of the truss unit measured from the top of the top chord to the bottom of the bottom chord at the highest point of the truss, excluding projections above the top chord and below the bottom chord, overhangs and extensions.

<sup>4</sup>Parallel chord trusses are defined as having differences in slopes between top and bottom chords less than or equal to 1:12.

TABLE 23-III-SS—FORMULAS FOR DETERMINING  $F'_c$ <sup>1, 2, 3</sup>

$L'/d$ RATIO	VISUALLY GRADED LUMBER	MACHINE-STRESS-RATED LUMBER
$11 < L'/d < K$	$F'_c = F_c$	$F'_c = F_c$
$11 < L'/d < K$	$F'_c = F_c \left[ 1 - \frac{1}{3} \left( \frac{L'/d}{K} \right)^4 \right]$ <p style="text-align: center;">where <math>K = 0.671 \sqrt{\frac{E}{F_c}}</math></p>	$F'_c = F_c \left[ 1 - \frac{1}{3} \left( \frac{L'/d}{K} \right)^4 \right]$ <p style="text-align: center;">where <math>K = 0.792 \sqrt{\frac{E}{F_c}}</math></p>
$L'/d > K$	$F'_c = \frac{0.30E}{(L'/d)^2}$	$F'_c = \frac{0.418E}{(L'/d)^2}$

<sup>1</sup>See Table 23-III-TT for  $L'$ .

<sup>2</sup>See U.B.C. Section 2307.

<sup>3</sup>Duration of load adjustment factors apply only to  $F_c$ . Values of  $F_c$  and  $E$  may be subject to other appropriate modification for conditions of use or types of treatment. Calculated values,  $F'_c$ , are not subject to further adjustment for these conditions.

TABLE 23-III-TT—EFFECTIVE LENGTH IN BUCKLING

POSSIBLE CRITICAL $L'/d$		
Member	Effective Dimension ( $d$ )	Effective Buckling Length ( $L$ )
Chords	$h$	1 or 2 panels      1.00 $L$ 3 or more panels      0.55 $L$
	$b$	$L_p$ for top chord <sup>1</sup> $L_p$ for bottom chord <sup>1</sup>
Webs	$h$	0.8 $L_w$

<sup>1</sup>Where sheathing or ceiling material is nailed directly to a compression chord, lateral support of the axis may be assumed to be continuous and  $L'/d = L_p/b$  may be neglected.

TABLE 23-III-UU—TYPICAL DIMENSIONS FOR STANDARD LAG SCREWS

*D*—Unthreaded shank diameter.  
*D<sub>r</sub>*—Root diameter of threaded portion.  
*W*—Width of head across flats.  
*H*—Height of head.

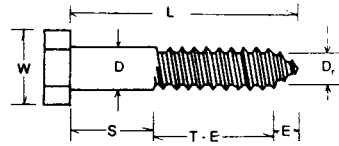

*S*—Unthreaded shank length.  
*T*—Thread length<sup>1</sup>.  
*E*—Length of tapered tip.  
*N*—Number of threads per inch (25 mm).

NOMINAL LENGTH, L (inches) × 25.4 for mm		UNTHREADED SHANK DIAMETER, D (inches) × 25.4 for mm										
		1/4"	5/16"	3/8"	7/16"	1/2"	5/8"	3/4"	7/8"	1"	1 1/8"	1 1/4"
		<i>D<sub>r</sub></i>	0.173	0.227	0.265	0.328	0.371	0.471	0.579	0.683	0.780	0.887
<i>E</i>	5/32	3/16	7/32	9/32	5/16	13/32	1/2	19/32	11/16	25/32	7/8	
<i>H</i>	11/64	7/32	1/4	19/64	11/32	27/64	1/2	37/64	43/64	3/4	27/32	
<i>W</i>	7/16	1/2	9/16	5/8	3/4	15/16	1 1/8	1 5/16	1 1/2	1 11/16	1 7/8	
<i>N</i>	10	9	7	7	6	5	4 1/2	4	3 1/2	3 1/4	3 1/4	
1	<i>S</i>	1/4	1/4	1/4	1/4	1/4						
	<i>T</i>	3/4	3/4	3/4	3/4	3/4						
	<i>T-E</i>	19/32	9/16	17/32	15/32	7/16						
1 1/2	<i>S</i>	1/4	1/4	1/4	1/4	1/4						
	<i>T</i>	1 1/4	1 1/4	1 1/4	1 1/4	1 1/4						
	<i>T-E</i>	1 3/32	1 1/16	1 1/32	31/32	15/16						
2	<i>S</i>	1/2	1/2	1/2	1/2	1/2	1/2					
	<i>T</i>	1 1/2	1 1/2	1 1/2	1 1/2	1 1/2	1 1/2					
	<i>T-E</i>	1 11/32	1 5/16	1 9/32	1 7/32	1 3/16	1 3/32					
2 1/2	<i>S</i>	3/4	3/4	3/4	3/4	3/4	3/4					
	<i>T</i>	1 3/4	1 3/4	1 3/4	1 3/4	1 3/4	1 3/4					
	<i>T-E</i>	1 19/32	1 9/16	1 17/32	1 15/32	1 7/16	1 11/32					
3	<i>S</i>	1	1	1	1	1	1	1	1	1		
	<i>T</i>	2	2	2	2	2	2	2	2	2		
	<i>T-E</i>	1 27/32	1 13/16	1 25/32	1 23/32	1 11/16	1 19/32	1 1/2	1 13/32	1 5/16		
4	<i>S</i>	1 1/2	1 1/2	1 1/2	1 1/2	1 1/2	1 1/2	1 1/2	1 1/2	1 1/2	1 1/2	
	<i>T</i>	2 1/2	2 1/2	2 1/2	2 1/2	2 1/2	2 1/2	2 1/2	2 1/2	2 1/2	2 1/2	
	<i>T-E</i>	2 11/32	2 5/16	2 9/32	2 7/32	2 3/16	2 3/32	2	1 29/32	1 13/16	1 23/32	
5	<i>S</i>	2	2	2	2	2	2	2	2	2	2	
	<i>T</i>	3	3	3	3	3	3	3	3	3	3	
	<i>T-E</i>	2 27/32	2 13/16	2 25/32	2 23/32	2 11/16	2 19/32	2 1/2	2 13/32	2 5/16	2 7/32	

6	S	2 <sup>1</sup> / <sub>2</sub>	2 <sup>1</sup> / <sub>2</sub>	2 <sup>1</sup> / <sub>2</sub>	2 <sup>1</sup> / <sub>2</sub>	2 <sup>1</sup> / <sub>2</sub>	2 <sup>1</sup> / <sub>2</sub>	2 <sup>1</sup> / <sub>2</sub>	2 <sup>1</sup> / <sub>2</sub>	2 <sup>1</sup> / <sub>2</sub>	2 <sup>1</sup> / <sub>2</sub>	2 <sup>1</sup> / <sub>2</sub>	2 <sup>1</sup> / <sub>2</sub>
	T	3 <sup>1</sup> / <sub>2</sub>	3 <sup>1</sup> / <sub>2</sub>	3 <sup>1</sup> / <sub>2</sub>	3 <sup>1</sup> / <sub>2</sub>	3 <sup>1</sup> / <sub>2</sub>	3 <sup>1</sup> / <sub>2</sub>	3 <sup>1</sup> / <sub>2</sub>	3 <sup>1</sup> / <sub>2</sub>	3 <sup>1</sup> / <sub>2</sub>	3 <sup>1</sup> / <sub>2</sub>	3 <sup>1</sup> / <sub>2</sub>	3 <sup>1</sup> / <sub>2</sub>
	T-E	3 <sup>11</sup> / <sub>32</sub>	3 <sup>5</sup> / <sub>16</sub>	3 <sup>9</sup> / <sub>32</sub>	3 <sup>7</sup> / <sub>32</sub>	3 <sup>3</sup> / <sub>16</sub>	3 <sup>3</sup> / <sub>32</sub>	3	2 <sup>29</sup> / <sub>32</sub>	2 <sup>13</sup> / <sub>16</sub>	2 <sup>23</sup> / <sub>32</sub>	2 <sup>5</sup> / <sub>8</sub>	
7	S	3	3	3	3	3	3	3	3	3	3	3	3
	T	4	4	4	4	4	4	4	4	4	4	4	4
	T-E	3 <sup>27</sup> / <sub>32</sub>	3 <sup>13</sup> / <sub>16</sub>	3 <sup>25</sup> / <sub>32</sub>	3 <sup>23</sup> / <sub>32</sub>	3 <sup>11</sup> / <sub>16</sub>	3 <sup>19</sup> / <sub>32</sub>	3 <sup>1</sup> / <sub>2</sub>	3 <sup>13</sup> / <sub>32</sub>	3 <sup>5</sup> / <sub>16</sub>	3 <sup>7</sup> / <sub>32</sub>	3 <sup>1</sup> / <sub>8</sub>	
8	S	3 <sup>1</sup> / <sub>2</sub>	3 <sup>1</sup> / <sub>2</sub>	3 <sup>1</sup> / <sub>2</sub>	3 <sup>1</sup> / <sub>2</sub>	3 <sup>1</sup> / <sub>2</sub>	3 <sup>1</sup> / <sub>2</sub>	3 <sup>1</sup> / <sub>2</sub>	3 <sup>1</sup> / <sub>2</sub>	3 <sup>1</sup> / <sub>2</sub>	3 <sup>1</sup> / <sub>2</sub>	3 <sup>1</sup> / <sub>2</sub>	3 <sup>1</sup> / <sub>2</sub>
	T	4 <sup>1</sup> / <sub>2</sub>	4 <sup>1</sup> / <sub>2</sub>	4 <sup>1</sup> / <sub>2</sub>	4 <sup>1</sup> / <sub>2</sub>	4 <sup>1</sup> / <sub>2</sub>	4 <sup>1</sup> / <sub>2</sub>	4 <sup>1</sup> / <sub>2</sub>	4 <sup>1</sup> / <sub>2</sub>	4 <sup>1</sup> / <sub>2</sub>	4 <sup>1</sup> / <sub>2</sub>	4 <sup>1</sup> / <sub>2</sub>	4 <sup>1</sup> / <sub>2</sub>
	T-E	4 <sup>11</sup> / <sub>32</sub>	4 <sup>5</sup> / <sub>16</sub>	4 <sup>9</sup> / <sub>32</sub>	4 <sup>7</sup> / <sub>32</sub>	4 <sup>3</sup> / <sub>16</sub>	4 <sup>3</sup> / <sub>32</sub>	4	3 <sup>29</sup> / <sub>32</sub>	3 <sup>13</sup> / <sub>16</sub>	3 <sup>23</sup> / <sub>32</sub>	3 <sup>5</sup> / <sub>8</sub>	
9	S	4	4	4	4	4	4	4	4	4	4	4	4
	T	5	5	5	5	5	5	5	5	5	5	5	5
	T-E	4 <sup>27</sup> / <sub>32</sub>	4 <sup>13</sup> / <sub>16</sub>	4 <sup>25</sup> / <sub>32</sub>	4 <sup>23</sup> / <sub>32</sub>	4 <sup>11</sup> / <sub>16</sub>	4 <sup>19</sup> / <sub>32</sub>	4 <sup>1</sup> / <sub>2</sub>	4 <sup>13</sup> / <sub>32</sub>	4 <sup>5</sup> / <sub>16</sub>	4 <sup>7</sup> / <sub>32</sub>	4 <sup>1</sup> / <sub>8</sub>	
10	S	4 <sup>1</sup> / <sub>2</sub>	4 <sup>1</sup> / <sub>2</sub>	4 <sup>1</sup> / <sub>2</sub>	4 <sup>1</sup> / <sub>2</sub>	4 <sup>1</sup> / <sub>2</sub>	4 <sup>1</sup> / <sub>2</sub>	4 <sup>1</sup> / <sub>2</sub>	4 <sup>1</sup> / <sub>2</sub>	4 <sup>1</sup> / <sub>2</sub>	4 <sup>1</sup> / <sub>2</sub>	4 <sup>1</sup> / <sub>2</sub>	4 <sup>1</sup> / <sub>2</sub>
	T	5 <sup>1</sup> / <sub>2</sub>	5 <sup>1</sup> / <sub>2</sub>	5 <sup>1</sup> / <sub>2</sub>	5 <sup>1</sup> / <sub>2</sub>	5 <sup>1</sup> / <sub>2</sub>	5 <sup>1</sup> / <sub>2</sub>	5 <sup>1</sup> / <sub>2</sub>	5 <sup>1</sup> / <sub>2</sub>	5 <sup>1</sup> / <sub>2</sub>	5 <sup>1</sup> / <sub>2</sub>	5 <sup>1</sup> / <sub>2</sub>	5 <sup>1</sup> / <sub>2</sub>
	T-E	5 <sup>11</sup> / <sub>32</sub>	5 <sup>5</sup> / <sub>16</sub>	5 <sup>9</sup> / <sub>32</sub>	5 <sup>7</sup> / <sub>32</sub>	5 <sup>3</sup> / <sub>16</sub>	5 <sup>3</sup> / <sub>32</sub>	5	4 <sup>29</sup> / <sub>32</sub>	4 <sup>13</sup> / <sub>16</sub>	4 <sup>23</sup> / <sub>32</sub>	4 <sup>5</sup> / <sub>8</sub>	
11	S	5	5	5	5	5	5	5	5	5	5	5	5
	T	6	6	6	6	6	6	6	6	6	6	6	6
	T-E	5 <sup>27</sup> / <sub>32</sub>	5 <sup>13</sup> / <sub>16</sub>	5 <sup>25</sup> / <sub>32</sub>	5 <sup>23</sup> / <sub>32</sub>	5 <sup>11</sup> / <sub>16</sub>	5 <sup>19</sup> / <sub>32</sub>	5 <sup>1</sup> / <sub>2</sub>	5 <sup>13</sup> / <sub>32</sub>	5 <sup>5</sup> / <sub>16</sub>	5 <sup>7</sup> / <sub>32</sub>	5 <sup>1</sup> / <sub>8</sub>	
12	S	6	6	6	6	6	6	6	6	6	6	6	6
	T	6	6	6	6	6	6	6	6	6	6	6	6
	T-E	5 <sup>27</sup> / <sub>32</sub>	5 <sup>13</sup> / <sub>16</sub>	5 <sup>25</sup> / <sub>32</sub>	5 <sup>23</sup> / <sub>32</sub>	5 <sup>11</sup> / <sub>16</sub>	5 <sup>19</sup> / <sub>32</sub>	5 <sup>1</sup> / <sub>2</sub>	5 <sup>13</sup> / <sub>32</sub>	5 <sup>5</sup> / <sub>16</sub>	5 <sup>7</sup> / <sub>32</sub>	5 <sup>1</sup> / <sub>8</sub>	

<sup>1</sup>Thread length (T) for intermediate nominal lag screw lengths (L) is 6 inches (152 mm), or one half the nominal lag screw length plus 0.5 inch (13 mm), whichever is less.

TABLE 23-III-VV—TYPICAL DIMENSIONS FOR SPLIT RING AND SHEAR PLATE CONNECTORS

	× 25.4 for mm	
SPLIT RINGS	2 1/2"	4"
Split ring		
Inside diameter at center when closed	2.500"	4.000"
Thickness of metal at center	0.163"	0.193"
Depth of metal (width of ring)	0.750"	1.000"
Groove		
Inside diameter	2.56"	4.08"
Width	0.18"	0.21"
Depth	0.375"	0.50"
Bolt hole diameter in timber members	9/16"	13/16"
Washers, standard		
Round, cast or malleable iron, diameter	2 1/8"	3"
Round, wrought iron (minimum)		
Diameter	1 3/8"	2"
Thickness	3/32"	5/32"
Square plate		
Length of side	2"	3"
Thickness	1/8"	3/16"
	× 645 for mm <sup>2</sup>	
Projected area: portion of one split ring within member	1.10 in. <sup>2</sup>	2.24 in. <sup>2</sup>

SHEAR PLATES	× 25.4 for mm			
	2 <sup>5</sup> / <sub>8</sub> "	2 <sup>5</sup> / <sub>8</sub> "	4"	4"
Shear plate	Pressed	Light	Malleable	Malleable
Material	steel	gage	iron	iron
Plate diameter	2.62"	2.62"	4.03"	4.03"
Bolt hole diameter	0.81"	0.81"	0.81"	0.94"
Plate thickness	0.172"	0.12"	0.20"	0.20"
Plate depth	0.42"	0.35"	0.62"	0.62"
Bolt hole diameter in timber members and metal side plates <sup>1</sup>	1 <sup>3</sup> / <sub>16</sub> "	1 <sup>3</sup> / <sub>16</sub> "	1 <sup>3</sup> / <sub>16</sub> "	15/16"
Washers, standard				
Round, cast or malleable iron, diameter	3"	3"	3"	3 <sup>1</sup> / <sub>2</sub> "
Round, wrought iron (minimum)				
Diameter	2"	2"	2"	2 <sup>1</sup> / <sub>4</sub> "
Thickness	5/32"	5/32"	5/32"	11/64"
Square plate				
Length of side	3"	3"	3"	3"
Thickness	1/4"	1/4"	1/4"	1/4"
Projected area: portion of one shear plate within member	× 645 for mm <sup>2</sup>			
	1.18 in. <sup>2</sup>	1.00 in. <sup>2</sup>	2.58 in. <sup>2</sup>	2.58 in. <sup>2</sup>

<sup>1</sup>Steel straps or shapes used as metal side plates shall be designed in accordance with accepted metal practices (see Section 2335.4.3).

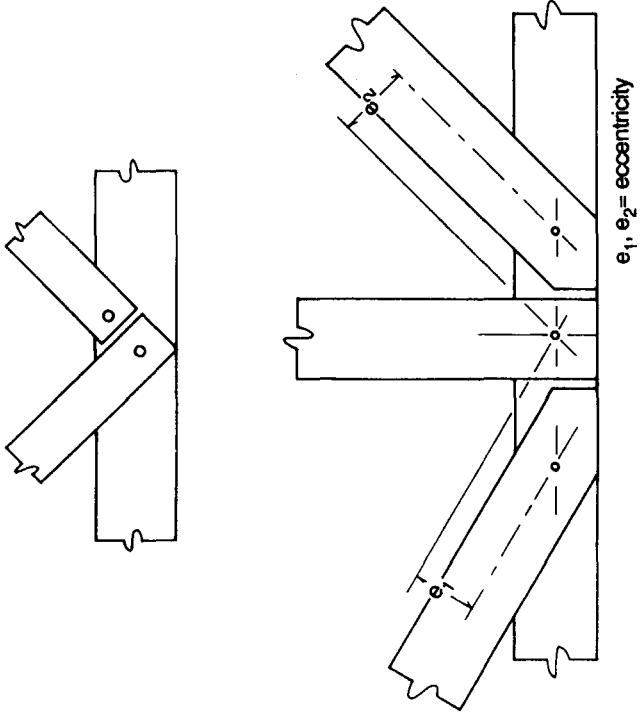
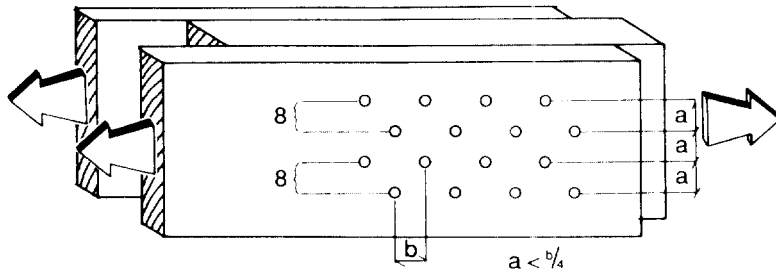
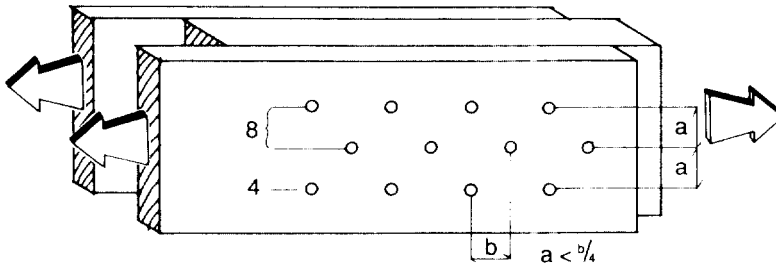

FIGURE 23-II-1—ECCENTRIC CONNECTIONS



Consider as 2 rows of 8 fasteners



Consider as 1 row of 8 fasteners and 1 row of 4 fasteners

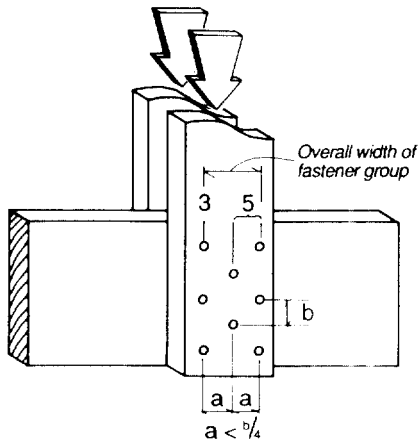

Consider as 1 row of 5 fasteners and 1 row of 3 fasteners

FIGURE 23-III-2—GROUP ACTION FOR STAGGERED FASTENERS

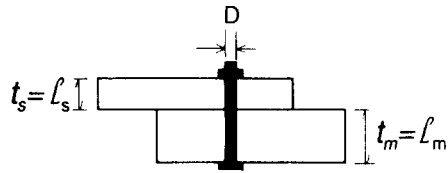
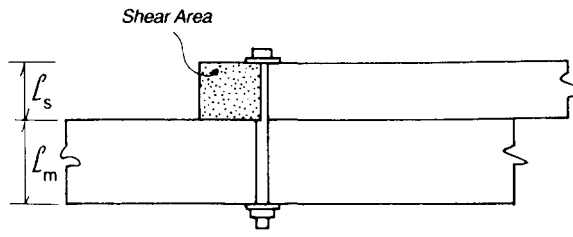
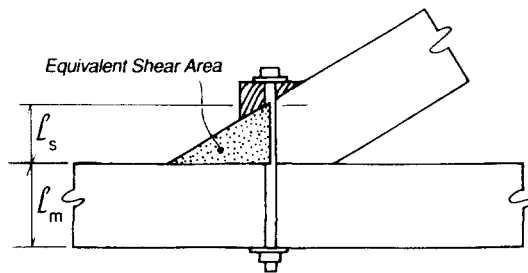

FIGURE 23-III-3—SINGLE SHEAR BOLTED CONNECTION



Parallel member connection



Angled member connection

FIGURE 23-III-4—SHEAR AREA FOR BOLTED CONNECTIONS

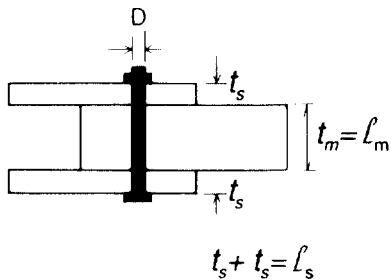

FIGURE 23-III-5—DOUBLE SHEAR BOLTED CONNECTION

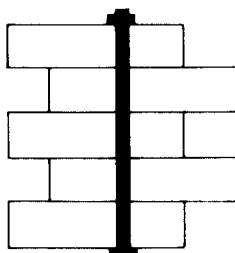

FIGURE 23-III-6—MULTIPLE SHEAR BOLTED CONNECTION

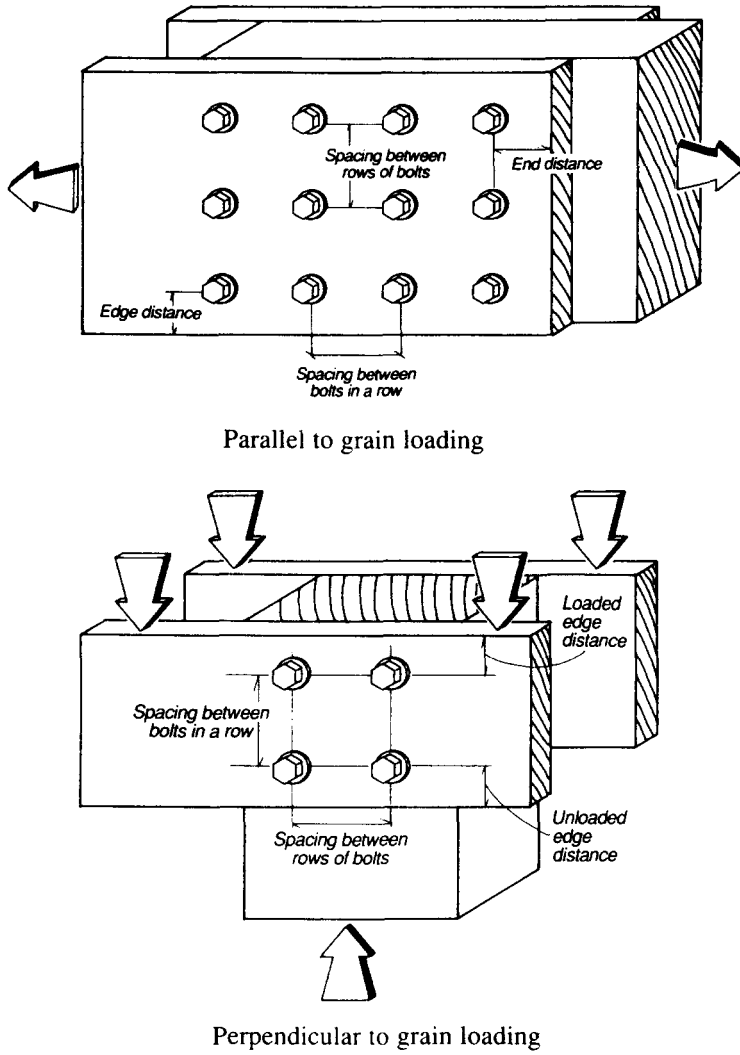

FIGURE 23-III-7—BOLTED CONNECTION GEOMETRY

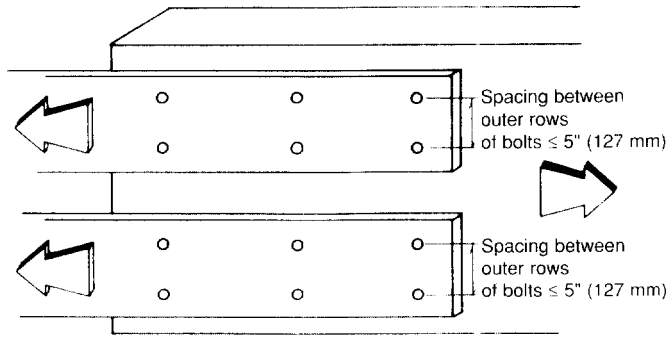

FIGURE 23-III-8—SPACING BETWEEN OUTER ROWS OF BOLTS

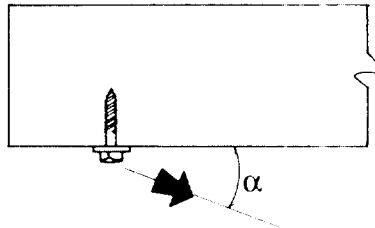

FIGURE 23-III-9—COMBINED LATERAL AND WITHDRAWAL LOADING



FIGURE 23-III-10—SPLIT RING CONNECTOR

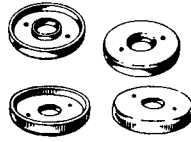
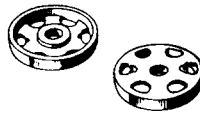

FIGURE 23-III-11—PRESSED STEEL SHEAR PLATE CONNECTOR



*Courtesy of TECO/Lumbertok*

FIGURE 23-III-12—MALLEABLE IRON SHEAR PLATE CONNECTOR

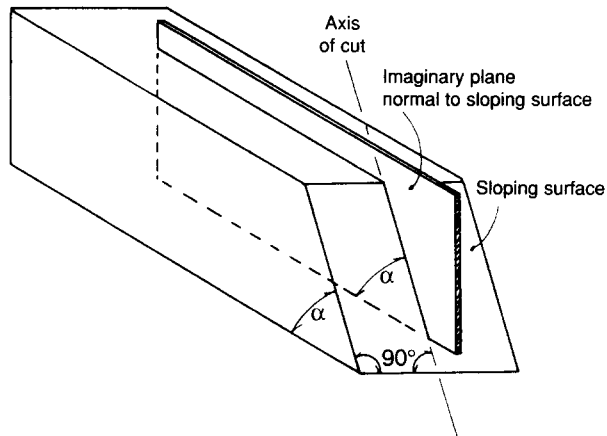

FIGURE 23-III-13—AXIS OF CUT FOR SYMMETRICAL SLOPING END CUT

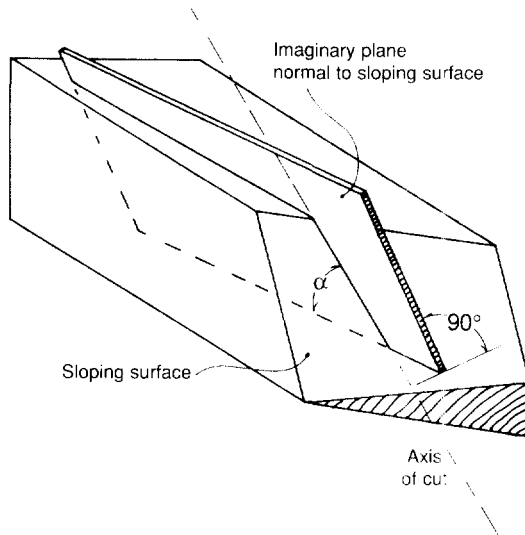

FIGURE 23-III-14—AXIS OF CUT FOR ASYMMETRICAL SLOPING END CUT

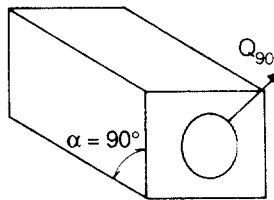

FIGURE 23-III-15—SQUARE END CUT

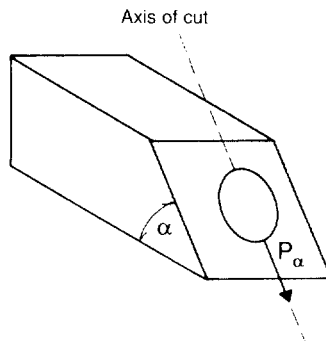

FIGURE 23-III-16—SLOPING END CUT WITH LOAD PARALLEL TO AXIS OF CUT ( $\phi = 0^\circ$ )

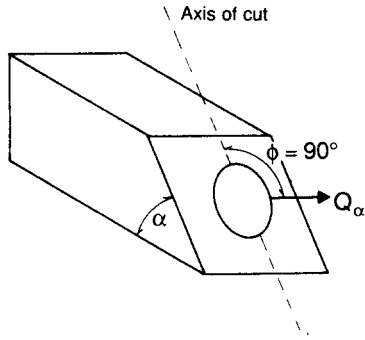

FIGURE 23-III-17—SLOPING END CUT WITH LOAD PERPENDICULAR TO AXIS OF CUT ( $\phi = 90^\circ$ )

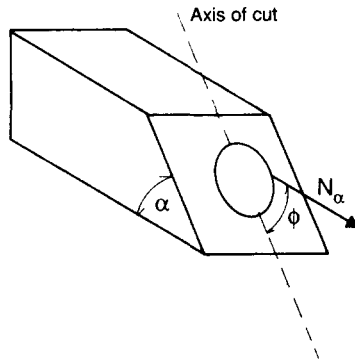
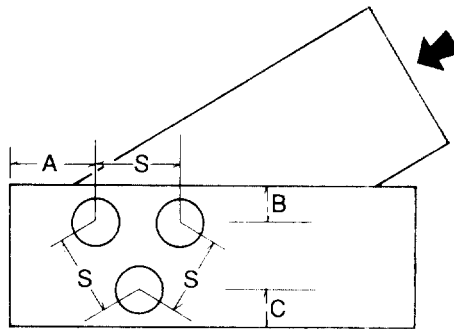
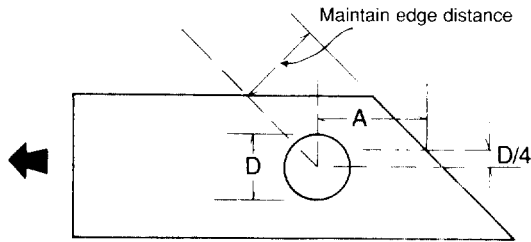

FIGURE 23-III-18—SLOPING END CUT WITH LOAD AT AN ANGLE  $\phi$  TO AXIS OF CUT



A = end distance  
 B = unloaded edge distance  
 C = loaded edge distance  
 S = spacing

FIGURE 23-III-19—CONNECTION GEOMETRY FOR SPLIT RINGS AND SHEAR PLATES



A = end distance  
 D = connector diameter

FIGURE 23-III-20—END DISTANCE FOR MEMBERS WITH SLOPING END CUT

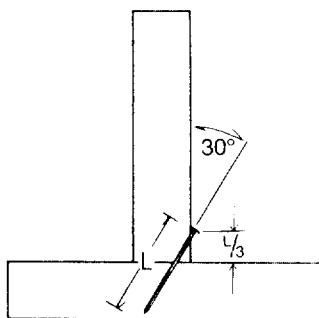
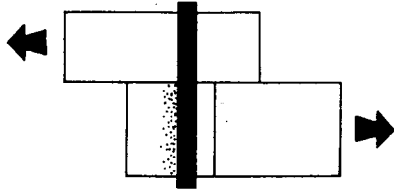

FIGURE 23-III-21—TOENAIL CONNECTION

Single Shear Connections



Mode  $I_m$

Modes  $I_m$  and  $I_s$  represent bearing-dominated yield of the wood fibers in contact with the fastener in either the main or side member(s), respectively.

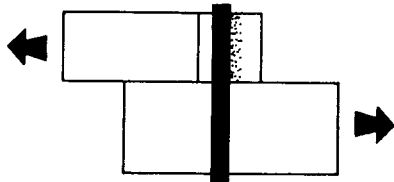

Mode  $I_s$

Double Shear Connections

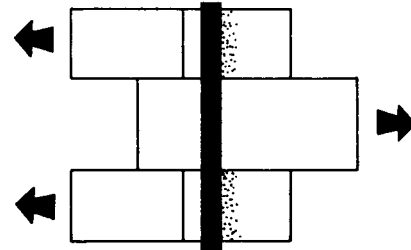
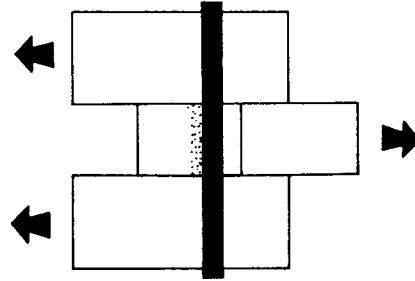
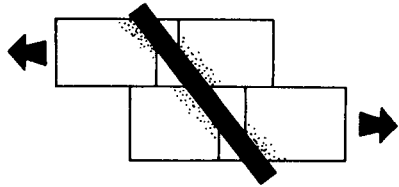
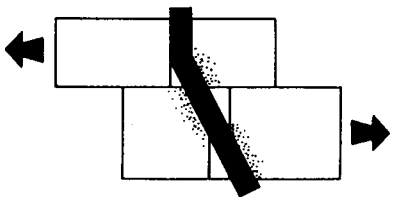

FIGURE 23-III-22—CONNECTION YIELD MODES



**Mode II**

(Not applicable)  
 Mode II represents pivoting of the fastener at the shear plane of a single shear connection with limited localized crushing of wood fibers near the faces of the wood member(s), as may occur in bolted connections with oversize bolt holes. Mode II does not occur in single shear nail or screw connections with minimum required fastener penetration.



**Mode III<sub>m</sub>**

(Not applicable)  
 Modes III<sub>m</sub> and III<sub>s</sub> represent fastener yield in bending at one plastic hinge point per shear plane, and bearing-dominated yield of wood fibers in contact with the fastener in either the main or side member(s), respectively.

FIGURE 23-III-22—CONNECTION YIELD MODES—(Continued)

Single Shear Connections

Double Shear Connections

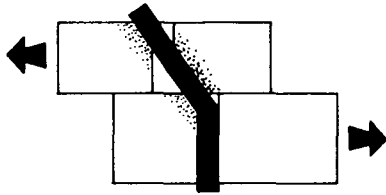

Mode III<sub>s</sub>

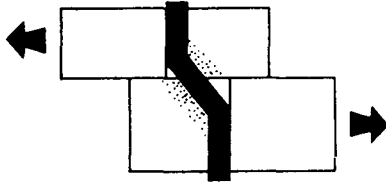
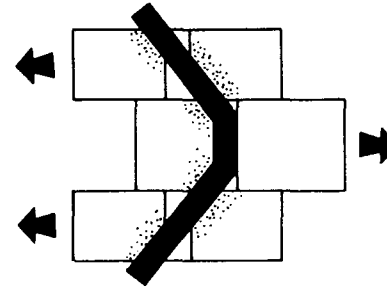

Mode IV

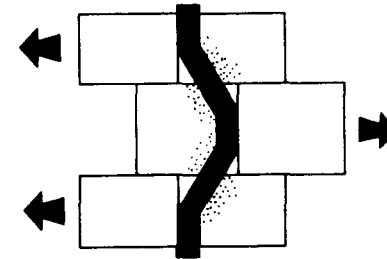

Mode IV represents fastener yield in bending at two plastic hinge points per shear plane, with limited localized crushing of wood fibers near the shear plane(s).

FIGURE 23-III-22—CONNECTION YIELD MODES—(Continued)

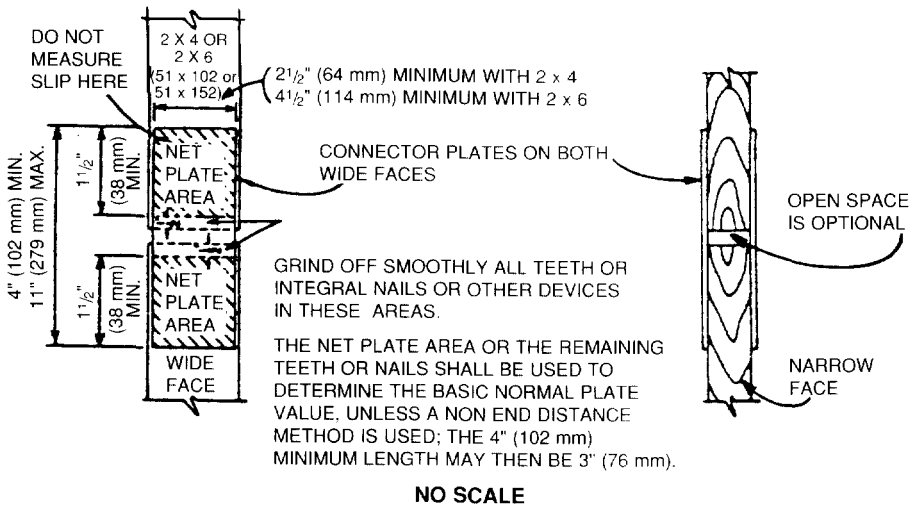
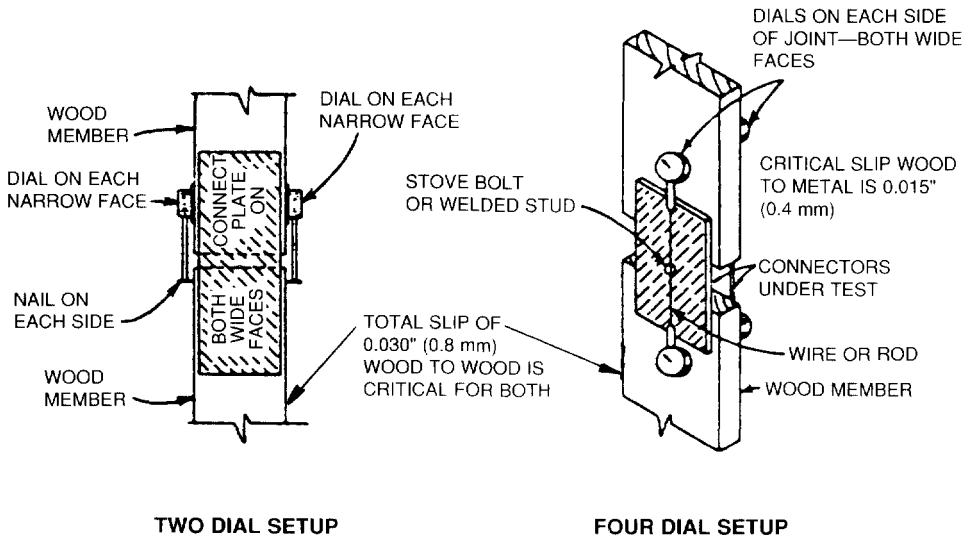

**STANDARD CONNECTOR EVALUATION TENSION TEST**

**FIGURE 23-III-23**

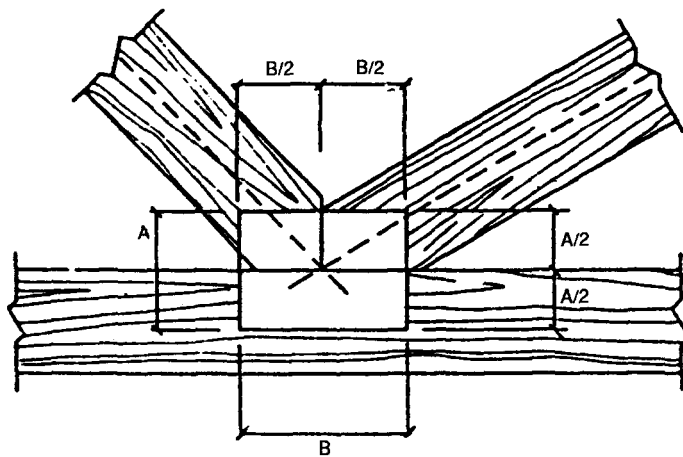

FIGURE 23-III-24—SYMMETRICAL POSITIONING

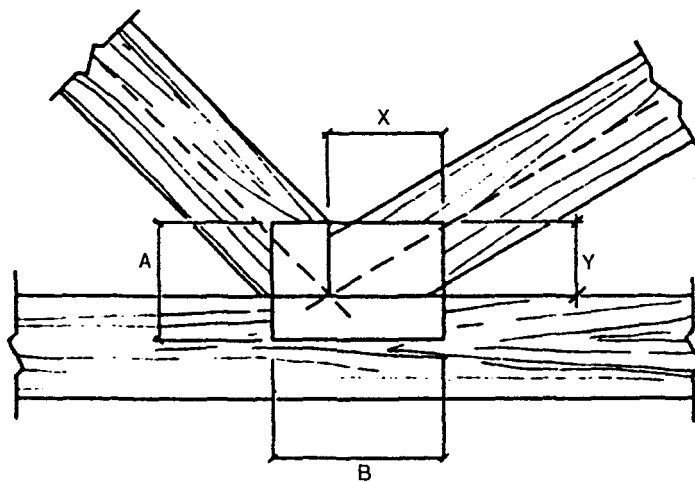
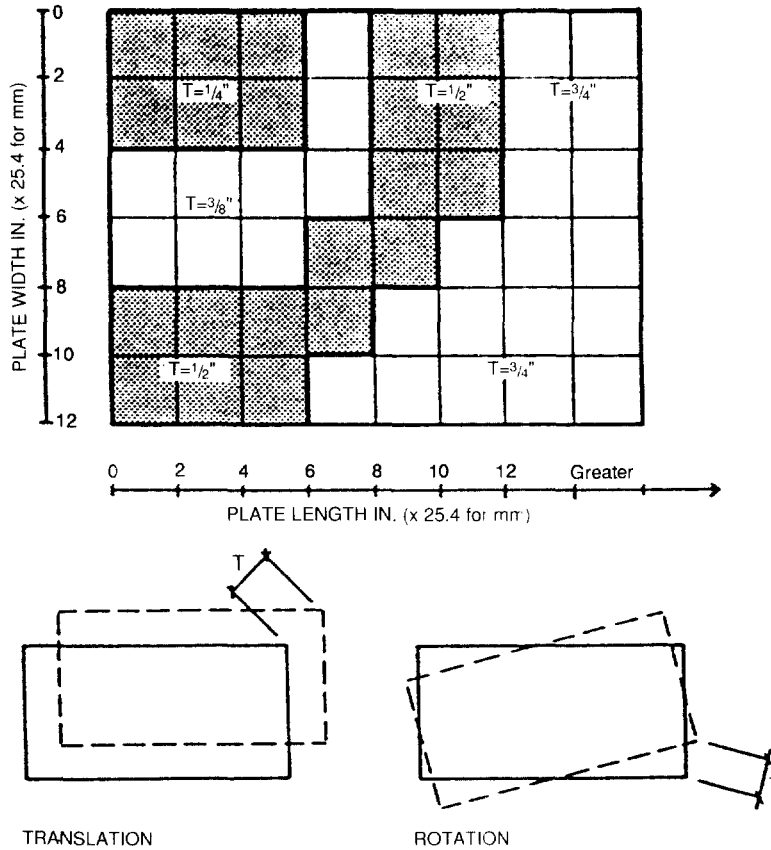

FIGURE 23-III-25—NONSYMMETRICAL POSITIONING



Note: The tolerance in plate location from that specified on the truss drawing shall be limited, such that no point on the plate is displaced from its design location more than indicated in the above table for the given plate size. Where plate size falls on the line, use the lesser tolerance. For example: 4 x 6 (102 x 152 mm) plate tolerance is 1/4" (6.4 mm), 8 x 12 (203 x 305 mm) plate tolerance is 3/4" (19 mm).

For non symmetrical plate positioning use the dimension of the smallest contact area per member as the plate dimension for the plate location tolerance that shall govern.

FIGURE 23-III-26—METAL CONNECTOR PLATE LOCATION TOLERANCE (T)

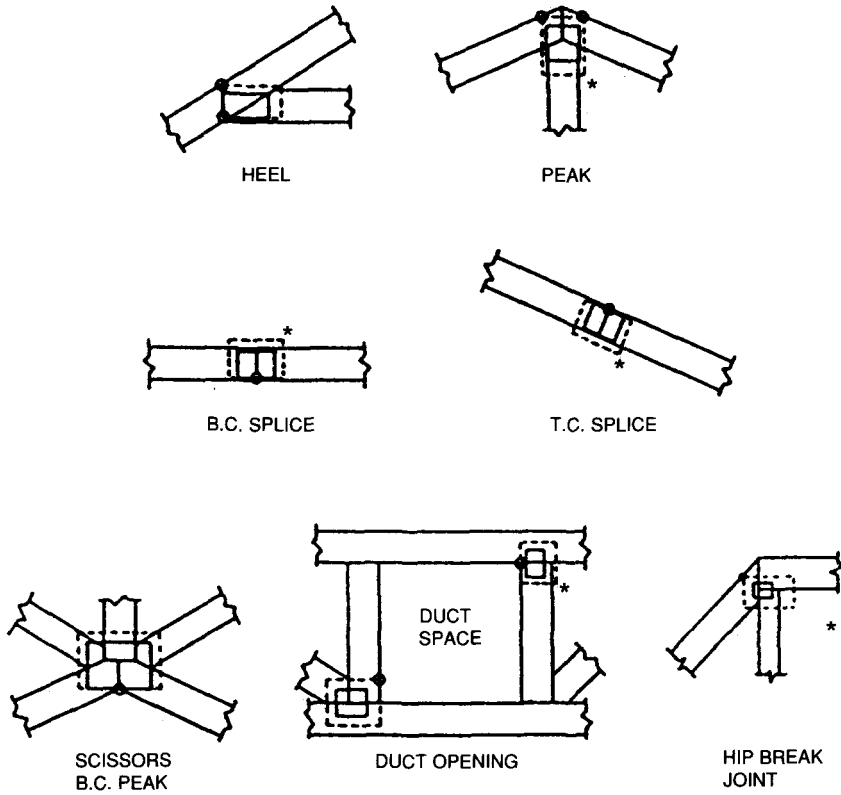

⊙ —Indicates control point beyond which plate shall not extend.

\* —Indicates extension of plate which shall be checked for interference before substitution of larger plate.

**FIGURE 23-III-27—EXAMPLES OF SUBSTITUTION OF LARGER METAL CONNECTOR PLATES THAN SPECIFIED SIZE**

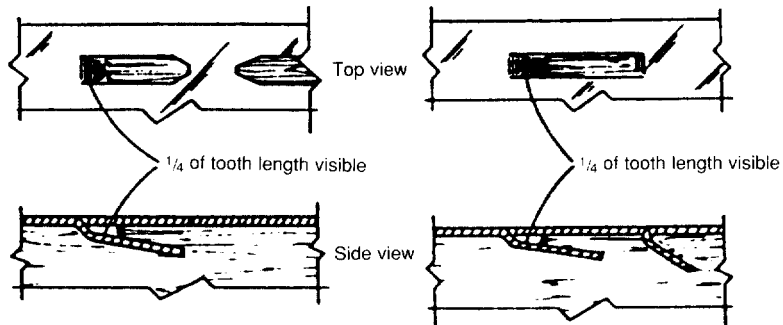
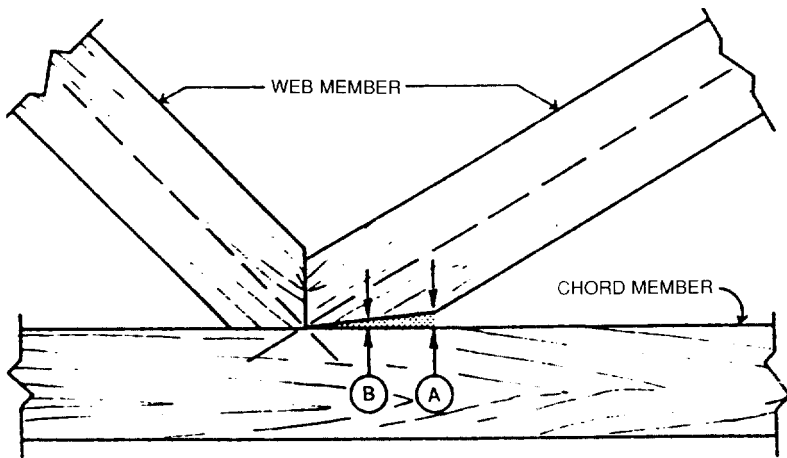
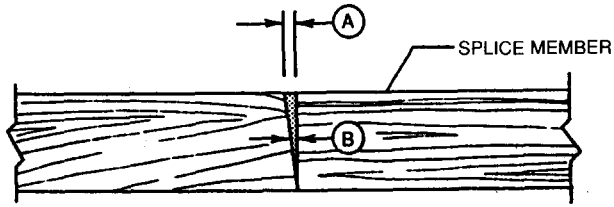

FIGURE 23-III-28—VISIBLE EVIDENCE OF FLATTENING OF METAL CONNECTOR PLATE TEETH



A—MAXIMUM GAP	$\frac{1}{4}$ inch (6.4 mm)
B—AVERAGE GAP	$\frac{1}{8}$ inch (3.2 mm)

FIGURE 23-III-29—INTERIOR JOINT TOLERANCES



	TENSION	COMPRESSION
A—MAXIMUM GAP	$\frac{1}{8}$ inch (3.2 mm)	$\frac{1}{16}$ inch (1.6 mm)
B—AVERAGE GAP	$\frac{1}{16}$ inch (1.6 mm)	$\frac{1}{32}$ inch (0.8 mm)

Note: Compression splice joints not meeting these joint tolerances shall be shimmed with metal shims or alternatives acceptable to the truss design engineer.

FIGURE 23-III-30—SPLICE JOINT TOLERANCES

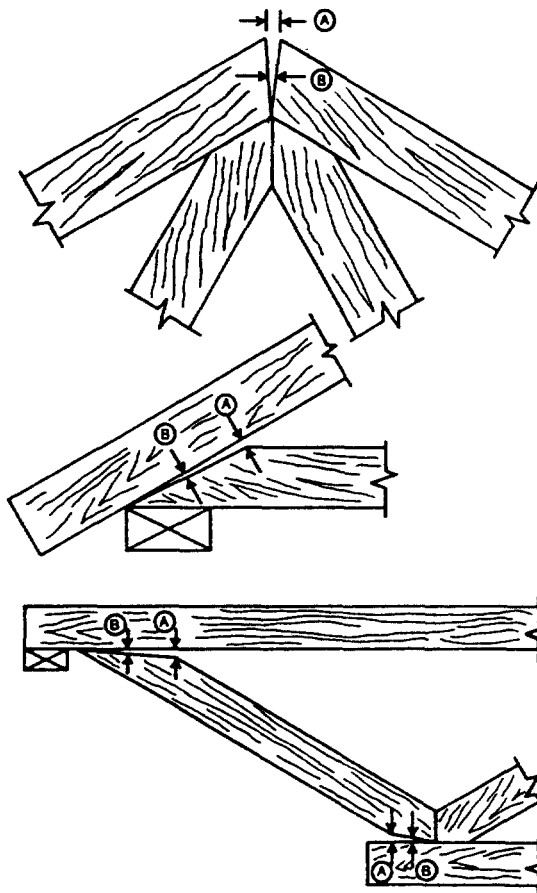

A—MAXIMUM GAP	$\frac{1}{8}$ inch (3.2 mm)
B—AVERAGE GAP	$\frac{1}{16}$ inch (1.6 mm)

FIGURE 23-III-31—EXTERIOR JOINT TOLERANCES

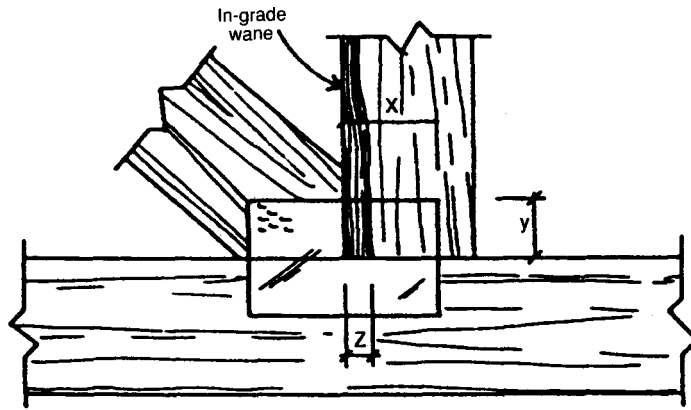

Note: If  $xy =$  required area, then  $zy \leq 0.1 xy$ .

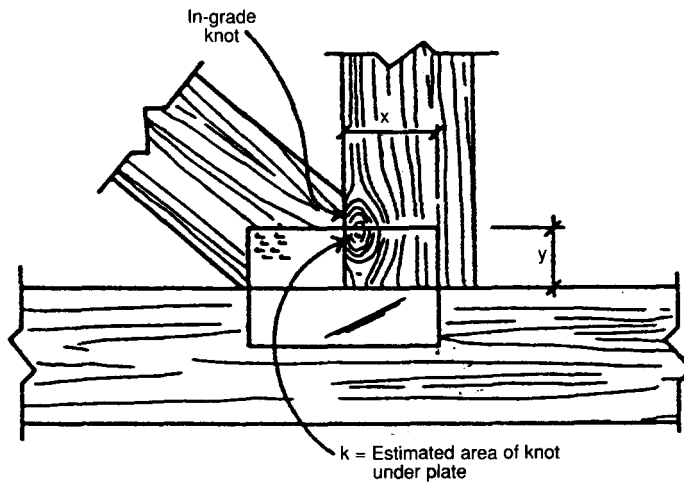

$k =$  Estimated area of knot under plate

Note: If  $xy =$  required area, then  $k \leq 0.1 xy$ .

**FIGURE 23-III-32—WANE AND KNOTS IN METAL CONNECTOR PLATE AREA**

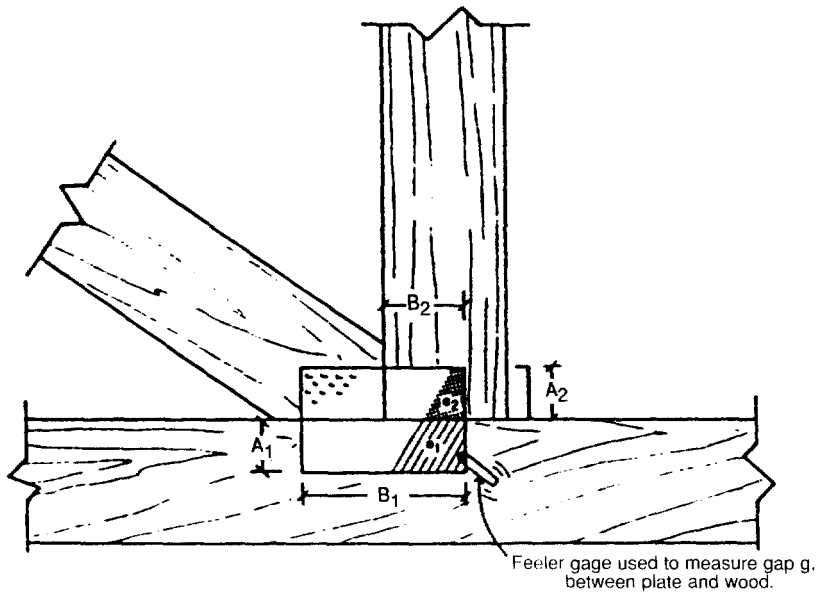

Note:  $a_n$  is the estimated area of plate, per member contact area ( $A_n B_n$ ), where  $G \leq 0$ ;  $1/$  or  $1/16$ " (1.6 mm) (whichever is greater), then  $a_n \leq 1/3$  minimum required contact area where  $n$  is the web or chord member being evaluated.

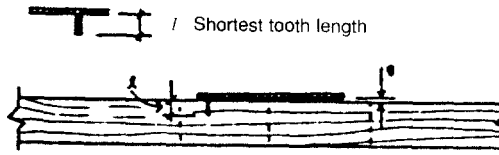

Note: If  $a$  = estimated area of plate where  $g \leq 0.17$  or  $1/16$ " (1.6 mm) (whichever is greater), then  $a_n \leq 1/3$  minimum required contact area

FIGURE 23-III-33—METAL CONNECTOR PLATE EMBEDMENT TOLERANCES

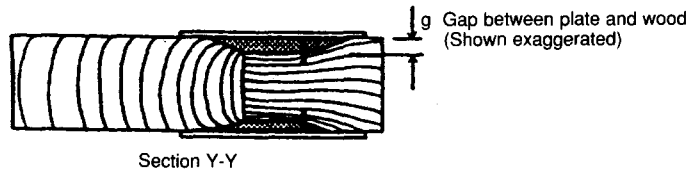
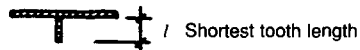
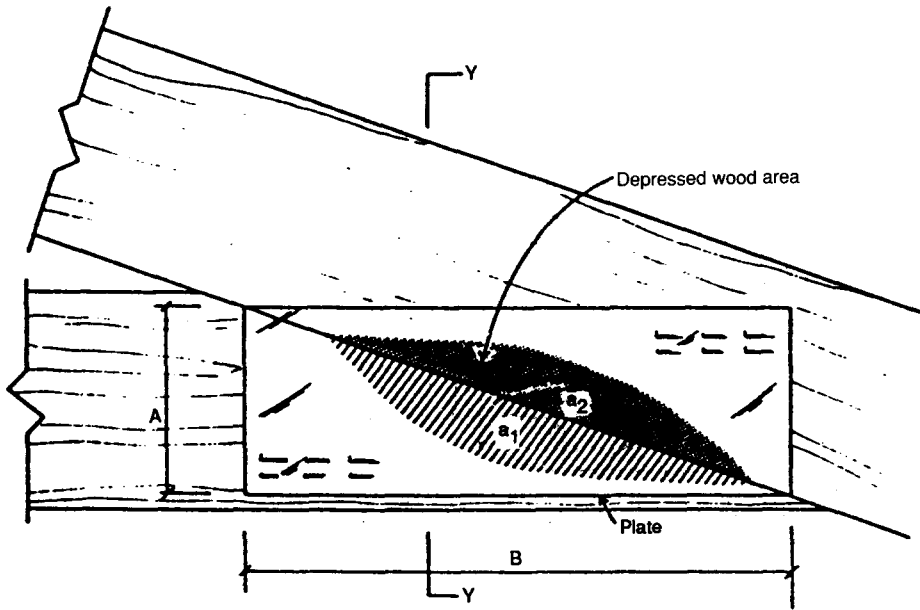

Note: If  $a_n$  is the estimated area of plate, per member contact area, where  $g \leq 0.1$  or  $1/16"$  (1.6 mm) (whichever is greater), then,  $a_n \leq 1/3$  minimum required plate contact area.

FIGURE 23-III-34—METAL CONNECTOR PLATE EMBEDMENT TOLERANCES

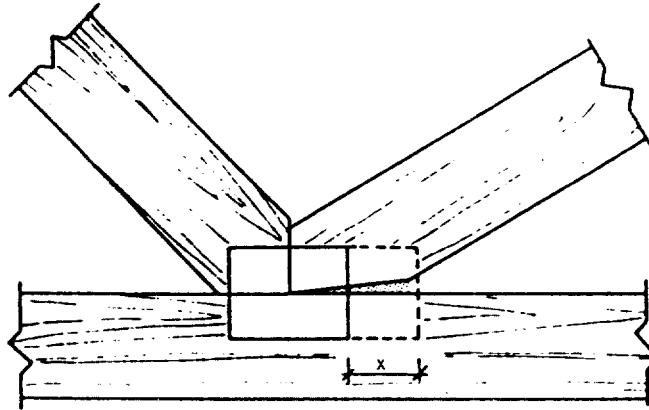

Note: Add plate length X, to cover entire gap (both faces)

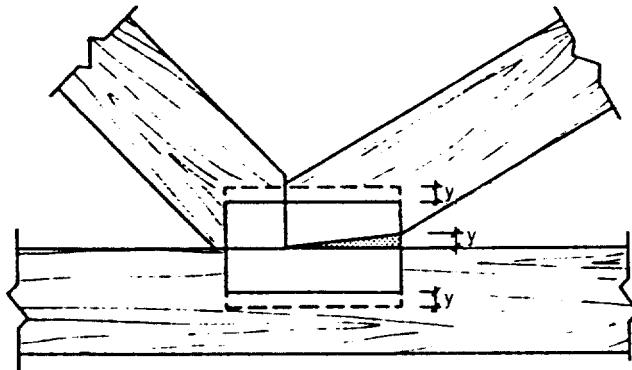

Note: Add plate width Y, equal to max. gap both sides of plate (both faces).

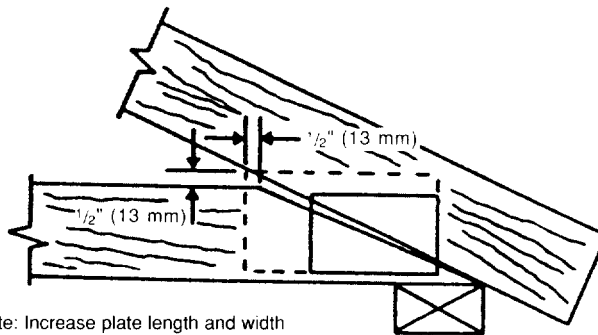

Note: Increase plate length and width  $\frac{1}{2}$ " (13 mm) past scarf cut (both faces).

FIGURE 23-III-34—METAL CONNECTOR PLATE EMBEDMENT TOLERANCES—(Continued)

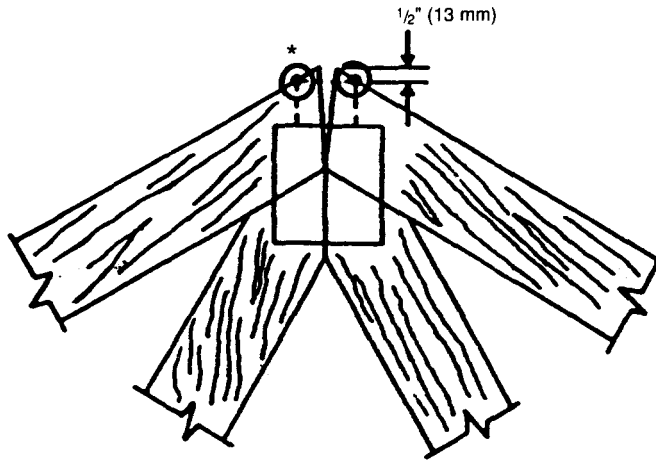

Note: Add additional plate to within  
1/2" (13 mm) of peak (both faces).

\* —Indicates extension of plate which shall be  
checked for interference before substitution  
of larger plate.

**FIGURE 23-III-35—CORRECTION OF JOINT TOLERANCE**

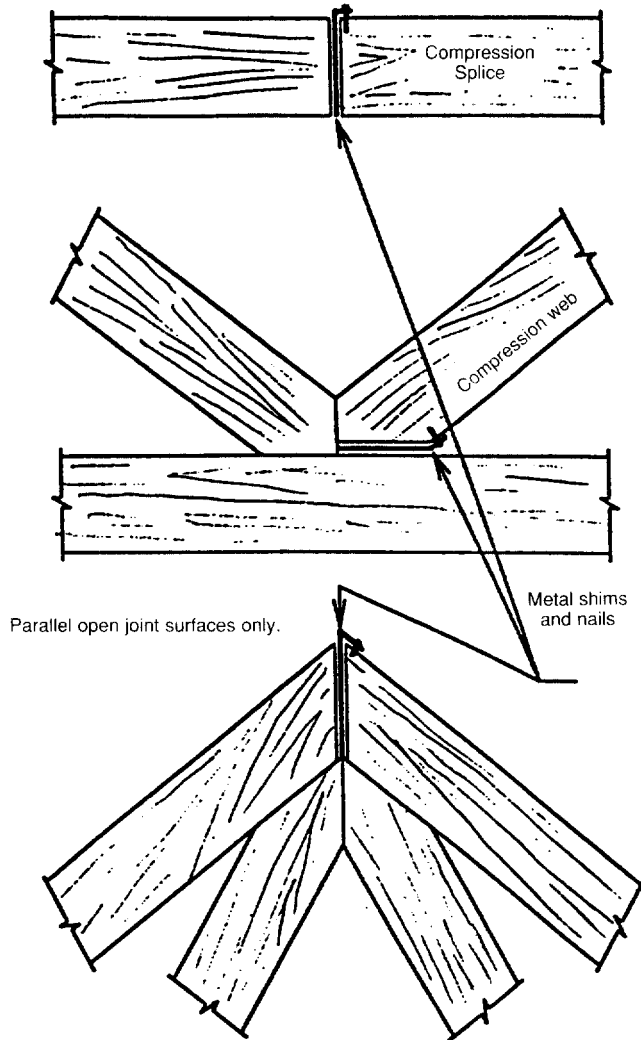

Note: Shims are driven to tight contact after connector plates are in place.

FIGURE 23-III-36—COMPRESSION JOINT REPAIR

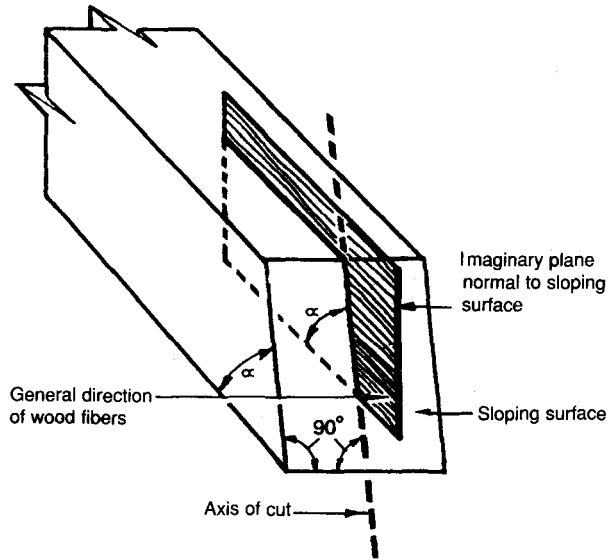

**FIGURE 23-III-37**  
**Axis of cut for symmetrical sloping end; cut at angle  $\alpha$**

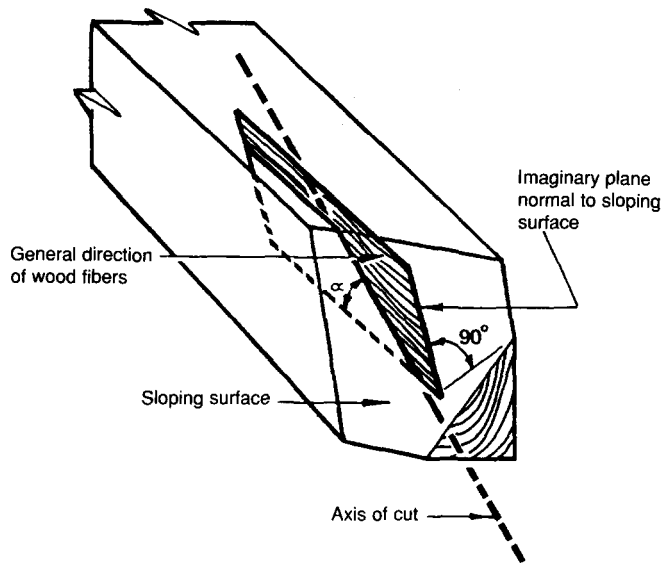

**FIGURE 23-III-38**  
**Axis of cut for asymmetrical compound sloped end cut.**

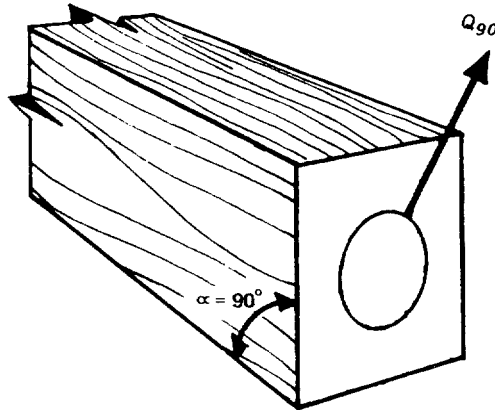

FIGURE 23-III-39  
Square-cut end,  $\alpha = 90$  degrees

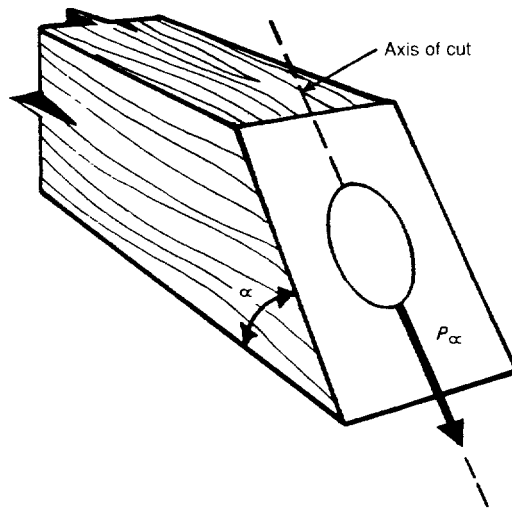

FIGURE 23-III-40  
Load parallel to axis of cut;  $\phi = 0$  degrees

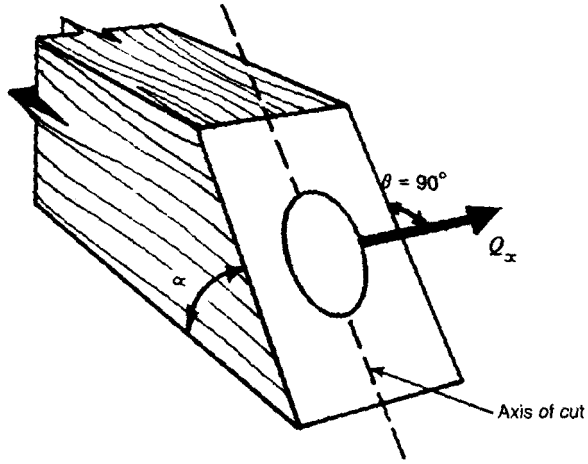
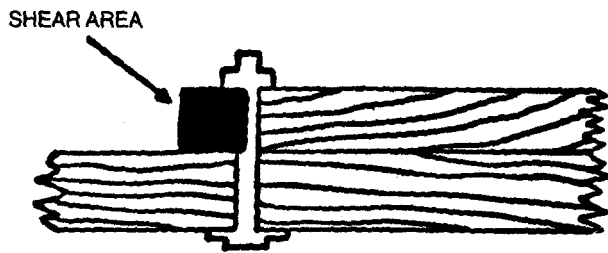
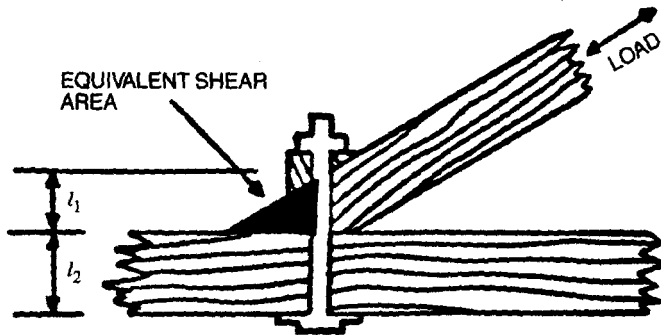

FIGURE 23-III-41  
Load perpendicular to axis of cut;  $\theta = 90$  degrees



(A) PARALLEL MEMBER JOINT



(B) ANGLED MEMBER JOINT

FIGURE 23-III-42

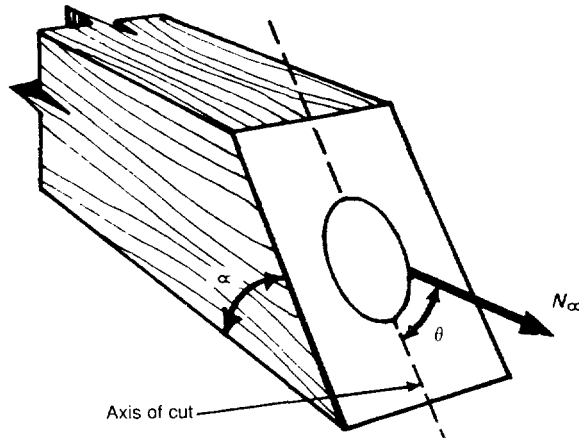

**FIGURE 23-III-43**  
**Load at angle  $\theta$  to axis of cut.**

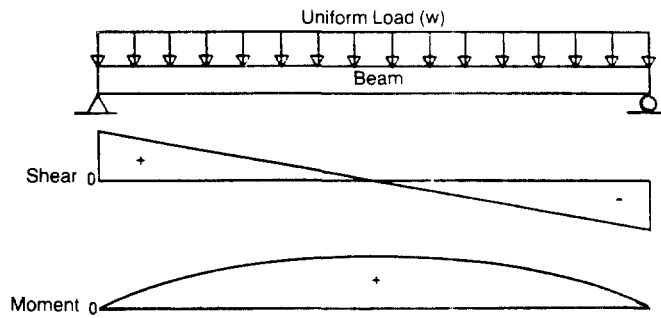

**FIGURE 23-III-44—SIGN CONVENTION FOR EQUIVALENT BEAM**

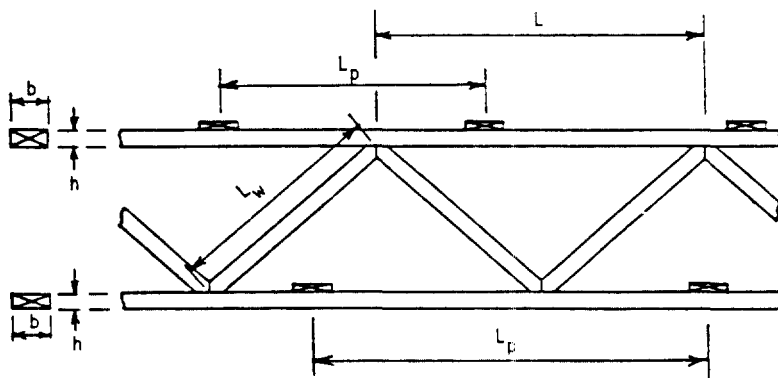

**FIGURE 23-III-45—DIMENSIONS USED TO DETERMINE  $L/d$**

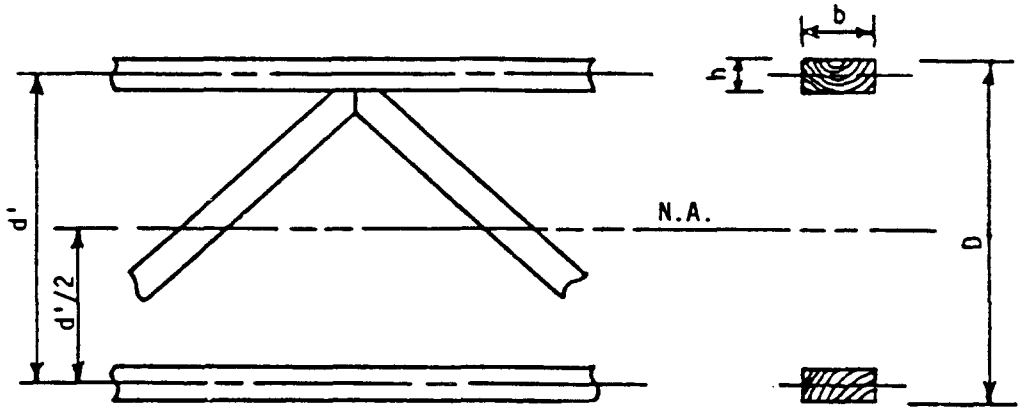

FIGURE 23-III-46—DIMENSIONS USED TO DETERMINE  $l_b$

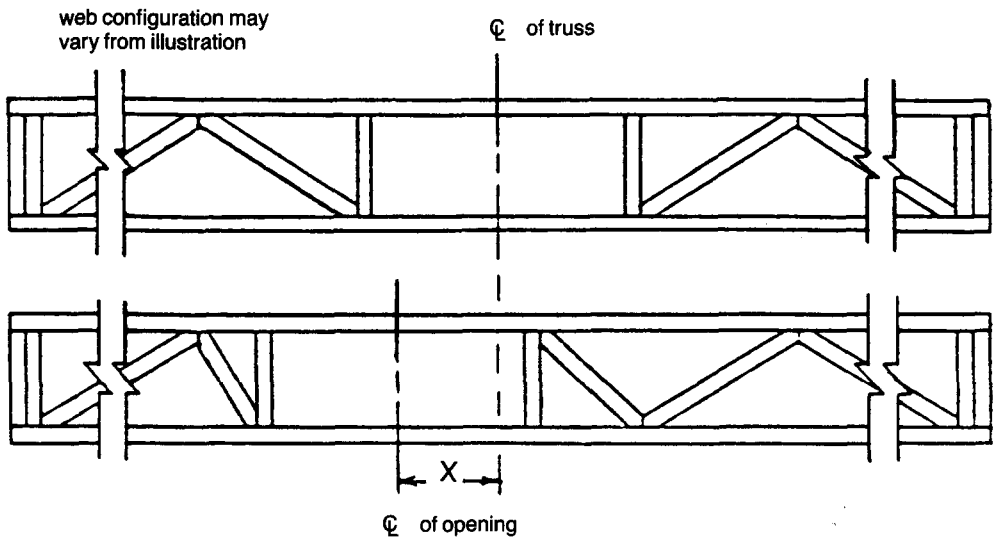

FIGURE 23-III-47—MEASUREMENT OF OPENING OFFSET

**Division IV—DESIGN STANDARD FOR STRUCTURAL GLUED BUILT-UP  
MEMBERS—PLYWOOD COMPONENTS**

**Based on Design and Fabrication Specifications of  
the American Plywood Association**

**SECTION 2344 — PLYWOOD STRESSED SKIN PANELS**

**2344.1 Scope.** This standard covers requirements for the design of plywood stressed skin panels as referred to in Section 2313.

**2344.2 Definition.** A panel with stressed covers, or a stressed skin panel, is one in which the covering acts integrally with the framing members to resist bending loads in proportion to its effective moment of inertia. It consists of several longitudinal framing members or ribs spaced by headers and covered on top alone or top and bottom with plywood panels.

**2344.3 Design.**

**2344.3.1 Spacing of ribs.** The clear distance between ribs shall not exceed twice the basic spacing set forth in Table 23-IV-A.

**2344.3.2 Skin bending.** The stressed skin shall be capable of resisting bending stresses due to loads normal to the skin with allowance for direction of the face grain.

**2344.3.3 Determination of section properties.** For determination of bending stresses, the section properties shall be calculated considering that only the ribs or plies of the ribs and the plies in the stressed skin with grain parallel to the span of the ribs are effective. If the clear distance between ribs is less than the basic spacing "*b*" as set forth in Table 23-IV-A, the effective width of the skin is equal to the full panel width. If the clear distance between ribs is greater than the basic spacing "*b*," the effective width of the skins equals the sum of the widths of the ribs in contact with the stressed skin plus a portion of the skin extending a distance equal to 0.5 "*b*" each side of each rib.

For determination of horizontal shear, rolling shear, deflection and splice stresses, the section properties shall be based on the gross section of all material having its grain parallel with the direction of the principal stress. The modulus of elasticity used to calculate deflection shall be based on the modulus of elasticity of the plywood stressed skins.

**2344.3.4 Method of design.** Stressed skin panels shall be designed in accordance with accepted engineering formulas, without exceeding the allowable stresses specified in Section 2344.4.

**2344.3.5 Splices.** The stressed skin panels and ribs shall be continuous in the longitudinal direction, except where adequately spliced and designed in accordance with Section 2344.4.

**2344.4 Allowable Stresses.**

**2344.4.1 Panel stresses.**

**2344.4.1.1 Direct stress from bending.** The allowable working stresses in the stressed skin flanges shall not exceed the values set forth in Table 23-I-B for tension or compression when multiplied by the factor "*F*":

*b* = the clear distance between ribs in inches (mm).

"*b*" = the basic spacing shown in Table 23-IV-A in inches (mm).

For *b*/*b*" equal or less than 0.5, *F* equals 1.

For *b*/*b*" greater than 0.5 and less than 1.0

$$F = 0.67 (2 - b/ "b").$$

For *b*/*b*" equal or greater than 1.0 and not greater than 2.0

$$F = 0.67.$$

**2344.4.1.2 Rolling shear.** The shear between interior ribs and plywood skin shall not exceed the values set forth in Table 23-I-B for rolling shear. The allowable working stresses shall be reduced 50 percent at exterior ribs. This reduction applies to exterior stringers whose clear distance to the panel edge is less than half the clear distance between stringers.

**2344.4.1.3 Stress in plywood skin splices.**

**2344.4.1.3.1 Scarf-jointed splice in compression.** The allowable stress in the skin at the splice shall not exceed the values specified in Section 2344.4.1.1. The slope of the scarf shall not be steeper than 1 in 5.

**2344.4.1.3.2 Butt-jointed splice in compression.** Where a splice plate is installed on one side of the joint, the allowable stress in the skin at the splice shall not exceed the values specified in Section 2344.4.1.1, provided said values are reduced in proportion to the ratio of the width of the splice plate to the width of the stressed skin. The splice plate shall be at least equal in thickness and grade to the skin being spliced. The splice plate shall be centered over the joint with the face grain parallel to the face grain of the skin. The minimum length of the splice plate, measured parallel to the span, shall not be less than the values set forth in Table 23-IV-B. Splice plates shall be preglued to the skins prior to assembly of the panel. No percentage reduction is taken for compressive stress.

**2344.4.1.3.3 Scarf-jointed splice in tension.** The allowable stress in the skin at the splice shall not exceed the values specified in Section 2344.4.1.1. The slope of scarf shall not be steeper than 1 in 8.

**2344.4.1.3.4 Butt-jointed splice in tension.** Where a splice plate is installed, the allowable stress in the skin at the splice shall not exceed the values set forth in Table 23-IV-C. The splice plate thickness, position, orientation to face grain, installation and length shall conform to Section 2344.4.1.3.2.

**2344.4.2 Rib or longitudinal stresses.**

**2344.4.2.1 Bending.** Bending stresses shall not exceed the values set forth in Table 23-I-A-1, 23-I-A-2, 23-I-A-3, 23-I-A-4, 23-I-A-5 or 23-I-A-6.

**2344.4.2.2 Horizontal shear.** Horizontal shear shall not exceed the values set forth in Table 23-I-A-1, 23-I-A-2, 23-I-A-3, 23-I-A-4, 23-I-A-5 or 23-I-A-6.

**2344.4.2.3 Splices in ribs or longitudinal members.** Accurately fitted and well-glued scarf or finger joints are permitted provided the maximum stress in bending does not exceed the percentages of the basic flexural stress shown in ANSI/AITC A190.1 and ASTM D 3737. In the finger joint, the portion of the joint occupied by the tips of the fingers at that cross section shall not be considered as effective. Finger joints and other nonstandard configurations of scarf joints may be prequalified in accordance with ANSI/AITC A190.1 and ASTM D 3737. The effective slope of the joint shall also be determined.

**2344.5 Fabrication.** The plywood stressed skins shall be fabricated in accordance with the procedures specified in Section 2348.

**SECTION 2345 — PLYWOOD CURVED PANELS**

**2345.1 Scope.** This division covers requirements for the design of plywood curved panels as referred to in Section 2313. Fabrication procedure shall be in accordance with the requirements of Section 2348.

**2345.2 General Design.** Curved panels may be designed as either curved flexural panels or arch panels. The curved flexural panels act as a simple beam, without developing horizontal thrust. Bearing details are designed accordingly, with provision for horizontal deflection. Tie rods are not required. Arch panels are stressed both in compression and in flexure. They exert horizontal thrust at the supports and therefore require tie rods or abutments.

**2345.3 Definition.**

**2345.3.1 Core types.** Curved plywood panels consist of full-length plywood faces top and bottom spaced by and joined with glue to a structural core capable of resisting the shearing forces. The core may consist of one or more layers of plywood, butt-jointed or full-length, glued over the full areas to the faces or spaced ribs constructed of single-piece or laminated plywood or lumber strips, spaced as required, either preglued or glued during panel assembly.

**2345.4 Allowable Stresses.**

**2345.4.1 Plywood core.** The allowable working stresses in plywood core type of construction in flexure, compression and tension shall not exceed the values set forth in Table 23-I-B and reduced for curvature by multiplication by the following curvature factor:

$$1 - 2000 \left[ \frac{t}{R} \right]^2$$

**WHERE:**

- $R$  = radius of curvature at center line of member, inches (mm).
- $t$  = thickness, out-to-out of plies parallel with the stress, inches (mm).
- $\frac{t}{R}$  = shall not exceed 1/125.

**2345.4.2 Spaced ribs.** The allowable working stresses in compression and tension shall be established as specified in Section 2345.4.1. In addition, the allowable stresses shall be further reduced as for stressed skin panels as specified in Section 2344.

**2345.4.3 Radial stresses.** The radial stresses induced by bending moment in a curved spaced rib or plywood core panel shall be computed by the formula:

$$S_R = \frac{3M}{2Rbh}$$

**WHERE:**

- $b$  = width of stringer, inches (mm).
- $h$  = overall height of panel, inches (mm).
- $M$  = bending moment, in inch-pounds (N·mm), on a width of panel equal to the rib spacing.
- $R$  = radius of curvature at center line of member, inches (mm).
- $S_R$  = actual stress in a radial direction, pounds per square inch (N/mm<sup>2</sup>).

When  $M$  is in the direction tending to decrease curvature (increase the radius) the stress is in tension and  $S_R$  for plywood shall be limited to one half the values shown for rolling shear in the plane of the plies in Table 23-I-B.  $S_R$  for lumber ribs shall be limited to one third the values shown for horizontal shear in Tables 23-I-A-1, 23-I-A-2, 23-I-A-4 and 23-I-A-5. When  $M$  is in the direction tending to increase curvature (decrease the radius) the stress is in compression and  $S_R$  for plywood shall be limited to the values shown for compression perpendicular to the grain in Table 23-I-B.  $S_R$  for lumber ribs shall be limited to the values shown for compression perpendicular to the grain in Table 23-I-A-1, 23-I-A-2, 23-I-A-3, 23-I-A-4, 23-I-A-5 or 23-I-A-6.

**2345.5 Effective Cross Section.**

**2345.5.1 Direction of grain.** All plywood and lumber having its grain parallel with the direction of stress shall be considered effective in resisting the stress, except for spaced-rib panels which should be as outlined in Section 2344.

**2345.5.2 Scarfed plywood joints.** The slope of scarfed joints shall not be steeper than one in eight in order to fully develop the strength of the plywood elements.

**2345.5.3 Glued-plywood butt joints with splice plates.** Butt joints with splice plates shall be designed in accordance with Part I of this standard. Splice plates shall be preglued to the skins prior to assembly of the panel.

**2345.5.4 Butt joints without splice plates.** The effective strength of solid plywood core panels and of laminated ribs in a spaced rib panel at a section containing a butt joint in any lamination shall be determined by ignoring the butted lamination and any other lamination containing a butt joint closer than 50 times the lamination thickness.

**2345.5.5 Deflection.** The deflection of curved panels containing butt joints in either the core or the faces may be based on the gross section of all material having its grain parallel with the direction of principal stress, provided all butt joints are staggered at least 10 times the lamination thickness.

**2345.6 Design of Curved Flexural Panels.** Curved flexural panels shall be designed as simple beams in accordance with the applicable parts of this standard, with provisions to permit horizontal displacement at supports. The extent of this displacement shall be determined in accordance with accepted engineering practice.

**2345.7 Design of Arch Panels.**

**2345.7.1 General.** Arch panels shall be designed in accordance with this standard as arches which are subjected to combined bending and direct stress. Determination of vertical and horizontal reactions and maximum axial loads, moments and shears shall be based on accepted engineering practice.

**2345.7.2 Bending and direct stress.** Combined bending and direct stress shall be calculated by the formula:

$$\frac{P}{Ac} + \frac{M}{Sf} = 1$$
$$c = \frac{0.3E}{(l/d)^2}$$

**WHERE:**

- $A$  = area in square inches ( $\text{mm}^2$ ) of arch cross section per foot (mm) width of arch, of plies with their grain parallel to the direction of the stress.
- $c$  = allowable unit compressive stress in pounds per square inch ( $\text{N}/\text{mm}^2$ ), as indicated by the above formula but not to exceed the values in Tables 23-I-A-1, 23-I-A-2, 23-I-A-3, 23-I-A-4, 23-I-A-5 and 23-I-A-6.
- $d$  = thickness, out-to-out, of plies with their grain parallel to the direction of the stress in inches (mm).
- $E$  = modulus of elasticity of skins in pounds per square inch ( $\text{N}/\text{mm}^2$ ).
- $f$  = allowable stress in extreme fiber, pounds per square inch ( $\text{N}/\text{mm}^2$ ), tension or compression, modified by Sections 2344.4.1 and 2345.4.1 as applicable.
- $l$  = chord length in inches (mm) between points of zero moment.
- $M$  = moment, in inch-pounds per foot ( $\text{N}\cdot\text{mm}/\text{mm}$ ) width of arch.
- $P$  = direct force, pounds per foot ( $\text{N}/\text{mm}$ ) width of arch.
- $S$  = section modulus, inches cubed per foot ( $\text{mm}^3/\text{mm}$ ) width of arch, of plies with their grain parallel to the direction of the stress.

**2345.7.3 Shear stresses.** Shear stresses shall be calculated by the following formula:

$$S = \frac{VQ}{Ib}$$

**WHERE:**

- $b$  = width of rib, inches (mm).

[ $b$  = 12 inches (305 mm) for solid plywood core panel.]

$I$  = moment of inertia of arch panel, inches to the fourth power, per foot ( $\text{mm}^4/\text{mm}$ ) width of arch panel, or per rib section.

$Q$  = first moment about neutral axis of area of parallel grain material from panel face into plane at which shear stress is to be calculated, inches cubed per foot ( $\text{mm}^3/\text{mm}$ ) width of arch panel, or per rib section.

$S$  = shear stress, pounds per square inch ( $\text{N}/\text{mm}^2$ ), either rolling shear in plywood, or horizontal shear in rib.

$V$  = shear acting normal to the slope of the arch, pounds per foot ( $\text{N}/\text{mm}$ ) of arch width, or per rib section.

**2345.7.4 Connections.** Connections of panels to supporting members shall be with nails, lag screws, bolts, or other means adequate to resist the maximum horizontal thrust and uplift, as well as any shear developed by assumed diaphragm action.

**2345.7.5 Supports.** The horizontal members supporting arch panels shall be adequate to resist vertical and horizontal loads between supports without deflection sufficient to alter the design basis of the arch panels. Horizontal thrust shall be resisted by properly designed tie rods, struts or abutments.

Where tie rods are used to resist thrust, such rods or other effective means of resisting thrust shall be placed in all bays.

Where abutments are used at the outer edges of exterior bays, struts or other means of resisting thrust, such as shear walls, shall be placed in all bays. Spacing shall be as required by the interior panel supporting members. Such struts are required to provide for unbalanced loads when all bays are not equally loaded.

**2345.7.6 Buckling.** Adequate design provisions shall be provided to ensure stability against buckling due to axial and/or shear forces.

## SECTION 2346 — PLYWOOD BEAMS

**2346.1 Scope.** This standard covers requirements for design of plywood beams as referred to in Section 2313.

**2346.2 Definition.** Plywood beams are structural units consisting of one or more vertical plywood webs which are attached to lumber flanges. The lumber flanges carry the bending forces while the plywood webs transmit the shear. At intervals along the beam, stiffeners, inserted between the flanges and attached to the webs, serve to distribute concentrated loads and resist web buckling.

### 2346.3 Flanges.

#### 2346.3.1 Design.

**2346.3.1.1 Bending in symmetrical sections.** The allowable resisting moment for a symmetrical section shall not exceed the values established by the following formula:

$$M = \frac{2tI}{h}$$

#### WHERE:

$h$  = depth of the beam in inches (mm).

$I$  = net moment of inertia in inches to the fourth power ( $\text{mm}^4$ ) of all the continuous parallel grain material in the flange and web section. Location of the neutral axis shall be calculated without considering butt joints.

$M$  = resisting moment in inch-pounds (N·mm).

$t$  = allowable working stress in pounds per square inch (N/mm<sup>2</sup>) in tension parallel to the grain of the flange lumber. Also see Sections 2346.3.1.3 and 2346.3.1.5.

**2346.3.1.2 Bending in unsymmetrical sections.** The allowable resisting moment for an unsymmetrical beam section shall not exceed the value established by the following formula:

$$M = \frac{fI}{Z}$$

**WHERE:**

$f$  = allowable working stress in pounds per square inch (N/mm<sup>2</sup>). Note that the allowable working stress for the tension flange and compression flange corresponds to allowable values for  $t$  and  $c$ , respectively. Also see Sections 2346.3.1.3 and 2346.3.1.5.

$I$  = net moment of inertia in inches to the fourth power (mm<sup>4</sup>) of all continuous parallel grain material in the flange and web section.

$M$  = resisting moment in inch-pounds (N·mm).

$Z$  = distance from the neutral axis to an outer flange fiber in inches (mm). Location of the neutral axis shall be calculated without considering butt joints.

**2346.3.1.3 Lateral support of compression flange.** The actual stress in the compression flange shall not exceed the allowable stress established by the following formula and in no case shall exceed the allowable unit stress for compression parallel to the grain:

$$\frac{P}{A} = \frac{0.3E}{\left(\frac{L}{d}\right)^2}$$

**WHERE:**

$d$  = width of the upper flange in inches (mm).

$E$  = modulus of elasticity in pounds per square inch (N/mm<sup>2</sup>) (see Table 23-I-A-1, 23-I-A-2, 23-I-A-4 or 23-I-A-5).

$L$  = distance between lateral supports of the compression flange in inches (mm).

$P/A$  = allowable compression stress parallel to the grain in pounds per square inch (N/mm<sup>2</sup>).

Bracing elements and their connections providing restraint for the compression flange shall be capable of resisting a force  $F$  applied in a horizontal direction of not less than that established by the following formula:

$$F = 0.02 A (c') \frac{L}{Lm}$$

**WHERE:**

$A$  = area of the compression flange in square inches (mm<sup>2</sup>).

$c'$  = the allowable compressive stress or the actual stress in compression in pounds per square inch (N/mm<sup>2</sup>) as governed by Section 2346.3.1

$F$  = force applied in a horizontal direction in pounds (N).

$Lm$  = maximum permissible bracing for the actual stress.

When the member is not symmetrical about the vertical neutral axis, due consideration shall be taken in the design for adequate lateral restraint.

**2346.3.1.4 Lateral stability of deep narrow beam.** The ratio  $I_x/I_y$  of the gross moment of inertia of all parallel grain material about the horizontal neutral axis to that about the vertical axis shall determine the type of bracing required as set forth in Table 23-IV-D

**2346.3.1.5 Flange splices.** Scarf joints in tension and compression flanges may be assumed fully effective for the determination of moment of inertia. Scarf joints in adjacent laminations shall be

spaced no closer than 16 times the lamination thickness, measured center to center, except that the spacing may be reduced to zero where the design indicates no bending stress.

Butt joints shall not be permitted in tension flanges except where the butted lamination is omitted in determination of the moment of inertia at that section. In addition, the moment of inertia shall be reduced at the above section where butted joints occur in adjacent laminations based upon the area reduction factors set forth in Table 23-IV-E

The allowable stress in tension flanges having butt joints shall not exceed 80 percent of the allowable code values. Compression flanges having butt joints shall be designed as required for tension flanges except that a reduction in stress is not required.

The allowable stress in flanges having finger joints shall not exceed 2,200 pounds per square inch (0.015 16 N/mm<sup>2</sup>). The portion of the joint occupied by the tips of the fingers at the cross section shall not be considered as effective.

Approved finger joints based on the performance tests set forth in ANSI/AITC A190.1 and ASTM D 3737, with the exception that the low test value be limited to twice the design stress, may be used in lieu of the preceding requirement.

**2346.3.2 Fabrication.** Flanges shall consist of one or more laminations of Douglas fir (Coast Region), West Coast hemlock or southern pine dry lumber not more than 2 inches (51 mm) thick which is stress-graded in accordance with WCLIB Standard Grading Rules No. 16 and SPIB Southern Pine Grading Rules. Finger joints may be used in lieu of scarf joints. All provisions of WCLIB Standard Grading Rules No. 16 are applicable except as further limited by Section 2346.3.1.5.

#### 2346.4 Plywood Webs.

##### 2346.4.1 Design.

**2346.4.1.1 Horizontal shear.** The allowable shear on the plywood web shall not exceed the value established by the following formula:

$$V = \frac{vI \sum t}{Q}$$

##### WHERE:

- $I$  = total moment of inertia in inches to the fourth power (mm<sup>4</sup>) about the neutral axis of all parallel grain material regardless of any butt joints.
- $Q$  = statical moment about the neutral axis of all parallel grain material regardless of any butt joints lying above (or below) the neutral axis in inches to the third power (mm<sup>3</sup>).
- $V$  = allowable total shear on the section in pounds (N).
- $v$  = allowable plywood shear stress through the panel thickness in pounds per square inch (N/mm<sup>2</sup>). See Table 23-I-B and Section 2346.4.1.4.
- $\sum t$  = total shear thickness of all webs at the section in inches (mm).

**2346.4.1.2 Flange-web shear (rolling shear).** For beams having one or two webs, the allowable flange-web shear on pressure-glued or nail-glued systems shall not exceed the value established by the following formula:

$$V = \left( \frac{nsdI}{Q_n} \right)$$

##### WHERE:

- $d$  = depth of contact area between flange and plywood web in inches (mm).
- $I$  = total moment of inertia about the neutral axis of all parallel grain material, regardless of any butt joints in inches to the fourth power (mm<sup>4</sup>).

- $n$  = number of contact surfaces between web and flange.
- $Q_n$  = statical moment about the neutral axis of all parallel grain material, regardless of any butt joints, in the upper (or lower) flanges in inches to the third power ( $\text{mm}^3$ ).
- $s$  = one half of the allowable plywood rolling shear stress in pounds per square inch ( $\text{N}/\text{mm}^2$ ) as given in Table 23-I-B. Shear values shall not be assigned to the nails in the nail-glued systems.
- $V$  = allowable total shear on the section in pounds (N).

**2346.4.1.3 Stiffeners for concentrated loads.** Stiffeners shall be placed over reactions and where other heavy concentrated loads occur. They shall fit tightly against the flanges and their attachment to the webs shall be capable of transmitting the concentrated load or reaction. The width of the stiffeners shall be equal to the lumber flange width at the section. Their dimension parallel to the beam span shall not be less than “ $w$ .”

$$w = \frac{P}{c_{\perp} b}$$

**WHERE:**

- $b$  = flange width in inches (mm).
- $c_{\perp}$  = allowable stress in compression perpendicular to grain in pounds per square inch ( $\text{N}/\text{mm}^2$ ) for the flange lumber as set forth in Table 23-I-A-1, 23-I-A-2, 23-I-A-3, 23-I-A-4, 23-I-A-5 or 23-I-A-6.
- $P$  = concentrated load or reaction in pounds (N).

**2346.4.1.4 Intermediate stiffeners to prevent web buckling.** Intermediate stiffeners shall be spaced not to exceed 48 inches (1219 mm) on center. The width of the stiffeners shall be equal to the lumber flange width at the section and shall be of not less than 2-inch (51 mm) nominal dimensioned lumber.

In regions of high shear, where shear stress is 100 percent of values set forth in Table 23-I-A-2, the spacing of the stiffeners specified above shall be reduced in accordance with Table 23-IV-F.

Where the webs are stressed to less than 100 percent of the shear strength, the stiffener spacing  $b$  shall be calculated by the following formula, except that where the shear stress is 90 percent or less of the shear strength of the webs, the intermediate stiffeners may be spaced at 48 inches (1219 mm) on center. In no case shall the spacing exceed 48 inches (1219 mm).

$$b' = b \left( 1 + \frac{100 - p}{25} \right)$$

**WHERE:**

- $b$  = stiffener spacing in inches (mm) from Table 23-IV-F.
- $b'$  = actual stiffener spacing in inches (mm).
- $p$  = actual percentage of allowable plywood shear stress existing at the section.

**2346.4.1.5 Tapered beams.** Where the depth of the beam is tapered, the net vertical component of the direct forces in the flanges shall be added to or subtracted from the external shear to obtain the net shear acting at a section of web. This vertical component shall be calculated as follows:

$$P_v = \frac{M}{L_t}$$

**WHERE:**

- $L_t$  = distance from section to the intersection of the flange center lines in inches (mm).
- $M$  = bending moment acting on section in inch-pounds (N-mm).

$P_v$  = vertical component of flange in pounds (N).

**2346.4.1.6 Web splices.** Scarfed and butt end joints in plywood webs shall be designed in accordance with Part I of this standard. Joints subject to more than one type of stress or to stress reversal shall be designed for the most severe case. The slope of scarf joints, 1 in 8 or flatter, and splice plate lengths in Table 23-IV-B of this standard are adequate to transmit 100 percent of the shear strength of the plywood webs being spliced, provided that the provisions of Section 2344.4.1.3.2 regarding splice plate thickness, grade and orientation, are adhered to.

All end joints in plywood webs shall be staggered at least 24 inches (610 mm) with intermediate stiffeners at each joint.

## SECTION 2347 — PLYWOOD SANDWICH PANELS

**2347.1 Scope.** This standard covers requirements for the design of plywood sandwich panels as referred to in Section 2313.

**2347.2 Definition.** A structural sandwich panel is an assembly consisting of a lightweight core securely laminated between two relatively thin, strong facings. Axial compression forces are carried by compression in the facings, stabilized by the core material against buckling; bending moments are resisted by an internal couple composed of forces in the facings; shearing forces are resisted by the core.

### 2347.3 General Design.

**2347.3.1 Material.** For purposes of this standard, facings are assumed to be plywood meeting the requirements of U.B.C. Standard 23-2. Cores may be a variety of material, including polystyrene foams, polyurethane foams and paper honeycombs.

**2347.3.2 Bond between faces and core.** Core may be glued to faces, or in the case of some foam materials, may adhere directly to the faces during expansion. In exterior wall panels, the bond shall be waterproof. The combination of core material and bond shall be such as not to creep excessively under the long-term loads and temperatures.

**2347.3.3 Trial section.** A trial section of an exterior wall sandwich panel shall be determined as described below. It shall then be investigated for all possible modes of failure.

### 2347.4 Faces and Cores.

**2347.4.1 Plywood faces.** The required parallel-grain plywood area shall be determined by the following formula:

$$A_1 + A_2 = \frac{P}{F_c}$$

#### WHERE:

$A_1$  = parallel-grain area of outside (top) skin in in.<sup>2</sup>/ft. (mm<sup>2</sup>/mm) of width.

$A_2$  = parallel-grain area of inside (bottom) skin in in.<sup>2</sup>/ft (mm<sup>2</sup>/mm).

$F_c$  = allowable compressive stress in parallel plies of plywood in pounds per square inch (N/mm<sup>2</sup>).

$P$  = axial load in pounds per foot (N/mm) of panel width.

**2347.4.2 Core thickness.** The minimum core thickness for structural purposes shall satisfy the following formula. In practice, core thickness is usually chosen on the basis of required insulating value.

$$S = \frac{M}{F_c} = \frac{A(h + c)^2}{4h}$$

**WHERE:**

- $A$  = parallel-grain area of skin in in.<sup>2</sup>/ft. (mm<sup>2</sup>/mm) of panel width, =  $A_1 = A_2$ .
- $C$  = core thickness in inches (mm).
- $h$  = total panel thickness in inches (mm).
- $L$  = panel span in feet (mm).
- $M$  = maximum bending moment applied to panel, in lb.-in. per foot (N·m/mm) of panel width (for simply supported end conditions,  $M = 1.5wL^2$ ).
- $S$  = section modulus of panel in in.<sup>3</sup>/ft. (mm<sup>3</sup>/mm) of width.
- $w$  = normal loading in pounds per square foot (N/mm<sup>2</sup>).

**2347.5 Analysis.**

**2347.5.1 Neutral axis.** The location of the neutral axis for the panel shall be calculated from the following formula:

$$\bar{y} = \frac{A_1 \left( h - \frac{t_1}{2} \right) + A_2 \left( \frac{t_2}{2} \right)}{A_1 + A_2}$$

**WHERE:**

- $t_1$  = thickness of outside (top) skin in inches (mm).
- $t_2$  = thickness of inside (bottom) skin in inches (mm).
- $\bar{y}$  = distance from bottom (or inside) of panel to neutral axis in inches (mm).

**2347.5.2 Moment of inertia and section modulus.** Moment of inertia and section modulus shall be calculated from the following formulas:

$$I = \frac{A_1 A_2 (h + c)^2}{4 (A_1 + A_2)}$$

$$S_1 = \frac{I}{h - \bar{y}}, \quad S_2 = \frac{I}{\bar{y}}$$

**WHERE:**

- $I$  = panel moment of inertia in inches<sup>4</sup> per foot (mm<sup>4</sup>/mm) of width.
- $S_1$  = section modulus calculated from the compression side of the panel, in inches<sup>3</sup> (mm<sup>3</sup>).
- $S_2$  = section modulus calculated from the tension side of the panel, in inches<sup>3</sup> (mm<sup>3</sup>).

**2347.5.3 Column buckling.** Allowable axial load shall be no larger than the value calculated from the following formula:

$$P_{cr} = \frac{\pi^2 EI}{(12L)^2 \left[ 1 + \frac{\pi^2 EI}{(12L)^2 \times 6(h + c)G_c} \right]}$$

For SI:

$$P_{cr} = \frac{\pi^2 EI}{L^2 \left[ 1 + \frac{2\pi^2 EI}{L^2(h + c)G_c} \right]}$$

**WHERE:**

- $E$  = modulus of elasticity of plywood in pounds per square inch (N/mm<sup>2</sup>). This value should include a 10 percent increase over published data to restore an allowance made when shear deflection is not computed separately.

$G_c$  = modulus of rigidity of core in direction of span, in pounds per square inch (N/mm<sup>2</sup>).

$P_{cr}$  = theoretical column buckling load in pounds per foot (N/mm) of panel width.

**2347.5.4 Skin buckling.** Stress tending to cause buckling of skin shall be no larger than that given in the following formula:

$$C_{cr} = 0.5 \sqrt[3]{EE_c G_c}$$

**WHERE:**

$C_{cr}$  = theoretical skin buckling stress in pounds per square inch (N/mm<sup>2</sup>).

$E_c$  = modulus of elasticity of the core perpendicular to the skin, in pounds per square inch (N/mm<sup>2</sup>).

**2347.5.5 Deflection.** The maximum deflection shall conform to Table 16-D. Deflection shall be calculated according to the following formulas.

Deflection due to transverse loading only is equal to:

$$\Delta = \Delta_b + \Delta_s = \frac{5wL^4 \times 1728}{384EI} + \frac{wL^2}{4(h+c)G_c}$$

For SI: 
$$\Delta = \Delta_b + \Delta_s = \frac{5wL^4}{384EI} + \frac{wL^2}{4(h+c)G_c}$$

**WHERE:**

$\Delta$  = total deflection in inches (mm).

$\Delta_b$  = deflection due to loading.

$\Delta_s$  = deflection due to shear.

Total deflection including effects of axial load is approximately equal to:

$$\Delta_{\max} = \frac{\Delta}{1 - P/P_{cr}}$$

**WHERE:**

$\Delta_{\max}$  = maximum deflection in inches (mm).

**2347.5.6 Bending stress.** Bending stress shall be calculated using the following formula. This stress includes the bending due to the axial load through the initial transverse load deflection.

$$f_{b \max} = \frac{1.5wL^2 + P\Delta_{\max}}{S_1}$$

**WHERE:**

$f_{b \max}$  = applied bending stress in the facings.

**2347.5.7 Combined stress.** Maximum combined stress will occur at midlength or midheight of the panel. It is the sum of the axial stress and the compressive bending stress in the concave side of the panel. It shall be calculated in accordance with the following formula:

$$f_{c \max} = \frac{P}{A_1 + A_2} + f_{b \max}$$

**WHERE:**

$f_{c \max}$  = maximum combined stress in pounds per square inch (N/mm<sup>2</sup>) (compression).

This stress shall be less than  $F_c$  and less than  $1/3C_{cr}$ .

**2347.5.8 Shear stress.** Shear stress shall be computed by the formula:

$$f_v = \frac{wL}{(h + c)12} \leq F_v$$

For SI:

$$f_v = \frac{wL}{(h + c)} \leq F_v$$

**WHERE:**

$f_v$  = applied shear stress in the core, in pounds per square inch (N/mm<sup>2</sup>).

$F_v$  = allowable shear stress in the core, in pounds per square inch (N/mm<sup>2</sup>).

**SECTION 2348 — FABRICATION OF PLYWOOD COMPONENTS**

**2348.1 Scope.** This standard applies to the fabrication of glued plywood-lumber structural assemblies such as stressed skin panels, curved panels, beams, etc., that have been designed in accordance with accepted engineering principles, including Division IV, Sections 2344, 2345 and 2346, for stressed skin panels, curved panels and beams.

**2348.2 Materials.**

**2348.2.1 Plywood.**

**2348.2.1.1 General.** Plywood shall be as specified in the design and conform to U.B.C. Standard 23-2. Each original panel shall bear the grade trademark of an approved independent inspection and testing agency.

**2348.2.1.2 Type.** When the equilibrium moisture content of the member in use exceeds 16 percent or if any edge or surface of the plywood is permanently exposed to the weather, the plywood affected shall be exterior type. Otherwise, it may be interior type with exterior glue.

**2348.2.1.3 Moisture content.** At time of gluing the plywood shall be conditioned to a moisture content of approximately that which it will attain in service, but shall be between 7 percent and 16 percent. Difference in average moisture content between panels glued to each other in any member shall not exceed 5 percent.

**2348.2.1.4 Surface requirements.** Surfaces of plywood to be glued shall be clean and free from oil, dust, paper tape and other material which would be detrimental to satisfactory gluing.

Medium density overlaid surfaces shall not be relied on for a structural glue bond.

**2348.2.1.5 Dimensional tolerances.** Scarfed panels of plywood shall be square, as measured on the diagonals, within  $1/8$  inch (3.8 mm) for a 4-foot-wide (1219 mm) panel, and proportionately for other widths.

**2348.2.2 Lumber.**

**2348.2.2.1 Grading.** Lumber shall be uniformly manufactured and shall be of the grade required by the design. Lumber shall be graded and grade marked in accordance with applicable U.B.C. standards for the species to be used, except as modified herein.

When lumber is resawn, it shall be regraded and grade marked on the basis of the new size.

**2348.2.2.2 Knotholes.** Knotholes to the same size as the sound and tight knots specified for the grade by applicable U.B.C. standards may be permitted.

**2348.2.2.3 Moisture content.** At time of gluing, the lumber shall be conditioned to a moisture content of approximately that which it will attain in service, but shall be between 7 percent and 16 percent.

The range of moisture content of the various pieces assembled into a single panel or flange of a beam shall not exceed 5 percent.

**2348.2.2.4 Surface requirements.** Surfaces of lumber to be glued shall be clean and free from oil, dust and other foreign matter which would be detrimental to satisfactory gluing.

Each piece of lumber shall be machine finished, but not sanded, to a smooth surface with a maximum allowable variation of  $\frac{1}{64}$  inch (0.40 mm) in the surface to be glued.

Warp, twist, cup or other characteristics which would prevent intimate contact of adjacent glued surfaces shall not be permitted.

**2348.2.2.5 Flanges.** Lumber for laminated flanges of beams and ribs for curved panels shall conform with the applicable requirements of ANSI/AITC Standard A190.1 and ASTM D 3737 regardless of the number of laminations.

**2348.2.2.6 Transverse members.** Lumber for headers, blocking and stiffeners shall be of minimum 2-inch (51 mm) nominal thickness and Standard Grade or higher Douglas fir or West Coast hemlock or equal.

### 2348.2.3 Glue.

**2348.2.3.1 General.** Mixing, spreading, storage life, pot life and working life, and assembly time and temperature shall be in accordance with the manufacturer's recommendations.

**2348.2.3.2 Interior type.** When the equilibrium moisture content of the member in use does not exceed 16 percent, glue may be casein type, containing a mold inhibitor, and conforming with ASTM D 3024.

**2348.2.3.3 Exterior type.** When the equilibrium moisture content of the member in use exceeds 16 percent, glue shall be of a phenol, resorcinol or melamine base and conform with ASTM D 3024 and D 2559 and APA AFG-01.

### 2348.3 Fabrication.

**2348.3.1 General.** Units may be assembled in a one-step process using either nail-gluing or mechanical pressure including pressure from clamps, presses, or other reasonably uniform measurable pressure, externally applied, to attach the plywood to the framing. If the unit is longer than available lengths of plywood, the skins and webs shall be spliced to full length, either with scarf joints, or butt joints with glued splice plates. Flange laminations of beams having glue lines parallel to the web may be glued at the same time as webs or preassembled. In either case, the laminating shall conform to the applicable requirements of ANSI/AITC Standard A190.1 and ASTM D 3737.

If more than one unit is pressed at a time, care shall be taken to prevent distortion of any core material used in the assembly.

All cutouts for openings shall be reinforced as required in the design.

**2348.3.2 Surfacing.** The edges of framing members to which plywood skins or webs are to be glued shall be surfaced prior to assembly so that the members have a maximum variation in surface of  $\frac{1}{64}$  inch (0.4 mm) and  $\frac{1}{32}$  inch (0.8 mm) in depth for all framing members (allowing for actual thickness of any splice plates superimposed on blocking). This variation in depth shall apply to each framing member, as well as to the entire group of framing members within a unit.

Stiffeners for glued beams shall be surfaced prior to gluing so that their surfaces are flush with those of the flanges within  $\frac{1}{32}$  inch (0.8 mm), allowing for any superimposed plywood splice plates.

For glued beams, flanges at all stiffener locations shall have a maximum deviation from square of  $\frac{1}{16}$  inch (1.6 mm) in 6 inches (152 mm), measured perpendicular to an accurate square gage. Twist or bow which would prevent intimate contact of webs, or would cause the beam to deform, shall not be permitted.

Surfaces of high density overlaid plywood to be glued shall be roughened, as by a light sanding, before gluing.

**2348.3.3 Glued joints.** Plywood skins and webs shall be glued to all framing members over their full contact area, except that solid core curved panels may have the width and spacing of the contact area specified in the design.

All splice plates at butt joints in plywood skins and webs and all scarfed end joints shall be glued over their full contact area. Scarf joints shall be glued, under pressure, and those plywood surfaces in contact with the framing members shall be sanded smooth with tape removed prior to assembly.

**2348.3.4 End joints in lumber.**

**2348.3.4.1 General.** End joints in stringers, ribs and flange material, including shims, shall be as specified in the design for the grade and stress used.

**2348.3.4.2 Scarf joints.** Scarf joints in the lumber flanges shall be well scattered throughout. Unless otherwise specified, in adjoining laminations they shall be spaced not closer than 16 times the lamination thickness, measured from center to center. If shown on the approved plans, this spacing may be decreased to zero where the design indicates no bending stress. In flanges of three or less laminations, only one scarf joint shall be allowed at any one cross section; in flanges of four or more laminations, two scarf joints shall be allowed at the same cross section. Scarf slopes shall not be steeper than 1 in 10 unless otherwise permitted by the design.

**2348.3.4.3 Butt joints.** Stringer, rib and flange laminations shall not be butt jointed unless specified in the design. If permitted and not otherwise stipulated in the design, they shall be spaced at least 30 times the lamination thickness in adjoining (actually touching) laminations, and at least 10 times the lamination thickness in nonadjoining laminations.

**2348.3.5 End joints in plywood.**

**2348.3.5.1 Scarf joints.** When a skin or web is composed of panels less than full length, end joints shall be scarfed and glued, unless butt joints with plywood splice plates are permitted by the design. Slope of scarf joints shall not be steeper than 1 in 8.

**2348.3.5.2 Butt joints in skins of panels.** Butt joints shall be backed with plywood splice plates glued to one side of the skin. For ribbed panels, when glued during panel assembly the splice plate shall be backed with one or more pieces of lumber blocking, accurately machined in width so as to obtain adequate pressure. Lumber blocking by itself shall not be used for splicing skins unless shown on the approved plans.

Splice plates shall be centered over the butt joint, and shall have their grain parallel with that of the skin. Plates shall extend to within  $\frac{1}{4}$  inch (6.4 mm) of the ribs; the latter shall not be notched to receive them, unless permitted by the design. Splice plates shall be at least equal in thickness to the skin, except that minimum thickness shall be  $\frac{1}{2}$  inch (13 mm) if nail- or staple-glued. Minimum splice plate lengths shall be as shown in Table 23-IV-B.

Solid plywood core panels shall be scarf jointed to length if so specified by the design. If designated on the approved plans, joints in solid plywood core panels may be tightly butted, provided they will conform readily with the curvature of the surface. Spacing of butt joints shall not be less than 10 times the lamination thickness.

**2348.3.5.3 Butt joints in webs of beams.** Butt joints shall be staggered at least 24 inches (610 mm).

Splices at butt joints in webs shall be in accordance with the design. Unless otherwise noted in the design, at all web butt joints a plywood shear splice plate shall be centered over the joint and pre-glued prior to assembly. The plate shall extend to within  $\frac{1}{4}$  inch (6.4 mm) of each flange on the inside of the beam, shall be at least equal in thickness to the web being spliced, of a length as specified on the approved plans, and shall have its grain parallel to that of the web. No splice plate

shall consist of more than two pieces of plywood. Where the design provides for the stiffeners to act as the web splices, web butt joints shall be located over the center of the stiffener, within  $\frac{1}{16}$  inch (1.6 mm), and webs shall be glued to the stiffener. The stiffener alone may be used as a splice plate when the web is 24 inches (610 mm) deep or less, and is no thicker than  $\frac{3}{8}$  inch (9.5 mm), or carries no more shear than would be allowed on a  $\frac{3}{8}$ -inch (9.5 mm) panel.

**2348.3.6 Stiffener location for beams.** Stiffeners shall be placed as shown on the approved plans, but in any case they shall be spaced not to exceed 4 feet (1219 mm) on centers, and at reactions and other concentrated load joints.

Stiffeners shall be held in tight contact with the flanges by positive lateral pressure during fabrication.

**2348.3.7 Assembly.** Ribs, stringers, flanges and other framing members shall be assembled accurately and shall be square. Joints shall be made tight, and all framing members shall be of uniform thickness within  $\frac{1}{32}$  inch (0.8 mm).

All gluing surfaces shall be flush within  $\frac{1}{32}$  inch (0.8 mm).

Plywood may be lightly tacked to framing members so as to maintain alignment during pressing.

**2348.3.8 Tongue-and-groove edge joint.** Where a tongue-and-groove-type edge joint for stressed skin and curved panels is specified (and not otherwise detailed), the longitudinal framing member forming the tongue shall be of at least 2-inch (51 mm) nominal thickness, set out  $\frac{3}{4}$  inch (19 mm) from the plywood edge plus or minus  $\frac{1}{16}$  inch (1.6 mm). Edges of the tongue shall be eased so as to leave a flat shoulder at least  $\frac{3}{8}$  inch (9.5 mm) wide. Any corresponding framing member forming the base of the groove shall be set back  $\frac{1}{4}$  inch to 1 inch (6.4 mm to 25 mm) more than the amount by which the tongue protrudes. Abutting plywood edges may be chamfered. One face may be cut back  $\frac{1}{16}$  inch (1.6 mm) to provide a tight fit for the opposite face.

**2348.3.9 Nail- and pressure-gluing.** Curved units shall be laminated over a form. Means shall be used that will provide close contact and substantially uniform pressure on panels and beams. Application of pressure or nailing may start at any point, but shall progress to an end or ends. Movement of the units shall not be permitted while the glue is setting.

Where clamping or other positive mechanical means are used, the pressure on the net framing area shall be sufficient to provide adequate contact and ensure good glue bond. Pressure shall be uniformly distributed by caul plates, beams or other effective means.

In place of mechanical pressure methods, nail-gluing may be used for bonding plywood to lumber and plywood to plywood, but shall not be used for bonding lumber to lumber. Regardless of the method used, the resulting glue line must meet the required standards. Nails shall be at least 4d for plywood up to  $\frac{3}{8}$  inch (9.5 mm) thick, and 6d for  $\frac{1}{2}$ -inch to  $\frac{7}{8}$ -inch (13 mm to 22 mm) plywood, and 8d for 1-inch to  $1\frac{1}{8}$ -inch (25 mm to 29 mm) plywood. Nails shall be spaced not to exceed 3 inches (76 mm) along the ribs for plywood through  $\frac{3}{8}$  inch (9.5 mm), or 4 inches (102 mm) for plywood  $\frac{1}{2}$  inch (13 mm) and thicker, using one line for glue lines 2 inches (51 mm) wide or less, two lines for glue lines more than 2 inches (51 mm) wide and up to 4 inches (102 mm) wide, three lines for glue lines up to 10 inches (254 mm) wide and four lines for 12-inch-wide (305 mm) glue lines. (If shorter nail lengths are used in order to avoid penetrating the opposite face, spacing shall be decreased in proportion to actual penetration.)

Panels having solid plywood cores may be glued using staples or nails, following a schedule of demonstrated effectiveness, but in no case spaced farther apart than 6 inches (152 mm) both ways. Length of fasteners is limited by the available thickness of the laminations. Additional nailing, into temporary solid framing, may be required to provide close contact for adequate glue bonds.

In any case, it shall be the responsibility of the fabricator to produce a glue bond which meets or exceeds the requirements of this division.

**2348.3.10 Insulation and ventilation.** In hollow panels, insulating and vapor-barrier materials and ventilation provided as specified in the design shall be securely fastened in the assembly in such

a way that they cannot interfere with the process of gluing the plywood skins to the framing members or with the ventilation pattern.

When specified, longitudinal sections shall be vented through blocking and headers on the cool side of the insulation. Provision shall be made to line up the ventholes in assembling panels, with a definite ventilation pattern leading to the outdoors. Framing members shall not be notched for ventilation, unless shown on the approved plans.

**2348.4 Identification.** Each member shall be identified by the appropriate trademark of the approved independent inspection and testing agency, legibly applied so as to be clearly visible. If the strength of one surface of a beam or panel is different from the other, the top surface shall be identified.

**2348.5 Test Samples.** When glue bond test samples are taken from a member and from trim, they shall be taken as cores approximately 2 inches (51 mm) in diameter, drilled perpendicular to the plane of the skins or webs, and no deeper than  $\frac{3}{4}$  inch (19 mm) into any framing member. Samples at beam flanges shall be taken from the ends of the beams only. Centers of cores shall normally be located in the top corner of the beam at points within 2 inches (51 mm) from one edge and up to 6 inches (152 mm) from the other.

No samples shall be taken from the same skin or web closer together than 12 inches (305 mm), except as detailed in Exception 2. Samples shall be taken at a distance from the panel ends not greater than the panel depth.

**EXCEPTIONS:** 1. One sample may be taken from one of the outside longitudinal framing members, within the outer fourth points of the panel length, provided the framing member is notched no deeper than  $\frac{1}{2}$  inch (13 mm) below its edge. The other outside longitudinal framing member may be sampled similarly, but at the opposite end of the panel.

2. Two samples per butt joint at any one cross section may be taken from skin or web splice plates. They shall be located midway between longitudinal framing members, and shall be aligned longitudinally, one on each side of the butt joint.

Samples through beam web splice plates shall be taken within the middle half of the span, at the center line of the beam depth.

Where the core of curved panels consists of solid plywood or a solid core material, only one core shall be taken at any one cross section. Cross sections shall be no closer than 12 inches (305 mm) along the arc. Not more than four cores shall be taken from a 4-foot-wide (1219 mm) panel, with a proportionate number limited to other widths. Ribs in such panels shall be sampled as required by this section, except that at ribs the core shall not extend more than  $\frac{3}{4}$  inch (19 mm) into the rib.

Samples may be taken from other locations when approved by the building official.

#### **2348.6 Testing of Glued Joints.**

**2348.6.1 General.** This section shall govern all glued joints which have not been subjected to prior inspection and testing such as the glue line between plywood and lumber as contained in ASTM D 1101 and AITC 200. These joints shall be referred to as “secondary” glue lines. Glued joints subjected to prior testing such as those in plywood shall be referred to as “primary” glue lines. Before testing, specimens shall be allowed to cure.

All secondary glue line testing shall be performed by approved testing agencies. Test specimens containing localized defects permitted by the grade of the material involved shall be discarded.

#### **2348.6.2 Lumber-plywood side grain combinations.**

**2348.6.2.1 Selection of test samples.** Lumber-plywood side grain samples shall be taken from members selected at random. They shall consist of 2-inch-diameter (51 mm) core of adequate depth and location to yield sufficient material on both sides of the secondary glue line.

Members to be sampled shall be selected to include production variables such as different lots of material, glue batches, shifts and crews.

Trim may be acceptable in lieu of cores for sampling purposes if it is truly representative of the member.

**2348.6.2.2 Dry shear strength testing.** Lumber and plywood side grain specimens shall be tested in a block shear tool with the load applied through a self-aligning seat to ensure uniform lateral distribution of the load. Rate of load application shall be 0.2 inch (5.1 mm) per minute. Ultimate load shall be read to the nearest 5 pounds (22.2 N) and wood failure shall be determined to the nearest 5 percent.

**2348.6.2.3 Durability testing.**

**2348.6.2.3.1 Interior.** This test method shall be used in all cases where the durability requirement for the completed component is Interior.

Lumber and plywood side grain specimens shall be submerged in water at room temperature for a period of four hours and then dried at a temperature between 100°F. and 105°F. (37.8°C. and 40.6°C.) for a period of 19 hours with sufficient air circulation in drying cabinet to lower moisture content of specimen to a maximum of 8 percent based on oven-dry weight. This test procedure shall be conducted through three cycles, unless all specimens have failed. All specimens shall be inspected after the first and third cycles and all failures recorded. Total continuous delamination 1 inch (25 mm) along the edge of the test specimen and 1/4 inch (6.4 mm) deep shall be considered as failure.

**2348.6.2.3.2 Exterior.** This test method shall be used where the test specimen contains exterior-type adhesives throughout and where the durability requirement for the completed component is Exterior.

Lumber and plywood specimens shall be cycled by one of the following methods:

1. **Cold soak.** Test specimens shall be submerged in water at room temperature for 48 hours and then dried for eight hours at a temperature of 145°F. (62.8°C.) [ $\pm$  5°F. (2.8°C.)], followed by two cycles of soaking for 16 hours and drying for eight hours under conditions described above. The specimens shall be soaked again for a period of 16 hours.

2. **Vacuum pressure.** Place the specimens in the pressure vessel and weight them down. Admit water at a temperature of 65°F. to 80°F. (18.3°C. to 26.7°C.) in sufficient quantity so that the specimens are completely submerged. Separate the specimens by stickers, wire screens or other means in such a manner that all end grain surfaces are freely exposed to the water. Draw a vacuum of 20 inches to 25 inches (67.5 kPa to 84.4 kPa) of mercury (at sea level) and hold for 30 minutes. Release the vacuum and apply a pressure of 40 plus or minus 5 pounds per square inch (275.8 kPa  $\pm$  34.5 kPa) for two hours.

While still wet the specimens shall be tested in accordance with the method specified above in Section 2348.6.2.2.

**2348.6.2.4 Performance requirements.**

**2348.6.2.4.1 General.** The minimum performance requirements for laboratory testing of all side grain glue joint specimens shall be as specified in this subsection. If two or more grain orientations are present in any one test run or combinations of test runs, an adjusted average shear stress performance requirement shall be computed by the weighted average method.

**2348.6.2.4.2 Dry shear strength requirements.** The specimens shall have an average dry strength shear stress as set forth in Table 23-IV-G.

**2348.6.2.4.3 Interior durability requirement.** Ninety-five percent of all specimens shall pass the first cycle and 85 percent shall pass three cycles.

**2348.6.2.4.4 Exterior durability requirement.** Eighty-five percent of more wood failure shall be required for the overall average. Ninety percent of all specimens tested shall show 60 percent or

more wood failure, 80 percent of all specimens tested shall show 80 percent or more wood failure. Failure in any part of test specimen, except glue failure in the secondary glue bond tested, is wood failure.

**2348.6.3 Lumber end joints.**

**2348.6.3.1 General.** Plain scarf joints and finger joints shall be tested in accordance with the provisions of ASTM D1101 and AITC 200.

**2348.6.3.2 Selection of test samples.** Test samples shall be obtained from full-size joints, or from scarf joints selected at random from routine production. The latter shall be taken from the center line of the lamination containing the scarf being sampled. No more than one sample shall be taken from any component cross section and scarf samples shall not be closer than 4 feet (1219 mm).

**2348.6.3.3 Dry tension testing.** Specimens shall be tested in accordance with AITC 200.

**2348.6.3.4 Durability testing.**

**2348.6.3.4.1 Interior.** Test specimens shall be submerged in water at room temperature for a period of four hours and then dried at a temperature between 100°F. and 105°F. (37.8°C. and 40.6°C.) for a period of 19 hours with sufficient air circulation in drying cabinet to lower moisture content of specimen to a maximum of 8 percent based on oven-dry weight. This test procedure shall be conducted through three cycles, unless all specimens have failed.

The specimens then shall be tested dry in accordance with AITC 200.

**2348.6.3.4.2 Exterior.** Test specimens shall be cycled by one of the following methods:

1. **Cold soak.** Test specimens shall be submerged in water at room temperature for 48 hours and then dried for eight hours at a temperature of 145°F. (62.8°C.) [ $\pm 5^\circ\text{F}$ . (2.8°C.)], followed by two cycles of soaking for 16 hours and drying for eight hours under conditions described above. The specimens shall be soaked again for a period of 16 hours.

2. **Vacuum pressure.** Place the specimens in the pressure vessel and weight them down. Admit water at a temperature of 65°F. to 80°F. (18.3°C. to 26.7°C.) in sufficient quantity so that the specimens are completely submerged. Separate the specimens by stickers, wire screens, or other means in such a manner that all end grain surfaces are freely exposed to the water. Draw a vacuum of 20 inches to 25 inches (67.5 kPa to 84.4 kPa) of mercury (at sea level) and hold for 30 minutes. Release the vacuum and apply a pressure of 40 plus or minus 5 pounds per square inch (275.8 kPa  $\pm$  34.5 kPa) for two hours.

The specimens shall then be tested wet in accordance with AITC 200.

**2348.6.3.5 Performance requirements.**

**2348.6.3.5.1 General.** The minimum performance requirements for laboratory testing of all lumber end joint specimens shall be as specified in this subsection.

**2348.6.3.5.2 Dry tension stress requirements.** The test specimens shall have the tension stresses set forth in Table 23-IV-H. No test value shall be less than twice the normal allowable stress.

Dry tension wood failure requirements regardless of species shall average not less than 80 percent except tests averaging at least 10,000 pounds per square inch (69 N/mm<sup>2</sup>) in tension shall not have less than 70 percent. The minimum requirement for 90 percent of the individual specimens shall not be less than 40 percent wood failure.

**2348.6.3.5.3 Interior durability requirement.** Average wood failure shall not be less than 70 percent.

**2348.6.3.5.4 Exterior durability requirement.** Average wood failure shall not be less than 85 percent and the minimum requirement for 90 percent of the individual specimens shall not be less than 50 percent.

**2348.6.4 Plywood end joints.**

**2348.6.4.1 General.** Plain plywood scarf joints shall be tested in accordance with the provisions of this section. Splice butt joints shall be tested as specified in Section 2348.6.2.

**2348.6.4.2 Selection of test samples.** Full width scarfs shall be selected at random from routine production. A minimum of 2 percent of the scarfs produced shall be sampled. At least 20 specimens suitable for testing shall be obtained from each 4 feet (1219 mm) of scarf. They shall be equally distributed across the width.

**2348.6.4.3 Dry tension.** Specimens shall be tested in a tension machine equipped with wedge-type grips. Dry tension specimens shall be loaded at a rate of 0.4 inch (10 mm) per minute. Ultimate load shall be read to the nearest 5 pounds (22.2 N) and wood failure on the joined surface estimated to the nearest 5 percent. Wood failure shall be estimated on the scarf surface of the plies parallel to the direction of the tension load.

**2348.6.4.4 Durability.**

**2348.6.4.4.1 Interior.** Interior durability test specimens shall be sub-merged in water at room temperature for a period of four hours and then dried at a temperature between 100°F. and 105°F. (37.8°C. and 40.6°C.) for a period of 19 hours with sufficient air circulation in drying cabinet to lower moisture content of specimen to a maximum of 8 percent based on oven-dry weight. This test procedure shall be conducted through three cycles, unless all specimens have failed. Test specimens showing delamination on the face or end in excess of  $\frac{1}{16}$  inch (1.6 mm) deep and  $\frac{1}{2}$  inch (13 mm) long at the scarf glue line shall be considered as failing.

**2348.6.4.4.2 Exterior.** Exterior durability test specimens shall be cycled by one of the following methods:

1. **Cold soak.** Test specimens shall be submerged in water at room temperature for 48 hours and then dried for eight hours at a temperature of 145°F. (62.8°C.) [ $\pm 5^\circ\text{F. (2.8}^\circ\text{C.)}$ ], followed by two cycles of soaking for 16 hours and drying for eight hours under conditions described above. The specimens shall be soaked again for a period of 16 hours.

2. **Vacuum pressure.** Place the specimens in the pressure vessel and weight them down. Admit water at a temperature of 65°F. to 80°F. (18.3°C. to 26.7°C.) in sufficient quantity so that the specimens are completely submerged. Separate the specimens by stickers, wire screens, or other means in such a manner that all end grain surfaces are freely exposed to the water. Draw a vacuum of 20 inches to 25 inches of mercury (67.5 kPa to 84.4 kPa) (at sea level) and hold for 30 minutes. Release the vacuum and apply a pressure of  $40 \pm 5$  pounds per square inch (275.8 kPa  $\pm$  34.5 kPa) for two hours.

While still wet, the specimens shall be tested in a tension machine equipped with wedge-type grips. Dry tension specimens shall be loaded at a rate of 0.4 inch (10 mm) per minute. Ultimate load shall be read to the nearest 5 pounds (22.2 N) and wood failure on the joined surface estimated to the nearest 5 percent.

**2348.6.4.5 Performance requirements.**

**2348.6.4.5.1 General.** The minimum performance requirements for laboratory testing of all lumber end joint specimens shall be as specified in this subsection.

**2348.6.4.5.2 Dry tension stress.** The average tension stress for Group 1 shall be 4,000 pounds per square inch (28 N/mm<sup>2</sup>); for Groups 2 and 3, 2,800 pounds per square inch (19 N/mm<sup>2</sup>); and 2,400 pounds per square inch (17 N/mm<sup>2</sup>) for Group 4, all adjusted as required for inner ply species. Regardless of species, wood failure shall average not less than 80 percent and the minimum requirement for 90 percent of the individual test specimens shall not be less than 50 percent.

**2348.6.4.5.3 Durability requirements.**

1. **Interior.** Ninety-five percent of all test specimens shall pass one cycle and 85 percent shall pass three cycles.

2. **Exterior.** Average wood failure shall not be less than 85 percent.

### SECTION 2349 — ALL-PLYWOOD BEAMS

**2349.1 Scope.** This part covers requirements for the design of all-plywood beams as referred to in Section 2313.

**2349.2 Definition.** All-plywood beams are staple-glued structural units consisting of one or more vertical layers of butt-jointed plywood for webs which resist both bending and shear forces. Plywood web splice plates located at web joints, and/or one or more vertical layers of butt-jointed plywood for flanges, may also be staple glued to the webs for added resistance to shear and bending forces, if necessary. Plywood web stiffeners are staple-glued to single-layer webs to distribute concentrated loads and resist web buckling at end supports and interior concentrated load points. (For design of plywood beams consisting of plywood webs attached to lumber flanges, see Section 2346 of this division.

**2349.3 Allowable Stresses.** Allowable stresses for plywood used in all-plywood beams shall not exceed the values set forth in Table 23-I-B, except that allowable bending stress may be multiplied by 2 for five-ply, five-layer plywood, and by 1.7 for three-, four- or five-ply, three-layer plywood. Five-ply, five-layer plywood with butt-jointed center ply shall be considered as three-layer plywood for design purposes.

**2349.4 Design.**

**2349.4.1 Bending.** The allowable resisting moment for a beam section shall not exceed the value established by the following formula:

$$M = \frac{fI}{Z}$$

**WHERE:**

$f$  = allowable working stress in bending for plywood, in pounds per square inch (N/mm<sup>2</sup>). Also, see Section 2349.3.

$I$  = the minimum net moment of inertia, in inches to the fourth power (mm<sup>4</sup>), of all continuous parallel grain material at any beam section containing a web or flange butt joint. Location of the neutral axis shall be calculated without considering butt joints in the web or flanges (if used). Also, see Section 2349.6.2. A web splice plate (if used) shall be included in the net amount of inertia only if directly glued to the web layer containing the butt joint.

$M$  = resisting moment in inch-pounds (N·mm).

$Z$  = distance in inches (mm) from the neutral axis to the extreme fiber in bending.

**2349.4.2 Horizontal shear.** The allowable shear on the plywood web shall not exceed the value established by the following formula:

$$V = \frac{vI \sum t}{Q}$$

**WHERE:**

$I$  = total moment of inertia, in inches to the fourth power (mm<sup>4</sup>), of all parallel grain material in the web and flanges regardless of butt joints. Stiffeners or web splice plates shall be disregarded.

$Q$  = statical moment about the neutral axis, in inches to the third power (mm<sup>3</sup>), of all parallel grain material in the web and flanges, regardless of butt joints, lying above (or below) the neutral axis. Stiffeners or web splice plates shall be disregarded.

$V$  = allowable total shear on the section, in pounds (N). Loads may be disregarded that are located within a distance from the support equal to the beam depth.

$v$  = allowable plywood shear stress through the panel thickness, in pounds per square inch (N/mm<sup>2</sup>).

$\sum t$  = total shear thickness of continuous webs (and/or web splice plates and stiffeners, if applicable) at the neutral axis of the section, in inches (mm). Also, see Section 2349.6.2.

**2349.4.3 Flange-web shear (rolling shear).** For beams containing plywood flanges, the allowable flange-web shear on glued joints shall not exceed the value established by the following formula:

$$V = \frac{nsdl}{Q_{fl}}$$

**WHERE:**

$d$  = depth of contact area between flange and web, in inches (mm).

$I$  = total moment of inertia, in inches to the fourth power (mm<sup>4</sup>), of all parallel grain material in the web and flanges regardless of butt joint. Stiffeners or web splice plates shall be disregarded.

$n$  = number of contact surfaces between web and flange.

$Q_{fl}$  = statical moment about the neutral axis, in inches to the third power (mm<sup>3</sup>), of all parallel grain material in the upper (or lower) flanges, regardless of butt joints.

$s$  = one half of the allowable plywood rolling shear stress, in pounds per square inch (N/mm<sup>2</sup>).

$V$  = allowable total shear on the section, in pounds (N). Loads may be disregarded that are located within a distance from the support equal to the beam depth.

**2349.4.4 Lateral stability.** The compression edges of the beam shall be positively restrained from lateral buckling, as by fastening to structural panel sheathing, framing spaced no further than 24 inches (610 mm) on center, and/or by ceiling material.

**2349.4.5 Connections.** Bolts, lag screws or other similar large-diameter connectors shall not be used in web or flange tension areas where bending stresses exceed the allowable values set forth in Table 23-I-B.

**2349.5 Materials.**

**2349.5.1 Plywood.** Plywood shall be as required in Section 2348.2.1. Plywood pieces cut 4<sup>1</sup>/<sub>2</sub> inches (114 mm) or less in width for flanges shall be visually inspected after cutting for size of knots. Pieces containing knots in face or back plies larger than two thirds of the flange width shall not be used in fabricating flanges for all-plywood beams.

**2349.5.2 Glue.** Glue shall be as specified in Section 2348.2.3.

**2349.5.3 Staples.** Staples shall be 16 gage by <sup>7</sup>/<sub>16</sub>-inch (1.6 mm by 11 mm) crown, made from galvanized steel wire. Staple length shall be <sup>1</sup>/<sub>8</sub> inch (3.2 mm) less than the total thickness of materials joined.

**2349.6 Fabrication.**

**2349.6.1 General.** Plywood beams shall be fabricated with glue and staples. Plywood face grain for webs, flanges, web splice plates and stiffeners shall be oriented parallel to the span (i.e., horizontally).

**2349.6.2 Web and flange end joints.** End joints in plywood webs and flanges shall be located as specified in the design. Joints in any web or flange lamination shall be spaced at least 24 inches (610 mm) from the nearest joint in any other lamination. In single-web beams, joints in webs shall be located at least 24 inches (610 mm) from any end or interior support.

Butt joints at ends of plywood web or flange pieces shall be trimmed square and tightly butted [maximum gap  $\frac{1}{32}$  inch (0.8 mm)].

**2349.6.3 Adhesive application.** Adhesive shall be spread uniformly over the full contact area of mating web and/or flange surfaces.

If web or flange laminations are glued under pressure, such pressure shall be applied by clamping or other mechanical means. Pressure shall be sufficient to provide adequate contact and ensure good glue bonds [100 to 150 psi (689 to 1034 kPa) is suggested, unless otherwise specified by the adhesive manufacturer]. Movement of the members shall be prevented until the adhesive develops sufficient handling strength as recommended by the adhesive manufacturer.

In any case, it shall be the responsibility of the fabricator to produce a glue bond which meets or exceeds applicable specifications.

**2349.6.4 Staple installation.** Staples shall be installed with their crowns parallel to the plywood face-grain direction. Staple spacing shall be as shown in Figure 23-IV-1.

Installation of staples may start at any point but shall progress to the end or ends of each piece. Pressure may be needed during stapling to flatten webs and flanges to ensure uniform contact between mating glued surfaces.

**2349.6.5 Web splices.** Splices at butt joints in webs shall be as specified in the design. Butt joints shall be spliced with a plywood plate centered over the joint. The splice plate shall be glued over its full contact area and stapled to the web in accordance with Figure 23-IV-1. The plate shall extend to at least  $\frac{1}{4}$  inch (6.4 mm) of each flange (if applicable); shall be equal in thickness to the web; shall be of a length as specified in the design or in Table 23-IV-B; and shall have its face-grain direction parallel with that of the web. In multiple-layer webs, the splice plate shall be directly glued to the web containing the butt joint.

**2349.6.6 Web stiffeners.** Stiffeners for single-layer webs shall be located as shown in the design, but in any case they shall be placed at end supports and at interior concentrated-load points.

The stiffeners shall consist of a plywood plate glued over its full contact area and stapled to the web in accordance with Figure 23-IV-1. The plate shall extend to at least  $\frac{1}{4}$  inch (6.4 mm) of each flange (if applicable); shall be at least equal in thickness to the web; shall be of a length as specified in the design, but in no case less than 10 inches (254 mm); and shall have its face-grain direction parallel with that of the web. The end or ends of the stiffener shall extend at least 6 inches (152 mm) beyond the edges of the support at the end and any interior supports.

Single-layer webs shall be reinforced at cutouts with a plywood web stiffener.

**2349.7 Identification.** Each member shall be identified as specified in Section 2348.4.

**2349.8 Test Samples.** Test samples shall be as specified in Section 2348.5.

**2349.9 Testing of Glued Joints.** Plywood splice butt joints shall be tested as specified in Section 2348.6.2.

**TABLE 23-IV-A—BASIC SPACING**

PLYWOOD THICKNESS (Inches)	PLYWOOD FINISH	BASIC SPACING "b" (Inches)	
		× 25.4 for mm	
		Face Grain Parallel to Longitudinal Members	Face Grain Perpendicular to Longitudinal Members
× 25.4 for mm			
1/4	Sanded	10.3	11.6
5/16	Rough	11.9	16.8
3/8	Rough (3-ply)	14.2	20.1
3/8	Sanded (3-ply)	16.4	16.4
3/8	Sanded (5-ply)	18.1	20.2
1/2	Rough and sanded (5-ply)	23.2	28.5
5/8	Rough and sanded (5-ply)	29.1	35.6
3/4	Rough and sanded (5-ply)	38.2	38.2
7/8	Sanded (7-ply)	41.6	48.1
1	Rough (7-ply)	45.5	58.9
1	Sanded (7-ply)	54.5	47.9

**TABLE 23-IV-B—LENGTH OF SPLICE PLATES**

THICKNESS OF SKIN (Inches)	LENGTH OF SPLICE PLATE (Inches)
× 25.4 for mm	
1/4	6
5/16	8
3/8 (sanded)	10
3/8 (unsanded)	12
1/2	14
5/8	16
3/4	16

**TABLE 23-IV-C—ALLOWABLE PLYWOOD TENSION STRESS FOR BUTT JOINT SPLICE<sup>1</sup>**

PLYWOOD THICKNESS (Inches)	ALL STRUCT. I GRADES	GROUP 1	GROUP 2 AND GROUP 3	GROUP 4
× 25.4 for mm	× 0.00689 for N/mm <sup>2</sup>			
1/4 5/16 3/8 sanded 3/8 unsanded	1,200	960	800	720
1/2	1,200	800	760	720
5/8 and 3/4	960	640	600	560

<sup>1</sup>These values are based upon stress acting parallel to the face grain and must be reduced in accordance with Table 23-I-B for stresses perpendicular or at 45 degrees to face grain. In addition, stresses are based upon a ratio of width of splice plate to the width of the stressed skin of 80 percent. Where other ratios are used, the allowable stress shall be adjusted accordingly. For applicable species groups for unsanded panels, refer to Footnote 1 of Table 23-I-B.

TABLE 23-IV-D—BRACING FOR DEEP NARROW BEAM

$\frac{l_x}{l_y}$	TYPE OF BRACING REQUIRED
Not more than 5	None required
More than 5 to not more than 10	Ends held in position at bottom flanges at supports
More than 10 to not more than 20	Ends held in position at top and bottom flanges at supports
More than 20 to not more than 30	Top or bottom flange continuously supported in accordance with Section 2346.3.1.3
More than 30 to not more than 40	Beam restrained by bridging or other bracing at not more than 8 feet (2438 mm) on center
More than 40	Bridging at 8 feet (2438 mm) on center and compression flanges continuously supported in accordance with Section 2346.3.1.3

TABLE 23-IV-E—AREA REDUCTION FACTORS

BUTT JOINT SPACING T = LAMINATION THICKNESS	PERCENT OF GROSS AREA OF ADJACENT LAMINATION EFFECTIVE
30T	90
20T	80
10T	60
Less than 10T	0

TABLE 23-IV-F—WEB STIFFENER SPACING

PLYWOOD WEB THICKNESS (inches)	CLEAR DISTANCE BETWEEN FLANGES (inches)					
	10	20	30	40	50	60 or More
	× 25.4 for mm					
$\frac{3}{8}$	15	15	15	15	15	15
$\frac{1}{2}$	27	22	22	22	22	22
$\frac{5}{8}$	48	29	28	28	28	28
$\frac{3}{4}$	48	38	35	34	34	34
$\frac{7}{8}$	48	48	41	39	39	39
1	48	48	48	48	46	45
$1\frac{3}{16}$	48	48	48	48	48	48

TABLE 23-IV-G—DRY SHEAR STRENGTH STRESS REQUIREMENTS<sup>1</sup>

GRAIN ORIENTATION OF LUMBER OR PLYWOOD WITH RESPECT TO ADJACENT PLY OR LUMBER LAMINATION	AVERAGE SHEAR STRESS (pounds per square inch)
	> 0.00689 for N/mm <sup>2</sup>
(Douglas Fir and Southern Pine)	
Parallel	650
45°	500
Perpendicular	250
(Other Species)	
Parallel	520
45°	400
Perpendicular	200

<sup>1</sup>The minimum shear test value shall not be less than twice the normal allowable rolling shear value.

**TABLE 23-IV-H—DRY TENSION STRESS**

AVERAGE TENSION STRESS (pounds per square inch)	MINIMUM TENSION STRESS FOR AT LEAST 80 PERCENT OF SPECIMENS (pounds per square inch)
× 0.00689 for N/mm <sup>2</sup>	
[Douglas Fir (Coast type) and Southern Pine]	
7,000	6,000
(Other Species)	
6,000	5,000

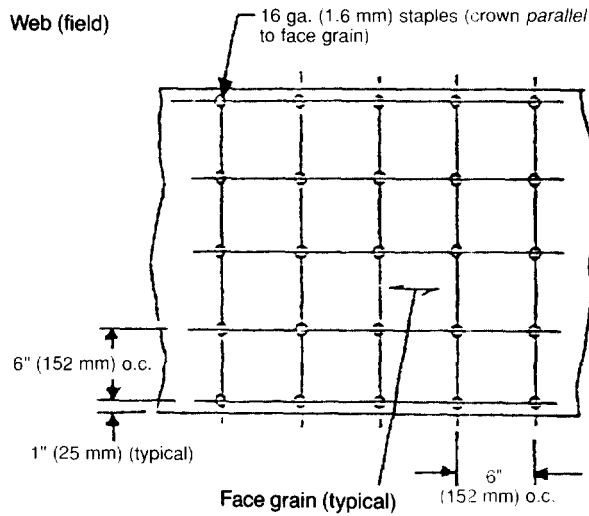

**FIGURE 23-IV-1—STAPLE SPACING FOR PLYWOOD WEBS, FLANGES, SPLICE PLATES AND STIFFENERS**

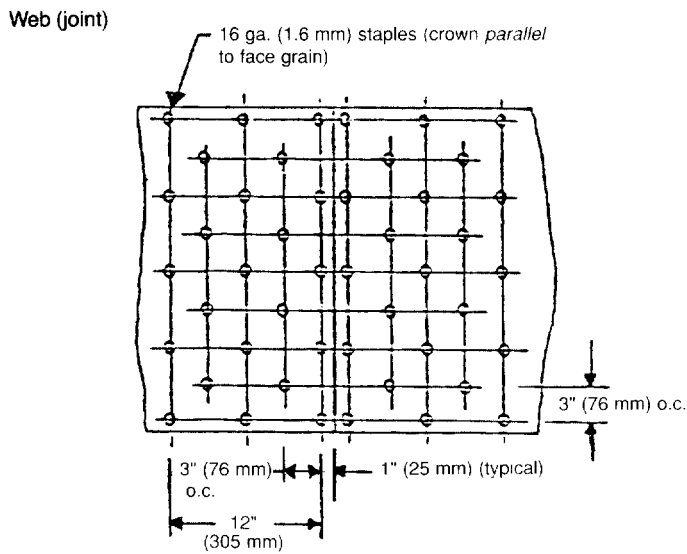
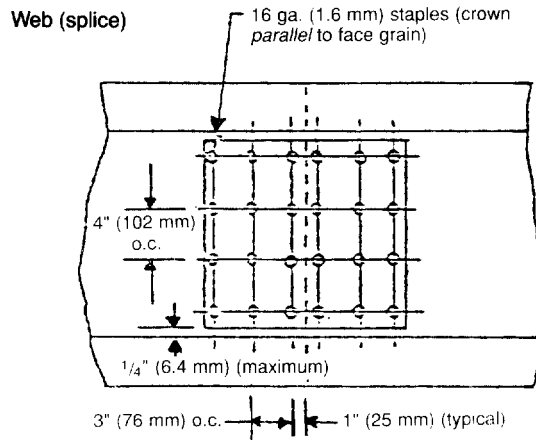

FIGURE 23-IV-1— (Continued)

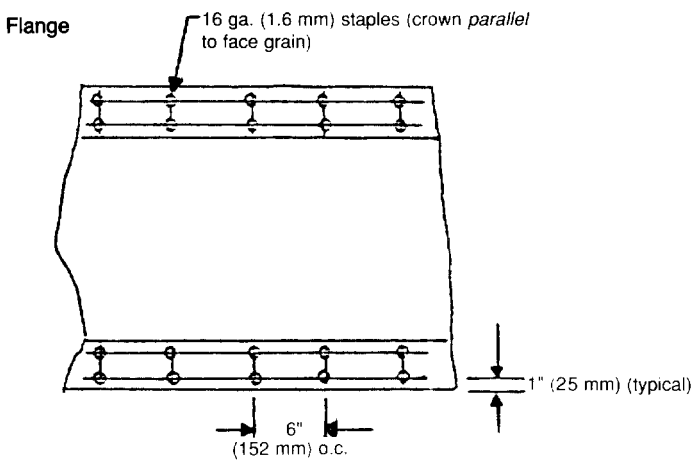
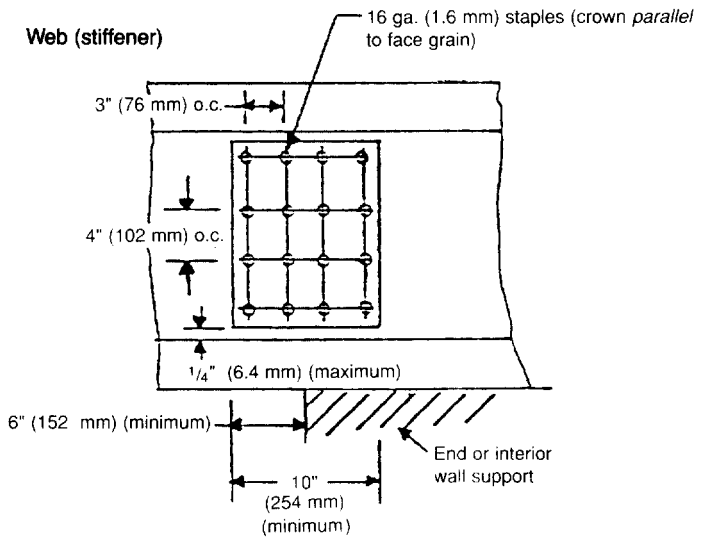

FIGURE 23-IV-1—(Continued)

## Division V—DESIGN STANDARD FOR SPAN TABLES FOR JOISTS AND RAFTERS

### SECTION 2350 — SCOPE

This standard covers the loading (DL and LL) and deflection criteria used to establish the allowable spans in Tables 23-I-V-J-1 through 23-I-V-R-12 and the tables of this division. The tables in this standard are intended for light-frame construction.

### SECTION 2351 — DESIGN CRITERIA FOR JOISTS AND RAFTERS

The allowable spans of tables of this standard and Tables 23-I-V-J-1 through 23-I-V-R-12 of Division I are calculated on the basis of a series of modulus of elasticity ( $E$ ), and fiber stress ( $F_b$ ) values. The range of values in the tables provides allowable spans for all species and grades of nominal 2-inch lumber customarily used in construction. The allowable span is the clear distance between supports. For sloping rafters the span is measured along the horizontal projection.

### SECTION 2352 — LUMBER STRESSES

The use of the span tables requires reference to the list of single or repetitive member bending stress values ( $F_b$ ) and modulus of elasticity values ( $E$ ) from Tables 23-I-X-1 and 23-I-X-2 of Division I.

### SECTION 2353 — MOISTURE CONTENT

Tabulated spans are calculated on the basis of the dry sizes and are also applicable to the corresponding green sizes. The spans in these tables are intended for use in covered structures or where moisture content in use does not exceed 19 percent.

### SECTION 2354 — LUMBER SIZE

Tabulated spans apply to surfaced (S4S) lumber having dimensions which conform to U.B.C. Standard 23-1.

### SECTION 2355 — SPAN TABLES FOR JOISTS AND RAFTERS

The following tables are based on the design criteria set forth in each table and of this standard.

**TABLE 23-V-J-1—FLOOR JOISTS WITH L/360 DEFLECTION LIMITS**

The allowable bending stress ( $F_b$ ) and modulus of elasticity ( $E$ ) used in this table shall be from Tables 23-I-X-1 and 23-I-X-2 only.

<b>DESIGN CRITERIA:</b>																		
Deflection — For 50 psf (2.4 kN/m <sup>2</sup> ) live load. Limited to span in inches (mm) divided by 360.																		
Strength — Live load of 50 psf (2.4 kN/m <sup>2</sup> ) plus dead load of 10 psf (0.48 kN/m <sup>2</sup> ) determines the required bending design value.																		
Joist Size (in)	Spacing (in)	Modulus of Elasticity, $E$ , in 1,000,000 psi ( $\times 0.00689$ for N/mm <sup>2</sup> )																
$\times 25.4$ for mm		0.8	0.9	1.0	1.1	1.2	1.3	1.4	1.5	1.6	1.7	1.8	1.9	2.0	2.1	2.2	2.3	2.4
2 $\times$ 6	12.0	7-11	8-3	8-6	8-9	9-1	9-3	9-6	9-9	9-11	10-2	10-4	10-6	10-9	10-11	11-1	11-3	11-5
	16.0	7-2	7-6	7-9	8-0	8-3	8-5	8-8	8-10	9-1	9-3	9-5	9-7	9-9	9-11	10-1	10-2	10-4
	19.2	6-9	7-0	7-3	7-6	7-9	7-11	8-2	8-4	8-6	8-8	8-10	9-0	9-2	9-4	9-6	9-7	9-9
	24.0	6-3	6-6	6-9	7-0	7-2	7-4	7-7	7-9	7-11	8-1	8-3	8-4	8-6	8-8	8-9	8-11	9-1
2 $\times$ 8	12.0	10-5	10-10	11-3	11-7	11-11	12-3	12-7	12-10	13-1	13-5	13-8	13-11	14-2	14-4	14-7	14-10	15-0
	16.0	9-6	9-10	10-2	10-6	10-10	11-1	11-5	11-8	11-11	12-2	12-5	12-7	12-10	13-1	13-3	13-5	13-8
	19.2	8-11	9-3	9-7	9-11	10-2	10-6	10-9	11-0	11-3	11-5	11-8	11-11	12-1	12-3	12-6	12-8	12-10
	24.0	8-3	8-7	8-11	9-2	9-6	9-9	10-0	10-2	10-5	10-8	10-10	11-0	11-3	11-5	11-7	11-9	11-11
2 $\times$ 10	12.0	13-3	13-10	14-4	14-9	15-2	15-7	16-0	16-5	16-9	17-1	17-5	17-9	18-0	18-4	18-7	18-11	19-2
	16.0	12-1	12-7	13-0	13-5	13-10	14-2	14-7	14-11	15-2	15-6	15-10	16-1	16-5	16-8	16-11	17-2	17-5
	19.2	11-4	11-10	12-3	12-8	13-0	13-4	13-8	14-0	14-4	14-7	14-11	15-2	15-5	15-8	15-11	16-2	16-5
	24.0	10-7	11-0	11-4	11-9	12-1	12-5	12-8	13-0	13-3	13-7	13-10	14-1	14-4	14-7	14-9	15-0	15-2
2 $\times$ 12	12.0	16-2	16-10	17-5	18-0	18-6	19-0	19-6	19-11	20-4	20-9	21-2	21-7	21-11	22-3	22-8	23-0	23-4
	16.0	14-8	15-3	15-10	16-4	16-10	17-3	17-8	18-1	18-6	18-10	19-3	19-7	19-11	20-3	20-7	20-10	21-2
	19.2	13-10	14-4	14-11	15-4	15-10	16-3	16-8	17-0	17-5	17-9	18-1	18-5	18-9	19-1	19-4	19-8	19-11
	24.0	12-10	13-4	13-10	14-3	14-8	15-1	15-5	15-10	16-2	16-6	16-10	17-1	17-5	17-8	18-0	18-3	18-6
$F_b$	12.0	743	803	862	918	973	1,026	1,078	1,129	1,179	1,228	1,275	1,322	1,368	1,413	1,458	1,502	1,545
	16.0	817	884	949	1,011	1,071	1,130	1,187	1,243	1,298	1,351	1,404	1,455	1,506	1,555	1,604	1,653	1,700
	19.2	869	940	1,008	1,074	1,138	1,201	1,261	1,321	1,379	1,436	1,491	1,546	1,600	1,653	1,705	1,756	1,807
	24.0	936	1,012	1,086	1,157	1,226	1,293	1,359	1,423	1,485	1,547	1,607	1,666	1,724	1,781	1,837	1,892	1,946

**NOTE:** The required bending design value,  $F_b$ , in pounds per square inch (N/mm<sup>2</sup>) is shown at the bottom of this table and is applicable to all lumber sizes shown. Spans are shown in feet-inches (1 foot = 304.8 mm, 1 inch = 25.4 mm) and are limited to 26 feet (7925 mm) and less. Check sources of supply for availability of lumber in lengths greater than 20 feet (6096 mm).

TABLE 23-V-J-2—FLOOR JOISTS WITH L/360 DEFLECTION LIMITS

The allowable bending stress ( $F_b$ ) and modulus of elasticity ( $E$ ) used in this table shall be from Tables 23-I-X-1 and 23-I-X-2 only.

DESIGN CRITERIA:																		
Deflection — For 60 psf (2.87 kN/m <sup>2</sup> ) live load. Limited to span in inches (mm) divided by 360.																		
Strength — Live load of 60 psf (2.87 kN/m <sup>2</sup> ) plus dead load of 10 psf (0.48 kN/m <sup>2</sup> ) determines the required bending design value.																		
Joist Size (in)	Spacing (in)	Modulus of Elasticity, $E$ , in 1,000,000 psi ( $\times 0.00689$ for N/mm <sup>2</sup> )																
		$\times 25.4$ for mm	0.8	0.9	1.0	1.1	1.2	1.3	1.4	1.5	1.6	1.7	1.8	1.9	2.0	2.1	2.2	2.3
2 $\times$ 6	12.0	7-5	7-9	8-0	8-3	8-6	8-9	8-11	9-2	9-4	9-7	9-9	9-11	10-1	10-3	10-5	10-7	10-9
	16.0	6-9	7-0	7-3	7-6	7-9	7-11	8-2	8-4	8-6	8-8	8-10	9-0	9-2	9-4	9-6	9-7	9-9
	19.2	6-4	6-7	6-10	7-1	7-3	7-6	7-8	7-10	8-0	8-2	8-4	8-6	8-8	8-9	8-11	9-0	9-2
	24.0	5-11	6-2	6-4	6-7	6-9	6-11	7-1	7-3	7-5	7-7	7-9	7-10	8-0	8-2	8-3	8-5	8-6
2 $\times$ 8	12.0	9-10	10-2	10-7	10-11	11-3	11-6	11-10	12-1	12-4	12-7	12-10	13-1	13-4	13-6	13-9	13-11	14-2
	16.0	8-11	9-3	9-7	9-11	10-2	10-6	10-9	11-0	11-3	11-5	11-8	11-11	12-1	12-3	12-6	12-8	12-10
	19.2	8-5	8-9	9-0	9-4	9-7	9-10	10-1	10-4	10-7	10-9	11-0	11-2	11-4	11-7	11-9	11-11	12-1
	24.0	7-9	8-1	8-5	8-8	8-11	9-2	9-4	9-7	9-10	10-0	10-2	10-5	10-7	10-9	10-11	11-1	11-3
2 $\times$ 10	12.0	12-6	13-0	13-6	13-11	14-4	14-8	15-1	15-5	15-9	16-1	16-5	16-8	17-0	17-3	17-6	17-9	18-0
	16.0	11-4	11-10	12-3	12-8	13-0	13-4	13-8	14-0	14-4	14-7	14-11	15-2	15-5	15-8	15-11	16-2	16-5
	19.2	10-8	11-1	11-6	11-11	12-3	12-7	12-11	13-2	13-6	13-9	14-0	14-3	14-6	14-9	15-0	15-2	15-5
	24.0	9-11	10-4	10-8	11-0	11-4	11-8	11-11	12-3	12-6	12-9	13-0	13-3	13-6	13-8	13-11	14-1	14-4
2 $\times$ 12	12.0	15-2	15-10	16-5	16-11	17-5	17-11	18-4	18-9	19-2	19-7	19-11	20-3	20-8	21-0	21-4	21-7	21-11
	16.0	13-10	14-4	14-11	15-4	15-10	16-3	16-8	17-0	17-5	17-9	18-1	18-5	18-9	19-1	19-4	19-8	19-11
	19.2	13-0	13-6	14-0	14-5	14-11	15-3	15-8	16-0	16-5	16-9	17-0	17-4	17-8	17-11	18-3	18-6	18-9
	24.0	12-1	12-7	13-0	13-5	13-10	14-2	14-7	14-11	15-2	15-6	15-10	16-1	16-5	16-8	16-11	17-2	17-5
$F_b$	12.0	767	830	890	949	1,005	1,061	1,114	1,167	1,218	1,268	1,317	1,366	1,413	1,460	1,506	1,551	1,596
	16.0	844	913	980	1,044	1,107	1,167	1,226	1,284	1,341	1,396	1,450	1,503	1,556	1,607	1,658	1,707	1,757
	19.2	897	971	1,041	1,110	1,176	1,240	1,303	1,365	1,425	1,483	1,541	1,597	1,653	1,708	1,761	1,814	1,867
	24.0	967	1,046	1,122	1,195	1,267	1,336	1,404	1,470	1,535	1,598	1,660	1,721	1,781	1,840	1,897	1,955	2,011

NOTE: The required bending design value,  $F_b$ , in pounds per square inch (N/mm<sup>2</sup>) is shown at the bottom of this table and is applicable to all lumber sizes shown. Spans are shown in feet-inches (1 foot = 304.8 mm, 1 inch = 25.4 mm) and are limited to 26 feet (7925 mm) and less. Check sources of supply for availability of lumber in lengths greater than 20 feet (6096 mm).

**TABLE 23-V-J-3—FLOOR JOISTS WITH L/360 DEFLECTION LIMITS**

The allowable bending stress ( $F_b$ ) and modulus of elasticity ( $E$ ) used in this table shall be from Tables 23-I-X-1 and 23-I-X-2 only.

<b>DESIGN CRITERIA:</b>																		
Deflection — For 50 psf (2.4 kN/m <sup>2</sup> ) live load.																		
Limited to span in inches (mm) divided by 360.																		
Strength — Live load of 50 psf (2.4 kN/m <sup>2</sup> ) plus dead load of 20 psf (0.96 kN/m <sup>2</sup> ) determines the required bending design value.																		
Joist Size (in)	Spacing (in)	Modulus of Elasticity, $E$ , in 1,000,000 psi ( $\times 0.00689$ for N/mm <sup>2</sup> )																
		$\times 25.4$ for mm	0.8	0.9	1.0	1.1	1.2	1.3	1.4	1.5	1.6	1.7	1.8	1.9	2.0	2.1	2.2	2.3
2 $\times$ 6	12.0	7-11	8-3	8-6	8-9	9-1	9-3	9-6	9-9	9-11	10-2	10-4	10-6	10-9	10-11	11-1	11-3	11-5
	16.0	7-2	7-6	7-9	8-0	8-3	8-5	8-8	8-10	9-1	9-3	9-5	9-7	9-9	9-11	10-1	10-2	10-4
	19.2	6-9	7-0	7-3	7-6	7-9	7-11	8-2	8-4	8-6	8-8	8-10	9-0	9-2	9-4	9-6	9-7	9-9
	24.0	6-3	6-6	6-9	7-0	7-2	7-4	7-7	7-9	7-11	8-1	8-3	8-4	8-6	8-8	8-9	8-11	9-1
2 $\times$ 8	12.0	10-5	10-10	11-3	11-7	11-11	12-3	12-7	12-10	13-1	13-5	13-8	13-11	14-2	14-4	14-7	14-10	15-0
	16.0	9-6	9-10	10-2	10-6	10-10	11-1	11-5	11-8	11-11	12-2	12-5	12-7	12-10	13-1	13-3	13-5	13-8
	19.2	8-11	9-3	9-7	9-11	10-2	10-6	10-9	11-0	11-3	11-5	11-8	11-11	12-1	12-3	12-6	12-8	12-10
	24.0	8-3	8-7	8-11	9-2	9-6	9-9	10-0	10-2	10-5	10-8	10-10	11-0	11-3	11-5	11-7	11-9	11-11
2 $\times$ 10	12.0	13-3	13-10	14-4	14-9	15-2	15-7	16-0	16-5	16-9	17-1	17-5	17-9	18-0	18-4	18-7	18-11	19-2
	16.0	12-1	12-7	13-0	13-5	13-10	14-2	14-7	14-11	15-2	15-6	15-10	16-1	16-5	16-8	16-11	17-2	17-5
	19.2	11-4	11-10	12-3	12-8	13-0	13-4	13-8	14-0	14-4	14-7	14-11	15-2	15-5	15-8	15-11	16-2	16-5
	24.0	10-7	11-0	11-4	11-9	12-1	12-5	12-8	13-0	13-3	13-7	13-10	14-1	14-4	14-7	14-9	15-0	15-2
2 $\times$ 12	12.0	16-2	16-10	17-5	18-0	18-6	19-0	19-6	19-11	20-4	20-9	21-2	21-7	21-11	22-3	22-8	23-0	23-4
	16.0	14-8	15-3	15-10	16-4	16-10	17-3	17-8	18-1	18-6	18-10	19-3	19-7	19-11	20-3	20-7	20-10	21-2
	19.2	13-10	14-4	14-11	15-4	15-10	16-3	16-8	17-0	17-5	17-9	18-1	18-5	18-9	19-1	19-4	19-8	19-11
	24.0	12-10	13-4	13-10	14-3	14-8	15-1	15-5	15-10	16-2	16-6	16-10	17-1	17-5	17-8	18-0	18-3	18-6
$F_b$	12.0	866	937	1,005	1,071	1,135	1,198	1,258	1,317	1,375	1,432	1,488	1,542	1,596	1,649	1,701	1,752	1,802
	16.0	954	1,032	1,107	1,179	1,250	1,318	1,385	1,450	1,514	1,576	1,637	1,698	1,757	1,815	1,872	1,928	1,984
	19.2	1,013	1,096	1,176	1,253	1,328	1,401	1,472	1,541	1,609	1,675	1,740	1,804	1,867	1,928	1,989	2,049	2,108
	24.0	1,092	1,181	1,267	1,350	1,430	1,509	1,585	1,660	1,733	1,804	1,874	1,943	2,011	2,077	2,143	2,207	2,271

**NOTE:** The required bending design value,  $F_b$ , in pounds per square inch (N/mm<sup>2</sup>) is shown at the bottom of this table and is applicable to all lumber sizes shown. Spans are shown in feet-inches (1 foot = 304.8 mm, 1 inch = 25.4 mm) and are limited to 26 feet (7925 mm) and less. Check sources of supply for availability of lumber in lengths greater than 20 feet (6096 mm).

TABLE 23-V-J-4—FLOOR JOISTS WITH L/360 DEFLECTION LIMITS

The allowable bending stress ( $F_b$ ) and modulus of elasticity ( $E$ ) used in this table shall be from Tables 23-I-X-1 and 23-I-X-2 only.

DESIGN CRITERIA: Deflection — For 60 psf (2.87 kN/m <sup>2</sup> ) live load. Limited to span in inches (mm) divided by 360. Strength — Live load of 60 psf (2.87 kN/m <sup>2</sup> ) plus dead load of 20 psf (0.96 kN/m <sup>2</sup> ) determines the required bending design value.																		
Joist Size (in)	Spacing (in)	Modulus of Elasticity, $E$ , in 1,000,000 psi ( $\times 0.00689$ for N/mm <sup>2</sup> )																
$\times 25.4$ for mm		0.8	0.9	1.0	1.1	1.2	1.3	1.4	1.5	1.6	1.7	1.8	1.9	2.0	2.1	2.2	2.3	2.4
2 $\times$ 6	12.0	7- 5	7- 9	8- 0	8- 3	8- 6	8- 9	8-11	9- 2	9- 4	9- 7	9- 9	9-11	10- 1	10- 3	10- 5	10- 7	10- 9
	16.0	6- 9	7- 0	7- 3	7- 6	7- 9	7-11	8- 2	8- 4	8- 6	8- 8	8-10	9- 0	9- 2	9- 4	9- 6	9- 7	9- 9
	19.2	6- 4	6- 7	6-10	7- 1	7- 3	7- 6	7- 8	7-10	8- 0	8- 2	8- 4	8- 6	8- 8	8- 9	8-11	9- 0	9- 2
	24.0	5-11	6- 2	6- 4	6- 7	6- 9	6-11	7- 1	7- 3	7- 5	7- 7	7- 9	7-10	8- 0	8- 2	8- 3	8- 5	8- 6
2 $\times$ 8	12.0	9-10	10- 2	10- 7	10-11	11- 3	11- 6	11-10	12- 1	12- 4	12- 7	12-10	13- 1	13- 4	13- 6	13- 9	13-11	14- 2
	16.0	8-11	9- 3	9- 7	9-11	10- 2	10- 6	10- 9	11- 0	11- 3	11- 5	11- 8	11-11	12- 1	12- 3	12- 6	12- 8	12-10
	19.2	8- 5	8- 9	9- 0	9- 4	9- 7	9-10	10- 1	10- 4	10- 7	10- 9	11- 0	11- 2	11- 4	11- 7	11- 9	11-11	12- 1
	24.0	7- 9	8- 1	8- 5	8- 8	8-11	9- 2	9- 4	9- 7	9-10	10- 0	10- 2	10- 5	10- 7	10- 9	10-11	11- 1	11- 3
2 $\times$ 10	12.0	12- 6	13- 0	13- 6	13-11	14- 4	14- 8	15- 1	15- 5	15- 9	16- 1	16- 5	16- 8	17- 0	17- 3	17- 6	17- 9	18- 0
	16.0	11- 4	11-10	12- 3	12- 8	13- 0	13- 4	13- 8	14- 0	14- 4	14- 7	14-11	15- 2	15- 5	15- 8	15-11	16- 2	16- 5
	19.2	10- 8	11- 1	11- 6	11-11	12- 3	12- 7	12-11	13- 2	13- 6	13- 9	14- 0	14- 3	14- 6	14- 9	15- 0	15- 2	15- 5
	24.0	9-11	10- 4	10- 8	11- 0	11- 4	11- 8	11-11	12- 3	12- 6	12- 9	13- 0	13- 3	13- 6	13- 8	13-11	14- 1	14- 4
2 $\times$ 12	12.0	15- 2	15-10	16- 5	16-11	17- 5	17-11	18- 4	18- 9	19- 2	19- 7	19-11	20- 3	20- 8	21- 0	21- 4	21- 7	21-11
	16.0	13-10	14- 4	14-11	15- 4	15-10	16- 3	16- 8	17- 0	17- 5	17- 9	18- 1	18- 5	18- 9	19- 1	19- 4	19- 8	19-11
	19.2	13- 0	13- 6	14- 0	14- 5	14-11	15- 3	15- 8	16- 0	16- 5	16- 9	17- 0	17- 4	17- 8	17-11	18- 3	18- 6	18- 9
	24.0	12- 1	12- 7	13- 0	13- 5	13-10	14- 2	14- 7	14-11	15- 2	15- 6	15-10	16- 1	16- 5	16- 8	16-11	17- 2	17- 5
$F_b$	12.0	877	949	1,018	1,084	1,149	1,212	1,273	1,333	1,392	1,449	1,506	1,561	1,615	1,669	1,721	1,773	1,824
	16.0	965	1,044	1,120	1,193	1,265	1,334	1,402	1,468	1,532	1,595	1,657	1,718	1,778	1,837	1,894	1,951	2,008
	19.2	1,026	1,109	1,190	1,268	1,344	1,418	1,489	1,559	1,628	1,695	1,761	1,826	1,889	1,952	2,013	2,074	2,133
	24.0	1,105	1,195	1,282	1,366	1,448	1,527	1,604	1,680	1,754	1,826	1,897	1,967	2,035	2,102	2,169	2,234	2,298

**NOTE:** The required bending design value,  $F_b$ , in pounds per square inch (N/mm<sup>2</sup>) is shown at the bottom of this table and is applicable to all lumber sizes shown. Spans are shown in feet-inches (1 foot = 304.8 mm, 1 inch = 25.4 mm) and are limited to 26 feet (7925 mm) and less. Check sources of supply for availability of lumber in lengths greater than 20 feet (6096 mm).

**TABLE 23-V-R-1—RAFTERS WITH L/240 DEFLECTION LIMITS**

The allowable bending stress ( $F_b$ ) and modulus of elasticity ( $E$ ) used in this table shall be from Tables 23-I-X-1 and 23-I-X-2 only.

DESIGN CRITERIA: Strength — Live load of 40 psf (1.92 kN/m <sup>2</sup> ) plus dead load of 10 psf (0.48 kN/m <sup>2</sup> ) determines the required bending design value. Deflection — For 40 psf live (1.02 kN/m <sup>2</sup> ) load. Limited to span in inches (mm) divided by 240.																									
Rafter Size (in)	Spacing (in)	Bending Design Value, $F_b$ (psi) ( $\times 0.00689$ for N/mm <sup>2</sup> )																							
	$\times 25.4$ for mm	300	400	500	600	700	800	900	1000	1100	1200	1300	1400	1500	1600	1700	1800	1900	2000	2100	2200	2300	2400		
2 $\times$ 6	12.0	5-8	6-4	7-1	7-8	8-5	8-8	9-6	10-6	10-6	11-0	11-5	11-11	12-4	12-8	13-1	13-6	13-10	14-2						
	18.0	4-9	5-6	6-2	6-9	7-3	7-9	8-3	8-8	9-1	9-8	9-11	10-3	10-8	11-0	11-4	11-8	12-0	12-4	12-7	12-11				
	19.2	4-4	5-0	5-7	6-2	6-8	7-1	7-8	7-11	8-4	8-8	9-1	9-5	9-9	10-0	10-4	10-8	10-11	11-3	11-6	11-9	12-0	12-4		
	24.0	3-11	4-6	5-0	5-6	5-11	6-4	6-9	7-1	7-5	7-9	8-1	8-5	8-8	9-0	9-3	9-6	9-9	10-0	10-3	10-6	10-9	11-0		
2 $\times$ 8	12.0	7-3	8-4	9-4	10-3	11-1	11-10	12-7	13-3	13-11	14-6	15-1	15-8	16-3	16-8	17-3	17-8	18-3	18-9						
	18.0	6-3	7-3	8-1	8-11	9-7	10-3	10-10	11-6	12-0	12-7	13-1	13-7	14-0	14-6	14-11	15-5	15-10	16-3	16-7	17-0				
	19.2	5-8	6-7	7-5	8-1	8-9	9-4	9-11	10-6	11-0	11-6	11-11	12-5	12-10	13-3	13-8	14-0	14-5	14-10	15-2	15-6	15-10	16-3		
	24.0	5-2	5-11	6-7	7-3	7-10	8-4	8-11	9-4	9-10	10-3	10-8	11-1	11-6	11-10	12-2	12-7	12-11	13-3	13-7	13-11	14-2	14-6		
2 $\times$ 10	12.0	9-3	10-8	11-11	13-1	14-2	15-1	16-0	18-11	17-9	18-6	19-3	20-0	20-8	21-4	22-0	22-8	23-3	23-11						
	18.0	8-0	9-3	10-4	11-4	12-3	13-1	13-10	14-8	15-4	16-0	16-8	17-4	17-11	18-6	18-1	19-7	20-2	20-8	21-2	21-8				
	19.2	7-4	8-5	9-5	10-4	11-2	11-11	12-8	13-4	14-0	14-8	15-3	15-10	16-4	16-11	17-5	17-11	18-5	18-11	18-4	19-10	20-3	20-8		
	24.0	6-6	7-7	8-5	9-3	10-0	10-8	11-4	11-11	12-6	13-1	13-7	14-2	14-8	15-1	15-7	16-0	16-6	16-11	17-4	17-8	18-1	18-6		
2 $\times$ 12	12.0	11-3	13-0	14-6	15-11	17-2	18-4	19-8	20-8	21-7	22-6	23-5	24-4	25-2	26-0										
	18.0	9-9	11-3	12-7	13-9	14-11	15-11	16-10	17-9	18-8	19-6	20-3	21-1	21-9	22-6	23-2	23-10	24-6	25-2	25-9					
	19.2	8-11	10-3	11-6	12-7	13-7	14-8	15-5	16-3	17-0	17-9	18-6	19-3	19-11	20-6	21-2	21-9	22-5	23-0	23-6	24-1	24-8	25-2		
	24.0	7-11	8-2	10-3	11-3	12-2	13-0	13-8	14-6	15-3	15-11	16-7	17-2	17-9	18-4	18-11	19-6	20-0	20-6	21-1	21-7	22-0	22-6		
E	12.0	0.14	0.22	0.31	0.41	0.51	0.63	0.75	0.88	1.01	1.15	1.30	1.45	1.61	1.77	1.94	2.12	2.30	2.48						
	18.0	0.12	0.18	0.27	0.35	0.44	0.54	0.65	0.76	0.88	1.00	1.12	1.26	1.39	1.54	1.68	1.83	1.99	2.15	2.31	2.48				
	19.2	0.11	0.16	0.24	0.32	0.41	0.50	0.59	0.69	0.80	0.91	1.03	1.15	1.27	1.40	1.54	1.67	1.81	1.96	2.11	2.26	2.42	2.58		
	24.0	0.10	0.16	0.22	0.29	0.36	0.44	0.53	0.62	0.71	0.81	0.92	1.03	1.14	1.25	1.37	1.50	1.62	1.75	1.89	2.02	2.16	2.30		

NOTE: The required modulus of elasticity,  $E$ , in 1,000,000 pounds per square inch is shown at the bottom of this table, is limited to 2.6 million psi ( $17.92 \times 10^6$  kN/m<sup>2</sup>) and less, and is applicable to all lumber sizes shown. Spans are shown in feet-inches (1 foot = 304.8 mm, 1 inch = 25.4 mm) and are limited to 26 feet (7925 mm) and less.

**TABLE 23-V-R-2—RAFTERS WITH L/240 DEFLECTION LIMITS**

The allowable bending stress ( $F_b$ ) and modulus of elasticity ( $E$ ) used in this table shall be from Tables 23-I-X-1 and 23-I-X-2 only.

**DESIGN CRITERIA:**

Strength — Live load of 50 psf (2.40 kN/m<sup>2</sup>) plus dead load of 10 psf (0.48 kN/m<sup>2</sup>) determines the required bending design value.

Deflection — For 50 psf (2.4 kN/m<sup>2</sup>) live load.

Limited to span in inches (mm) divided by 240.

Rafter Size (in)	Spacing (in)	Bending Design Value, $F_b$ (psi) ( $\times 0.00689$ for N/mm <sup>2</sup> )																							
		$\times 25.4$ for mm	300	400	500	600	700	800	900	1000	1100	1200	1300	1400	1500	1600	1700	1800	1900	2000	2100	2200	2300	2400	
2 $\times$ 8	12.0	5-0	5-10	6-8	7-1	7-8	8-2	8-8	8-2	8-7	10-0	10-5	10-10	11-3	11-7	11-11	12-4	12-8	13-0	13-3					
	18.0	4-4	5-0	5-7	6-2	6-8	7-1	7-6	7-11	8-4	8-8	8-1	8-5	8-8	10-0	10-4	10-8	10-11	11-3	11-6	11-9	12-0			
	19.2	4-0	4-7	5-1	5-7	6-1	6-6	6-10	7-3	7-7	7-11	8-3	8-7	8-11	9-2	9-5	9-9	10-0	10-3	10-6	10-9	11-0	11-3		
	24.0	3-7	4-1	4-7	5-0	5-5	5-10	6-2	6-6	6-10	7-1	7-5	7-8	7-11	8-2	8-5	8-8	8-11	9-2	9-5	9-7	9-10	10-0		
2 $\times$ 8	12.0	8-7	7-8	8-7	9-4	10-1	10-10	11-6	12-1	12-8	13-3	13-8	14-4	14-10	15-3	15-9	16-3	16-8	17-1	17-6					
	18.0	5-9	6-7	7-5	8-1	8-9	9-4	9-11	10-6	11-0	11-6	11-11	12-5	12-10	13-3	13-8	14-0	14-5	14-10	15-2	15-6	15-10			
	19.2	5-3	6-0	6-8	7-5	8-0	8-7	9-1	9-7	10-0	10-6	10-11	11-4	11-8	12-1	12-5	12-10	13-2	13-6	13-10	14-2	14-6	14-10		
	24.0	4-8	5-5	6-0	6-7	7-2	7-8	8-1	8-7	8-8	9-4	9-9	10-1	10-6	10-10	11-2	11-8	11-9	12-1	12-5	12-8	12-11	13-3		
2 $\times$ 10	12.0	8-5	8-8	10-11	11-11	12-11	13-8	14-8	15-5	16-2	16-11	17-7	18-3	18-11	19-8	20-1	20-8	21-3	21-10	22-4					
	18.0	7-4	8-5	9-5	10-4	11-2	11-11	12-8	13-4	14-0	14-8	15-3	15-10	16-4	16-11	17-5	17-11	18-5	18-11	18-4	18-10	20-3			
	19.2	8-8	7-8	8-7	9-5	10-2	10-11	11-7	12-2	12-9	13-4	13-11	14-5	14-11	15-5	15-11	16-4	16-10	17-3	17-8	18-1	18-6	18-11		
	24.0	8-0	6-11	7-8	8-5	9-1	9-9	10-4	10-11	11-5	11-11	12-5	12-11	13-4	13-9	14-3	14-8	15-0	15-5	15-10	16-2	16-8	16-11		
2 $\times$ 12	12.0	10-3	11-10	13-3	14-8	15-8	16-9	17-9	18-9	19-8	20-6	21-5	22-2	23-0	23-9	24-5	25-2	25-10							
	18.0	8-11	10-3	11-6	12-7	13-7	14-6	15-5	16-3	17-0	17-9	18-8	18-3	19-11	20-8	21-2	21-8	22-5	23-0	23-8	24-1	24-8			
	19.2	8-1	9-4	10-6	11-6	12-5	13-3	14-1	14-10	15-7	16-3	16-11	17-6	18-2	18-9	19-4	19-11	20-5	21-0	21-6	22-0	22-6	23-0		
	24.0	7-3	8-5	9-4	10-3	11-1	11-10	12-7	13-3	13-11	14-6	15-1	15-8	16-3	16-9	17-3	17-9	18-3	18-8	19-3	19-8	20-1	20-6		
E	12.0	0.14	0.21	0.29	0.39	0.49	0.60	0.71	0.83	0.96	1.10	1.24	1.38	1.53	1.69	1.85	2.01	2.16	2.36	2.54					
	18.0	0.12	0.18	0.26	0.34	0.42	0.52	0.62	0.72	0.83	0.95	1.07	1.20	1.33	1.46	1.60	1.74	1.89	2.04	2.29	2.35	2.52			
	19.2	0.11	0.17	0.23	0.31	0.39	0.47	0.56	0.66	0.76	0.87	0.98	1.09	1.21	1.33	1.46	1.59	1.73	1.88	2.06	2.15	2.30	2.45		
	24.0	0.10	0.15	0.21	0.27	0.35	0.42	0.50	0.59	0.68	0.77	0.87	0.96	1.06	1.19	1.31	1.42	1.54	1.67	1.79	1.92	2.06	2.19		

**NOTE:** The required modulus of elasticity,  $E$ , in 1,000,000 pounds per square inch is shown at the bottom of this table, is limited to 2.6 million psi ( $17.92 \times 10^6$  kN/m<sup>2</sup>) and less, and is applicable to all lumber sizes shown. Spans are shown in feet-inches (1 foot = 304.8 mm, 1 inch = 25.4 mm) and are limited to 26 feet (7925 mm) and less.

**TABLE 23-V-R-3—RAFTERS WITH L/240 DEFLECTION LIMITS**

The allowable bending stress ( $F_b$ ) and modulus of elasticity ( $E$ ) used in this table shall be from Tables 23-I-X-1 and 23-I-X-2 only.

<b>DESIGN CRITERIA:</b>																												
Strength — Live load of 40 psf (1.92 kN/m <sup>2</sup> ) plus dead load of 15 psf (0.72 kN/m <sup>2</sup> ) determines the required bending design value.																												
Deflection — For 40 psf (1.92 kN/m <sup>2</sup> ) live load.																												
Limited to span in inches (mm) divided by 240.																												
Rafter Size (in)	Spacing (in)	Bending Design Value, $F_b$ (psi) ( $\times 0.00689$ for kN/m <sup>2</sup> )																										
		$\times 25.4$ for mm	300	400	500	600	700	800	900	1000	1100	1200	1300	1400	1500	1600	1700	1800	1900	2000	2100	2200	2300	2400	2500	2600	2700	
2 $\times$ 8	12.0	5-3	6-1	6-8	7-5	8-0	8-7	8-1	8-7	10-0	10-6	10-11	11-4	11-8	12-1	12-6	12-10	13-2	13-8	13-10	14-2							
	18.0	4-8	5-3	5-10	6-5	6-11	7-5	7-10	8-3	8-8	9-1	9-5	9-10	10-2	10-6	10-10	11-1	11-5	11-8	12-0	12-4	12-7	12-10					
	19.2	4-2	4-8	5-4	5-10	6-4	6-8	7-2	7-7	7-11	8-3	8-8	9-11	9-3	9-7	9-10	10-2	10-5	10-8	11-8	11-8	11-8	11-8	11-8	11-8	12-0	12-2	
	24.0	3-8	4-3	4-8	5-3	5-8	6-1	6-5	6-8	7-1	7-5	7-8	8-0	8-3	8-7	8-10	8-1	9-4	9-7	9-10	10-0	10-3	10-8	10-8	10-8	10-8	10-11	11-1
2 $\times$ 8	12.0	6-11	6-8	8-11	8-8	10-7	11-3	12-8	12-7	13-3	13-10	14-5	14-11	15-5	16-8	16-5	16-11	17-5	17-10	18-3	18-8							
	18.0	6-8	6-11	7-8	8-6	9-2	9-8	10-4	10-11	11-6	12-8	12-8	12-11	13-5	13-10	14-3	14-8	15-1	15-5	15-10	16-3	16-7	16-11					
	19.2	5-8	6-4	7-1	7-8	8-4	8-11	9-8	10-8	10-8	10-11	11-5	11-10	12-3	12-7	13-8	13-5	13-8	14-1	14-8	14-10	15-2	15-5	15-8	15-8	16-1	16-1	
	24.0	4-11	5-8	6-4	6-11	7-8	8-8	8-8	9-11	9-4	9-8	10-2	10-7	10-11	11-3	11-8	12-8	12-4	12-7	12-11	13-3	13-8	13-10	14-1	14-5	14-8	14-8	
2 $\times$ 10	12.0	8-10	10-2	11-5	12-8	13-8	14-5	15-3	16-1	16-11	17-8	18-4	18-1	18-8	20-4	21-0	21-7	22-2	22-8	23-4	23-11							
	18.0	7-8	8-10	9-10	10-10	11-8	12-8	13-3	13-11	14-8	15-3	15-11	16-8	17-1	17-8	18-2	18-8	18-3	18-8	20-2	20-8	21-2	21-7					
	19.2	7-8	8-1	9-8	9-10	10-8	11-5	12-1	12-8	13-4	13-11	14-8	15-1	15-7	16-1	16-7	17-1	17-7	18-8	18-5	18-11	18-4	18-8	18-8	18-8	20-2	20-8	
	24.0	6-3	7-2	8-1	8-10	9-8	10-2	10-10	11-5	11-11	12-8	13-8	13-8	13-11	14-5	14-10	15-3	15-8	16-1	16-8	18-11	17-3	17-8	17-8	17-8	18-8	18-8	
2 $\times$ 12	12.0	10-8	12-5	13-10	15-2	16-5	17-8	18-7	19-7	20-8	21-5	22-4	23-2	24-8	24-8	25-8												
	18.0	8-3	10-8	12-8	13-2	14-2	15-2	16-1	17-8	17-8	18-7	18-4	20-1	20-8	21-5	22-1	22-8	23-5	24-8	24-7	25-2	25-8						
	19.2	8-8	8-10	10-11	12-8	12-11	13-10	14-8	15-8	16-3	17-8	18-4	18-8	18-8	18-7	20-2	20-8	21-4	21-11	22-5	23-8	23-8	24-8	24-8	24-8	25-8	25-8	
	24.0	7-7	8-8	9-10	10-8	11-7	12-5	13-2	13-10	14-8	15-2	15-8	16-5	17-8	17-8	18-1	18-7	19-1	19-7	20-1	20-8	21-8	21-8	21-5	21-11	22-4	22-8	
E	12.0	0.12	0.18	0.27	0.35	0.44	0.54	0.65	0.76	0.88	1.00	1.13	1.26	1.40	1.54	1.68	1.83	1.98	2.15	2.31	2.48							
	18.0	0.11	0.17	0.23	0.31	0.39	0.47	0.56	0.66	0.76	0.86	0.96	1.08	1.21	1.33	1.46	1.60	1.72	1.86	2.00	2.15	2.29	2.45					
	19.2	0.10	0.15	0.21	0.29	0.35	0.43	0.51	0.60	0.69	0.79	0.89	0.99	1.10	1.22	1.33	1.45	1.57	1.70	1.83	1.98	2.08	2.23	2.37	2.52			
	24.0	0.09	0.14	0.19	0.25	0.31	0.38	0.46	0.54	0.62	0.71	0.80	0.89	0.99	1.09	1.20	1.30	1.41	1.52	1.63	1.75	1.87	2.00	2.12	2.25	2.38		

NOTE: The required modulus of elasticity,  $E$ , in 1,000,000 pounds per square inch is shown at the bottom of this table, is limited to 2.6 million psi ( $17.92 \times 10^6$  kN/m<sup>2</sup>) and less, and is applicable to all lumber sizes shown. Spans are shown in feet-inches (1 foot = 304.8 mm, 1 inch = 25.4 mm) and are limited to 26 feet (7925 mm) and less.

**TABLE 23-V-R-4—RAFTERS WITH L/240 DEFLECTION LIMITS**

The allowable bending stress ( $F_b$ ) and modulus of elasticity ( $E$ ) used in this table shall be from Tables 23-I-X-1 and 23-I-X-2 only.

Rafter Size (in)		Spacing (in)		Bending Design Value, $F_b$ (psi) ( $\times 0.00689$ for kN/m <sup>2</sup> )																						
$\times 25.4$ for mm		300	400	500	600	700	800	900	1000	1100	1200	1300	1400	1500	1600	1700	1800	1900	2000	2100	2200	2300	2400	2500	2600	2700
2 $\times$ 8	12.0	4-10	5-7	6-3	6-10	7-4	7-11	8-4	8-10	8-3	8-8	10-0	10-5	10-0	11-2	11-6	11-10	12-2	12-5	12-8	13-1	13-4				
	16.0	4-2	4-10	5-5	5-11	6-5	6-10	7-3	7-8	8-0	8-4	8-0	8-0	8-4	8-0	8-11	10-3	10-6	10-0	11-1	11-4	11-7	11-10	12-1		
	18.2	3-10	4-5	4-11	5-5	5-10	6-3	6-7	7-0	7-4	7-8	7-11	8-3	8-0	8-10	8-1	8-4	8-7	8-10	10-1	10-4	10-7	10-9	11-0	11-3	11-5
	24.0	2-5	3-11	4-5	4-10	5-3	5-7	5-11	6-2	6-6	6-10	7-1	7-4	7-8	7-11	8-1	8-4	8-7	8-10	8-0	8-3	8-5	8-8	8-10	10-0	10-3
2 $\times$ 10	12.0	6-4	7-4	8-3	8-8	9-8	10-5	11-0	11-7	12-2	12-8	13-3	13-8	14-3	14-8	15-2	15-7	16-0	16-5	16-10	17-3	17-7				
	16.0	5-8	6-4	7-1	7-8	8-5	8-8	8-8	10-1	10-7	11-0	11-0	11-11	12-4	12-8	13-1	13-8	13-10	14-3	14-7	14-11	15-3	15-7	15-11		
	18.2	5-0	5-10	6-0	7-1	7-8	8-3	8-8	8-2	8-8	10-1	10-6	10-10	11-3	11-7	12-0	12-4	12-8	13-0	13-4	13-7	13-11	14-3	14-8	14-10	15-1
	24.0	4-0	5-2	5-10	6-4	6-10	7-4	7-8	8-2	8-7	8-8	8-4	8-8	10-1	10-5	10-9	11-0	11-4	11-7	11-11	12-2	12-5	12-8	12-8	12-8	12-8
2 $\times$ 12	12.0	8-1	8-4	10-8	11-8	12-5	13-3	14-1	14-10	15-8	16-3	16-11	17-8	18-2	18-8	18-4	18-10	20-5	20-11	21-8	22-0	22-8				
	16.0	7-0	8-1	8-1	8-11	10-8	11-8	12-2	12-10	13-5	14-1	14-8	15-2	15-8	16-3	16-8	17-3	17-8	18-2	18-7	18-8	19-5	19-10	20-3		
	18.2	6-5	7-5	8-3	8-1	8-10	10-8	11-1	11-8	12-3	12-10	13-4	13-10	14-4	14-10	15-3	15-9	16-2	16-7	17-0	17-4	17-8	18-2	18-8	18-11	19-3
	24.0	5-0	6-7	7-5	8-1	8-8	9-4	9-11	10-8	11-0	11-8	11-11	12-5	12-10	13-3	13-8	14-1	14-5	14-10	15-2	15-8	15-11	16-3	16-7	16-11	17-3
E	12.0	0.12	0.18	0.26	0.34	0.43	0.53	0.63	0.74	0.85	0.97	1.10	1.22	1.36	1.50	1.64	1.78	1.94	2.08	2.25	2.41	2.58				
	16.0	0.11	0.16	0.23	0.30	0.37	0.46	0.55	0.64	0.74	0.84	0.96	1.08	1.18	1.30	1.42	1.55	1.68	1.81	1.95	2.08	2.23	2.38	2.53		
	18.2	0.10	0.15	0.21	0.27	0.34	0.42	0.50	0.58	0.67	0.77	0.87	0.97	1.07	1.18	1.30	1.41	1.53	1.65	1.78	1.81	2.04	2.17	2.31	2.45	2.58
	24.0	0.08	0.13	0.18	0.24	0.31	0.37	0.45	0.52	0.60	0.68	0.77	0.87	0.96	1.06	1.16	1.25	1.37	1.48	1.58	1.71	1.82	1.94	2.07	2.18	2.32

**NOTE:** The required modulus of elasticity,  $E$ , in 1,000,000 pounds per square inch is shown at the bottom of this table, is limited to 2.6 million psi ( $17.92 \times 10^6$  kN/m<sup>2</sup>) and less, and is applicable to all lumber sizes shown. Spans are shown in feet-inches (1 foot = 304.8 mm, 1 inch = 25.4 mm) and are limited to 26 feet (7925 mm) and less.

**TABLE 23-V-R-5—RAFTERS WITH L/240 DEFLECTION LIMITS**

The allowable bending stress ( $F_b$ ) and modulus of elasticity ( $E$ ) used in this table shall be from Tables 23-I-X-1 and 23-I-X-2 only.

Rafter Size (in)		Spacing (in)		Bending Design Value, $F_b$ (psi) ( $\times 0.00689$ for $\text{kN/m}^2$ )																							
$\times 25.4$ for mm		300	400	500	600	700	800	900	1000	1100	1200	1300	1400	1500	1600	1700	1800	1900	2000	2100	2200	2300	2400	2500	2600	2700	
2 $\times$ 8	12.0	5-0	5-10	6-0	7-1	7-8	8-2	8-8	8-2	8-7	10-0	10-5	10-10	11-3	11-7	11-11	12-4	12-8	13-0	13-3	13-7	13-11	14-2				
	16.0	4-4	5-0	5-7	6-2	6-8	7-1	7-8	7-11	8-4	8-8	9-1	9-5	9-9	10-0	10-4	10-8	10-11	11-3	11-8	11-8	12-0	12-4	12-7	12-10	13-1	
	19.2	4-0	4-7	5-1	5-7	6-1	6-8	6-10	7-3	7-7	7-11	8-3	8-7	8-11	9-2	9-5	9-8	10-0	10-3	10-8	10-8	11-0	11-3	11-5	11-8	11-11	
24.0	3-7	4-1	4-7	5-0	5-5	5-10	6-2	6-6	6-10	7-1	7-5	7-8	7-11	8-2	8-5	8-8	9-11	9-2	9-5	9-7	9-10	10-0	10-3	10-5	10-8	10-8	
2 $\times$ 8	12.0	6-7	7-0	8-7	8-4	10-1	10-10	11-0	12-1	12-8	13-3	13-8	14-4	14-10	15-3	15-8	16-3	16-8	17-1	17-8	17-11	18-4	18-8				
	16.0	5-8	6-7	7-5	8-1	8-8	9-4	9-11	10-8	11-0	11-8	11-11	12-5	12-10	13-3	13-8	14-0	14-5	14-10	15-2	15-8	15-10	16-3	16-7	16-10	17-2	
	19.2	5-3	6-0	6-8	7-5	8-0	8-7	9-1	9-7	10-0	10-8	10-11	11-4	11-8	12-1	12-5	12-10	13-2	13-8	13-10	14-2	14-8	14-10	15-1	15-5	15-8	
24.0	4-8	5-5	6-0	6-7	7-2	7-8	8-1	8-7	9-0	9-4	9-8	10-1	10-8	10-10	11-2	11-8	11-8	12-1	12-5	12-8	12-11	13-3	13-8	13-8	14-0	14-0	
2 $\times$ 10	12.0	8-5	8-8	10-11	11-11	12-11	13-8	14-8	15-5	16-2	16-11	17-7	18-3	18-11	18-8	20-1	20-8	21-3	21-10	22-4	22-10	23-5	23-11				
	16.0	7-4	8-5	9-5	10-4	11-2	11-11	12-0	13-4	14-0	14-8	15-3	15-10	16-4	16-11	17-5	17-11	18-5	18-11	19-4	19-10	20-3	20-8	21-1	21-6	21-11	
	19.2	6-8	7-8	8-7	9-5	10-2	10-11	11-7	12-2	12-9	13-4	13-11	14-5	14-11	15-5	15-11	16-4	16-10	17-3	17-8	18-1	18-8	18-11	19-3	19-8	20-0	
24.0	6-0	6-11	7-8	8-5	9-1	9-8	10-4	10-11	11-5	11-11	12-5	12-11	13-4	13-8	14-3	14-8	15-0	15-5	15-10	16-2	16-8	16-11	17-3	17-7	17-11		
2 $\times$ 12	12.0	10-3	11-10	12-3	14-8	15-8	16-8	17-8	18-8	19-8	20-8	21-5	22-2	23-0	23-8	24-5	25-2	25-10									
	16.0	8-11	10-3	11-6	12-7	13-7	14-8	15-5	16-3	17-0	17-8	18-8	18-11	19-11	20-0	21-2	21-8	22-5	23-0	23-8	24-1	24-8	25-2	25-8			
	19.2	8-1	9-4	10-6	11-8	12-5	13-3	14-1	14-10	15-7	16-3	16-11	17-8	18-2	19-0	19-4	19-11	20-5	21-0	21-8	22-0	22-8	23-0	23-5	23-11	24-4	
24.0	7-3	8-5	9-4	10-3	11-1	11-10	12-7	13-3	13-11	14-8	15-1	15-8	16-3	16-8	17-3	17-8	18-3	18-8	19-0	19-3	19-8	20-1	20-8	21-0	21-5	21-8	
E	12.0	0.11	0.17	0.24	0.31	0.38	0.46	0.57	0.67	0.77	0.86	0.96	1.10	1.22	1.35	1.48	1.61	1.76	1.88	2.03	2.18	2.33	2.48				
	16.0	0.09	0.15	0.20	0.27	0.34	0.41	0.48	0.58	0.67	0.76	0.86	0.96	1.08	1.17	1.28	1.38	1.51	1.63	1.76	1.88	2.01	2.15	2.28	2.42	2.58	
	19.2	0.08	0.13	0.18	0.24	0.31	0.38	0.45	0.53	0.61	0.69	0.78	0.87	0.97	1.07	1.17	1.27	1.38	1.48	1.60	1.72	1.84	1.96	2.08	2.21	2.34	
24.0	0.06	0.12	0.17	0.22	0.28	0.34	0.40	0.47	0.54	0.62	0.70	0.78	0.87	0.95	1.04	1.14	1.23	1.33	1.43	1.54	1.64	1.75	1.86	1.98	2.08		

**NOTE:** The required modulus of elasticity,  $E$ , in 1,000,000 pounds per square inch is shown at the bottom of this table, is limited to 2.6 million psi ( $17.92 \times 10^6 \text{ kN/m}^2$ ) and less, and is applicable to all lumber sizes shown. Spans are shown in feet-inches (1 foot = 304.8 mm, 1 inch = 25.4 mm) and are limited to 26 feet (7925 mm) and less.

**TABLE 23-V-R-6—RAFTERS WITH L/240 DEFLECTION LIMITS**

The allowable bending stress ( $F_b$ ) and modulus of elasticity ( $E$ ) used in this table shall be from Tables 23-I-X-1 and 23-I-X-2 only.

DESIGN CRITERIA: Strength — Live load of 50 psf (2.40 kN/m <sup>2</sup> ) plus dead load of 20 psf (0.96 kN/m <sup>2</sup> ) determines the required bending design value. Deflection — For 50 psf (2.40 kN/m <sup>2</sup> ) live load. Limited to span in inches (mm) divided by 240.																										
Rafter Size (in)	Spacing (in)	Bending Design Value, $F_b$ (psi) ( $\times 0.00689$ for kN/m <sup>2</sup> )																								
$\times 25.4$ for mm		300	400	500	600	700	800	900	1000	1100	1200	1300	1400	1500	1600	1700	1800	1900	2000	2100	2200	2300	2400	2500	2600	2700
2 $\times$ 8	12.0	4-0	5-4	6-8	6-7	7-1	7-7	8-1	8-8	8-11	8-4	8-8	10-0	10-5	10-8	11-1	11-5	11-8	12-8	12-4	12-7	12-10	12-2			
	18.0	4-0	4-0	5-2	5-8	6-2	6-7	7-0	7-4	7-8	8-1	8-5	8-8	8-0	8-4	8-7	8-10	10-2	10-5	10-8	10-11	11-2	11-5	11-7	11-10	12-1
	24.0	3-3	3-10	4-3	4-0	5-2	5-7	6-0	6-4	6-8	7-0	7-4	7-8	7-11	8-3	8-8	8-0	8-0	8-3	8-6	8-9	8-11	8-2	8-4	8-6	8-8
2 $\times$ 10	12.0	6-2	7-1	7-11	8-8	8-4	10-0	10-7	11-2	11-8	12-3	12-8	13-3	13-8	14-2	14-7	15-0	15-5	15-10	16-3	16-7	17-0	17-4			
	18.0	5-4	6-2	6-10	7-0	8-1	8-8	8-2	8-8	10-2	10-7	11-1	11-8	11-10	12-3	12-8	13-0	13-4	13-8	14-0	14-4	14-8	15-0	15-4	15-7	15-11
	24.0	4-4	5-0	5-7	6-2	6-7	7-1	7-8	7-11	8-4	8-8	8-8	8-4	8-8	10-0	10-4	10-7	10-11	11-2	11-8	11-8	12-0	12-3	12-8	12-8	12-8
2 $\times$ 12	12.0	7-10	8-0	10-1	11-1	11-11	12-8	13-8	14-3	15-8	15-8	16-3	16-11	17-8	18-1	18-7	18-2	18-8	20-2	20-8	21-2	21-8	22-1			
	18.0	6-0	7-10	8-0	8-7	10-4	11-1	11-8	12-4	13-0	13-8	14-1	14-8	15-2	15-8	16-1	16-7	17-0	17-8	17-11	18-4	18-8	18-2	18-7	18-11	20-4
	24.0	5-0	6-5	7-2	7-10	8-5	8-0	8-7	10-1	10-7	11-1	11-8	11-11	12-4	12-8	13-2	13-8	13-11	14-3	14-8	15-0	15-4	15-8	15-11	16-3	16-7
2 $\times$ 14	12.0	8-8	11-0	12-3	13-5	14-8	15-8	16-8	17-4	18-2	18-8	18-10	20-8	21-3	21-11	22-8	23-3	23-11	24-7	25-2	25-8					
	18.0	8-3	8-8	10-8	11-8	12-7	13-5	14-3	15-8	15-8	16-8	17-2	17-8	18-5	18-8	18-7	20-2	20-8	21-3	21-8	22-4	22-10	23-3	23-8	24-3	24-8
	24.0	7-8	8-8	9-8	10-8	11-8	12-3	13-8	13-8	14-5	15-8	15-8	16-3	16-10	17-4	17-11	18-5	18-11	18-5	18-11	20-4	20-10	21-3	21-8	22-2	22-7
E	12.0	0.11	0.17	0.23	0.31	0.38	0.47	0.58	0.68	0.76	0.87	0.96	1.10	1.21	1.34	1.47	1.60	1.73	1.87	2.01	2.18	2.31	2.46			
	18.0	0.80	0.14	0.20	0.27	0.34	0.41	0.49	0.57	0.66	0.75	0.85	0.95	1.06	1.18	1.27	1.38	1.50	1.62	1.74	1.87	2.00	2.13	2.28	2.40	2.54
	24.0	0.80	0.13	0.18	0.24	0.31	0.37	0.45	0.52	0.60	0.69	0.77	0.87	0.96	1.06	1.18	1.29	1.37	1.48	1.58	1.71	1.82	1.94	2.07	2.18	2.32
	24.0	0.80	0.12	0.17	0.22	0.27	0.33	0.40	0.47	0.54	0.61	0.69	0.77	0.86	0.95	1.04	1.13	1.22	1.32	1.42	1.53	1.63	1.74	1.85	1.96	2.07

NOTE: The required modulus of elasticity,  $E$ , in 1,000,000 pounds per square inch is shown at the bottom of this table, is limited to 2.6 million psi ( $17.92 \times 10^6$  kN/m<sup>2</sup>) and less, and is applicable to all lumber sizes shown. Spans are shown in feet-inches (1 foot = 304.8 mm, 1 inch = 25.4 mm) and are limited to 26 feet (7925 mm) and less.

TABLE 23-V-R-7—RAFTERS WITH L/180 DEFLECTION LIMITS

The allowable bending stress ( $F_b$ ) and modulus of elasticity ( $E$ ) used in this table shall be from Tables 23-I-X-1 and 23-I-X-2 only.

DESIGN CRITERIA:

Strength — Live load of 40 psf (1.92 kN/m<sup>2</sup>) plus dead load of 10 psf (0.48 kN/m<sup>2</sup>) determines the required bending design value.

Deflection — For 40 psf (1.92 kN/m<sup>2</sup>) live load.

Limited to span in inches (mm) divided by 180.

Rafter Size (in)		Bending Design Value, $F_b$ (psi) ( $\times 0.00689$ for kN/m <sup>2</sup> )																														
		$\times 25.4$ mm																														
		200	300	400	500	600	700	800	900	1000	1100	1200	1300	1400	1500	1600	1700	1800	1900	2000	2100	2200	2300	2400	2500	2600	2700	2800	2900	3000		
2 $\times$ 4	12.0	2-10	3-0	4-0	4-8	4-11	5-4	5-8	6-1	6-5	6-8	7-0	7-3	7-7	7-10	8-1	8-4	8-7	8-10	8-8	8-3	8-8	8-8	8-11	10-1							
	16.0	2-8	3-0	3-8	3-11	4-3	4-8	4-11	5-3	5-8	5-10	6-1	6-4	6-7	6-9	7-0	7-3	7-5	7-8	7-10	8-0	8-2	8-5	8-7	8-8	8-11	8-1					
	18.2	2-8	2-8	3-2	3-7	3-11	4-3	4-8	4-10	5-1	5-4	5-8	5-8	6-0	6-2	6-5	6-7	6-8	7-0	7-2	7-4	7-8	7-8	7-10	8-0	8-2	8-4	8-5	8-7			
	24.0	2-8	2-8	2-10	3-2	3-8	3-8	4-0	4-3	4-8	4-8	4-11	5-2	5-4	5-8	5-8	5-11	6-1	6-3	6-5	6-7	6-8	6-10	7-0	7-2	7-3	7-5	7-7	7-8	7-8	7-10	
2 $\times$ 6	12.0	4-8	5-8	6-4	7-1	7-8	8-5	8-8	8-8	10-0	10-8	11-0	11-5	11-11	12-4	12-8	13-1	13-6	13-10	14-2	14-7	14-11	15-3	15-7	15-11							
	16.0	3-11	4-8	5-8	6-2	6-8	7-3	7-8	8-3	8-8	9-1	9-6	9-11	10-3	10-8	11-0	11-4	11-8	12-0	12-4	12-7	12-11	13-2	13-8	13-8	14-0	14-3					
	18.2	3-7	4-4	5-8	5-7	6-2	6-8	7-1	7-6	7-11	8-4	8-8	8-1	8-5	8-8	10-0	10-4	10-8	10-11	11-3	11-8	11-8	12-0	12-4	12-7	12-10	13-1	13-3	13-8	13-8		
	24.0	3-2	3-11	4-8	5-8	5-8	5-11	6-4	6-8	7-1	7-5	7-8	8-1	8-5	8-8	9-8	9-3	9-8	9-8	10-0	10-3	10-8	10-8	10-8	11-0	11-3	11-5	11-8	11-11	12-1	12-4	
2 $\times$ 8	12.0	5-11	7-3	8-4	8-4	10-3	11-1	11-10	12-7	13-3	13-11	14-8	15-1	15-8	16-3	16-8	17-3	17-8	18-3	18-8	18-2	18-8	18-8	20-1	20-8	20-11						
	16.0	5-2	6-3	7-3	8-1	8-11	9-7	10-3	10-10	11-8	12-8	12-7	13-1	13-7	14-8	14-8	14-11	15-5	15-10	16-3	16-7	17-8	17-5	17-8	18-1	18-8	18-10	17-2	17-8	17-10		
	18.2	4-8	5-8	6-7	7-5	8-1	8-8	9-4	9-11	10-8	11-0	11-8	11-11	12-5	12-10	13-3	13-8	14-0	14-5	14-10	15-2	15-8	15-10	16-3	16-7	16-10	17-2	17-8	17-10			
	24.0	4-2	5-11	6-7	7-3	7-8	7-10	8-4	8-11	9-4	9-10	10-3	10-8	11-1	11-8	11-10	12-2	12-7	12-11	13-3	13-7	13-11	14-2	14-8	14-10	15-1	15-5	15-8	15-11	16-3	16-8	
2 $\times$ 10	12.0	7-7	8-3	10-8	11-11	12-1	14-2	15-1	16-8	16-11	17-8	18-8	19-3	20-8	21-4	22-0	22-8	23-3	23-11	24-6	25-1	25-7										
	16.0	6-8	6-8	8-3	10-4	11-4	12-3	13-1	13-10	14-8	15-4	16-8	16-8	17-4	17-11	18-8	18-1	18-7	20-2	20-8	21-2	21-8	22-2	22-8	23-1	23-7	24-8					
	18.2	6-8	7-4	8-5	9-5	10-4	11-2	11-11	12-8	13-4	14-8	14-8	15-3	15-10	16-4	16-11	17-5	17-11	18-5	18-11	18-4	18-10	20-3	20-8	21-1	21-8	21-11	22-4	22-8			
	24.0	5-4	6-8	7-7	8-5	8-3	10-8	11-4	11-11	12-8	13-1	13-7	14-2	14-8	15-1	15-7	16-8	16-8	18-11	17-4	17-8	18-1	18-10	18-1	18-8	18-11	18-3	18-7	20-8	20-4	20-8	
E	12.0	0.86	0.11	0.17	0.23	0.31	0.38	0.47	0.58	0.68	0.78	0.86	0.97	1.08	1.21	1.32	1.48	1.58	1.72	1.86	2.00	2.14	2.28	2.44	2.60							
	16.0	0.85	0.80	0.14	0.20	0.28	0.33	0.41	0.48	0.57	0.66	0.75	0.84	0.94	1.05	1.15	1.28	1.37	1.49	1.61	1.73	1.88	1.99	2.12	2.25	2.38	2.53					
	18.2	0.85	0.80	0.13	0.18	0.24	0.30	0.37	0.44	0.52	0.60	0.68	0.77	0.86	0.95	1.05	1.15	1.25	1.36	1.47	1.58	1.70	1.81	1.93	2.05	2.18	2.31	2.43	2.57			
	24.0	0.84	0.80	0.12	0.18	0.22	0.27	0.33	0.40	0.48	0.54	0.61	0.68	0.77	0.85	0.94	1.03	1.12	1.22	1.31	1.41	1.52	1.62	1.73	1.84	1.95	2.06	2.18	2.30	2.41		

NOTE: The required modulus of elasticity,  $E$ , in 1,000,000 pounds per square inch is shown at the bottom of this table, is limited to 2.6 million psi ( $17.92 \times 10^6$  kN/m<sup>2</sup>) and less, and is applicable to all lumber sizes shown. Spans are shown in feet-inches (1 foot = 304.8 mm, 1 inch = 25.4 mm) and are limited to 26 feet (7925 mm) and less.

TABLE 23-V-R-8—RAFTERS WITH L/180 DEFLECTION LIMITS

The allowable bending stress ( $F_b$ ) and modulus of elasticity ( $E$ ) used in this table shall be from Tables 23-I-X-1 and 23-I-X-2 only.

DESIGN CRITERIA:

Strength — Live load of 50 psf (2.40 kN/m<sup>2</sup>) plus dead load of 10 psf (0.48 kN/m<sup>2</sup>) determines the required bending design value.

Deflection — For 50 psf (2.40 kN/m<sup>2</sup>) live load.

Limited to span in inches (mm) divided by 180.

Bending Design Value,  $F_b$  (psi) ( $\times 0.00689$  for kN/m<sup>2</sup>)

Rafter Spacing (in)	$\times 25.4$ mm	200	300	400	500	600	700	800	900	1000	1100	1200	1300	1400	1500	1600	1700	1800	1900	2000	2100	2200	2300	2400	2500	2600	2700	2800	2900	3000	
		2 x 4	12.0	2-7	3-2	3-8	4-1	4-8	4-11	5-3	5-6	5-10	6-1	6-5	6-8	6-11	7-2	7-5	7-7	7-10	8-0	8-3	8-5	8-8	8-10	8-8	8-3	8-2	8-4	8-5	
	18.0	2-3	2-9	3-2	3-7	3-11	4-3	4-8	4-10	5-1	5-4	5-6	5-8	6-0	6-2	6-5	6-7	6-9	7-0	7-2	7-4	7-6	7-8	7-10	8-0	8-0	8-2	8-4	8-5		
	18.2	2-1	2-6	2-11	3-3	3-7	3-10	4-1	4-4	4-7	4-10	5-1	5-3	5-5	5-8	5-10	6-0	6-2	6-4	6-6	6-8	6-10	7-0	7-2	7-3	7-5	7-7	7-8	7-10	8-0	
	24.0	1-10	2-3	2-7	2-11	3-2	3-5	3-8	3-11	4-1	4-4	4-8	4-8	4-11	5-1	5-3	5-5	5-8	5-8	5-8	5-10	6-0	6-1	6-3	6-5	6-8	6-8	6-8	6-11	7-0	7-2
2 x 6	12.0	4-1	5-0	5-10	6-0	7-1	7-8	8-2	8-8	8-2	8-7	10-0	10-5	10-10	11-3	11-7	11-11	12-4	12-8	13-0	13-3	13-7	13-11	14-2	14-8						
	18.0	3-7	4-4	5-0	5-7	6-2	6-8	7-1	7-6	7-11	8-4	8-8	8-1	8-5	8-8	10-0	10-4	10-8	10-11	11-3	11-6	11-8	12-0	12-4	12-7	12-10	13-1	13-3			
	18.2	3-3	4-0	4-7	5-1	5-7	6-1	6-8	6-10	7-3	7-7	7-11	8-3	8-7	8-11	8-2	8-5	8-8	10-0	10-3	10-6	10-8	11-0	11-3	11-5	11-8	11-11	12-2	12-4	12-7	
	24.0	2-11	3-7	4-1	4-7	5-8	5-5	5-10	6-2	6-8	6-10	7-1	7-5	7-8	7-11	8-2	8-5	8-8	8-11	8-2	8-5	8-7	8-10	10-0	10-3	10-5	10-8	10-10	11-0	11-3	
2 x 8	12.0	5-5	6-7	7-8	8-7	8-4	10-1	10-10	11-6	12-1	12-8	13-3	13-8	14-4	14-10	15-3	15-8	16-3	16-8	17-1	17-6	17-11	18-4	18-8	18-1						
	18.0	4-8	5-8	6-7	7-5	8-1	8-8	9-4	9-11	10-8	11-0	11-8	11-11	12-5	12-10	13-3	13-8	14-8	14-5	14-10	15-2	15-8	15-10	16-3	16-7	16-10	17-2	17-8			
	18.2	4-3	5-3	6-0	6-8	7-5	8-8	8-7	9-1	9-7	10-8	10-8	10-11	11-4	11-8	12-1	12-5	12-10	13-2	13-8	13-10	14-2	14-8	14-10	15-1	15-5	15-8	16-8	16-8	16-7	
	24.0	3-10	4-8	5-5	6-8	6-7	7-2	7-8	8-1	8-7	8-8	8-4	8-8	10-1	10-8	10-10	11-2	11-8	11-8	12-1	12-5	12-8	12-11	13-3	13-8	13-8	14-0	14-4	14-7	14-10	
2 x 10	12.0	6-11	8-5	9-8	10-11	11-11	12-11	13-8	14-8	15-5	16-2	16-11	17-7	18-3	18-11	18-8	20-1	20-8	21-3	21-10	22-4	22-10	23-5	23-11	24-5						
	18.0	6-0	7-4	8-5	9-5	10-4	11-2	11-11	12-8	13-4	14-8	14-8	15-3	15-10	16-4	16-11	17-5	17-11	18-5	18-11	18-4	18-10	19-3	19-8	20-1	21-1	21-8	21-11	22-4		
	18.2	5-5	6-8	7-8	8-7	9-5	10-2	10-11	11-7	12-2	12-8	13-4	13-11	14-5	14-11	15-5	15-11	16-4	16-10	17-3	17-8	18-1	18-8	18-11	19-3	19-8	20-8	20-5	20-8	21-1	
	24.0	4-11	6-0	6-11	7-8	8-5	9-1	9-8	10-4	10-11	11-5	11-11	12-5	12-11	13-4	13-8	14-3	14-8	15-8	15-5	15-10	16-2	16-8	16-11	17-3	17-7	17-11	18-3	18-7	18-11	
E	12.0	0.80	0.10	0.10	0.22	0.20	0.37	0.45	0.53	0.63	0.72	0.82	0.93	1.04	1.15	1.26	1.38	1.51	1.64	1.77	1.90	2.04	2.18	2.32	2.47						
	18.0	0.85	0.80	0.14	0.18	0.25	0.32	0.38	0.46	0.54	0.62	0.71	0.80	0.90	1.00	1.10	1.20	1.31	1.42	1.53	1.65	1.77	1.90	2.01	2.14	2.27	2.40	2.54			
	18.2	0.84	0.86	0.13	0.17	0.23	0.29	0.35	0.42	0.48	0.57	0.65	0.73	0.82	0.91	1.00	1.10	1.18	1.28	1.40	1.50	1.61	1.72	1.84	1.95	2.07	2.19	2.32	2.44	2.57	
	24.0	0.84	0.87	0.11	0.16	0.21	0.28	0.32	0.38	0.44	0.51	0.58	0.66	0.73	0.81	0.89	0.98	1.07	1.16	1.25	1.34	1.44	1.54	1.64	1.75	1.85	1.96	2.07	2.18	2.28	

NOTE: The required modulus of elasticity,  $E$ , in 1,000,000 pounds per square inch is shown at the bottom of this table, is limited to 2.6 million psi ( $17.92 \times 10^6$  kN/m<sup>2</sup>) and less, and is applicable to all lumber sizes shown. Spans are shown in feet-inches (1 foot = 304.8 mm, 1 inch = 25.4 mm) and are limited to 26 feet (7925 mm) and less.

**TABLE 23-V-R-9—RAFTERS WITH L/180 DEFLECTION LIMITS**

The allowable bending stress ( $F_b$ ) and modulus of elasticity ( $E$ ) used in this table shall be from Tables 23-I-X-1 and 23-I-X-2 only.

DESIGN CRITERIA:																															
Strength — Live load of 40 psf (1.92 kN/m <sup>2</sup> ) plus dead load of 15 psf (0.72 kN/m <sup>2</sup> ) determines the required bending design value.																															
Deflection — For 40 psf (1.92 kN/m <sup>2</sup> ) live load.																															
Limited to span in inches (mm) divided by 180.																															
Rafter Size (in)	Span (ft)	Bending Design Value, $F_b$ (psi) ( $\times 0.00689$ kN/m <sup>2</sup> )																													
		200	300	400	500	600	700	800	900	1000	1100	1200	1300	1400	1500	1600	1700	1800	1900	2000	2100	2200	2300	2400	2500	2600	2700	2800	2900	3000	
2 × 4	12.0	2-0	3-4	3-10	4-4	4-8	5-1	5-5	5-8	6-1	6-5	6-8	6-11	7-3	7-8	7-8	7-11	8-2	8-5	8-7	8-10	8-8	8-3	8-5	8-8	8-10	10-0				
	18.0	2-4	2-11	3-4	3-8	4-1	4-5	4-8	5-0	5-3	5-8	5-8	6-0	6-3	6-8	6-8	6-11	7-1	7-3	7-8	7-8	7-10	8-0	8-2	8-4	8-8	8-8	8-10	8-8	8-2	
	19.2	2-2	2-8	3-1	3-5	3-8	4-0	4-4	4-7	4-10	5-1	5-3	5-8	5-8	5-11	6-1	6-3	6-8	6-8	6-10	7-0	7-2	7-4	7-8	7-7	7-8	7-11	8-1	8-2	8-4	
	24.0	1-11	2-4	2-8	3-1	3-4	3-7	3-10	4-1	4-4	4-8	4-8	4-11	5-1	5-3	5-5	5-7	5-8	5-11	6-1	6-3	6-5	6-8	6-8	6-10	6-11	7-1	7-3	7-4	7-8	
2 × 6	12.0	4-3	5-8	6-1	6-8	7-5	8-0	8-7	9-1	9-7	10-8	10-8	10-11	11-4	11-8	12-1	12-8	12-10	13-2	13-8	13-10	14-2	14-8	14-10	15-2	15-5	15-8				
	18.0	3-8	4-8	5-3	5-10	6-5	6-11	7-5	7-10	8-3	8-8	8-1	8-5	9-10	10-2	10-8	10-10	11-1	11-5	11-8	12-0	12-4	12-7	12-10	13-1	13-4	13-7	13-10	14-1	14-4	
	19.2	3-5	4-2	4-8	5-4	5-10	6-4	6-8	7-2	7-7	7-11	8-3	8-8	9-11	9-3	9-7	9-10	10-2	10-5	10-8	11-0	11-3	11-8	11-8	12-0	12-2	12-5	12-8	12-11	13-1	
	24.0	3-8	3-8	4-3	4-8	5-3	5-8	6-1	6-5	6-8	7-1	7-5	7-8	8-0	8-3	8-7	8-10	9-1	9-4	9-7	9-10	10-8	10-3	10-8	10-8	10-11	11-1	11-4	11-8	11-8	
2 × 8	12.0	5-8	6-11	6-8	6-11	6-8	10-7	11-3	12-0	12-7	13-3	13-10	14-5	14-11	15-5	16-8	16-5	16-11	17-5	17-10	18-3	18-8	18-2	18-7	18-11	20-4	20-8				
	18.0	4-11	6-0	6-11	7-8	8-8	9-8	10-4	10-11	11-8	12-0	12-8	12-11	13-5	13-10	14-3	14-8	15-1	15-5	15-10	16-3	16-7	16-11	17-3	17-7	18-0	18-3	18-7	18-0	18-7	18-11
	19.2	4-8	5-8	6-4	7-1	7-8	8-4	8-11	9-8	10-8	10-8	10-11	11-5	11-10	12-3	12-7	13-8	13-8	13-8	14-1	14-8	14-10	15-2	15-5	15-8	16-1	16-5	16-8	17-0	17-8	
	24.0	4-8	4-11	5-8	6-4	6-11	7-8	8-8	8-8	8-11	9-4	9-8	10-2	10-7	10-11	11-3	11-8	12-8	12-4	12-7	12-11	13-3	13-8	13-10	14-1	14-5	14-8	14-11	15-2	15-5	
2 × 10	12.0	7-2	8-10	10-2	11-5	12-8	13-8	14-5	15-3	16-1	16-11	17-8	18-4	18-1	18-8	20-4	21-8	21-7	22-2	22-8	23-4	23-11	24-5	24-11	25-8	26-8					
	18.0	6-3	7-8	8-10	9-10	10-10	11-8	12-8	13-3	13-11	14-8	15-3	15-11	16-8	17-1	17-8	18-2	18-8	18-3	18-8	20-2	20-8	21-2	21-7	22-1	22-8	22-11	23-4	23-8	24-2	
	19.2	5-8	7-8	8-1	8-8	9-10	10-8	11-5	12-1	12-8	13-4	13-11	14-8	15-1	15-7	16-1	16-7	17-1	17-7	18-8	18-5	18-11	18-4	18-8	20-2	20-8	20-11	21-4	21-8	22-1	
	24.0	5-1	6-3	7-2	8-1	8-10	9-8	10-2	10-10	11-5	11-11	12-8	13-8	13-8	13-11	14-5	14-10	15-3	15-8	16-1	16-8	18-11	17-3	17-8	18-8	18-4	18-8	19-1	19-5	19-8	
E	12.0	0.85	0.80	0.14	0.29	0.29	0.33	0.41	0.48	0.57	0.68	0.73	0.84	0.84	1.05	1.15	1.26	1.38	1.48	1.61	1.70	1.88	1.88	2.12	2.25	2.38	2.53				
	18.0	0.94	0.80	0.12	0.17	0.22	0.26	0.32	0.35	0.42	0.48	0.57	0.65	0.72	0.81	0.96	1.06	1.18	1.28	1.40	1.50	1.61	1.72	1.83	1.95	2.07	2.18	2.31	2.44	2.58	
	19.2	0.94	0.87	0.11	0.16	0.21	0.26	0.32	0.38	0.45	0.52	0.58	0.67	0.75	0.83	0.91	1.00	1.08	1.18	1.27	1.37	1.47	1.57	1.67	1.78	1.88	2.00	2.11	2.22	2.34	
	24.0	0.94	0.87	0.10	0.14	0.19	0.24	0.29	0.34	0.40	0.46	0.53	0.60	0.67	0.74	0.82	0.89	0.97	1.06	1.14	1.23	1.31	1.41	1.50	1.59	1.68	1.78	1.88	1.98	2.08	

NOTE: The required modulus of elasticity,  $E$ , in 1,000,000 pounds per square inch is shown at the bottom of this table, is limited to 2.6 million psi ( $17.92 \times 10^6$  kN/m<sup>2</sup>) and less, and is applicable to all lumber sizes shown. Spans are shown in feet-inches (1 foot = 304.8 mm, 1 inch = 25.4 mm) and are limited to 26 feet (7925 mm) and less.

TABLE 23-V-R-10—RAFTERS WITH L/180 DEFLECTION LIMITS

The allowable bending stress ( $F_b$ ) and modulus of elasticity ( $E$ ) used in this table shall be from Tables 23-I-X-1 and 23-I-X-2 only.

DESIGN CRITERIA:

Strength — Live load of 50 psf (2.40 kN/m<sup>2</sup>) plus dead load of 15 psf (0.72 kN/m<sup>2</sup>) determines the required bending design value.

Deflection — For 50 psf (2.40 kN/m<sup>2</sup>) live load.

Limited to span in inches (mm) divided by 180.

Bending Design Value,  $F_b$  (psi) ( $\times 0.00689$  kN/m<sup>2</sup>)

Rafter Spacing (in) (mm)	Span (ft) (mm)																													
	200	300	400	500	600	700	800	900	1000	1100	1200	1300	1400	1500	1600	1700	1800	1900	2000	2100	2200	2300	2400	2500	2600	2700	2800	2900	3000	
2 × 4	12.0	2-0	3-1	3-7	4-0	4-4	4-8	5-0	5-4	5-7	5-11	5-2	5-5	5-8	5-10	7-1	7-4	7-8	7-8	7-11	8-1	8-4	8-8	8-8	8-10	8-8	8-3	8-5	8-3	8-5
	18.0	2-2	2-8	3-1	3-5	3-8	4-1	4-4	4-7	4-10	5-1	5-4	5-8	5-8	5-11	6-2	6-4	6-8	6-8	6-10	7-0	7-2	7-4	7-8	7-8	7-10	8-0	8-1	8-3	8-5
	24.0	2-0	2-5	2-10	3-2	3-5	3-8	4-0	4-2	4-5	4-8	4-10	5-1	5-3	5-5	5-7	5-8	5-11	6-1	6-3	6-5	6-7	6-8	6-10	7-0	7-2	7-3	7-5	7-7	7-4
2 × 6	12.0	3-11	4-10	5-7	6-3	6-10	7-4	7-11	8-4	8-10	8-3	8-3	10-0	10-5	10-9	11-2	11-8	11-10	12-2	12-5	12-8	13-1	13-4	13-8	13-11	14-2	14-6	14-8	14-8	14-8
	18.0	3-5	4-2	4-10	5-5	5-11	6-5	6-10	7-3	7-8	8-0	8-4	8-8	8-8	8-4	9-8	9-11	10-3	10-8	10-8	11-1	11-4	11-7	11-10	12-1	12-4	12-8	12-8	13-0	13-3
	24.0	3-1	3-10	4-5	4-11	5-5	5-10	6-3	6-7	7-8	7-4	7-8	7-11	8-3	8-8	8-10	9-1	9-4	9-7	9-10	10-1	10-4	10-7	10-8	11-0	11-3	11-5	11-8	11-10	12-1
2 × 8	12.0	5-2	6-4	7-4	8-3	8-8	8-8	10-5	11-8	11-7	12-2	12-8	13-3	13-8	14-3	14-8	15-2	15-7	16-8	16-5	16-10	17-3	17-7	18-8	18-4	18-8	18-1	18-5	17-1	17-5
	18.0	4-6	5-8	6-4	7-1	7-8	8-5	8-8	8-8	10-1	10-7	11-8	11-8	11-11	12-4	12-8	13-1	13-8	13-10	14-3	14-7	14-11	15-3	15-7	15-11	16-3	16-8	16-10	17-1	17-5
	24.0	4-1	5-8	5-10	6-8	7-1	7-8	8-3	8-8	8-2	8-8	10-1	10-8	10-10	11-3	11-7	12-8	12-4	12-8	13-6	13-4	13-7	13-11	14-3	14-8	14-10	15-1	15-4	15-8	15-11
2 × 10	12.0	6-7	8-1	8-4	10-0	11-8	12-5	13-3	14-1	14-10	15-8	16-3	16-11	17-8	18-2	18-8	18-4	18-10	20-5	20-11	21-8	22-8	22-8	22-11	23-5	23-11	24-4	24-8	21-10	22-3
	18.0	5-8	7-8	8-1	8-1	8-11	10-8	11-8	12-2	12-10	13-5	14-1	14-8	15-2	15-8	16-3	16-8	17-3	17-8	18-2	18-7	18-8	18-5	18-10	20-3	20-8	21-1	21-8	21-10	22-3
	24.0	4-8	6-8	7-5	7-5	8-1	8-8	8-4	8-11	10-3	11-8	12-5	12-10	13-3	13-8	14-1	14-5	14-10	15-2	15-8	15-11	16-3	16-7	16-11	18-3	18-7	18-11	17-3	17-8	18-2
E	12.0	0.85	0.80	0.14	0.20	0.26	0.32	0.40	0.47	0.55	0.64	0.73	0.82	0.92	1.02	1.12	1.23	1.34	1.45	1.57	1.69	1.81	1.93	2.06	2.18	2.32	2.46	2.60	2.74	
	18.0	0.84	0.80	0.12	0.17	0.22	0.28	0.34	0.41	0.48	0.56	0.63	0.71	0.80	0.89	0.97	1.06	1.16	1.26	1.36	1.46	1.57	1.67	1.78	1.90	2.01	2.13	2.25	2.37	2.49
	24.0	0.84	0.87	0.11	0.15	0.20	0.25	0.31	0.37	0.44	0.51	0.58	0.65	0.73	0.81	0.89	0.97	1.06	1.15	1.24	1.33	1.42	1.53	1.63	1.73	1.84	1.94	2.05	2.16	2.28

NOTE: The required modulus of elasticity,  $E$ , in 1,000,000 pounds per square inch is shown at the bottom of this table, is limited to 2.6 million psi ( $17.92 \times 10^6$  kN/m<sup>2</sup>) and less, and is applicable to all lumber sizes shown. Spans are shown in feet-inches (1 foot = 304.8 mm, 1 inch = 25.4 mm) and are limited to 26 feet (7925 mm) and less.

**TABLE 23-V-R-11—RAFTERS WITH  $L/180$  DEFLECTION LIMITS**  
 The allowable bending stress ( $F_b$ ) and modulus of elasticity ( $E$ ) used in this table shall be from Tables 23-I-X-1 and 23-I-X-2 only.

Rafters Sizing (in)		Bending Design Value, $F_b$ (psi) ( $\times 0.00689$ kN/m <sup>2</sup> )																													
		$\times 25.4$ mm																													
		200	300	400	500	600	700	800	900	1000	1100	1200	1300	1400	1500	1600	1700	1800	1900	2000	2100	2200	2300	2400	2500	2600	2700	2800	2900	3000	
2 $\times$ 4	12.0	2-7	3-2	3-8	4-1	4-8	4-11	5-3	5-8	5-10	6-1	6-5	6-8	6-11	7-2	7-5	7-7	7-10	8-0	8-3	8-5	8-8	8-10	8-8	8-3	8-5	8-7	8-8	8-11	10-1	
	18.0	2-3	2-8	3-2	3-7	3-11	4-3	4-8	4-10	5-1	5-4	5-8	5-9	6-0	6-2	6-5	6-7	6-8	7-0	7-2	7-4	7-8	7-10	8-0	8-2	8-4	8-5	8-7	8-8	8-8	
	18.2	2-1	2-8	2-11	3-3	3-7	3-10	4-1	4-4	4-7	4-10	5-1	5-3	5-5	5-8	5-10	6-0	6-2	6-4	6-8	6-8	6-10	7-0	7-2	7-3	7-5	7-7	7-9	7-10	8-0	
	24.0	1-10	2-3	2-7	2-11	3-2	3-5	3-8	3-11	4-1	4-4	4-8	4-8	4-11	5-1	5-3	5-5	5-8	5-8	5-8	5-10	6-0	6-1	6-3	6-5	6-6	6-8	6-8	6-11	7-0	7-2
2 $\times$ 6	12.0	4-1	5-0	5-10	6-6	7-1	7-8	8-2	8-8	8-2	8-7	10-0	10-5	10-10	11-3	11-7	11-11	12-4	12-8	13-0	13-3	13-7	13-11	14-2	14-8	14-8	15-1	15-4	15-7	15-11	
	18.0	3-7	4-4	5-0	5-7	6-2	6-8	7-1	7-8	7-11	8-4	8-8	8-1	8-5	8-8	10-0	10-4	10-8	10-11	11-3	11-8	11-8	11-8	12-0	12-4	12-7	12-10	13-1	13-3	13-6	13-8
	18.2	3-3	4-0	4-7	5-1	5-7	6-1	6-6	6-10	7-3	7-7	7-11	8-3	8-7	8-11	8-2	8-5	8-8	10-0	10-3	10-6	10-8	11-0	11-3	11-5	11-8	11-11	12-2	12-4	12-7	
	24.0	2-11	3-7	4-1	4-7	5-0	5-5	5-10	6-2	6-6	6-10	7-1	7-5	7-8	7-11	8-2	8-5	8-8	8-11	8-2	8-2	8-5	8-7	8-10	10-0	10-3	10-5	10-8	10-10	11-0	11-3
2 $\times$ 8	12.0	5-5	6-7	7-8	8-7	9-4	10-1	10-10	11-0	12-1	12-8	13-3	13-8	14-4	14-10	15-3	15-9	16-3	16-8	17-1	17-8	17-11	18-4	18-8	18-1	18-8	18-10	20-3	20-7	20-11	
	18.0	4-8	5-8	6-7	7-5	8-1	8-8	9-4	9-11	10-8	11-0	11-8	11-11	12-5	12-10	13-3	13-8	14-0	14-5	14-10	15-2	15-8	15-10	16-3	16-7	16-10	17-2	17-8	17-10	18-1	
	18.2	4-2	5-3	6-0	6-8	7-5	8-0	8-7	9-1	9-7	10-0	10-6	10-11	11-4	11-8	12-1	12-5	12-10	13-2	13-6	13-10	14-2	14-8	14-10	15-1	15-5	15-8	16-8	16-8	16-7	
	24.0	3-10	4-8	5-5	6-0	6-7	7-2	7-8	8-1	8-7	9-0	9-4	9-8	10-1	10-8	10-10	11-2	11-8	11-8	11-8	12-1	12-5	12-8	12-11	13-3	13-8	13-8	14-4	14-4	14-7	14-10
2 $\times$ 10	12.0	6-11	8-5	9-8	10-11	11-11	12-11	13-8	14-8	15-5	16-2	16-11	17-7	18-3	18-11	19-8	20-1	20-8	21-3	21-10	22-4	22-10	23-5	23-11	24-5	24-10	25-4	25-10			
	18.0	6-8	7-4	8-5	9-5	10-4	11-2	11-11	12-8	13-4	14-0	14-8	15-3	15-10	16-4	16-11	17-5	17-11	18-5	18-11	18-4	18-10	20-3	20-8	21-1	21-8	21-11	22-4	22-8	23-1	
	18.2	5-5	6-8	7-8	8-7	9-5	10-2	10-11	11-7	12-2	12-8	13-4	13-11	14-5	14-11	15-5	15-11	16-4	16-10	17-3	17-8	18-1	18-8	18-11	19-3	19-8	20-0	20-5	20-8	21-1	
	24.0	4-11	6-0	6-11	7-8	8-5	9-1	9-8	10-4	10-11	11-5	11-11	12-5	12-11	13-4	13-8	14-2	14-8	15-8	15-5	15-10	16-2	16-8	16-11	17-3	17-7	17-11	18-3	18-7	18-11	
E	12.0	0.94	0.80	0.13	0.18	0.23	0.28	0.33	0.43	0.50	0.58	0.66	0.74	0.83	0.92	1.01	1.11	1.21	1.31	1.41	1.52	1.63	1.74	1.86	2.00	2.16	2.22	2.34	2.47	2.60	
	18.0	0.94	0.87	0.11	0.15	0.20	0.25	0.31	0.37	0.43	0.50	0.57	0.64	0.72	0.80	0.88	0.96	1.05	1.13	1.22	1.32	1.41	1.51	1.61	1.71	1.82	1.92	2.03	2.14	2.25	
	18.2	0.94	0.88	0.10	0.14	0.18	0.23	0.28	0.34	0.40	0.46	0.52	0.58	0.65	0.73	0.80	0.88	0.95	1.04	1.12	1.20	1.29	1.38	1.47	1.56	1.66	1.75	1.85	1.95	2.05	
	24.0	0.93	0.86	0.80	0.13	0.18	0.21	0.25	0.30	0.35	0.41	0.46	0.52	0.58	0.65	0.72	0.78	0.85	0.92	1.00	1.08	1.16	1.23	1.31	1.40	1.48	1.57	1.66	1.75	1.84	

NOTE: The required modulus of elasticity,  $E$ , in 1,000,000 pounds per square inch is shown at the bottom of this table, is limited to 2.6 million psi ( $17.92 \times 10^6$  kN/m<sup>2</sup>) and less, and is applicable to all lumber sizes shown. Spans are shown in feet-inches (1 foot = 304.8 mm, 1 inch = 25.4 mm) and are limited to 26 feet (7925 mm) and less.

**TABLE 23-V-R-12—RAFTERS WITH L/180 DEFLECTION LIMITS**

The allowable bending stress ( $F_b$ ) and modulus of elasticity ( $E$ ) used in this table shall be from Tables 23-I-X-1 and 23-I-X-2 only.

**DESIGN CRITERIA:**

Strength — Live load of 50 psf (2.40 kN/m<sup>2</sup>) plus dead load of 20 psf (0.96 kN/m<sup>2</sup>) determines the required bending design value.

Deflection — For 50 psf (2.40 kN/m<sup>2</sup>) live load.

Limited to span in inches (mm) divided by 180.

Rafter Size (in) (mm)		Bending Design Value, $F_b$ (psi) (× 0.00689 kN/m <sup>2</sup> )																													
		× 25.4 mm																													
		200	300	400	500	600	700	800	900	1000	1100	1200	1300	1400	1500	1600	1700	1800	1900	2000	2100	2200	2300	2400	2500	2600	2700	2800	2900	3000	
2 × 4	12.0	2.5	2:11	3:5	3:10	4:2	4:8	4:10	5:1	5:5	5:8	5:11	6:2	6:5	6:7	6:10	7:0	7:3	7:5	7:8	7:10	8:0	8:2	8:4	8:8	8:8	8:10	8:8	8:2	8:4	
	18.0	2:1	2:7	2:11	3:4	3:7	3:11	4:2	4:5	4:8	4:11	5:1	5:4	5:8	5:8	5:11	6:1	6:3	6:5	6:7	6:8	6:11	7:1	7:3	7:5	7:8	7:8	7:10	8:0	8:1	
	18.2	1:11	2:4	2:8	3:0	3:4	3:7	3:10	4:1	4:3	4:6	4:8	4:10	5:1	5:3	5:5	5:7	5:8	5:11	6:0	6:2	6:4	6:8	6:7	6:8	6:11	7:0	7:2	7:3	7:5	
	24.0	1:8	2:1	2:5	2:8	2:11	3:2	3:5	3:7	3:10	4:0	4:2	4:4	4:8	4:8	4:10	5:0	5:1	5:3	5:5	5:8	5:8	5:11	6:0	6:0	6:11	6:8	6:5	6:8	6:7	
2 × 6	12.0	3:10	4:8	5:4	6:0	6:7	7:1	7:7	8:1	8:8	8:11	8:4	8:8	10:0	10:5	10:8	11:1	11:5	11:8	12:0	12:4	12:7	12:10	13:2	13:5	13:8	13:11	14:2	14:5	14:8	
	18.0	3:3	4:0	4:8	5:2	5:8	6:2	6:7	7:0	7:4	7:8	8:1	8:5	8:8	8:8	8:4	9:7	9:10	10:2	10:5	10:8	10:11	11:2	11:5	11:7	11:10	12:1	12:4	12:8	12:8	
	18.2	3:0	3:8	4:3	4:8	5:2	5:7	6:0	6:4	6:8	7:0	7:4	7:8	7:11	8:3	8:6	8:8	9:0	9:3	9:8	9:8	9:11	10:2	10:5	10:7	10:10	11:0	11:3	11:5	11:7	
	24.0	2:8	3:3	3:10	4:3	4:8	5:0	5:4	5:8	6:0	6:4	6:7	6:10	7:1	7:4	7:7	7:10	8:1	8:3	8:6	8:8	9:1	9:1	9:11	9:1	9:4	9:6	9:8	9:10	10:0	10:5
2 × 8	12.0	5:0	6:2	7:1	7:11	8:8	8:4	10:0	10:7	11:2	11:8	12:3	12:8	13:3	13:8	14:2	14:7	15:0	15:5	15:10	16:3	16:7	17:0	17:4	17:8	18:8	18:5	18:8	18:1	18:5	
	18.0	4:4	5:4	6:2	6:10	7:8	8:1	8:8	9:2	9:8	10:2	10:7	11:1	11:8	11:10	12:3	12:8	13:0	13:4	13:8	14:0	14:4	14:8	15:0	15:4	15:7	15:11	16:3	16:6	16:8	
	18.2	3:11	4:10	5:7	6:3	6:10	7:5	7:11	8:5	8:10	9:3	9:8	10:1	10:6	10:10	11:2	11:8	11:10	12:2	12:6	12:10	13:1	13:5	13:8	14:0	14:3	14:8	14:10	15:1	15:4	
	24.0	3:8	4:4	5:0	5:7	6:2	6:7	7:1	7:8	7:11	8:4	8:8	9:0	9:4	9:8	10:0	10:4	10:7	10:11	11:2	11:6	11:8	12:0	12:3	12:6	12:8	13:0	13:3	13:6	13:8	
2 × 10	12.0	6:5	7:10	8:0	10:1	11:1	11:11	12:8	13:8	14:3	15:0	15:8	16:3	16:11	17:0	18:1	18:7	19:2	19:8	20:2	20:8	21:2	21:8	22:1	22:7	23:0	23:5	23:11	24:4	24:8	
	18.0	5:8	6:8	7:10	8:0	8:7	10:4	11:1	11:8	12:4	13:0	13:8	14:1	14:8	15:2	15:8	16:1	16:7	17:0	17:6	17:11	18:4	18:8	18:2	19:7	19:11	20:4	20:8	21:1	21:5	
	18.2	5:1	6:2	7:2	8:0	8:8	8:5	10:1	10:8	11:3	11:10	12:4	12:10	13:4	13:10	14:3	14:8	15:2	15:7	15:11	16:4	16:8	17:1	17:8	17:10	18:2	18:8	19:11	19:8	19:7	
	24.0	4:8	5:8	6:5	7:2	7:10	8:5	8:8	9:7	10:1	10:7	11:1	11:8	11:11	12:4	12:8	13:2	13:8	13:11	14:3	14:8	15:0	15:4	15:8	15:11	16:3	16:7	16:11	17:2	17:4	
E	12.0	0.94	0.90	0.13	0.19	0.23	0.29	0.35	0.42	0.50	0.57	0.65	0.74	0.82	0.91	1.00	1.10	1.20	1.30	1.40	1.51	1.62	1.73	1.84	1.90	2.00	2.08	2.22	2.32	2.45	2.58
	18.0	0.94	0.87	0.11	0.15	0.20	0.25	0.31	0.37	0.43	0.50	0.58	0.64	0.71	0.79	0.87	0.95	1.04	1.12	1.21	1.31	1.40	1.50	1.60	1.70	1.81	1.91	2.12	2.23		
	18.2	0.94	0.86	0.10	0.14	0.18	0.23	0.28	0.33	0.38	0.45	0.52	0.58	0.65	0.72	0.79	0.87	0.95	1.03	1.11	1.19	1.28	1.37	1.46	1.55	1.64	1.74	1.94	2.04		
	24.0	0.83	0.80	0.09	0.12	0.16	0.21	0.25	0.30	0.35	0.40	0.46	0.52	0.58	0.64	0.71	0.78	0.85	0.92	0.99	1.07	1.14	1.22	1.30	1.38	1.47	1.58	1.64	1.78	1.82	

NOTE: The required modulus of elasticity,  $E$ , in 1,000,000 pounds per square inch is shown at the bottom of this table, is limited to 2.6 million psi ( $17.92 \times 10^6$  kN/m<sup>2</sup>) and less, and is applicable to all lumber sizes shown. Spans are shown in feet-inches (1 foot = 304.8 mm, 1 inch = 25.4 mm) and are limited to 26 feet (7925 mm) and less.

**Division VI—DESIGN STANDARD FOR PLANK-AND-BEAM FRAMING**

**Based on Wood Construction Data No. 4 (1970)  
of the American Forest and Paper Association**

**SECTION 2356 — SCOPE**

This division covers plank-and-beam construction under the provisions of this code and is subject to the regulations of Division I. Tables in this division are for use where moderate uniform loads occur and are not applicable for concentrated loads such as partitions, bathtubs, refrigerators, etc. See also Table 23-I-U of Division I.

**SECTION 2357 — DEFINITION**

The plank-and-beam structural floor or roof system consists of a plank subfloor or roof decking with supporting beams spaced a maximum of 8 feet (2438 mm) on center.

**SECTION 2358 — DESIGN**

The load strength and deflection requirements for 2-inch (51 mm) planks and beams are set forth in Tables 23-VI-A, 23-VI-B, 23-VI-C and 23-VI-D.

The allowable unit stress  $f$  appropriate for each grade and species of lumber is set forth in Tables 23-I-A-1, 23-I-A-2, 23-I-A-4 and 23-I-A-5.

**TABLE 23-VI-A—2-INCH (51 mm) PLANK—REQUIRED MINIMUM *f* AND *E* LIVE LOAD: 20, 30 AND 40 POUNDS PER SQUARE FOOT (0.96, 1.44 and 1.92 kN/m<sup>2</sup>) WITHOUT PLASTERED CEILING BELOW**

PLANK SPAN (feet)	LIVE LOAD (pounds per square foot)	DEFLECTION LIMITATION	TYPE A		TYPE B		TYPE C		TYPE D	
			<i>f</i> psi	<i>E</i> psi	<i>f</i> psi	<i>E</i> psi	<i>f</i> psi	<i>E</i> psi	<i>f</i> psi	<i>E</i> psi
× 304.8 for mm	× 0.0479 for kN/m <sup>2</sup>		× 0.00689 for N/mm <sup>2</sup>							
6	20	<i>l</i> / 240	360	576,000	360	239,000	288	305,000	360	408,000
		<i>l</i> / 360	360	864,000	360	359,000	288	457,000	360	611,000
	30	<i>l</i> / 240	480	864,000	480	359,000	384	457,000	480	611,000
		<i>l</i> / 360	480	1,296,000	480	538,000	384	685,000	480	917,000
	40	<i>l</i> / 240	600	1,152,000	600	478,000	480	609,000	600	815,000
		<i>l</i> / 360	600	1,728,000	600	717,000	480	914,000	600	1,223,000
7	20	<i>l</i> / 240	490	915,000	490	380,000	392	484,000	490	647,000
		<i>l</i> / 360	490	1,372,000	490	570,000	392	726,000	490	971,000
	30	<i>l</i> / 240	653	1,372,000	653	570,000	522	726,000	653	971,000
		<i>l</i> / 360	653	2,058,000	653	854,000	522	1,088,000	653	1,456,000
	40	<i>l</i> / 240	817	1,829,000	817	759,000	653	968,000	817	1,294,000
		<i>l</i> / 360	817	2,744,000	817	1,139,000	653	1,451,000	817	1,941,000

8	20	l 240	640	1,365,000	640	567,000	512	722,000	640	966,000
		l 360	640	2,048,000	640	850,000	512	1,083,000	640	1,449,000
	30	l 240	853	2,048,000	853	850,000	682	1,083,000	853	1,449,000
		l 360	853	3,072,000	853	1,275,000	682	1,625,000	853	2,174,000
	40	l 240	1,067	2,731,000	1067	1,134,000	853	1,444,000	1,067	1,932,000
		l 360	1,067	4,096,000	1067	1,700,000	853	2,166,000	1,067	2,898,000

1994 UNIFORM BUILDING CODE

23-VI-A

**TABLE 23-VI-B—ROOF BEAMS—LIVE LOAD 20 POUNDS PER SQUARE FOOT (0.96 kN/m<sup>2</sup>)—  
DEFLECTION LIMITATION L/240 (not for support of plaster)**

SPAN OF BEAM (feet)	NOMINAL SIZE OF BEAM	MINIMUM <i>f</i> AND <i>E</i> IN PSI FOR BEAMS SPACED:					
		6'-0" (1829 mm)		7'-0" (2134 mm)		8'-0" (2438 mm)	
		<i>f</i>	<i>E</i>	<i>f</i>	<i>E</i>	<i>f</i>	<i>E</i>
× 304.8 for mm	× 25.4 for mm	× 0.00689 for N/mm <sup>2</sup>					
10	2-3 × 6	1,070	780,000	1,250	910,000	1,430	1,040,000
	1-3 × 8	1,235	680,000	1,440	794,000	1,645	906,000
	2-2 × 8	1,030	570,000	1,200	665,000	1,370	760,000
	1-4 × 8	880	485,000	1,030	566,000	1,175	646,000
	3-2 × 8	685	380,000	800	443,000	915	506,000
	2-3 × 8	615	340,000	720	397,000	820	453,000
	2-2 × 10	630	273,000	735	219,000	840	364,000
11	2-3 × 6	1,295	1,037,000	1,510	121,000	1,730	1,382,000
	1-3 × 8	1,490	905,000	1,740	1,056,000	1,990	1,206,000
	2-2 × 8	1,245	754,000	1,450	880,000	1,660	1,005,000
	1-4 × 8	1,065	647,000	1,245	755,000	1,420	862,000
	3-2 × 8	830	503,000	970	587,000	1,105	670,000
	2-3 × 8	745	453,000	870	529,000	995	604,000
	2-2 × 10	765	363,000	890	424,000	1,020	484,000
12	2-3 × 6	1,545	1,346,000	1,800	1,571,000	2,060	1,794,000
	1-3 × 8	1,775	1,175,000	2,070	1,371,000	2,370	1,566,000
	2-2 × 8	1,480	980,000	1,725	1,144,000	1,970	1,306,000
	1-4 × 8	1,270	840,000	1,480	980,000	1,690	1,120,000
	3-2 × 8	985	653,000	1,150	762,000	1,315	870,000
	2-3 × 8	890	588,000	1,035	686,000	1,185	784,000
	1-6 × 8	755	483,000	880	564,000	1,005	644,000
	2-2 × 10	910	472,000	1,060	551,000	1,210	629,000
	1-3 × 10	1,090	566,000	1,275	660,000	1,455	754,000
	13	2-3 × 6	1,815	1,711,000	2,110	1,997,000	2,415
1-3 × 8		2,085	1,494,000	2,430	1,743,000	2,780	1,991,000
2-2 × 8		1,740	1,245,000	2,025	1,453,000	2,315	1,660,000
1-4 × 8		1,490	1,067,000	1,735	1,245,000	1,985	1,422,000
3-2 × 8		1,160	830,000	1,350	969,000	1,545	1,106,000
2-3 × 8		1,045	747,000	1,215	872,000	1,390	996,000
1-6 × 8		885	614,000	1,040	716,000	1,185	818,000
2-2 × 10		1,070	600,000	1,245	700,000	1,420	800,000
1-3 × 10		1,280	719,000	1,495	839,000	1,710	958,000
14		2-2 × 8	2,015	1,555,000	2,350	1,815,000	2,685
	3-2 × 8	1,340	1,037,000	1,570	1,210,000	1,790	1,382,000
	2-3 × 8	1,210	933,000	1,410	1,089,000	1,610	1,244,000
	1-6 × 8	1,025	766,000	1,200	894,000	1,370	1,021,000
	1-3 × 10	1,485	899,000	1,730	1,049,000	1,980	1,198,000
	2-2 × 10	1,235	749,000	1,445	874,000	1,650	998,000
	1-4 × 10	1,060	642,000	1,240	749,000	1,415	856,000
	3-2 × 10	825	499,000	965	582,000	1,100	665,000
	2-3 × 10	740	449,000	865	524,000	990	598,000
15	3-2 × 8	1,540	1,275,000	1,800	1,488,000	2,055	1,699,000
	2-3 × 8	1,390	1,148,000	1,620	1,340,000	1,850	1,530,000
	1-6 × 8	1,180	943,000	1,375	1,100,000	1,570	1,257,000
	1-3 × 10	1,705	1,105,000	1,990	1,289,000	2,270	1,473,000
	2-2 × 10	1,420	921,000	1,660	1,075,000	1,895	1,228,000
	1-4 × 10	1,220	789,000	1,420	921,000	1,625	1,052,000
	3-2 × 10	950	614,000	1,105	717,000	1,265	818,000
	2-3 × 10	850	553,000	995	645,000	1,135	737,000
	1-6 × 10	735	464,000	855	541,000	980	618,000
	4-2 × 10	710	461,000	830	538,000	945	614,000
	2-2 × 10	960	512,000	1,120	597,000	1,280	682,000

**TABLE 23-VI-C—ROOF BEAMS—LIVE LOAD 30 POUNDS PER SQUARE FOOT (1.44 kN/m<sup>2</sup>)—  
DEFLECTION LIMITATION L/240 (not for support of plaster)**

SPAN OF BEAM (feet)	NOMINAL SIZE OF BEAM	MINIMUM I AND E IN PSI FOR BEAMS SPACED:					
		6'-0" (1829 mm)		7'-0" (2134 mm)		8'-0" (2438 mm)	
		f	E	f	E	f	E
× 304.8 for mm	× 25.4 for mm	× 0.00689 for N/mm <sup>2</sup>					
10	2-3 × 6	1,430	1,170,000	1,670	1,365,000	1,905	1,560,000
	1-3 × 8	1,645	1,020,000	1,920	1,190,000	2,195	1,360,000
	1-4 × 8	1,175	727,000	1,370	848,000	1,565	969,000
	3-2 × 8	915	570,000	1,070	665,000	1,220	760,000
	2-3 × 8	820	510,000	955	595,000	1,095	680,000
	2-4 × 8	590	364,000	690	425,000	785	485,000
	2-2 × 10	840	409,000	980	477,000	1,120	545,000
11	2-3 × 6	1,725	1,555,000	2,015	1,815,000	2,300	2,073,000
	1-3 × 8	1,990	1,357,000	2,320	1,584,000	2,655	1,809,000
	1-4 × 8	1,420	970,000	1,660	1,132,000	1,895	1,293,000
	3-2 × 8	1,105	754,000	1,290	880,000	1,475	1,005,000
	2-3 × 8	995	679,000	1,160	792,000	1,325	905,000
	2-4 × 8	710	485,000	830	566,000	945	646,000
	2-2 × 10	1,020	544,000	1,190	635,000	1,360	725,000
12	1-4 × 8	1,690	1,260,000	1,970	1,470,000	2,255	1,679,000
	3-2 × 8	1,315	979,000	1,535	1,142,000	1,755	1,305,000
	2-3 × 8	1,185	882,000	1,385	1,029,000	1,580	1,176,000
	2-4 × 8	845	630,000	985	735,000	1,125	840,000
	1-6 × 8	1,005	724,000	1,175	845,000	1,340	965,000
	2-2 × 10	1,210	708,000	1,410	826,000	1,615	944,000
	3-2 × 10	810	472,000	945	551,000	1,080	629,000
2-3 × 10	725	424,000	845	495,000	965	565,000	
13	1-4 × 8	1,985	1,600,000	2,315	1,867,000	2,645	2,133,000
	3-2 × 8	1,545	1,245,000	1,805	1,453,000	2,060	1,659,000
	2-3 × 8	1,390	1,120,000	1,620	1,307,000	1,855	1,493,000
	2-4 × 8	990	801,000	1,155	935,000	1,320	1,068,000
	1-6 × 8	1,180	921,000	1,375	1,075,000	1,575	1,228,000
	2-2 × 10	1,425	900,000	1,665	1,050,000	1,900	1,200,000
	3-2 × 10	950	600,000	1,110	700,000	1,265	800,000
	2-3 × 10	855	540,000	1,000	630,000	1,140	720,000
	1-4 × 10	1,220	923,000	1,425	1,079,000	1,625	1,230,000
14	3-2 × 8	1,790	1,555,000	2,090	1,815,000	2,385	2,073,000
	2-3 × 8	1,610	1,400,000	1,880	1,634,000	2,145	1,866,000
	2-4 × 8	1,150	1,000,000	1,340	1,167,000	1,535	1,333,000
	1-6 × 8	1,370	1,149,000	1,600	1,341,000	1,825	1,532,000
	2-2 × 10	1,650	1,123,000	1,925	1,310,000	2,200	1,497,000
	3-2 × 10	1,100	748,000	1,285	873,000	1,465	997,000
	2-3 × 10	990	673,000	1,155	785,000	1,320	897,000
	1-4 × 10	1,415	963,000	1,650	1,124,000	1,885	1,283,000
	1-6 × 10	915	943,000	1,070	1,100,000	1,220	1,257,000
	2-4 × 10	705	481,000	825	561,000	940	641,000
15	2-4 × 8	1,320	1,230,000	1,540	1,435,000	1,760	1,640,000
	1-6 × 8	1,570	1,414,000	1,830	1,650,000	2,095	1,885,000
	2-2 × 10	1,895	1,381,000	2,210	1,612,000	2,525	1,841,000
	3-2 × 10	1,260	921,000	1,470	1,075,000	1,680	1,228,000
	2-3 × 10	1,135	829,000	1,325	967,000	1,515	1,105,000
	1-4 × 10	1,620	1,183,000	1,890	1,380,000	2,160	1,577,000
	1-6 × 10	980	696,000	1,145	812,000	1,305	928,000
	2-4 × 10	810	592,000	945	691,000	1,080	789,000
	4-2 × 10	945	691,000	1,105	806,000	1,260	921,000
	1-8 × 10	720	510,000	840	595,000	960	680,000
	2-2 × 12	1,280	768,000	1,495	896,000	1,705	1,024,000
	1-4 × 12	1,095	658,000	1,280	768,000	1,460	877,000

**TABLE 23-VI-D—ROOF AND FLOOR BEAMS—LIVE LOAD 40 POUNDS PER SQUARE FOOT (1.92 kN/m<sup>2</sup>)—DEFLECTION LIMITATION L/360 (not for support of plaster)**

SPAN OF BEAM (feet)	NOMINAL SIZE OF BEAM	MINIMUM I AND E IN PSI FOR BEAMS SPACED:					
		6'-0" (1829 mm)		7'-0" (2134 mm)		8'-0" (2438 mm)	
		f	E	f	E	f	E
× 304.8 for mm	× 25.4 for mm	× 0.00689 for N/mm <sup>2</sup>					
10	1-3 × 8	2,055	1,700,000	2,400	1,984,000	2,740	2,266,000
	2-2 × 8	1,710	1,417,000	1,995	1,654,000	2,280	1,889,000
	1-4 × 8	1,470	1,211,000	1,715	1,413,000	1,960	1,614,000
	1-6 × 8	875	697,000	1,020	813,000	1,165	929,000
	2-2 × 10	1,050	681,000	1,225	795,000	1,400	908,000
	1-3 × 10	1,260	819,000	1,470	956,000	1,680	1,092,000
	1-4 × 10	900	585,000	1,050	683,000	1,200	780,000
11	2-2 × 8	2,070	1,886,000	2,415	2,201,000	2,760	2,514,000
	1-4 × 8	1,775	1,616,000	2,070	1,886,000	2,365	2,154,000
	1-6 × 8	1,055	929,000	1,230	1,084,000	1,405	1,238,000
	2-2 × 10	1,275	906,000	1,490	1,057,000	1,700	1,208,000
	1-3 × 10	1,575	1,090,000	1,780	1,272,000	2,030	1,453,000
	1-4 × 10	1,090	779,000	1,270	909,000	1,455	1,038,000
	3-2 × 10	850	605,000	990	706,000	1,135	806,000
12	1-6 × 8	1,255	1,206,000	1,465	1,407,000	1,670	1,607,000
	3-2 × 8	1,645	1,631,000	1,920	1,903,000	2,190	2,174,000
	2-2 × 10	1,510	1,180,000	1,760	1,377,000	2,010	1,573,000
	1-3 × 10	1,820	1,415,000	2,125	1,651,000	2,425	1,886,000
	1-4 × 10	1,300	1,010,000	1,515	1,179,000	1,735	1,346,000
	3-2 × 10	1,010	786,000	1,180	917,000	1,345	1,048,000
	2-3 × 10	905	706,000	1,055	824,000	1,205	941,000
	1-6 × 10	785	594,000	915	693,000	1,045	792,000
	2-4 × 10	650	505,000	760	589,000	865	673,000
13	1-6 × 8	1,475	1,535,000	1,720	1,791,000	1,965	2,046,000
	2-3 × 8	1,735	1,866,000	2,025	2,178,000	2,315	2,487,000
	2-4 × 8	1,235	1,335,000	1,440	1,558,000	1,645	1,779,000
	3-2 × 10	1,185	1,000,000	1,380	1,167,000	1,580	1,333,000
	2-2 × 10	1,780	1,500,000	2,075	1,750,000	2,370	2,000,000
	1-3 × 10	2,130	1,799,000	2,485	2,099,000	2,840	2,398,000
	2-3 × 10	1,070	900,000	1,250	1,050,000	1,425	1,200,000
	1-4 × 10	1,525	1,537,000	1,780	1,794,000	2,035	2,049,000
	2-4 × 10	760	642,000	890	749,000	1,015	856,000
	14	2-4 × 8	1,435	1,666,000	1,675	1,944,000	1,915
3-2 × 10		1,375	1,246,000	1,605	1,454,000	1,830	1,661,000
2-3 × 10		1,235	1,121,000	1,440	1,308,000	1,645	1,494,000
1-4 × 10		1,770	1,605,000	2,065	1,873,000	2,360	2,139,000
2-4 × 10		880	801,000	1,025	935,000	1,175	1,068,000
3-3 × 10		825	749,000	960	874,000	1,100	998,000
1-6 × 10		1,145	1,571,000	1,335	1,833,000	1,525	2,094,000
1-8 × 10		780	691,000	910	806,000	1,040	921,000
4-2 × 10		1,030	936,000	1,200	1,092,000	1,375	1,248,000
2-2 × 12		1,395	1,040,000	1,630	1,214,000	1,860	1,386,000
15	3-2 × 10	1,575	1,535,000	1,840	1,791,000	2,100	2,046,000
	2-3 × 10	1,420	1,381,000	1,655	1,612,000	1,890	1,841,000
	2-4 × 10	1,010	986,000	1,175	1,151,000	1,345	1,314,000
	3-3 × 10	945	921,000	1,100	1,075,000	1,260	1,228,000
	1-6 × 10	1,225	1,160,000	1,430	1,354,000	1,635	1,546,000
	1-8 × 10	900	850,000	1,050	992,000	1,200	1,133,000
	4-2 × 10	1,180	1,151,000	1,375	1,343,000	1,575	1,534,000
	2-2 × 12	1,600	1,280,000	1,865	1,494,000	2,130	1,706,000
	3-2 × 12	1,065	854,000	1,240	997,000	1,420	1,138,000
	1-3 × 12	1,920	1,536,000	2,240	1,792,000	2,560	2,047,000
	4-2 × 12	800	640,000	935	747,000	1,065	853,000
	2-3 × 12	960	767,000	1,120	895,000	1,280	1,022,000

**Division VII—DESIGN STANDARD FOR TEMPERATURE EFFECTS**  
**Based on National Design Specification for Wood Construction (1991),**  
**including the 1991 Supplement of the American Forest and Paper Association**

**SECTION 2359 — SCOPE**

This division covers adjustments to design values for wood structural members which are exposed by manufacturing and equipment processes to prolonged elevated temperatures between 100°F. and 150°F. (37.8°C. and 65.6°C.). This division does not apply to wood members exposed to the normal range of climatic temperatures ordinarily encountered in buildings.

**SECTION 2360 — WORKING STRESS**

Wood members heated to temperatures 100°F. and 150°F. (37.8°C. and 65.6°C.) for extended periods of time shall have the design values adjusted. The average factors given in Table 23-VII-A shall be used in making such adjustments. Tabulated adjustments are for immediate temperature effects.

**TABLE 23-VII-A—TEMPERATURE ADJUSTMENT FACTORS**

DESIGN VALUES	IN-SERVICE MOISTURE CONDITIONS	100°F. < T ≤ 125°F. (37.8°C. < T ≤ 51.7°C.)	125°F. < T ≤ 150°F. (51.7°C. < T ≤ 65.6°C.)
<i>F<sub>t</sub></i> , <i>E</i>	Wet or dry	0.9	0.9
<i>F<sub>b</sub></i> , <i>F<sub>v</sub></i> , <i>F<sub>c</sub></i> , <i>F<sub>c</sub></i> and connections	Dry Wet	0.8 0.7	0.7 0.5

**Division VIII—DESIGN STANDARD FOR DESIGN PROVISIONS  
FOR SAWN LUMBER**

**Based on the National Design Specification, 1991 Edition**

**SECTION 2361 — SCOPE**

This division covers design practices of sawn lumber which are applicable to glued-laminated timber and similar solid-wood products. Design practices specified herein are acceptable under the requirements specified in Division I.

**SECTION 2362 — BEARING ON END GRAIN**

Allowable design values for end grain in bearing  $F_g$  are listed in Table 23-VIII-A. Values apply to the net area in bearing. Unit stresses in bearing on the end grain of wood, for parallel to grain, shall not exceed these design values.

When the stress in end-grain bearing exceeds 75 percent of the values provided in this table, the bearing shall be on a metal plate or strap or on other durable, rigid, homogeneous material of adequate strength.

The design values for end-grain bearing apply to end-to-end bearing of compression members, provided there is adequate lateral support and the end cuts are accurately squared and parallel. When a rigid insert is required, it shall be of not less than a 20 gage [0.036 inch (0.91 mm) (No. 20 galvanized sheet gage)] metal, or equivalent, inserted with a snug fit between abutting ends.

Where the load at bearing is at an angle to grain, the maximum bearing value shall be determined by the Hankinson formula, using the design for end-grain bearing, parallel to grain in Table 23-VIII-A and design values in compression perpendicular to grain in Tables 23-I-A-1, 23-I-A-2, 23-I-A-3, 23-I-A-4, 23-I-A-5 and 23-I-A-6.

**SECTION 2363 — SLENDERNESS FACTOR AND FLEXURAL STRESS**

Where the depth of a bending member exceeds its breadth, lateral support shall be provided as specified in Section 2304.3.6 and the allowable design value modified in accordance with the following sections.

**2363.1 Slenderness Factor.** The slenderness factor for a bending member shall be calculated by the following formula:

$$R_B = \sqrt{\frac{l_e d}{b^2}}$$

where  $l_e$  is determined as follows:

EFFECTIVE LENGTH, $l_e$ , FOR BENDING MEMBERS		
Cantilever <sup>1</sup>		
	when $l_u/d < 7$	when $l_u/d > 7$
Uniformly distributed load	$l_e = 1.33 l_u$	$l_e = 0.90 l_u + 3d$
Concentrated load at unsupported end	$l_e = 1.87 l_u$	$l_e = 1.44 l_u + 3d$
Single Span Beam <sup>1</sup>		
	when $l_u/d < 7$	when $l_u/d > 7$
Uniformly distributed load	$l_e = 2.06 l_u$	$l_e = 1.63 l_u + 3d$
Concentrated load at center with no intermediate lateral support	$l_e = 1.80 l_u$	$l_e = 1.37 l_u + 3d$
Concentrated load at center with lateral support at center		$l_e = 1.11 l_u$
Two equal concentrated loads at $1/3$ points with lateral support at $1/3$ points		$l_e = 1.68 l_u$
Three equal concentrated loads at $1/4$ points with lateral support at $1/4$ points		$l_e = 1.54 l_u$
Four equal concentrated loads at $1/5$ points with lateral support at $1/5$ points		$l_e = 1.68 l_u$
Five equal concentrated loads at $1/6$ points with lateral support at $1/6$ points		$l_e = 1.73 l_u$
Six equal concentrated loads at $1/7$ points with lateral support at $1/7$ points		$l_e = 1.78 l_u$
Seven or more equal concentrated loads, evenly spaced, with lateral support at points of load application		$l_e = 1.84 l_u$
Equal end moments		$l_e = 1.84 l_u$

<sup>1</sup>For single span or cantilever bending members with loading conditions not specified above.

$$\begin{array}{ll}
 l_e = 2.06 l_u & \text{when } l_u/d < 7 \\
 l_e = 1.63 l_u + 3d & \text{when } 7 \leq l_u/d \leq 14.3 \\
 l_e = 1.84 l_u & \text{when } l_u/d > 14.3
 \end{array}$$

When the compression edge of a bending member is supported throughout its length to prevent its lateral displacement and the ends at points of bearing have lateral support to prevent rotation, the unsupported length  $l_u$  may be taken as zero.

When lateral support is provided to prevent rotation at the points of end bearing but no other lateral support is provided throughout the length of the bending member, the unsupported length  $l_u$  is the distance between such points of end bearing or the length of a cantilever.

When a bending member is provided with lateral support to prevent rotational or lateral displacement at intermediate points as well as at the ends, the unsupported length  $l_u$  is the distance between such points of intermediate lateral support.

The slenderness factor  $R_B$  shall not exceed 50.

**2363.2 Allowable Stresses.** The design values for extreme fiber in bending,  $F'_b$ , and modulus of elasticity,  $E$ , used in the following formulae shall be modified in accordance with the provisions of Section 2304.3, except that the modification for size factor shall not apply to  $f_b$ .

Design value for extreme fiber in bending adjusted for slenderness factor  $F'_b$  obtained from the following formula:

$$F'_b = F_b^* \left\{ \frac{1 + (F_{bE}/F_b^*)}{1.9} - \sqrt{\left[ \frac{1 + (F_{bE}/F_b^*)}{1.9} \right]^2 - \frac{F_{bE}/F_b^*}{.95}} \right\}$$

**WHERE:**

$F_b^*$  = tabulated bending design value multiplied by all applicable modification factors except the size factor as specified in Section 2304.3 and Tables 23-I-A-1, 23-I-A-2, 23-I-A-4 and 23-I-A-5, and the volume factor as specified in Section 2312.

$$F_{bE} = \frac{K_{bE} E'}{R_B^2}$$

$K_{bE} = 0.438$  for visually graded lumber.

$K_{bE} = 0.609$  for products such as machine stress-rated lumber and glued-laminated timber.

Members subjected to flexure about both principal axes (biaxial bending) shall be designed in accordance with Section 2308.2.

### SECTION 2364 — HORIZONTAL SHEAR

Design shear in sawn lumber bending members shall be determined in accordance with Section 2306.3 or by the following provisions:

**EXCEPTION:** These provisions and the horizontal shear stress values therein do not apply when designing for horizontal shear in notched beams, joints, and beams supported by fastenings.

For continuous or cantilevered bending members of sawn lumber 2 inches to 4 inches (51 mm to 102 mm) (nominal) in thickness, the unit horizontal shear stress,  $f_v$ , at any cross section which is five times or more the depth (actual) from the member end shall not exceed two times the shear design values,  $F_v$ , given in Tables 23-I-A-1, 23-I-A-2, 23-I-A-3, 23-I-A-4, 23-I-A-5 and 23-I-A-6. For southern pine, this shear stress shall not exceed [2 x 85 psi (0.586 N/mm<sup>2</sup>)] for lumber S-green, [2 x 90 psi (0.621 N/mm<sup>2</sup>)] for lumber S-dry, or [2 x 95 psi (0.655 N/mm<sup>2</sup>)] for lumber KD-15. For redwood and yellow poplar, this shear stress shall not exceed [2 x 80 psi (0.552 N/mm<sup>2</sup>)] and [2 x 75 psi (0.517 N/mm<sup>2</sup>)], respectively. Shear design values,  $F_v$ , or equivalent values in this section are subject to modification in accordance with Section 2304.3, except for Note 7, Tables 23-I-A-1, 23-I-A-2 and 23-I-A-3.

In the stress grades of sawn lumber, allowances for checks, end splits and shakes have been included in the shear design values in Tables 23-I-A-1, 23-I-A-2, 23-I-A-3, 23-I-A-4, 23-I-A-5 and 23-I-A-6. For such members, the procedures of Section 2306.3 do not indicate the actual horizontal shear resistance because of the redistribution of shear stress that occurs in checked beams.

Thus, for a sawn lumber bending member which does not qualify under Item 5 below, the shear force,  $V$ , may be determined in accordance with Items 1 and 2 below, and the limiting design shear stress value in accordance with Items 3 and 4 below:

1. The design shear force is calculated as in Item 5, except that if there is a single moving load or one moving load that is considerably larger than any of the others, that load is placed at distances from each support equal to three times the depth of the bending member or at the quarter points, whichever is closer. Other loads are kept in their normal relation, and loads within a distance from supports equal to the depth of the bending member are neglected. The procedure in Item 2 shall be used when there are two or more moving loads of about equal weight and in proximity.

2. In lieu of the simplified procedure in Item 1 above, the design shear force may be determined by the following formulas:

For uniformly distributed load:

$$V = \frac{W}{2} \left( 1 - \frac{2d}{l_c} \right) C_v$$

For concentrated load:

$$V = \frac{P (l_c - x) (x/d)^2}{l_c [2 + (x/d)^2]}$$

Where  $C_v = 0.95 + \frac{\sqrt{l_c/d}}{250} - 1.32 (d/l_c) + 11.5 (d/l_c)^3$

The factor  $C_v$  shall not exceed one.

For a combination of concentrated loads,  $V$  is the sum  $V_1 + V_2 + \dots + V_n$  resulting from each such load at its distance  $x_1, x_2, \dots, x_n$  from the reaction. The load combination should be placed in that position which provides the maximum value for  $V$ .

3. The methods set forth in Items 1 and 2 for determining design shear force,  $V$ , shall not result in horizontal shear stress,  $f_v$ , when calculated as in Section 2306.3, that exceeds the shear design values,  $F_v$ , published in Tables 23-I-A-1, 23-I-A-2, 23-I-A-3, 23-I-A-4, 23-I-A-5 and 23-I-A-6, and modified in accordance with Section 2304.3, and such other sections as may apply (but excepting Note 7 of Tables 23-I-A-1, 23-I-A-2 and 23-I-A-4). For southern pine, the design value in shear shall not exceed 85 psi (0.586 N/mm<sup>2</sup>) for lumber S-green, 90 psi (0.621 N/mm<sup>2</sup>) for lumber S-dry, or 95 psi (0.655 N/mm<sup>2</sup>) for lumber KD-15. For California redwood and yellow poplar the design value in shear shall not exceed 80 psi (0.552 N/mm<sup>2</sup>) and 75 psi (0.517 N/mm<sup>2</sup>), respectively.

4. The provisions of Items 1, 2 and 3 shall not permit allowable loads which induce horizontal shear stresses,  $f_v$ , when calculated as in Section 2306.3, and Item 5 that exceed two times the shear design values,  $F_v$ , given in Tables 23-I-A-1, 23-I-A-2, 23-I-A-3, 23-I-A-4, 23-I-A-5 and 23-I-A-6. For southern pine, induced horizontal shear stress,  $f_v$ , calculated as in Section 2306.3 and Item 5 shall not exceed [2 x 85 psi (0.586 N/mm<sup>2</sup>)] for lumber S-green, [2 x 90 psi (0.621 N/mm<sup>2</sup>)] for lumber S-dry, or [2 x 95 psi (0.655 N/mm<sup>2</sup>)] for lumber KD-15. For California redwood and yellow poplar, induced horizontal shear stress,  $f_v$ , calculated as in Section 2306.3 and Item 5 shall not exceed [2 x 80 psi (0.552 N/mm<sup>2</sup>)] and [2 x 75 psi (0.517 N/mm<sup>2</sup>)], respectively. Shear design values,  $F_v$ , or equivalent values in the foregoing provisions are subject to modification in accordance with Section 2304.3 and such other sections as may apply (but excepting Note 7 of Tables 23-I-A-1, 23-I-A-2 and 23-I-A-4) before application of the 2.0 factor.

5. **Calculation of design shear.** When calculating the shear force,  $V$ , in bending members:

5.1 All loads within a distance from supports equal to the depth of the bending member may be neglected for beams supported by full bearing on one surface and loads applied to the opposite surface (see Figure 23-VIII-1).

5.2 With a single moving load, or one moving load that is considerably larger than any of the others, the load shall be placed at distances from each support equal to the depth of the bending member, keeping others in their normal relation. With two or more moving loads of about equal weight and in proximity, loads shall be placed in the position that produces the highest shear force,  $V$ , neglecting any load within a distance from a support equal to the depth of the bending member.

TABLE 23-VIII-A—DESIGN VALUES FOR END-GRAIN BEARING PARALLEL TO GRAIN  
ON A RIGID SURFACE,  $F_g$ , IN POUNDS PER SQUARE INCH

SPECIES	DRY SERVICE CONDITIONS <sup>1</sup>			
	WET SERVICE CONDITIONS <sup>1</sup>	Sawn Lumber <sup>2</sup>		Glued-laminated Timber
		More Than 4" (102 mm) Thick	Not More Than 4" (102 mm) Thick <sup>3</sup>	
	× 0.00689 for N/mm <sup>2</sup>			
Ash, commercial white	1,370	1,510	2,060	2,400
Aspen	740	820	1,110	1,300
Balsam fir	1,140	1,250	1,710	1,990
Beech	1,190	1,310	1,780	2,080
Birch, sweet and yellow	1,150	1,260	1,720	2,010
Black cottonwood	620	690	930	1,090
California redwood	1,560	1,720	2,270	2,620
California redwood, open grain	1,150	1,270	1,670	1,940
Coast sitka spruce	950	1,040	1,420	1,660
Coast species	950	1,040	1,420	1,660
Cottonwood, eastern	760	840	1,150	1,340
Douglas fir-larch (dense) <sup>4</sup>	1,570	1,730	2,360	2,750
Douglas fir-larch <sup>4</sup>	1,340	1,480	2,020	2,350
Douglas fir south	1,220	1,340	1,820	2,130
Eastern hemlock—tamarack <sup>4</sup>	1,150	1,270	1,730	2,020
Eastern hemlock	1,140	1,260	1,710	2,000
Eastern softwoods	890	980	1,340	1,560
Eastern spruce	890	980	1,340	1,560
Eastern white pine <sup>4</sup>	900	1,000	1,360	1,580
Eastern woods	740	820	1,110	1,300
Engelmann spruce—alpine fir	810	890	1,220	1,420
Hem-fir <sup>4</sup>	1,110	1,220	1,670	1,940
Hickory and pecan	1,370	1,510	2,050	2,400
Idaho white pine	930	1,020	1,390	1,630
Lodgepole pine	970	1,060	1,450	1,690
Maple, black and sugar	1,140	1,260	1,710	2,000
Mountain hemlock	1,070	1,170	1,600	1,870
Mountain hemlock—hem-fir	1,070	1,170	1,600	1,870

Northern aspen .....	740	810	1,110	1,290
Northern pine .....	1,040	1,150	1,570	1,830
Northern species .....	880	970	1,320	1,540
Northern white cedar .....	740	810	1,110	1,290
Oak, red and white .....	1,060	1,160	1,590	1,850
Ponderosa pine—sugar pine .....	910	1,000	1,370	1,600
Red pine .....	880	970	1,320	1,540
Sitka spruce .....	990	1,090	1,480	1,730
Southern cypress .....	1,330	1,460	1,990	2,320
Southern pine (dense) .....	1,540	1,690	2,310	2,690
Southern pine .....	1,320	1,450	1,970	2,300
Spruce—pine-fir .....	940	1,040	1,410	1,650
Sweetgum and tupelo .....	1,020	1,120	1,530	1,780
Virginia pine—pond pine .....	1,270	1,390	1,800	2,220
Western cedars <sup>4</sup> .....	1,040	1,140	1,820	1,750
Western hemlock .....	1,240	1,360	1,860	2,170
Western white pine .....	930	1,030	1,400	1,630
White woods (western woods) .....	810	890	1,220	1,420
West coast woods (mixed species) .....	810	890	1,220	1,420
Yellow poplar .....	890	980	1,340	1,560

<sup>1</sup>Wet and dry service conditions are defined for sawn lumber and for glued-laminated timber (Section 2304.3).

<sup>2</sup>Applies to sawn lumber members which are at a moisture content of 19 percent or less when full design load is applied, regardless of moisture content at time of manufacture.

<sup>3</sup>When 4-inch (102 mm) or thinner sawn lumber is surfaced at a moisture content of 15 percent or less and is used under dry service conditions, the values listed for glued-laminated timber may be applied.

<sup>4</sup>Values also apply when species name includes the designation "North."

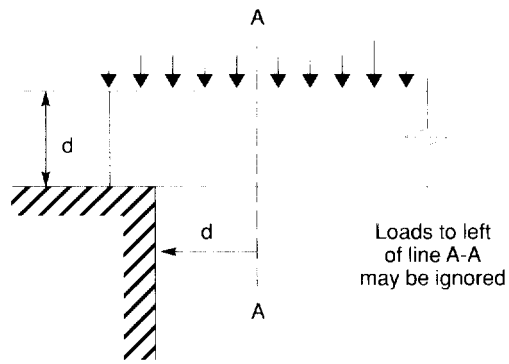

FIGURE 23-VIII-1—LOADS WHICH MAY BE OMITTED

### Chapters 24-34

Chapters 24 through 34 are printed in Volume 1 of the *Uniform Building Code*.

## Appendix

Appendix Chapters 3 through 15 are printed in Volume 1  
of the *Uniform Building Code*

### Appendix Chapter 16 STRUCTURAL FORCES

#### Division I—SNOW LOAD DESIGN

##### SECTION 1634 — GENERAL

**1634.1 Scope.** Buildings, structures and portions thereof shall be designed and constructed to sustain all dead loads plus live loads as provided by Table 16-C or snow loads as defined in this division where such snow loads will result in larger members or connections.

**1634.2 Definitions.** For the purpose of this appendix, certain terms are defined as follows:

**HEATED GREENHOUSE** is a production greenhouse provided with heating facilities capable of maintaining an interior temperature of no less than 50°F. (10°C.) at any point 3 feet (914 mm) above the floor, and provided with roof-ceiling assembly with a thermal resistance (R) less than 2.0.

**PRODUCTION GREENHOUSE** is a greenhouse used exclusively for the growing of flowers or plants on a production basis or for research, with no public access.

##### SECTION 1635 — NOTATIONS

- $a$  = roof slope expressed in degrees.
- $B$  = width of projection measured parallel to ridge, feet (m). Minimum assumed width shall be 1 foot (305 mm).
- $C_e$  = snow exposure factor (see Table A-16-A).
- $C_s$  = slope-reduction factor.
- $C_v$  = valley design coefficient (see Figure A-16-11).
- $D$  = density of snow, pounds per cubic foot (pcf) ( $N/m^3$ ) (refer to Formula 41-2).
- $F_s$  = ice splitter horizontal load, pounds (N).
- $F_v$  = ice splitter snow weight, pounds (N).
- $h_b$  = height of balanced snow load on lower roof or deck, feet (m).
- $h_d$  = maximum height of drift surcharge, feet (m) (refer to Formula 41-1).
- $h_g$  = depth of ground snow (as determined by the building official), feet (m).
- $h_r$  = difference in height between the upper and lower roof or deck, feet (m).
- $I$  = importance factor (see Table A-16-B).
- $L$  = horizontal distance between projection and ridge, feet (m).
- $P_f$  = minimum roof snow load, pounds per square foot (psf) ( $N/m^2$ ).
- $P_g$  = basic ground snow load, psf ( $N/m^2$ ).
- $P_m$  = maximum intensity of the load at the height change, psf ( $N/m^2$ ).
- $S$  = horizontal separation between adjacent structures, feet (m) (see Figure A-16-5).
- $W_b$  = horizontal dimension in feet of upper roof normal to the line of change in roof level, but not less than 50 feet (15.2 m), or greater than 500 feet (152.4 m).
- $W_d$  = width of drift, base of triangular drift load, feet (m).

$X$  = vertical component of roof slope (rise), feet (m).

$Y$  = horizontal component of roof slope (run), feet (m).

### SECTION 1636 — GROUND SNOW LOADS

The ground snow load,  $P_g$ , to be used in the determination of design snow loads for buildings and other structures shall be as shown in Figures A-16-1, A-16-2 and A-16-3. For the hatched areas in Figure A-16-1, the basic ground snow loads shall be determined by the building official. The ground snow load,  $P_g$ , may be adjusted by the building official when a registered engineer or architect submits data substantiating the adjustments.

### SECTION 1637 — ROOF SNOW LOADS

The value of roof (or other member) snow load,  $P_f$ , shall be determined by the following formula:

$$P_f = C_e I P_g \quad (37-1A)$$

where  $C_e$  is given in Table A-16-A and  $I$  is given in Table A-16-B.

**EXCEPTION:** The value of roof snow load,  $P_f$ , for heated greenhouses shall be determined by the following formula:

$$P_f = 0.83 C_e I P_g \quad (37-1B)$$

The roof snow load shall be assumed to act vertically upon the area projected upon a horizontal plane. Portions of curved roofs or inclined walls having a slope exceeding 70 degrees shall be considered free from snow load. The point at which the slope exceeds 70 degrees shall be considered the eave for such roofs. For curved roofs, the roof slope factor,  $C_s$ , shall be determined from the appropriate slope reduction formula by basing the slope on the vertical angle from the eave to the crown.

Where roof snow loads are in excess of 20 psf (958 N/m<sup>2</sup>) and  $a$  is greater than 30 degrees, Formula (37-1A) or (37-1B) may be multiplied by  $C_x$  given by the formula:

$$C_x = 1 - \frac{a - 30}{40} \quad (37-2A)$$

for unobstructed slippery surfaces, and

$$C_x = 1 - \frac{a - 45}{25} \quad (37-2B)$$

for all other surfaces where  $a$  is greater than 45 degrees.

**EXCEPTION:** For heated greenhouses  $C_x$  is given in the formulas:

$$C_x = 1 - \frac{(a - 15)}{55} \quad \text{for unobstructed slippery surfaces} \quad (37-2C)$$

$$C_x = 1 - \frac{(a - 30)}{40} \quad \text{for other surfaces} \quad (37-2D)$$

Where the ground snow load  $P_g$  is greater than 100 psf (4788 N/m<sup>2</sup>) and  $a$  is greater than 20 degrees,

$$C_x = 1 - \left( \frac{P_f - 20}{P_f} \right) \left( \frac{a - 20}{40} \right) \quad (37-2E)$$

For **SI**:

$$C_x = 1 - \left( \frac{P_f - 958}{P_f} \right) \left( \frac{a - 20}{40} \right)$$

The following conditions must be met before using Formulas (37-2A), (37-2B), (37-2C), (37-2D) and (37-2E):

1. The height of all eaves exceeds  $h_g$ , and
2. There are no obstructions adjacent to the structure for a distance  $h_g$  measured from the eave normal to the ridge line.

Where the eave height is less than  $h_g$  but greater than  $h_g/2$ , and condition 2 above is met, the roof snow load reduction represented by the last term in Formulas (37-2A), (37-2B) and (37-2C) shall be divided by 2.

3. If  $P_g$  is 20 psf (958 N/m<sup>2</sup>) or less, design roof snow load must not be less than  $P_g$ . If  $P_g$  exceeds 20 psf (958 N/m<sup>2</sup>), design roof snow load must not be less than 20 psf (958 N/m<sup>2</sup>).

4. Reduced roof loads where  $P_g$  exceeds 70 psf (3352 N/m<sup>2</sup>) shall not be less than those obtained through use of Formula (37-1A) for  $P_g$  equal to 70 psf (3352 N/m<sup>2</sup>).

## SECTION 1638 — UNBALANCED SNOW LOADS, GABLE ROOFS

**1638.1 General.** In addition to the balanced load condition, unbalanced loading shall be considered for gable roofs in accordance with this section.

**1638.2 Single-gable Roofs.** Single-gable roofs with slopes greater than  $1/2:12$  and less than  $3:12$  shall be designed to sustain a uniformly distributed load of  $0.5 P_f$  acting on one slope and  $1.0 P_f$  on the opposite slope. Roofs with slopes greater than  $3:12$  shall be designed to sustain a uniformly distributed load equal to  $1.25 P_f$  applied to one slope only.

### 1638.3 Multiple-gable Roofs.

**1638.3.1 With parallel ridge lines.** For multiple-gable roofs with parallel ridge lines having slopes exceeding  $2:12$ , the roof snow load shall be increased from one half the applicable uniform roof load at the ridge ( $0.5P_f$ ) to three times the uniform load at the valley ( $3.0 P_f$ ).

**1638.3.2 With nonparallel ridge lines.** Structural members at roof valleys for multiple-gable roofs having intersecting ridge lines in areas where  $P_g$  is greater than 70 psf (3352 N/m<sup>2</sup>) and where the slope is  $3:12$  or greater shall be designed for  $P_f$  times  $C_v$  and the distribution of loads is as shown in Figures A-16-12 and A-16-13 where  $C_v$  shall be determined from Figure A-16-11.

## SECTION 1639 — UNBALANCED SNOW LOAD FOR CURVED ROOFS

Portions of curved roofs having a slope exceeding 70 degrees shall be considered free of snow load. The equivalent slope of a curved roof for calculating  $C_s$  is equal to the slope of a line from the point at which the slope exceeds 70 degrees to the crown. If the equivalent slope is less than 10 degrees or greater than 60 degrees, unbalanced snow loads need not be considered.

In all cases the windward side shall be considered free of snow. The unbalanced load varies linearly from  $0.5C_s P_f$  to  $2C_s P_f/C_e$  where the slope is 30 degrees and decreasing to

$$\frac{2C_s P_f}{C_e} \left( 1 - \frac{a - 30}{40} \right) \text{ at the eave.}$$

If the ground or another roof abuts an arched roof structure with a slope exceeding 30 degrees at or within 3 feet (914 mm) of its eave, the snow load shall not be decreased between the 30-degree point and the eave, but shall remain constant at  $2C_s P_f/C_e$ .

## SECTION 1640 — SPECIAL EAVE REQUIREMENTS

Eave overhanging roof structures shall be designed to sustain a uniformly distributed load of  $2.0 P_f$ , or as determined by the building official, to account for ice dams and snow accumulation as shown

in Figure A-16-10. Heat strips or other exposed heat methods may not be used in lieu of this design criterion. For shingle or shake roofs, hot or cold underlayment roofing is required on all roofs from the building edge for a distance of 5 feet (1524 mm) or to the ridge, whichever is less. All building exits under down-slope eaves shall be protected from sliding snow and ice.

### SECTION 1641 — DRIFT LOADS ON LOWER ROOFS, DECKS AND ROOF PROJECTIONS

**1641.1 General.** Multilevel roofs, lower roofs and decks of adjacent structures and roofs adjacent to projections shall be designed in accordance with this section.

**1641.2 Drift Loads for Lower Roofs.** The geometry of the surcharge load produced by snow drifting shall be taken as the triangular load distributions shown in Figures A-16-4, A-16-5, A-16-6, A-16-7 and A-16-8. The height of the drift shall be calculated according to the formula:

$$h_d = 0.43 \sqrt[3]{W_b} \sqrt[4]{P_g + 10} - 1.5 \quad (41-1)$$

For **SI**: Multiply by 305 for mm.

The value of  $h_d$  can be taken from Figure A-16-9 for  $W_b \leq 600$  feet (182.9 m).

**WHERE:**

$$D = 0.13P_g + 14.0 \leq 35 \text{ pcf} \quad (41-2)$$

For **SI**:  $D = 0.43 P_g + 2198 \leq 5495$ .

The width of the drift,  $W_d$ , in feet (m), shall be taken as the smaller of  $4h_d$  or  $4(h_r - h_b)$ . If  $W_d$  exceeds the width of the lower roof, the drift shall be truncated at the far edge of the roof, not reduced to zero at this location. Drift loads need be considered only when:

$$(h_r - h_b)/h_b > 0.2 \quad (41-3)$$

**WHERE:**

$$h_b = P_f / D$$

and where  $P_f$  is evaluated on the basis of the lower roof.

The maximum intensity,  $P_m$ , of the snow load at the high point of the drift in pounds per square foot ( $\text{N}/\text{m}^2$ ) is given by:

$$P_m = D(h_d + h_b) \leq D h_r \quad (41-4)$$

**1641.3 Roof of an Adjacent Lower Structure.** Drifts may occur on lower roofs of structures sited within 20 feet (6.1 m) of a higher structure as depicted in Figure A-16-5. The height of the surcharge on the lower structure shall be taken as  $h_d$  multiplied by  $(20 - S)/20$  [For **SI**:  $(6.1 - S)/6.1$ ] to account for the horizontal separation between structures,  $S$ , in feet (m).

**1641.4 Sliding Snow.** Lower roofs which are located below roofs having a slope greater than 2:12 shall be designed for an increase in drift height of  $0.4h_d$ , except that the total drift surcharge ( $1.4 h_d$ ) shall not exceed the height of the roof above the uniform snow depth ( $h_r - h_b$ ). Sliding snow need not be considered if the lower roof is separated a distance,  $S$ , greater than  $h_r$  or 20 feet (6.1 m) as shown in Figures A-16-5 and A-16-6.

**1641.5 Roof Projections.** Mechanical equipment, penthouses, parapets and other projections above the roof can produce drifting as depicted in Figure A-16-7. Such drift loads shall be calculated on all sides of projections having horizontal dimensions exceeding 15 feet (4.6 m). Drifts created at the perimeter of the roof by projections shall be computed using half the drift height from

Formula (41-1) (i.e.,  $0.5 h_d$ ) with  $W_b$  taken equal to the length of the roof associated with the projections. The value of  $W_b$  shall be taken as the maximum distance from the projection to the edges of the roof, or 50 feet (15.2 m), whichever is less.

**1641.6 Intersecting Drifts.** When one snow drift intersects another at an angle as depicted in Figure A-16-8, the maximum unit pressure of the drift shall be taken as the greater of the two individual drifts, but not the sum of the two. The total load on the area of intersection is increased, however, simply because of the assumed geometry of the intersecting drifts.

### SECTION 1642 — RAIN ON SNOW

In geographic areas where intense rains may add to the roof snow load, the building official may require the use of an additional rain on snow surcharge of 5 psf (239 N/m<sup>2</sup>). This surcharge may be disregarded where roof slopes exceed 1/2:12 or where the basic ground snow load,  $P_g$ , exceeds 50 psf (2394 N/m<sup>2</sup>). See Section 1605.6 for ponding.

### SECTION 1643 — DEFLECTIONS

For roof slopes less than 1/2:12, the deflection of any structural member shall not exceed  $L/180$  evaluated on the basis of roof snow loads plus  $K$  times dead load, where  $K$  is defined in Table 16-E.

### SECTION 1644 — IMPACT LOADS

Whenever  $P_g$  exceeds 70 psf (3352 N/m<sup>2</sup>), structures which could be subjected to impact loads (snow unloading from a higher roof) shall be designed for impact loading.

### SECTION 1645 — VERTICAL OBSTRUCTIONS

Whenever  $P_g$  exceeds 70 psf (3352 N/m<sup>2</sup>), roof projections which could be subjected to sliding ice or snow shall be protected with ice splitters or crickets, or shall be designed for these forces. These conditions apply whenever the roof slope is 3:12 or greater [except those projections within 36 inches (914 mm) of the ridge]. All ice splitters shall be constructed the full width of the projection base (see Figure A-16-14).

Ice splitters shall be designed for a horizontal force  $F_s$  and the resultant moment produced from  $F_s$  being applied at midheight of the splitter given by:

$$F_s = \frac{F_v X}{\sqrt{X^2 + Y^2}} \quad (45-1)$$

**WHERE:**

$$F_v = L(0.5L + B) P_f$$

The projection width,  $B$ , shall not exceed 6 feet (1829 mm) where the roof slope is greater than 2:12 unless approved by the building official. Chimneys and similar projections at or near the eave of a roof shall have footings and roof/wall ties designed to resist the force of the sliding snow. Cross-grain bending of wood ledgers and edge nailing of plywood shall not be considered to resist such forces. Snow melting equipment shall not be considered to reduce the required design loads.

**TABLE A-16-A—SNOW EXPOSURE COEFFICIENT ( $C_e$ )<sup>1,2</sup>**

1. Roofs located in generally open terrain extending one-half mile (804.7 m) or more from the structure.	0.6
2. Structures located in densely forested or sheltered areas.	0.9
3. All other structures.	0.7

<sup>1</sup>The building official may determine this coefficient for specific structures with special local conditions. For Alaska, Arizona and Hawaii, the coefficient shall be determined by the building official.

<sup>2</sup>For roofs at or near grade with slopes less than 3:12 or decks at or near grade,  $C_e$  equals 1.0.

TABLE A-16-B—VALUES FOR OCCUPANCY IMPORTANCE FACTOR *I*

TYPE OF OCCUPANCY	<i>I</i>
	Snow
1. Essential facilities.	1.15
2. Any building where the primary occupancy is for assembly use for more than 300 persons (in one room).	1.15
3. Agricultural buildings, production greenhouses and other miscellaneous structures.	0.9
4. All others.	1.0

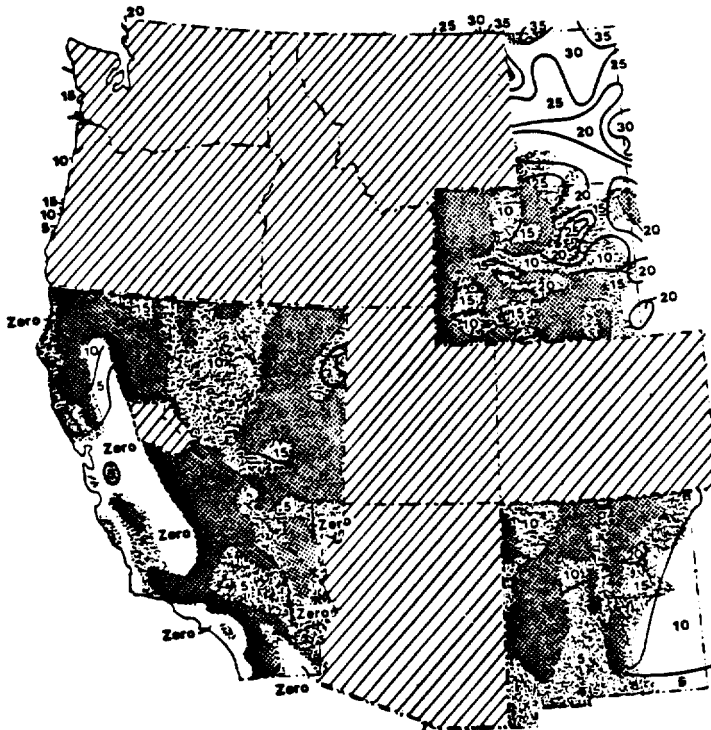









-  In these areas extreme local variations in snow loads preclude mapping at this scale; ground snow load,  $P_g$ , shall be established by the building official.
-  The zoned value is not appropriate for certain geographic settings, such as high country; in these areas, ground snow load,  $P_g$ , shall be established by the building official.
-  In these areas, ground snow load,  $P_g$ , shall be established by the building official.
-  Those areas shown as 0 psf, 5 psf and 10 psf ( $0 \text{ N/m}^2$ ,  $239 \text{ N/m}^2$  and  $479 \text{ N/m}^2$ ) are for information only.

FIGURE A-16-1—GROUND SNOW LOAD,  $P_g$ , FOR 50-YEAR MEAN RECURRENCE INTERVAL FOR THE WESTERN UNITED STATES, Pounds per square foot ( $\times 47.8$  for  $\text{N/m}^2$ )

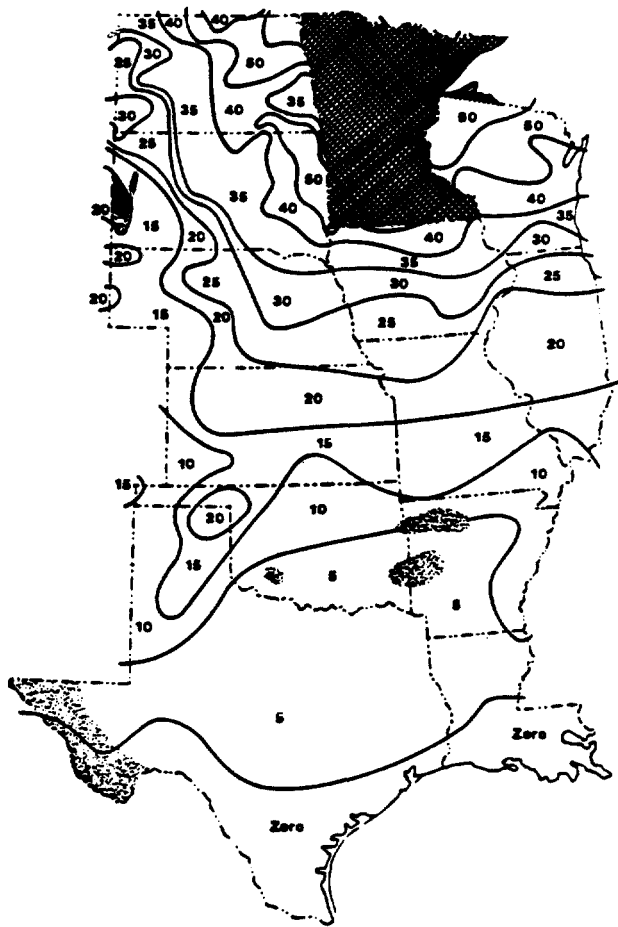

- 

Those areas shown as 0 psf, 5 psf and 10 psf (0 N/m<sup>2</sup>, 239 N/m<sup>2</sup> and 479 N/m<sup>2</sup>) are for information only.
- 

In these areas, extreme local variations in snow loads preclude mapping at this scale; ground snow load,  $P_g$ , shall be established by the building official.
- 

The zoned value is not appropriate for certain geographic settings, such as high country; in these areas, ground snow load,  $P_g$ , shall be established by the building official.

**FIGURE A-16-2—GROUND SNOW LOAD,  $P_g$ , FOR 50-YEAR MEAN RECURRENCE INTERVAL FOR THE CENTRAL UNITED STATES, Pounds per square foot ( $\times 47.8$  for N/m<sup>2</sup>)**

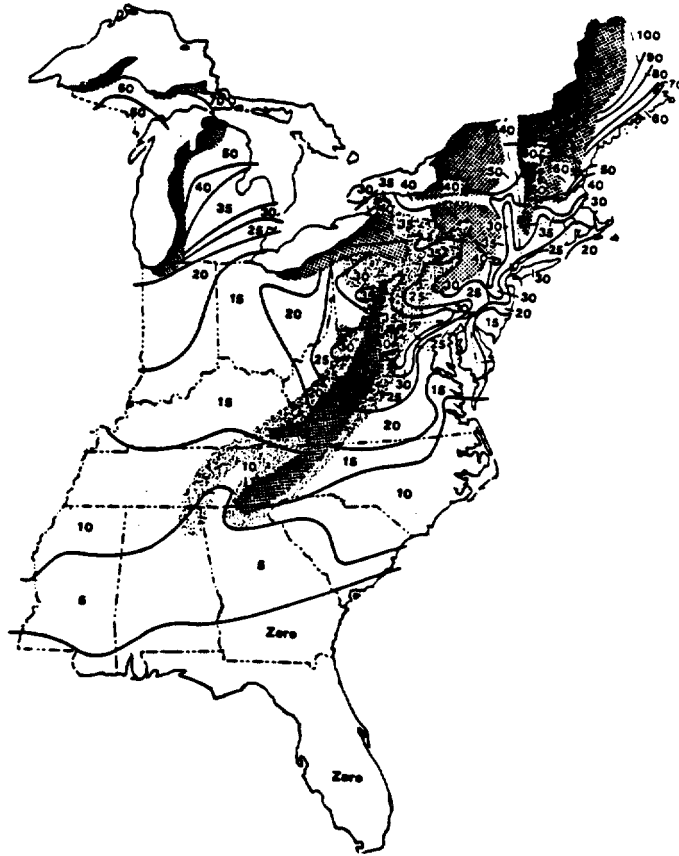

Those areas shown as 0 psf, 5 psf and 10 psf (0 N/m<sup>2</sup>, 239 N/m<sup>2</sup> and 479 N/m<sup>2</sup>) are for information only.



In these areas, extreme local variations in snow loads preclude mapping at this scale; ground snow load,  $P_g$ , shall be established by the building official.



The zoned value is not appropriate for certain geographic settings, such as high country; in these areas, ground snow load,  $P_g$ , shall be established by the building official.

**FIGURE A-16-3—GROUND SNOW LOAD,  $P_g$ , FOR 50-YEAR MEAN RECURRENCE INTERVAL FOR THE EASTERN UNITED STATES, Pounds per square foot ( $\times 47.8$  for N/m<sup>2</sup>)**

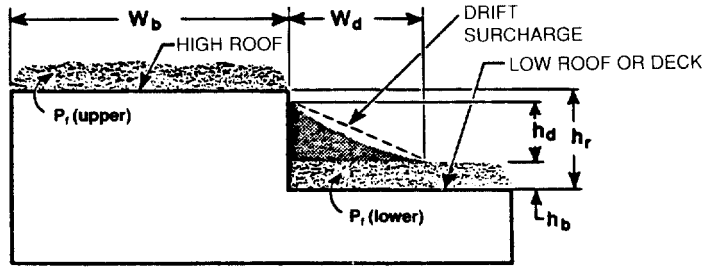
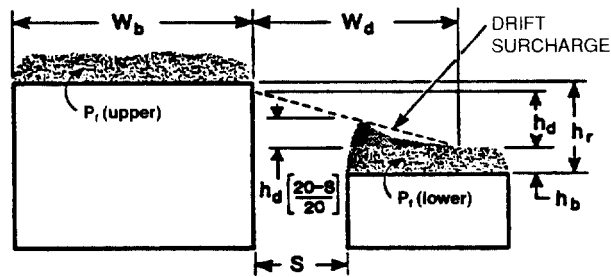

FIGURE A-16-4—DRIFTING SNOW ON LOW ROOFS AND DECKS



For SI:  $h_d \left[ \frac{6.1 - S}{6.1} \right]$

FIGURE A-16-5—DRIFTING SNOW ONTO ADJACENT LOW STRUCTURES

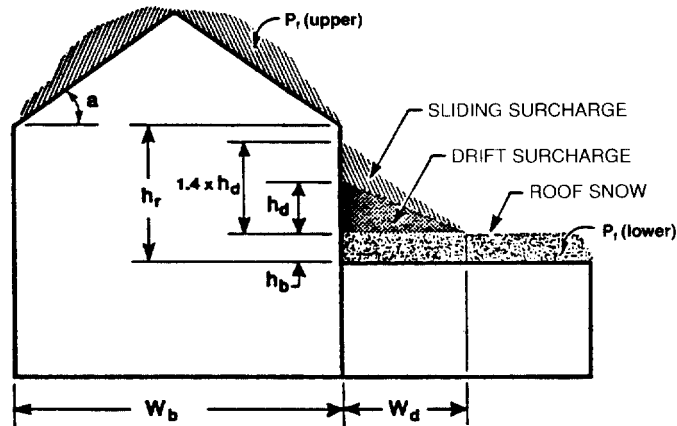

FIGURE A-16-6—ADDITIONAL SURCHARGE DUE TO SLIDING SNOW

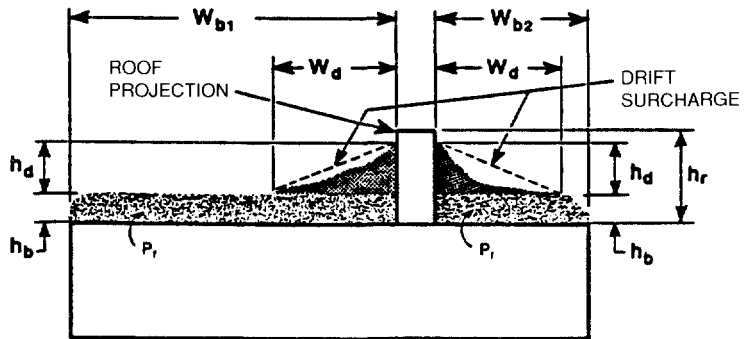

FIGURE A-16-7—SNOW DRIFTING AT ROOF PROJECTIONS

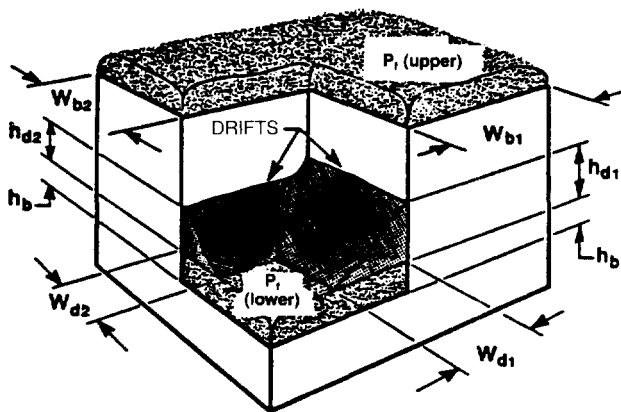

FIGURE A-16-8—INTERSECTING SNOW DRIFTS

NOTE:

$$h_{d1} = 0.43 \sqrt[3]{W_{b1}} \sqrt[4]{P_g + 10} - 1.5$$

$$h_{d2} = 0.43 \sqrt[3]{W_{b2}} \sqrt[4]{P_g + 10} - 1.5$$

For SI: Multiply by 304.8 for mm.

$P_f$  is evaluated on the basis of upper roof.

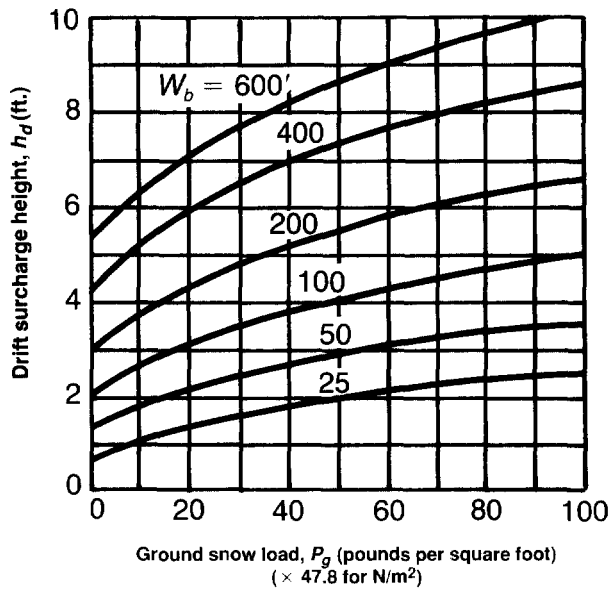

FIGURE A-16-9—DETERMINATION OF  $h_d$   
( $\times 304.8$  for mm)

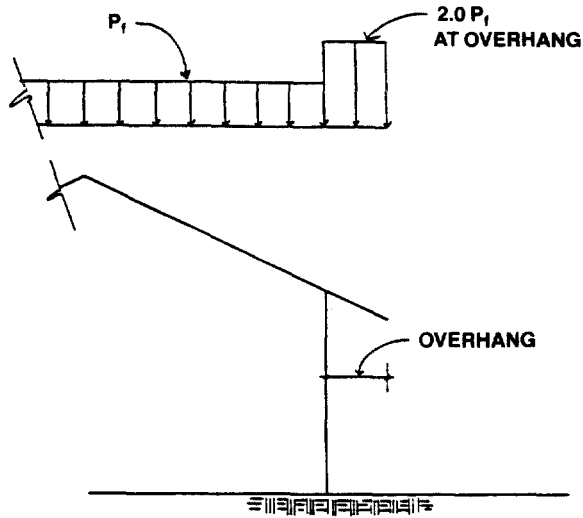

FIGURE A-16-10—OVERHANG LOADS

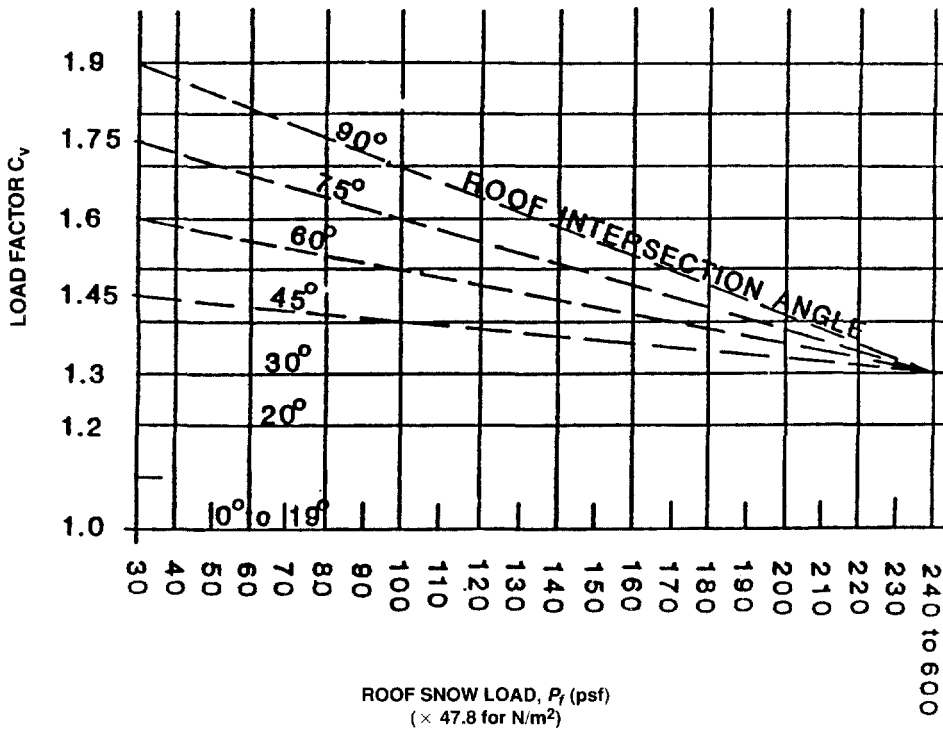
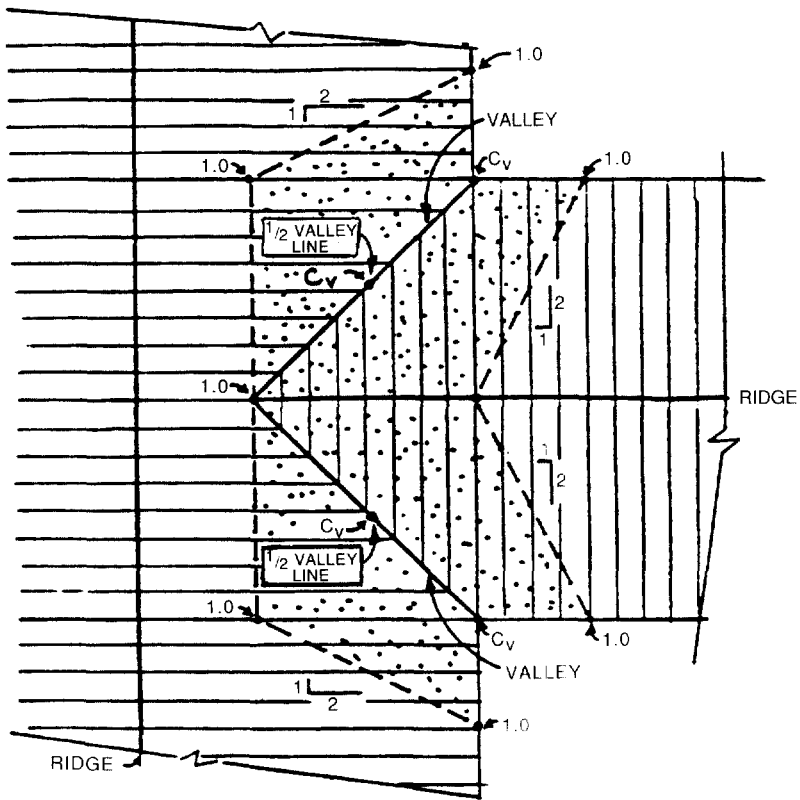

FIGURE A-16-11—VALLEY COEFFICIENT,  $C_v$



DENOTES INCREASED LOAD AREA:

1. Load is constant on lines connecting points noted 1.0.
2. Load is constant on lines connecting points noted  $C_v$ .
3. Load varies linearly between 1.0 and  $C_v$ .

FIGURE A-16-12—VALLEY DESIGN COEFFICIENTS,  $C_v$

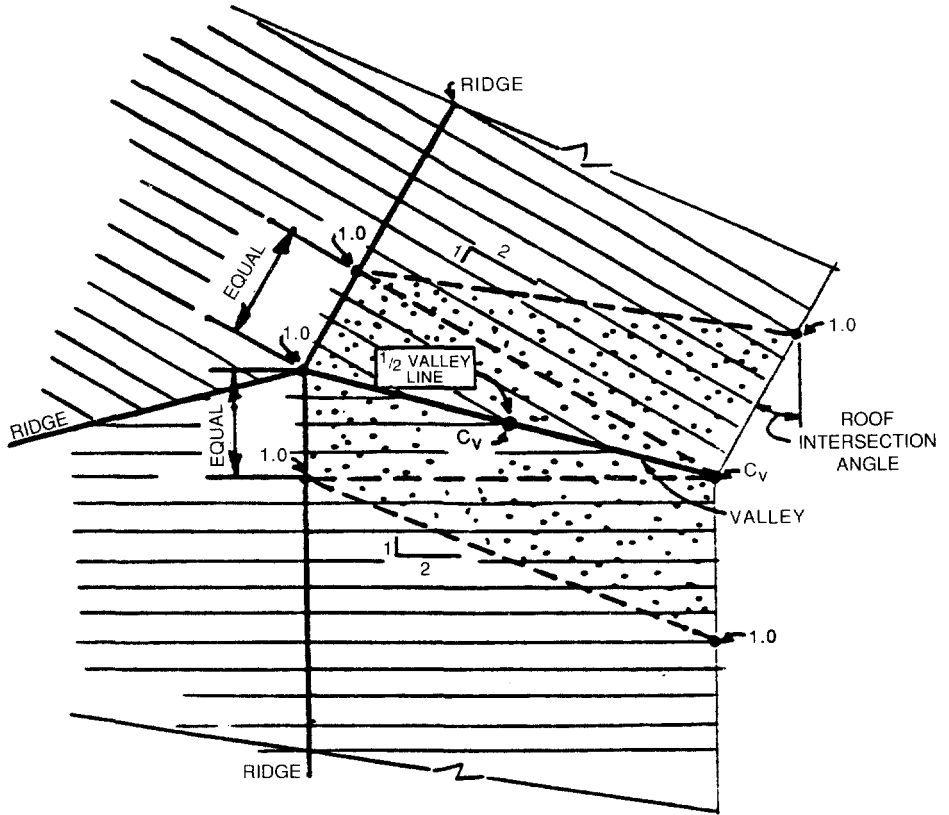

DENOTES INCREASED LOAD AREA:

1. Load is constant on lines connecting points noted 1.0.
2. Load is constant on lines connecting points noted  $C_v$ .
3. Load varies linearly between 1.0 and  $C_v$ .

FIGURE A-16-13—VALLEY DESIGN COEFFICIENTS,  $C_v$

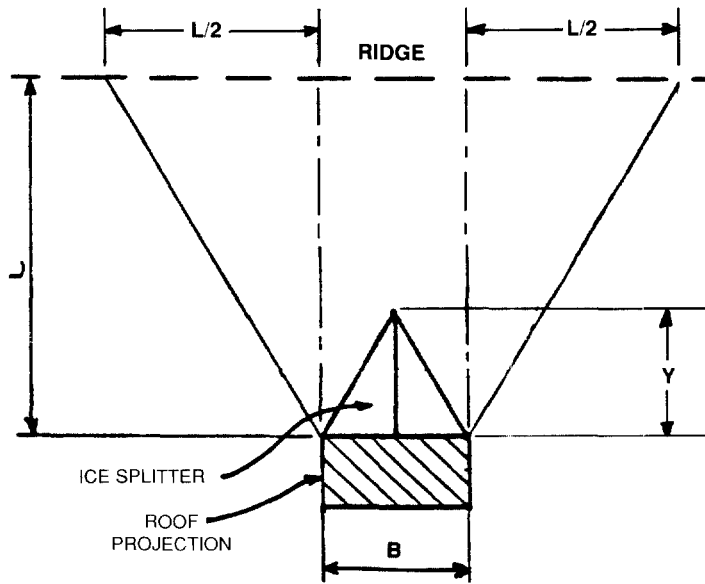

FIGURE A-16-14—ICE SPLITTER—PLAN VIEW

**Division II—EARTHQUAKE RECORDING INSTRUMENTATION**

**SECTION 1646 — GENERAL**

In Seismic Zones 3 and 4 every building over six stories in height with an aggregate floor area of 60,000 square feet (5574 m<sup>2</sup>) or more, and every building over 10 stories in height regardless of floor area, shall be provided with not less than three approved recording accelerographs.

**SECTION 1647 — LOCATION**

The instruments shall be located in the basement, midportion, and near the top of the building. Each instrument shall be located so that access is maintained at all times and is unobstructed by room contents. A sign stating **MAINTAIN CLEAR ACCESS TO THIS INSTRUMENT** shall be posted in a conspicuous location.

**SECTION 1648 — MAINTENANCE**

Maintenance and service of the instruments shall be provided by the owner of the building, subject to the approval of the building official. Data produced by the instruments shall be made available to the building official on request.

**SECTION 1649 — INSTRUMENTATION OF EXISTING BUILDINGS**

All owners of existing structures selected by the jurisdiction authorities shall provide accessible space for the installation of appropriate earthquake-recording instruments. Location of said instruments shall be determined by the jurisdiction authorities. The jurisdiction authorities shall make arrangements to provide, maintain and service the instruments. Data shall be the property of the jurisdiction, but copies of individual records shall be made available to the public on request and the payment of an appropriate fee.

**SEISMIC ZONE TABULATION  
For Areas outside the United States**

<b>Location</b>	<b>Seismic Zone</b>	<b>Location</b>	<b>Seismic Zone</b>
<b>ASIA</b>		<b>PACIFIC OCEAN AREA</b>	
Turkey		Caroline Island	
Ankara	2	Koror, Paulau	2
Karamursel	3	Ponape	0
<b>ATLANTIC OCEAN AREA</b>		Johnston Island	1
Azores	2	Kwajalein	1
Bermuda	1	Mariana Islands	
<b>CARIBBEAN SEA</b>		Guam	3
Bahama Islands	1	Saipan	3
Canal Zone	2	Tinian	3
Leeward Islands	3	Marcus Island	1
Puerto Rico	3	Okinawa	3
Trinidad Island	2	Philippine Islands	3
<b>NORTH AMERICA</b>		Samoa Islands	3
Greenland	1	Wake Island	0
Iceland			
Keflavik	3		

### Division III—EARTHQUAKE REGULATIONS FOR SEISMIC-ISOLATED STRUCTURES

#### SECTION 1650 — GENERAL

Every seismic-isolated structure and every portion thereof shall be designed and constructed in accordance with the requirements of this division and the applicable requirements of Chapter 16, Part III.

The lateral-force-resisting system and the isolation system shall be designed to resist the deformations and stresses produced by the effects of seismic ground motions as provided in this division.

Where wind forces prescribed by Chapter 16, Part II, produce greater deformations or stresses, such loads shall be used for design in lieu of the deformations and stresses resulting from earthquake forces.

#### SECTION 1651 — DEFINITIONS

The definitions of Section 1625 and the following apply to the provisions of this division:

**DESIGN-BASIS EARTHQUAKE** is defined in Section 1629.2.

**DESIGN DISPLACEMENT** is the design-basis earthquake lateral displacement, excluding additional displacement due to actual and accidental torsion, required for design of the isolation system.

**EFFECTIVE DAMPING** is the value of equivalent viscous damping corresponding to energy dissipated during cyclic response of the isolation system.

**EFFECTIVE STIFFNESS** is the value of the lateral force in the isolation system, or an element thereof, divided by the corresponding lateral displacement.

**ISOLATION INTERFACE** is the boundary between the upper portion of the structure, which is isolated, and the lower portion of the structure, which moves rigidly with the ground.

**ISOLATION SYSTEM** is the collection of structural elements which includes all individual isolator units, all structural elements which transfer force between elements of the isolation system, and all connections to other structural elements. The isolation system also includes the wind-restraint system if such a system is used to meet the design requirements of this section.

**ISOLATOR UNIT** is a horizontally flexible and vertically stiff structural element of the isolation system which permits large lateral deformations under design seismic load. An isolator unit may be used either as part of or in addition to the weight-supporting system of the building.

**MAXIMUM CAPABLE EARTHQUAKE** is the maximum level of earthquake ground shaking which may ever be expected at the building site within the known geological framework. In Seismic Zones 3 and 4, this intensity may be taken as the level of earthquake ground motion that has a 10 percent probability of being exceeded in a 100-year time period.

**TOTAL DESIGN DISPLACEMENT** is the design-basis earthquake lateral displacement, including additional displacement due to actual and accidental torsion, required for design of the isolation system, or an element thereof.

**TOTAL MAXIMUM DISPLACEMENT** is the maximum capable earthquake lateral displacement, including additional displacement due to actual and accidental torsion, required for verification of the stability of the isolation system, or elements thereof, design of building separations, and vertical load testing of isolator unit prototypes.

**WIND-RESTRAINT SYSTEM** is the collection of structural elements which provide restraint of the seismic-isolated structure for wind loads. The wind-restraint system may be either an integral part of isolator units or may be a separate device.

**SECTION 1652 — SYMBOLS AND NOTATIONS**

The symbols and notations of Section 1626 and the following provisions apply to the provisions of this division:

- $B$  = numerical coefficient related to the effective damping of the isolation system as set forth in Table A-16-E.
- $b$  = the shortest plan dimension of the structure, in feet (mm), measured perpendicular to  $d$ .
- $D$  = design displacement, in inches (mm), at the center of rigidity of the isolation system in the direction under consideration, as prescribed by Formula (54-1).
- $D'$  = design displacement, in inches (mm), at the center of rigidity of the isolation system in the direction under consideration, as prescribed by Formula (55-1).
- $D_T$  = total design displacement, in inches (mm), of an element of the isolation system including both translational displacement at the center of rigidity,  $D$ , and the component of torsional displacement in the direction under consideration, as specified in Section 1654.3.3.
- $D_{TM}$  = total maximum displacement, in inches (mm), of an element of the isolation system, including both translational displacement at the center of rigidity and the component of torsional displacement in the direction under consideration, as prescribed by Formula (54-4).
- $d$  = the longest plan dimension of the structure, in feet (mm).
- $e$  = the actual eccentricity, in feet (mm), measured in plan between the center of mass of the structure above the isolation interface and the center of rigidity of the isolation system, plus accidental eccentricity, in feet (mm), taken as 5 percent of the maximum building dimension perpendicular to the direction of force under consideration.
- $F^-$  = maximum negative force in an isolator unit during a single cycle of prototype testing at a displacement amplitude of  $\Delta^-$ .
- $F_{max}^-$  = maximum negative force in an isolator unit for all cycles of prototype testing at a common displacement amplitude of  $\Delta^-$ .
- $F_{min}^-$  = minimum negative force in an isolator unit for all cycles of prototype testing at a common displacement amplitude of  $\Delta^-$ .
- $F^+$  = maximum positive force in an isolator unit during a single cycle of prototype testing at a displacement amplitude of  $\Delta^+$ .
- $F_{max}^+$  = maximum positive force in an isolator unit for all cycles of prototype testing at a common displacement amplitude of  $\Delta^+$ .
- $F_{min}^+$  = minimum positive force in an isolator unit for all cycles of prototype testing at a common displacement amplitude of  $\Delta^+$ .
- $k_{eff}$  = effective stiffness of an isolator unit, as prescribed by Formula (61-1).
- $k_{max}$  = maximum effective stiffness of the isolation system at the design displacement in the horizontal direction under consideration.
- $k_{min}$  = minimum effective stiffness of the isolation system at the design displacement in the horizontal direction under consideration.
- $M_M$  = numerical coefficient related to maximum capable earthquake response as set forth in Table A-16-G.
- $N$  = numerical coefficient related to both the proximity of the building or structure to an active fault, and fault magnitude, as set forth in Table A-16-D.
- $R_{wf}$  = numerical coefficient related to the type of lateral force-resisting system above the isolation system as set forth in Table A-16-F for seismic-isolated structures.
- $S_I$  = numerical coefficient for site-soil profile as set forth in Table A-16-C for seismic-isolated structures.

- $T_I$  = period of seismic-isolated structure, in seconds, in the direction under consideration, as prescribed by Formula (54-2).
- $V_b$  = the total lateral seismic design force or shear on elements of the isolation system or elements below the isolation system as prescribed by Formula (54-5).
- $V_s$  = the total lateral seismic design force or shear on elements above the isolation system as prescribed by Formula (54-6).
- $W$  = the total seismic dead load defined in Section 1628.1. For design of the isolation system,  $W$  is the total seismic dead load weight of the structure above the isolation interface.
- $y$  = the distance, in feet (mm), between the center of rigidity of the isolation system rigidity and the element of interest, measured perpendicular to the direction of seismic loading under consideration.
- $\beta$  = effective damping of the isolation system, as prescribed by Formula (61-2).
- $\Delta+$  = maximum positive displacement of an isolator unit during each cycle of prototype testing.
- $\Delta-$  = maximum negative displacement of an isolator unit during each cycle of prototype testing.

## SECTION 1653 — CRITERIA SELECTION

**1653.1 Basis for Design.** The procedures and limitations for the design of seismic-isolated structures shall be determined considering zoning, site characteristics, vertical acceleration, cracked section properties of concrete and masonry members, occupancy, configuration, structural system and height in accordance with Section 1627, except as noted below.

**1653.2 Stability of the Isolation System.** The stability of the vertical load-carrying elements of the isolation system shall be verified by analysis and test, as required, for lateral seismic displacement equal to the total maximum displacement.

**1653.3 Occupancy Categories.** The importance factor,  $I$ , for a seismic-isolated building shall be taken as 1.0 regardless of occupancy category.

**1653.4 Configuration Requirements.** Each structure shall be designated as being regular or irregular on the basis of the structural configuration above the isolation system.

### 1653.5 Selection of Lateral Response Procedure.

**1653.5.1 General.** Any seismic-isolated structure may be, and certain seismic-isolated structures defined below shall be, designed using the dynamic lateral response procedure of Section 1655.

**1653.5.2 Static analysis.** The static lateral response procedure of Section 1654 may be used for design of a seismic-isolated structure, provided:

1. The structure is located at least 15 kilometer (km) from all active faults.
2. The structure is located on a soil profile with a site factor of  $S_1$  or  $S_2$ .
3. The structure is located in Seismic Zone 3 or 4.
4. The structure above the isolation interface is equal to or less than four stories, or 65 feet (19.8 m), in height.
5. The isolated period of the structure,  $T_I$ , is equal to or less than 3.0 seconds.
6. The isolated period of the structure,  $T_I$ , is greater than 3 times the elastic, fixed-base period of the structure above the isolation system, as determined by Formula (28-5) of Section 1628.
7. The structure above the isolation system is of regular configuration.

8. The isolation system is defined by all of the following attributes:
  - 8.1 The effective stiffness of the isolation system at the design displacement is greater than one third of the effective stiffness at 20 percent of the design displacement.
  - 8.2 The isolation system is capable of producing a restoring force, as specified in Section 1657.2.4.
  - 8.3 The isolation system has force-deflection properties which are independent of the rate of loading.
  - 8.4 The isolation system has force-deflection properties which are independent of vertical load and bilateral load.
  - 8.5 The isolation system does not limit maximum capable earthquake displacement to less than  $M_M$  times the total design displacement.

**1653.5.3 Dynamic analysis.** The dynamic lateral response procedure of Section 1655 shall be used for design of seismic-isolated structures as specified below:

1. **Response spectrum analysis.** Response spectrum analysis may be used for design of a seismic-isolated structure, provided:
  - 1.1 The structure is located on a soil profile with a site factor of  $S_1$ ,  $S_2$  or  $S_3$ .
  - 1.2 The isolation system is defined by all of the attributes specified in Section 1653.5.2, Item 8.
2. **Time-history analysis.** Time-history analysis may be used for design of any seismic-isolated structure and shall be used for design of all seismic-isolated structures not meeting the criteria of Section 1653.5.3, Item 1.
3. **Site-specific design spectra.** Site-specific ground motion spectra of the design-basis earthquake and the maximum capable earthquake, developed in accordance with Section 1629.2, shall be used for design and analysis of all seismic-isolated structures as specified below:
  1. The structure is located on a soil profile with a site factor of  $S_3$  or  $S_4$ .
  2. The structure is located within 15 km of an active fault.
  3. The structure is located in Seismic Zone I, 2A or 2B.
  4. The isolated period of the structure,  $T_I$ , is greater than 3.0 seconds.

## SECTION 1654 — STATIC LATERAL RESPONSE PROCEDURE

**1654.1 General.** Except as provided in Section 1655, every seismic-isolated structure, or portion thereof, shall be designed and constructed to resist minimum earthquake displacements and forces as specified by this section and the applicable requirements of Section 1628.

**1654.2 Deformation Characteristics of the Isolation System.** Minimum lateral earthquake design displacements and forces on seismic-isolated structures shall be based on the deformation characteristics of the isolation system.

The deformation characteristics of the isolation system shall explicitly include the effects of the wind-restraint system if such a system is used to meet the design requirements of this document.

The deformation characteristics of the isolation system shall be based on properly substantiated tests performed in accordance with Section 1661.

### 1654.3 Minimum Lateral Displacements.

**1654.3.1 Design displacement.** The isolation system shall be designed and constructed to withstand minimum lateral earthquake displacements which act in the direction of each of the main horizontal axes of the structure in accordance with the formula:

$$D = \frac{10ZNS_1T_1}{B} \quad (54-1)$$

For **SI**:

$$D = \frac{254ZNS_1T_1}{B}$$

**1654.3.2 Isolated-structure period.** The isolated-structure period,  $T_I$ , shall be determined using the deformational characteristics of the isolation system in accordance with the formula:

$$T_I = 2\pi \sqrt{\frac{W}{k_{\min}g}} \quad (54-2)$$

**1654.3.3 Total design displacement.** The total design displacement,  $D_T$ , of elements of the isolation system shall include additional displacement due to actual and accidental torsion calculated considering the spatial distribution of the lateral stiffness of the isolation system and the most disadvantageous location of mass eccentricity.

The total design displacement,  $D_T$ , of elements of an isolation system with uniform spatial distribution of lateral stiffness shall not be taken as less than that prescribed by the formula:

$$D_T = D \left[ 1 + y \frac{12e}{b^2 + d^2} \right] \quad (54-3)$$

The total design displacement,  $D_T$ , may be taken as less than the value prescribed by Formula (54-3), but not less than 1.1 times  $D$ , provided the isolation system is shown by calculation to be configured to resist torsion accordingly.

**1654.3.4 Total maximum displacement.** The total maximum displacement,  $D_{TM}$ , required for verification of isolation system stability in the most critical direction of horizontal response shall be calculated in accordance with the formula:

$$D_{TM} = M_M D_T \quad (54-4)$$

#### 1654.4 Minimum Lateral Forces.

**1654.4.1 Isolation system and structural elements at or below the isolation system.** The isolation system, the foundation, and all structural elements below the isolation system shall be designed and constructed to withstand a minimum lateral seismic force,  $V_b$ , using all of the appropriate provisions for a nonisolated structure where:

$$V_b = \frac{k_{\max}D}{1.5} \quad (54-5)$$

**1654.4.2 Structural elements above the isolation system.** The structure above the isolation system shall be designed and constructed to withstand a minimum shear force,  $V_s$ , using all of the appropriate provisions for a nonisolated structure where:

$$V_s = \frac{k_{\max}D}{R_{wI}} \quad (54-6)$$

The  $R_{wI}$  factor shall be based on the type of lateral-force-resisting system used for the structure above the isolation system.

**1654.4.3 Limits on  $V_s$ .** The value of  $V_s$  shall not be taken as less than the following:

1. The lateral seismic force required by Chapter 16, Division III, for a fixed-base structure of the same weight,  $W$ , and a period equal to the isolated period,  $T_I$ .
2. The base shear corresponding to the design wind load.

3. The lateral seismic force required to fully activate the isolation system (e.g., the yield level of a softening system, the ultimate capacity of a sacrificial wind-restraint system or the static friction level of a sliding system).

**1654.5 Vertical Distribution of Force.** The total force shall be distributed over the height of the structure above the isolation interface in accordance with the formula:

$$F_x = \frac{V_s w_x h_x}{\sum_{i=1}^n w_i h_i} \quad (54-7)$$

At each level designated as  $x$ , the force  $F_x$  shall be applied over the area of the building in accordance with the mass distribution at the level. Stresses in each structural element shall be calculated as the effect of force,  $F_x$ , applied at the appropriate levels above the base.

**1654.6 Drift Limits.** The maximum interstory drift ratio of the structure above the isolation system shall not exceed  $0.010/R_{wI}$ .

## SECTION 1655 — DYNAMIC LATERAL-RESPONSE PROCEDURE

**1655.1 General.** As required by Section 1653, every seismic-isolated structure, or portion thereof, shall be designed and constructed to resist earthquake displacements and forces as specified in this section and the applicable requirements of Section 1629.

**1655.2 Isolation System and Structural Elements below the Isolation System.** The total design displacement of the isolation system shall not be taken as less than 90 percent of  $D_T$  as specified by Section 1654.3.3.

The total maximum displacement of the isolation system shall not be taken as less than 80 percent of  $D_{TM}$  as prescribed by Formula (54-4).

The design lateral shear force on the isolation system and structural elements below the isolation system shall not be taken as less than 90 percent of  $V_b$  as prescribed by Formula (54-5).

The limits of the first and third paragraphs of Section 1655.2 shall be evaluated using values of  $D_T$  and  $D_{TM}$  determined in accordance with Section 1654.3, except that  $D'$  may be used in lieu of  $D$ , where  $D'$  is prescribed by the formula:

$$D' = \frac{D}{\sqrt{1 + (T/T_1)^2}} \quad (55-1)$$

and  $T$  is the elastic, fixed-base period of the structure above the isolation system, as determined only by Formula (34-5) of Section 1628.

**1655.3 Structural Elements above the Isolation System.** The design lateral shear force on the structure above the isolation system, if regular in configuration, shall not be taken as less than 80 percent of  $k_{max}D/R_{wI}$ , or less than the limits specified by Section 1654.4.3.

**EXCEPTION:** The design lateral shear force on the structure above the isolation system, if regular in configuration, may be taken as less than 80 percent of  $k_{max}D/R_{wI}$ , but not less than 60 percent of  $k_{max}D/R_{wI}$ , provided time-history analysis is used for design of the structure.

The design lateral shear force on the structure above the isolation system, if irregular in configuration, shall not be taken as less than  $k_{max}D/R_{wI}$ , or less than the limits specified by Section 1654.4.3.

**EXCEPTION:** The design lateral shear force on the structure above the isolation system, if irregular in configuration, may be taken as less than  $k_{max}D/R_{wI}$ , but not less than 80 percent of  $k_{max}D/R_{wI}$ , provided time-history analysis is used for design of the structure.

### 1655.4 Ground Motion.

**1655.4.1 Design spectra.** Properly substantiated, site-specific spectra are required for design of all structures with an isolated period,  $T_I$ , greater than 3.0 seconds, or located on a soil type profile of  $S_3$  or  $S_4$ , or located within 15 km of an active fault or located in Seismic Zone 1, 2A or 2B. Structures that do not require site-specific spectra and for which site-specific spectra have not been calculated shall be designed using spectra based on Figure 16-3 of Chapter 16, Part III.

A design spectrum shall be constructed for the design-basis earthquake. This design spectrum shall not be taken as less than the normalized response spectrum given in Figure 16-3 of Chapter 16, Part III, for the appropriate soil type, scaled by the product  $ZN$ .

**EXCEPTION:** If a site-specific spectrum is calculated for the design-basis earthquake, then the design spectrum may be taken as less than 100 percent, but not less than 80 percent of the normalized response spectrum given in Figure 16-3 of Chapter 16, Part III, the appropriate soil type, scaled by the product  $ZN$ .

A design spectrum shall be constructed for the maximum capable earthquake. This design spectrum shall not be taken as less than the normalized spectrum given in Figure 16-3 of Chapter 16, Part III, for the appropriate soil type, scaled by the product  $M_M ZN$ . This design spectrum shall be used to determine the total maximum displacement and overturning forces for design and testing of the isolation system.

**EXCEPTION:** If a site-specific spectrum is calculated for the maximum capable earthquake, then the design spectrum may be taken as less than 100 percent, but not less than 80 percent of the normalized response spectrum given in Figure 16-3 of Chapter 16, Part III, for the appropriate soil type, scaled by the product  $M_M ZN$ .

**1655.4.2 Time histories.** Pairs of horizontal ground-motion time-history components shall be selected from not less than three recorded events. For each pair of horizontal ground-motion components, the square root sum of the squares (SRSS) of the 5 percent-damped spectrum of the scaled horizontal components shall be constructed. The motions shall be scaled such that the average value of the SRSS spectra does not fall below 1.3 times the 5 percent-damped spectrum of the design-basis earthquake (or maximum capable earthquake) by more than 10 percent in the period range of  $T_I$  as determined by Formula (54-2), for periods from  $T_I$  minus 1.0 seconds to  $T_I$  plus 2.0 seconds.

The duration of the time histories shall be consistent with the magnitude and source characteristics of the design-basis earthquake (or maximum capable earthquake).

Time histories developed for sites within 15 km of a major active fault shall incorporate near-fault phenomena.

### 1655.5 Mathematical Model.

**1655.5.1 General.** The mathematical models of the isolated structure, including the isolation system, the lateral-force-resisting system and other structural elements, shall conform to Section 1629.5 and to the requirements of Sections 1655.5.2 and 1655.5.3 below.

**1655.5.2 Isolation system.** The isolation system shall be modeled using deformational characteristics developed and verified by test in accordance with the requirements of Section 1654.2.

The isolation system shall be modeled with sufficient detail to:

1. Account for the spatial distribution of isolator units,
2. Calculate translation, in both horizontal directions, and torsion of the structure above the isolation interface, considering the most disadvantageous location of mass eccentricity,
3. Assess overturning/uplift forces on individual isolator units, and
4. Account for the effects of vertical load, bilateral load and/or the rate of loading if the force deflection properties of the isolation system are dependent on one or more of these attributes.

### 1655.5.3 Isolated structure.

**1655.5.3.1 Displacement.** The maximum displacement of each floor and the total design displacement and total maximum displacement across the isolation system shall be calculated using a

model of the isolated structure which incorporates the force-deflection characteristics of nonlinear elements of the isolation system and the lateral-force-resisting system.

Isolation systems with nonlinear elements include, but are not limited to, systems which do not meet the criteria of Section 1653.5.2, Item 8.

Lateral-force-resisting systems with nonlinear elements include, but are not limited to, irregular structural systems designed for a lateral force less than  $k_{max}D/R_{wl}$  and regular structural systems designed for a lateral force less than 80 percent of  $k_{max}D/R_{wl}$ .

**1655.5.3.2 Forces and displacements in key elements.** Design forces and displacements in key elements of the lateral-force-resisting system may be calculated using a linear elastic model of the isolated structure, provided:

1. Pseudo-elastic properties assumed for nonlinear isolation system components are based on the maximum effective stiffness of the isolation system.
2. All key elements of the lateral-force-resisting system are linear.

#### **1655.6 Description of Analysis Procedures.**

**1655.6.1 General.** A response spectrum analysis or a time-history analysis, or both, shall be performed in accordance with Sections 1629.4 and 1629.5 and the requirements of this section.

**1655.6.2 Input earthquake.** The design-basis earthquake shall be used to calculate the total design displacement of the isolation system and the lateral forces and displacements of the isolated structure. The maximum capable earthquake shall be used to calculate the total maximum displacement of the isolation system.

**1655.6.3 Response spectrum analysis.** Response spectrum analysis shall be performed using a damping value equal to the effective damping of the isolation system or 30 percent of critical, whichever is less.

Response spectrum analysis used to determine the total design displacement and the total maximum displacement shall include simultaneous excitation of the model by 100 percent of the most critical direction of ground motion and 30 percent of the ground motion on the orthogonal axis. The maximum displacement of the isolation system shall be calculated as the vectorial sum of the two orthogonal displacements.

**1655.6.4 Time-history analysis.** Time-history analysis shall be performed with at least three appropriate pairs of horizontal time-history components, as defined in Section 1655.4.2.

Each pair of time histories shall be applied simultaneously to the model, considering the most disadvantageous location of mass eccentricity. The maximum displacement of the isolation system shall be calculated from the vectorial sum of the two orthogonal displacements at each time step.

The parameter of interest shall be calculated for each time-history analysis. If three time-history analyses are performed, then the maximum response of the parameter of interest shall be used for design. If seven or more time-history analyses are performed, then the average value of the response parameter of interest may be used for design.

#### **1655.7 Design Lateral Force.**

**1655.7.1 Isolation system and structural elements at or below the isolation system.** The isolation system, foundation and all structural elements below the isolation system shall be designed using all of the appropriate provisions for a nonisolated structure and the forces obtained from the dynamic analysis reduced by a factor of 1.5.

**1655.7.2 Structural elements above the isolation system.** Structural elements above the isolation system shall be designed using the appropriate provisions for a nonisolated structure and the forces obtained from the dynamic analysis reduced by a factor of  $R_{wl}$ . The  $R_{wl}$  factor shall be based on the type of lateral-force-resisting system used for the structure above the isolation system.

**1655.7.3 Scaling of results.** When the factored lateral shear force on structural elements, determined using either response spectrum or time-history analysis, is less than minimum level prescribed by Sections 1655.1 and 1655.2, then all response parameters, including member forces and moments shall be adjusted upward proportionally.

**1655.8 Drift Limits.** Maximum interstory drift corresponding to the design lateral force, including displacement due to vertical deformation of the isolation system, shall not exceed the following limits:

1. The maximum interstory drift ratio of the structure above the isolation system, calculated by response spectrum analysis, shall not exceed  $0.015/R_{wl}$ .
2. The maximum interstory drift ratio of the structure above the isolation system, calculated by time-history analysis considering the force-deflection characteristics of nonlinear elements of the lateral-force-resisting system, shall not exceed  $0.020/R_{wl}$ .

The secondary effects of the maximum capable earthquake lateral displacement,  $\Delta$ , of the structure above the isolation system combined with gravity forces shall be investigated if the interstory drift ratio exceeds  $0.010/R_{wl}$ .

## **SECTION 1656 — LATERAL LOAD ON ELEMENTS OF STRUCTURES AND NONSTRUCTURAL COMPONENTS SUPPORTED BY STRUCTURES**

**1656.1 General.** Parts or portions of an isolated structure, permanent nonstructural components and the attachments to them, and the attachments for permanent equipment supported by a structure shall be designed to resist seismic forces and displacements as prescribed by this section and the applicable requirements of Section 1630.

### **1656.2 Forces and Displacements.**

**1656.2.1 Components at or above the isolation interface.** Elements of seismic-isolated structures and nonstructural components, or portions thereof, which are at or above the isolation interface, shall be designed to resist a total lateral seismic force equal to the maximum dynamic response of the element or component under consideration divided by a factor of 1.5.

**EXCEPTION:** Elements of seismic-isolated structures and nonstructural components, or portions thereof, may be designed to resist total lateral seismic force as prescribed by Formula (36-1) of Section 1630.

**1656.2.2 Components which cross the isolation interface.** Elements of seismic-isolated structures and nonstructural components, or portions thereof, which cross the isolation interface shall be designed to withstand the total maximum displacement.

**1656.2.3 Components below the isolation interface.** Elements of seismic-isolated structures and nonstructural components, or portions thereof, which are below the isolation interface shall be designed and constructed in accordance with the requirements of Section 1630.

## **SECTION 1657 — DETAILED SYSTEMS REQUIREMENTS**

**1657.1 General.** The isolation system and the structural system shall comply with the requirements of Section 1631 and the material requirements of Chapters 19 through 23. In addition, the isolation system shall comply with the detailed system requirements of this section and the structural system shall comply with the detailed system requirements of this section and the applicable portions of Section 1631.

### **1657.2 Isolation System.**

**1657.2.1 Environmental conditions.** In addition to the requirements for vertical and lateral loads induced by wind and earthquake, the isolation system shall be designed with consideration given to other environmental conditions including aging effects, creep, fatigue, operating temperature and exposure to moisture or damaging substances.

**1657.2.2 Wind forces.** Isolated structures shall resist design wind loads at all levels above the isolation interface in accordance with the general wind design provisions. At the isolation interface, a wind restraint system shall be provided to limit lateral displacement in the isolation system to a value equal to that required between floors of the structure above the isolation interface.

**1657.2.3 Fire resistance.** Fire resistance for the isolation system shall meet that required for the building columns, walls or other structural elements.

**1657.2.4 Lateral restoring force.** The isolation system shall be configured to produce a restoring force such that the lateral force at the total design displacement is at least  $0.025W$  greater than the lateral force at 50 percent of the total design displacement.

**EXCEPTION:** The isolation system need not be configured to produce a restoring force, as required above, provided the isolation system is capable of remaining stable under full vertical load and accommodating a total maximum displacement equal to the greater of either 3.0 times the total design displacement or  $36M_MZNS_I$  inches (For SI:  $914.4 M_MZNS_I$  mm).

**1657.2.5 Displacement restraint.** The isolation system may be configured to include a displacement restraint that limits lateral displacement due to the maximum capable earthquake to less than  $M_M$  times the total design displacement, provided that the seismic-isolated structure is designed in accordance with the following criteria when more stringent than the requirements of Section 1627:

1. Maximum capable earthquake response is calculated in accordance with the dynamic analysis requirements of Section 1629, explicitly considering the nonlinear characteristics of the isolation system and the structure above the isolation system.
2. The ultimate capacity of the isolation system and structural elements below the isolation system shall exceed the strength and displacement demands of the maximum capable earthquake.
3. The structure above the isolation system is checked for stability and ductility demand of the maximum capable earthquake.
4. The displacement restraint does not become effective at a displacement less than 0.75 times the total design displacement unless it is demonstrated by analysis that earlier engagement does not result in unsatisfactory performance.

**1657.2.6 Vertical load stability.** Each element of the isolation system shall be designed to be stable under the full design vertical load ( $1.2DL + 1.0LL + |E|$ ) at a horizontal displacement equal to the total maximum displacement. Vertical load due to earthquake,  $|E|$ , shall be based on peak response due to the maximum capable earthquake.

**1657.2.7 Overturning.** The factor of safety against global structural overturning at the isolation interface shall not be less than 1.0 for required load combinations. All gravity and seismic loading conditions shall be investigated. Seismic forces for overturning calculations shall be based on the maximum capable earthquake and  $W$  shall be used for the vertical restoring force.

Local uplift of individual elements is permitted provided the resulting deflections do not cause overstress or instability of the isolator units or other building elements.

**1657.2.8 Inspection and replacement.** Access for inspection and replacement of all components of the isolation system shall be provided.

**1657.2.9 Quality control.** A quality control testing program for isolator units shall be established by the engineer responsible for the structural design.

### **1657.3 Structural System.**

**1657.3.1 Horizontal distribution of force.** A horizontal diaphragm or other structural elements shall provide continuity above the isolation interface and shall have adequate strength and ductility to transmit forces (due to nonuniform ground motion) from one part of the building to another.

**1657.3.2 Building separations.** Minimum separations between the isolated building and surrounding retaining walls or other fixed obstructions shall not be less than the total maximum displacement.

**SECTION 1658 — NONBUILDING STRUCTURES**

Nonbuilding structures shall be designed in accordance with the requirements of Section 1632 using design displacements and forces calculated in accordance with Section 1654 or 1655.

**SECTION 1659 — FOUNDATIONS**

Foundations shall be designed and constructed in accordance with the requirements of Chapter 18 using design forces calculated in accordance with Section 1654 or 1655.

**SECTION 1660 — DESIGN AND CONSTRUCTION REVIEW**

**1660.1 General.** A design review of the isolation system and related test programs shall be performed by an independent engineering team including persons licensed in the appropriate disciplines, experienced in seismic analysis methods and the theory and application of seismic isolation.

**1660.2 Isolation System.** Isolation system design review shall include, but not be limited to, the following:

1. Review of site-specific seismic criteria, including the development of site-specific spectra and ground motion time histories, and all other design criteria developed specifically for the project.
2. Review of the preliminary design, including the determination of the total design displacement of the isolation system design displacement and lateral force design level.
3. Overview and observation of prototype testing (Section 1661).
4. Review of the final design of the entire structural system and all supporting analyses.
5. Review of the isolation system quality control testing program (Section 1657.2.9).

**SECTION 1661 — REQUIRED TESTS OF ISOLATION SYSTEM**

**1661.1 General.** The deformation characteristics and damping values of the isolation system used in the design and analysis of seismic-isolated structures shall be based on the following tests of a selected sample of the components prior to construction.

The isolation system components to be tested shall include the wind restraint system if such systems are used in the design.

The tests specified in this section are for establishing and validating the design properties of the isolation system, and shall not be considered as satisfying the manufacturing quality control tests of Section 1657.2.9.

**1661.2 Prototype Tests.**

**1661.2.1 General.** Prototype tests shall be performed separately on two full-size specimens of each type and size of isolator unit of the isolation system. The test specimens shall include the wind restraint system, as well as individual isolator units, if such systems are used in the design. Specimens tested shall not be used for construction.

**1661.2.2 Record.** For each cycle of tests the force-deflection and hysteretic behavior of the test specimen shall be recorded.

**1661.2.3 Sequence and cycles.** The following sequence of tests shall be performed for the prescribed number of cycles at a vertical load equal to the average  $DL + 0.5LL$  on all isolator units of a common type and size:

1. Twenty fully reversed cycles of loading at a lateral force corresponding to the wind design force.

2. Three fully reversed cycles of loading at each of the following increments of the total design displacement: 0.25, 0.50, 0.75 and 1.0.

3. Three fully reversed cycles at the total maximum displacement.

4.  $15S_y/B$ , but not less than 10, fully reversed cycles of loading at 1.0 times the total design displacement.

If an isolator unit is also a vertical load-carrying element, then Item 2 of the sequence of cyclic tests specified above shall be performed for two additional vertical load cases:

$$(1) 1.2DL + 0.5LL + |E|$$

$$(2) 0.8DL - |E|$$

where  $DL$  and  $LL$  are defined in Chapter 16, Part III, and  $E$  is the earthquake load on an individual isolator unit acting in the vertical direction. In these tests, the combined vertical load shall be taken as the typical or average downward force on all isolator units of a common type and size.

**1661.2.4 Units dependent on loading rates.** If the force-deflection properties of the isolator units are dependent on the rate of loading, then each set of tests specified in Section 1661.2.3 shall be performed dynamically at a frequency equal to the inverse of the effective period of the isolated structure.

If reduced-scale prototype specimens are used to quantify rate-dependent properties of isolators, the reduced-scale prototype specimens shall be of the same type and material and be manufactured with the same processes and quality as full-scale prototypes, and shall be tested at a frequency that represents full-scale prototype loading rates.

The force-deflection properties of an isolator unit shall be considered to be dependent on the rate of loading if there is greater than a plus or minus 10 percent difference in the effective stiffness at the design displacement when tested at a frequency equal to the inverse of the effective period of the isolated structure and when tested at any frequency in the range of 0.1 to 2.0 times the inverse of the effective period of the isolated structure.

**1661.2.5 Units dependent on bilateral load.** If the force-deflection properties of the isolator units are dependent on bilateral load, then the tests specified in Sections 1661.2.3 and 1661.2.4 shall be augmented to include bilateral load at increments of the total design displacement 0.25 and 1.0, 0.50 and 1.0, 0.75 and 1.0, and 1.0 and 1.0.

**EXCEPTION:** If reduced-scale prototype specimens are used to quantify bilateral-load-dependent properties, then such scaled specimens shall be of the same type and material, and manufactured with the same processes and quality as full-scale prototypes.

The force-deflection properties of an isolator unit shall be considered to be dependent on bilateral load, if the bilateral and unilateral force-deflection properties have greater than a 10 percent difference in effective stiffness at the design displacement.

**1661.2.6 Downward vertical load.** Isolator units that carry vertical load shall be statically tested for maximum and minimum downward vertical load, at the total maximum displacement. In these tests, the combined vertical loads of  $1.2DL + 1.0LL + |E|$  shall be taken as the maximum downward force, and the combined vertical load of  $0.8DL - |E|$  shall be taken as the minimum downward force, on any one isolator unit of a common type and size.

**1661.2.7 Sacrificial wind-restraint systems.** If a sacrificial wind-restraint system is to be utilized, then the ultimate capacity shall be established by test.

**1661.2.8 Testing similar units.** The prototype tests are not required if an isolator unit is of similar size and of the same type and material as the prototype isolator unit that has been previously tested using the specified sequence of tests.

**1661.3 Determination of Force-deflection Characteristics.** The force-deflection characteristics of the isolation system shall be based on the cyclic load test results for each fully reversed cycle of loading.

The effective stiffness of an isolator unit shall be calculated for each cycle of loading as follows:

$$k_{eff} = \frac{F^+ - F^-}{\Delta^+ - \Delta^-} \quad (61-1)$$

where  $F^+$  and  $F^-$  are the maximum positive and maximum negative forces, respectively, and  $\Delta^+$  and  $\Delta^-$  are the maximum positive and maximum negative test displacements, respectively.

If the minimum effective stiffness is to be determined, then  $F_{min}^+$  and  $F_{min}^-$  shall be used in the equation.

If the maximum effective stiffness is to be determined, then  $F_{max}^+$  and  $F_{max}^-$  shall be used in the equation.

**1661.4 System Adequacy.** The performance of the test specimens shall be assessed as adequate if the following conditions are satisfied:

1. The force-deflection plots of all tests specified in Section 1661.2 have a positive incremental force-carrying capacity.
2. For each increment of test displacement specified in Section 1661.2.3, Item 2, and for each vertical load case specified in Section 1661.2.3:
  - 2.1 There is no greater than a 10 percent difference between the effective stiffness at each of the three cycles of test and the average value of effective stiffness for each test specimen.
  - 2.2 There is no greater than a 10 percent difference in the average value of effective stiffness of the two test specimens of a common type and size of the isolator unit over the required three cycles of test.
3. For each specimen there is no greater than a  $\pm 20$  percent change in the initial effective stiffness of each test specimen over the  $15S_f/B$ , but not less than 10, cycles of the test specified in Section 1661.2.3, Item 4.
4. For each specimen there is no greater than a 20 percent decrease in the initial effective damping over for the  $15S_f/B$ , but not less than 10, cycles of the test specified in Section 1661.2.3, Item 4.
5. All specimens of vertical load-carrying elements of the isolation system remain stable at the total maximum displacement for static load as prescribed in Section 1661.2.6.

#### 1661.5 Design Properties of the Isolation System.

**1661.5.1 Effective stiffness.** The minimum and maximum effective stiffnesses of the isolation system shall be determined as follows:

1. The value of  $k_{min}$  shall be based on the minimum effective stiffnesses of individual isolator units as established by the cyclic tests of Section 1661.2.3, Item 2, at a displacement amplitude equal to the design displacement.
2. The value of  $k_{max}$  shall be based on the maximum effective stiffnesses of individual isolator units as established by the cyclic tests of Section 1661.2.3, Item 2, at a displacement amplitude equal to the design displacement.
3. For isolator units that are found by the tests of Sections 1661.2.3, 1661.2.4 and 1661.2.5 to have force-deflection characteristics which vary with vertical load, rate of loading or bilateral load, respectively, the value of  $k_{max}$  shall be increased and the value of  $k_{min}$  shall be decreased, as necessary, to bound the effects of measured variation in effective stiffness.

**1661.5.2 Effective damping.** The effective damping ( $\beta$ ) of the isolation system shall be calculated as:

$$\beta = \frac{1}{2\pi} \left[ \frac{\text{Total Area}}{k_{max} D^2} \right] \quad (61-2)$$

where the total area shall be taken as the sum of the areas of the hysteresis loops of all isolator units and the hysteresis loop area of each isolator unit shall be taken as the minimum area of the three hysteresis loops established by the cyclic tests of Section 1661.2.3, Item 2, at a displacement amplitude equal to the design displacement.

**TABLE A-16-C—SITE COEFFICIENTS FOR SEISMIC-ISOLATED STRUCTURES**

<sup>1</sup>See Table 16-J for a description of soil profile types and related requirements.

**TABLE A-16-D—NEAR-FIELD COEFFICIENT, *N***

CLOSEST DISTANCE, $d_F$ , TO ACTIVE FAULT	MAXIMUM CAPABLE EARTHQUAKE MAGNITUDE, $M_{MCE}$ , OF ACTIVE FAULT <sup>1,2</sup>		
	$M_{MCE} \geq 8.0$	$M_{MCE} = 7.0$	$M_{MCE} \leq 6.0$
$d_F \geq 15$ km	1.0	1.0	1.0
$d_F = 10$ km	1.2	1.0	1.0
$d_F \leq 5$ km	1.5	1.3	1.1

<sup>1</sup>Location and maximum capable earthquake magnitude,  $M_{MCE}$ , of active faults shall be established for properly substantiated geotechnical data (e.g., most recent mapping of active faults by the United States Geological Survey or the California Division of Mines and Geology).

<sup>2</sup>The near-field site response coefficient shall be based on linear interpolation of values of the closest distance,  $d_F$ , and maximum capable magnitude,  $M_{MCE}$ , other than those given.

**TABLE A-16-E—DAMPING COEFFICIENT, *B***

EFFECTIVE DAMPING, $\beta$ (percentage of critical) <sup>1,2</sup>	<i>B</i> FACTOR
$\leq 2$	0.8
5	1.0
10	1.2
20	1.5
30	1.7
40	1.9
$\geq 50$	2.0

<sup>1</sup>The damping coefficient shall be based on the effective damping of the isolation system determined in accordance with the requirements of Section 1661.5.

<sup>2</sup>The damping coefficient shall be based on linear interpolation for effective damping values other than those given.

TABLE A-16-F—STRUCTURAL SYSTEMS ABOVE THE ISOLATION INTERFACE

BASIC STRUCTURAL SYSTEM <sup>1</sup>	LATERAL LOAD-RESISTING SYSTEM DESCRIPTION	$R_w$ <sup>2</sup>	$H$ <sup>3</sup>
			× 304.8 for mm
1. Bearing wall system	1.1. Light-framed walls with shear panels		
	1.1.1 Plywood walls for structures three stories or less	2.6	65
	1.1.2 All other light-framed walls	2.2	65
	1.2. Shear walls		
	1.2.1. Concrete	2.6	160
	1.2.2. Masonry	2.6	160
	1.3. Light-steel-framed bearing walls with tension-only bracing	1.6	65
	1.4. Braced frames where bracing carries gravity loads		
	1.4.1. Steel	1.8	160
	1.4.2. Concrete <sup>4</sup>	1.5	
1.4.3. Heavy timber	1.5	65	
2. Building frame system	2.1. Steel eccentric-braced frame (EBF)	3.0	240
	2.2. Light-framed walls with shear panels		
	2.2.1. Plywood walls for structures three stories or less	2.6	65
	2.2.2. All other light-framed walls	2.2	65
	2.3. Shear walls		
	2.3.1. Concrete	3.0	240
	2.3.2. Masonry	3.0	160
	2.4. Concentric-braced frames		
	2.4.1. Steel	2.2	160
	2.4.2. Concrete <sup>4</sup>	2.6	
2.4.3. Heavy timber	2.6	65	
3. Moment-resisting frame system	3.1. Special moment-resisting frames (SMRF)		
	3.1.1. Steel	3.0	NL <sup>5</sup>
	3.1.2. Concrete	3.0	NL
	3.2. Concrete intermediate moment-resisting frames (IMRF) <sup>6</sup>	2.2	
	3.3. Ordinary moment-resisting frames		
	3.3.1. Steel	1.8	160
3.3.2. Concrete <sup>4</sup>	1.5		
4. Dual system	4.1. Shear walls		
	4.1.1. Concrete with SMRF	3.0	NL
	4.1.2. Concrete with concrete IMRF <sup>5,6</sup>	2.6	160
	4.1.3. Masonry with SMRF	3.0	160
	4.1.4. Masonry with concrete IMRF <sup>4</sup>	2.6	
	4.2. Steel EBF with steel SMRF	2.6	NL
	4.3. Concrete-braced frames		
	4.3.1. Steel with steel SMRF	2.2	NL
	4.3.2. Concrete with concrete SMRF <sup>4</sup>	2.2	
	4.3.3. Concrete with concrete IMRF <sup>4</sup>	1.8	
5. Undefined systems	See Section 1627.9.2		

<sup>1</sup>Basic structural systems are defined in Section 1627.6.

<sup>2</sup>See Section 1628.3 for combination of structural system.

<sup>3</sup> $H$  — Height limit applicable to Seismic Zones 3 and 4. See Section 1627.7 for exceptions.

<sup>4</sup>Prohibited in Seismic Zones 3 and 4.

<sup>5</sup>NL — No limit.

<sup>6</sup>Prohibited in Seismic Zones 3 and 4, except as permitted in Section 1632.2.

TABLE A-16-G—MAXIMUM CAPABLE EARTHQUAKE RESPONSE COEFFICIENT,  $M_M$

SEISMIC ZONE	RESPONSE REGION <sup>1,2</sup>	
	Constant Acceleration	Constant Velocity
4	1.25	1.25
3	1.33	1.50

<sup>1</sup>Except for construction of design spectra, as required in Section 1655.4, the value of  $M_M$  shall be that specified for constant velocity. The value of  $M_M$  for sites not located in Seismic Zone 3 or 4 shall be taken as the ratio of maximum capable earthquake and design basis earthquake spectra at the effective period,  $T_I$ , of the isolated structure.

<sup>2</sup>For construction of design spectra, as required in Section 1655.4, the value of  $M_M$  specified for constant acceleration shall apply to all periods from 0 second to the transition period (i.e., 0.4 second for Soil Type  $S_1$ , 0.6 second for Soil Type  $S_2$  and 0.9 second for Soil Type  $S_3$ ), and the value of  $M_M$  specified for constant velocity shall apply to all periods greater than the transition period. The product  $M_M Z N$  in the constant velocity region need not exceed the product  $M_M Z N$  at the transition period.

## Appendix Chapter 18 WATERPROOFING AND DAMPPROOFING FOUNDATIONS

### SECTION 1819 — SCOPE

Walls, or portions thereof, retaining earth and enclosing interior spaces and floors below grade shall be waterproofed or dampproofed according to this appendix chapter.

**EXCEPTION:** Walls enclosing crawl spaces.

### SECTION 1820 — GROUNDWATER TABLE INVESTIGATION

A subsurface soils investigation shall be made in accordance with Section 1804.3, Item 3, to determine the possibility of the groundwater table rising above the proposed elevation of the floor or floors below grade. The building official may require that this determination be made by an engineer or architect licensed by the state to practice as such.

**EXCEPTIONS:** 1. When foundation waterproofing is provided.

2. When dampproofing is provided and the building official finds that there is satisfactory data from adjacent areas to demonstrate that groundwater has not been a problem.

### SECTION 1821 — DAMPPROOFING REQUIRED

Where the groundwater investigation required by Section 1820 indicates that a hydrostatic pressure caused by the water table will not occur, floors and walls shall be dampproofed and a subsoil drainage system shall be installed in accordance with this appendix chapter.

**EXCEPTION:** Wood foundation systems shall be constructed in accordance with Chapter 18, Division II.

### SECTION 1822 — FLOOR DAMPPROOFING

**1822.1 General.** Dampproofing materials shall be installed between the floor and base materials required by Section 1824.2.

**EXCEPTION:** Where a separate floor is provided above a concrete slab, the dampproofing may be installed on top of the slab.

**1822.2 Dampproofing Materials.** Dampproofing installed beneath the slab shall consist of not less than 6-mil (0.152 mm) polyethylene, or other approved methods or materials. When permitted to be installed on top of the slab, dampproofing shall consist of not less than 4-mil (0.1 mm) polyethylene, mopped-on bitumen or other approved methods or materials. Joints in membranes shall be lapped and sealed in an approved manner.

### SECTION 1823 — WALL DAMPPROOFING

**1823.1 General.** Dampproofing materials shall be installed on the exterior surface of walls, and shall extend from a point 6 inches (152 mm) above grade, down to the top of the spread portion of the footing.

**1823.2 Surface Preparation.** Prior to application of dampproofing materials on concrete walls, fins or sharp projections that may pierce the membrane shall be removed and all holes and recesses resulting from the removal of form ties shall be sealed with a dry-pack mortar, bituminous material, or other approved methods or materials.

**1823.3 Dampproofing Materials.** Wall dampproofing shall consist of a bituminous material, acrylic modified cement base coating, any of the materials permitted for waterproofing in Section

1827.4, or other approved methods or materials. When such materials are not approved for direct application to unit masonry, the wall shall be parged on the exterior surface below grade with not less than  $\frac{3}{8}$  inch (10 mm) of portland cement mortar.

## SECTION 1824 — OTHER DAMPPROOFING REQUIREMENTS

**1824.1 Subsoil Drainage System.** When dampproofing is required, a base material shall be installed under the floor and a drain shall be installed around the foundation perimeter in accordance with this subsection.

**EXCEPTION:** When the finished ground level is below the floor level for more than 25 percent of the perimeter of the building, the base material required by Section 1824.2 need not be provided and the foundation drain required by Section 1824.3 need be provided only around that portion of the building where the ground level is above the floor level.

**1824.2 Base Material.** Floors shall be placed over base material not less than 4 inches (102 mm) in thickness consisting of gravel or crushed stone containing not more than 10 percent material that passes a No. 4 sieve (4.75 mm).

**1824.3 Foundation Drain.** The drain shall consist of gravel, crushed stone or drain tile.

Gravel or crushed stone drains shall contain not more than 10 percent material that passes a No. 4 sieve (4.75 mm). The drain shall extend a minimum of 12 inches (305 mm) beyond the outside edge of the footing. The depth shall be such that the bottom of the drain is not higher than the bottom of the base material under the floor, and the top of the drain is not less than 6 inches (152 mm) above the spread portion of the footing. The top of the drain shall be covered with an approved filter membrane material.

When drain tile or perforated pipe is used, the invert of the pipe or tile shall be not higher than the floor elevation. The top of joints or the top of perforations shall be protected with an approved filter membrane material. The pipe or tile shall be placed on not less than 2 inches (51 mm) of gravel or crushed stone complying with this section and covered with not less than 6 inches (152 mm) of the same material.

**1824.4 Drainage Disposal.** The floor base and foundation perimeter drain shall discharge by gravity or mechanical means into an approved drainage system.

**EXCEPTION:** Where a site is located in well-drained gravel or sand-gravel mixture soils, a dedicated drainage system need not be provided.

## SECTION 1825 — WATERPROOFING REQUIRED

Where the groundwater investigation required by Section 1820 indicates that a hydrostatic pressure caused by the water table does exist, walls and floors shall be waterproofed in accordance with this appendix chapter.

**EXCEPTIONS:** 1. When the groundwater table can be lowered and maintained at an elevation not less than 6 inches (152 mm) below the bottom of the lowest floor, dampproofing provisions in accordance with Section 1821 may be used in lieu of waterproofing.

The design of the system to lower the groundwater table shall be based on accepted principles of engineering which shall consider, but not necessarily be limited to, the permeability of the soil, the rate at which water enters the drainage system, the rated capacity of pumps, the head against which pumps are to pump, and the rated capacity of the disposal area of the system.

2. Wood foundation systems constructed in accordance with Chapter 18, Division II, are to be provided with additional moisture-control measures as specified in Section 29.303.

## SECTION 1826 — FLOOR WATERPROOFING

**1826.1 General.** Floors required to be waterproofed shall be of concrete designed to withstand anticipated hydrostatic pressure.

**1826.2 Waterproofing Materials.** Waterproofing of floors shall be accomplished by placing under the slab a membrane of rubberized asphalt, polymer-modified asphalt, butyl rubber, neoprene, or not less than 6-mil (0.15 mm) polyvinyl chloride or polyethylene, or other approved materials capable of bridging nonstructural cracks. Joints in the membrane shall be lapped not less than 6 inches (152 mm) and sealed in an approved manner.

### **SECTION 1827 — WALL WATERPROOFING**

**1827.1 General.** Walls required to be waterproofed shall be of concrete or masonry designed to withstand the anticipated hydrostatic pressure and other lateral loads.

**1827.2 Wall Preparation.** Prior to the application of waterproofing materials on concrete or masonry walls, the wall surfaces shall be prepared in accordance with Section 1823.2.

**1827.3 Where Required.** Waterproofing shall be applied from a point 12 inches (305 mm) above the maximum elevation of the groundwater table down to the top of the spread portion of the footing. The remainder of the wall located below grade shall be dampproofed with materials in accordance with Section 1823.3.

**1827.4 Waterproofing Materials.** Waterproofing shall consist of rubberized asphalt, polymer-modified asphalt, butyl rubber, or other approved materials capable of bridging nonstructural cracks. Joints in the membrane shall be lapped and sealed in an approved manner.

**1827.5 Joints.** Joints in walls and floors, and between the wall and floor, and penetrations of the wall and floor shall be made watertight using approved methods and materials.

### **SECTION 1828 — OTHER DAMPPROOFING AND WATERPROOFING REQUIREMENTS**

**1828.1 Placement of Backfill.** The excavation outside the foundation shall be backfilled with soil which is free of organic material, construction debris and large rocks. The backfill shall be placed in lifts and compacted in a manner which does not damage the waterproofing or dampproofing material or structurally damage the wall.

**1828.2 Site Grading.** The ground immediately adjacent to the foundation shall be sloped away from the building at not less than 1 unit vertical in 12 units horizontal (8.3% slope) for a minimum distance of 6 feet (1829 mm) measured perpendicular to the face of the wall or an approved alternate method of diverting water away from the foundation shall be used. Consideration shall be given to possible additional settlement of the backfill when establishing final ground level adjacent to the foundation.

**1828.3 Erosion Protection.** Where water impacts the ground from the edge of the roof, downspout, scupper, valley, or other rainwater collection or diversion device, provisions shall be used to prevent soil erosion and direct the water away from the foundation.

## Appendix Chapter 19

### PROTECTION OF RESIDENTIAL CONCRETE EXPOSED TO FREEZING AND THAWING

#### SECTION 1928 — GENERAL

**1928.1 Purpose.** The purpose of this appendix is to provide minimum standards for the protection of residential concrete exposed to freezing and thawing conditions.

**1928.2 Scope.** The provisions of this appendix apply to concrete used in buildings of Groups M and R Occupancies which are three stories or less in height.

**1928.3 Special Provisions.** Normal-weight aggregate concrete used in buildings of Groups M and R Occupancies three stories or less in height which are subject to deicer chemicals or freezing and thawing conditions as determined from Figure A-19-1 shall comply with the requirements of Table A-19-A.

**TABLE A-19-A—MINIMUM SPECIFIED COMPRESSIVE STRENGTH OF CONCRETE<sup>1</sup>**

TYPE OR LOCATION OF CONCRETE CONSTRUCTION	MINIMUM SPECIFIED COMPRESSIVE STRENGTH <sup>2</sup> ( $f_c$ )		
	× 6.89 for kPa		
	Weathering Potential <sup>3</sup>		
	Negligible	Moderate	Severe
Basement walls and foundations not exposed to the weather	2,500	2,500	2,500 <sup>4</sup>
Basement slabs and interior slabs on grade, except garage floor slabs	2,500	2,500	2,500 <sup>4</sup>
Basement walls, foundation walls, exterior walls and other vertical concrete work exposed to the weather	2,500	3,000 <sup>5</sup>	3,000 <sup>5</sup>
Porches, carport slabs and steps exposed to the weather, and garage floor slabs	2,500	3,000 <sup>5</sup>	3,500 <sup>5</sup>

<sup>1</sup>Increases in compressive strength above those used in the design shall not cause implementation of the special inspection provisions of Section 1701.5, Item 1.

<sup>2</sup>At 28 days, pounds per square inch (kPa).

<sup>3</sup>See Figure A-19-1 for weathering potential.

<sup>4</sup>Concrete in these locations which may be subject to freezing and thawing during construction shall be air-entrained concrete in accordance with Footnote 5.

<sup>5</sup>Concrete shall be air entrained. Total air content (percentage by volume of concrete) shall not be less than 5 percent or more than 7 percent.

## Appendix Chapter 21

### PRESCRIPTIVE MASONRY CONSTRUCTION IN HIGH-WIND AREAS

#### SECTION 2112 — GENERAL

**2112.1 Purpose.** The provisions of this chapter are intended to promote public safety and welfare by reducing the risk of wind-induced damages to masonry construction.

**2112.2 Scope.** The requirements of this chapter shall apply to masonry construction in buildings when all of the following conditions are met:

1. The building is located in an area with a basic wind speed from 80 through 110 miles per hour (mph) (129 km/h through 177 km/h).
2. The building is located in Seismic Zone 0, 1 or 2.
3. The building does not exceed two stories.
4. Floor and roof joists shall be wood or steel or of precast hollowcore concrete planks with a maximum span of 32 feet (9754 mm) between bearing walls. Masonry walls shall be provided for the support of steel joists or concrete planks.
5. The building is of regular shape.

**2112.3 General.** The requirements of Chapter 21 are applicable except as specifically modified by this chapter. Other methods may be used provided a satisfactory design is submitted showing compliance with the provisions of Chapter 16, Part II, and other applicable provisions of this code.

Wood floor, roof and interior walls shall be constructed as specified in Appendix Chapter 23 and as further regulated in this section.

In areas where the wind speed exceeds 110 mph (177 km/h), masonry buildings shall be designed in accordance with Chapter 16, Part II, and other applicable provisions of this code.

Buildings of unusual shape or size, or split-level construction, shall be designed in accordance with Chapter 16, Part II, and other applicable provisions of this code.

In addition to the other provisions of this chapter, foundations for buildings in areas subject to wave action or tidal surge shall be designed in accordance with approved national standards.

All metal connectors and fasteners used in exposed locations or in areas otherwise subject to corrosion shall be of corrosion-resistant or noncorrosive material. When the terms "corrosion resistant" or "noncorrosive" are used in this chapter, they shall mean having a corrosion resistance equal to or greater than a hot-dipped galvanized coating of 1.5 ounces of zinc per square foot (3.95 g/m<sup>2</sup>) of surface area. When an element is required to be corrosion resistant or noncorrosive, all of its parts, such as screws, nails, wire, dowels, bolts, nuts, washers, shims, anchors, ties and attachments shall be corrosion resistant.

#### **2112.4 Materials.**

**2112.4.1 General.** All masonry materials shall comply with Section 2102.2 as applicable for standards of quality.

#### **2112.4.2 Hollow-unit masonry.**

1. Exterior concrete block shall be a minimum of Grade N-II with a compressive strength of not less than 1,900 pounds per square inch (psi) (13 091 kPa) on the net area.
2. Interior concrete block shall be a minimum of Grade S-II with a compressive strength of not less than 700 psi (4823 kPa) on the gross area.

3. Exterior clay or shale hollow brick shall have a compressive strength of not less than 2,500 psi (17 225 kPa) on the net area. Such hollow brick shall be at least Grade MW except that where subject to severe freezing it shall be Grade SW.

4. Interior clay or shale hollow brick shall be Grade MW with a compressive strength of 2,000 psi (13 780 kPa) on the net area.

#### **2112.4.3 Solid masonry.**

1. Exterior clay or shale bricks shall have a compressive strength of not less than 2,500 psi (17 225 kPa) on the net area.

2. Exterior clay or shale bricks shall be Grade MW, except that where subject to severe freezing they shall be Grade SW.

3. Interior clay or shale bricks shall have a compressive strength of not less than 2,000 psi (13 780 kPa).

**2112.4.4 Grout.** Grout shall achieve a compressive strength of not less than 2,000 psi (13 780 kPa).

**2112.4.5 Mortar.** Mortar for exterior walls and for interior shear walls shall be Type M or Type S.

**2112.5 Construction Requirements.** Grouted cavity wall and block wall construction shall comply with Section 2104.

Unburned clay masonry and stone masonry shall not be used.

**2112.6 Foundations.** Footings shall have a thickness of not less than 8 inches (203 mm) and shall comply with Tables A-21-A-1 and A-21-A-2 for width. See Figure A-21-1 for other applicable details.

Footings shall extend 18 inches (457 mm) below the undisturbed ground surface or the frost depth, whichever is deeper.

Foundation stem walls shall be as wide as the wall they support. They shall be reinforced with reinforcing bar sizes and spacing to match the reinforcement of the walls they support.

Basement and other below-grade walls shall comply with Table A-21-B.

**2112.7 Drainage.** Basement walls and other walls or portions thereof retaining more than 3 feet (914 mm) of earth and enclosing interior spaces or floors below grade shall have a minimum 4-inch-diameter (102 mm) footing drain as illustrated in Table A-21-B and Figure A-21-3.

The finish elevations around the building shall be graded to provide a slope away from the building of not less than  $\frac{1}{4}$  unit vertical to 12 units horizontal (2% slope).

#### **2112.8 Wall Construction.**

**2112.8.1 Minimum thickness.** Reinforced exterior bearing walls shall have a minimum 8-inch (203 mm) nominal thickness. Interior masonry nonbearing walls shall have a minimum 6-inch (152 mm) nominal thickness. Unreinforced grouted brick walls shall have a minimum 10-inch (254 mm) thickness. Unreinforced hollow-unit and solid masonry shall have a minimum 8-inch (203 mm) nominal thickness.

**EXCEPTION:** In buildings not more than two stories or 26 feet (7924.8 mm) in height, masonry walls may be of 8-inch (203 mm) nominal thickness. Solid masonry walls in one-story buildings may be of 6-inch (153 mm) nominal thickness when not over 9 feet (2743 mm) in height, provided that when gable construction is used an additional 6 feet (1829 mm) are permitted to the peak of the gable.

**2112.8.2 Lateral support and height.** All walls shall be laterally supported at the top and bottom. The maximum unsupported height of bearing walls or other masonry walls shall be 12 feet (3658 mm). Gable-end walls may be 15 feet (4572 mm) at their peak.

Wood-framed gable-end walls on buildings shall comply with Table A-21-I and Figure A-21-17 or A-21-18.

**2112.8.3 Walls in Seismic Zone 2 and use of stack bond.** In Seismic Zone 2, walls shall comply with Figure A-21-B as a minimum. Walls with stack bond shall be designed.

**2112.8.4 Lintels.** The span of lintels over openings shall not exceed 12 feet (3658 mm), and lintels shall be reinforced. The reinforcement bars shall extend not less than 2 feet (610 mm) beyond the edge of opening and into lintel supports.

Lintel reinforcement shall be within fully grouted cells in accordance with Table A-21-E.

**2112.8.5 Reinforcement.** Walls shall be reinforced as shown in Tables A-21-C-1 through A-21-C-5 and Figure A-21-2.

**2112.8.6 Anchorage of walls to floors and roofs.** Anchors between walls and floors or roofs shall be embedded in grouted cells or cavities and shall conform to Section 2112.9.

**2112.9 Floor and Roof Systems.** The anchorage of wood roof systems which are supported by masonry walls shall comply with Appendix Sections 2365.5.1 and 2365.5.8, Table A-21-D and Figure A-21-7.

Wood roof and floor systems which are supported by ledgers at the inside face of masonry walls shall comply with Table A-21-D, Part I.

The ends of joist girders shall extend a distance of not less than 6 inches (152 mm) over masonry or concrete supports and be attached to a steel bearing plate. This plate is to be located not more than  $\frac{1}{2}$  inch (13 mm) from the face of the wall and is to be not less than 9 inches (229 mm) wide perpendicular to the length of the joist girder. Ends of joist girders resting on steel bearing plates on masonry or structural concrete shall be attached thereto with a minimum of two  $\frac{1}{4}$ -inch (6.4 mm) fillet welds 2 inches (51 mm) long, or with two  $\frac{3}{4}$ -inch (19 mm) bolts.

Ends of joist girders resting on steel supports shall be connected thereto with a minimum of two  $\frac{1}{4}$ -inch (6.4 mm) fillet welds 2 inches (51 mm) long, or with two  $\frac{3}{4}$ -inch (19 mm) bolts. In steel frames, joist girders at column lines shall be field bolted to the columns to provide lateral stability during construction.

Steel joist roof and floor systems shall be anchored in accordance with Table A-21-H.

Wall ties spaced as shown in Table A-21-D, Part II, shall connect to framing or blocking at roofs and walls. Wall ties shall enter grouted cells or cavities and shall be  $1\frac{1}{8}$ -inch (29 mm) minimum width by 0.036 inch (0.91 mm) (No. 20 galvanized sheet gage) sheet steel.

Roof and floor hollow-core precast plank systems shall be anchored in accordance with Table A-21-G.

Roof uplift anchorage shall enter a grouted bond beam reinforced with horizontal bars as shown in Tables A-21-C-1 through A-21-C-5 and Figure A-21-7.

#### **2112.10 Lateral Force Resistance.**

**2112.10.1 Complete load path and uplift resistance.** Strapping, approved framing anchors, and mechanical fasteners, bond beams, and vertical reinforcement shall be installed to provide a continuous tie from the roof to the foundation system. (See Figure A-21-8.) In addition, roof and floor systems, masonry shear walls, or masonry or wood cross walls shall provide lateral stability.

**2112.10.2 Floor and roof diaphragms.** Floor and roof diaphragms shall be connected to masonry walls as shown in Table A-21-F, Part II.

Gabled and sloped roof members not supported at the ridge shall be tied by ceiling joists or equivalent lateral ties located as close to where the roof member bears on the wall as is practically possible, at not more than 48 inches (1219 mm) on center. Collar ties shall not be used for these lateral ties. (See Figure A-21-17 and Table A-21-I.)

**2112.10.3 Walls.** Masonry walls shall be provided around all sides of floor and roof systems in accordance with Figure A-21-9 and Table A-21-F.

The cumulative length of exterior masonry walls along each side of the floor or roof systems shall be at least 20 percent of the parallel dimension. Required elements shall be without openings and shall not be less than 48 inches (1219 mm) in width.

Interior cross walls (nonbearing) at right angles to bearing walls shall be provided when the length of the building perpendicular to the span of the floor or roof framing exceeds twice the distance between shear walls or 32 feet (9754 mm), whichever is greater. Cross walls, when required, shall conform to Section 2112.10.4.

**2112.10.4 Interior cross walls.** When required by Table A-21-F, Part I, masonry walls shall be at least 6 feet (1829 mm) long and reinforced with 9 gage wire joint reinforcement spaced not more than 16 inches (406 mm) on center. Cross walls shall comply with Footnote 3 of Table A-21-F, Part I.

Interior wood stud walls may be used to resist the wind load from one-story masonry buildings in areas where the basic wind speed is 100 mph (161 km/h), Exposure C or less, and 110 mph (177 km/h), Exposure B. When wood stud walls are so used, they shall:

1. Be perpendicular to exterior masonry walls at 15 feet (4572 mm) or less on center.
2. Be at least 8 feet (2438 mm) long without openings and be sheathed on at least one side with  $1\frac{5}{32}$ -inch (12 mm) wood structural panel nailed with 8d common or galvanized box nails at 6 inches (152 mm) on center edge and field nailing. All unsupported edges of wood structural panels shall be blocked.
3. Be connected to wood blocking or wood joists below with two 16d nails at 16 inches (406 mm) on center through their sill plates. They shall be connected to footings with  $\frac{1}{2}$ -inch-diameter (13 mm) bolts at 3 feet 6 inches (1067 mm) on center.
4. Connect to wood roof systems as outlined in Table A-21-F, Part II, as a cross wall. Wood structural panel roof sheathing shall have all unsupported edges blocked.

## WEATHERING REGIONS FOR RESIDENTIAL CONCRETE

**Weathering Regions (Weathering Index)**

FIGURE A-19-1

**Notes:**

<sup>1</sup>The three exposures are:

- A. Severe—Outdoor exposure in a cold climate where concrete may be exposed to the use of deicing salts or where there may be a continuous presence of moisture during frequent cycles of freezing and thawing. Examples are pavements, driveways, walks, curbs, steps, porches and slabs in unheated garages. Destructive action from deicing salts may occur either from direct application or from being carried onto an unsalted area from a salted area, such as on the undercarriage of a car traveling on a salted street but parked on an unsalted driveway or garage slab.
- B. Moderate—Outdoor exposure in a climate where concrete will not be exposed to the application of deicing salts but will occasionally be exposed to freezing and thawing.
- C. Mild—Any exposure where freezing and thawing in the presence of moisture is rare or totally absent.

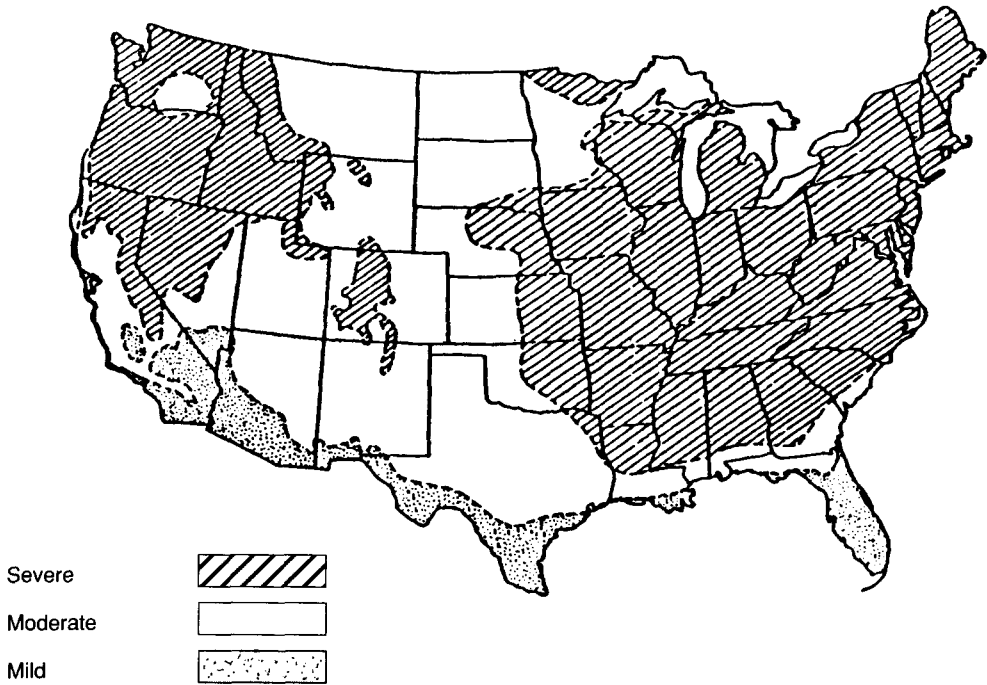
<sup>2</sup>Data needed to determine the weathering index for any locality may be found or estimated from the tables of Local Climatological Data, published by the Weather Bureau, U.S. Department of Commerce.

<sup>3</sup>The weathering regions map provides the location of severe, moderate and mild winter weathering areas as they occur in the United States (Alaska and Hawaii are classified as severe and mild, respectively). The map cannot be precise. This is especially true in mountainous areas where conditions change dramatically within very short distances. It is intended to classify as severe any area in which weathering conditions may cause deicing salt to be used, either by individuals or for street or highway maintenance. These conditions are significant snowfall combined with extended periods during which there is little or no natural thawing. If there is any doubt about which of two regions is applicable, the more severe exposure should be selected.

<sup>4</sup>The Weathering Index:

Severe—As a guideline, the number of days during which the temperature does not rise above 32°F. (0°C.) is multiplied by the inches of snowfall. An index of 150 or more is classified as severe. Cold, humid climates may be more severe than cold, dry climates for a given index.

Moderate, Mild—Multiply the inches of precipitation times the number of days the temperature registers below 32°F. (0°C.) Use the occurrence between the first day in the fall and the last day in the spring that the temperature registers below 32°F. (0°C.) An index above 200 is moderate. An index below 200 is mild.

**TABLE A-21-A-1—EXTERIOR FOUNDATION REQUIREMENTS FOR MASONRY BUILDINGS WITH 6- AND 8-INCH-THICK WALLS (Wood or Steel Framing) (Width of Footings in Inches)<sup>1,2,3</sup>**  
 See Figure A-21-1 for typical details.

WALL HEIGHT (feet)	SPAN TO BEARING WALLS (feet)	TWO-STORY BUILDINGS								
		Roof Live Load <sup>4</sup> (psf)								
		× 0.0479 for kN/m <sup>2</sup>								
		20			30			40		
		Plus Floor Live Load <sup>5</sup> (psf)								
		ONE-STORY BUILDINGS								
		Roof Live Load <sup>4</sup>			× 0.0479 for kN/m <sup>2</sup>					
		× 0.0479 for kN/m <sup>2</sup>								
		20 psf (inches)	30 psf (inches)	40 psf (inches)	50	100	50	100	50	100
		Minimum Width of Footing (inches)								
× 304.8 for mm		× 25.4 for mm								
8	8	12			12	12	12	12	12	12
	16				12	14	12	14	12	14
	24				14	18	14	18	16	18
	32				16	20	18	20	18	20
10	8	12			12	12	12	12	12	12
	16				14	16	14	16	14	16
	24				16	20	16	18	16	20
	32				20	24	20	22	20	24
12	8	12	12	12	12	14	12	14	12	14
	16	12	12	12	16	18	16	16	14	16
	24	12	12	14	18	20	18	20	18	20
	32	12	14	16	20	22	22	22	22	24

<sup>1</sup>For buildings with under-floor space or basements, footing thickness is to be a minimum of 12 inches (305 mm). It shall be reinforced with No. 4 bars at 24 inches (610 mm) on center when its width is required to be 18 inches (457 mm) or larger and it supports more than the roof and one floor.

<sup>2</sup>Soil to be at least Class 4 as shown in Table 18-I-D.

<sup>3</sup>Footings are a minimum of 10 inches (254 mm) thick for a one-story building and 12 inches (305 mm) thick for a two-story building. Bottom of footing to be 18 inches (457 mm) below grade or the frost depth, whichever is deeper. Footing to be reinforced with No. 4 bars at 24 inches (610 mm) on center when supporting more than the roof and one floor.

<sup>4</sup>From Table 21-C or local snow load tables. For areas without snow loads use 20 pounds per square foot (0.96 kN/m<sup>2</sup>).

<sup>5</sup>From Table 21-A. For intermediate floor loads go to next higher value.

**TABLE A-21-A-2—INTERIOR FOUNDATION REQUIREMENTS FOR MASONRY BUILDINGS WITH 6- AND 8-INCH-THICK WALLS (Wood or Steel Framing) (Width of Footings in Inches)<sup>1,2,3,4</sup> See Figure A-21-1 for typical details.**

WALL HEIGHT (feet)	SPAN TO BEARING WALLS (feet)	TWO-STORY BUILDINGS								
		ONE-STORY BUILDINGS			Plus Floor Live Load <sup>6</sup> (psf)					
		Roof Live Load <sup>5</sup>			Roof Live Load <sup>5</sup> (psf)					
		× 0.0479 for kN/m <sup>2</sup>			× 0.0479 for kN/m <sup>2</sup>					
		20 psf (inches)	30 psf (inches)	40 psf (inches)	20	30	40			
					50	100	50	100	50	100
		Minimum Width of Footing (inches)								
× 304.8 for mm		× 25.4 for mm								
8	8	12	12	12	12	14	12	14	12	14
	16	12	12	12	16	20	18	20	18	22
	24	12	12	14	20	26	22	28	22	28
	32	14	14	16	24	28	26	32	28	34
10	8	12	12	12	14	16	14	16	14	16
	16	12	12	12	20	24	20	22	20	22
	24	12	14	14	22	28	22	28	22	28
	32	14	14	16	26	34	26	32	28	34
12	8	12	12	12	14	16	16	18	16	18
	16	12	14	16	20	24	20	22	20	22
	24	14	14	16	24	28	22	28	24	28
	32	16	16	18	28	30	28	32	28	34

<sup>1</sup>For buildings with under-floor space or basements, footing thickness is to be a minimum of 12 inches (305 mm). It shall be reinforced with No. 4 bars at 24 inches (610 mm) on center when its width is required to be 18 inches (457 mm) or larger and it supports more than the roof and one floor.  
<sup>2</sup>Soil to be at least Class 4 as shown in Table 18-1-A.  
<sup>3</sup>Footings are 10 inches (254 mm) thick for up to 24 inches (610 mm) wide and 12 inches (305 mm) thick for up to 34 inches (864 mm) wide. Footings shall be reinforced with No. 4 bars at 24 inches (610 mm) on center when supporting more than the roof and one floor.  
<sup>4</sup>These interior footings support roof-ceiling or floors or both for a distance on each side equal to the span length shown. A tributary width equal to the span length may be used.  
<sup>5</sup>From Table 16-C or local snow load tables. For areas without snow loads use 20 pounds per square foot (0.96 kN/m<sup>2</sup>).  
<sup>6</sup>From Table 16-A. For intermediate floor loads go to next higher value.

**TABLE A-21-B—VERTICAL REINFORCEMENT AND TOP RESTRAINT FOR VARIOUS HEIGHTS OF BASEMENT AND OTHER BELOW-GRADE WALLS**

DESIGN ASSUMPTIONS						
A. Materials:						
1. <b>Concrete Masonry Units</b> —Grade hollow load bearing units conforming to Section 2112.4.2 for strength of units should not be less than that required for applicable $f'_m$ .						
2. <b>Mortar</b> —Type M, 2,500 psi (17 240 kPa) strength.						
3. <b>Corefill</b> —Fine or coarse grout (U.B.C. Standard 21-19) with an ultimate strength (28 days) of at least 2,500 psi (17 240 kPa).						
4. <b>Reinforcement</b> —Deformed billet-steel bars.						
5. 1,500 psf (71.8 kPa) soil bearing required. <sup>1</sup>						
B. Allowable stresses in accordance with Section 2106 and Table 21-M.						
Soil Equiv.-fluid wt. = 30 pcf <sup>1</sup> (4.71 kN/m <sup>3</sup> )			Vertical Reinforcement with Axial Compressive Load ( <i>P</i> ) Equal to or Less Than 5,000 lb./lin. ft. (72.92 kN/m)			
Wall Depth Below Grade <i>h</i> (feet)	Floor Connection <sup>2,3</sup>		$f'_m = 1,500$ psi (10 335 kPa)			
	Wood Floor		Spacing of Reinforcement (inches) <sup>4</sup>			
× 304.8 for mm	Bolt and Spacing	Angle Clip Spacing	× 25.4 for mm			
8-Inch Walls			No. 3	No. 4	No. 5	
× 25.4 for mm						
4	1/2" at 60"	48" o.c.	24	40	56	
5	1/2" at 40"	32" o.c.	16	24	40	
6	5/8" at 32"	20" o.c.	—	16	24	
10-Inch Walls			Spacing of Reinforcement (inches)			
× 25.4 for mm			× 25.4 for mm			
			No. 4	No. 5	No. 6	No. 7
6	5/8" at 32"	20" o.c.	40	56	64	72
7	5/8" at 24"	16" o.c.	24	40	48	56
9	3/4" at 20"	2 at 24" o.c.	16	24	32	40
12-Inch Walls			Spacing of Reinforcement (inches)			
× 25.4 for mm			× 25.4 for mm			
			No. 4	No. 5	No. 6	No. 7
7	5/8" at 24"	16" o.c.	40	56	80	80
8	3/4" at 20"	2 at 24" o.c.	32	48	56	64
9	7/8" at 18"	2 at 18" o.c.	24	40	48	48
10	1" at 16"	2 at 16" o.c.	16	32	40	40

<sup>1</sup>Soil type is at least Class 4 as shown in Table 18-I-A.  
<sup>2</sup>There shall be no backfill placed until after the wall is anchored to the floor and seven days have passed after grouting.  
<sup>3</sup>For Figure A-21-4 only.  
<sup>4</sup>See Figure A-21-5 for placement of reinforcement.

**TABLE A-21-C-1—VERTICAL REINFORCING STEEL REQUIREMENTS FOR 6-INCH-THICK (153 mm) MASONRY WALLS<sup>1</sup> IN AREAS WHERE BASIC WIND SPEEDS ARE 80 MILES PER HOUR (129 km/h) OR GREATER<sup>2,3,4,5</sup>**  
 (Wood or Steel Roof and Floor Framing)



BOND BEAM. SEE FOOTNOTE 4 THIS TABLE AND TABLE A-21-E

VERTICAL BAR—STANDARD HOOK OVER BOND BEAM (alternate every other bar)

Criteria: Roof Live Load = 20 psf to 40 psf (0.96 kN/m<sup>2</sup> to 1.9 kN/m<sup>2</sup>);  
 Floor Live Load = 50 psf (2.4 kN/m<sup>2</sup>); enclosed building<sup>6</sup>

EXPOSURE	STORIES	UNSUPPORTED HEIGHT (feet)	80 MPH				90 MPH				100 MPH				110 MPH			
			× 1.61 for km/h															
			Span between Bearing Walls (feet)															
			× 304.8 for mm															
			8	16	24	32	8	16	24	32	8	16	24	32	8	16	24	32
			Size of Rebar and Spacing (Inches)															
			× 304.8 for mm															
			× 25.4 for mm															
B	One-story building	8	NR*								No. 4 80	No. 4 80	No. 4 80	No. 4 80	No. 4 64	No. 4 72	No. 4 88	
		10	No. 4 80	No. 4 88	No. 4 96	No. 4 96	No. 4 64	No. 4 64	No. 4 72	No. 4 80	No. 4 48	No. 4 48	No. 4 48	No. 4 56	No. 4 40	No. 4 40	No. 4 48	
		12	No. 4 48	No. 4 48	No. 4 56	No. 4 64	No. 4 40	No. 4 40	No. 4 48	No. 4 48	No. 5 48	No. 5 48	No. 5 56	No. 5 56	No. 5 40	No. 5 40	No. 5 40	
	Two-story building	Design required or use 8-inch or larger units for two-story condition.																
C	One-story building	8	No. 4 72	No. 4 72	No. 4 72	No. 4 96	No. 4 56	No. 4 56	No. 4 56	No. 4 56	No. 4 40	No. 4 40	No. 4 48	No. 4 48	No. 4 32	No. 4 32	No. 4 40	
		10	No. 4 40	No. 4 40	No. 4 40	No. 4 48	No. 4 32	No. 4 32	No. 4 32	No. 4 32	No. 5 40	No. 5 40	No. 5 40	No. 5 48	No. 5 32	No. 5 32	No. 5 40	
		12	No. 5 40	No. 5 48	No. 5 48	No. 5 48	No. 5 32	No. 5 32	No. 5 32	No. 5 40	Use 8-inch or larger units							
	Two-story building	Design required or use 8-inch or larger units for two-story condition.																
D	One-story building	8	No. 4 56	No. 4 56	No. 4 64	No. 4 80	No. 4 48	No. 4 48	No. 4 48	No. 4 48	No. 4 32	No. 4 40	No. 4 40	No. 4 40	No. 4 32	No. 4 32	No. 4 32	
		10	No. 4 32	No. 4 32	No. 4 32	No. 4 40	No. 5 40	No. 5 40	No. 5 48	No. 5 48	No. 5 48	No. 5 32	No. 5 32	No. 5 40	Use 8-inch or larger units			
		12	No. 5 32	No. 5 40	No. 5 40	No. 5 40	Use 8-inch or larger units											
	Two-story building	Design required or use 8-inch or larger units for two-story condition.																

\*NR — No vertical reinforcement required. However, see Table A-21-F for shear wall reinforcement.

<sup>1</sup>These values are for walls with running bond. For stack bond see Section 2112.8.3.

<sup>2</sup>The figure on top of the listed data is the bar size; the figure below it is the maximum spacing in inches (mm). Reinforcing bar strength shall be A 615 Grade 60. The vertical bars are centered in the middle of the wall.

- <sup>3</sup>Roof load is assumed to be concentrically loaded on the wall. For roofs which hang on ledgers, a design is required.
- <sup>4</sup>Minimum horizontal reinforcement shall be one No. 4 at the ledger and foundation. Also, see Table A-21-E for lintels and Table A-21-F for shear wall reinforcing where applicable.
- <sup>5</sup>Hook vertical bars over bond beam bars as shown. Extend bars into footing using lap splices where necessary.
- <sup>6</sup>Design required for open buildings of 6-inch-thick (153 mm) masonry.  
To use this table, check criteria by the following method:
- <sup>6.1</sup>Choose proper roof live load from Table 16-C or snow load criteria for the locality in which the building is located.
- <sup>6.2</sup>Check if building is enclosed or partially enclosed by the procedure in Chapter 16, Part II.
- <sup>6.3</sup>Choose proper floor load from Table 16-A. [For loads less than 50 pounds per square foot (psf) (2.4 kN/m<sup>2</sup>), use 50 psf (2.4 kN/m<sup>2</sup>), and for loads between 50 psf (2.4 kN/m<sup>2</sup>) and 100 psf (4.8 kN/m<sup>2</sup>), use 100 psf (4.8 kN/m<sup>2</sup>).]
- <sup>6.4</sup>Find proper wind speed and exposure for the site—see Figure 16-1, Chapter 16, Sections 1615 and 1616.
- <sup>6.5</sup>Within the proper vertical column, choose appropriate span-to-bearing wall and appropriate height and story.
- <sup>6.6</sup>Read proper size and spacing of reinforcement for the thickness of the wall mentioned in the title of the table. (Equivalent area of steel, taking spacing into account, may be substituted.)
- <sup>6.7</sup>For buildings in Seismic Zone 2 (see Figure 16-2 in Chapter 16), use minimum reinforcement in Figure A-21-2 if it is more restrictive than the table values.

**TABLE A-21-C-2—VERTICAL REINFORCING STEEL REQUIREMENTS FOR 8-INCH-THICK (203 mm) MASONRY WALLS<sup>1</sup> IN AREAS WHERE BASIC WIND SPEEDS ARE 80 MILES PER HOUR (129 km/h) OR GREATER<sup>2,3,4,5</sup>**  
 (Wood or Steel Roof and Floor Framing)



BOND BEAM. SEE FOOTNOTE 4 THIS TABLE AND TABLE A-21-E

VERTICAL BAR—STANDARD HOOK OVER BOND BEAM (alternate every other bar)

Criteria: Roof Live Load = 20 psf to 40 psf (0.96 kN/m<sup>2</sup> to 1.9 kN/m<sup>2</sup>);  
 Floor Live Load = 50 psf (2.4 kN/m<sup>2</sup>); enclosed building

EXPOSURE	STORIES	UNSUPPORTED HEIGHT (feet) × 304.8 for mm	80 MPH				90 MPH				100 MPH				110 MPH													
			× 1.61 for km/h																									
			Span between Bearing Walls (feet)																									
			× 304.8 for mm																									
			Size of Rebar and Spacing (Inches)																									
× 25.4 for mm																												
B	One-story building or top story of two-story building	8	NR*												No. 3 56	No. 3 56	No. 3 64	No. 3 64										
		10	NR*												No. 4 80	No. 4 80	No. 4 88	No. 4 88	No. 4 64	No. 4 64	No. 4 40	No. 4 40	No. 4 64	No. 4 64	No. 4 48	No. 4 48	No. 4 56	No. 4 56
		12	No. 4 64	No. 4 72	No. 4 72	No. 4 72	No. 4 56	No. 4 56	No. 4 56	No. 4 56	No. 4 40	No. 4 40	No. 4 64	No. 4 64	No. 4 56	No. 4 56	No. 4 56	No. 4 56	No. 4 56	No. 4 56	No. 4 56							
	First story of a two-story building	8	No. 3 96	No. 3 96	No. 3 96	No. 3 96	No. 3 96	No. 3 96	No. 3 96	No. 3 96	No. 3 96	No. 3 88	No. 3 80	No. 3 72	No. 3 72	No. 3 72	No. 3 72	No. 3 64	No. 3 64	No. 3 64	No. 3 64							
		10	No. 3 88	No. 3 80	No. 3 72	No. 3 64	No. 3 64	No. 3 64	No. 3 56	No. 3 56	No. 4 72	No. 4 72	No. 4 64	No. 4 64	No. 4 56	No. 4 56	No. 4 56	No. 4 56	No. 4 56	No. 4 56	No. 4 56							
		12	No. 4 80	No. 4 72	No. 4 64	No. 4 64	No. 4 64	No. 4 56	No. 4 56	No. 4 48	No. 4 48	No. 4 48	No. 4 64	No. 4 64	No. 4 56	No. 4 56	No. 4 56	No. 4 56	No. 4 56	No. 4 56	No. 4 56							
C	One-story building or top story of two-story building	8	NR*												No. 3 48	No. 3 48	No. 3 48	No. 3 56	No. 4 64	No. 4 64	No. 4 72	No. 4 72	No. 4 48	No. 4 56	No. 4 56	No. 4 56	No. 4 56	
		10	No. 4 56	No. 4 56	No. 4 64	No. 4 64	No. 4 48	No. 4 48	No. 4 48	No. 4 48	No. 4 56	No. 4 56	No. 4 56	No. 4 56	No. 4 56	No. 4 56	No. 4 56	No. 4 56	No. 4 56	No. 4 56	No. 4 56	No. 4 56	No. 4 56	No. 4 56				
		12	No. 5 56	No. 5 64	No. 5 64	No. 5 64	No. 5 48	No. 5 48	No. 5 48	No. 5 48	No. 5 56	No. 5 56	No. 5 56	No. 5 56	No. 5 56	No. 5 56	No. 5 56	No. 5 56	No. 5 56	No. 5 56	No. 5 56	No. 5 56	No. 5 56	No. 5 56	No. 5 56			
	First story of a two-story building	8	No. 3 80	No. 3 80	No. 3 56	No. 3 72	No. 3 56	No. 3 56	No. 3 56	No. 3 56	No. 4 72	No. 4 72	No. 4 72	No. 4 64	No. 4 56	No. 4 56	No. 4 56	No. 4 56	No. 4 56	No. 4 56	No. 4 56							
		10	No. 4 72	No. 4 64	No. 4 64	No. 4 56	No. 4 56	No. 4 48	No. 4 48	No. 4 48	No. 4 64	No. 4 56	No. 4 56	No. 4 56	No. 4 56	No. 4 56	No. 4 56	No. 4 56	No. 4 56	No. 4 56	No. 4 56							
		12	No. 5 64	No. 5 64	No. 5 56	No. 5 56	No. 5 48	No. 5 48	No. 5 48	No. 5 48	No. 5 56	No. 5 56	No. 5 56	No. 5 56	No. 5 56	No. 5 56	No. 5 56	No. 5 56	No. 5 56	No. 5 56	No. 5 56							
D	One-story building or top story of two-story building	8	No. 3 48	No. 3 48	No. 3 56	No. 3 56	No. 4 64	No. 4 72	No. 4 72	No. 4 80	No. 4 56	No. 4 56	No. 4 56	No. 4 56	No. 4 56	No. 4 56	No. 4 56	No. 4 56	No. 4 56	No. 4 56								
		10	No. 4 48	No. 4 48	No. 4 48	No. 4 56	No. 5 56	No. 5 64	No. 5 64	No. 5 64	No. 5 48	No. 5 48	No. 5 48	No. 5 48	No. 5 48	No. 5 48	No. 5 48	No. 5 48	No. 5 48	No. 5 48								
		12	No. 5 48	No. 5 48	No. 5 56	No. 5 56	No. 6 56	No. 6 56	No. 6 56	No. 6 56	No. 6 48	No. 6 48	No. 6 48	No. 6 48	No. 6 48	No. 6 48	No. 6 48	No. 6 48	No. 6 48	No. 6 48								

D cont.	First story of a two-story building	8	No. 3 64	No. 3 64	No. 3 64	No. 3 56	No. 4 80	No. 4 80	No. 4 72	No. 4 72	No. 4 64	No. 4 56	No. 4 56	No. 4 56	No. 4 48	No. 4 48	No. 4 48	No. 4 48	
		10	No. 4 56	No. 4 56	No. 4 56	No. 4 48	No. 4 48	No. 5 64	No. 5 64	No. 5 56	No. 5 48	No. 5 48	No. 5 48	No. 5 48	No. 5 40	No. 5 40	No. 5 40	No. 5 40	No. 5 32
		12	No. 5 56	No. 5 56	No. 5 48	No. 5 48	No. 6 56	No. 6 56	No. 6 56	No. 6 48	No. 6 48	No. 6 48	No. 6 48	No. 6 40	No. 6 40	No. 6 40	No. 6 40	No. 6 32	No. 6 32

\*NR — No vertical reinforcement required. However, see Table A-21-F for shear wall reinforcement.

<sup>1</sup>These values are for walls with running bond. For stack bond see Section 2112.8.3.

<sup>2</sup>The figure on top of the listed data is the bar size; the figure below it is the maximum spacing in inches (mm). Reinforcing bar strength shall be A 615 Grade 60.

<sup>3</sup>Roof load is assumed to be concentrically loaded on the wall. For roofs which hang on ledgers, a design is required.

<sup>4</sup>Minimum horizontal reinforcement shall be one No. 4 at the ledger and foundation. Also, see Table A-21-E for lintels and Table A-21-F for shear wall reinforcing where applicable.

<sup>5</sup>Hook vertical bars over bond beam as shown. Extend bars into footing using lap splices where necessary. Where second-story bar spacing does not match those on the first story, hook bars around floor bond beam also.

To use this table, check criteria by the following method:

<sup>5.1</sup>Choose proper roof live load from Table 16-C or snow load criteria for the locality in which the building is located.

<sup>5.2</sup>Check if building is enclosed or partially enclosed by the procedure in Chapter 16, Part II.

<sup>5.3</sup>Choose proper floor load from Table 16-A. [For loads less than 50 psf (2.4 kN/m<sup>2</sup>), use 50 psf (2.4 kN/m<sup>2</sup>), and for loads between 50 psf (2.4 kN/m<sup>2</sup>) and 100 psf (4.8 kN/m<sup>2</sup>), use 100 psf (4.8 kN/m<sup>2</sup>).]

<sup>5.4</sup>Find proper wind speed and exposure for the site—see Figure 16-1, Chapter 16, Sections 1615 and 1616.

<sup>5.5</sup>Within the proper vertical column, choose appropriate span-to-bearing wall and appropriate height and story.

<sup>5.6</sup>Read proper size and spacing of reinforcement for the thickness of the wall mentioned in the title of the table. (Equivalent area of steel, taking spacing into account, may be substituted.)

<sup>5.7</sup>For buildings in Seismic Zone 2 (see Figure 16-2 in Chapter 16), use minimum reinforcement in Figure A-21-2 if it is more restrictive than the table values.

**TABLE A-21-C-3—VERTICAL REINFORCING STEEL REQUIREMENTS FOR 8-INCH-THICK (203 mm) MASONRY WALLS<sup>1</sup> IN AREAS WHERE BASIC WIND SPEEDS ARE 80 MILES PER HOUR (129 km/h) OR GREATER<sup>2,3,4,5</sup>**  
 (Wood or Steel Roof and Floor Framing)



BOND BEAM. SEE FOOTNOTE 4 THIS TABLE AND TABLE A-21-E

VERTICAL BAR—STANDARD HOOK OVER BOND BEAM (alternate every other bar)

Criteria: Roof Live Load = 20 psf to 40 psf (0.96 kN/m<sup>2</sup> to 1.9 kN/m<sup>2</sup>);  
 Floor Live Load = 100 psf (4.8 kN/m<sup>2</sup>); enclosed building

EXPOSURE	STORIES	UNSUPPORTED HEIGHT (feet)	80 MPH				90 MPH				100 MPH				110 MPH				
			× 1.61 for km/h																
			Span between Bearing Walls (feet)																
			× 304.8 for mm																
			8	16	24	32	8	16	24	32	8	16	24	32	8	16	24	32	
Size of Rebar and Spacing (inches)																			
		× 304.8 for mm		× 25.4 for mm															
B	One-story building or top story of two-story building	8	NR*												No. 3 56	No. 3 56	No. 3 64	No. 3 64	
		10	NR*				No. 4 64	No. 4 64	No. 4 64	No. 4 72	No. 4 64	No. 4 64	No. 4 64	No. 4 72	No. 4 48	No. 4 48	No. 4 56	No. 4 56	
		12	No. 4 64	No. 4 72	No. 4 72	No. 4 72	No. 4 56	No. 4 56	No. 4 56	No. 4 56	No. 4 40	No. 4 40	No. 4 40	No. 4 40	No. 5 56	No. 5 56	No. 5 56	No. 5 56	
	First story of a two-story building	8	No. 3 96	No. 3 96	No. 3 80	No. 3 64	No. 3 96	No. 3 88	No. 3 72	No. 3 56	No. 3 80	No. 3 64	No. 3 56	No. 3 64	No. 3 56	No. 3 56	No. 3 48	No. 4 64	
		10	No. 3 72	No. 3 64	No. 3 56	No. 3 48	No. 3 56	No. 3 48	No. 4 64	No. 4 56	No. 4 72	No. 4 64	No. 4 56	No. 4 48	No. 4 56	No. 4 48	No. 4 48	No. 5 56	
		12	No. 4 72	No. 4 64	No. 4 56	No. 4 48	No. 4 56	No. 4 48	No. 4 48	No. 4 40	No. 4 48	No. 4 40	No. 4 48	No. 5 48	No. 5 56	No. 5 48	No. 5 48	No. 5 40	
C	One-story building or top story of two-story building	8	NR*				No. 3 48	No. 3 48	No. 3 48	No. 3 56	No. 4 64	No. 4 64	No. 4 72	No. 4 72	No. 4 48	No. 4 56	No. 4 56	No. 4 56	
		10	No. 4 56	No. 4 56	No. 4 64	No. 4 64	No. 4 48	No. 4 48	No. 4 48	No. 4 48	No. 5 56	No. 5 56	No. 5 56	No. 5 56	No. 5 48	No. 5 48	No. 5 48	No. 5 48	
		12	No. 4 40	No. 5 64	No. 5 64	No. 5 64	No. 5 48	No. 5 48	No. 5 48	No. 5 48	No. 5 40	No. 5 56	No. 5 56	No. 6 56	No. 6 56	No. 6 56	No. 6 40	No. 6 40	No. 5 32
	First story of a two-story building	8	No. 3 72	No. 3 64	No. 3 56	No. 3 48	No. 3 56	No. 3 48	No. 4 64	No. 4 56	No. 4 72	No. 4 64	No. 4 56	No. 4 48	No. 4 56	No. 4 48	No. 4 48	No. 5 56	
		10	No. 4 64	No. 4 56	No. 4 48	No. 4 48	No. 4 48	No. 4 48	No. 5 56	No. 5 56	No. 5 56	No. 5 56	No. 5 48	No. 5 48	No. 5 48	No. 5 48	No. 5 40	No. 5 40	
		12	No. 4 40	No. 5 56	No. 5 48	No. 5 48	No. 5 48	No. 5 40	No. 5 40	No. 5 48	No. 5 40	No. 5 48	No. 6 48	No. 6 40	No. 6 40	No. 6 40	No. 6 40	No. 6 32	
D	One-story building or top story of two-story building	8	No. 3 48	No. 3 48	No. 3 56	No. 3 56	No. 3 64	No. 4 72	No. 4 72	No. 4 80	No. 4 56	No. 4 56	No. 4 56	No. 4 56	No. 4 40	No. 4 48	No. 4 48	No. 4 48	
		10	No. 4 48	No. 4 48	No. 4 48	No. 4 56	No. 5 56	No. 5 64	No. 5 64	No. 5 64	No. 5 48	No. 5 48	No. 5 48	No. 5 48	No. 5 40	No. 5 40	No. 5 40	No. 5 40	
		12	No. 5 48	No. 5 48	No. 5 56	No. 5 56	No. 5 40	No. 5 40	No. 6 56	No. 6 56	No. 6 48	No. 6 48	No. 6 48	No. 5 32	No. 6 40	No. 6 40	No. 6 40	No. 6 40	

D cont.	First story of a two-story building	8	No. 3 56	No. 3 56	No. 3 48	No. 4 64	No. 3 48	No. 4 64	No. 4 56	No. 4 56	No. 4 56	No. 4 56	No. 4 48	No. 5 64	No. 4 48	No. 5 64	No. 5 56	No. 5 56	
		10	No. 4 56	No. 4 48	No. 4 48	No. 5 56	No. 5 64	No. 5 56	No. 5 48	No. 5 48	No. 5 48	No. 5 48	No. 5 40	No. 5 40	No. 5 40	No. 5 40	No. 5 40	No. 6 48	No. 6 48
		12	No. 5 48	No. 5 48	No. 5 40	No. 5 40	No. 5 40	No. 5 40	No. 6 48	No. 6 40	No. 6 48	No. 6 40	No. 6 40	No. 6 40	No. 6 32	No. 6 32	No. 6 32	No. 6 32	No. 6 24

\*NR — No vertical reinforcement required. However, see Table A-21-F for shear wall reinforcement.

<sup>1</sup>These values are for walls with running bond. For stack bond see Section 2112.8.3.

<sup>2</sup>The figure on top of the listed data is the bar size; the figure below it is the maximum spacing in inches (mm). Reinforcing bar strength shall be A 615 Grade 60.

<sup>3</sup>Roof load is assumed to be concentrically loaded on the wall. For roofs which hang on ledgers, a design is required.

<sup>4</sup>Minimum horizontal reinforcement shall be one No. 4 at the ledger and foundation. Also, see Table A-21-E for lintels and Table A-21-F for shear wall reinforcing where applicable.

<sup>5</sup>Hook vertical bars over bond beam as shown. Extend bars into footing using lap splices where necessary. Where second-story bar spacing does not match those on the first story, hook bars around floor bond beam also.

To use this table, check criteria by the following method:

<sup>5.1</sup> Choose proper roof live load from Table 16-C or snow load criteria for the locality in which the building is located.

<sup>5.2</sup> Check if building is enclosed or partially enclosed by the procedure in Chapter 16, Part II.

<sup>5.3</sup> Choose proper floor load from Table 16-A. [For loads less than 50 psf (2.4 kN/m<sup>2</sup>), use 50 psf (2.4 kN/m<sup>2</sup>), and for loads between 50 psf (2.4 kN/m<sup>2</sup>) and 100 psf (4.8 kN/m<sup>2</sup>), use 100 psf (4.8 kN/m<sup>2</sup>).]

<sup>5.4</sup> Find proper wind speed and exposure for the site—see Figure 16-1, Chapter 16, Sections 1615 and 1616.

<sup>5.5</sup> Within the proper vertical column, choose appropriate span-to-bearing wall and appropriate height and story.

<sup>5.6</sup> Read proper size and spacing of reinforcement for the thickness of the wall mentioned in the title of the table. (Equivalent area of steel, taking spacing into account, may be substituted.)

<sup>5.7</sup> For buildings in Seismic Zone 2 (see Figure 16-2 in Chapter 16), use minimum reinforcement in Figure A-21-2 if it is more restrictive than the table values.

**TABLE A-21-C-4—VERTICAL REINFORCING STEEL REQUIREMENTS FOR 8-INCH-THICK (203 mm) MASONRY WALLS<sup>1</sup> IN AREAS WHERE BASIC WIND SPEEDS ARE 80 MILES PER HOUR (129 km/h) OR GREATER<sup>2,3,4,5</sup>**  
 (Wood or Steel Roof and Floor Framing)



BOND BEAM. SEE FOOTNOTE 4 THIS TABLE AND TABLE A-21-E

VERTICAL BAR—STANDARD HOOK OVER BOND BEAM (alternate every other bar)

Criteria: Roof Live Load = 20 psf to 40 psf (0.96 kN/m<sup>2</sup> to 1.9 kN/m<sup>2</sup>);  
 Floor Live Load = 50 psf (2.4 kN/m<sup>2</sup>); partially enclosed building

EXPOSURE	STORIES	UNSUPPORTED HEIGHT (feet) × 304.8 for mm	80 MPH				90 MPH				100 MPH				110 MPH			
			× 1.61 for km/h															
			Span between Bearing Walls (feet)															
			× 304.8 for mm															
			8	16	24	32	8	16	24	32	8	16	24	32	8	16	24	32
			Size of Rebar and Spacing (inches) × 25.4 for mm															
B	One-story building or top story of two-story building	8	No. 4 96	No. 4 96	No. 3 80	No. 3 88	No. 3 56	No. 3 56	No. 3 64	No. 3 64	No. 3 40	No. 3 48	No. 3 48	No. 3 48	No. 4 64	No. 4 64	No. 4 64	No. 4 72
		10	No. 4 64	No. 4 64	No. 4 72	No. 4 72	No. 4 48	No. 4 56	No. 4 56	No. 4 56	No. 4 40	No. 4 40	No. 4 40	No. 4 40	No. 5 48	No. 5 56	No. 5 56	No. 5 56
		12	No. 4 40	No. 4 48	No. 4 48	No. 4 48	No. 5 48	No. 5 56	No. 5 56	No. 5 56	No. 5 40	No. 5 40	No. 5 40	No. 5 40	No. 6 48	No. 6 48	No. 6 48	No. 6 48
	First story of a two-story building	8	No. 3 96	No. 3 96	No. 3 88	No. 3 80	No. 3 72	No. 3 72	No. 3 64	No. 3 64	No. 3 48	No. 3 48	No. 3 48	No. 3 48	No. 4 64	No. 4 64	No. 4 64	No. 4 64
		10	No. 3 48	No. 3 48	No. 3 48	No. 3 48	No. 4 64	No. 4 56	No. 4 56	No. 4 56	No. 4 48	No. 4 48	No. 4 48	No. 4 40	No. 5 56	No. 5 56	No. 5 56	No. 5 48
		12	No. 4 48	No. 4 48	No. 4 48	No. 4 40	No. 4 40	No. 5 56	No. 5 56	No. 5 48	No. 5 48	No. 5 40	No. 5 40	No. 5 40	No. 6 48	No. 6 48	No. 6 48	No. 6 48
C	One-story building or top story of two-story building	8	No. 3 40	No. 3 40	No. 3 40	No. 3 40	No. 4 56	No. 4 56	No. 4 56	No. 4 56	No. 4 40	No. 4 40	No. 4 40	No. 4 48	No. 5 56	No. 5 56	No. 5 56	No. 5 56
		10	No. 4 40	No. 4 40	No. 4 40	No. 4 40	No. 5 48	No. 5 48	No. 5 48	No. 5 48	No. 5 32	No. 5 32	No. 5 40	No. 5 40	No. 6 40	No. 6 40	No. 6 40	No. 6 40
		12	No. 5 40	No. 5 40	No. 5 40	No. 5 40	No. 6 40	No. 6 48	No. 6 48	No. 6 48	No. 6 32	No. 6 32	No. 6 32	No. 6 32	Use 10-inch or larger units			
	First story of a two-story building	8	No. 3 48	No. 3 48	No. 3 48	No. 3 48	No. 4 56	No. 4 56	No. 4 56	No. 4 56	No. 4 48	No. 4 48	No. 4 40	No. 4 40	No. 5 56	No. 5 56	No. 5 56	No. 5 48
		10	No. 4 40	No. 4 40	No. 4 40	No. 4 40	No. 5 48	No. 5 48	No. 5 48	No. 5 48	No. 5 40	No. 5 40	No. 5 40	No. 6 48	No. 6 48	No. 6 40	No. 6 40	No. 6 40
		12	No. 5 40	No. 5 40	No. 5 40	No. 6 48	No. 6 48	No. 6 48	No. 6 40	No. 6 40	No. 6 32	No. 6 32	No. 6 32	No. 6 32	Use 10-inch or larger units			
D	One-story building or top story of two-story building	8	No. 4 56	No. 4 56	No. 4 56	No. 4 64	No. 4 40	No. 4 48	No. 4 48	No. 4 48	No. 5 56	No. 5 56	No. 5 56	No. 5 56	No. 5 48	No. 5 48	No. 5 48	No. 5 48
		10	No. 5 48	No. 5 48	No. 5 48	No. 5 56	No. 5 40	No. 5 40	No. 5 40	No. 5 40	No. 6 56	No. 6 48	No. 6 48	No. 6 48	No. 6 32	No. 6 32	No. 6 40	No. 6 40
		12	No. 6 48	No. 6 48	No. 6 48	No. 6 48	No. 6 40	No. 6 40	No. 6 40	No. 6 40	No. 6 24	No. 6 32	No. 6 32	No. 6 32	Use 10-inch or larger units			

D cont.	First story of a two-story building	8	No. 4 64	No. 4 64	No. 4 64	No. 4 56	No. 4 48	No. 4 48	No. 4 48	No. 4 48	No. 4 40	No. 4 40	No. 5 56	No. 5 56	No. 5 48	No. 5 48	No. 5 48	No. 5 40	
		10	No. 5 56	No. 5 56	No. 5 48	No. 5 48	No. 5 40	No. 5 40	No. 5 40	No. 5 40	No. 6 48	No. 6 48	No. 6 48	No. 6 40	No. 6 40	No. 6 40	No. 6 40	No. 6 32	No. 6 32
		12	No. 6 48	No. 6 48	No. 6 48	No. 6 48	No. 6 40	No. 6 40	Use 10-inch or larger units										

\*NR — No vertical reinforcement required. However, see Table A-21-F for shear wall reinforcement.

<sup>1</sup>These values are for walls with running bond. For stack bond see Section 2112.8.3.

<sup>2</sup>The figure on top of the listed data is the bar size; the figure below it is the maximum spacing in inches (mm). Reinforcing bar strength shall be A 615 Grade 60.

<sup>3</sup>Roof load is assumed to be concentrically loaded on the wall. For roofs which hang on ledgers, a design is required.

<sup>4</sup>Minimum horizontal reinforcement shall be one No. 4 at the ledger and foundation. Also, see Table A-21-E for lintels and Table A-21-F for shear wall reinforcing where applicable.

<sup>5</sup>Hook vertical bars over bond beam as shown. Extend bars into footing using lap splices where necessary.

To use this table, check criteria by the following method:

<sup>5.1</sup> Choose proper roof live load from Table 16-C or snow load criteria for the locality in which the building is located.

<sup>5.2</sup> Check if building is enclosed or partially enclosed by the procedure in Chapter 16, Part II.

<sup>5.3</sup> Choose proper floor load from Table 16-A. [For loads less than 50 psf (2.4 kN/m<sup>2</sup>), use 50 psf (2.4 kN/m<sup>2</sup>), and for loads between 50 psf (2.4 kN/m<sup>2</sup>) and 100 psf (4.8 kN/m<sup>2</sup>), use 100 psf (4.8 kN/m<sup>2</sup>).]

<sup>5.4</sup> Find proper wind speed and exposure for the site—see Figure 16-1, Chapter 16, Sections 1615 and 1616.

<sup>5.5</sup> Within the proper vertical column, choose appropriate span-to-bearing wall and appropriate height and story.

<sup>5.6</sup> Read proper size and spacing of reinforcement for the thickness of the wall mentioned in the title of the table. (Equivalent area of steel, taking spacing into account, may be substituted.)

<sup>5.7</sup> For buildings in Seismic Zone 2 (see Figure 16-2 in Chapter 16), use minimum reinforcement in Figure A-21-2 if it is more restrictive than the table values.

**TABLE A-21-C-5—VERTICAL REINFORCING STEEL REQUIREMENTS FOR 8-INCH-THICK (203 mm) MASONRY WALLS<sup>1</sup> IN AREAS WHERE BASIC WIND SPEEDS ARE 80 MILES PER HOUR (129 km/h) OR GREATER<sup>2,3,4,5</sup>**  
 (Wood or Steel Roof and Floor Framing)

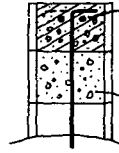

BOND BEAM. SEE FOOTNOTE 4 THIS TABLE AND TABLE A-21-E

VERTICAL BAR—STANDARD HOOK OVER BOND BEAM (alternate every other bar)

Criteria: Roof Live Load = 20 psf to 40 psf (0.96 kN/m<sup>2</sup> to 1.9 kN/m<sup>2</sup>);  
 Floor Live Load = 100 psf (4.8 kN/m<sup>2</sup>); partially enclosed building

EXPOSURE	STORIES	UNSUPPORTED HEIGHT (feet)	80 MPH				90 MPH				100 MPH				110 MPH			
			× 1.61 for km/h															
			Span between Bearing Walls (feet)															
			× 304.8 for mm															
			8	16	24	32	8	16	24	32	8	16	24	32	8	16	24	32
Size of Rebar and Spacing (inches)																		
× 304.8 for mm																		
× 25.4 for mm																		
B	One-story building or top story of two-story building	8	No. 3 72	No. 4 96	No. 3 80	No. 3 88	No. 3 56	No. 3 56	No. 3 64	No. 3 64	No. 4 80	No. 4 80	No. 4 80	No. 4 88	No. 4 64	No. 4 64	No. 4 72	
		10	No. 4 64	No. 4 64	No. 4 72	No. 4 72	No. 4 48	No. 4 56	No. 4 56	No. 4 56	No. 4 40	No. 4 40	No. 4 40	No. 4 40	No. 5 48	No. 5 56	No. 5 56	No. 5 56
		12	No. 4 40	No. 4 48	No. 4 48	No. 4 48	No. 5 56	No. 5 56	No. 5 56	No. 5 56	No. 5 40	No. 5 40	No. 5 40	No. 5 40	No. 6 48	No. 6 48	No. 6 48	No. 6 48
	First story of a two-story building	8	No. 3 88	No. 3 96	No. 3 56	No. 4 72	No. 3 64	No. 3 56	No. 3 64	No. 4 80	No. 4 80	No. 4 72	No. 4 64	No. 4 56	No. 4 56	No. 4 48	No. 4 48	
		10	No. 4 72	No. 4 64	No. 4 56	No. 4 48	No. 4 56	No. 4 48	No. 4 48	No. 4 40	No. 4 40	No. 5 56	No. 5 48	No. 5 56	No. 5 48	No. 5 48	No. 5 40	
		12	No. 4 48	No. 4 40	No. 4 40	No. 5 48	No. 5 56	No. 5 48	No. 5 48	No. 5 40	No. 5 40	No. 5 40	No. 6 48	No. 6 48	No. 6 48	No. 6 40	No. 6 40	
C	One-story building or top story of two-story building	8	No. 4 64	No. 4 64	No. 4 72	No. 4 72	No. 4 56	No. 4 56	No. 4 56	No. 4 40	No. 4 40	No. 4 40	No. 4 48	No. 5 56	No. 5 56	No. 5 56	No. 5 56	
		10	No. 5 56	No. 5 56	No. 4 40	No. 4 40	No. 5 48	No. 5 48	No. 5 48	No. 5 48	No. 5 32	No. 6 56	No. 6 56	No. 5 40	No. 6 40	No. 6 40	No. 6 40	
		12	No. 5 40	No. 5 40	No. 5 40	No. 5 40	No. 6 40	No. 6 48	No. 6 48	No. 6 48	No. 6 32	No. 6 32	No. 6 32	Use 10-inch or larger units				
	First story of a two-story building	8	No. 4 72	No. 4 64	No. 4 56	No. 4 48	No. 4 56	No. 4 48	No. 4 48	No. 4 40	No. 4 40	No. 4 40	No. 4 48	No. 5 56	No. 5 48	No. 5 48	No. 5 40	
		10	No. 5 64	No. 5 56	No. 5 48	No. 5 48	No. 5 48	No. 5 48	No. 5 40	No. 5 40	No. 5 40	No. 6 48	No. 6 40	No. 6 40	No. 6 40	No. 6 40	No. 6 32	
		12	No. 5 40	No. 6 48	No. 6 48	No. 6 40	No. 6 40	No. 6 40	No. 6 32	No. 6 32	No. 6 32	Use 10-inch or larger units						
D	One-story building or top story of two-story building	8	No. 4 56	No. 4 56	No. 4 56	No. 4 64	No. 4 40	No. 5 72	No. 5 72	No. 5 72	No. 5 56	No. 5 56	No. 5 56	No. 5 56	No. 5 48	No. 5 48	No. 5 48	
		10	No. 5 48	No. 5 48	No. 5 48	No. 5 56	No. 5 40	No. 5 40	No. 5 40	No. 5 40	No. 6 56	No. 6 48	No. 6 48	No. 6 32	No. 6 32	No. 6 40	No. 6 40	
		12	No. 6 48	No. 6 48	No. 6 48	No. 6 48	No. 6 40	No. 6 40	No. 6 40	No. 6 40	No. 6 24	No. 6 32	No. 6 32	Use 10-inch or larger units				

D cont.	First story of a two-story building	8	No. 4 64	No. 4 56	No. 4 48	No. 4 48	No. 4 48	No. 5 64	No. 5 56	No. 5 56	No. 5 56	No. 5 48	No. 5 48	No. 5 48	No. 5 48	No. 5 40	No. 5 40	No. 5 40	
		10	No. 5 56	No. 5 48	No. 5 48	No. 5 40	No. 5 40	No. 5 40	No. 6 48	No. 6 48	No. 6 48	No. 6 48	No. 6 40	No. 6 40	No. 6 40	No. 6 32	No. 6 32	No. 6 32	No. 6 32
		12	No. 6 48	No. 6 48	No. 6 40	No. 6 40	No. 6 40	No. 6 40	No. 6 32	No. 6 32	No. 6 32	Use 10-inch or larger units							

\*NR — No vertical reinforcement required. However, see Table A-21-F for shear wall reinforcement.

<sup>1</sup>These values are for walls with running bond. For stack bond see Section 2112.8.3.

<sup>2</sup>The figure on top of the listed data is the bar size; the figure below it is the maximum spacing in inches (mm). Reinforcing bar strength shall be A 615 Grade 60.

<sup>3</sup>Roof load is assumed to be concentrically loaded on the wall. For roofs which hang on ledgers, a design is required.

<sup>4</sup>Minimum horizontal reinforcement shall be one No. 4 at the ledger and foundation. Also, see Table A-21-E for lintels and Table A-21-F for shear wall reinforcing where applicable.

<sup>5</sup>Hook vertical bars over bond beam as shown. Extend bars into footing using lap splices where necessary.

To use this table, check criteria by the following method:

<sup>5.1</sup>Choose proper roof live load from Table 16-C or snow load criteria for the locality in which the building is located.

<sup>5.2</sup>Check if building is enclosed or partially enclosed by the procedure in Chapter 16, Part II.

<sup>5.3</sup>Choose proper floor load from Table 16-A. [For loads less than 50 psf (2.4 kN/m<sup>2</sup>), use 50 psf (2.4 kN/m<sup>2</sup>), and for loads between 50 psf (2.4 kN/m<sup>2</sup>) and 100 psf (4.8 kN/m<sup>2</sup>), use 100 psf (4.8 kN/m<sup>2</sup>).]

<sup>5.4</sup>Find proper wind speed and exposure for the site—see Figure 16-1, Chapter 16, Sections 1615 and 1616.

<sup>5.5</sup>Within the proper vertical column, choose appropriate span-to-bearing wall and appropriate height and story.

<sup>5.6</sup>Read proper size and spacing of reinforcement for the thickness of the wall mentioned in the title of the table. (Equivalent area of steel, taking spacing into account, may be substituted.)

<sup>5.7</sup>For buildings in Seismic Zone 2 (see Figure 16-2 in Chapter 16), use minimum reinforcement in Figure A-21-2 if it is more restrictive than the table values.

**TABLE A-21-D—ANCHORAGE OF WOOD MEMBERS TO EXTERIOR WALLS FOR VERTICAL AND UPLIFT FORCES**  
 [In areas where basic wind speeds are 80 miles per hour (129 km/h) or greater]

See Figure A-21-7 for details

**Part I—Anchor bolt size and spacing [in inches (in mm)]<sup>1,2,3</sup> on wood ledgers carrying vertical loads from roofs and floors<sup>4,5</sup>  
 Douglas fir-larch, California redwood (close grain) and southern pine<sup>6,7</sup>**

TYPE OF LOADING	LIVE LOAD <sup>8,9</sup> psf  x 0.0479 for kN/m <sup>2</sup> )	2-INCH (51 mm x) x LEDGER				3-INCH (76 mm x) x LEDGER				4-INCH (102 mm x) x LEDGER			
		Span between Bearing Walls (feet)											
		x 304.8 for mm											
		8	16	24	32	8	16	24	32	8	16	24	32
Roof	20	1/2 32	(2)1/2 16	5/8 16	7/8 16	1/2 32	1/2 16	(2)1/2 32	7/8 16	—	5/8 32	7/8 32	(2)5/8 32
	30	(2)1/2 32	1/2 16	3/4 16	7/8 16	1/2 16	(2)7/8 32	7/8 16	7/8 16	—	(2)1/2 32	5/8 16	3/4 16
	40	1/2 16	5/8 16	3/4 8	—	5/8 16	(2)5/8 32	7/8 16	1 16	5/8 32	5/8 16	3/4 16	7/8 16
Floor <sup>10</sup>	50	1/2 16	1 12	—	—	5/8 24	3/4 32	3/4 12	1 1/4 12	5/8 24	7/8 24	7/8 16	7/8 12
	100	1 16	(2)3/4 12	—	—	5/8 16	1 12	(2)3/4 12	(2)1 12	7/8 16	3/4 12	1 12	(2)3/4 12

<sup>1</sup>Closer spacing may be used.

<sup>2</sup>Use two bolts, one above the other, at splices and locate them away from the splice end by 3 1/2 inches (89 mm) for 1/2-inch (13 mm) diameter, 4 1/2 inches (114.3 mm) for 5/8-inch (15.9 mm) diameter, 5 1/4 inches (133 mm) for 3/4-inch (19 mm) diameter, 6 1/4 inches (158 mm) for 7/8-inch (22.2 mm) diameter and 7 inches (178 mm) for 1-inch (25.4 mm) diameter.

<sup>3</sup>See Table A-21-F for lateral force requirements (when applicable).

<sup>4</sup>Tabulated values are based on short-term loading due to roof loads (25 percent) or snow loads (15 percent), whichever controls. No increase is allowed for floor loads.

<sup>5</sup>See details in Figure A-21-7 for location relative to other construction. Note that roofs are concentrically loaded.

<sup>6</sup>See Chapter 23, Division III, Table 23-III-G, for other species. Adjust spacing in direct proportion to the perpendicular-to-grain values for the applicable ledger and bolt sizes shown using the procedure described in Section 2310.2, second paragraph. No increase is allowed for special inspection.

<sup>7</sup>Values on top are bolt sizes and underneath are spacing. Multiple bolts are shown in parenthesis: example (2) = two.

<sup>8</sup>See Table 16-C or Appendix Chapter 16, Division I, for values.

<sup>9</sup>Joist spacing is limited to 30 inches (762 mm) on center maximum.

<sup>10</sup>Where two bolts are required they shall be staggered at half the spacing shown or be placed one above the other.

**Part II—Uplift anchors<sup>1</sup> for wood roof members [number of common nails in a 0.036 inch (0.91 mm) (No. 20 galvanized sheet gage) by 1<sup>1</sup>/<sub>8</sub>-inch (28.6 mm) tie strap embedded 5 inches (127 mm) into a masonry bond beam<sup>2</sup>]**

ENCLOSURE <sup>3</sup>	EXPOSURE <sup>4</sup>	80 MPH				90 MPH				100 MPH				110 MPH				
		x 1.61 for km/h																
		Span between Bearing Walls (feet) <sup>5</sup>																
		x 304.8 for mm																
		8	16	24	32	8	16	24	32	8	16	24	32	8	16	24	32	
Enclosed	B	NR	NR	NR	NR	NR	NR	NR	NR	NR	NR	NR	NR	NR	NR	NR	2-8d	2-8d
	C	NR	NR	NR	NR	NR	2-8d	3-8d	4-8d	2-8d	4-8d	5-10d	5-10d	2-10d	4-10d	3-10d	4-10d	4-10d
	D	NR	2-8d	3-8d	4-8d	2-8d	4-8d	4-10d	5-10d	3-8d	5-8d	5-10d	4-10d	3-10d	5-10d	4-10d	5-10d	5-10d
Open	B	NR	NR	NR	NR	NR	NR	2-8d	2-8d	NR	2-8d	4-8d	5-10d	2-8d	4-8d	5-8d	6-10d	6-10d
	C	2-8d	4-8d	5-8d	5-10d	3-8d	5-8d	3-10d	4-10d	3-10d	5-10d	5-10d	5-10d	5-8d	4-10d	5-10d	6-10d	6-10d
	D	2-8d	5-8d	5-10d	5-10d	4-8d	5-10d	4-10d	5-10d	5-8d	4-10d	6-10d	6-10d	4-8d	5-10d	6-10d	6-10d	6-10d

NR — No requirements; use Table 23-I-Q minimum.

<sup>1</sup>Tie straps are at 48 inches (1219 mm) on center unless otherwise stated. See Figure A-21-7 for illustration of tie straps.

<sup>2</sup>Bond beam to be at least 48 inches (1219 mm) deep nominal and shall be reinforced as shown in Table A-21-E for lintels, or Tables A-21-C-1 through A-21-C-5 for walls in general where they are more restrictive.

<sup>3</sup>See Chapter 21, Part II, for definitions.

<sup>4</sup>See Section 1613 for definitions.

<sup>5</sup>For flat roofs connected to interior walls, the span shall be one half the larger distance on either side of the wall.

**TABLE A-21-E—LINTEL REINFORCEMENT OVER EXTERIOR OPENINGS<sup>1,2</sup>—WOOD AND STEEL FRAMING<sup>3</sup>**  
**[Lintels larger than 12 feet 0 inch (3658 mm) shall be designed.]<sup>4</sup>**  
**8-INCH (203 mm) MASONRY UNITS<sup>5</sup>**

Part I—Roof Loads<sup>5</sup>

ANY WALL HEIGHT (feet)	SPAN TO BEARING WALLS (feet) <sup>9</sup>	SECOND STORY OF A TWO-STORY OR ONE-STORY BUILDINGS ROOF LIVE LOAD <sup>6,7,8</sup>					
		20-30 psf			40 psf		
		× 0.0479 for kN/m <sup>2</sup>					
		Width of Opening <sup>9</sup> (feet)					
		× 304.8 for mm					
		4	8	12	4	8	12
		Lintel depth (Inches) number and size of rebar					
× 304.8 for mm		× 25.4 for mm					
Any (up to 12')	8	8 1 No. 3	8 1 No. 3	16 1 No. 4 (B)	8 1 No. 3	8 1 No. 4	16 1 No. 4 (B)
	16	8 1 No. 3	8 1 No. 3	16 1 No. 4 (B)	8 1 No. 3	8 2 No. 4 (A)	16 2 No. 5 (B)
	24	8 1 No. 3	8 1 No. 4	16 1 No. 4 (B)	8 1 No. 3	16 1 No. 4 (B)	24 2 No. 5 (B)
	32	8 1 No. 3	16 1 No. 4 (B)	16 1 No. 5 (B)	8 1 No. 3	16 1 No. 5 (B)	24 2 No. 5 (C)

Part II—Floor and Roof Loads<sup>5</sup>

WALL HEIGHT	SPAN TO BEARING <sup>9,11</sup> WALLS (feet)	FIRST STORY OF TWO-STORY BUILDINGS FLOOR LIVE LOAD <sup>10</sup>					
		50 psf			100 psf		
		× 0.0479 for kN/m <sup>2</sup>					
		Width of Opening <sup>9</sup> (feet)					
		× 304.8 for mm					
		4	8	12	4	8	12
× 304.8 for mm		Lintel depth (inches) number and size of rebar					
		× 25.4 for mm					
Any (up to 12')	8	8 1 No. 3	8 1 No. 4	16 1 No. 4 (B)	8 1 No. 3	8 2 No. 4 (A)	16 2 No. 5 (B)
	16	8 1 No. 3	8 2 No. 4 (A)	16 2 No. 5 (B)	8 1 No. 3	16 1 No. 4 (B)	24 2 No. 4 (C)
	24	8 1 No. 3	16 1 No. 4 (B)	24 2 No. 5 (B)	8 1 No. 3 (A)	16 1 No. 5 (B)	24 3 No. 5 (C)
	32	8 1 No. 3	16 1 No. 5 (B)	24 2 No. 5 (C)	8 1 No. 4 (B)	24 2 No. 5 (C)	Design Required

<sup>1</sup>The values shown are number and size of A 615, 60 grade steel reinforcement bars: Example—2 No. 4 is two 1/2-inch-diameter (13 mm) deformed reinforcing bars. See also Figure A-21-D for continuous load path.

<sup>2</sup>Stirrup spacing requirements: A = No. 3 at 8 inches (203 mm) on center, B = No. 3 at 4 inches (102 mm) on center, C = No. 4 at 8 inches (203 mm) on center. None are required unless specifically mentioned in the table.

<sup>3</sup>Design required for lintels supporting precast planks.

<sup>4</sup>Lintels are 8-inch (203 mm) nominal depth where supporting roof loads only and 16-inch (406 mm) nominal depth where supporting floor and roofs unless otherwise stated. All lintels are solidly grouted.

<sup>5</sup>Wall weight is included.

<sup>6</sup>The stirrup size and spacing, where required, as indicated in parenthesis below the reinforcing bar requirements.

<sup>7</sup>All exposure categories are included for wind uplift on the lintel. See Footnote 4 of Tables A-21-C-1 through A-21-C-5 as a minimum bond beam. Table A-21-F may also control.

<sup>8</sup>Two No. 5 vertical bars minimum are required on each side of the lintel for 100 and 110 miles per hour (161 and 177 km/h), Exposure D. Bar to extend 25 inches (635 mm) beyond opening or hook over top bars.

<sup>9</sup>For spans between the figures shown, go to next higher span width.

<sup>10</sup>From Table 21-A. For other floor loads go to next higher value. Where required floor load exceeds 100 pounds per square foot (4.8 kN/m<sup>2</sup>), a design is required.

<sup>11</sup>When interior walls support floors from each side, these values may be used if the spans on each side are less than 16 feet 0 inch (4877 mm) each. Enter the table with the total of both span widths.

**TABLE A-21-F—MASONRY SHEAR WALL<sup>1,2,3</sup> AND DIAPHRAGM REQUIREMENTS IN HIGH-WIND AREAS<sup>4</sup>**

**Part I—Minimum wall length and horizontal bar reinforcement required for exterior shear walls and cross walls<sup>5</sup> (all wall heights). [Design criteria: 20 psf to 40 psf (0.96 kN/m<sup>2</sup> to 1.9 kN/m<sup>2</sup>) roof load; 50 psf or 100 psf (2.4 kN/m<sup>2</sup> or 4.8 kN/m<sup>2</sup>) floor load; open or enclosed buildings.]**

8-INCH (203 mm) WALLS <sup>6</sup>				
Wind Speed	Exposure	Distance between Shear Resisting Walls <sup>7</sup> "L" or "b" (feet)	One-story Building or Second Story of a Two-story Building	First Story of a Two-story Building
× 1.61 for km/h		× 304.8 for mm	inch × 25.4 for mm foot × 304.8 mm	
80 mph	B	32	NSR	9'-4"
		48	NSR	5'-4" DBL (D)
		64	10'-0"	7'-6" DBL (C)
	C	32	NSR	5'-4" DBL (C)
		48	1'-0"	8'-8" DBL (C)
		64	3'-4"	15'-0" (D)
	D	32	8'-8"	7'-0" (C)
		48	9'-4" (C)	10'-8" (D)
		64	10'-0" (D)	13'-8" (D)
90 mph	B	32	NSR	7'-8" DBL (C)
		48	NSR	8'-0" (D)
		64	12'-8"	12'-0" (D)
	C	32	NSR	14'-8"
		48	13'-8"	10'-0" (D)
		64	10'-8" (C)	15'-6" DBL (B)
	D	32	7'-8" (C)	11'-8" (D)
		48	12'-0" (C)	12'-8" DBL (B)
		64	11'-8" (D)	18'-4" DBL (C)
100 mph	B	32	NSR	5'-4" DBL (C)
		48	10'-0"	10'-0" (D)
		64	15'-4"	64'-8" DBL (C)

**TABLE A-21-F—MASONRY SHEAR WALL<sup>1,2,3</sup> AND DIAPHRAGM REQUIREMENTS IN HIGH-WIND AREAS<sup>4</sup>—(Part I Continued)**

8-INCH (203 mm) WALLS <sup>5</sup>				
Wind Speed	Exposure	Distance between Shear Resisting Walls <sup>7</sup> "L" or "b" (feet)	One-story Building or Second Story of a Two-story Building	First Story of a Two-story Building
× 1.61 for km/h		× 304.8 for mm	inch × 25.4 for mm foot × 304.8 mm	
100 mph (continued)	C	32	5'-4" (D)	11'-8" (D)
		48	12'-8" (C)	12'-8" DBL (C)
		64	12'-4" (D)	19'-8" DBL (C)
	D	32	5'-4" DBL (B)	9'-4" DBL (C)
		48	9'-4" (D)	14'-8" DBL (C)
		64	17'-4" (D)	21'-0" DBL (C)
110 mph	B	32	NSR	6'-0" DBL (C)
		48	12'-0"	10'-0" DBL (C)
		64	12'-8" (C)	14'-0" (D)
	C	32	5'-4" DBL (B)	9'-8" (D)
		48	12'-0" (C)	15'-4" (D)
		64	16'-8" (C)	18'-8" DBL (C)
	D	32	8'-8" (C)	11'-4" (D)
		48	12'-4" (C)	18'-0" (D)
		64	18'-8" (C)	20'-8" DBL (C)

\*NSR—No special horizontal reinforcement required for shear resistance if 5 feet 4 inches (1626 mm) long minimum.

<sup>1</sup>Cumulative shear wall length is to be at least as long as is shown in this table. However, see Figure A-21-9. The top figure is the minimum length. When required, the figure below it in parenthesis is the spacing of steel reinforcing wire installed as shown in Figure A-21-10, below. (A) = two 0.148 inch (3.76 mm) (No. 9 B.W. gage) at 16 inches (406 mm) on center, (B) = two 3/16 inch (4.76 mm) at 16 inches (406 mm) on center, (C) = two 0.148 inches (3.76 mm) (No. 9 B.W. gage) at 8 inches (203 mm) on center, (D) = two 3/16 inch (4.76 mm) at 8 inches (203 mm) on center. The symbol DBL means double these amounts. Equivalent areas of reinforcing bars spaced not over 4 feet 0 inch (1219 mm) on center may be used.

<sup>2</sup>All bearing and shear walls are to be in-plane with vertical reinforcement, when required, extending from one floor to the other as dictated in Tables A-21-C-1 through A-21-C-5.

<sup>3</sup>Minimum bond beam shall be 100 miles per hour (mph) (161 km/h), Exposure B; 90 mph (145 km/h), Exposure B, and 80 mph (129 km/h), Exposures B and C, one No. 4; 100 mph (161 km/h), Exposure C; 80 and 90 mph (129 and 145 km/h); Exposures C and D, two No. 4; all others two No. 5.

<sup>4</sup>Table is adjusted to include provisions for Seismic Zones 0, 1 and 2.

<sup>5</sup>Cross walls are to be at least twice as long as shown in the table for shear walls. The tributary width (L/2) shall be the distance used in the third column above to find minimum reinforcement and length.

<sup>6</sup>For walls which width is equal to or less than half its height, add an extra No. 5 vertical bar at each end.

<sup>7</sup>Use 32-foot (9753 mm) requirements for distances less than 32 feet (9754 mm). Also use it for bearing walls used as shear walls.

**TABLE A-21-F—MASONRY SHEAR WALL<sup>1,2,3</sup> AND DIAPHRAGM REQUIREMENTS IN HIGH-WIND AREAS<sup>4</sup>—(Continued)**

**Part II—Wood floor and roof diaphragms and connections<sup>8,9</sup>  
[All wall heights 8 feet to 12 feet (2438 mm to 3657 mm).]**

FRAMING OF DOUGLAS FIR-LARCH OR SOUTHERN PINE					
Wind Speed × 1.61 for km/h	Exposure	Distance between Shear Walls <sup>10</sup> "L" or "b" (feet) × 304.8 for mm	Minimum Wood Structural Panel/Particleboard Size <sup>9</sup> and Nailing <sup>11,12</sup>		
			Thickness (inches) × 25.4 for mm	Common Nail Size (penny)	Nail Spacing (inches) × 25.4 for mm
80 mph	B	16	5/16	6	6 o.c.
		32	3/8	6	6 o.c.
		48	3/8	8	6 o.c.
		64	3/8	8	6 o.c.
	C	16	3/8	8	6 o.c.
		32	1/2 or 15/32	8	6 o.c.
		48	1/2 or 15/32	10	6 o.c.
		64	5/8 or 19/32	10	6 o.c.
	D	16	1/2 or 15/32	8	6 o.c.
		32	5/8 or 19/32	10	6 o.c.
		48	1/2 or 15/32 blocked	8	4/6 o.c.
		64	1/2 or 15/32 blocked	8	4/6 o.c.
90 mph	B	16	5/16	6	6 o.c.
		32	3/8	8	6 o.c.
		48	3/8	8	6 o.c.
		64	3/8	8	6 o.c.
	C	16	1/2 or 15/32	10	6 o.c.
		32	3/8 blocked	8	4/6 o.c.
		48	3/8 blocked	8	4/6 o.c.
		64	5/8 or 19/32 blocked	10	6 o.c.
	D	16	5/8 or 19/32	10	6 o.c.
		32	1/2 or 15/32 blocked	10	4/6 o.c.
		48	1/2 or 15/32 blocked	10	4/6 o.c.
		64	Design required or provide extra cross walls		
100 mph	B	16	3/8	8	6 o.c.
		32	1/2 or 15/32	8	6 o.c.
		48	1/2 or 15/32	8	6 o.c.
		64	5/8 or 19/32	10	6 o.c.

**TABLE A-21-F—MASONRY SHEAR WALL<sup>1,2,3</sup> AND DIAPHRAGM REQUIREMENTS IN HIGH-WIND AREAS<sup>4</sup>—(Part II Continued)**

FRAMING OF DOUGLAS FIR-LARCH OR SOUTHERN PINE					
Wind Speed	Exposure	Distance between Shear Walls <sup>10</sup> "L" or "b" (feet)	Minimum Wood Structural Panel/Particleboard Size <sup>9</sup> and Nailing <sup>11,12</sup>		
			Thickness (inches)	Common Nail Size (penny)	Nail Spacing (inches)
× 1.61 for km/h		× 304.8 for mm	× 25.4 for mm		× 25.4 for mm
100 mph (continued)	C	16	3/8 blocked	8	4/6 o.c.
		32	5/8 or 19/32 blocked	10	4/6 o.c.
		48	5/8 or 19/32 blocked	10	4/6 o.c.
		64	Design required or provide extra cross walls		
	D	16	1/2 or 15/32 blocked	10	4/6 o.c.
		32	5/8 or 19/32 blocked	10	4/6 o.c.
		48	Design required or provide extra cross walls		
		64	Design required or provide extra cross walls		
110 mph	B	16	1/2 or 15/32	8	6 o.c.
		32	1/2 or 15/32	10	6 o.c.
		48	5/8 or 19/32	10	6 o.c.
		64	1/2 or 15/32 blocked	8	4/6 o.c.
	C	16	1/2 or 15/32 blocked	8	4/6 o.c.
		32	5/8 or 19/32 blocked	10	4/6 o.c.
		48	Design required or provide extra cross walls		
		64	Design required or provide extra cross walls		
	D	16	5/8 or 19/32 blocked	10	4/6 o.c.
		32	Design required or provide extra cross walls		
		48	Design required or provide extra cross walls		
		64	Design required or provide extra cross walls		

<sup>8</sup>These requirements represent the maximum values for a diaphragm which is within a maximum 32-foot by 64-foot (9.75 m by 19.5 m) module surrounded by shear walls, cross walls or bearing walls. (See Figure A-21-9.)

<sup>9</sup>See Tables 23-I-S-1 and 23-I-S-2 for minimum sizes depending on span between joists.

<sup>10</sup>See Figure A-21-9 for "L" and "b."

<sup>11</sup>The wood structural panel/particleboard (all grades) thickness is given first. The nailing size and boundary/supported edge spacing is shown next (see Tables 23-I-J-1 and 23-I-J-2). Blocking of unsupported edges is stated where required. Twelve-inch (305 mm) spacing required in the field of the roof/floor. Boundary nailing is required over interior walls [see Figure A-21-12 (b)].

<sup>12</sup>Use Case 1 for unblocked diaphragms and any case for blocked diaphragms (see Tables 23-I-J-1 and 23-I-J-2 for illustration).

**TABLE A-21-G—MINIMUM WALL CONNECTION REQUIREMENTS IN HIGH-WIND AREAS  
Precast Hollow-core Plank Floors and Roofs**

**Spacing of No. 4 bent reinforcing bar in block or brick walls connected to precast concrete planks<sup>1,2</sup>**

WIND SPEED AND EXPOSURE	EXTERIOR WALLS	INTERIOR WALLS
	× 25.4 for mm	
90 mph (145 km/h) Exposure C and less 100 mph (161 km/h) Exposure B	32" o.c.	16" o.c.
90 mph (145 km/h) Exposure D 100 mph (161 km/h) Exposure C 110 mph (177 km/h) Exposure B	24" o.c.	12" o.c.
100 mph (161 km/h) Exposure D 110 mph (177 km/h) Exposures C and D	16" o.c.	12" o.c.

<sup>1</sup>This table assumes maximum wall height of 12 feet (3.7 m) and a width-to-length ratio of diaphragm between shear walls of 3:1 or less.

<sup>2</sup>The precast planks shall be designed as shall the walls and footings supporting them.

**TABLE A-21-H—MINIMUM HOLD-DOWN REQUIREMENTS IN HIGH-WIND AREAS  
Steel Floors and Roofs**

WIND SPEED AND EXPOSURE	MAXIMUM SPACING OF ROOF JOISTS WITH CONNECTION SHOWN <sup>1,2,3</sup>
	× 25.4 for mm
100 mph (161 km/h) Exposure B 90 mph (145 km/h) Exposures B and C 80 mph (129 km/h) Exposures B, C and D	48"
110 mph (177 km/h) Exposure B 100 mph (161 km/h) Exposure C	30"
110 mph (177 km/h) Exposures C and D 100 mph (161 km/h) Exposure D	Design required

<sup>1</sup>Maximum span is 32 feet (9.75 m) to bearing walls.

<sup>2</sup>Joists and decking to be designed.

<sup>3</sup>Bottom chord of joists to be braced for reversal of stresses caused by wind uplift.

**TABLE A-21-I—DIAGONAL BRACING REQUIREMENTS FOR GABLE-END WALL<sup>1,2</sup> ROOF PITCH 3:12 to 5:12**

EXPOSURE	BASIC WIND SPEED (mph)							
	× 1.61 for km/h							
	80		90		100		110	
	3:12 (25%)	4:12 (33%) and 5:12 (42%)	3:12 (25%)	4:12 (33%) and 5:12 (42%)	3:12 (25%)	4:12 (33%) and 5:12 (42%)	3:12 (25%)	4:12 (33%) and 5:12 (42%)
× 25.4 for mm								
B	I at 48" o.c.	III at 48" o.c.	I at 48" o.c.	III at 48" o.c.	I at 24" o.c.	III at 24" o.c.	I at 24" o.c.	III at 24" o.c.
C	I at 24" o.c.	III at 48" o.c.	I at 24" o.c.	III at 24" o.c.	II at 24" o.c.	IV at 24" o.c.	II at 24" o.c.	IV at 24" o.c.
D	I at 24" o.c.	III at 48" o.c.	II at 24" o.c.	IV at 24" o.c.	II at 24" o.c.	IV at 24" o.c.	Two-II at 24" o.c.	Two-III at 24" o.c.

- <sup>1</sup> I = 2-inch by 4-inch brace, one clip angle (51 mm × 102 mm).
- II = 2-inch by 4-inch brace, two clip angles (one each side) (51 mm × 102 mm).
- III = 3-inch by 4-inch brace, one clip angle (76 mm × 102 mm).
- IV = 3-inch by 4-inch brace, two clip angles (one each side) (76 mm × 102 mm).

The spacing requirements of the brace are shown below the symbol.  
<sup>2</sup>See Figures A-21-17 and A-21-18 for details and size of clip angles.

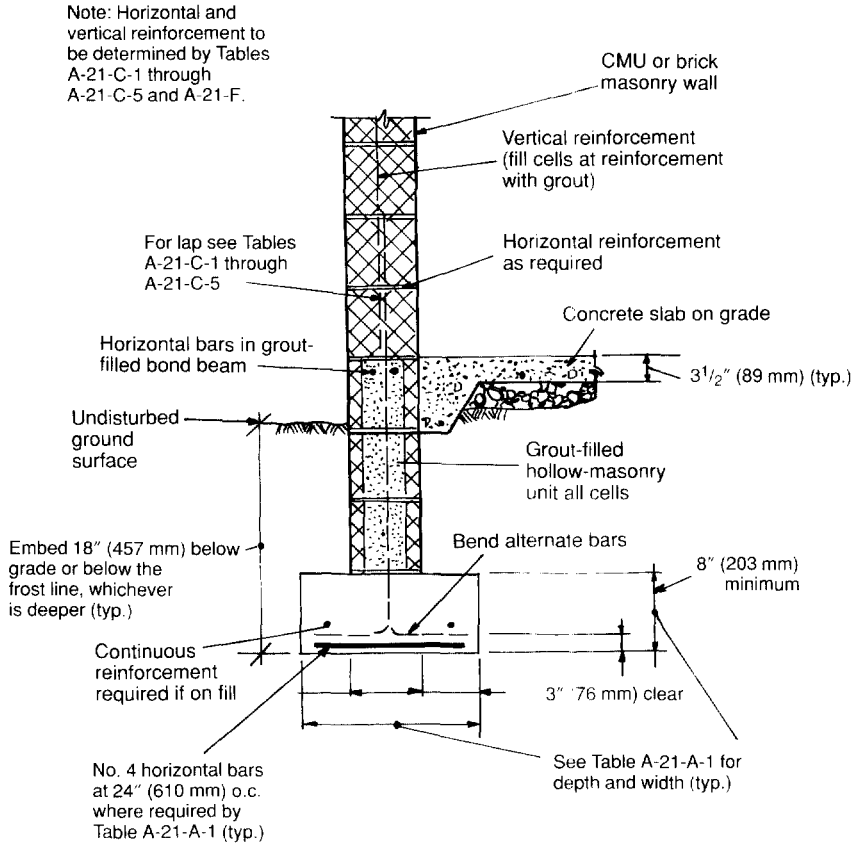

**HOLLOW-MASONRY UNIT EXTERIOR FOUNDATION WALL**

**FIGURE A-21-1—VARIOUS DETAILS OF FOOTINGS**  
 (See Tables A-21-A-1 and A-21-A-2 for widths.)

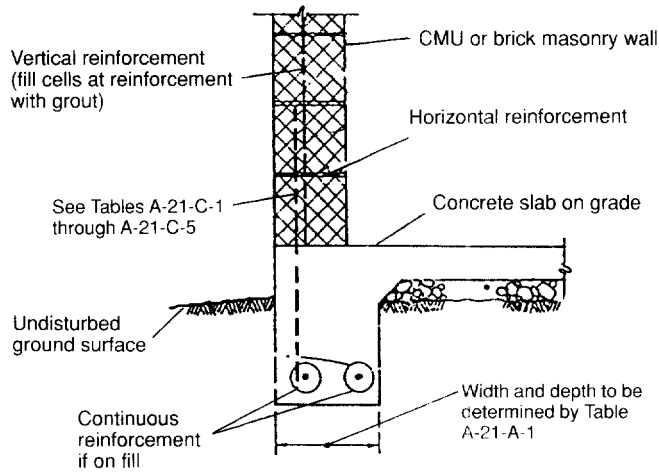

**GRADE BEAM OR CONTINUOUS CONCRETE SLAB—TURN DOWN**

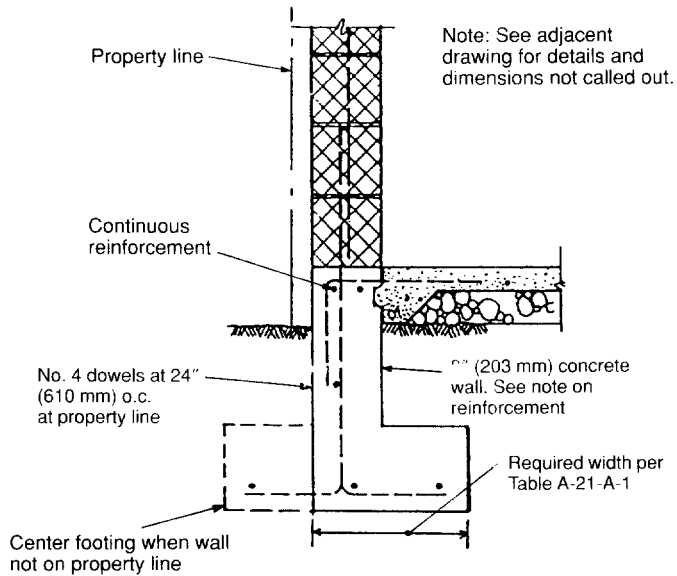

**HOLLOW-MASONRY UNIT CONCRETE EXTERIOR FOUNDATION WALL**

**FIGURE A-21-1—VARIOUS DETAILS OF FOOTINGS—(Continued)**  
 (See Tables A-21-A-1 and A-21-A-2 for widths.)

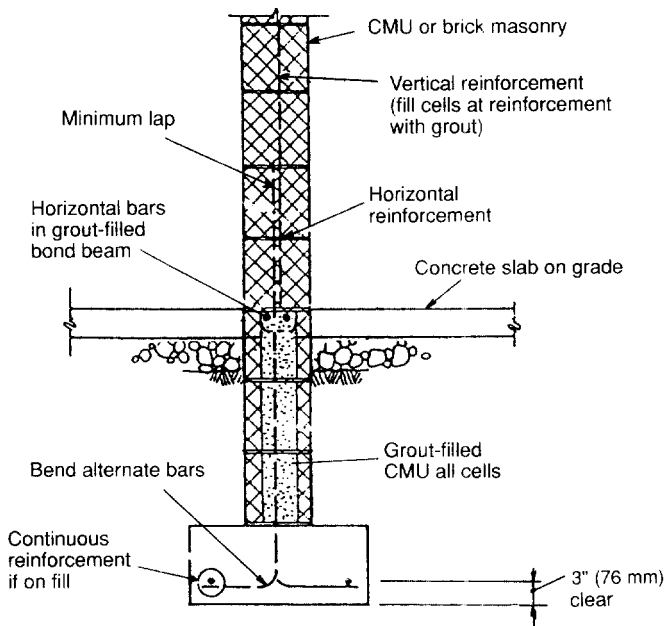

**HOLLOW-MASONRY UNIT INTERIOR FOUNDATION WALL**

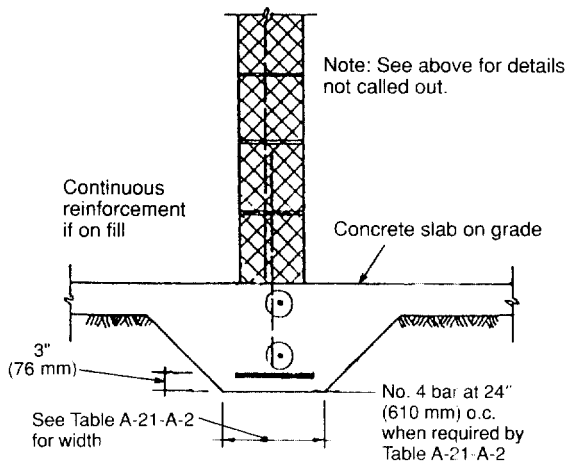

**CONCRETE INTERIOR NONBEARING WALL FOOTING**

**FIGURE A-21-1—VARIOUS DETAILS OF FOOTINGS—(Continued)**  
 (See Tables A-21-A-1 and A-21-A-2 for widths.)

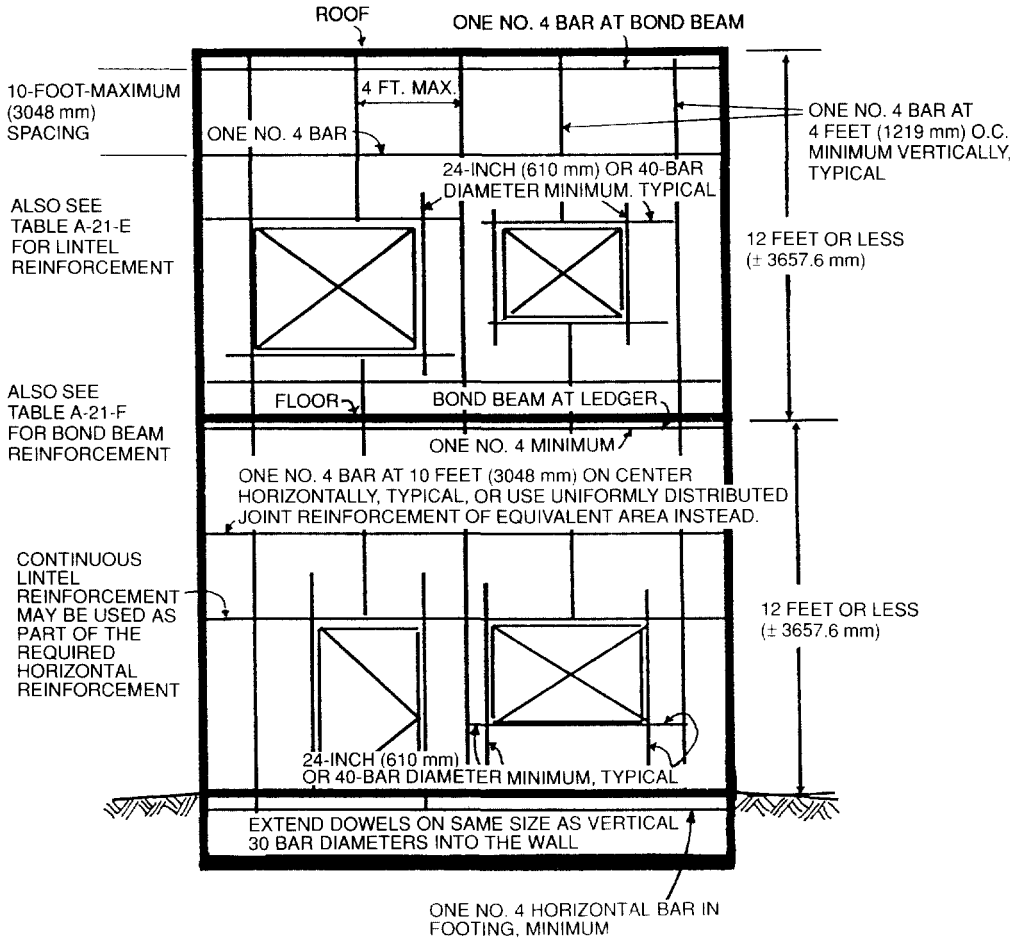
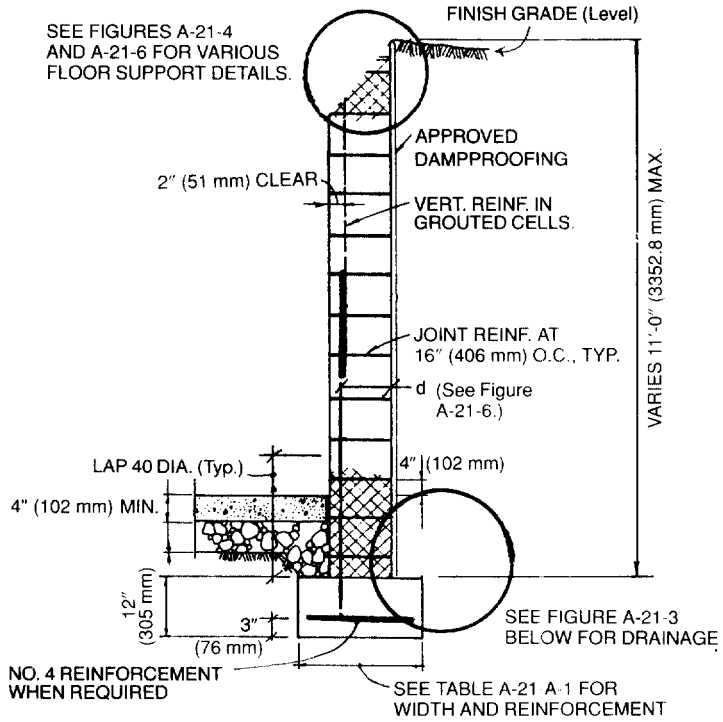
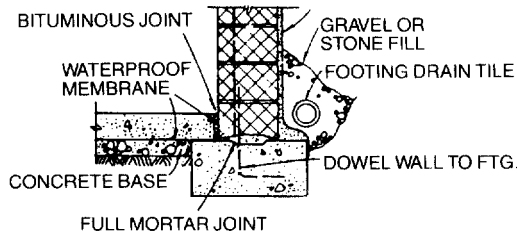

FIGURE A-21-2—MINIMUM MASONRY WALL REQUIREMENTS IN SEISMIC ZONE 2



**BASEMENT WALL**



**FIGURE A-21-3—BELOW-GRADE WALL AND DRAINAGE DETAILS**

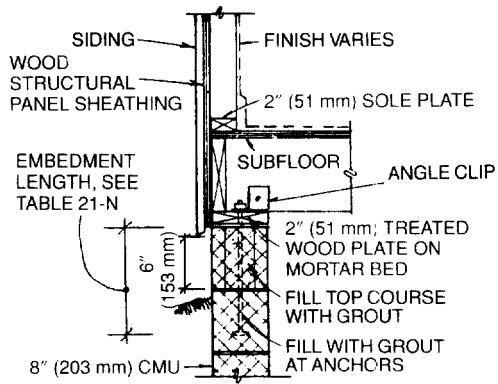

NOTE: SEE ADJACENT DRWG. FOR DET. NOT CALLED OUT

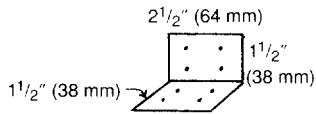
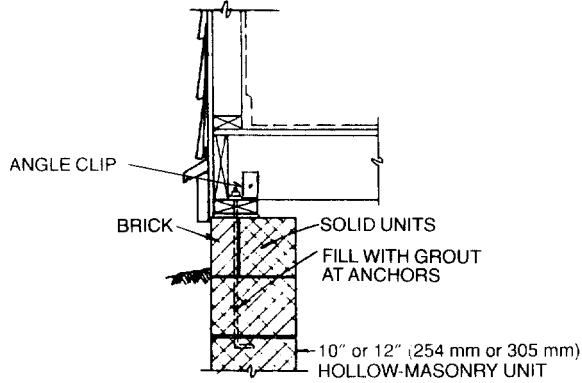

ANGLE CLIP: FOUR 8d COMMON NAILS EACH LEG. USE MINIMUM 0.047 INCH (1.04 mm) (NO. 18 GALVANIZED SHEET GAGE) (See Table A-21-B for minimum spacing. Where two clips are required, place one clip on each side of joist.)

**FIGURE A-21-4—HOLLOW-MASONRY UNIT FOUNDATION WALL—WOOD FLOOR**

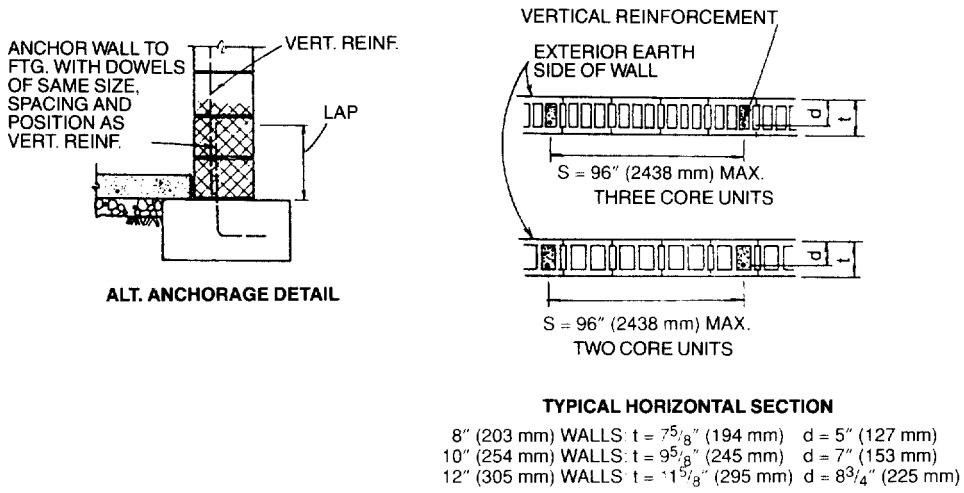
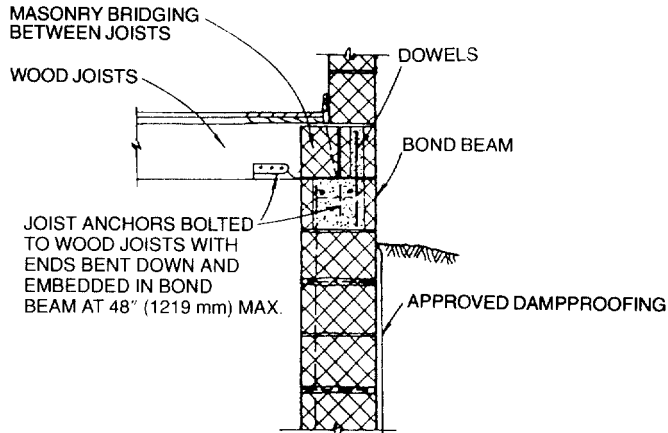
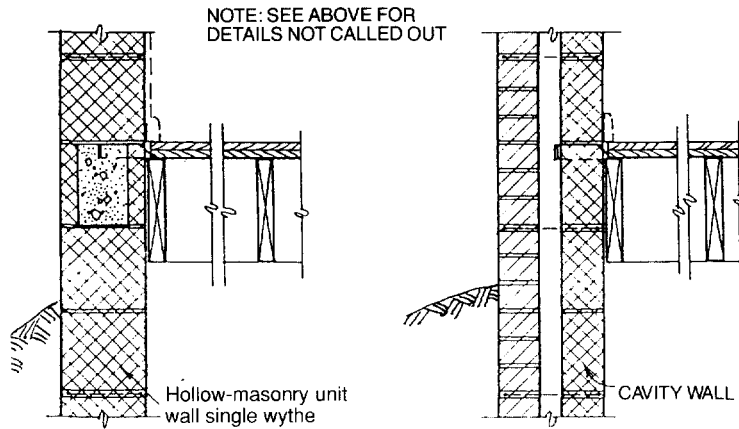
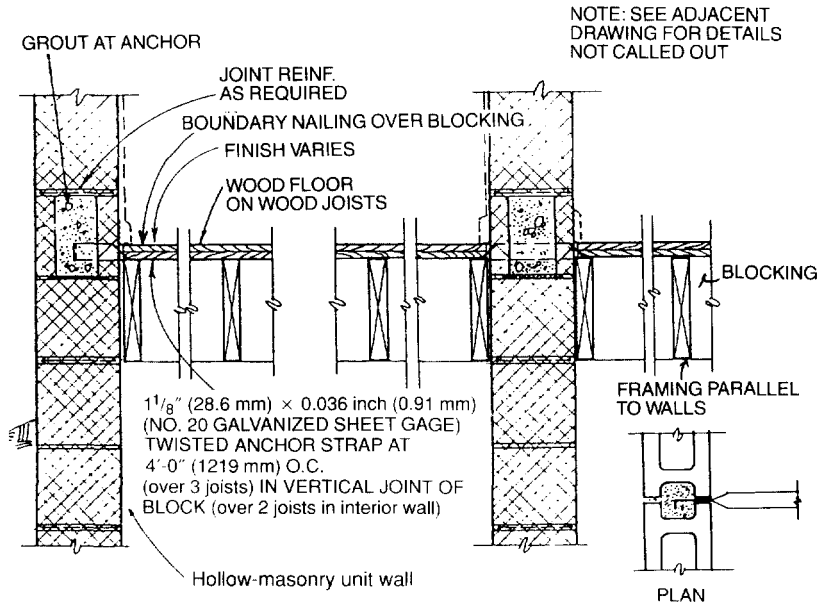

FIGURE A-21-5—PLACEMENT OF REINFORCEMENT



(A) HOLLOW-MASONRY UNIT WALL—WOOD FLOOR

FIGURE A-21-6—VARIOUS CONNECTIONS OF FLOORS TO BASEMENT WALLS



(B) WOOD FLOOR, JOISTS PARALLEL TO WALL

FIGURE A-21-6—VARIOUS CONNECTIONS OF FLOORS TO BASEMENT WALLS—(Continued)

NOTE: HORIZONTAL AND VERTICAL REINFORCEMENT TO BE DETERMINED BY TABLES A-21-C-1 THROUGH A-21-C-5

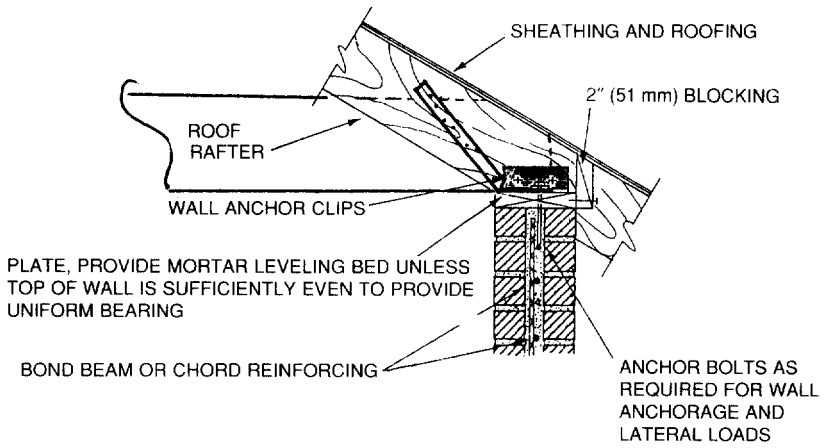
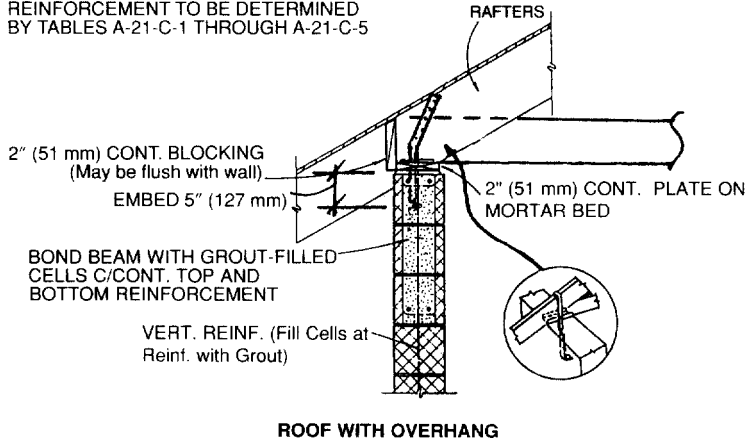

**FIGURE A-21-7—VARIOUS DETAILS ASSOCIATED WITH TABLE A-21-D (Uplift Resistance)**

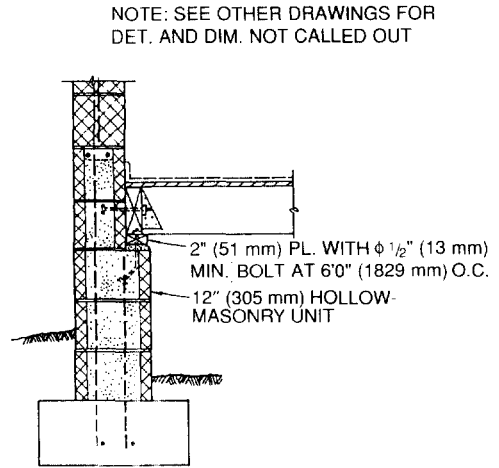
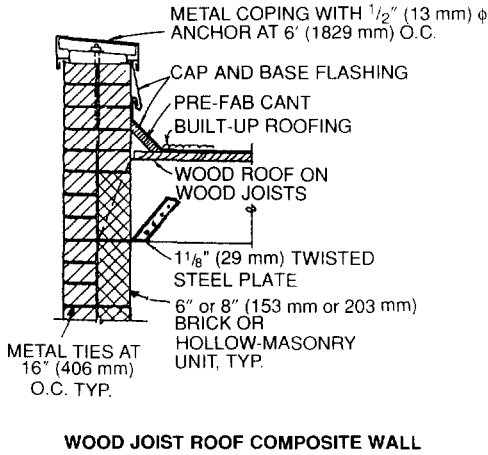

NOTE: HORIZONTAL AND VERTICAL REINFORCEMENT PER TABLES A-21-C-1 THROUGH A-21-C-5

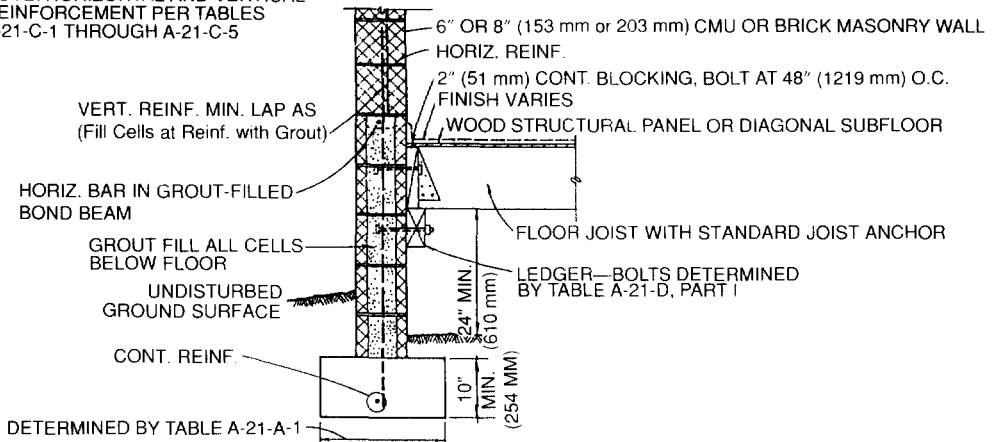

**FIGURE A-21-7—VARIOUS DETAILS ASSOCIATED WITH TABLE A-21-D (Uplift Resistance)—(Continued)**

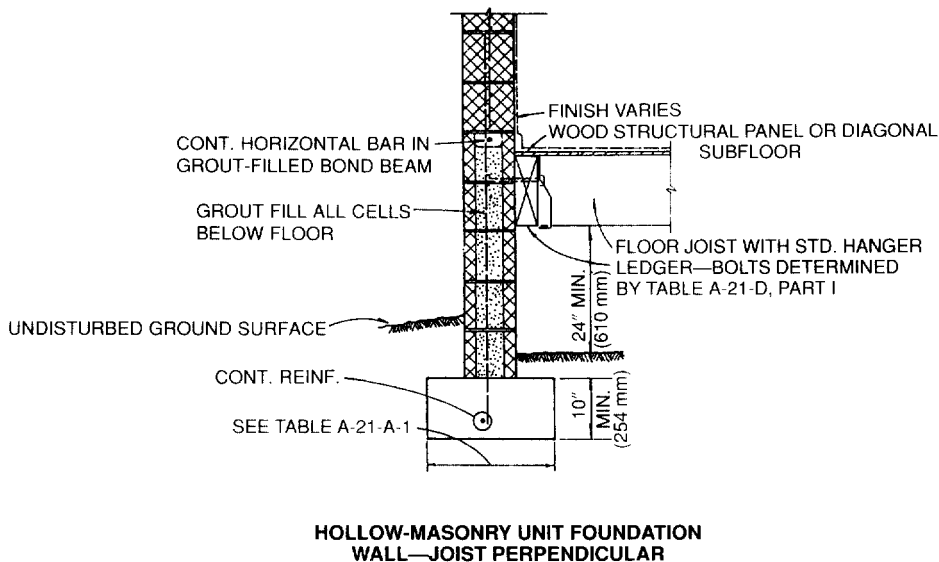
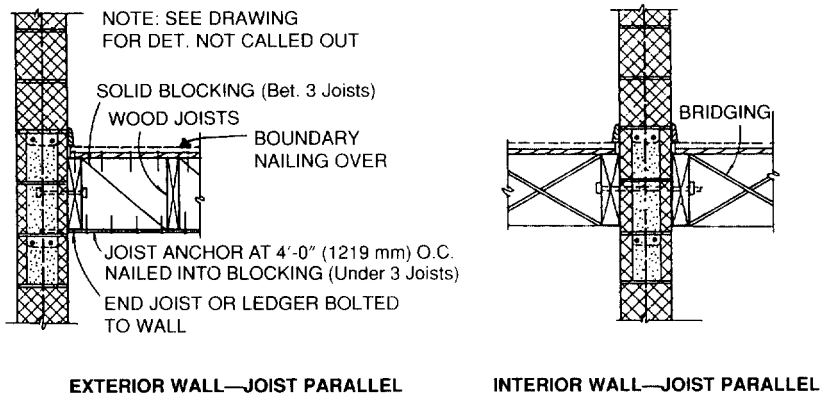
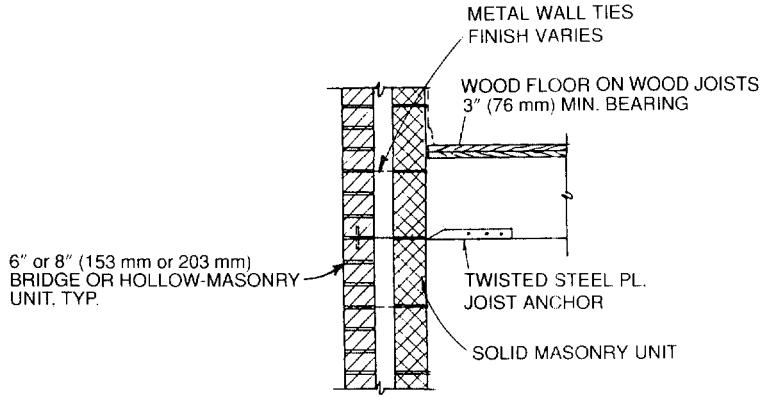
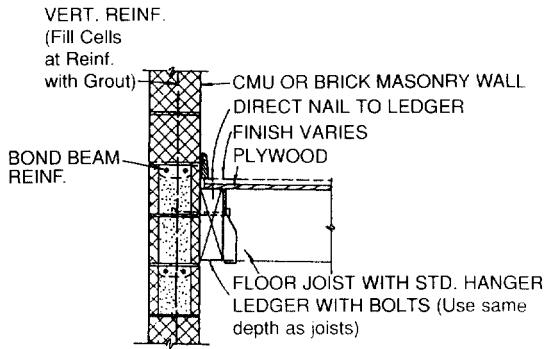

FIGURE A-21-7—VARIOUS DETAILS ASSOCIATED WITH TABLE A-21-D (Uplift Resistance)—(Continued)



WOOD FLOOR



EXTERIOR WALL—  
JOIST PERPENDICULAR

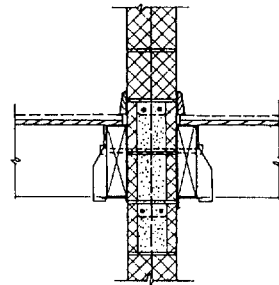

INTERIOR WALL—  
JOIST PERPENDICULAR

FIGURE A-21-7—VARIOUS DETAILS ASSOCIATED WITH TABLE A-21-D (Uplift Resistance)—(Continued)

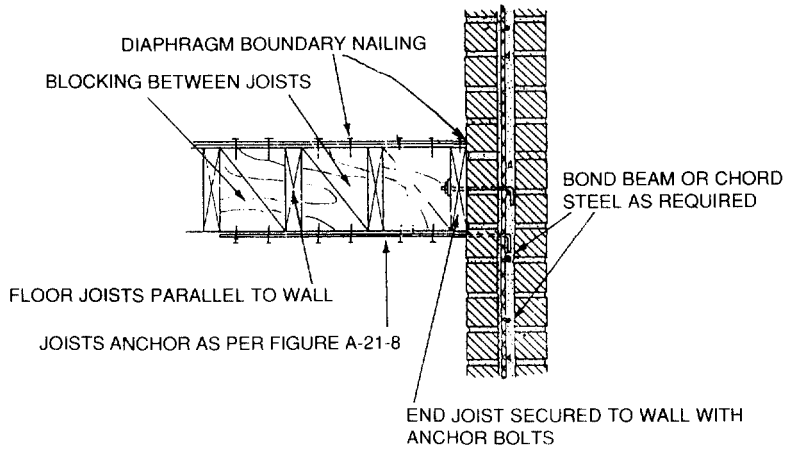
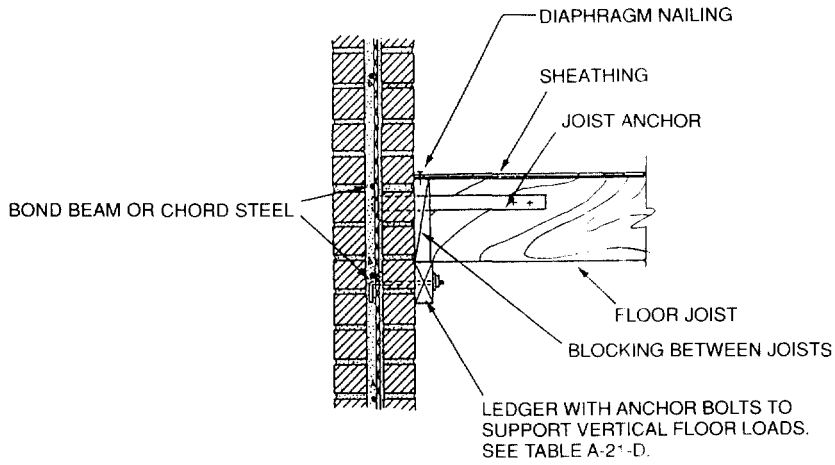

**FIGURE A-21-7—VARIOUS DETAILS ASSOCIATED WITH TABLE A-21-D (Uplift Resistance)—(Continued)**

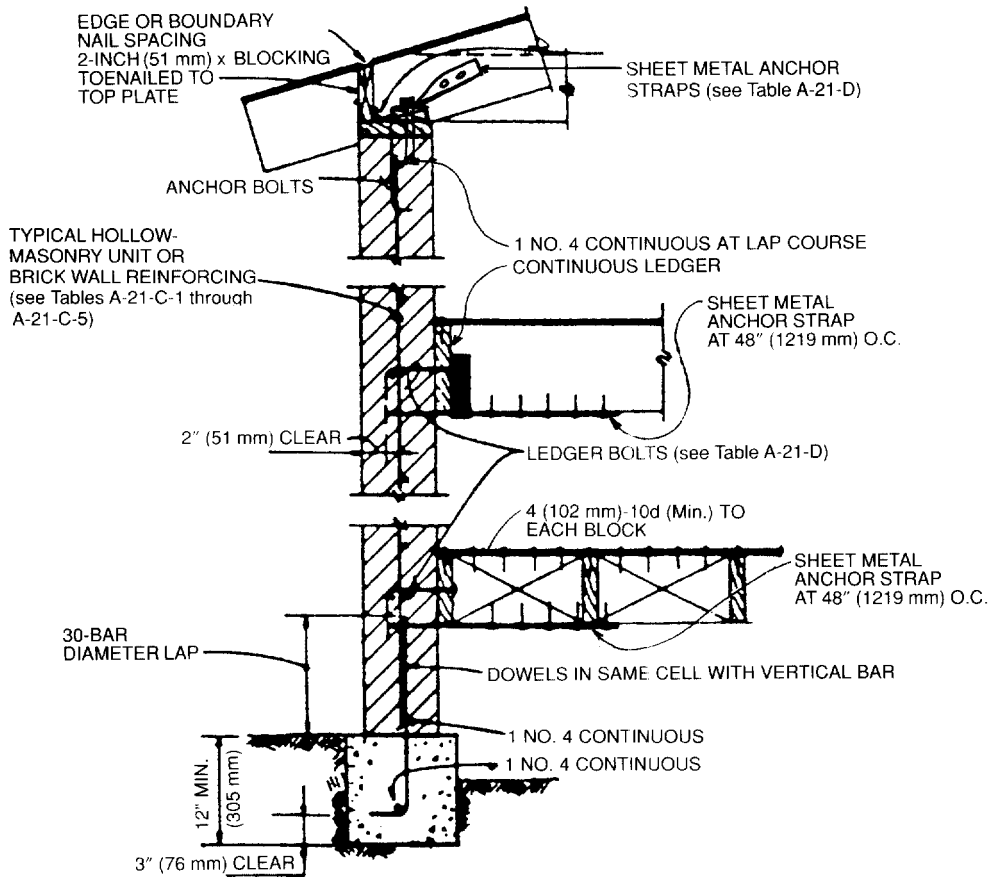
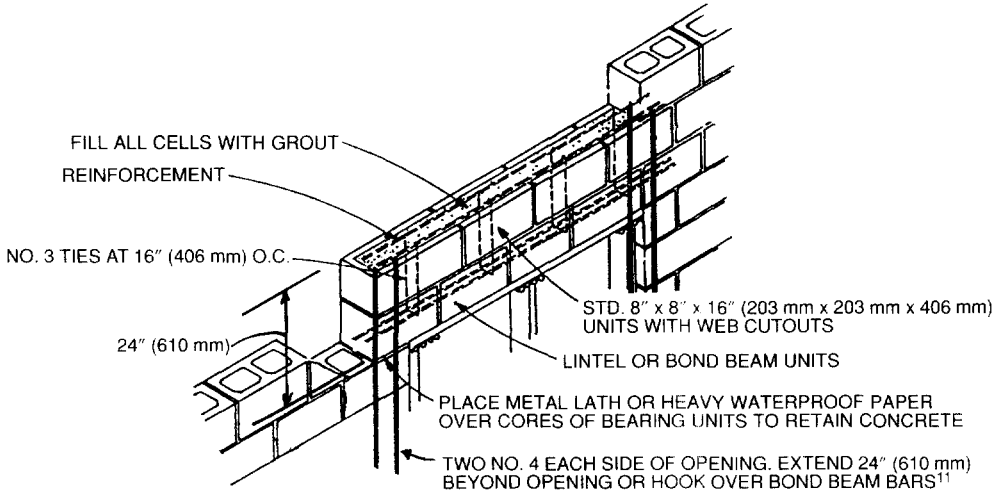
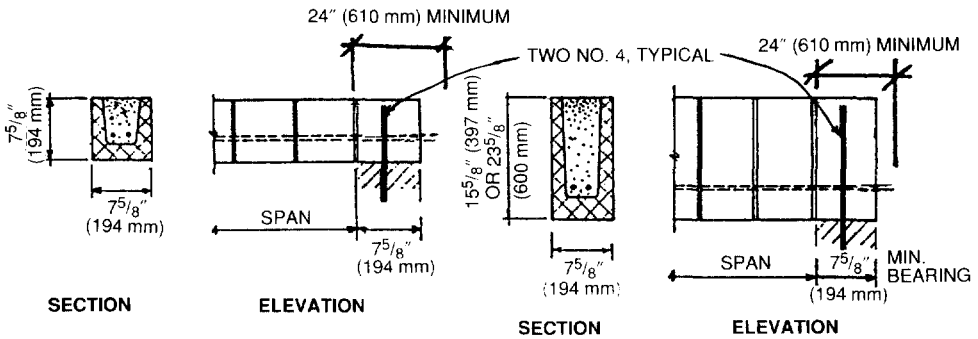

FIGURE A-21-8—CONTINUOUS LOAD PATH



**REINFORCING DETAILS**



**WITHOUT STIRRUPS**

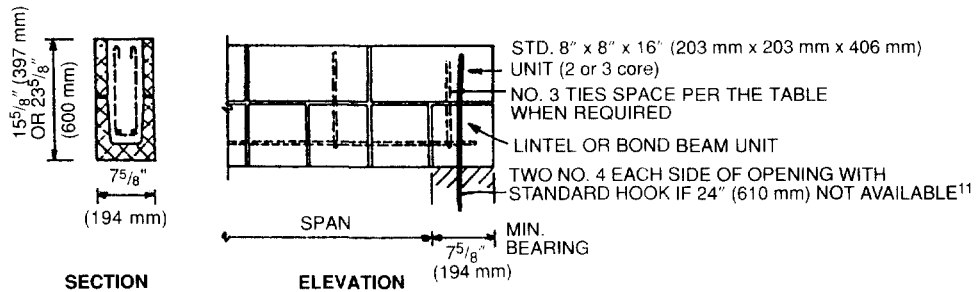

**WITH STIRRUPS**

**FIGURE A-21-8—CONTINUOUS LOAD PATH—(Continued)**

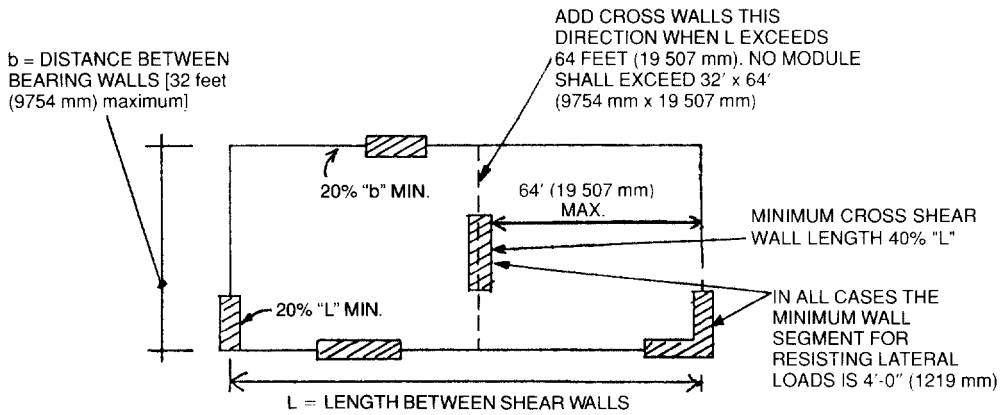

FIGURE A-21-9—SPACING AND LENGTHS OF SHEAR WALLS

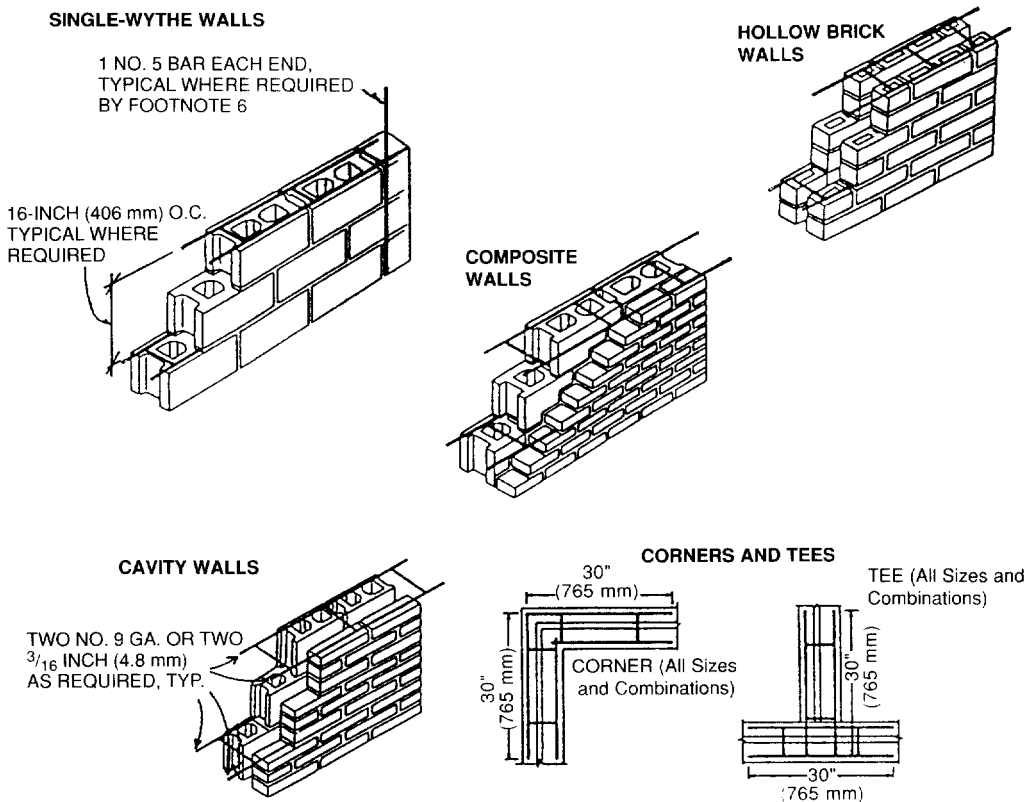
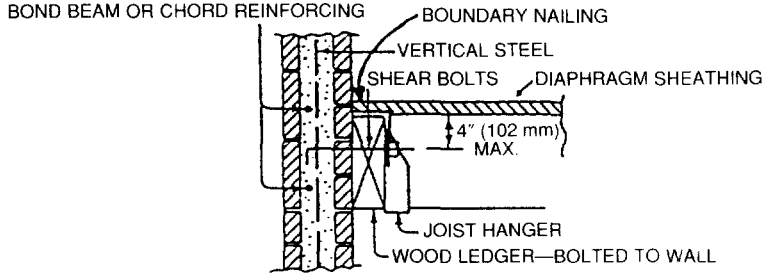
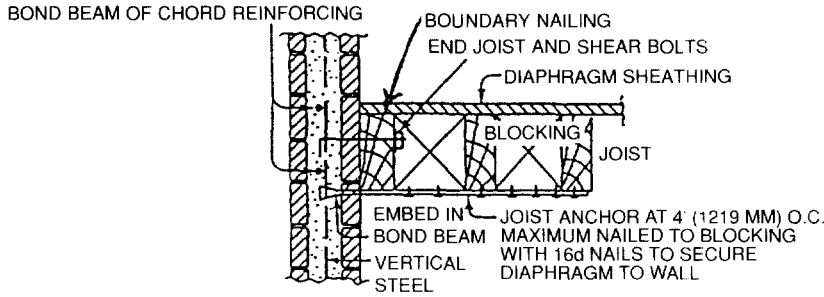

FIGURE A-21-10—SPACING OF STEEL REINFORCING WIRE



(a) FLOOR JOISTS PERPENDICULAR TO WALL JOIST HANGER SUPPORTS



(b) FLOOR JOISTS PARALLEL TO WALL

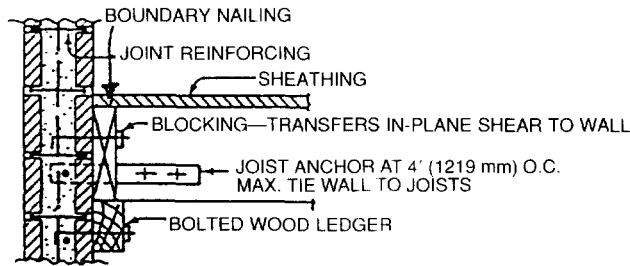

(c) WOOD LEDGER FLOOR JOIST SUPPORT

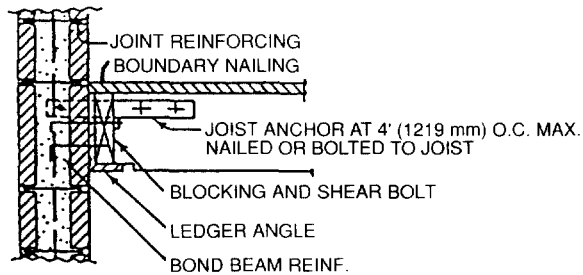

(d) STEEL LEDGER FLOOR JOIST SUPPORT

FIGURE A-21-11—FLOOR-TO-WALL CONNECTION DETAILS

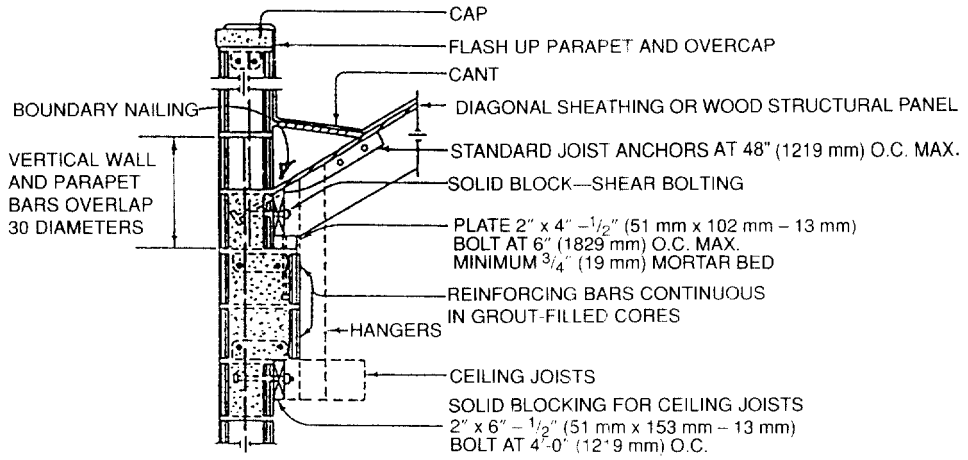

(a) EXTERIOR WALL SUPPORT

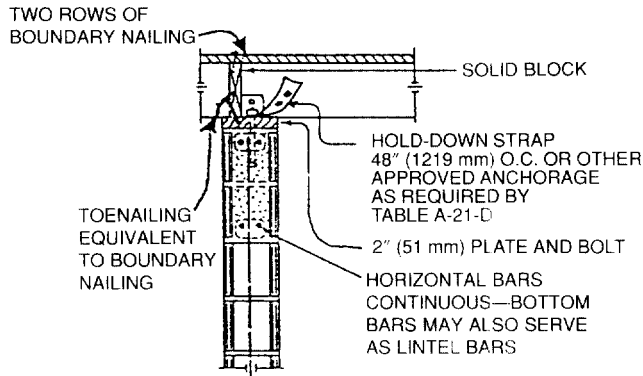

(b) INTERIOR WALL SUPPORT BOND-BEAM SUPPORTS

FIGURE A-21-12—ROOF-TO-WALL CONNECTION DETAILS

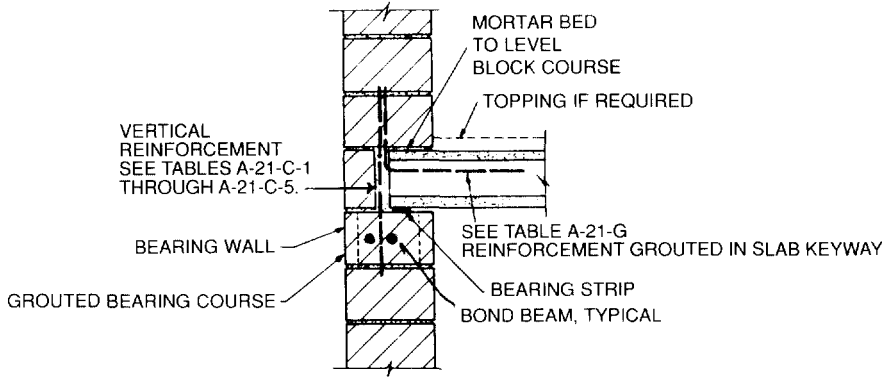

(a) SLAB PERPENDICULAR TO WALL

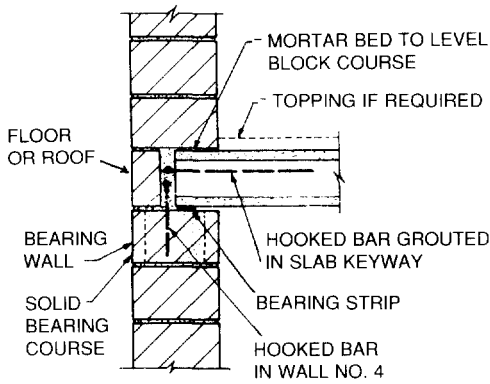

(b) ALTERNATE CONNECTION PERPENDICULAR TO WALL

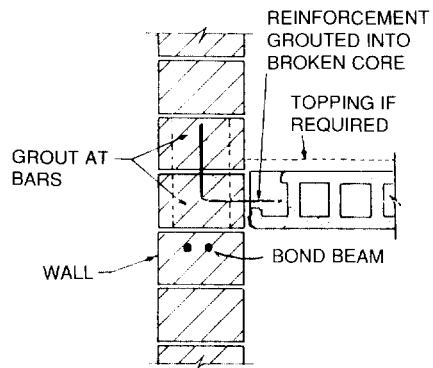

(c) SLAB PARALLEL WITH WALL

FIGURE A-21-13—VARIOUS TYPES OF WALL CONNECTIONS

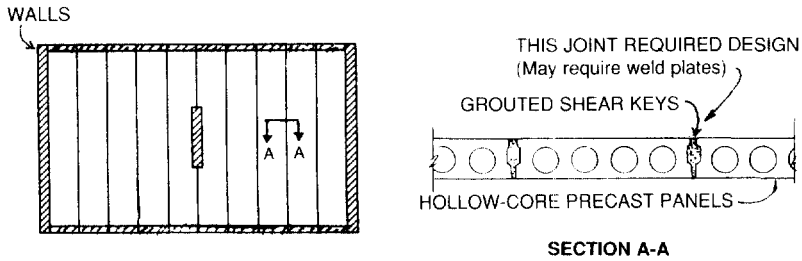

(d) PLAN VIEW OF FLOOR OR ROOF AND CROSS SECTION THROUGH PLANKS

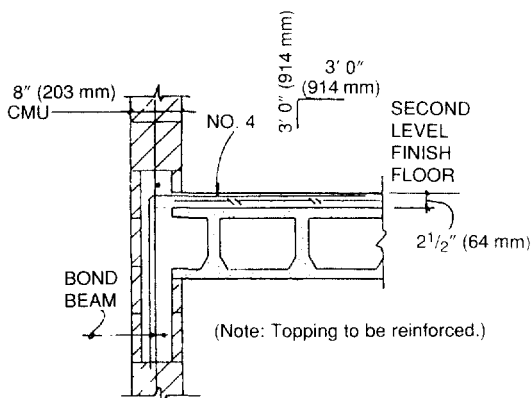

(e) ALTERNATE PLANK PARALLEL WITH WALL WITH TOPPING

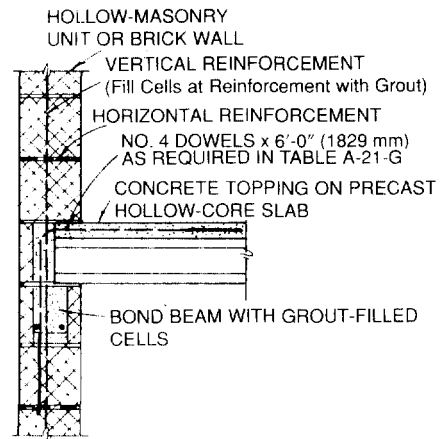

(f) ALTERNATE WITH TOPPING

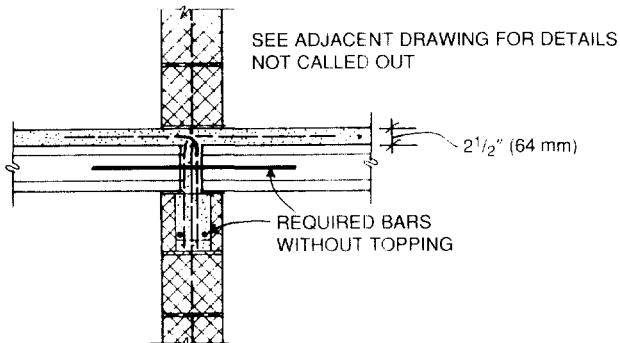

(g) INTERIOR WALL MINIMUM CONNECTION

FIGURE A-21-13—VARIOUS TYPES OF WALL CONNECTIONS—(Continued)

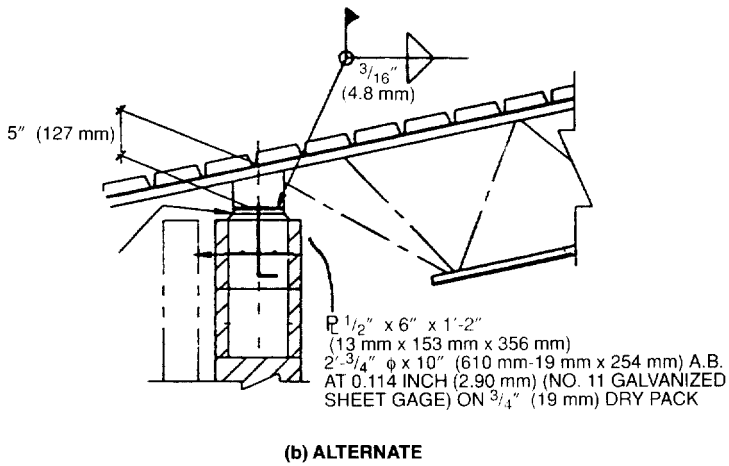
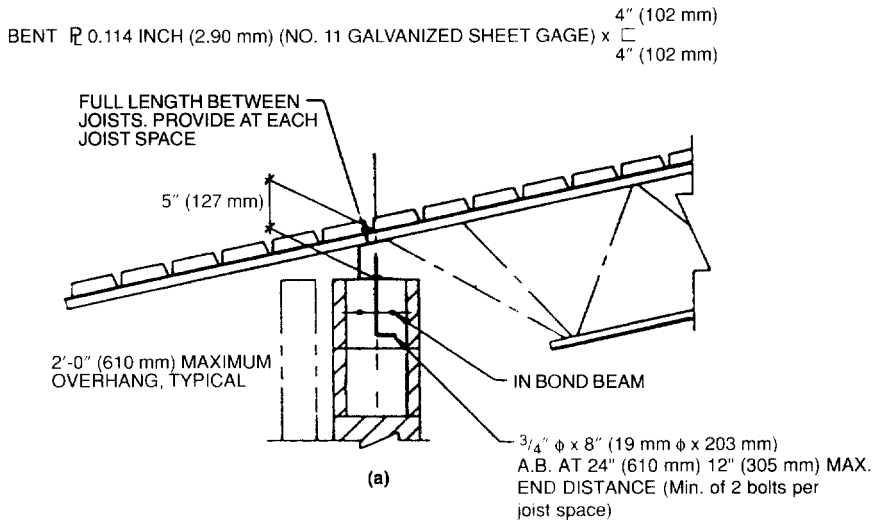

FIGURE A-21-14—EXTERIOR WALL DETAILS

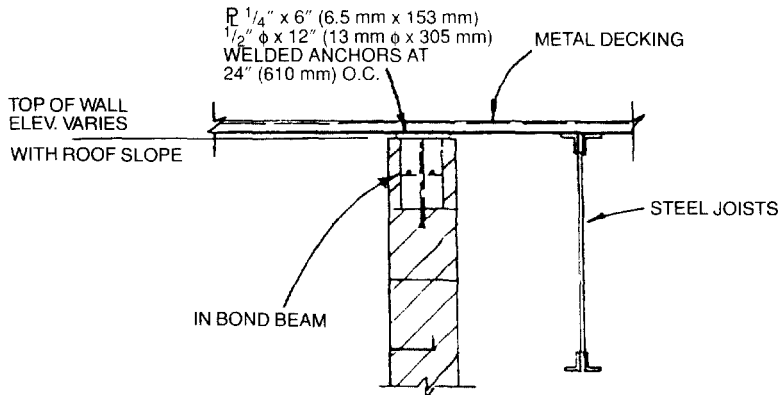
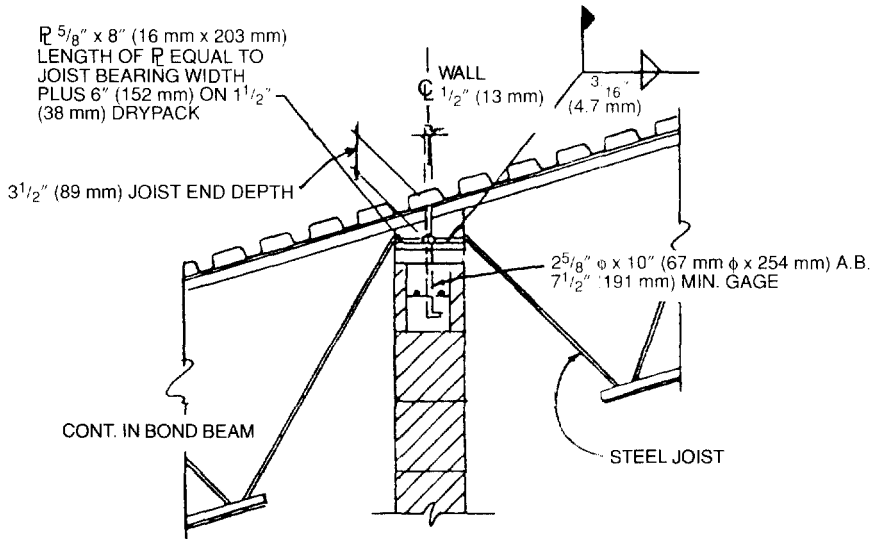
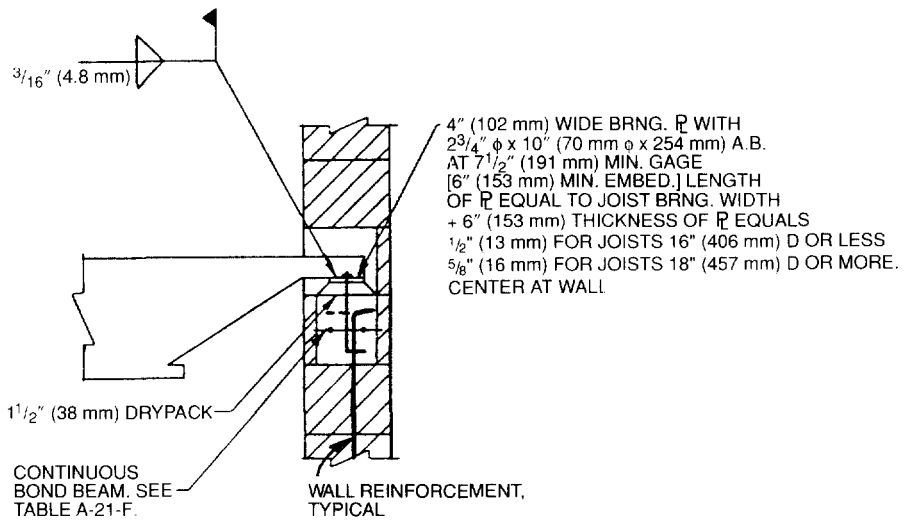
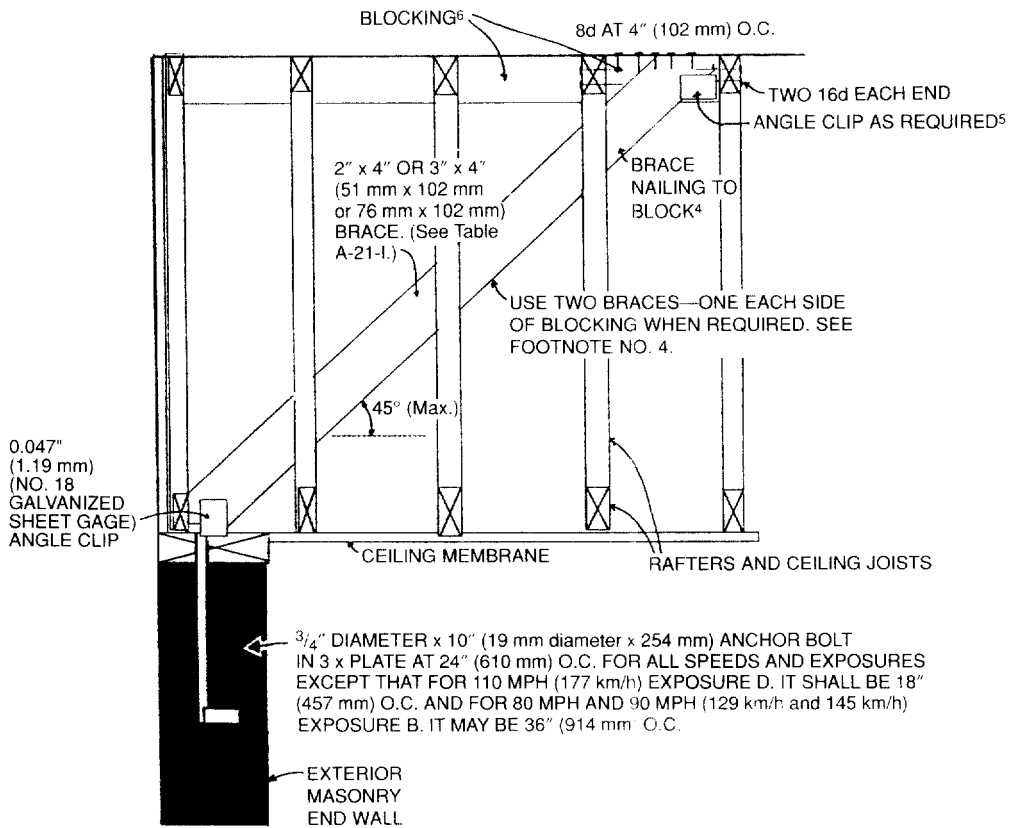

FIGURE A-21-15—INTERIOR WALL DETAILS



**NOTE:**  
BASE PLATE TO BE SET OVER FULLY GROUTED MASONRY COURSE FOR FULL 100 PERCENT BEARING AT BOTTOM SIDE OF PLATE.

**FIGURE A-21-16—FLOOR DETAILS  
(Design Required for Joists and Wall)**



- <sup>1</sup>For roof slopes up to 5 units vertical in 12 units horizontal (42%); see Table A-21-I.
- <sup>2</sup>See Detail 2, Table A-21-B, for size of angle clip.
- <sup>3</sup>Angle clip one side or both sides as required by Table A-21-I.
- <sup>4</sup>Use six 16d nails to fasten brace to block, except use two braces and six 16d nails each for 110 miles per hour (mph) (177 km/h), Exposure D. Place on brace on each side block.
- <sup>5</sup>Add angle clip each end of block for 90 mph (145 km/h), Exposure D. and 100 and 110 mph (161 and 177 km/h) for Exposures C and D.
- <sup>6</sup>Use 2-inch × 6-inch (51 mm × 153 mm) block with 2-inch (51 mm) × brace, 2-inch × 8-inch (51 mm × 203 mm) block with 3-inch × (76 mm) brace.

FIGURE A-21-17—DIAGONAL BRACING OF GABLE-END WALL<sup>1</sup>

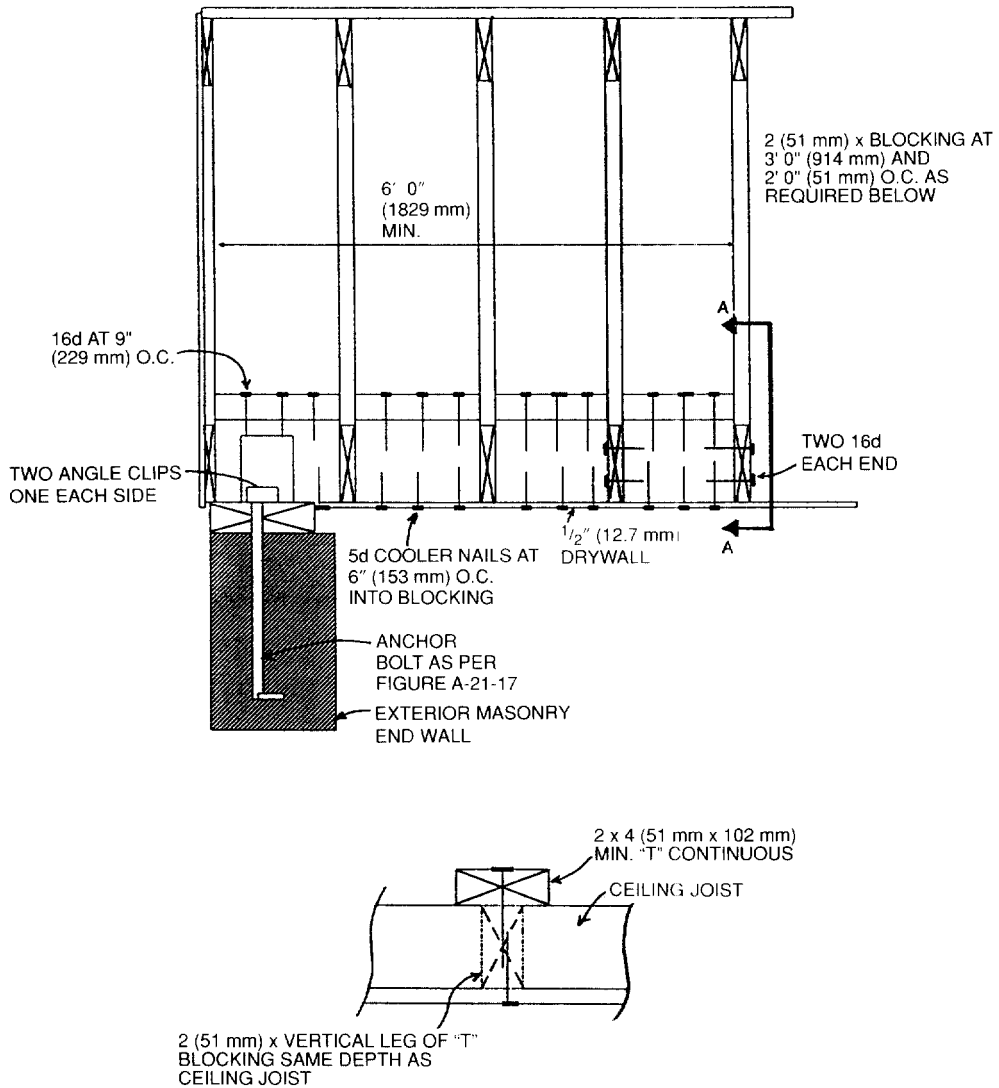

DETAIL A-A

**NOTE:** This detail may be used for flat roofs, also, except use full height blocking connected to roof sheathing in lieu of "T."

2 x 4 (51 mm x 102 mm) "T" at 36 inches (914 mm) on center—90 miles per hour (mph) (145 km/h) Exposure C and less, and 100 mph and 110 mph (161 km/h and 177 km/h), Exposure B.

2 x 4 (51 mm x 102 mm) "T" at 24 inches (610 mm) on center—required for 90 mph (145 mm) Exposure D, 100 mph and 110 mph (161 km/h and 177 km/h) Exposures C and D.

See Figure A-21-4 for details of clip angle and connections.

FIGURE A-21-18—ALTERNATE HORIZONTAL BRACING OF GABLE-END WALL

## Appendix Chapter 23

### CONVENTIONAL LIGHT-FRAME CONSTRUCTION IN HIGH-WIND AREAS

#### SECTION 2365 — GENERAL

**2365.1 Purpose.** The provisions of this chapter are intended to promote public safety and welfare by reducing the risk of wind-induced damages to conventional light-frame construction.

**2365.2 Scope.** This chapter applies to regular-shaped buildings which have roof structural members spanning 32 feet (9.75 m) or less, are not more than three stories in height, are of conventional light-frame construction and are located in areas with a basic wind speed from 80 through 110 miles per hour (mph) (129 km/h through 177 km/h).

**EXCEPTION:** Detached carports and garages not exceeding 600 square feet (55.7 m<sup>2</sup>) and accessory to Group R, Division 3 Occupancies need only comply with the roof-member-to-wall-tie requirements of Section 2365.5.8.

**2365.3 Definitions.** For the purpose of this chapter, certain terms are defined as follows:

**CORROSION RESISTANT** or **NONCORROSIVE** is material having a corrosion resistance equal to or greater than a hot-dipped galvanized coating of 1.5 ounces of zinc per square foot (4 g/m<sup>2</sup>) of surface area.

**2365.4 General.** The requirements of Section 2326 are applicable except as specifically modified by this chapter. Other methods may be used, provided a satisfactory design is submitted showing compliance with the provisions of Section 1611 and other applicable portions of this code.

In addition to the other provisions of this chapter, foundations for buildings in areas subject to wave action or tidal surge shall be designed in accordance with approved national standards.

When an element is required to be corrosion resistant or noncorrosive, all of its parts, such as screws, nails, wire, dowels, bolts, nuts, washers, shims, anchors, ties and attachments, shall also be corrosion resistant or noncorrosive.

#### **2365.5 Complete Load Path and Uplift Ties.**

**2365.5.1 General.** Blocking, bridging, straps, approved framing anchors or mechanical fasteners shall be installed to provide continuous ties from the roof to the foundation system. (See Figure A-23-1.)

Tie straps shall be 1<sup>1</sup>/<sub>8</sub>-inch (28.6 mm) by 0.036-inch (0.91 mm) (No. 20 gage) sheet steel and shall be corrosion resistant as herein specified. All metal connectors and fasteners used in exposed locations or in areas otherwise subject to corrosion shall be of corrosion-resistant or noncorrosive material.

**2365.5.2 Walls-to-foundation tie.** Exterior walls shall be tied to a continuous foundation, or an elevated foundation system in accordance with Section 2365.10.

**2365.5.3 Sills and foundation tie.** Foundation plates resting on concrete or masonry foundations shall be bolted to the foundation with not less than 1/2-inch-diameter (13 mm) anchor bolts with 7-inch-minimum (178 mm) embedment into the foundation. In areas where the basic wind speed is 90 mph (145 km/h) or greater, the maximum spacing of anchor bolts shall be 4 feet (1219 mm) on center. Structures located where the basic wind speed is less than 90 mph (145 km/h) may have anchor bolts spaced not more than 6 feet (1829 mm) on center.

**2365.5.4 Floor-to-foundation tie.** The lowest-level exterior wall studs shall be connected to the foundation sill plate or an approved elevated foundation system with bent tie straps spaced not more than 48 inches (1219 mm) on center. Tie straps shall be nailed and installed in accordance with Table A-23-B and Figure A-23-1.

**2365.5.5 Wall framing details.** The spacing of 2-inch by 4-inch studs (51 mm by 102 mm) in exterior walls shall not exceed 16 inches (406 mm) on center for areas with a basic wind speed of 90 mph (145 km/h) or greater.

Mechanical fasteners complying with this chapter shall be installed as required to connect studs to the sole plates, foundation sill plate and top plates of the wall.

Interior main cross-stud partitions shall be installed approximately perpendicular to the exterior wall when the length of the structure exceeds the width. The maximum distance between these partitions shall not exceed the width of the structure. Interior main cross-stud partition walls shall be securely fastened to exterior walls at the point of intersection with fasteners as required by Table 23-I-Q. The main cross-stud partitions shall be covered on both sides by materials as described in Section 2365.5.6.

**2365.5.6 Wall sheathing.** All exterior walls and required interior main cross-stud partitions shall be sheathed in accordance with Table A-23-A. The total width of sheathed wall elements shall not be less than 50 percent of the exterior wall length or 60 percent of the width of the building for required interior main cross-stud partitions. The exterior wall sheathing or covering shall extend from the foundation sill plate or girder to the top plates at the roof level and shall be adequately attached thereto.

A sheathed wall element not less than 4 feet (1219 mm) in width shall be installed at each corner or as near thereto as possible. There shall not be less than one 4-foot (1219 mm) sheathed wall element for every 20 feet (6096 mm) or fraction thereof of wall length. The height-to-length ratio of required sheathed wall elements shall not exceed 3 for wood structural panel or particleboard and  $1\frac{1}{2}$  (38 mm) for other sheathing materials listed in Table A-23-A.

**2365.5.7 Floor-to-floor tie.** Upper-level exterior wall studs shall be aligned and connected to the wall studs below with a tie strap as required by Table A-23-B.

**2365.5.8 Roof-members-to-wall tie.** Tie straps shall be provided from the side of the roof-framing member to the exterior studs, posts or other supporting members below the roof. The wall studs to which the roof-framing members are tied shall be aligned with the roof-framing member and be connected in accordance with Table A-23-B.

The eave overhang shall not exceed 3 feet (914 mm) unless an analysis is provided showing that the required resistance is provided to prevent uplift.

Where openings exceed 6 feet (1829 mm) in width, the required tie straps shall be doubled at each edge of the opening and connected to a doubled full-height wall stud. When openings exceed 12 feet (3658 mm) in width, ties designed to prevent uplift shall be provided.

**EXCEPTION:** The opening width may be increased to 16 feet (4877 mm) for garages and carports accessory to Group R, Division 3 Occupancies when constructed in accordance with the following:

1. Approved column bases shall be a minimum  $\frac{3}{16}$ -inch (4.8 mm) steel plate embedded not less than 8 inches (203 mm) into the concrete footing and connected to a minimum 4-inch by 4-inch (102 mm by 102 mm) wood post with two  $\frac{5}{8}$ -inch-diameter (15.9 mm) through bolts.
2. Beams over openings shall be connected to minimum 4-inch by 4-inch (102 mm by 102 mm) wood posts below with an approved  $\frac{3}{16}$ -inch (4.8 mm) steel post cap with two  $\frac{3}{8}$ -inch-diameter (15.9 mm) through bolts to the posts and to the beams.

**2365.5.9 Ridge ties.** Opposing rafters shall be aligned at the ridge and be connected at the rafters with a tie strap in accordance with Table A-23-C.

**2365.6 Masonry Veneer.** Anchor ties shall be spaced so as to support not more than  $1\frac{1}{3}$  square feet (860 mm<sup>2</sup>) of wall area but not more than 12 inches (305 mm) on center vertically. The materials and connection details shall comply with Chapter 14.

**2365.7 Roof Sheathing.** Solid roof sheathing shall be applied and shall consist of a minimum 1-inch-thick (25 mm) nominal lumber applied diagonally or a minimum  $1\frac{5}{32}$ -inch-thick

(11.9 mm) wood structural panel or particleboard or other approved sheathing applied with the long dimension perpendicular to supporting rafters. Sheathing shall be nailed to roof framing in an approved manner. The end joints of wood structural panels or particleboard shall be staggered and shall occur over blocking, rafters or other supports.

**2365.8 Gable-end Walls.** The roof overhang at gabled ends shall not exceed 2 feet (610 mm) unless an analysis showing that the required resistance to prevent uplift is provided.

Gable-end wall studs shall be continuous between points of lateral support which are perpendicular to the plane of the wall.

Gable-end wall studs shall be attached with approved mechanical fasteners at the top and bottom.

**2365.9 Roof Covering.** Roof coverings shall be approved and shall be installed and fastened in accordance with Chapter 15 and with the manufacturer's instructions. In areas with basic wind speeds of 90 mph (145 km/h) or greater strip asphalt shingles shall be fastened with a minimum of six fasteners and hand sealed.

**2365.10 Elevated Foundation.**

**2365.10.1 General.** When approved, elevated foundations supporting not more than one story and meeting the provisions of this section may be used. A foundation investigation may be required by the building official.

**2365.10.2 Material.** All exposed wood-framing members shall be treated wood. All metal connectors and fasteners used in exposed locations shall be corrosion-resistant or noncorrosive steel.

**2365.10.3 Wood piles.** The spacing of wood piles shall not exceed 8 feet (2438 mm) on center. Square piles shall not be less than 10 inches (254 mm) and tapered piles shall have a tip of not less than 8 inches (203 mm). Ten-inch-square (64 516 mm<sup>2</sup>) piles shall have a minimum embedment length of 10 feet (3048 mm) and shall project not more than 8 feet (2438 mm) above undisturbed ground surface. Eight-inch (203 mm) taper piles shall have a minimum embedment length of 14 feet (4267 mm) and shall project not more than 7 feet (2134 mm) above undisturbed ground surface.

**2365.10.4 Girders.** Floor girders shall be solid sawn timber, built-up 2-inch-thick (51 mm) lumber or trusses. Splices shall occur over wood piles. The floor girders shall span in the direction parallel to the potential floodwater and wave action.

**2365.10.5 Connections.** Wood piles may be notched to provide a shelf for supporting the floor girders. The total notching shall not exceed 50 percent of the pile cross section. Approved bolted connections with 1/4-inch (6.4 mm) corrosion-resistant or noncorrosive steel plates and 3/4-inch-diameter (19 mm) bolts shall be provided. Each end of the girder shall be connected to the piles using a minimum of two 3/4-inch-diameter (19 mm) bolts.

**TABLE A-23-A—WALL SHEATHING AT EXTERIOR WALLS AND INTERIOR MAIN CROSS-STUD PARTITIONS<sup>1</sup>**

BASIC WIND SPEED (mph) × 1.61 for km/h	STORIES	LEVEL <sup>2</sup>	EXPOSURE		
			B	C	D
80	1		A	A	B
	2	2 1	A C	A D	B D
	3	3 2 1	A C C	A D D	B D E
90	1		A	B	B
	2	2 1	A C	B D	B D
	3	3 2 1	A C D	B D E	Not permitted
100	1		A	C	C
	2	2 1	A C	C D	C E
	3	3 2 1	A C D	Not permitted	Not permitted
110	1		B	C	C
	2	2 1	B D	C E	C E

<sup>1</sup>Sheathing types; exterior walls with sheathing at one face, interior main cross-stud partitions with sheathing at each face. The values for sheathing are listed in order of increased capacity. Sheathing with a capacity greater than required may be substituted for the sheathing listed. Particleboard sheathing in accordance with Table 23-I-N-2 may be substituted for sheathing Types A and B.

- A. One-half-inch (12.7 mm) gypsum board or gypsum sheathing with 5d cooler nails at 7 inches (178 mm) or 3/8-inch (9.5 mm) gypsum lath and 1/2-inch (13 mm) plaster.
- B. One-half-inch (12.7 mm) gypsum board or gypsum sheathing with 5d cooler nails at 4 inches (102 mm).
- C. Expanded metal lath and 7/8-inch (22 mm) portland cement plaster.
- D. Three-eighths-inch (9.5 mm) wood structural panel or particleboard sheathing with 8d nails at 6 inches (153 mm) all edges and 12 inches (305 mm) intermediate.
- E. Three-eighths-inch (9.5 mm) plywood or particleboard sheathing with 8d nails at 4 inches (102 mm) all edges and 12 inches (305 mm) intermediate.

The application of these sheathing materials shall comply with Section 2513.5 and Table 25-1 for Types A, B and C, and Section 2314.1 and Table 23-I-K-1 or 23-I-K-2 for Types D and E. All panel edges of Types D and E shall be backed with 2-inch (51 mm) nominal or wider framing.

<sup>2</sup>Level refers to the space between the upper surface of any floor and upper surface of floor next above. The topmost level shall be the space between upper surface of the topmost floor and the ceiling or roof above. Wall sheathing at useable or unused under-floor space shall be provided as required for the level directly above.

**TABLE A-23-B—ROOF AND FLOOR ANCHORAGE AT EXTERIOR WALLS**

BASIC WIND SPEED (mph) × 1.61 for km/h	LOCATION <sup>1</sup>	NUMBER OF NAILS <sup>2</sup>		
		Exposure		
		B	C	D
80	roof to wall	6-8d	8-8d	8-10d
	floor to floor	—	4-10d	6-10d
	floor to foundation	—	4-10d	4-10d
90	roof to wall	8-8d	8-10d	10-10d
	floor to floor	—	6-10d	8-10d
	floor to foundation	—	4-10d	6-10d
100	roof to wall	8-10d	10-10d	12-10d
	floor to floor	6-10d	8-10d	10-10d
	floor to foundation	4-10d	6-10d	8-10d
110	roof to wall	10-10d	12-10d	12-10d
	floor to floor	8-10d	10-10d	10-10d
	floor to foundation	6-10d	8-10d	8-10d

<sup>1</sup>For floor-to-foundation anchorage, see Section 2365.5.4.

<sup>2</sup>Number of common nails listed is total required for each tie strap. The tie straps shall be spaced at 48 inches (1219 mm) on center along the length of the wall. The number of nails on each side of the roof or floor plate joints shall be equal. Nails shall be spaced to avoid splitting of the wood. See Figure A-23-1 for illustration of these tie straps.

**TABLE A-23-C—RIDGE TIE-STRAP NAILING<sup>1</sup>**

BASIC WIND SPEED (mph) × 1.61 for km/h	NUMBER OF NAILS <sup>1</sup>		
	Exposure		
	B	C	D
80	6-10d	8-10d	10-10d
90	8-10d	10-10d	12-10d
100	10-10d	12-10d	14-10d
110	12-10d	14-10d	16-10d

<sup>1</sup>Number of common nails listed is total required for each tie strap. The tie straps shall be spaced at 48 inches (1219 mm) on center along the length of the roof. The number of nails on each side of the rafter/ridge joint shall be equal. Nails shall be spaced to avoid splitting of the wood. See Figure A-23-1 for illustration of these tie straps.

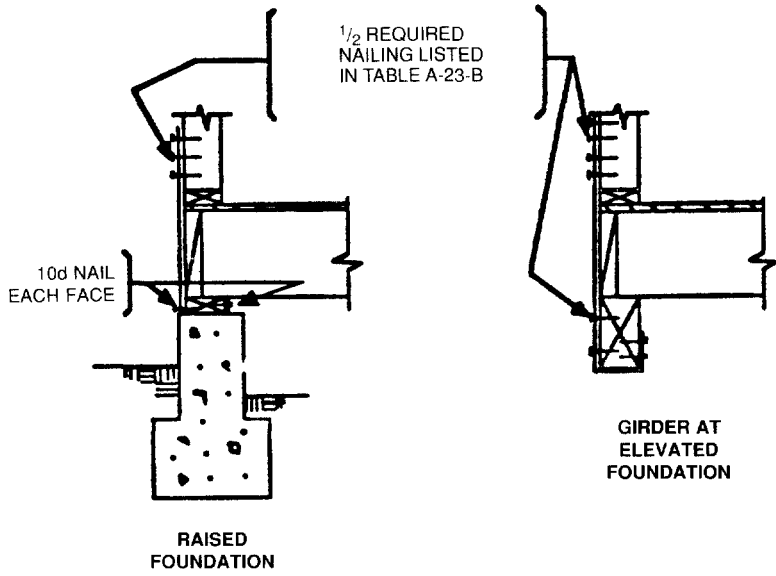

FIGURE A-23-1—COMPLETE LOAD PATH DETAILS

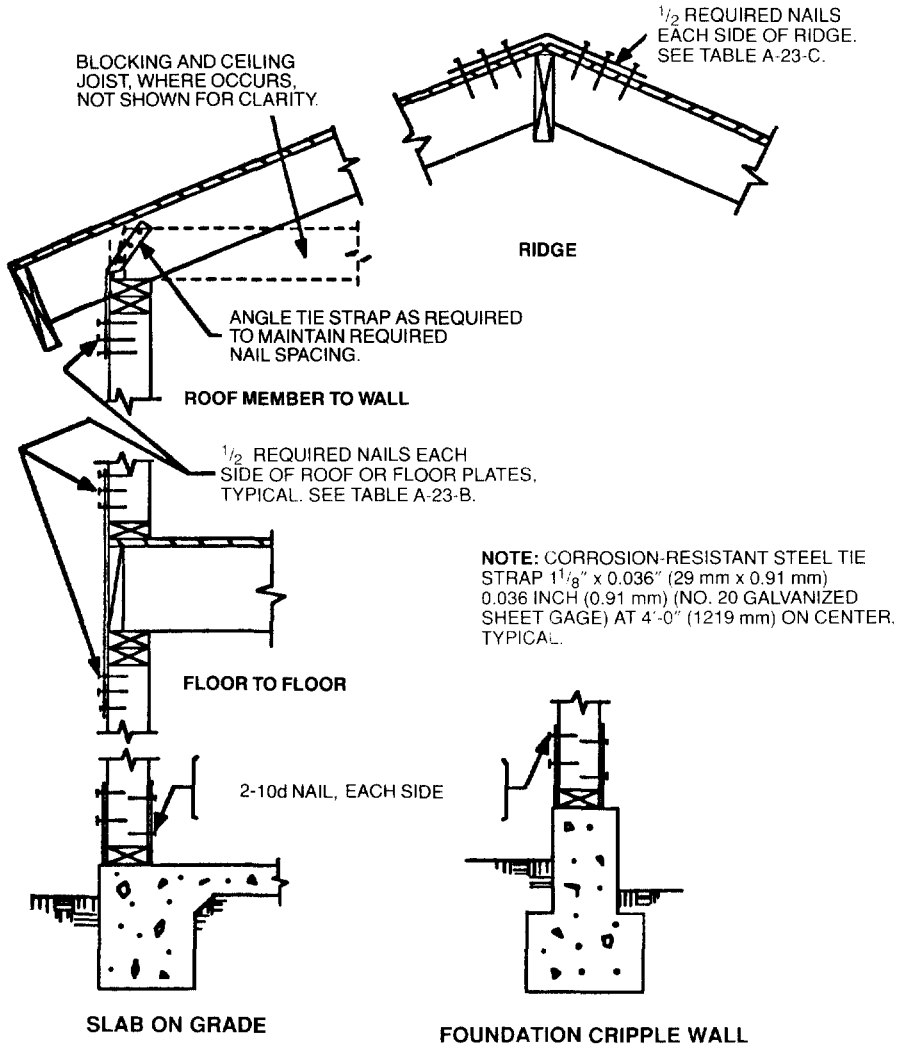

FIGURE A-23-1—COMPLETE LOAD PATH DETAILS—(Continued)

Appendix Chapters 30 through 34 are printed in Volume 1 of the *Uniform Building Code*